

Prime: 50 Hz



Picture shown may not reflect actual configuration.

FEATURES AND BENEFITS

CAT[®] DIESEL ENGINES

The four-cycle Cat diesel engine combines consistent performance with excellent fuel economy and transient response that meets ISO 8528-5. The engines feature a reliable, rugged, and durable design that has been field proven in thousands of applications worldwide in emergency standby installations.

CAT NOISE ENCLOSURE

The Genset is approved as per CPCB India Regulations. The Noise Enclosures are designed for easy access of all engine parts, and lube oil fumes disposal. The enclosures are made of Non-igniting, self-extinguishing mineral wool with resin bonded, used for noise and thermal insulation.

COOLING SYSTEM

The cooling system has been designed and tested to ensure proper generator set cooling, and includes the radiator, fan, belts, and all guarding installed as standard. Contact your Cat dealer for specific ambient and altitude capabilities.

GENERATORS

The generators used on Cat packages have been designed and tested to work with the Cat engine. The generators are built with robust Class H insulation and provide industry-leading motor starting capability and altitude capabilities.

CONTROL PANELS

The TCP 1000 is a compact Auto Mains (Utility) Failure Control Module that has been developed to provide an outstanding range of features. Monitoring engine speed, oil pressure, coolant temperature, frequency, voltage, current and power, the modules will give comprehensive engine and alternator protection.

Engine Model	Cat [®] C15 In-line 6, 4-cycle diesel
Bore x Stroke	137 mm x 171 mm (5.4 in x 6.8 in)
Displacement	15.2L (928 in ³)
Compression Ratio	17:1
Aspiration	Air-to-Air Aftercooled
Fuel Injection System	MEUI
Governor	Electronic ADEM [™] A4
Emission Certifications	India CPCB/ MoEF Standards

GENERATOR SET SPECIFICATIONS

Alternator Design	Brushless Single Bearing, 4 Pole
Stator	2/3 Pitch
No. of Leads	06
Available Voltage Option	415V
Frequency	50 Hz
Alternator Voltage	24V
Alternator Insulation and IP	Class H; IP23
Standard Temperature Rise	125°C
Available Excitation Options	Self-Excited
Voltage Regulation	±1%
Voltage Regulator	R150M

STANDARD and OPTIONAL EQUIPMENT

Air Inlet System	Dual element cannister type air cleaner Service indicator
Control Panels	TCP 1000 controller Emergency stop push button Product link generation - 444 Product link generation - 601 and 641 (Optional)
Cooling System	Radiator fan and belt drive Fan and belt guard Coolant drain line with valve Coolant level sensor Cat extended life coolant
Exhaust System	Dry exhaust manifold Flanged faced outlets Exhaust mufflers Stainless steel exhaust flex fittings Flanges
Fuel System	Primary and secondary fuel filters Fuel priming pump Flexible fuel lines Engine fuel transfer pump Integrated fuel cooler Enclosure integrated fuel tank
Generators and Generator Attachments	Self excited Class H insulation Class H temperature rise Random wound R150M voltage regulator Power terminal strip connections IP 23 protection
Governing System	Cat electronic governor (ADEM™ A4)
Lube System	Lubricating oil and filter Oil drain line with valves Fumes disposal Gear type lube oil pump Lube oil level indicator (dipstick)
Mounting	Anti-vibration mounts
Starting/Charging System	24 volt starting motor Batteries with rack and cables 45 amp charging alternator
General	SAE standard rotation Flywheel – SAE No.14 Flywheel housing – SAE No. 0.5 Paint – Caterpillar Yellow (except rails and radiators gloss black)

Prime: 50 Hz; 415V



Picture shown may not reflect actual configuration.

Engine Model	Cat® C15 In-line 6, 4-cycle diesel
Bore x Stroke	137 mm x 171 mm (5.4 in x 6.8 in)
Displacement	15.2L (928 in³)
Compression Ratio	17:1
Aspiration	Air-to-Air Aftercooled
Fuel Injection System	MEUI
Governor	Electronic ADEM™ A4

Model	Prime	Emission Strategy
C15	500 kVA, 400 kW	India CPCB/ MoEF Standards

PACKAGE PERFORMANCE

Performance	Prime
Frequency	50 Hz
Genset power rating with fan @ 0.8 power factor	500 kVA
Engine power rating	591 BHP
Fuelling strategy	India CPCB/ MoEF Standards
Performance number	EM0430
Fuel Consumption	
100% load with fan, L/hr (gal/hr)	106.6 (28.1)
75% load with fan, L/hr (gal/hr)	84.0 (22.1)
50% load with fan, L/hr (gal/hr)	59.9 (15.8)
25% load with fan, L/hr (gal/hr)	33.9 (8.9)
Cooling System ¹	
Radiator air flow restriction (system), kPa (in. Water)	0.12 (0.48)
Radiator air flow, m³/min (cfm)	660 (23308)
Total cooling system coolant capacity, L (gal)	70±2 (18.5±0.5)
Inlet Air	
Combustion air inlet flow rate, m³/min (cfm)	25.5 (899.7)
Max. allowable combustion air inlet temp, °C (°F)	48 (118)
Exhaust System	
Exhaust stack gas temperature, °C (°F)	471.2 (880.1)
Exhaust gas flow rate, m³/min (cfm)	91.4 (3227)
Exhaust system backpressure (maximum allowable), kPa (in. water)	10.0 (40.0)
Heat Rejection	
Heat rejection to jacket water, kW (Btu/min)	153 (8681)
Heat rejection to exhaust (total), kW (Btu/min)	400 (22769)
Heat rejection to atmosphere from engine, kW (Btu/min)	59 (3366)
Heat rejection to atmosphere from generator, kW (Btu/min)	23 (1314)
Lube System	
Sump refill with filter	62.0 (16.3)
Alternator ²	
Voltage, V	415
Motor starting capability @ 30% voltage dip, skVA	800
Current, A	695.6
Frame Size	LSAP47C
Excitation	Self-excited
Temperature Rise, °C	125

WEIGHTS and DIMENSIONS

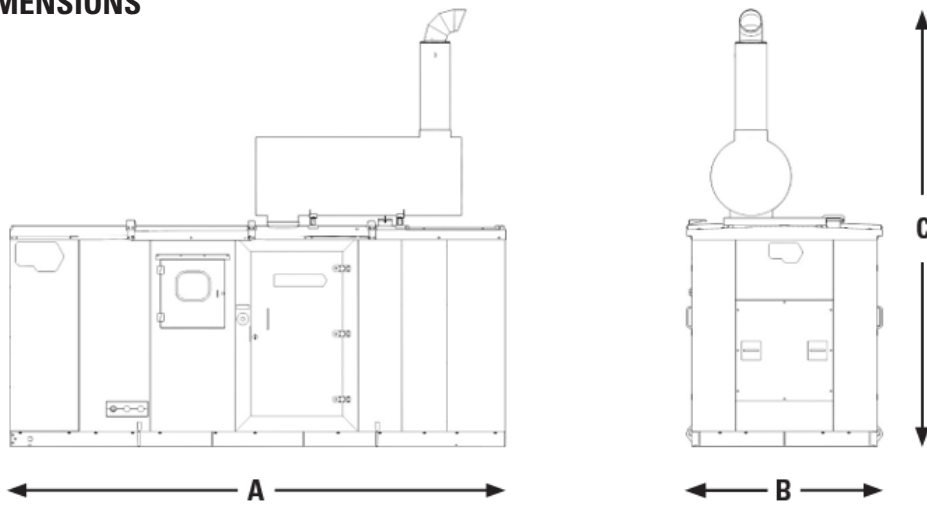

Genset Model	Length "A" mm (in)	Width "B" mm (in)	Height "C" mm (in)	Generator Set Weight kg (lb)
500 kVA, 400 ekW	5,050 (199)	1,800 (71)	2,200 (87)	5,350 (11,795)

***Note:** For reference only – do not use for dealer for installation design. Please contact your local exact weights and dimensions.

DEFINITIONS AND CONDITIONS

- ¹ For ambient and altitude capabilities consult your Cat dealer. Air flow restriction (system) is added to the existing restriction from the factory.
- ² Alternator temperature rise is based on a 40°C (104°F) ambient per NEMA MG1-32

APPLICABLE CODES AND STANDARDS

ISO 3046, ISO 8528, IEC60034-1, IS4722

Prime: Output available with varying load for an unlimited time. Prime power in accordance with ISO 8528. 10% overload power in accordance with ISO 3046.

Ratings: Ratings are based on SAE J1349 standard conditions. These ratings also apply at ISO 3046 standard conditions.

Fuel Rates: Fuel Consumption reported in accordance as per the ISO 3046-1 standard.

Additional ratings may be available for specific customer requirements, contact your Cat representative for details.

LET'S DO THE WORK.™

www.cat.com/electricpower
©2023 Caterpillar
All rights reserved.

Materials and specifications are subject to change without notice. The International System of Units (SI) is used in this publication. CAT, CATERPILLAR, LET'S DO THE WORK, their respective logos, "Caterpillar Corporate Yellow", the "Power Edge" and Cat "Modern Hex" trade dress as well as corporate and product identity used herein, are trademarks of Caterpillar and may not be used without permission.