

Cat® C32

Diesel Generator Sets



Image shown may not reflect actual configuration

Bore – mm (in)	145 (5.7)
Stroke – mm (in)	162 (6.4)
Displacement – L (in ³)	32 (1952.76)
Compression Ratio	15.0:1
Aspiration	TA
Fuel System	EUI
Governor Type	ADEM™ A4

Standby 50 Hz kVA (ekW)	Mission Critical 50 Hz kVA (ekW)	Prime 50 Hz kVA (ekW)	Continuous 50 Hz kVA (ekW)	Emissions Performance
1100 (880)	1100 (880)	1000 (800)	910 (728)	Optimized for Low Fuel Consumption or Low Emissions
1250 (1000)	1250 (1000)	1100 (880)	—	Optimized for Low Fuel Consumption

Standard Features

Cat® Diesel Engine

- Designed and optimized for low emissions or low fuel consumption
- Reliable and consistent performance proven in thousands of applications worldwide

Generator Set Package

- Accepts 100% block load in one step and meets the NFPA 110 loading requirements
- Conforms to ISO 8528-5 G3 load acceptance requirements.
- Reliability is verified through prototype testing, which includes torsional vibration, fuel consumption, oil consumption, transient performance, and endurance testing

Alternators

- Superior motor starting capability minimizes the need for oversizing the generator
- Designed to match the performance and output characteristics of Cat diesel engines

Cooling System

- Cooling systems available to operate in ambient temperatures up to 50°C (122°F)
- Tested to ensure proper generator set cooling

EMCP 4 Control Panels

- User-friendly interface and navigation
- Scalable system to meet a wide range of installation requirements
- Expansion modules and site specific programming for specific customer requirements

Warranty

- 24 months/1000-hour warranty for standby and mission critical ratings
- 12 months/unlimited hour warranty for prime and continuous ratings
- Extended service protection is available to provide extended coverage options

Worldwide Product Support

- Cat dealers have over 1,800 dealer branch stores operating in 200 countries
- Your local Cat dealer provides extensive post-sale support, including maintenance and repair agreements

Financing

- Caterpillar offers an array of financial products to help you succeed through financial service excellence
- Options include loans, finance lease, operating lease, working capital, and revolving line of credit
- Contact your local Cat dealer for availability in your region

Optional Equipment

Engine

Air Cleaner

- Single element
- Dual element
- Heavy duty

Muffler

- Industrial grade (15 dB)

Starting

- Standard batteries
- Oversized batteries
- Standard electric starter
- Dual electric starter
- Jacket water heater

Alternator

Output voltage

- 400V
- 415V

Temperature Rise (over 40°C ambient)

- 150°C
- 125°C/130°C
- 105°C
- 80°C

Winding type

- Random wound
- Form wound

Excitation

- Self excited
- Internal excitation (IE)
- Permanent magnet (PM)

Attachments

- Anti-condensation heater
- Stator and bearing temperature monitoring and protection

Power Termination

Type

- Bus bar
- Circuit breaker
- 1600A 2000A
- 2500A 3200A
- 4000A 3-pole
- UL IEC
- Manually operated
- Electrically operated

Trip Unit

- LSI LSI-G
- LSIG-P

Control System

Controller

- EMCP 4.2
- EMCP 4.3
- EMCP 4.4

Attachments

- Local annunciator module
- Remote annunciator module
- Remote monitoring software

Charging

- Battery charger – 10A

Vibration Isolators

- Rubber
- Spring

Extended Service Options

Terms

- 2 year (prime)
- 3 year
- 5 year
- 10 year

Coverage

- Silver
- Gold
- Platinum
- Platinum Plus

Ancillary Equipment

- Automatic transfer switch (ATS)
- Uninterruptible power supply (UPS)
- Paralleling switchgear
- Paralleling controls

Certifications

- EU Certification of Conformance (CE)
- EEC Declaration of Conformity

Note: Some options may not be available on all models. Certifications may not be available with all model configurations. Consult factory for availability.

Package Performance

1250 kVA Low Fuel Consumption

Performance	Standby		Mission Critical		Prime	
Frequency	50 Hz		50 Hz		50 Hz	
Gen set power rating with fan	1000 ekW		1000 ekW		880 ekW	
Gen set power rating with fan @ 0.8 power factor	1250 kVA		1250 kVA		1100 kVA	
Fueling strategy	Low Fuel		Low Fuel		Low Fuel	
Performance number	EM0679-00		EM0777-01		EM0745-01	
Fuel Consumption						
100% load with fan – L/hr (gal/hr)	252.3	(66.7)	252.3	(66.7)	220.7	(58.3)
75% load with fan – L/hr (gal/hr)	185.5	(49.0)	185.5	(49.0)	164.8	(43.5)
50% load with fan – L/hr (gal/hr)	128.4	(33.9)	128.4	(33.9)	116.1	(30.7)
25% load with fan – L/hr (gal/hr)	75.0	(19.8)	75.0	(19.8)	68.7	(18.1)
Cooling System						
Radiator air flow restriction (system) – kPa (in. water)	0.12	(0.48)	0.12	(0.48)	0.12	(0.48)
Radiator air flow – m ³ /min (cfm)	825	(29134)	825	(29134)	825	(29134)
Engine coolant capacity – L (gal)	55	(14.5)	55	(14.5)	55	(14.5)
Radiator coolant capacity – L (gal)	171	(45.0)	171	(45.0)	171	(45.0)
Total coolant capacity – L (gal)	226	(59.5)	226	(59.5)	226	(59.5)
Inlet Air						
Combustion air inlet flow rate – m ³ /min (cfm)	74.2	(2619.0)	74.2	(2619.0)	67.9	(2397.4)
Exhaust System						
Exhaust stack gas temperature – °C (°F)	464.6	(868.3)	464.6	(868.3)	440.6	(825.2)
Exhaust gas flow rate – m ³ /min (cfm)	192.9	(6812.8)	192.9	(6812.8)	170.3	(6012.6)
Exhaust system backpressure (maximum allowable) – kPa (in. water)	6.7	(27.0)	6.7	(27.0)	6.7	(27.0)
Heat Rejection						
Heat rejection to jacket water – kW (Btu/min)	340	(19353)	340	(19353)	308	(17537)
Heat rejection to exhaust (total) – kW (Btu/min)	871	(49555)	871	(49555)	752	(42748)
Heat rejection to aftercooler – kW (Btu/min)	241	(13691)	241	(13691)	196	(11173)
Heat rejection to atmosphere from engine – kW (Btu/min)	139	(7891)	139	(7891)	124	(7058)
Heat rejection from alternator – kW (Btu/min)	52	(2960)	52	(2960)	43	(2448)
Emissions (Nominal)						
NOx mg/Nm ³ (g/hp-h)	2928.1	(5.80)	2928.1	(5.80)	3185.5	(6.15)
CO mg/Nm ³ (g/hp-h)	229.6	(0.46)	229.6	(0.46)	209.4	(0.42)
HC mg/Nm ³ (g/hp-h)	5.7	(0.01)	5.7	(0.01)	5.6	(0.01)
PM mg/Nm ³ (g/hp-h)	11.9	(0.03)	11.9	(0.03)	11.3	(0.03)
Emissions (Potential Site Variation)						
NOx mg/Nm ³ (g/hp-h)	3543.0	(7.02)	3543.0	(7.02)	3854.5	(7.45)
CO mg/Nm ³ (g/hp-h)	429.3	(0.86)	429.3	(0.86)	391.6	(0.75)
HC mg/Nm ³ (g/hp-h)	10.7	(0.02)	10.7	(0.02)	10.5	(0.02)
PM mg/Nm ³ (g/hp-h)	23.2	(0.05)	23.2	(0.05)	22.1	(0.05)

Package Performance

1100 kVA Low Fuel Consumption

Performance	Standby	Mission Critical	Prime	Continuous
Frequency	50 Hz	50 Hz	50 Hz	60 Hz
Gen set power rating with fan	880 ekW	880 ekW	800 ekW	728 ekW
Gen set power rating with fan @ 0.8 power factor	1100 KVA	1100 kVA	1000 kVA	910 kVA
Fueling strategy	Low Fuel	Low Fuel	Low Fuel	Low Fuel
Performance number	DM9951-02	EM0447-01	DM9952-05	DM9953-01
Fuel Consumption				
100% load with fan – L/hr (gal/hr)	226.4 (59.8)	226.4 (59.8)	206.7 (54.6)	189.5 (50.1)
75% load with fan – L/hr (gal/hr)	170.3 (45.0)	170.3 (45.0)	155.5 (41.1)	142.8 (37.7)
50% load with fan – L/hr (gal/hr)	117.4 (31.0)	117.4 (31.0)	108.5 (28.7)	100.4 (26.5)
25% load with fan – L/hr (gal/hr)	69.1 (18.3)	69.1 (18.3)	65.2 (17.2)	60.8 (16.1)
Cooling System				
Radiator air flow restriction (system) – kPa (in. water)	0.12 (0.48)	0.12 (0.48)	0.12 (0.48)	0.12 (0.48)
Radiator air flow – m ³ /min (cfm)	883 (31182)	883 (31182)	883 (31182)	883 (31182)
Engine coolant capacity – L (gal)	55 (14.5)	55 (14.5)	55 (14.5)	55 (14.5)
Radiator coolant capacity – L (gal)	171 (45.0)	171 (45.0)	171 (45.0)	171 (45.0)
Total coolant capacity – L (gal)	226 (59.5)	226 (59.5)	226 (59.5)	226 (59.5)
Inlet Air				
Combustion air inlet flow rate – m ³ /min (cfm)	66.0 (2332.0)	66.0 (2332.0)	60.3 (2128.2)	55.9 (1974.0)
Exhaust System				
Exhaust stack gas temperature – °C (°F)	508.7 (947.7)	508.7 (947.7)	509.3 (948.7)	503.4 (938.0)
Exhaust gas flow rate – m ³ /min (cfm)	180.1 (6359.7)	180.1 (6359.7)	165.0 (5824.8)	152.0 (5368.7)
Exhaust system backpressure (maximum allowable) – kPa (in. water)	6.7 (27.0)	6.7 (27.0)	6.7 (27.0)	6.7 (27.0)
Heat Rejection				
Heat rejection to jacket water – kW (Btu/min)	319 (18167)	319 (18167)	300 (17054)	281 (15996)
Heat rejection to exhaust (total) – kW (Btu/min)	818 (46518)	818 (46518)	757 (43047)	698 (39684)
Heat rejection to aftercooler – kW (Btu/min)	181 (10283)	181 (10283)	148 (8412)	125 (7133)
Heat rejection to atmosphere from engine – kW (Btu/min)	120 (6797)	120 (6797)	108 (6150)	102 (5819)
Heat rejection from alternator – kW (Btu/min)	49 (2789)	49 (2789)	43 (2448)	38 (2163)
Emissions (Nominal)				
NOx mg/Nm ³ (g/hp-h)	2966.9 (5.84)	2966.9 (5.84)	2967.7 (5.84)	2914.2 (5.76)
CO mg/Nm ³ (g/hp-h)	308.9 (0.61)	308.9 (0.61)	316.8 (0.62)	315.2 (0.63)
HC mg/Nm ³ (g/hp-h)	4.0 (0.01)	4.0 (0.01)	7.5 (0.02)	10.9 (0.03)
PM mg/Nm ³ (g/hp-h)	14.1 (0.03)	14.1 (0.03)	17.0 (0.04)	18.3 (0.04)
Emissions (Potential Site Variation)				
NOx mg/Nm ³ (g/hp-h)	3589.9 (7.07)	3589.9 (7.07)	3590.9 (7.07)	3526.2 (6.97)
CO mg/Nm ³ (g/hp-h)	577.6 (1.14)	577.6 (1.14)	592.4 (1.17)	589.4 (1.17)
HC mg/Nm ³ (g/hp-h)	7.5 (0.02)	7.5 (0.02)	14.1 (0.03)	20.5 (0.05)
PM mg/Nm ³ (g/hp-h)	27.5 (0.07)	27.5 (0.07)	33.1 (0.08)	35.6 (0.09)

Package Performance

1100 kVA Low Emissions

Performance	Standby	Mission Critical	Prime	Continuous
Frequency	50 Hz	50 Hz	50 Hz	60 Hz
Gen set power rating with fan	880 ekW	880 ekW	800 ekW	728 ekW
Gen set power rating with fan @ 0.8 power factor	1100 kVA	1100 kVA	1000 kVA	910 kVA
Fueling strategy	Low Emissions	Low Emissions	Low Emissions	Low Emissions
Performance number	DM9945-04	EM0448-00	DM9946-04	DM9947-03
Fuel Consumption				
100% load with fan – L/hr (gal/hr)	243.2 (64.2)	243.2 (64.2)	224.2 (59.2)	203.0 (53.6)
75% load with fan – L/hr (gal/hr)	184.1 (48.6)	184.1 (48.6)	168.1 (44.4)	154.9 (40.9)
50% load with fan – L/hr (gal/hr)	1260 (33.3)	1260 (33.3)	115.2 (30.4)	106.1 (28.0)
25% load with fan – L/hr (gal/hr)	70.9 (18.7)	70.9 (18.7)	65.9 (17.4)	61.5 (16.2)
Cooling System				
Radiator air flow restriction (system) – kPa (in. water)	0.12 (0.48)	0.12 (0.48)	0.12 (0.48)	0.12 (0.48)
Radiator air flow – m ³ /min (cfm)	883 (31182)	883 (31182)	883 (31182)	883 (31182)
Engine coolant capacity – L (gal)	55 (14.5)	55 (14.5)	55 (14.5)	55 (14.5)
Radiator coolant capacity – L (gal)	171 (45.0)	171 (45.0)	171 (45.0)	171 (45.0)
Total coolant capacity – L (gal)	226 (59.5)	226 (59.5)	226 (59.5)	226 (59.5)
Inlet Air				
Combustion air inlet flow rate – m ³ /min (cfm)	76.0 (2684.6)	76.0 (2684.6)	72.0 (2541.4)	65.4 (2311.0)
Exhaust System				
Exhaust stack gas temperature – °C (°F)	509.2 (948.6)	509.2 (948.6)	501.1 (934.0)	500.2 (932.4)
Exhaust gas flow rate – m ³ /min (cfm)	207.0 (7310.2)	207.0 (7310.2)	193.7 (6839.9)	176.6 (6236.9)
Exhaust system backpressure (maximum allowable) – kPa (in. water)	6.7 (27.0)	6.7 (27.0)	6.7 (27.0)	6.7 (27.0)
Heat Rejection				
Heat rejection to jacket water – kW (Btu/min)	312 (17723)	312 (17723)	288 (16392)	266 (15109)
Heat rejection to exhaust (total) – kW (Btu/min)	951 (54087)	951 (54087)	881 (50080)	801 (45572)
Heat rejection to aftercooler – kW (Btu/min)	253 (14386)	253 (14386)	223 (12680)	179 (10154)
Heat rejection to atmosphere from engine – kW (Btu/min)	107 (6077)	107 (6077)	107 (6081)	104 (5913)
Heat rejection from alternator – kW (Btu/min)	49 (2789)	49 (2789)	43 (2448)	38 (2163)
Emissions (Nominal)				
NOx mg/Nm ³ (g/hp-h)	1937.6 (4.11)	1937.6 (4.11)	1850.7 (3.95)	1861.1 (3.95)
CO mg/Nm ³ (g/hp-h)	100.5 (0.22)	100.5 (0.22)	77.2 (0.17)	100.0 (0.21)
HC mg/Nm ³ (g/hp-h)	11.4 (0.03)	11.4 (0.03)	15.1 (0.04)	16.8 (0.04)
PM mg/Nm ³ (g/hp-h)	11.6 (0.03)	11.6 (0.03)	9.8 (0.03)	10.6 (0.03)
Emissions (Potential Site Variation)				
NOx mg/Nm ³ (g/hp-h)	2344.4 (4.98)	2344.4 (4.98)	2239.3 (4.78)	2252.0 (4.78)
CO mg/Nm ³ (g/hp-h)	188.0 (0.41)	188.0 (0.41)	144.3 (0.31)	187.0 (0.40)
HC mg/Nm ³ (g/hp-h)	21.5 (0.05)	21.5 (0.05)	28.5 (0.07)	31.7 (0.08)
PM mg/Nm ³ (g/hp-h)	22.5 (0.06)	22.5 (0.06)	19.0 (0.05)	20.7 (0.05)

Weights and Dimensions

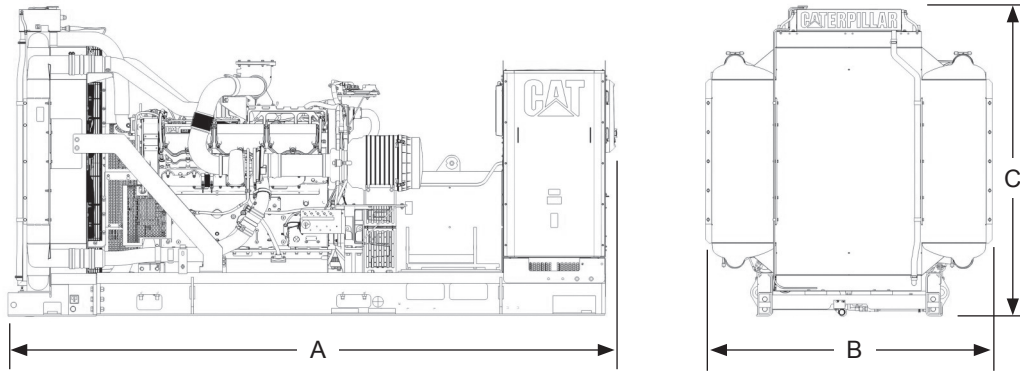

Standby 50 Hz kVA (ekW)	Mission Critical 50 Hz kVA (ekW)	Prime 50 Hz kVA (ekW)	Continuous 50 Hz kVA (ekW)	Dim "A" mm (in)	Dim "B" mm (in)	Dim "C" mm (in)	Dry Weight kg (lb)
1100 (880)	1100 (880)	1000 (800)	910 (728)	4270 (168.1)	2011 (79.2)	2174 (85.6)	6659 (14,680)
1250 (1000)	1250 (1000)	1100 (880)	—	4370 (172.0)	2011 (79.2)	2174 (85.6)	6899 (15,210)

Note: For reference only. Do not use for installation design. Contact your local Cat dealer for precise weights and dimensions.

Ratings Definitions

Standby

Output available with varying load for the duration of the interruption of the normal source power. Average power output is 70% of the standby power rating. Typical operation is 200 hours per year, with maximum expected usage of 500 hours per year.

Mission Critical

Output available with varying load for the duration of the interruption of the normal source power. Average power output is 85% of the mission critical power rating. Typical peak demand up to 100% of rated power for up to 5% of the operating time. Typical operation is 200 hours per year, with maximum expected usage of 500 hours per year.

Prime

Output available with varying load for an unlimited time. Average power output is 70% of the prime power rating. Typical peak demand is 100% of prime rated kW with 10% overload capability for emergency use for a maximum of 1 hour in 12. Overload operation cannot exceed 25 hours per year.

Continuous

Output available with non-varying load for an unlimited time. Average power output is 70-100% of the continuous power rating. Typical peak demand is 100% of continuous rated kW for 100% of the operating hours.

Applicable Codes and Standards

AS1359, CSA C22.2 No100-04, UL142, UL489, UL869, UL2200, NFPA37, NFPA70, NFPA99, NFPA110, IBC, IEC60034-1, ISO3046, ISO8528, NEMA MG1-22, NEMA MG1-33, 2014/35/EU, 2006/42/EC, 2014/30/EU.

Note: Codes may not be available in all model configurations. Please consult your local Cat dealer for availability.

Data Center Applications

Tier III/Tier IV compliant per Uptime Institute requirements. ANSI/TIA-942 compliant for Rated-1 through Rated-4 data centers.

Fuel Rates

Fuel rates are based on fuel oil of 35° API [16°C (60°F)] gravity having an LHV of 42,780 kJ/kg (18,390 Btu/lb) when used at 29°C (85°F) and weighing 838.9 g/liter (7.001 lbs/U.S. gal.)

www.cat.com/electricpower

©2017 Caterpillar
 All rights reserved.

Materials and specifications are subject to change without notice. The International System of Units (SI) is used in this publication.

CAT, CATERPILLAR, their respective logos, ADEM, "Caterpillar Yellow", the "Power Edge" trade dress as well as corporate and product identity used herein, are trademarks of Caterpillar and may not be used without permission.