



Cat[®] 785G

MINING TRUCK

FEATURES:

- **Performance** – The 785G 3512E HD engine gives you the choice of power ratings: 1,450 hp to match your current fleet performance or 1,600 hp for faster cycle times. Advanced Productivity Electronic Control Strategy for Transmission delivers a smoother ride, better acceleration and gear optimization.
- **Safety** – Standard Cat[®] Detect system, LED lighting, 600 mm (24 in) wide walkways, guarding of rotating components and hydraulic brake system with enhanced traction control system. Optional Working at Heights and Powered Access stairway.
- **Serviceability** – Modular HVAC system, modular radiator, improved ground level serviceability, oil sight glass, 1,000 hour hydraulic filter, and Tier 4 SCR system improves serviceability and reduces downtime.
- **Operator Environment** – New, quieter and larger, ergonomic deluxe cab. Electronic transmission controls and Cat comfort seats provides a smoother ride. Full size trainer door and improved head clearance on platform.
- **Operating Cost** – Improved 3512E HD engine meets U.S. EPA Tier 4 Final emission standards, and the features Cat Selective Catalytic Reduction (SCR) system that provides the least Total Fluid Consumption cost with greater reliability.
- **Tire Options** – With 36R51 tire option, particularly flat long haul high speed applications can take advantage of higher payload and higher TKPH.

Specifications

Engine

Engine Model	Cat 3512E HD	
Gross Power – SAE J1995:2014	1193 kW	1,600 hp
Bore	170 mm	6.7 in
Stroke	215 mm	8.5 in
Displacement	58.56 L	3,573 in ³

- Power rating conditions:
 - At 1,650 rpm rated speed based on SAE J1995:2014 standard air inlet conditions of 25° C (77° F) and 99 kPa (29.31 in Hg) dry barometric pressure.
 - Based on fuel of 35° API gravity (at 15.6° C or 60° F) having a LHV of 42 780 kJ/kg (18,390 Btu/lb) when used at 29° C (84.2° F).
- No engine derating required up to 2987 m (9800 ft) altitude per standard conditions.
- Meets U.S. EPA Tier 4 Final emissions standards.
- Selectable 1,450 hp configuration.

Weights – Approximate

Empty Operating Chassis Weight	84 668 kg	186,661 lb
Body Weight Range	21 275 kg- 30 623 kg	46,903 lb- 67,512 lb

- Chassis weight includes standard mandatory attachments, 33R51 tires, all operating fluid levels full and 100% fuel.
- Estimated weight of debris is not included in operating chassis weight.
- Body weight varies depending on body selection and configuration.

Operating Specifications

Gross Machine Operating Weight (GMW) (33R51 tires)	249 476 kg	550,000 lb
Gross Machine Operating Weight (GMW) (36R51 tires)	255 826 kg	564,000 lb
Nominal Payload Capacity (33.00R51 tires)*	132 tonnes	146 tons
Nominal Payload Capacity (36.00R51 tires)*	134 tonnes	148 tons

- GMW depends on tire selection. Consult your tire manufacturer for maximum loaded top speed.
- Refer to the Cat Mining Truck 10/10/20 Overload Policy (AEXQ0250) for maximum gross machine weight limitations.

*Includes standard liners and MSD II (Mine Specific Design) body.

Tires

Standard Tire	33.00R51 (E3 and E4)
Optional Tire	36.00R51 (Michelin and Bridgestone)

- Productive capabilities of the 785G truck are such that, under certain job conditions, TKPH (TMPH) capabilities could be exceeded and, therefore, limit production.
- Caterpillar recommends the customer evaluate all job conditions and consult the tire manufacturer for proper tire selection.



785G Mining Truck

Transmission

Forward 1	12.1 km/h	7.5 mph
Forward 2	16.3 km/h	10.2 mph
Forward 3	22.2 km/h	13.8 mph
Forward 4	29.9 km/h	18.6 mph
Forward 5	40.6 km/h	25.2 mph
Forward 6	54.8 km/h	34 mph
Reverse	11 km/h	6.8 mph
Total Final Drive Reduction Ratio	22.75:1	

- Maximum travel speeds with standard 33.00-R51 tires.

Suspension

Cylinder Stroke – Front	320 mm	12.6 in
Cylinder Stroke – Rear	165 mm	6.5 in

Body Hoists

Body Raise Time– High Idle	15.2 Seconds
Body Lower Time- Float High Idle	15.9 Seconds
Body Lower Time– Float Low Idle	16.2 Seconds
Body Power Down– High Idle	15.9 Seconds

- Twin, two-stage hydraulic cylinder mounted outside main frame; double-acting cylinders in second stage.
- Power raise in both stages; power down in second stage.
- Automatic body lower modulation reduces impact on frame.

Braking System

Brake Surface – Front	61 270 cm ²	9,487 in ²
Brake Surface –Rear	89 728 cm ²	13,908 in ²
Standards	ISO 3450:2011	

- Oil cooled four corner hydraulic actuated disc brakes.

Weight Distributions – Approximate

Front Axle – Empty	48%
Rear Axle – Empty	52%
Front Axle – Loaded (target)	33%
Rear Axle – Loaded (target)	67%

Body

Standard Dual Slope Weight	23 538 kg	51,892 lb
Standard Dual Slope Volume (SAE 2:1)	78 m ³	102 yd ³
Standard MSD Weight	21 188 kg	46,711 lb
Standard MSD Volume (SAE 2:1)	99 m ³	130 yds ³

- Body weight only. Does not include liners.
- Contact your local Cat dealer for site specific body recommendations.

Service Refill Capacities

Fuel Tank	1552 L	410 gal
DEF Tank	136 L	36 gal
Cooling System	379 L	100 gal
Engine Crankcase	204 L	54 gal
Differentials and Final Drives	527 L	139 gal
Steering Tank	110 L	29 gal
Steering System (includes tank)	170 L	45 gal
Brake/Hydraulic Tank	511 L	135 gal
Brake/Hoist System (includes tank)	606 L	160 gal
Torque Converter/Transmission System (includes sump)	175 L	46 gal

- Separate steering system and separate torque converter/transmission system prevents cross contamination.
- Contact your local Cat dealer for DEF infrastructure recommendations.

Steering

Steering Standards	ISO 5010:2007	
Turning Diameter – ISO 7457:1997 (33.00R51 tires)	29.8 m	97 ft 9 in
Machine Clearance Diameter – ISO 7457:1997 (33.00R51 tires)	33.2 m	108 ft 11 in
Steering Angle	36 degrees	

ROPS

- ROPS (Rollover Protective Structure) for cab offered by Caterpillar meets ISO 3471:2008 ROPS and ISO 13459:2012 criteria.
- FOPS (Falling Objects Protective Structure) meets ISO 3449:2005 and ISO 13459:2012 Level II criteria.

Sound

Cooling Fan Drive	Direct Drive	Optional Clutch
Operator Sound Level (ISO 6396:2008)	77 dB(A)	75 dB(A)
Machine Sound Level (ISO 6395:2008)	121 dB(A)	120 dB(A)

- Testing done per specified standard work cycle procedures and conditions with 50% HVAC blower fan speed. Optional clutch control fan measurement done at 70% of maximum engine cooling fan speed.
- Hearing protection may be needed when operating with an open operator station/cab (when not properly maintained or doors/windows open) for extended periods or in a noisy environment.

785G Mining Truck

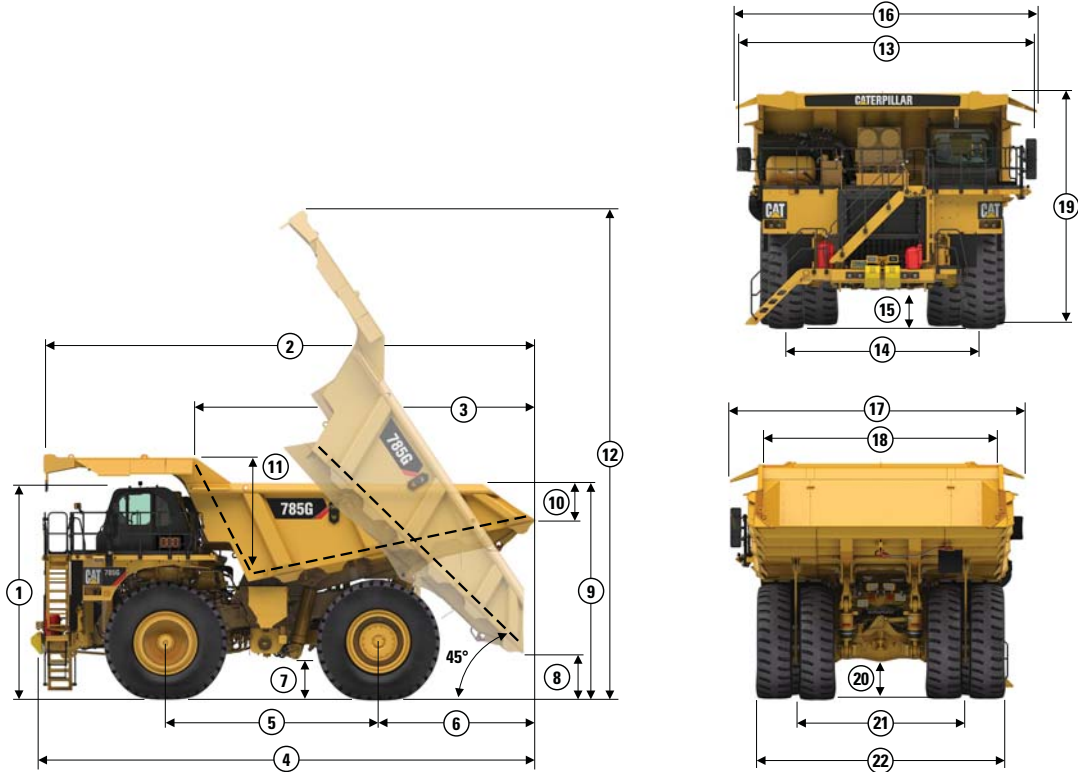

Dimensions (All dimensions are approximate. MSD II Body, 33R51 tires, unloaded machine.)

1 Height to Top of ROPS	5208 mm	17 ft 1 in	12 Overall Height – Body Raised	12 032 mm	39 ft 6 in
2 Overall Body Length	11 985 mm	39 ft 4 in	13 Operating Width	7535 mm	24 ft 9 in
3 Inside Body Length	8318 mm	27 ft 3 in	14 Centerline Front Tire Width	4850 mm	15 ft 11 in
4 Overall Length	11 957 mm	39 ft 3 in	15 Engine Guard Clearance	1038 mm	3 ft 5 in
5 Wheelbase	5180 mm	17 ft 0 in	16 Overall Canopy Width	7562 mm	24 ft 10 in
6 Rear Axle to Tail	3829 mm	12 ft 7 in	17 Outside Body Width	6714 mm	22 ft 0 in
7 Ground Clearance	1004 mm	3 ft 4 in	18 Inside Body Width	6010 mm	19 ft 9 in
8 Dump Clearance	1128 mm	3 ft 8 in	19 Front Canopy Height	6035 mm	19 ft 10 in
9 Loading Height – Empty	5299 mm	17 ft 5 in	20 Rear Axle Clearance	990 mm	3 ft 3 in
10 Rear Sidewall Height	874 mm	2 ft 10 in	21 Centerline Rear Dual Tire Width	4285 mm	14 ft 1 in
11 Inside Body Depth – Maximum	2790 mm	9 ft 2 in	22 Overall Tire Width	6277 mm	20 ft 7 in

STANDARD EQUIPMENT

POWER TRAIN

- 33R51 power train with standard rims
- Cat 3512E high displacement Tier 4 Final engine and aftertreatment
 - Automatic engine and DEF thermal management
 - Automatic low voltage idle management
 - Air cleaner with precleaner (two)
 - Turbocharging (four) with air-to-air aftercooler
 - Mechanical Electronic Unit Injector (MEUI™-A) fuel system
 - Automatic starter protection
 - Automatic ether starting aid
- Hydraulic braking system:
 - Automatic retarder control, adjustable
 - Oil-cooled, multi-disc (front and rear)
 - Service, retarding, parking, secondary
 - Anti roll back strategy
 - Engine over speed protection
 - Park brake integrated with gear selector
 - Brake release motor (towing)
 - Extended life brake disc material
- Transmission:
 - Six-speed, automatic power shift with Electronic Clutch Pressure Control (ECPC)
 - Advanced Productivity Electronic Control Strategy (APECS)
- Body-up reverse neutralizer
- Body-up shift inhibitor
- Downshift/reverse shift inhibitor
- Directional shift management
- Enhanced Traction Control System
- Programmable top gear
- Oil level sensor
- Neutral coast inhibitor
- Neutral start switch
- Lock-up torque converter
- Rear axle continuous lubrication/filtration

(Continued on next page)

785G Mining Truck

STANDARD EQUIPMENT (Continued)

ELECTRICAL

- Jump start/battery charge receptacle
- Ground accessible power control box
 - Ethernet VIMS™ port and VIMS™ lamp
 - Engine starter, transmission and battery lockouts
- Brushless alternator, 225 amp
- Alarm, backup
- 24V electrical system, low maintenance batteries (2) 93 amp-hour
- LED payload indicator lamps
- LED lighting system:
 - Backup and hazard lights
 - Curb lights, (one) RH side, (one) LH side
 - Turn signals (front and rear)
 - Engine compartment lights
 - Headlights with low-high beam selector
 - Ladder light and service deck lights
 - Stop/tail lights

OPERATOR ENVIRONMENT

- Unitized hydraulic powered HVAC with automatic temperature control
- Four point seat belt for operator seat
- Power windows
- Heated mirrors, right and left
- Heated and ventilated operator seat
- Operator and trainer air suspension seats

- Storage locations for operator gear
- Provision for customer accessory mounting
- Diagnostic connection port COM3 and Ethernet
- Dome courtesy light and map lights
- Fire suppression ready
- Delayed Engine Shutdown
- Integrated object detection system with touchscreen display
- Interactive touchscreen vehicle information display
 - Day/night mode
 - Action alarm
 - Quad gauge display
- Gauges and indicators panel:
 - Critical oil and coolant temperatures
 - Fuel and DEF level
 - Engine system, brake and transmission fault indicators
 - Speedometer, Tachometer
- Entertainment radio ready:
 - Speakers
 - Antenna (AM/FM/WB/satellite radio)
 - Radio mounting provisions and 12V power supply
- Retractable front visor
- 12V auxiliary power connection
- ROPS cab, insulated/sound suppressed

- Hoist, body control (electric)
- Stairway and walkway access, 600 mm (24 in)
- Steering wheel, tiltable, telescopic
- Windshield wiper, intermittent control
- Self-filling to windshield washer fluid from AC condensate

FLUIDS

- Extended Life Coolant, –35° C (–30° F)

TECHNOLOGY PRODUCTS

- Product Link™ Elite

OTHER STANDARD EQUIPMENT

- Turbine air starter with air tank, air horn and automatic lubrication system
- Auxiliary “buddy” dumping quick connect
- Auxiliary steering quick connect (towing)
- Hydraulic Filters, 1,000 hours
- Guards for rotating components
- Fast fill fuel and DEF remote fill system
- Secondary steering (automatic)
- Tie off points
- Tow hooks (front) and tow pin (rear)
- Vital Information Management System (VIMS)
- Auxiliary connection ‘user defined shutdown’
- Sight glasses for hydraulic oils
- S-O-S™ ports

OPTIONAL EQUIPMENT

POWER TRAIN

- Quick change rims
- 36R51 larger tire power train arrangement
- Prelube, engine
- Rear axle cooler
- Clutch control, variable speed cooling fan

BODY

- MSD volume: 99 m³ (130 yds³)
- MSD II body: 100 m³ (131 yd³)
- Dual slope body: 78 m³ (102 yd³)
- Body specific side wall and tail extensions
- Customizable body liner packages
- Body heat exhaust
- Rock ejectors

- Rear body lighting group
 - Directional signals
 - Stop/tail lights

ELECTRICAL

- Electronic Throttle Lock
- Digital Payload Display
- Auxiliary rear work lights, (one) RH side, (one) LH side
- No air – electric starter with 93-amp hour batteries (four), electric horn and automatic lubrication system

OTHER ATTACHMENTS

- Fire Suppression System – ANSUL® LVS
- Powered access stairway
- Fuel heater, fuel water separator

- Road Analysis Control (RAC)
- Cold weather start (block heater)
- Ground accessible fluid service center, hydraulic and coolant
- Bumper towing – center pin kit
- Communication Ar – Minestar™ radio
- Miscellaneous:
 - Fire extinguisher, portable
 - Hub odometer, kilometers
 - Wheel chocks
 - Gauge, brake wear indicator
 - Five piece crankcase guards
 - Working at heights protection

ANTIFREEZE

- Coolant, –50° C (–58° F)

For more complete information on Cat products, dealer services, and industry solutions, visit us on the web at www.cat.com

AEHQ7932 (08-2017)

© 2017 Caterpillar
All rights reserved

Materials and specifications are subject to change without notice. Featured machines in photos may include additional equipment. See your Cat dealer for available options.

CAT, CATERPILLAR, SAFETY.CAT.COM, their respective logos, “Caterpillar Yellow” and the “Power Edge” trade dress, as well as corporate and product identity used herein, are trademarks of Caterpillar and may not be used without permission.

