



Cat[®] TH3510D

AG HANDLER

FEATURES:

- **Engine Options** – Choose the right engine for you – two fuel efficient Cat[®] engines are available to suit a wide range of applications.
- **Transmission Options** – The Cat TH3510D features a 6 speed powershift transmission to give exceptional performance when towing trailers on the road.
- **Frame, Boom and Linkage** – Designed for durability. Easy to access greasing points mean a long, trouble free life for the machine. A Z-bar linkage with 150 degrees of coupler rotation delivers powerful breakout forces and fast cycle times.
- **Powerful Hydraulics** – A variable displacement piston pump matched to a high performance flow sharing valve makes multi functioning easy. The load sensing system means excellent fuel economy, as the pump only works when required.
- **Cab** – The cab is designed with a multi function joystick gives the operator a comfortable working environment. The unique “Operator Preferences” feature allows the machine to be tuned to suit individual operators. Options include a heated air suspension seat, large display screen with pre-loaded load charts, rear view camera, reversing sensors and air conditioning.

Specifications

Engine

	Standard	Optional
Model*	Cat C4.4 ACERT™	Cat C4.4 ACERT
Gross power	74.5 kW (100 hp/bhp)	96.5 kW (129 hp/bhp)
Max torque	410 N-m	514 N-m
Bore	105 mm	105 mm
Stroke	127 mm	127 mm
Displacement	4.4 L	4.4 L

*Meets EU Stage IIIA equivalent emission standards.

Weights

Operating Weight with Carriage and Forks* 9006 kg

*Represents machine configuration of 96.5 kW (129 hp/bhp) engine on standard 15.5/80-24 16 ply tires.

Operating Specifications

Rated Load Capacity	3500 kg
Maximum Lift Height	9.8 m
Capacity at Maximum Lift Height	770 kg
Maximum Forward Reach	6.6 m
Capacity at Maximum Forward Reach	500 kg
Outside Turning Radius over Tires	3.85 m
Outside Turning Radius over Forks	4.88 m

Service Refill Capacities

Fuel Tank	148 L	40 gal
Hydraulic Tank	120 L	31.7 gal

Brakes

Service Brakes	Oil immersed multi disc on both axles
Parking Brake	Mechanically actuated on front axle service brakes

Transmission*

Type	Four or six speed power shift
Forward	
1	5.7 km/h
2	8.6 km/h
3	11.2 km/h
4	16.6 km/h
5	25.3 km/h
6	40 km/h
Reverse	
1	5.7 km/h
2	11.2 km/h
3	25.3 km/h

*Travel speed is subject to machine configuration.



TH3510D Ag Handler

Electrical

Battery	1 × 12V 1,000 CCA Battery
Alternator Output	12V/150A

Hydraulic System

System Type	Load Sensing, Closed Center
Pump Type	Variable Flow, Axial Piston
Maximum Pump Capacity	140 L/min
System Pressure	260 bar
Auxiliary Hydraulic Pressure	245 bar
Auxiliary Hydraulic Flow	
Boom Head – Intermittent	95 L/min
Boom Head – Continuous	95 L/min
Machine Rear	80 L/min

Boom Performance

Boom Up	8 sec
Boom Down	6.5 sec
Tele Out	11 sec
Tele In	10.5 sec
Crowd Forward (Dump)	3 sec
Crowd Backward	3.5 sec
Combined	
Up and Out	24 sec
Down and In	12.8 sec

Axles

Front Axle	High bias, planetary reduction hubs with limited slip differential
Rear Axle	Open differential with planetary reduction hubs

Tires

Standard	Mitas 15.5/80-24 16 ply
Options	Michelin 15.5 R25 XHA Michelin 460/70 R24 XMCL Michelin 500/70 R24 XMCL Michelin 440/80 24 Power CL Michelin 400/80 24 Power CL Michelin 460/70 R24 Bibload Firestone Duraforce 13 × 24 Solid Tires

Performance

Drawbar Pull		
74.5 kW/100 hp Engine		68 kN
96.5 kW/129 hp Engine		90 kN
Boom Breakout Force		41 kN
Bucket Breakout Force		62 kN
Quick Coupler Rotation		152°
Noise Levels		
In Cab		74 dB(A)
External		106 dB(A)
Towable Mass		
Hydraulically Braked		12 000 kg

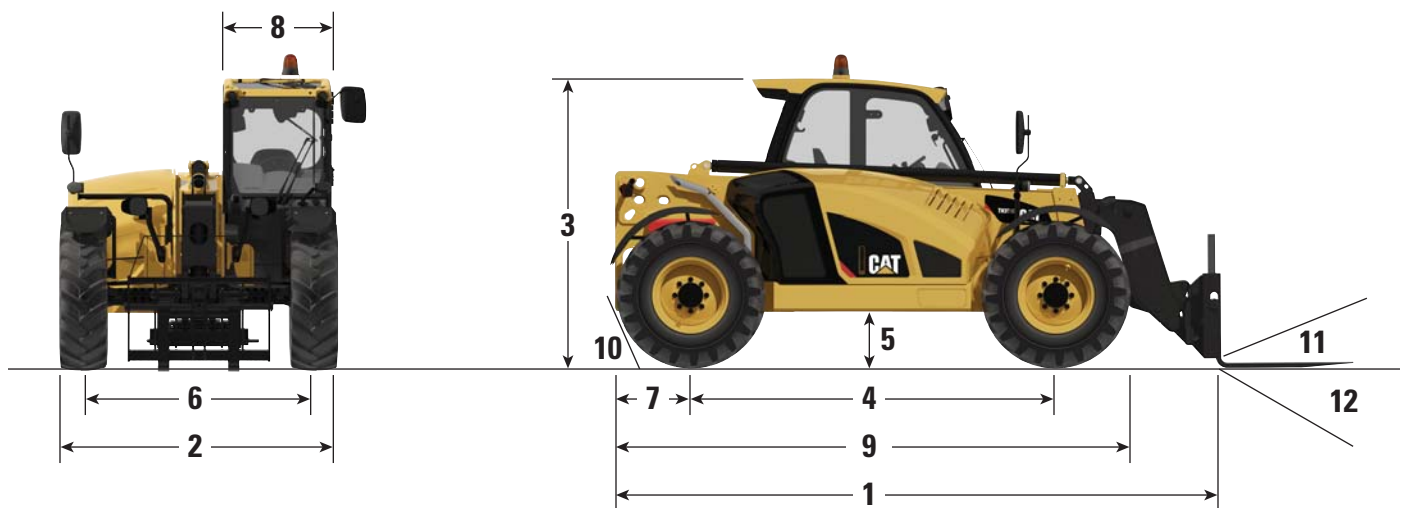

Dimensions (All dimensions are approximate.)

1 Overall Length to Front of Carriage	5300 mm	7 Overhang	1000 mm
2 Overall Width (standard tires)	2382 mm	8 Cab Width	900 mm
3 Overall Height (standard tires)*	2475 mm	9 Machine Length	5260 mm
4 Wheelbase	3165 mm	10 Departure Angle	60°
5 Ground Clearance	430 mm	11 Maximum Fork Crowd Angle	24°
6 Track	1988 mm	12 Maximum Fork Dump Angle	128°

*Add 200 mm for beacon.
Add 40 mm for top guard.

Load Chart and Dimensions

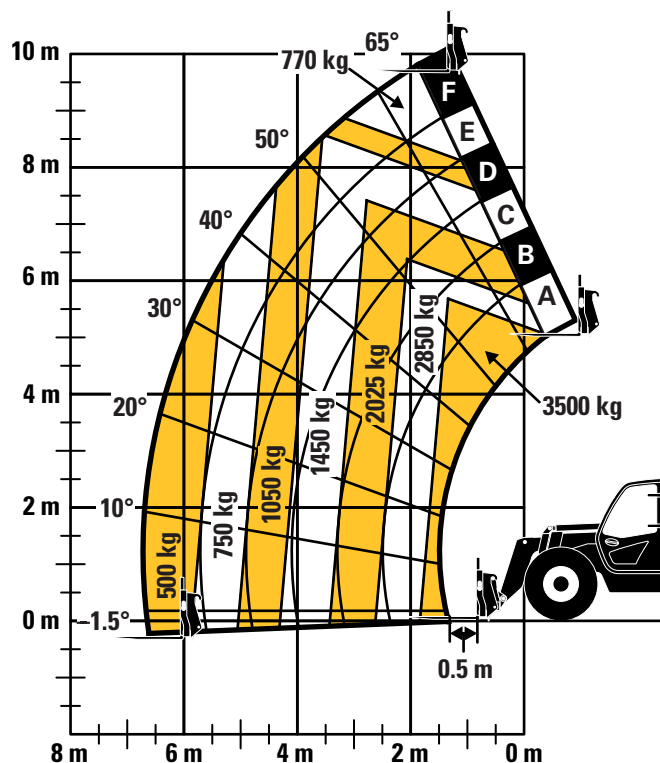

NOTICE

Rated lift capacities shown are with machine equipped with carriage and pallet forks. The machine must be level on a firm surface with undamaged, properly inflated tires. Machine specifications and stability are based on rated lift capacities at specific boom angles and boom lengths. (If specifications are critical, the proposed application should be discussed with your dealer.)

DO NOT exceed rated lift capacity loads, as unstable and dangerous machine conditions will result.

DO NOT tip the machine forward to determine the allowable load.

Use only approved attachments with proper material handler model/attachment load capacity charts displayed in the operator's cab.

Due to continuous product improvements, machine specifications and/or equipment changes may be made without prior notification.

TH3510D Ag Handler

Standard and Optional Equipment (Standard and Optional equipment may vary. Consult your Cat dealer for details.)

	Standard	Optional		Standard	Optional
Cab ROPS and FOPS			Tires		
Longitudinal Stability Indicator	✓	—	Mitas 15.5/80-24 16 ply	✓	—
Reversing Camera	—	✓	Michelin 460/70 R24 XMCL	—	✓
Reversing Sensors	—	✓	Michelin 500/70 R24 XMCL	—	✓
Large Electronic Display Screen	—	✓	Michelin 400/80 24 Power CL	—	✓
Sunscreen	✓	—	Michelin 440/80 24 Power CL	—	✓
Mechanical Suspension Seat with Seat Belt	✓	—	Michelin 460/70 R24 Bibload	—	✓
Air Suspension Seat with Seat Belt	—	✓	Michelin 15.5 R25 XHA	—	✓
Heated Air Suspension Seat with Seat Belt	—	✓	Firestone Duraforce	—	✓
Roof Wiper	✓	—	13 × 24 Solid Tires	—	✓
Screen Guard	—	✓	Tow Hitches		
Roof Guard	✓	—	Retrieval Hitch	—	✓
Heater/De-mister	✓	—	Hydraulic Pick Up Hitch	—	✓
Air Conditioning	—	✓	EEC Manual Hitch	—	✓
Engine Speed Set	✓	—	EEC Automatic Hitch	—	✓
Multi Function Joystick Controller with FNR	✓	—	EEC Automatic Hitch with Piton	—	✓
Column Mounted FNR Lever	—	✓	Trailer Braking Valve	—	✓
Front and Rear Windscreen Wipers	✓	—	Quick Couplers		
Mechanical Parking Brake	✓	—	Manual Cat “IT” Interface	✓	—
SAHR Parking Brake	—	✓	Hydraulic Cat “IT” Interface	—	✓
Electrical			• Competitive couplers are available, please consult your Cat dealer for details.		
1 × 12V 1,000 CCA Battery	✓	—	Work Tools		
2 × 12V 815 CCA Batteries	—	✓	Floating Fork Carriage	—	✓
Block Heater 240 Volt	—	✓	ISO Class 3 Fixed Fork Carriage	—	✓
Work Lights, 4 × Cab Mounted (2 front, 2 rear) 2 × Boom Mounted	—	✓	Side Shift Carriage	—	✓
Product Link™ Ready, Version 641	—	✓	1 m ³ General Purpose Bucket	—	✓
Seven (7) Pin Trailer Service	—	✓	1.5 m ³ Rehandling Bucket	—	✓
Reverse Alarm	✓	—	1.0 m ³ Multi Purpose Bucket	—	✓
Rotating Beacon	—	✓	2.0 m ³ Grain Bucket	—	✓
Other Equipment			2.5 m ³ Grain Bucket	—	✓
Boom Brushes	✓	—	3.0 m ³ Grain Bucket	—	✓
Ride Control with Boom Float	—	✓	Grapple Bucket	—	✓
Single Auxiliary Service to Boom Head	✓	—	Muck Fork and Grapple	—	✓
2 nd Auxiliary Service to Boom Head	—	✓	Bale Handler	—	✓
Auxiliary Service to Rear	—	✓	Sweeper Collector	—	✓
Rear Hitch Mirror, Flat	—	✓			
Rear Hitch Mirror, Convex	—	✓			
Tool Box	—	✓			
Boom Safety Brace	—	✓			

For more complete information on Cat products, dealer services, and industry solutions, visit us on the web at www.cat.com

© 2018 Caterpillar
All rights reserved

Materials and specifications are subject to change without notice. Featured machines in photos may include additional equipment. See your Cat dealer for available options.

CAT, CATERPILLAR, SAFETY.CAT.COM, their respective logos, “Caterpillar Yellow” and the “Power Edge” trade dress, as well as corporate and product identity used herein, are trademarks of Caterpillar and may not be used without permission.

AEHQ7930-01 (01-2018)
Replaces AEHQ7930
(S Am)

