



# Cat<sup>®</sup> TH3510D

## AG HANDLER TELEHANDLER

### FEATURES:

- **Engine Options** – Choose the right engine for you – three fuel efficient Cat<sup>®</sup> engines are available to suit a wide range of applications.
- **Transmission Options** – The Cat TH3510D features a six speed power shift transmission to give exceptional performance when towing trailers on the road.
- **Frame, Boom and Linkage** – Designed for durability. Easy to access greasing points mean a long, trouble free life for the machine. A Z-bar linkage delivers powerful breakout forces and fast cycle times.
- **Powerful Hydraulics** – A variable displacement piston pump matched to a high performance flow sharing valve makes multi functioning easy. The load sensing system means excellent fuel economy, as the pump only works when required.
- **Cab** – The cab is designed with the operator in mind with a multi function joystick and a comfortable working environment. The unique “Operator Preferences” feature allows the machine to be tuned to suit individual operators. Options include a heated air suspension seat, large display screen with pre-loaded load charts, rearview camera, reversing sensors and air conditioning.

## Specifications

### Engine

	Standard	Option 1	Option 2
Model*	Cat C3.4B	Cat C4.4 ACERT™	Cat C4.4 ACERT
Gross power	83 kW (112 hp)	93 kW (124 hp)	106 kW (142 hp)
Maximum torque	460 N·m (339 lbf·ft)	530 N·m (391 lbf·ft)	560 N·m (413 lbf·ft)
Bore	99 mm (3.8 in)	105 mm (4.1 in)	105 mm (4.1 in)
Stroke	110 mm (4.3 in)	127 mm (5 in)	127 mm (5 in)
Displacement	3.4 L (207 in <sup>3</sup> )	4.4 L (269 in <sup>3</sup> )	4.4 L (269 in <sup>3</sup> )

\*Meets U.S. EPA Tier 4 Final emission standards.

### Weights

Operating Weight with Carriage and Forks*	9149 kg	20,170 lb
---	---------	-----------

\*Represents machine configuration of 106 kW (142 hp) engine on standard 15.5/80-24 16 ply tires.

### Operating Specifications

Rated Load Capacity	3493 kg	7,700 lb
Maximum Lift Height	9.8 m	32.1 ft
Capacity at Maximum Lift Height	635 kg	1,400 lb
Maximum Forward Reach	6.6 m	21.6 ft
Capacity at Maximum Forward Reach	578 kg	1,275 lb
Outside Turning Radius over Tires	3.85 m	12.6 ft
Outside Turning Radius over Forks	4.88 m	15.9 ft

### Service Refill Capacities

Fuel Tank	148 L	40 gal
Diesel Exhaust Fluid	19 L	5.0 gal
Hydraulic Tank	120 L	31.7 gal

### Brakes

Service Brakes	Boost assisted on front and rear brakes
Parking Brake	Mechanical lever on front axle

### Transmission\*

Type	Cat PG124 six speed power shift	
Forward		
1	5.7 km/h	3.4 mph
2	8.6 km/h	5.3 mph
3	11.2 km/h	6.9 mph
4	16.6 km/h	10.3 mph
5	25.3 km/h	15.7 mph
6	40 km/h	24.9 mph
Reverse		
1	5.7 km/h	3.4 mph
2	11.2 km/h	6.9 mph
3	25.3 km/h	15.7 mph

\*Travel speed is subject to machine configuration.



# TH3510D Ag Handler Telehandler

## Electrical

Battery	1 × 12V 1,000 CCA Battery
Alternator Output	12V/150A

## Hydraulic System

System Type	Load Sensing, Closed Center	
Pump Type	Variable Flow, Axial Piston	
Maximum Pump Capacity	140 L/min	36.9 gal/min
System Pressure	260 bar	3,770 psi
Auxiliary Hydraulic Pressure	245 bar	3,553 psi
Auxiliary Hydraulic Flow		
Boom Head – Intermittent	95 L/min	25 gal/min
Boom Head – Continuous	95 L/min	25 gal/min
Machine Rear	80 L/min	21 gal/min

## Boom Performance

Boom Up	8 sec
Boom Down	6.5 sec
Tele Out	11 sec
Tele In	10.5 sec
Crowd Forward (Dump)	3 sec
Crowd Backward	3.5 sec
Combined	
Up and Out	24 sec
Down and In	12.8 sec

## Axles

Front Axle	High bias, planetary reduction hubs with limited slip differential
Rear Axle	Open differential with planetary reduction hubs

## Tires

Standard	Mitas 15.5/80-24 16 ply
Options	Michelin 15.5 R25 XHA Michelin 460/70 R24 XMCL Michelin 500/70 R24 XMCL Michelin 440/80 24 Power CL Michelin 400/80 24 Power CL Michelin 460/70 R24 Bibload Firestone Duraforce 13 × 24 Solid Tires

## Performance

Drawbar Pull		
83 kW/111.3 hp Engine	92 kN	20,682 lbf
92.6 kW/124.1 hp Engine	88 kN	19,783 lbf
106 kW/142.1 hp Engine	97 kN	21,806 lbf
Boom Breakout Force	41 kN	9,217 lbf
Bucket Breakout Force	62 kN	13,938 lbf
Quick Coupler Rotation	152°	
Noise Levels		
In Cab	74 dB(A)	
External	106 dB(A)	
Towable Mass		
Hydraulically Braked	12 000 kg	26,455 lb

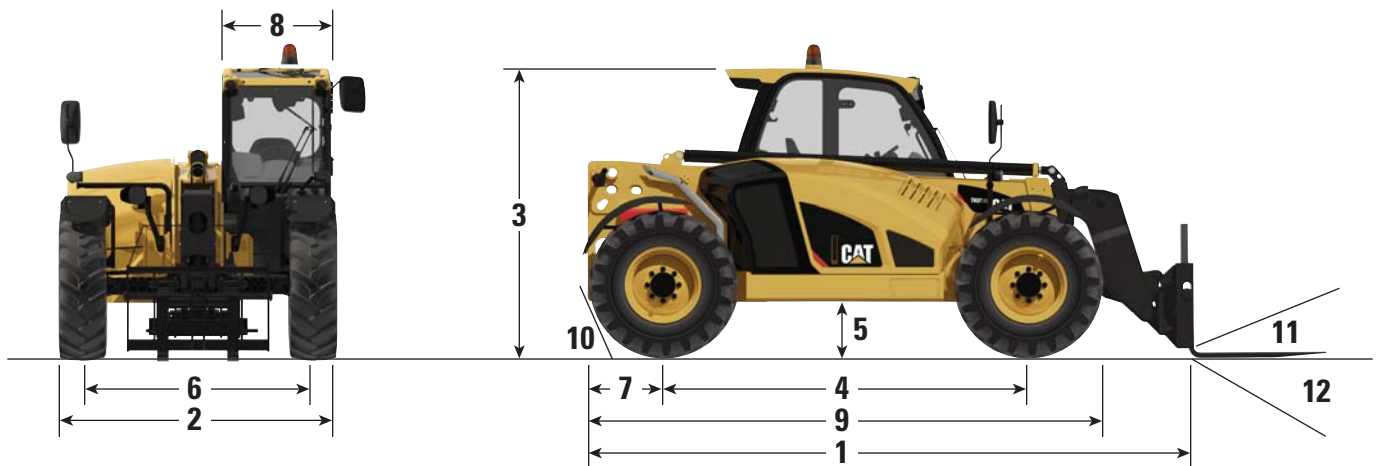

## Dimensions (All dimensions are approximate.)

<b>1</b> Overall Length to Front of Carriage	5300 mm	17.4 ft	<b>7</b> Overhang	1000 mm	3.3 ft
<b>2</b> Overall Width (standard tires)	2382 mm	7.8 ft	<b>8</b> Cab Width	900 mm	3.0 ft
<b>3</b> Overall Height (standard tires)*	2475 mm	8.1 ft	<b>9</b> Machine Length	5260 mm	17.3 ft
<b>4</b> Wheelbase	3165 mm	10.3 ft	<b>10</b> Departure Angle	60°	
<b>5</b> Ground Clearance	430 mm	1.4 ft	<b>11</b> Maximum Fork Crowd Angle	24°	
<b>6</b> Track	1988 mm	6.5 ft	<b>12</b> Maximum Fork Dump Angle	128°	

\*Add 200 mm (7.9 in) for beacon.  
Add 40 mm (1.6 in) for top guard.

## Load Chart and Dimensions

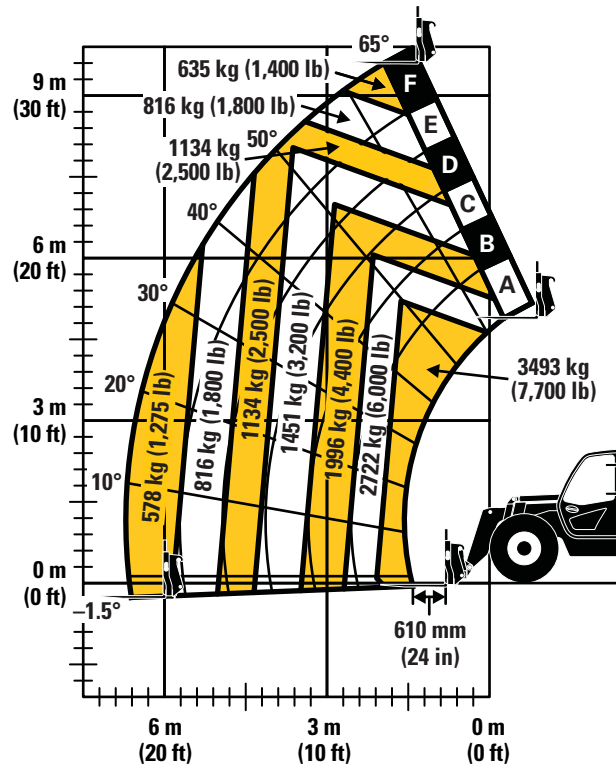

### IMPORTANT

Rated lift capacities shown are with machine equipped with carriage and pallet forks. The machine must be level on a firm surface with undamaged, properly inflated tires. Machine specifications and stability are based on rated lift capacities at specific boom angles and boom lengths. (If specifications are critical, the proposed application should be discussed with your dealer.)

DO NOT exceed rated lift capacity loads, as unstable and dangerous machine conditions will result.

DO NOT tip the machine forward to determine the allowable load.

Use only approved attachments with proper material handler model/attachment load capacity charts displayed in the operator's cab. OSHA requires all rough terrain forklift operators be trained according to OSHA 29 CFR 1910.178 (1).

*Due to continuous product improvements, machine specifications and/or equipment changes may be made without prior notification. This machine meets or exceeds ANSI/ITSDF B56.6-2005 as originally manufactured for intended applications.*

# TH3510D Ag Handler Telehandler

**Standard and Optional Equipment** (Standard and Optional equipment may vary. Consult your Cat dealer for details.)

	Standard	Optional		Standard	Optional
<b>Cab ROPS and FOPS</b>			<b>Tires</b>		
Reversing Camera	—	✓	Mitas 15.5/80-24 16 ply	✓	—
Reversing Sensors	—	✓	Michelin 460/70 R24 XMCL	—	✓
Large Electronic Display Screen	—	✓	Michelin 500/70 R24 XMCL	—	✓
Sunscreen	✓	—	Michelin 400/80 24 Power CL	—	✓
Mechanical Suspension Seat with Seat Belt	✓	—	Michelin 440/80 24 Power CL	—	✓
Air Suspension Seat with Seat Belt	—	✓	Michelin 460/70 R24 Bibload	—	✓
Heated Air Suspension Seat with Seat Belt	—	✓	Michelin 15.5 R25 XHA	—	✓
Roof Wiper	✓	—	Firestone Duraforce	—	✓
Screen Guard	—	✓	13 × 24 Solid Tires	—	✓
Roof Guard	✓	—	<b>Tow Hitches</b>		
Heater/De-mister	✓	—	Retrieval Hitch	—	✓
Air Conditioning	—	✓	Hydraulic Pick Up Hitch	—	✓
Engine Speed Set	✓	—	EEC Manual Hitch	—	✓
Multi Function Joystick Controller with FNR	✓	—	EEC Automatic Hitch	—	✓
Column Mounted FNR Lever	—	✓	EEC Automatic Hitch with Piton	—	✓
Front and Rear Windscreen Wipers	✓	—	Trailer Braking Valve	—	✓
Mechanical Parking Brake	✓	—	<b>Quick Couplers</b>		
SAHR Parking Brake	—	✓	Manual Cat “IT” Interface	✓	—
<b>Electrical</b>			Hydraulic Cat “IT” Interface	—	✓
1 × 12V 1,000 CCA Battery	✓	—	<b>Work Tools</b>		
2 × 12V 815 CCA Batteries	—	✓	Floating Fork Carriage	—	✓
Block Heater 110 Volt	—	✓	ISO Class 3 Fixed Fork Carriage	—	✓
Work Lights, 4 × Cab Mounted (2 front, 2 rear) 2 × Boom Mounted	—	✓	Side Shift Carriage	—	✓
Product Link™ Ready, Version 641	—	✓	1 m <sup>3</sup> (1.3 yd <sup>3</sup> ) General Purpose Bucket	—	✓
Seven (7) Pin Trailer Service	—	✓	1.5 m <sup>3</sup> (1.95 yd <sup>3</sup> ) Rehandling Bucket	—	✓
Reverse Alarm	✓	—	1.0 m <sup>3</sup> (1.3 yd <sup>3</sup> ) Multi Purpose Bucket	—	✓
Rotating Beacon	—	✓	2.0 m <sup>3</sup> (2.6 yd <sup>3</sup> ) Grain Bucket	—	✓
<b>Other Equipment</b>			2.5 m <sup>3</sup> (3.25 yd <sup>3</sup> ) Grain Bucket	—	✓
Boom Brushes	✓	—	3.0 m <sup>3</sup> (3.9 yd <sup>3</sup> ) Grain Bucket	—	✓
Ride Control with Boom Float	—	✓	Grapple Bucket	—	✓
Single Auxiliary Service to Boom Head	✓	—	Muck Fork and Grapple	—	✓
2 <sup>nd</sup> Auxiliary Service to Boom Head	—	✓	Bale Handler	—	✓
Auxiliary Service to Rear	—	✓	Sweeper Collector	—	✓
Rear Hitch Mirror, Flat	—	✓			
Rear Hitch Mirror, Convex	—	✓			
Tool Box	—	✓			

For more complete information on Cat products, dealer services, and industry solutions, visit us on the web at [www.cat.com](http://www.cat.com)

© 2018 Caterpillar  
All rights reserved

Materials and specifications are subject to change without notice. Featured machines in photos may include additional equipment. See your Cat dealer for available options.

CAT, CATERPILLAR, SAFETY.CAT.COM, their respective logos, “Caterpillar Yellow” and the “Power Edge” trade dress, as well as corporate and product identity used herein, are trademarks of Caterpillar and may not be used without permission.

AEHQ8040-01 (01-2018)  
Replaces AEHQ8040  
(Americas North)

