

# INV2000 Inverter Generator

EPA, CARB, CSA (522-2700)



1800 W Running | 2250 W Starting

## Features

- Quiet running: meets National Park Service campground requirements
- Clean, regulated A/C power for sensitive electronics (< 3% THD)
- Safety compliant for worksite use (OSHA compliant)
- 2x USB Ports, including a 2.1 Amp port for charging your tablet
- DOUBLE your power by paralleling with another INV2000
- Engine is EPA Certified to last 20% longer than the competition

 Up to 6 Hours Run Time @ 50% Load

 Fuel Efficient 79.7 cc OHV Engine

 Engine Smart Control (ESC) automatically adjusts power for your needs

 Easy serviceability with custom, drip-free oil funnel and oil fill access

 Access door for air filter and fuel drain

 Automatic Low Oil Shutdown Protection

Because of continuing improvements, actual product may differ slightly from this photo.

## Control Panel

 LED Illuminated Control Panel for Night Operation

 Low Oil, Overload and Running LED Notifications

 Single operation knob with integrated choke

 Engine Smart Control (ESC)

 Dual USB ports (2.1A and 1.0A) with snap-fit rubber cover

 Snap-fit Rubber Covered GFCI Duplex Receptacle

 12 VDC plug with automotive battery charging cord

 Parallel Connection

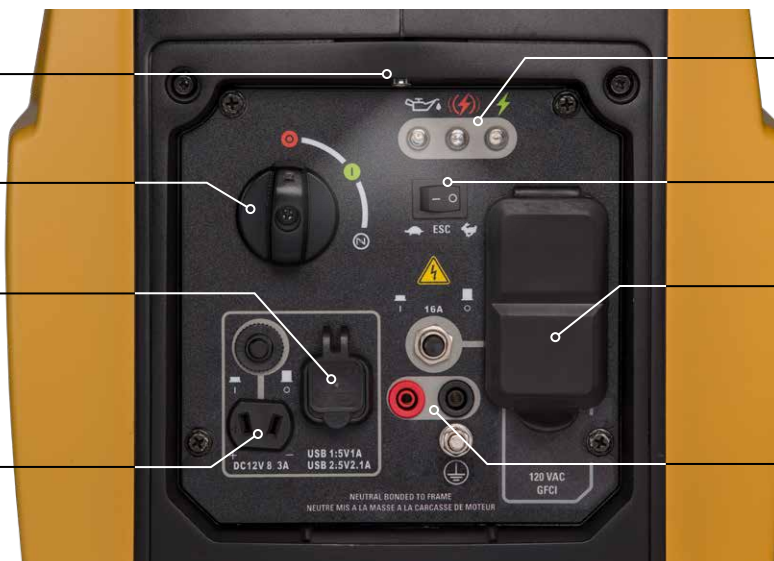

# INV2000 Inverter Generator

EPA, CARB, CSA (522-2700)



## Specifications

ENGINE	
Starting Method	Pull
Run Time @ 50% Load	6 hours
Idle Control	Engine Smart Control (ESC)
Fuel Tank Nominal Capacity	1 gal / 4 L
Fuel Tank Material	Plastic
Fuel Type	Unleaded Gasoline $\geq$ 87 octane*
Fuel Gauge	Dial Gauge
Engine Displacement	79.7 cc
Engine Type	OHV
Engine Speed	Variable RPM
Lubrication Method	Splash
Recommended Oil	SAE 30 or 10W-30
Oil Capacity	0.4 qt / 0.380 L
Region Certifications	EPA, CARB, CSA
Shutdown Method	Automatic Low Oil Level

ELECTRICAL	
Running Power	1800 Watts
Starting Power	2250 Watts
AC Output	120V @ 60 Hz
DC Output	12V (8.3A) / 5V (2.1A)
Total Harmonic Distortion (THD)	< 3%
Receptacles	2x 5-20R GFCI, 1x 5V 2.1A USB, 1x 5V 1.0A USB, 1x 12 VDC 8.3A
Voltage Regulation	Inverter Type
Battery Type	-

EXTRA FEATURES	
Illuminated Control Panel	Yes
Handle Style	Integrated
Wheel Type	-
Indicator Lights	Low Oil, Overload, and Running
USB	1x 2.1A 5V and 1x 1.0A 5V

**WARRANTY** Standard 2-year limited, extended 3-year limited when registered within 30 days

\*No more than 10% ethanol; fuel stabilizer should also be used for storage

## Dimensions and Weights

ASSEMBLED	
Height	18.1 in / 460 mm
Width	12.5 in / 318 mm
Length	19.6 in / 497 mm
Extended Length	-
Unit Weight (Dry)	48.8 lbs / 22.1 kg

CARTON	
Height	21.5 in / 545 mm
Width	16.0 in / 406mm
Length	24.0 in / 610 mm
Shipping Weight	57.3 lbs / 26 kg

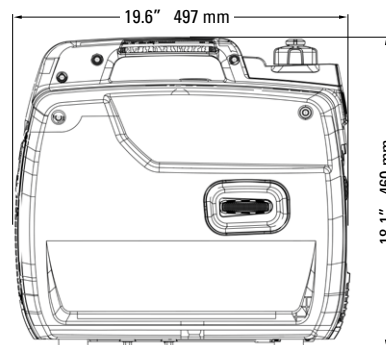
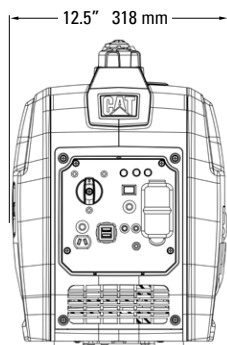

**CATERPILLAR®**

© 2018 Caterpillar. All Rights Reserved.  
CAT, CATERPILLAR, their respective logos, "Caterpillar Yellow," the "Power Edge" trade dress, as well as corporate and product identity used herein, are trademarks of Caterpillar and may not be used without permission.



For more information:  
[cat.com/homeandoutdoorpower](http://cat.com/homeandoutdoorpower)

## Accessories

Parallel Kit - INV2000 (530-1202)



INV2000 Protective Cover (517-9207)



INV2000 Service Kit (517-9208)



LEHQ0060-02