



**Disassembly and Assembly
414E, 416E, 420E, 422E, 428E, 430E, 432E, 434E, 442E and 444E
Backhoe Loaders Power Train**

Media Number -REN6475-12

Publication Date -01/09/2012

Date Updated -21/09/2012

i02756226

Transmission (Direct Drive) - Assemble

SMCS - 3030-016-DD ; 3066-016

Assembly Procedure

Table 1

Required Tools			
Tool	Part Number	Part Description	Qty
A	1U-5750	Engine Stand	1
B	6V-2157	Link Bracket	2
D	4C-3652	Spring Compressor	1
G	1P-1859	Retaining Ring Pliers	1
H	8T-5096	Indicator	1
J	1P-0510	Driver Gp	1
K	4C-9507	Retaining Compound	1
L	1U-8846	Gasket Sealant	1
M	1H-9721	Expansion Plug	1

Note: The transmission will be assembled in major components. The major components will then be assembled.

Note: Cleanliness is an important factor. Before assembly, all parts should be thoroughly cleaned in cleaning fluid. Allow the parts to air dry. Wiping cloths or rags should not be used to dry parts. Lint may be deposited on the parts which may cause later trouble. Inspect all parts. If any parts are worn or damaged, use new parts for replacement.

Note: Apply a light film of clean transmission oil to all components before assembly.

Transmission case

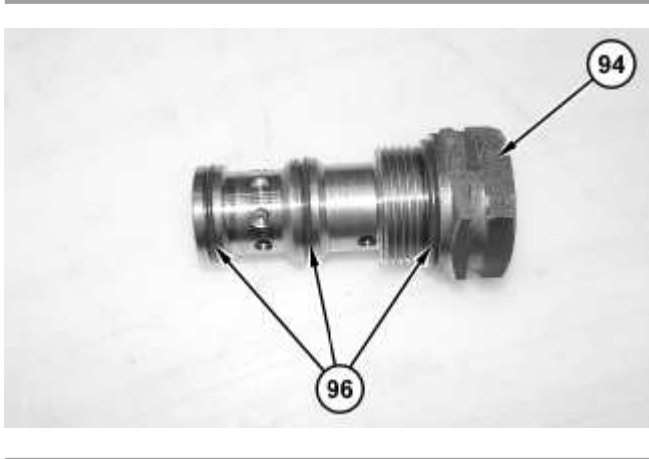

Illustration 1

g01379306

1. Install O-ring seals (96) onto relief valve (94) .

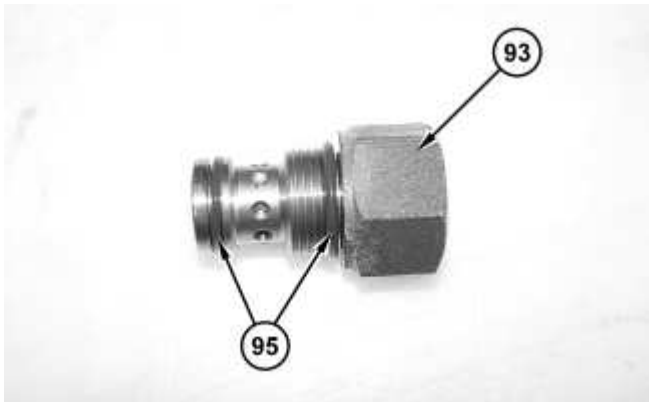

Illustration 2

g01379305

2. Install O-ring seals (95) onto converter relief valve (93) .
-

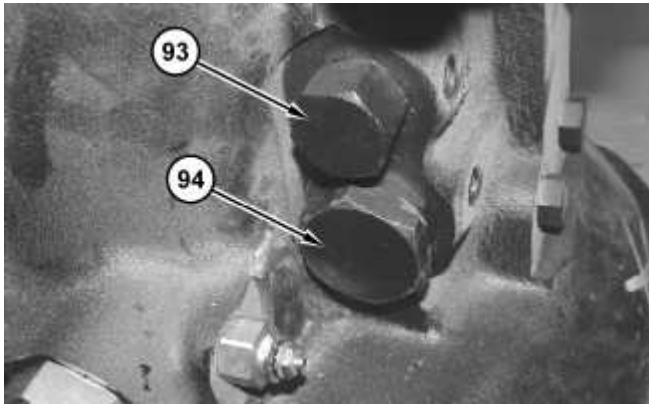

Illustration 3

g01379293

3. Install converter relief valve (93) and relief valve (94). Tighten converter relief valve (93) to a torque of 23 N·m (17 lb ft) to 30 N·m (22 lb ft). Tighten relief valve (94) to a torque of 46 N·m (34 lb ft) to 60 N·m (44 lb ft).



Illustration 4

g01379291

4. Follow the following procedure in order to install speed sensor (92).
 - a. Hand tighten the sensor until the end of the sensor makes contact with the gear.
 - b. Turn the sensor counterclockwise between a half of a turn and a full turn. This will set the air gap to 1.42 mm (0.056 inch).
 - c. Tighten the locknut to a torque of 26 N·m (19 lb ft) after adjustment of the sensor. Secure the locknut with Tooling (L).

Note: Do not allow the sensor to turn as the locknut is tightened.

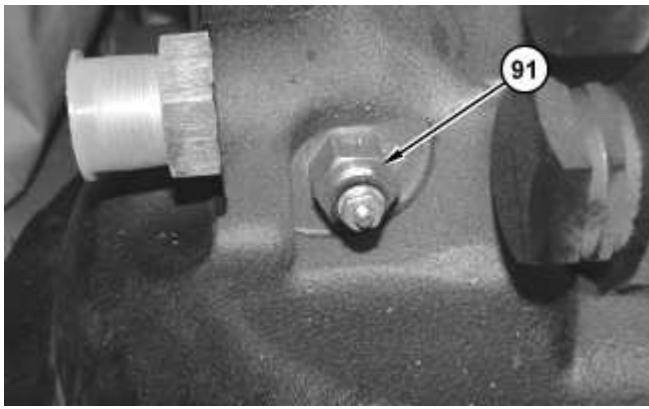

Illustration 5

g01379287

5. Install temperature sensor (91). Tighten temperature sensor (91) to a torque of 18 N·m (13 lb ft) to 24 N·m (18 lb ft).

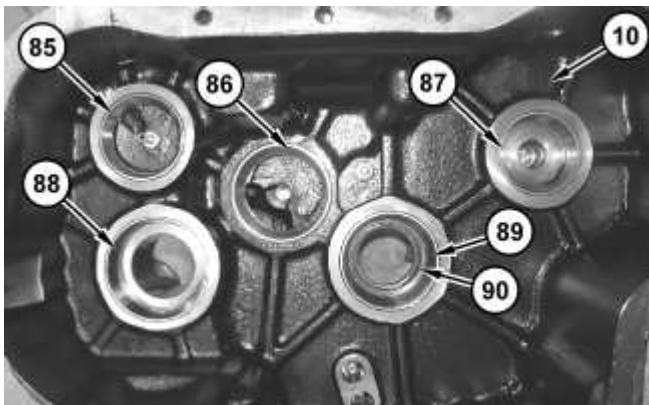

Illustration 6

g01378845

Note: Install the shims behind each bearing cup that was recorded on the disassembly procedure.

6. Install bearing cup (85), bearing cup (86), bearing cup (87), and bearing cup (88) into case (10). Install bearing cup (89) and seal (90) from case (10) .

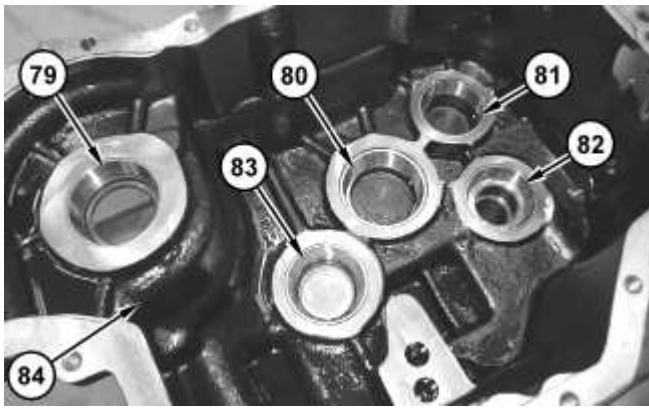

Illustration 7

g01378836

7. Install bearing cup (79), bearing cup (80), bearing cup (81), bearing cup (82), and bearing cup (83) into case (84). Use Tooling (J) in order to install the lip seal into case (84) .

Direct Drive, Input Shaft

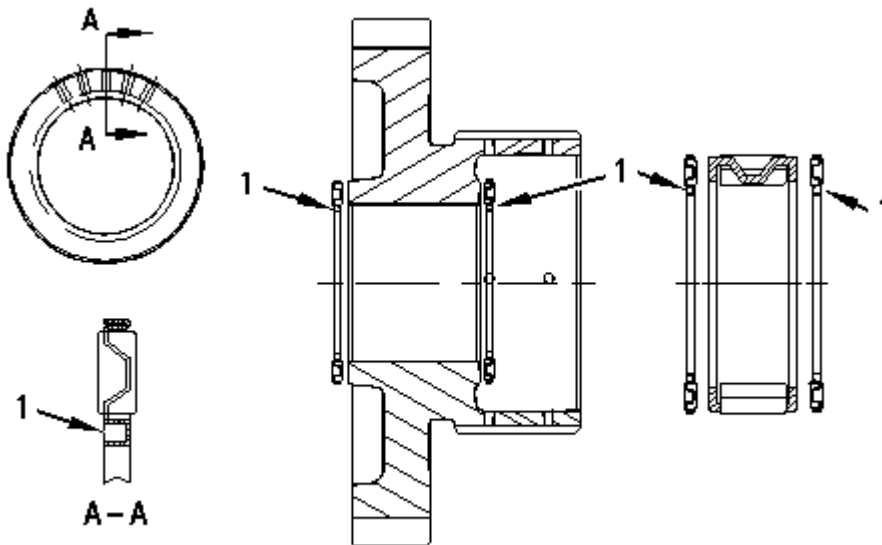

Illustration 8

g00731364

1. Install the needle thrust bearings on the shafts. The open end of cups (1) must point away from the bearings or gears that are contacted.

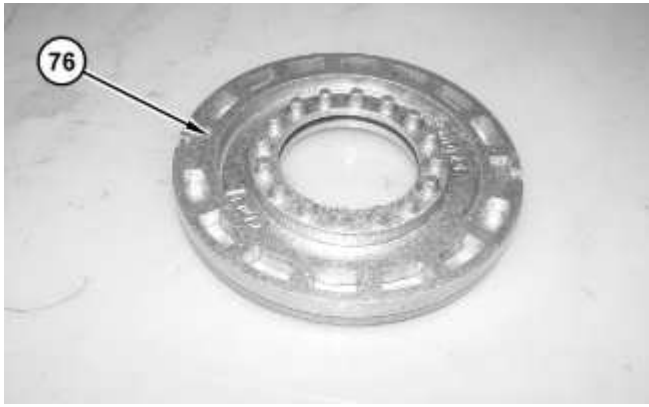

Illustration 9

g01378765

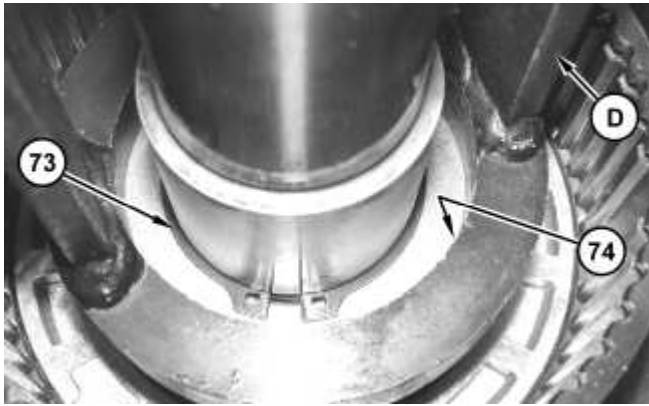

Illustration 10

g01378752

WARNING

Personal injury can result from being struck by parts propelled by a released spring force.

Make sure to wear all necessary protective equipment.

Follow the recommended procedure and use all recommended tooling to release the spring force.

2. Install the O-ring seal and the seal ring into piston (76) .
3. Install piston (76). Install the retainer and spring (73). Use Tooling (D) and a suitable press in order to compress spring (74). Use Tooling (G) in order to install retaining ring (73) .



Illustration 11

g01378746

4. Install clutch pack (72) and retainer ring (71) .
5. Repeat Steps 2 through 4 for the opposite end of the input shaft.

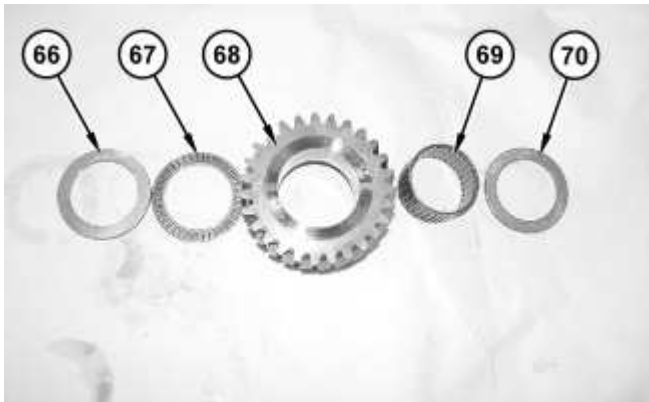

Illustration 12

g01378739

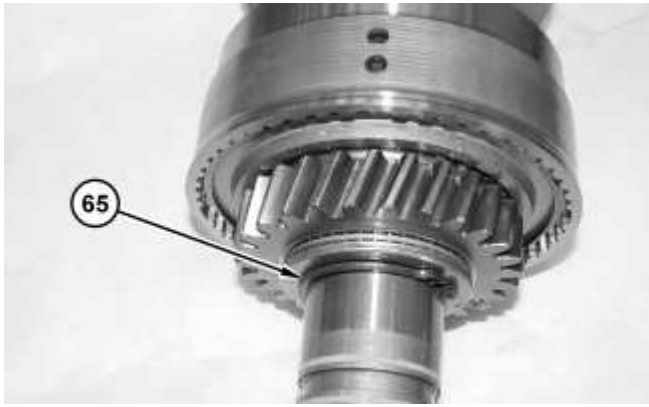

Illustration 13

g01378721

6. Install gear (68), needle bearing (69), thrust bearing (67), and washers (70) and (66). Use Tooling (G) in order to install retaining ring (65) .

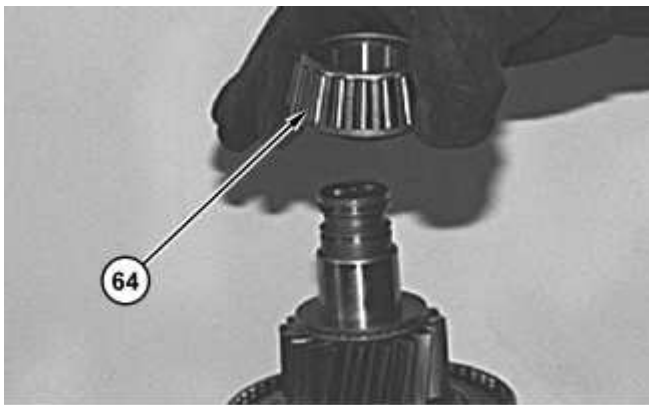
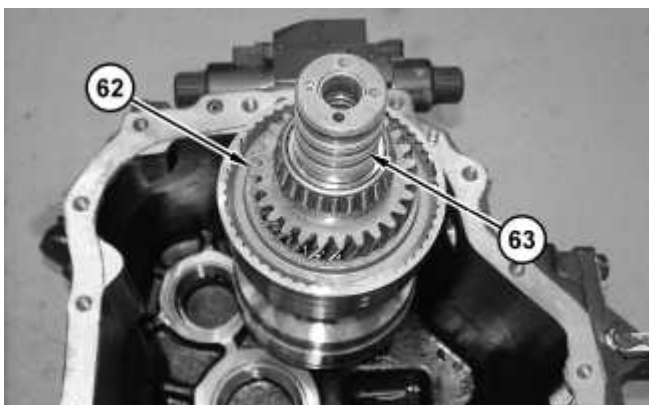

Illustration 14

g01381071

7. Raise the temperature of bearing cone (64). Install bearing cone (64) .



8. Install sealing rings (63). Install input shaft (62) .

Direct Drive, Reverse Shaft



Illustration 16

1. Raise the temperature of bearing cones (61) and (60) . Install bearing (61) and bearing (60) .



Illustration 17

2. Install reverse shaft (59) .

Direct Drive Shaft

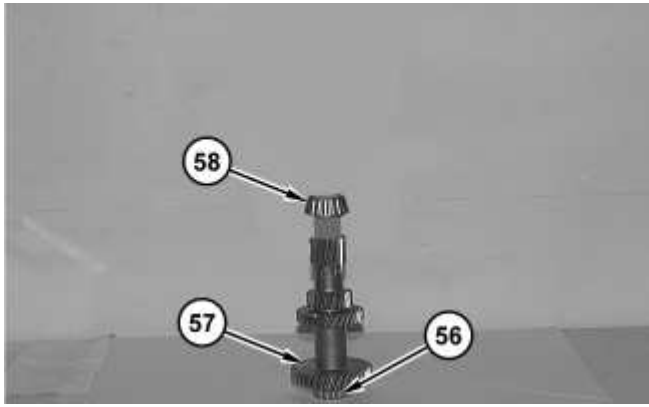

Illustration 18

g01380144

1. Install gear (57) .
2. Apply Tooling (K) to the shaft. Raise the temperature of bearing cone (56) and bearing cone (58). Install bearing cone (56) and bearing cone (58) .



Illustration 19

g01378673

3. Install direct drive shaft (55) .

Direct Drive, Rear Output Shaft



Illustration 20

g01381096

1. Apply Tooling (K) to the shaft. Install gear (54) .

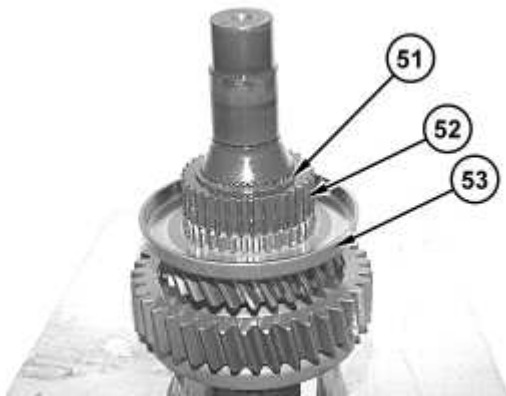

Illustration 21

g01381002

2. Install housing (53) and gear (52). Use Tooling (G) in order to install retaining ring (51) .

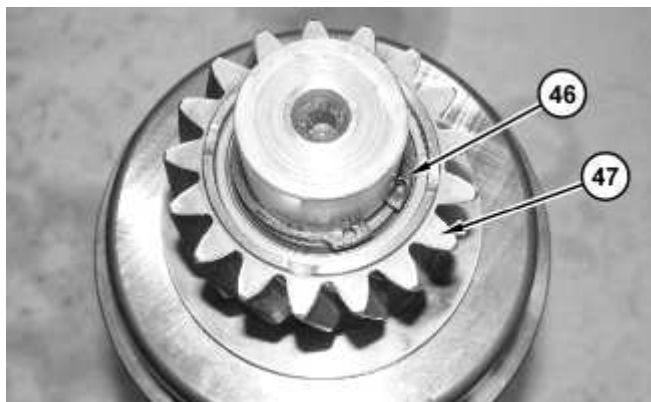

Illustration 22

g01378663

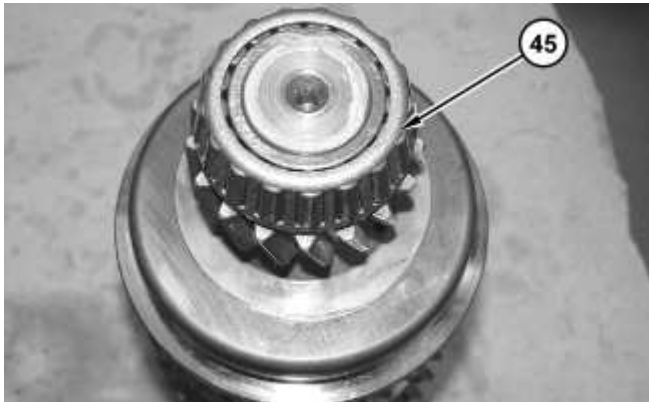

Illustration 23

g01378660

3. Install gear (47). Use Tooling (G) in order to install retaining ring (46). Raise the temperature of bearing cone (45). Install bearing cone (45) .

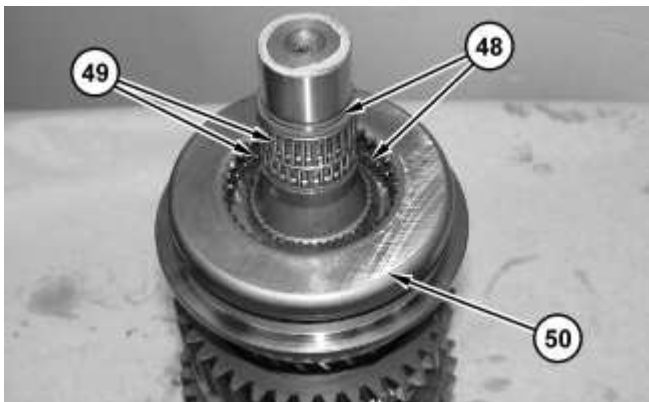

Illustration 24

g01378670

4. Install synchronizer (50). Install spacers (48). Raise the temperature of bearing (49). Install bearing (49) .
-

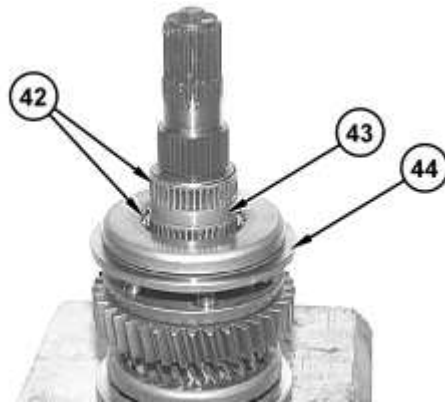

Illustration 25

g01380980

5. Install synchronizer (44), spacer (43), and bearings (42) .

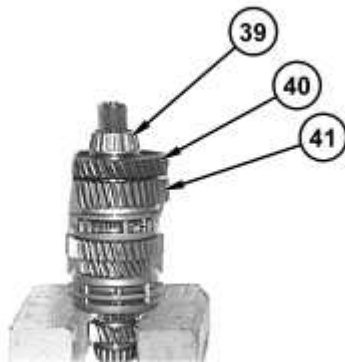

Illustration 26

g01381107

6. Install gears (41) and (40). Raise the temperature of bearing cone (39). Install bearing cone (39) .
7. Install the rear output shaft in the transmission.
-

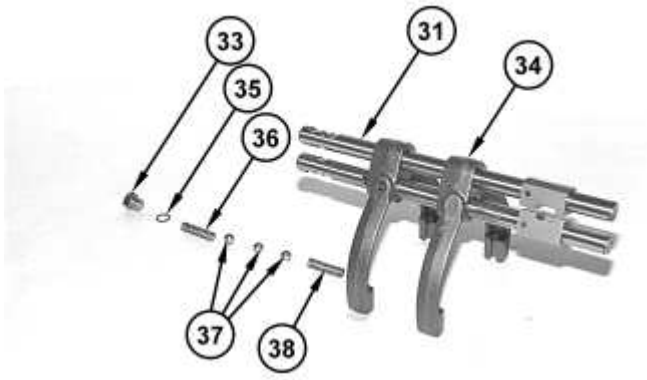

Illustration 27

g01380953

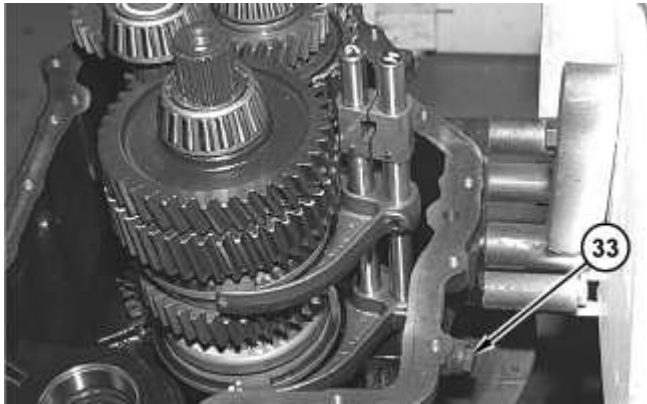

Illustration 28

g01380952

WARNING

Personal injury can result from being struck by parts propelled by a released spring force.

Make sure to wear all necessary protective equipment.

Follow the recommended procedure and use all recommended tooling to release the spring force.

-
8. Install gearshift rods (31) on shift forks (34). Install the gearshift rods in the transmission. Install balls (37), springs (38) and (33), and O-ring seal (35). Install plug (33). Tighten plug (33) to a torque of 40 N·m (30 lb ft) to 54 N·m (40 lb ft).
-

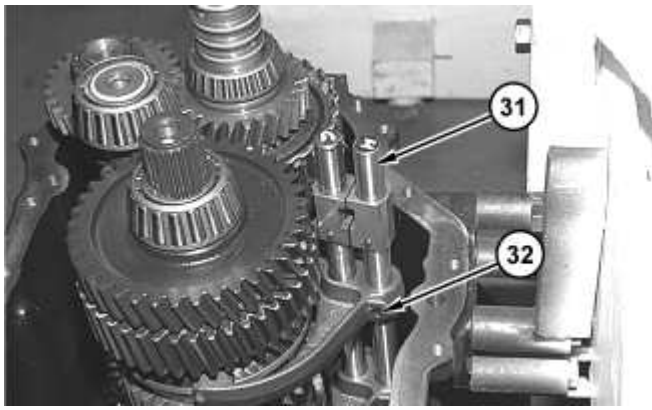

Illustration 29

g01380950

9. Install screws (32) on each of the gearshift rods (31) .

Direct Drive, Front Output Shaft

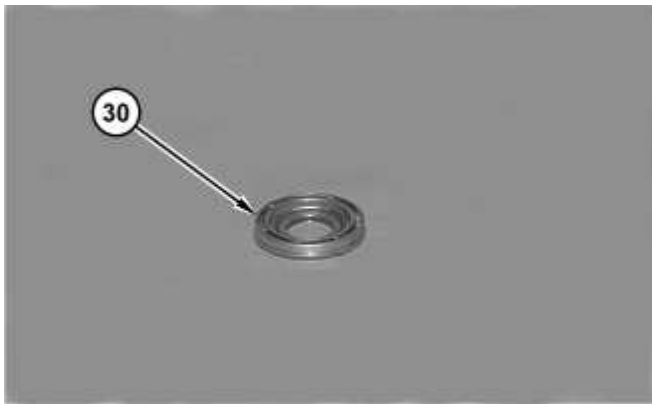

Illustration 30

g01381112

1. Install seals on piston (30) .

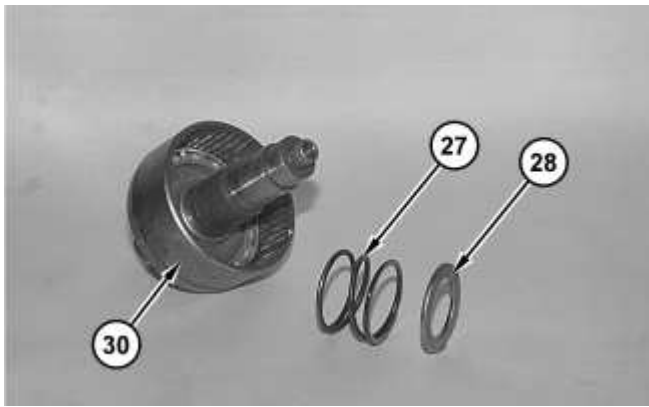

Illustration 31

g01381116

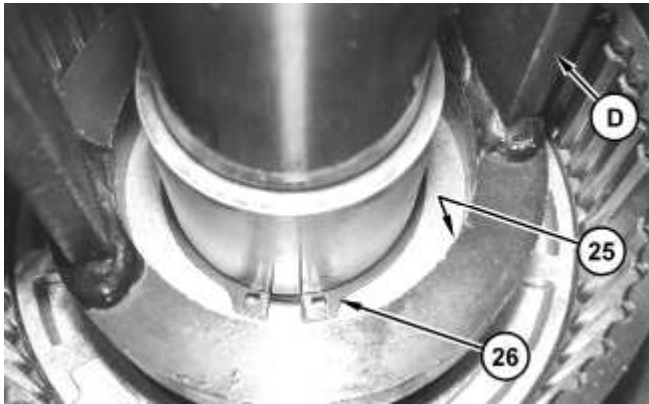

Illustration 32

g01378622

WARNING

Personal injury can result from being struck by parts propelled by a released spring force.

Make sure to wear all necessary protective equipment.

Follow the recommended procedure and use all recommended tooling to release the spring force.

2. Install spring (27) and retainer (28) into piston (30) .
3. Use Tooling (D) and a suitable press in order to compress spring (25). Use Tooling (G) in order to install retaining ring (26) .

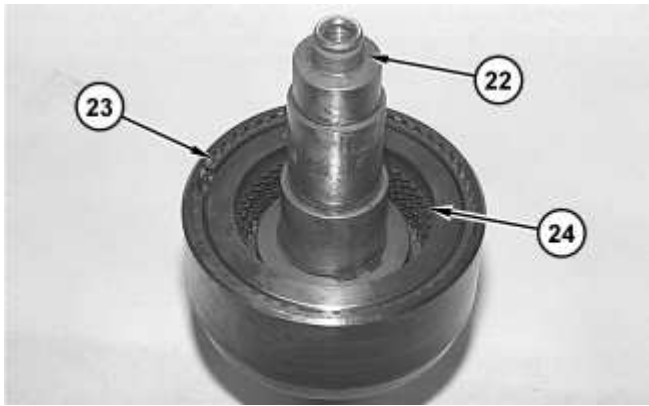

Illustration 33

g01380592

4. Install sealing ring (22). Install clutch pack (24) and retainer ring (23) .

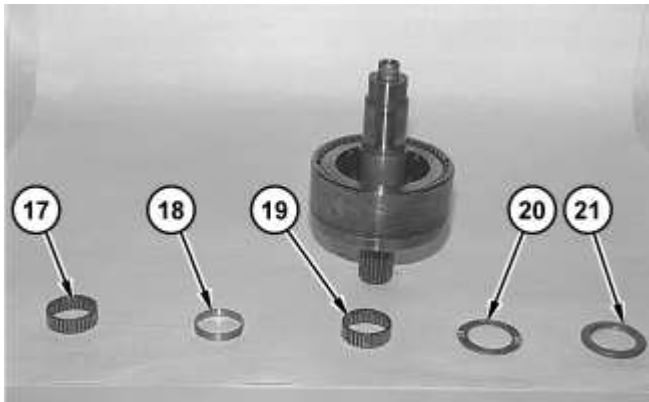

Illustration 34

g01380797

5. Install thrust washer (21), needle bearing (20), roller bearing (19), spacer (18), and roller bearing (17) .
-

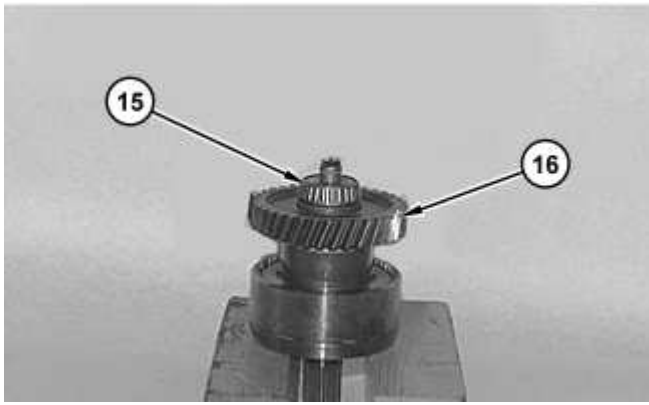

Illustration 35

g01380240

6. Install gear (16) .
7. Raise the temperature of bearing cone (15). Install bearing cone (15) .



Illustration 36

g01381124

8. Raise the temperature of bearing cone (14). Install bearing cone (14) .
-



Illustration 37

g01380786

9. Install front output shaft (13) .

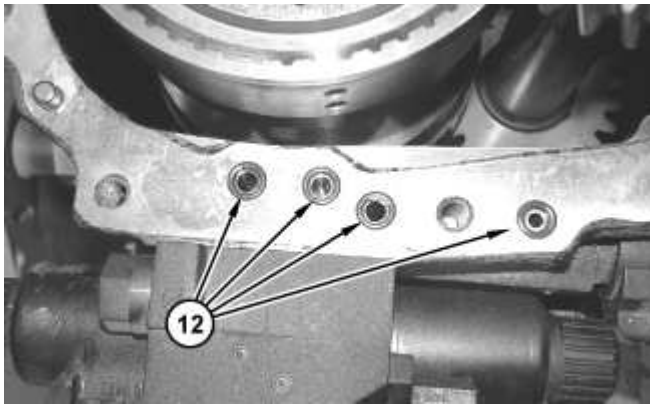

Illustration 38

g01378615

10. Install O-ring seals (12) .

Final Assembly

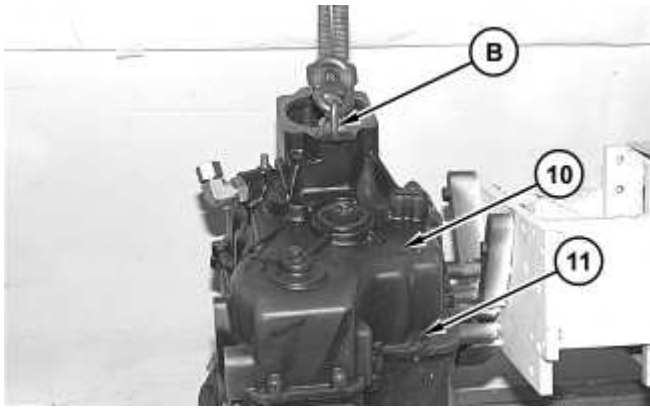

Illustration 39

g01380244

Note: Clean the mating surfaces of case (10). Apply Tooling (H) to the mating surface of the case.

1. Attach Tooling (B) to case (10). Attach a suitable lifting device to Tooling (B). Use bolts (11) in order to install case (10). The weight of case (10) is 42 kg (94 lb). Tighten bolts (11) to a torque of 45 N·m (33 lb ft) to 65 N·m (48 lb ft).

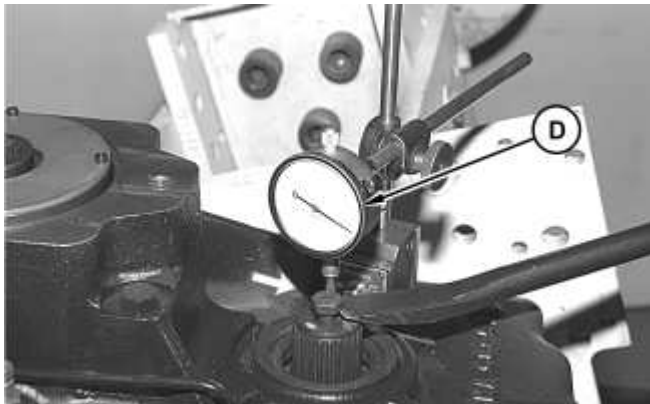

Illustration 40

g01380247

2. Install a bolt in the output shaft. The output shaft must be fully seated. Install Tooling (H), as shown. Zero Tooling (H). Pry up on the bolt and record the reading on Tooling (H). The reading must be 0.03 mm (0.0012 inch) to 0.08 mm (0.0031 inch). Add or remove shims in Step 7 in the Case Assembly Procedure in order to obtain the correct reading.



Illustration 41

g00730086

3. Repeat Step 7 for the input shaft and the output shaft (front). Use the same tolerance for all of the shafts. Remove the expansion plug in order to check the input shaft. Use a screwdriver to pry up on the input shaft. Install Tooling (J) .

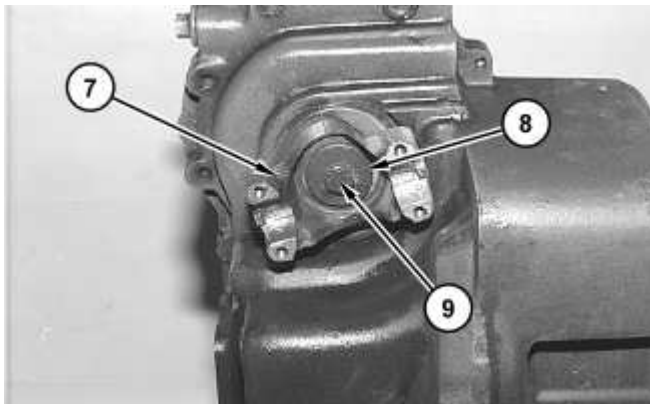

Illustration 42

g01380773

4. Install yoke (7), washer (8), and bolt (9). Tighten bolt (9) to a torque of 68 N·m (50 lb ft) to 88 N·m (65 lb ft).

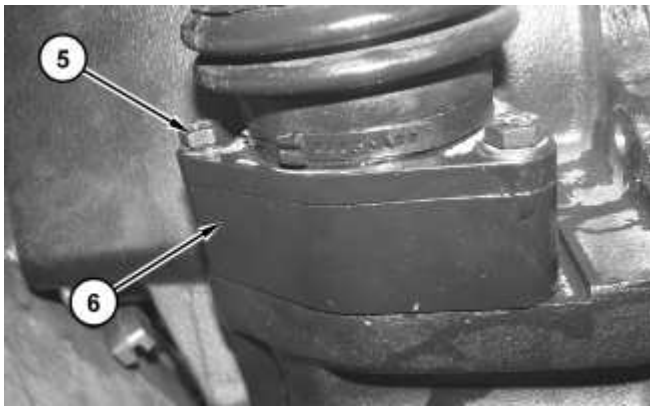

Illustration 43

g01379269

5. Position gear shift (6) and install bolts (5) .

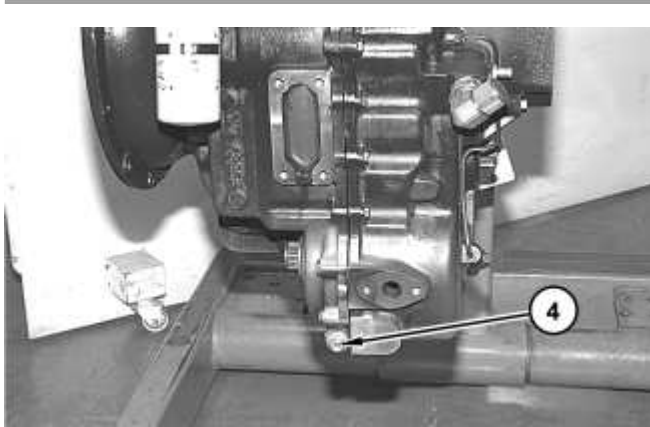

Illustration 44

g01380772

6. Install plug (4). Tighten plug (4) to a torque of 40 N·m (30 lb ft) to 54 N·m (40 lb ft).

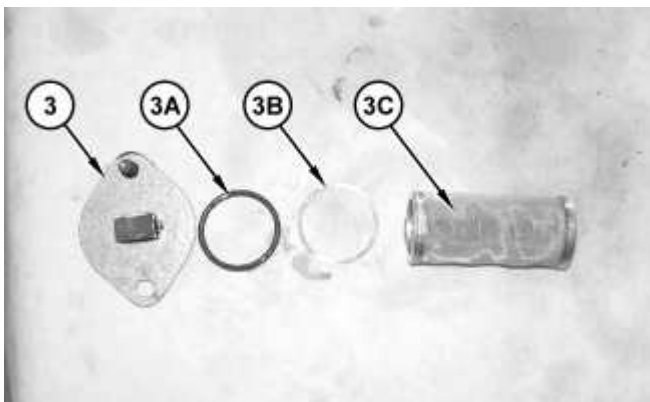



Illustration 46

g01380069

7. Install screen (3C). Install spacer (3B) and O-ring seal (3A). Install cover (3) .

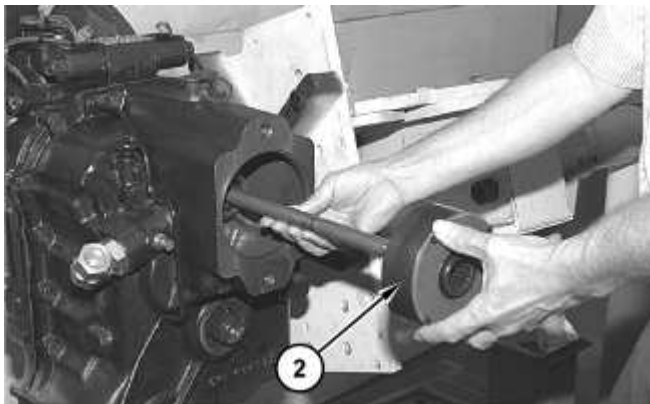

Illustration 47

g01381134

8. Install Implement pump drive shaft (2) into the transmission.
-

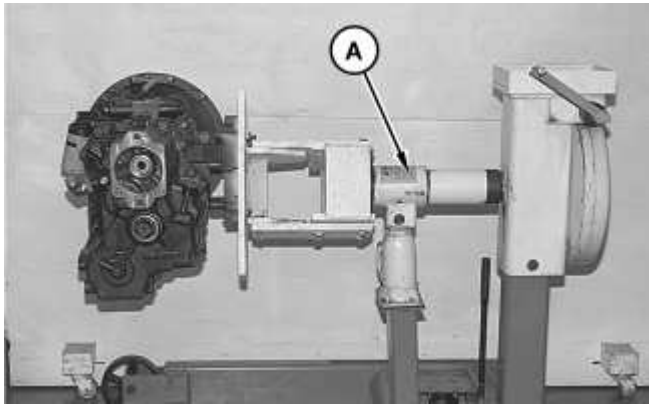

Illustration 48

g01380447

9. Remove the transmission from Tooling (A) .

End By: Install the transmission. Refer to Disassembly and Assembly, "Transmission (Direct Drive) - Install".

[Copyright 1993 - 2017 Caterpillar Inc.](#)

[All Rights Reserved.](#)

[Private Network For SIS Licensees.](#)