

D8T

Track-Type Tractor



Engine

Engine Power – 1,600 rpm

SAE J1995 (Gross)	273 kW	366 hp
ISO 14396	269 kW	361 hp
ISO 14396 (DIN)	365 hp	

Engine Power – 1,900 rpm

ISO 9249/SAE J1349	242 kW	325 hp
ISO 9249/SAE J1349 (DIN)	328 hp	

Weights

Operating Weight

Standard	38 351 kg
LGP	36 763 kg

Shipping Weight

Standard	29 553 kg
LGP	30 506 kg

Productivity

Proven Cat® C15 ACERT™ engine gives you more horsepower and proven reliability. Get more work done in less time with a larger blade.*

Ease of Operation

An updated cab provides greater visibility and comfort to help your operators work more productively.

Cat Connect Technology

GRADE for Dozers technologies like Cat GRADE with Slope Assist and Cat AccuGrade™ help you get jobs done faster and more accurately.

Ease of Maintenance

The D8T features easy service access and a variety of optional features to help make maintenance even easier so you can get back to work faster.

*Compared to previous model D8T.



Contents

- Power and Performance.....3
- Operator Environment.....4
- Cat Connect Technology.....5
- Equipped for the Job6
- Waste Handler.....7
- Serviceability and Customer Support.....8
- Specifications.....9
- Standard Equipment.....13
- Optional Equipment.....14

The D8T dozer is engineered to be durable and reliable in the toughest working conditions. The latest generation bulldozer provides more horsepower and offers an updated cab to give operators even better visibility and comfort. Productivity is improved with the largest Semi-Universal blade in the size class to help you move up to 13 percent more material per pass. Cat Connect GRADE technology options help you get more work done in less time.

Power and Performance

Designed to get the job done

Productivity

- Cat C15 ACERT engine delivers more horsepower* with more than a decade of proven reliability in a wide range of working conditions.
- Move up to 13 percent more material per pass* with the largest standard Semi-Universal blade in the size class (10.3 m³).
- Traditional features like elevated sprocket, differential steering and planetary power shift transmission with high efficiency torque divider give you the power, durability and reliability you expect from a Cat D8.
- Auto Shift automatically down shifts to the most efficient gear based on load for fuel savings.



Responsive Hydraulics

Dedicated implement and steering pumps mean you can count on simultaneous blade response and steering performance. This gives you precision and maneuverability, especially beneficial for working in close quarters or land clearing. Field-proven system senses load and continuously adjusts implement hydraulic power for maximum efficiency.

Dual Tilt/Automated Blade Assist

Boost productivity up to 10 percent with optional Dual Tilt blade and Automated Blade Assist. Dual Tilt improves load control and allows the operator to optimize the blade pitch angle for better balance and productivity.

Automated Blade Assist is a semi-automatic dozer control function that increases operator efficiency by automating blade pitch.

**Compared to previous model D8T.*

Operator Environment

Comfort and productivity



Updated cab, with an Integrated Roll Over Protection Structure (ROPS) offers greater all around visibility to enhance safety and productivity. Quiet interior, with improved pressurization, helps keep dust out. Standard air suspension seat is fully adjustable.

New color Liquid Crystal Display (LCD) is glare resistant and easy to read day or night.

- Monitor machine operation.
- Access machine/implement settings menus.
- View machine diagnostics.
- Slope Assist control screen.
- Displays real-time machine slope and mainfall.
- Rear-camera-ready for added safety.

Implement and Steering Controls

- Electro-hydraulic controls reduce operator effort, improve precision and response, and enable Cat Connect GRADE technologies.
- Single handle control for all directional changes and gear selection. Change gears up or down with the touch of a button.
- Rotary dial controls engine throttle speed.
- Bi-directional control allows the operator to dial to preselect forward/reverse gears for reduced operator effort and improved efficiency.
- Implement Lock-Out prevents inadvertent operation of hydraulic attachments.





Cat Connect Technology

Helping you work smarter



GRADE for Dozers

Cat Connect GRADE technologies help you hit target grade faster and more accurately. Finish jobs in fewer passes, and with less operator effort, saving you time and helping you increase profit.

Cat Slope Indicate (■) displays real-time machine cross-slope and fore/aft orientation on the primary monitor, helping operators work more accurately on slopes.

Automatically maintain established blade position with **Cat GRADE with Slope Assist** (●). Finish jobs faster, with better surface quality and significantly less operator effort. Requires no additional hardware or software.

Versatile, scalable **Cat AccuGrade** (●) is a dealer-installed grade control system. Choice of Laser, Global Navigation Satellite System (GNSS) or Universal Total Station (UTS) so you get the right level of accuracy to match your job requirements.

(■) – Standard

(●) – Optional



LINK Technologies

LINK technologies provide wireless capability to machines enabling two-way transfer of information collected by on-board sensors, control modules, and other Cat Connect technologies using off-board apps, such as our VisionLink® software.

Product Link™*/VisionLink

Product Link takes the guesswork out of equipment management. Track location, hours, fuel usage, productivity, idle time, and diagnostic codes through the online VisionLink interface. Manage your fleet in real time so you can maximize efficiency, improve productivity, and lower operating costs.

**Not available in all areas. Please consult your Cat dealer for details.*

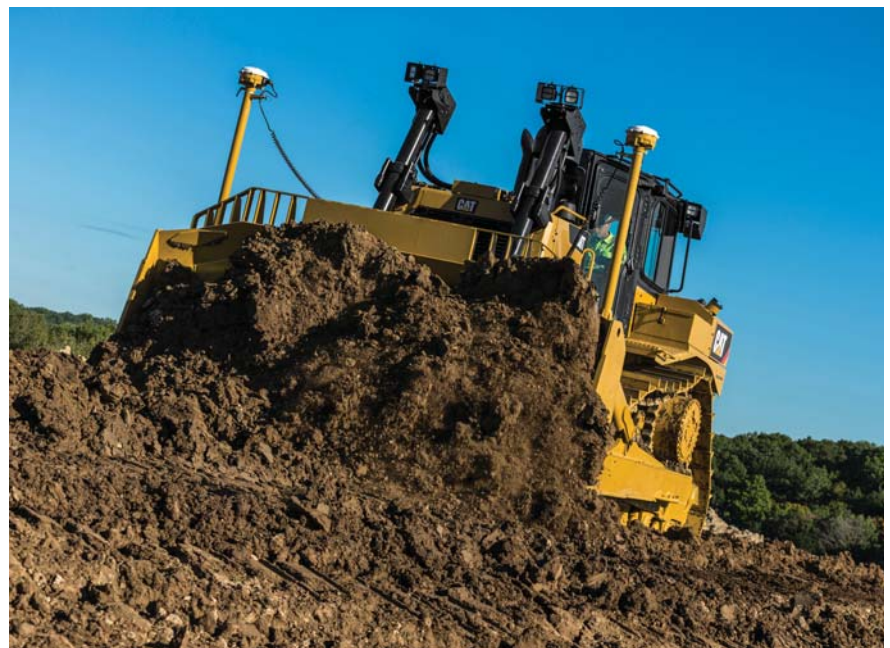

Equipped for the Job

Optimize your machine

Structures

The foundation of every Cat dozer is a rugged mainframe built to absorb high impact shock loads and twisting forces.

Castings add strength to the main case and equalizer bar saddle. The pivot shaft runs through the mainframe and connects the roller frame for independent oscillation. This provides strength, and allows the machine to better follow ground contours for maximum traction and operator comfort.

Bulldozers

Move up to 13 percent more material per pass with the largest standard Semi-Universal blade in the size class (10.3 m³). Blades are designed for durability with high tensile strength steel, strong box-section design, heavy moldboard construction and hardened bolt-on cutting edges/end bits. Standard deflector shields and optional rock guard help protect cylinders. Optional moldboard wear plate protects against high abrasive/impact applications.

Tag-link design mounts the blade closer to the machine for excellent maneuverability, balance and blade penetration.

Undercarriage

The elevated sprocket design helps protect major components from harsh impacts and provides a modular design for convenient service. A fully suspended undercarriage provides more ground contact, especially in hard, uneven terrain. A Low Ground Pressure (LGP) undercarriage is available for improved flotation and traction in soft underfoot conditions.

The exclusive Cat Positive Pin Retention system is designed for high-impact and high load applications, locking the link to the pin to ensure internal lubrication between track pin and bushing is maintained. Lifetime lubricated idlers and track/carrier rollers provide the ability to re-use internal components and rebuild or reshell components for reduced owning and operating costs.



Rear Implements

Single shank ripper depth and multi-shank adjustable parallelogram rippers are available. Single-Shank ripper depth can be adjusted from the seat using an optional pin puller. Or, outfit your dozer with a winch, drawbar or rear counterweight. Ask your Cat dealer for available options to suit your applications.



Waste Handler

Purpose-built for performance

D8T WH Waste Handler

Whether building or closing cells, pushing trash or spreading cover, the D8T WH is designed and built from the frame up to take on the unique challenges of landfill work.

- Specialized guarding, striker bars and seals help protect the machine from impact and airborne debris.
- Bottom and Final Drive guarding help prevent debris from wrapping around or damaging vital components.
- The cooling system is designed for high debris environments, with easy access for cleanout.
- Lights are mounted up and away from main debris area for protection, while still shining plenty of light on the work area.
- Specialized air handling features help deliver cleaner air to the machine and to the cab.
- Landfill blades and center-hole track shoes help you optimize your waste handler for the job.

Serviceability and Customer Support

When uptime counts



Like all Cat dozers, the D8T is designed with features like wide engine panel access doors to minimize maintenance and repair time. You can also outfit your dozer with a variety of service features to make maintenance even easier so you can get back to work faster:

- Cab-mounted air conditioning condenser (■) supports better system performance, improved engine cooling and serviceability.
- Ecology drains (●) help reduce spills during power train fluid changes.
- Fast fuel system (■) at ground level, with positive fuel shut-off, helps prevent fuel spillage/waste and speeds refueling for more uptime.
- High-speed oil change attachment (●) to help make servicing even faster.

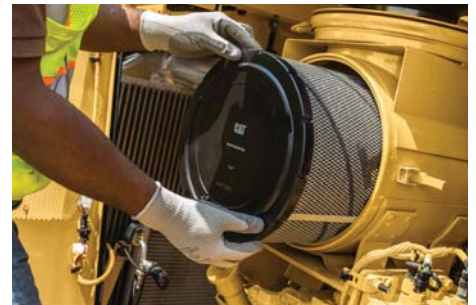

Renowned Cat Dealer Support

Knowledgeable Cat dealers have a global reputation for providing outstanding sales and service. When you need repairs, Cat dealers and our unmatched Caterpillar distribution network excel at getting you the right parts you need quickly.

Maximize your equipment investment with services like Customer Support Agreements, preventive maintenance programs and guaranteed maintenance contracts. Remanufactured parts offer a lower cost replacement option, and Certified Rebuild gives a “second life” for your machine. Cat dealers can even help you with operator training to help boost your profits. Contact your Cat dealer to learn more about available services best suited to your business.



■ – Standard
● – Optional

D8T Track-Type Tractor Specifications

Engine

Engine Model	Cat C15 ACERT	
Emissions	Meets Brazil MAR-1 emission standards, equivalent to U.S. EPA Tier 3/EU Stage IIIA, or optionally Tier 2/Stage II as required by region	
Engine Power – 1,600 rpm		
SAE J1995 (gross)	273 kW	366 hp
ISO 14396	269 kW	361 hp
ISO 14396 (DIN)	365 hp	
Engine Power – 1,900 rpm		
ISO 9249/SAE J1349	242 kW	325 hp
ISO 9249/SAE J1349 (DIN)	328 hp	
Bore	137 mm	
Stroke	172 mm	
Displacement	15.2 L	

- ISO 9249 is the power available at the flywheel when the engine is equipped with fan, air cleaner, muffler, and alternator.
- No derating required up to 3658 m altitude, beyond 3658 m automatic derating occurs.

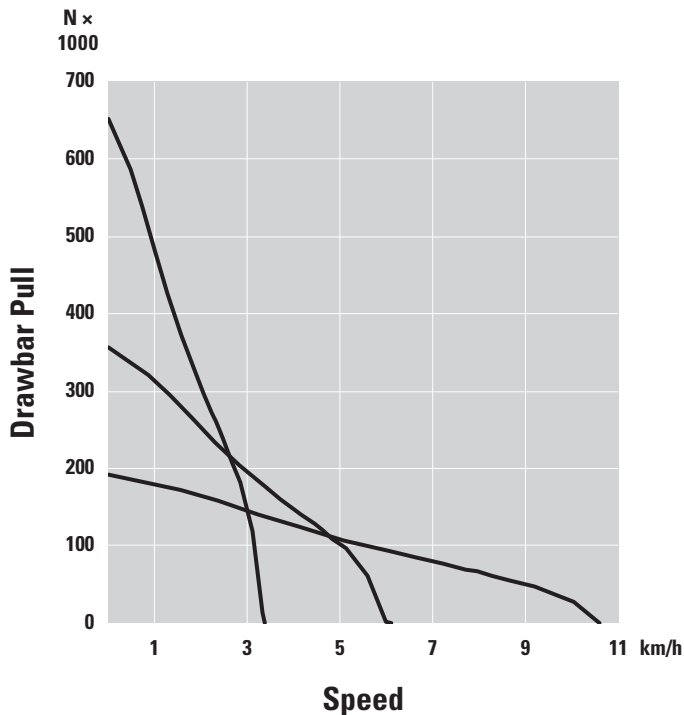

Service Refill Capacities

Fuel Tank	600 L
Cooling System	62 L
Engine Crankcase*	38 L
Power Train	155 L
Final Drives (each)	12.5 L
Roller Frames (each)	65 L
Pivot Shaft Compartment	40 L

*With oil filters.

Weights

Operating Weight	
Standard	38 351 kg
LGP	36 763 kg
Waste Handler	38 265 kg
LGP Waste Handler	40 483 kg
Shipping Weight	
Standard	29 553 kg
LGP	30 506 kg
Waste Handler	32 227 kg
LGP Waste Handler	34 269 kg

- Operating Weight – Standard: Includes hydraulic controls, blade, tilt cylinder, coolant, lubricants, 100% fuel, ROPS, FOPS cab, SU-Blade, Single-Shank Ripper, 610 mm Moderate Service shoes, and operator.
- Operating Weight – LGP: Includes hydraulic controls, blade, tilt cylinder, drawbar, coolant, lubricants, 100% fuel, ROPS, FOPS cab, SU-Blade, 965 mm Moderate Service shoes, and operator.
- Operating Weight – Waste: Includes hydraulic controls, tilt cylinder, striker box, coolant, lubricants, 100% fuel, ROPS, FOPS cab, SU- Waste Blade, 610 mm Moderate Service trapezoidal shoes for Standard/965 mm Moderate Service trapezoidal shoes for LGP, and operator.
- Shipping Weight: Includes coolant, lubricants, 20% fuel, ROPS, FOPS cab. For Standard includes 610 mm Moderate Service shoes; for LGP includes 965 mm Moderate Service shoes.
- Waste Handler Shipping Weight includes coolant, lubricants, 20% fuel, ROPS, FOPS cab, striker box. For Waste Handler includes 610 mm Moderate Service shoes; for LGP Waste Handler includes 965 mm Moderate Service shoes.

D8T Track-Type Tractor Specifications

Undercarriage – Standard

Shoe Type	Moderate service
Width of Shoe	610 mm
Shoes/Side	44
Grouser Height	78 mm
Pitch	216 mm
Ground Clearance	618 mm
Track Gauge	2082 mm
Length of Track on Ground	3207 mm
Ground Contact Area	3.9 m ²
Track Rollers/Side	8
Number of Carrier Rollers	1 per side (optional)
Ground Pressure (ISO 16754)	86.4 kPa/12.5 psi

- Positive Pin Retention Track.

Undercarriage – LGP

Shoe Type	Moderate service
Width of Shoe	965 mm
Shoes/Side	44
Grouser Height	78 mm
Pitch	216 mm
Ground Clearance	216 mm
Track Gauge	2337
Length of Track on Ground	3207 mm
Ground Contact Area	6.19 m ²
Track Rollers/Side	8
Number of Carrier Rollers	1 per side (optional)
Ground Pressure (ISO 16754)	52.3 kPa/7.6 psi

Hydraulic Controls

Pump Type	Piston-type, variable displacement
Pump Output (steering)	276 L/min
Pump Output (implement)	232 L/min
Tilt Cylinder Rod End Flow	130 L/min
Tilt Cylinder Head End Flow	170 L/min
Bulldozer Relief Valve Setting	24 100 kPa
Tilt Cylinder Relief Valve Setting	24 100 kPa
Ripper (lift) Relief Valve Setting	24 100 kPa
Ripper (pitch) Relief Valve Setting	24 100 kPa
Steering	39 200 kPa

- Steering Pump output measured at 2,300 rpm and 30 000 kPa.
- Implement Pump output measured at 1,850 rpm and 6895 kPa.
- Electro-hydraulic pilot valve assists operations of ripper and dozer controls. Standard hydraulic systems includes four valves.
- Complete system consists of pump, tank with filter, oil cooler, valves, lines, linkage and control levers.

Transmission

1 Forward	3.4 km/h
2 Forward	6.1 km/h
3 Forward	10.6 km/h
1 Reverse	4.5 km/h
2 Reverse	8.0 km/h
3 Reverse	14.2 km/h
1 Forward – Drawbar Pull (1,000)	650.7 N
2 Forward – Drawbar Pull (1,000)	356.9 N
3 Forward – Drawbar Pull (1,000)	191.8 N

D8T Track-Type Tractor Specifications

Blades

Type	8SU	8U	8A Angle and Straight	8SU LGP	8SU Landfill	LGP Landfill
Capacity (SAE J1265)	10.3 m ³	11.7 m ³	4.7 m ³	9.9 m ³	21.2 m ³	22.2 m ³
Width (over end bits)	4041 mm	4267 mm	4990 mm	4542 mm	4041 mm	4542 mm
Height	1750 mm	1740 mm	1174 mm	1612 mm	2538 mm	2427 mm
Digging Depth	578 mm	575 mm	628 mm	575 mm	578 mm	575 mm
Ground Clearance	1235 mm	618 mm	1308 mm	1228 mm	1235 mm	1228 mm
Maximum Tilt	883 mm	954 mm	729 mm	829 mm	883 mm	829 mm
Weight (without hydraulic controls)	4789 kg	5352 kg	5459 kg	4850 kg	5675 kg	5369 kg

Single-Shank, Adjustable Parallelogram Rippers

Number of Pockets	1
Added Length	1692 mm
Maximum Clearance Raised (under tip, pinned in bottom hole)	636 mm
Maximum Penetration (standard tip)	1130 mm
Maximum Penetration Force (shank vertical)	129.8 kN
Maximum Penetration Force with optional push block (1095 kg)	142.7 kN
Pry out Force	224.9 kN
Pry out Force with optional push block (1095 kg)	213.5 kN
Weight (without hydraulic controls)	4085 kg
Weight – Optional Push Block	1095 kg

Multi-Shank, Adjustable Parallelogram Rippers

Number of Pockets	3
Added Length	1598 mm
Overall Beam Width	2464 mm
Maximum Clearance Raised (under tip, pinned in bottom hole)	593 mm
Maximum Penetration (standard tip)	780 mm
Maximum Penetration Force (shank vertical)	124.2 kN
Pry out Force (multi-shank ripper with one tooth)	227.9 kN
Weight (one shank, without hydraulic controls)	4877 kg
Weight Additional Shank	332 kg

Standards

- ROPS (Rollover Protective Structure) offered by Caterpillar for the machine meets ROPS criteria ISO 3471:2008.
- FOPS (Falling Object Protective Structure) meets ISO 3449:2005 Level II.
- The declared dynamic operator sound pressure level is 80 dB(A) when “ISO 6396:2008” is used to measure the value for an enclosed cab. On machines equipped with the sound package, the declared dynamic operator sound pressure level is 78 dB(A) when “ISO 6396:2008” is used to measure the value for an enclosed cab. The measurements were conducted at 70% of the maximum engine cooling fan speed. The sound level may vary at different engine cooling fan speeds. The cab was properly installed and maintained.
- Hearing protection may be needed when the machine is operated with an open operator station for extended periods or in a noisy environment. Hearing protection may be needed when the machine is operated with a cab that is not properly maintained, or when the doors and windows are open for extended periods or in a noisy environment.
- The declared exterior sound power level is 117 dB(A) when the value is measured according to the dynamic test procedures and the conditions that are specified in “ISO 6395:2008.” On machines equipped with the sound package, the declared exterior sound power level is 113 dB(A) when the value is measured according to the dynamic test procedures and the conditions that are specified in “ISO 6395:2008.” The measurements were conducted at 70% of the maximum engine cooling fan speed. The sound level may vary at different engine cooling fan speeds.

D8T Track-Type Tractor Specifications

Dimensions

All dimensions are approximate.

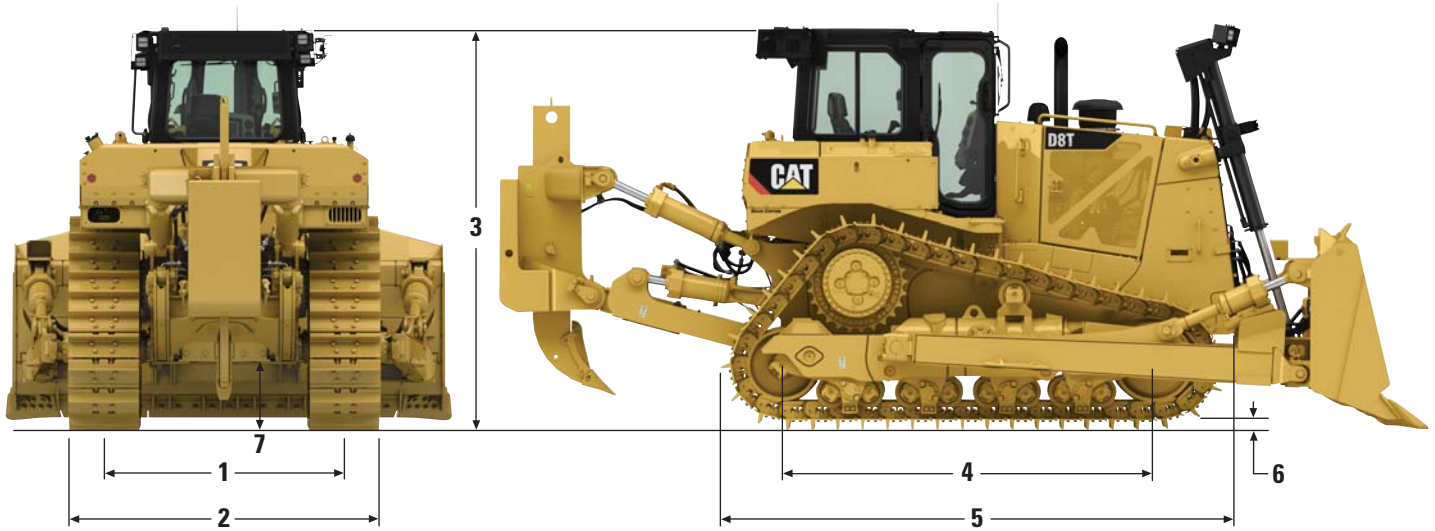

	Standard	Non-Suspended	LGP
1 Track Gauge	2083 mm	2083 mm	2337 mm
2 Width of Tractor			
Width without Trunnions (standard shoe)	2743 mm	2743 mm	3311 mm
Width over Trunnions	3057 mm	3057 mm	3656 mm
3 Height			
Top of Stack	3400 mm	3400 mm	3400 mm
ROPS/FOPS Cab	3488 mm	3488 mm	3488 mm
4 Length of Track on Ground	3207 mm	3258 mm	3207 mm
5 Overall Length of Basic Tractor	4647 mm	4647 mm	4647 mm
With the following attachments add:			
Ripper Single Shank	1519 mm	1519 mm	N/A
Ripper Multi-Shank	1613 mm	1613 mm	N/A
SU Blade	1844 mm	1844 mm	1844 mm
U Blade	2241 mm	2241 mm	N/A
A Blade (not angled)	2027 mm	2027 mm	N/A
A Blade (angled 25 degrees)	3068 mm	3068 mm	N/A
Drawbar	406 mm	406 mm	406 mm
6 Height of Grouser	78 mm	78 mm	78 mm
7 Ground Clearance	613 mm	606 mm	613 mm
Drawbar Height (center of clevis)	708 mm	701 mm	708 mm

Standard Equipment

Standard equipment may vary. Consult your Cat dealer for details.

POWER TRAIN

- Cat C15 ACERT diesel engine
 - Meets Brazil MAR-1 emission standards, equivalent to Tier 3/Stage IIIA, or optionally Tier 2/Stage II as required by region
- Radiator core, high performance aluminum bar plate
- Air cleaner, precleaner with strata tube dust ejector
- Air to air aftercooler (ATAAC)
- Extended life coolant
- Fan, reversing, hydraulically driven
- Final drives, 4-planet double reduction planetary
- Fuel priming pump
- Muffler with mitered stack
- Transmission powershift, 3F/3R speed
- Parking brake
- Prescreener
- Grill doors, louvered
- Torque divider
- Turbocharger
- Water separator

UNDERCARRIAGE

- Standard gauge 2083 mm
- Equalizer bar
- Guards, end track guiding
- Idlers, life time lubricated
- Track adjusters, hydraulic
- Track rollers, life time lubricated
- Track roller frames, suspended
- Sprocket rim segments, replaceable
- 610 mm Moderate Service Track, sealed and lubricated
 - Positive Pin Retention (PPR)
 - 44 section
- Two piece master links

ELECTRICAL

- Alarm, back-up
- Alternator
- Batteries, 4, 12V each, 24V system
- Lights
- Horn, forward warning
- Electric start, 24V

OPERATOR ENVIRONMENT

- Integrated ROPS/FOPS operator station
- Armrest, adjustable
- Decelerator pedal
- Differential steering tiller bar with dual-twist control
- Electronic monitoring system (EMS)
 - Hydraulic temperature
 - Power train temperature
 - Engine coolant temperature
 - Fuel level
 - Engine speed, tachometer
 - Service hour meter
 - System warning lamps
- Foot pads, dash
- Hydraulic controls, pilot operated with electronic deactivation switch
- Mirror, rearview
- Seat, adjustable contour suspension
- Seatbelt, retractable, 76 mm wide

OTHER STANDARD EQUIPMENT

- Engine enclosures and hood
- Ripper ready hydraulics
- Front pull device
- Guards, bottom
- Hydraulics
 - Load sensing dozer (lift/tilt) and ripper (lift/pitch)
- Independent steering and implement hydraulic pumps
- Instructions, international
- Mounting, lift cylinder
- Oil cooler, hydraulic
- Operation and Maintenance manual
 - Paper
- Parts book
 - CD ROM
- Product Link ready
- S·O·SSM sampling ports
 - Engine oil
 - Coolant
 - Power train oil
 - Hydraulic oil
- Vandalism protection
 - Provision for cap-locks for fluid compartments, engine enclosures and battery box

D8T Optional Equipment

Optional Equipment

Note: Some options available by special order only. Please consult your Cat dealer for details.

POWER TRAIN

- Exhaust wraps, thermal, waste handler

PRECLEANER

- Precleaner, with screen – dual stage
- Precleaner, turbine – single stage

FUEL LINES

- Fuel lines, B20 compliant

FUEL TANK FILLING SYSTEMS

- Fill system, fuel, fast fill

OIL CHANGE SYSTEM

- Oil change system, high speed

HYDRAULICS

- Dozer tilt hydraulics
- Hydraulics, dual tilt
- Rear attachment hydraulics
- Rear hydraulics, ripper (pilot)
- Rear hydraulics, ripper (electro-hydraulic)

FINAL DRIVE ARRANGEMENTS

- Final drives, LGP
- Final drives, LGP, guarded and sealed
- Final drives, cold weather
- Final drives, guarded and sealed

SPECIAL ARRANGEMENTS

- Waste Handling Arrangement

UNDERCARRIAGE

- Gauge arrangement
 - Standard
 - LGP (Low Ground Pressure)
 - Positive pin retention, suspended undercarriage
 - Basic, suspended
 - Suspended with guarded idler
 - Suspended with cold weather rollers and idlers
 - Non-suspended undercarriage arrangements
 - Basic, non-suspended
 - Basic, non-suspended
 - Non-suspended with guarded idlers
 - Carrier roller arrangement
 - Standard carrier rollers
 - Arctic carrier rollers – suspended undercarriage
- Track arrangements
 - Positive pin retention track (44 section)
 - 560 mm extreme service
 - 560 mm extreme service, trapezoidal
 - 610 mm moderate service
 - 610 mm extreme service
 - 660 mm moderate service
 - 660 mm extreme service
 - 710 mm moderate service
 - 610 mm extreme service, trapezoidal
 - 610 mm extreme service
 - 660 mm extreme service trapezoidal
 - 660 mm super extreme service, trapezoidal
 - 710 mm extreme service
 - 710 mm moderate service, trapezoidal
 - 710 mm extreme service, trapezoidal
 - 965 mm moderate service
 - 965 mm extreme service, trapezoidal
 - 965 mm extreme service

STARTERS, BATTERIES AND ALTERNATORS

- Alternator, standard (150 amp)
- Alternator, ducted (150 amp)
- Batteries, standard, 1,000 CCA
- Batteries, cold weather, 1,000 CCA
- Ether starting aid
- Engine coolant heater, 240V

ELECTRICAL

- Lighting groups*
- Lights, six halogen work lights
- Lights, premium, 10 LED lights
- Lights, sweeps, eight halogen lights

OPERATOR ENVIRONMENT

- Cab glass options
 - Glass, single pane
 - Glass, dual pane
 - Canopy (no glass)
- Air conditioning
 - Air conditioning (cab mounted)
 - Air conditioning (underhood)
 - No air conditioning (canopy only)
- Cab seat
 - Seat, heated and ventilated, cloth, air suspension
 - Seat, vinyl, air suspension
 - Seat, cloth, air suspension
 - Seat, vinyl
 - Seat, cloth
- Visibility arrangement
 - Rear vision camera
- Power supply
 - In cab – 12V and 24V
- Screens
 - Screen group – sun
 - Rear screen – cab
 - Rear screen – canopy
- Platform Options
 - Quick opening (high debris applications)
 - 5th percentile

*Lights for Rippers included in Ripper arrangements

(continued on next page)

Optional Equipment *(continued)*

Note: Some options available by special order only. Please consult your Cat dealer for details.

TECHNOLOGY PRODUCTS

- Machine Control
 - Electro-Hydraulics
 - Single Tilt Control for Slope Assist
 - Basic Dual Tilt Control
 - Machine Control, ARO (Single Tilt or dual tilt)
 - Pilot Hydraulics
 - Basic Single Tilt Control (pilot hydraulics)
 - Basic Dual Tilt Control (pilot hydraulics)
- Cat Connect Technology
 - Product Link
 - Product Link Elite – PLE641
 - Product Link – PL631
 - Product Link – PL641
 - No Product Link
 - Cat GRADE with Slope Assist
 - Cat AccuGrade (dealer installed)

GUARDS

- Bottom guards, standard
- Heavy duty, sealed
- Heavy duty, sealed, powered
- Heavy duty, sealed and sound suppressed
- Heavy duty, sealed with front counterweight
- Guard, fuel tank
- Guard, fan debris
- Guard, grill, debris
- Sweeps
- Striker bars – front

WORK TOOLS

- Rear attachments
 - Drawbar, rear (rigid)
 - Rippers
 - Single shank
 - Single shank with pin puller
 - Single shank with pin puller and striker bars
 - Single shank with push block
 - Single shank with striker bars
 - Multi-shank
 - Multi-shank with striker bars
 - Ripper tooth
 - Multi-shank
 - Single shank
 - Shank, deep
 - Hitch
 - Rear counterweight and hitch
 - Striker bar, storage box, drawbar and hitch
 - Additional rear counterweight

FLUIDS

- Lubricants/oils
- Lubricant group – high ambient
- Lubricant group – arctic

COOLANT

- Standard engine coolant (–37° C)
- Arctic engine coolant (–50° C)

SERVICE PACKAGE

- Ecology drains – transmission and torque converter

SEALING

- Seals, sound suppression
- Seals, Waste

BULLDOZER INSTALLATION PACKAGES

- 8SU/U single tilt cylinder
- 8SU/U single tilt cylinder, guarded lines
- 8A blade
- 8 LGP dual tilt cylinders, guarded lines
- 8 LGP single tilt cylinder
- 8 LGP single tilt cylinder, guarded lines
- 8SU/U dual tilt cylinders, guarded lines

PUSH ARM GROUP

- Single tilt standard
- Dual tilt standard
- Extreme service

BLADE OPTIONS

- 8SU
- 8SU, Landfill
- 8U
- 8U, Landfill
- 8A
- 8SU LGP
- 8SU LGP, Landfill
- 8SU
- 8SU, Landfill
- 8U
- 8U, Landfill
- 8SU LGP
- 8SU LGP, Landfill
- Select blades also available with Rock Guard, Rock Guard and Wear Plate or Push Plate



For more complete information on Cat products, dealer services, and industry solutions, visit us on the web at www.cat.com

AEHQ8020 (03-2017)
(South America, Turkey)

© 2017 Caterpillar
All rights reserved

Materials and specifications are subject to change without notice. Featured machines in photos may include additional equipment. See your Cat dealer for available options.

CAT, CATERPILLAR, SAFETY.CAT.COM, their respective logos, "Caterpillar Yellow" and the "Power Edge" trade dress, as well as corporate and product identity used herein, are trademarks of Caterpillar and may not be used without permission.

VisionLink is a trademark of Trimble Navigation Limited, registered in the United States and in other countries.

