

Operation and Maintenance Manual

2506D-E15TA Industrial Engine

PK5 (Engine)



Important Safety Information

Most accidents that involve product operation, maintenance and repair are caused by failure to observe basic safety rules or precautions. An accident can often be avoided by recognizing potentially hazardous situations before an accident occurs. A person must be alert to potential hazards. This person should also have the necessary training, skills and tools to perform these functions correctly.

Incorrect operation, lubrication, maintenance or repair of this product can be dangerous and could result in injury or death.

Do not operate or perform any lubrication, maintenance or repair on this product, until you have read and understood the operation, lubrication, maintenance and repair information.

Safety precautions and warnings are provided in this manual and on the product. If these hazard warnings are not heeded, bodily injury or death could occur to you or to other persons.

The hazards are identified by the "Safety Alert Symbol" and followed by a "Signal Word" such as "DANGER", "WARNING" or "CAUTION". The Safety Alert "WARNING" label is shown below.



The meaning of this safety alert symbol is as follows:

Attention! Become Alert! Your Safety is Involved.

The message that appears under the warning explains the hazard and can be either written or pictorially presented.

Operations that may cause product damage are identified by "NOTICE" labels on the product and in this publication.

Perkins cannot anticipate every possible circumstance that might involve a potential hazard. The warnings in this publication and on the product are, therefore, not all inclusive. You must not use this product in any manner different from that considered by this manual without first satisfying yourself that you have considered all safety rules and precautions applicable to the operation of the product in the location of use, including site-specific rules and precautions applicable to the worksite. If a tool, procedure, work method or operating technique that is not specifically recommended by Perkins is used, you must satisfy yourself that it is safe for you and for others. You should also ensure that you are authorized to perform this work, and that the product will not be damaged or become unsafe by the operation, lubrication, maintenance or repair procedures that you intend to use.

The information, specifications, and illustrations in this publication are on the basis of information that was available at the time that the publication was written. The specifications, torques, pressures, measurements, adjustments, illustrations, and other items can change at any time. These changes can affect the service that is given to the product. Obtain the complete and most current information before you start any job. Perkins dealers or Perkins distributors have the most current information available.



When replacement parts are required for this product Perkins recommends using Perkins replacement parts.

Failure to heed this warning can lead to premature failures, product damage, personal injury or death.

In the United States, the maintenance, replacement, or repair of the emission control devices and systems may be performed by any repair establishment or individual of the owner's choosing.

Table of Contents

Foreword 4

Safety Section

Safety Messages 6

General Hazard Information 8

Burn Prevention 11

Fire Prevention and Explosion Prevention 12

Crushing Prevention and Cutting Prevention .. 14

Mounting and Dismounting 14

Before Starting Engine 14

Engine Starting 15

Engine Stopping 15

Electrical System 15

Engine Electronics 16

Product Information Section

General Information 17

Product Identification Information 21

Operation Section

Lifting and Storage 22

Features and Controls 26

Engine Diagnostics 30

Engine Starting 32

Engine Operation 36

Cold Weather Operation 38

Engine Stopping 40

Maintenance Section

Refill Capacities 41

Maintenance Recommendations 57

Maintenance Interval Schedule 60

Index Section

Index 88

Foreword

California Proposition 65 Warning

Diesel engine exhaust and some of its constituents are known to the State of California to cause cancer, birth defects, and other reproductive harm.



WARNING – This product can expose you to chemicals including ethylene glycol, which is known to the State of California to cause birth defects or other reproductive harm. For more information go to:

www.P65Warnings.ca.gov

Do not ingest this chemical. Wash hands after handling to avoid incidental ingestion.



WARNING – This product can expose you to chemicals including lead and lead compounds, which are known to the State of California to cause cancer, birth defects, or other reproductive harm. For more information go to:

www.P65Warnings.ca.gov

Wash hands after handling components that may contain lead.

Literature Information

This manual contains safety, operation instructions, lubrication, and maintenance information. This manual should be stored in or near the engine area in a literature holder or literature storage area. Read, study, and keep the manual with the literature and engine information.

English is the primary language for all Perkins publications. The English used facilitates translation and consistency.

Some photographs or illustrations in this manual show details or attachments that may be different from your engine. Guards and covers may have been removed for illustrative purposes. Continuing improvement and advancement of product design may have caused changes to your engine which are not included in this manual. Whenever a question arises regarding your engine, or this manual, please consult with your Perkins dealer or your Perkins distributor for the latest available information.

Safety

This safety section lists basic safety precautions. In addition, this section identifies hazardous, warning situations. Read and understand the basic precautions listed in the safety section before operating or performing lubrication, maintenance, and repair on this product.

Operation

Operating techniques outlined in this manual are basic. The operating techniques assist with developing the skills and techniques required to operate the engine more efficiently and economically. Skill and techniques develop as the operator gains knowledge of the engine and the capabilities of the engine.

The operation section is a reference for operators. Photographs and illustrations guide the operator through procedures of inspecting, starting, operating, and stopping the engine. This section also includes a discussion of electronic diagnostic information.

Maintenance

The maintenance section is a guide to engine care. The illustrated, step-by-step instructions are grouped by service hours and/or calendar time maintenance intervals. Items in the maintenance schedule are referenced to detailed instructions that follow.

Recommended service should be performed at the appropriate intervals as indicated in the Maintenance Interval Schedule. The actual operating environment of the engine also governs the Maintenance Interval Schedule. Therefore, under severe, dusty, wet, or freezing cold operating conditions, more frequent lubrication, and maintenance than is specified in the Maintenance Interval Schedule may be necessary.

The maintenance schedule items are organized for a preventive maintenance management program. If the preventive maintenance program is followed, a periodic tune-up is not required. The implementation of a preventive maintenance management program should minimize operating costs through cost avoidances resulting from reductions in unscheduled downtime and failures.

Maintenance Intervals

Perform maintenance on items at multiples of the original requirement. Each level and/or individual items in each level should be shifted ahead or back depending upon your specific maintenance practices, operation, and application. Perkins recommends that the maintenance schedules be reproduced and displayed near the engine as a convenient reminder. Perkins also recommends that a maintenance record be maintained as part of the permanent record of the engine.

Your authorized Perkins dealer or your Perkins distributor can assist you in adjusting your maintenance schedule to meet the needs of your operating environment.

Overhaul

Major engine overhaul details are not covered in the Operation and Maintenance Manual except for the interval and the maintenance items in that interval. Major repairs are best left to trained personnel or an authorized Perkins distributor or dealer. Your Perkins dealer or your Perkins distributor offers various options regarding overhaul programs. If you experience a major engine failure, there are also numerous after failure overhaul options available. Consult with your Perkins dealer or your Perkins distributor for information regarding these options.

Safety Section

i06918984

Safety Messages

There may be several specific safety messages on your engine. The exact location and a description of the safety messages are reviewed in this section. Become familiar with all safety messages.

Ensure that all the safety messages are legible. Clean the safety messages or replace the safety messages if the words cannot be read or if the illustrations are not visible. Use a cloth, water, and soap to clean the safety messages. Do not use solvents, gasoline, or other harsh chemicals. Solvents, gasoline, or harsh chemicals could loosen the adhesive that secures the safety messages. The safety messages that are loosened could drop off the engine.

Replace any safety message that is damaged or missing. If a safety message is attached to a part of the engine that is replaced, install a new safety message on the replacement part. Your Perkins distributor can provide new safety messages.

2506D-E15TA Safety Label Positions

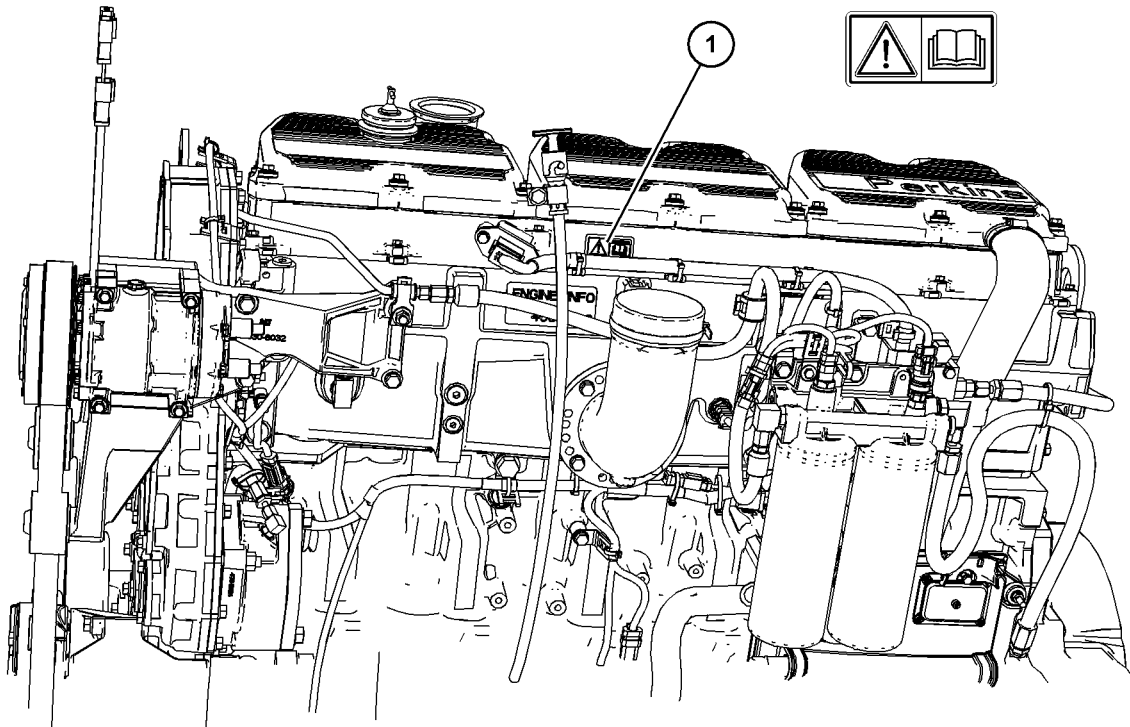

Illustration 1

Typical example

g06167616

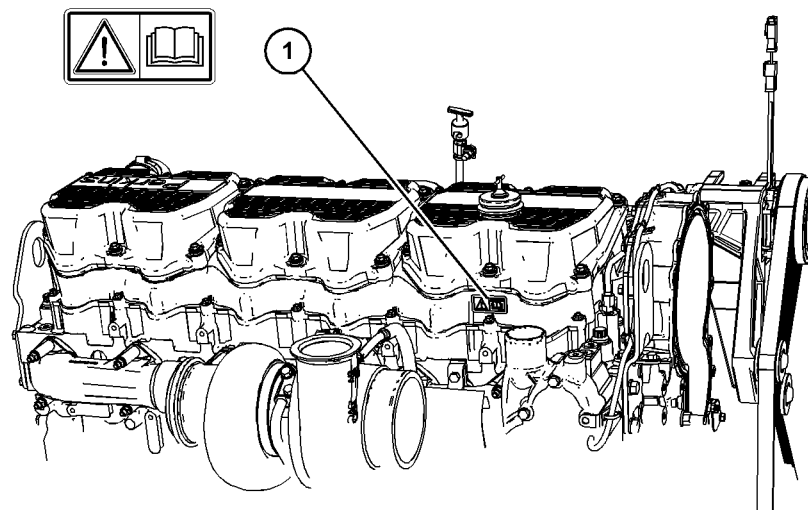

Illustration 2
Typical example

g06167638

Universal Warning (1)



Illustration 3 g01370904

One safety message is on the left side of the engine.
One safety message is on the right side of the engine.

WARNING

Do not operate or work on this equipment unless you have read and understand the instructions and warnings in the Operation and Maintenance Manuals. Failure to follow the instructions or heed the warnings could result in serious injury or death.

i08315176

General Hazard Information

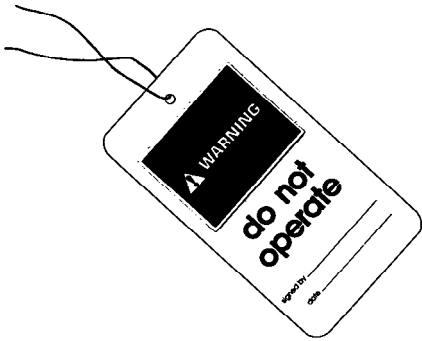

Illustration 4

g00104545

Attach a “Do Not Operate” warning tag or a similar warning tag to the start switch or to the controls before the engine is serviced or before the engine is repaired. Attach the warning tags to the engine and to each operator control station. When appropriate, disconnect the starting controls.

Do not allow unauthorized personnel on the engine, or around the engine when the engine is being serviced.

- Tampering with the engine installation or tampering with the OEM supplied wiring can be dangerous. Personal injury, death and/or engine damage could result.
 - Vent the engine exhaust to the outside when the engine is operated in an enclosed area.
 - If the engine is not running, do not release the secondary brake or the parking brake systems unless the vehicle is blocked or unless the vehicle is restrained.
 - Wear a hard hat, protective glasses, and other protective equipment, as required.
 - When work is performed around an engine that is operating, wear protective devices for ears to help prevent damage to hearing.
 - Do not wear loose clothing or jewelry that can snag on controls or on other parts of the engine.
 - Ensure that all protective guards and all covers are secured in place on the engine.
 - Never put maintenance fluids into glass containers. Glass containers can break.
 - Use all cleaning solutions with care.
 - Report all necessary repairs.
- Unless other instructions are provided, perform the maintenance under the following conditions:
- The engine is stopped. Ensure that the engine cannot be started.
 - The protective locks or the controls are in the applied position.
 - Engage the secondary brakes or parking brakes.
 - Block the vehicle or restrain the vehicle before maintenance or repairs are performed.
 - Disconnect the batteries when maintenance is performed or when the electrical system is serviced. Disconnect the battery ground leads. Tape the leads to help prevent sparks. If equipped, allow the diesel exhaust fluid to be purged before disconnecting the battery.
 - If equipped, disconnect the connectors for the unit injectors that are located on the valve cover base. This action will help prevent personal injury from the high voltage to the unit injectors. Do not come in contact with the unit injector terminals while the engine is operating.
 - Do not attempt any repairs or any adjustments to the engine while the engine is operating.
 - Do not attempt any repairs that are not understood. Use the proper tools. Replace any equipment that is damaged or repair the equipment.
 - For initial start-up of a new engine or for starting an engine that has been serviced, make provisions to stop the engine if an overspeed occurs. The stopping of the engine may be accomplished by shutting off the fuel supply and/or the air supply to the engine. Ensure that only the fuel supply line is shut off. Ensure that the fuel return line is open.
 - Start the engine from the operators station (cab). Never short across the starting motor terminals or the batteries. This action could bypass the engine neutral start system and/or the electrical system could be damaged.

Engine exhaust contains products of combustion which may be harmful to your health. Always start the engine and operate the engine in a well-ventilated area. If the engine is in an enclosed area, vent the engine exhaust to the outside.

Cautiously remove the following parts. To help prevent spraying or splashing of pressurized fluids, hold a rag over the part that is being removed.

- Filler caps
- Grease fittings
- Pressure taps
- Breathers
- Drain plugs

Use caution when cover plates are removed. Gradually loosen, but do not remove the last two bolts or nuts that are located at opposite ends of the cover plate or the device. Before removing the last two bolts or nuts, pry the cover loose to relieve any spring pressure or other pressure.

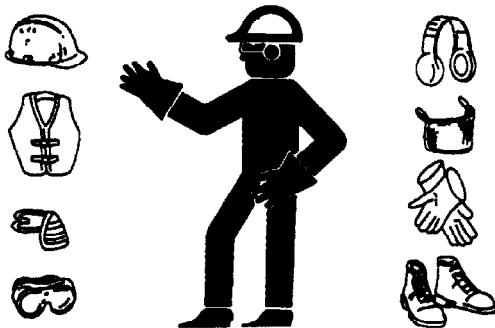

Illustration 5

g00702020

- Wear a hard hat, protective glasses, and other protective equipment, as required.
- When work is performed around an engine that is operating, wear protective devices for ears to help prevent damage to hearing.
- Do not wear loose clothing or jewelry that can snag on controls or on other parts of the engine.
- Ensure that all protective guards and all covers are secured in place on the engine.
- Never put maintenance fluids into glass containers. Glass containers can break.
- Use all cleaning solutions with care.
- Report all necessary repairs.

Unless other instructions are provided, perform the maintenance under the following conditions:

- The engine is stopped. Ensure that the engine cannot be started.
- Disconnect the batteries when maintenance is performed or when the electrical system is serviced. Disconnect the battery ground leads. Tape the leads to help prevent sparks.
- Do not attempt any repairs that are not understood. Use the proper tools. Replace any equipment that is damaged or repair the equipment.

Pressurized Air and Water

Pressurized air and/or water can cause debris and/or hot water to be blown out. This action could result in personal injury.

When pressurized air and/or pressurized water is used for cleaning, wear protective clothing, protective shoes, and eye protection. Eye protection includes goggles or a protective face shield.

The maximum air pressure for cleaning purposes must be below 205 kPa (30 psi). The maximum water pressure for cleaning purposes must be below 275 kPa (40 psi).

Fluid Penetration

Pressure can be trapped in the hydraulic circuit long after the engine has been stopped. The pressure can cause hydraulic fluid or items such as pipe plugs to escape rapidly if the pressure is not relieved correctly.

Do not remove any hydraulic components or parts until pressure has been relieved or personal injury may occur. Do not disassemble any hydraulic components or parts until pressure has been relieved or personal injury may occur. Refer to the OEM information for any procedures that are required to relieve the hydraulic pressure.

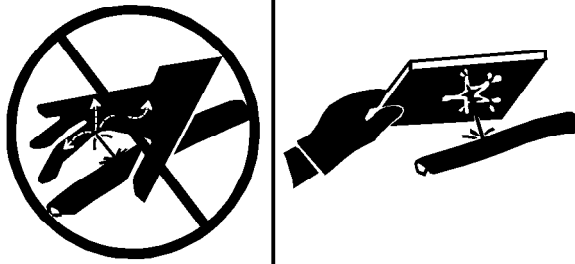

Illustration 6

g00687600

Always use a board or cardboard when you check for a leak. Leaking fluid that is under pressure can penetrate body tissue. Fluid penetration can cause serious injury and possible death. A pin hole leak can cause severe injury. If fluid is injected into your skin, you must get treatment immediately. Seek treatment from a doctor that is familiar with this type of injury.

Containing Fluid Spillage

Care must be taken to ensure that fluids are contained during performance of inspection, maintenance, testing, adjusting, and repair of the product. Be prepared to collect the fluid with suitable containers before opening any compartment or disassembling any component containing fluids.

Dispose of all fluids according to local regulations and mandates.

Static Electricity Hazard when Fueling with Ultra-low Sulfur Diesel Fuel

The removal of sulfur and other compounds in ultra-low sulfur diesel fuel (ULSD fuel) decreases the conductivity of ULSD and increases the ability of ULSD to store static charge. Refineries may have treated the fuel with a static dissipating additive. Many factors can reduce the effectiveness of the additive over time. Static charges can build up in ULSD fuel while the fuel is flowing through fuel delivery systems. Static electricity discharge when combustible vapors are present could result in a fire or explosion. Ensure that the entire system used to refuel your machine (fuel supply tank, transfer pump, transfer hose, nozzle, and others) is properly grounded and bonded. Consult with your fuel or fuel system supplier to ensure that the delivery system complies with fueling standards for proper grounding and bonding.

WARNING

Avoid static electricity risk when fueling. Ultra-low sulfur diesel fuel (ULSD fuel) poses a greater static ignition hazard than earlier diesel formulations with a higher sulfur contents. Avoid death or serious injury from fire or explosion. Consult with your fuel or fuel system supplier to ensure the delivery system is in compliance with fueling standards for proper grounding and bonding practices.

Inhalation

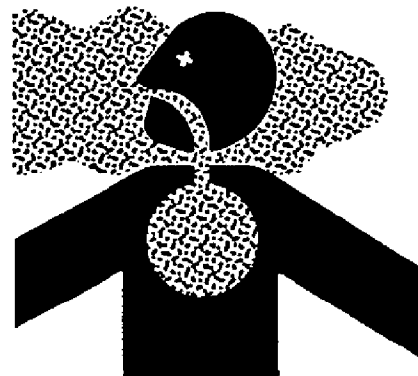

Illustration 7

g00702022

Exhaust

Use caution. Exhaust fumes can be hazardous to health. If you operate the equipment in an enclosed area, adequate ventilation is necessary.

Hexavalent Chromium

Perkins equipment and replacement parts comply with applicable regulations and requirements where originally sold. Perkins recommends the use of only genuine Perkins replacement parts.

Hexavalent chromium has occasionally been detected on exhaust and heat shield systems on Perkins engines. Although laboratory testing is the only accurate way to know if hexavalent chromium is, in fact, present, the presence of a yellow deposit in areas of high heat (for example, exhaust system components or exhaust insulation) may be an indication of the presence of hexavalent chromium.

Use caution if you suspect the presence of hexavalent chromium. Avoid skin contact when handling items that you suspect may contain hexavalent chromium, and avoid inhalation of any dust in the suspect area. Inhalation of, or skin contact with, hexavalent chromium dust may be hazardous to your health.

If such yellow deposits are found on the engine, engine component parts, or associated equipment or packages, Perkins recommends following local health and safety regulations and guidelines, utilizing good hygiene, and adhering to safe work practices when handling the equipment or parts. Perkins also recommends the following:

- Wear appropriate Personal Protective Equipment (PPE)
- Wash your hands and face with soap and water prior to eating, drinking, or smoking, and also during rest room breaks, to prevent ingestion of any yellow powder
- Never use compressed air for cleaning areas suspected of containing hexavalent chromium
- Avoid brushing, grinding, or cutting materials suspected of containing hexavalent chromium
- Obey environmental regulations for the disposal of all materials that may contain or have come into contact with hexavalent chromium
- Stay away from areas that might have hexavalent chromium particles in the air.

Asbestos Information

Perkins equipment and replacement parts that are shipped from Perkins engine company limited are asbestos free. Perkins recommends the use of only genuine Perkins replacement parts. Use the following guidelines when you handle any replacement parts that contain asbestos or when you handle asbestos debris.

Use caution. Avoid inhaling dust that might be generated when you handle components that contain asbestos fibers. Inhaling this dust can be hazardous to your health. The components that may contain asbestos fibers are brake pads, brake bands, lining material, clutch plates, and some gaskets. The asbestos that is used in these components is usually bound in a resin or sealed in some way. Normal handling is not hazardous unless airborne dust that contains asbestos is generated.

If dust that may contain asbestos is present, there are several guidelines that should be followed:

- Never use compressed air for cleaning.
- Avoid brushing materials that contain asbestos.
- Avoid grinding materials that contain asbestos.
- Use a wet method to clean up asbestos materials.
- A vacuum cleaner that is equipped with a high efficiency particulate air filter (HEPA) can also be used.

- Use exhaust ventilation on permanent machining jobs.
- Wear an approved respirator if there is no other way to control the dust.
- Comply with applicable rules and regulations for the work place. In the United States, use Occupational Safety and Health Administration (OSHA) requirements. These OSHA requirements can be found in "29 CFR 1910.1001".
- Obey environmental regulations for the disposal of asbestos.
- Stay away from areas that might have asbestos particles in the air.

Dispose of Waste Properly

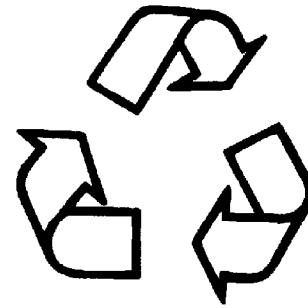

Illustration 8

g00706404

Improperly disposing of waste can threaten the environment. Potentially harmful fluids should be disposed of in accordance with local regulations.

Always use leakproof containers when you drain fluids. Do not pour waste onto the ground, down a drain, or into any source of water.

i06214247

Burn Prevention

Coolant

When the engine is at operating temperature, the engine coolant is hot. The coolant is also under pressure. The radiator and all lines to the heaters or to the engine contain hot coolant. Any contact with hot coolant or with steam can cause severe burns. Allow cooling system components to cool before the cooling system is drained.

Safety Section
Fire Prevention and Explosion Prevention

Check that the coolant level after the engine has stopped and the engine has been allowed to cool. Ensure that the filler cap is cool before removing the filler cap. The filler cap must be cool enough to touch with a bare hand. Remove the filler cap slowly in order to relieve pressure.

Cooling system conditioner contains alkali. Alkali can cause personal injury. Do not allow alkali to contact the skin, the eyes, or the mouth.

Oils

Skin may be irritated following repeated or prolonged exposure to mineral and synthetic base oils. Refer to your suppliers Material Safety Data Sheets for detailed information. Hot oil and lubricating components can cause personal injury. Do not allow hot oil to contact the skin. Appropriate personal protective equipment should be used.

Diesel Fuel

Diesel may be irritating to the eyes, respiratory system, and skin. Prolonged exposure to diesel may cause various skin conditions. Appropriate personal protective equipment should be used. Refer to supplier Material safety Data sheets for detailed information.

Batteries

The liquid in a battery is an electrolyte. Electrolyte is an acid that can cause personal injury. Do not allow electrolyte to contact the skin or the eyes.

Do not smoke while checking the battery electrolyte levels. Batteries give off flammable fumes which can explode.

Always wear protective glasses when you work with batteries. Wash hands after touching batteries. The use of gloves is recommended.

i06214251

Fire Prevention and Explosion Prevention



Illustration 9

g00704000

All fuels, most lubricants, and some coolant mixtures are flammable.

Flammable fluids that are leaking or spilled onto hot surfaces or onto electrical components can cause a fire. Fire may cause personal injury and property damage.

After the emergency stop button is operated, ensure that you allow 15 minutes, before the engine covers are removed.

Determine whether the engine will be operated in an environment that allows combustible gases to be drawn into the air inlet system. These gases could cause the engine to overspeed. Personal injury, property damage, or engine damage could result.

If the application involves the presence of combustible gases, consult your Perkins dealer and/or your Perkins distributor for additional information about suitable protection devices.

Remove all flammable combustible materials or conductive materials such as fuel, oil, and debris from the engine. Do not allow any flammable combustible materials or conductive materials to accumulate on the engine.

Store fuels and lubricants in correctly marked containers away from unauthorized persons. Store oily rags and any flammable materials in protective containers. Do not smoke in areas that are used for storing flammable materials.

Do not expose the engine to any flame.

Exhaust shields (if equipped) protect hot exhaust components from oil or fuel spray in case of a line, a tube, or a seal failure. Exhaust shields must be installed correctly.

Do not weld on lines or tanks that contain flammable fluids. Do not flame cut lines or tanks that contain flammable fluid. Clean any such lines or tanks thoroughly with a nonflammable solvent prior to welding or flame cutting.

Wiring must be kept in good condition. Ensure that all electrical wires are correctly installed and securely attached. Check all electrical wires daily. Repair any wires that are loose or frayed before you operate the engine. Clean all electrical connections and tighten all electrical connections.

Eliminate all wiring that is unattached or unnecessary. Do not use any wires or cables that are smaller than the recommended gauge. Do not bypass any fuses and/or circuit breakers.

Arcing or sparking could cause a fire. Secure connections, recommended wiring, and correctly maintained battery cables will help to prevent arcing or sparking.

Ensure that the engine is stopped. Inspect all lines and hoses for wear or for deterioration. Ensure that the hoses are correctly routed. The lines and hoses must have adequate support and secure clamps.

Oil filters and fuel filters must be installed correctly. The filter housings must be tightened to the correct torque. Refer to the Disassembly and Assembly manual for more information.

Avoid static electricity risk when fueling. Ultra-low Sulfur Diesel fuel (ULSD fuel) poses a greater static ignition hazard than earlier diesel formulations with a higher sulfur content. Avoid death or serious injury from fire or explosion. Consult your fuel or fuel system supplier to ensure that the delivery system is in compliance with fueling standards for proper grounding and bonding practices.

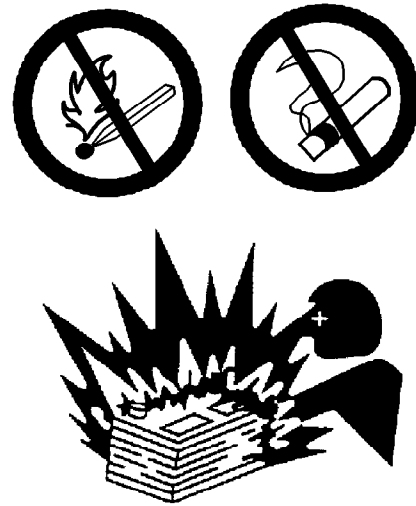

Illustration 11

g00704135

Gases from a battery can explode. Keep any open flames or sparks away from the top of a battery. Do not smoke in battery charging areas.

Never check the battery charge by placing a metal object across the terminal posts. Use a voltmeter or a hydrometer.

Incorrect jumper cable connections can cause an explosion that can result in injury. Refer to the Operation Section of this manual for specific instructions.

Do not charge a frozen battery. A frozen battery may cause an explosion.

The batteries must be kept clean. The covers (if equipped) must be kept on the cells. Use the recommended cables, connections, and battery box covers when the engine is operated.



Illustration 10

g00704059

Use caution when you are refueling an engine. Do not smoke while you are refueling an engine. Do not refuel an engine near open flames or sparks. Always stop the engine before refueling.

Fire Extinguisher

Make sure that a fire extinguisher is available. Be familiar with the operation of the fire extinguisher. Inspect the fire extinguisher and service the fire extinguisher regularly. Obey the recommendations on the instruction plate.

Ether

Ether is flammable and poisonous.

Do not smoke while you are replacing an ether cylinder or while you are using an ether spray.

Do not store ether cylinders in living areas or in the engine compartment. Do not store ether cylinders in direct sunlight or in temperatures above 49° C (120° F). Keep ether cylinders away from open flames or sparks.

Lines, Tubes, and Hoses

Do not bend high-pressure lines. Do not strike high-pressure lines. Do not install any lines that are damaged.

Leaks can cause fires. Consult your Perkins dealer or your Perkins distributor for replacement parts.

Replace the parts if any of the following conditions are present:

- End fittings are damaged or leaking.
- Outer coverings are chafed or cut.
- Wires are exposed.
- Outer coverings are ballooning.
- Flexible parts of the hoses are kinked.
- Outer covers have embedded armoring.
- End fittings are displaced.

Make sure that all clamps, guards, and heat shields are installed correctly. During engine operation, correct installation will help to prevent vibration, rubbing against other parts, and excessive heat.

i06214255

Crushing Prevention and Cutting Prevention

Support the component correctly when work beneath the component is performed.

Unless other maintenance instructions are provided, never attempt adjustments while the engine is running.

Stay clear of all rotating parts and of all moving parts. Leave the guards in place until maintenance is performed. After the maintenance is performed, reinstall the guards.

Keep objects away from moving fan blades. The fan blades will throw objects or cut objects.

When objects are struck, wear protective glasses in order to avoid injury to the eyes.

Chips or other debris may fly off objects when objects are struck. Before objects are struck, ensure that no one will be injured by flying debris.

i06214256

Mounting and Dismounting

Do not climb on the engine or the radiator. The engine and radiator have not been designed with mounting or dismounting locations.

Refer to the OEM for the location of foot and hand holds for your specific application.

i06214257

Before Starting Engine

NOTICE

For initial start-up of a new or rebuilt engine, and for start-up of an engine that has been serviced, make provision to shut the engine off should an overspeed occur. This may be accomplished by shutting off the air and/or fuel supply to the engine.

WARNING

Engine exhaust contains products of combustion which may be harmful to your health. Always start and operate the engine in a well ventilated area and, if in an enclosed area, vent the exhaust to the outside.

Inspect the engine for potential hazards.

Do not start the engine or move any of the controls if there is a "DO NOT OPERATE" warning tag or similar warning tag attached to the start switch or the controls.

Before starting the engine, ensure that no one is on, underneath, or close to the engine. Ensure that the area is free of personnel.

If equipped, ensure that the lighting system for the engine is suitable for the conditions. Ensure that all lights work properly, if equipped.

All protective guards and all protective covers must be installed if the engine must be started in order to perform service procedures. To help prevent an accident that is caused by parts in rotation, work around the parts carefully.

Do not start an engine when the governor linkage is disconnected.

Do not bypass the automatic shutoff circuits. Do not disable the automatic shutoff circuits. The circuits are provided in order to help prevent personal injury. The circuits are also provided in order to help prevent engine damage.

i06214258

Engine Starting

WARNING

Do not use aerosol types of starting aids such as ether. Such use could result in an explosion and personal injury.

If a warning tag is attached to the engine start switch or to the controls, DO NOT start the engine or move the controls. Consult with the person that attached the warning tag before the engine is started.

All protective guards and all protective covers must be installed if the engine must be started in order to perform service procedures. To help prevent an accident that is caused by parts in rotation, work around the parts carefully.

Start the engine from the operator compartment or from the engine start switch.

Always start the engine according to the procedure that is described in the Operation and Maintenance Manual, “Engine Starting” topic in the Operation Section. Knowing the correct procedure will help to prevent major damage to the engine components. Knowing the procedure will also help to prevent personal injury.

To ensure that the jacket water heater (if equipped) is working correctly, check the water temperature gauge and/or the oil temperature gauge during the heater operation.

Engine exhaust contains products of combustion which can be harmful to your health. Always start the engine and operate the engine in a ventilated area. If the engine is started in an enclosed area, vent the engine exhaust to the outside.

Note: The engine may be equipped with a device for cold starting. If the engine will be operated in cold conditions, then an extra cold starting aid may be required. Normally, the engine will be equipped with the correct type of starting aid for your region of operation.

i07668288

Engine Stopping

- Remove the load in increments.
- Open the circuit breaker.
- Allow the engine to run for five minutes to cool.
- Stop the engine.

Use the Emergency Stop Button (if equipped) ONLY in an emergency situation. Do not use the Emergency Stop Button for normal engine stopping. After an emergency stop, DO NOT start the engine until the problem that caused the emergency stop has been corrected.

Stop the engine if an overspeed condition occurs during the initial start-up of a new engine or an engine that has been overhauled. This may be accomplished by shutting off the fuel supply to the engine and/or shutting off the air supply to the engine.

To stop an electronically controlled engine, cut the power to the engine.

i06214263

Electrical System

Never disconnect any charging unit circuit or battery circuit cable from the battery when the charging unit is operating. A spark can cause the combustible gases that are produced by some batteries to ignite.

To help prevent sparks from igniting combustible gases that are produced by some batteries, the negative “-” jump-start cable should be connected last from the external power source to the negative “-” terminal of the starting motor. If the starting motor is not equipped with a negative “-” terminal, connect the jump-start cable to the engine block.

Check the electrical wires daily for wires that are loose or frayed. Tighten all loose electrical wires before the engine is started. Repair all frayed electrical wires before the engine is started. Refer to the Operation and Maintenance Manual, “Engine Starting” for specific starting instructions.

Grounding Practices

Proper grounding for the engine electrical system is necessary for optimum engine performance and reliability. Improper grounding will result in uncontrolled electrical circuit paths and in unreliable electrical circuit paths.

Uncontrolled electrical circuit paths can result in damage to main bearings, to crankshaft bearing journal surfaces, and to aluminum components.

Engines that are installed without engine-to-frame ground straps can be damaged by electrical discharge.

To ensure that the engine and the engine electrical systems function properly, an engine-to-frame ground strap with a direct path to the battery must be used. This path may be provided by way of a starting motor ground, a starting motor ground to the frame, or a direct engine ground to the frame.

All grounds should be tight and free of corrosion. The engine alternator must be grounded to the negative “-” battery terminal with a wire that is adequate to handle the full charging current of the alternator.

i06214264

Engine Electronics

WARNING

Tampering with the electronic system installation or the OEM wiring installation can be dangerous and could result in personal injury or death and/or engine damage.

This engine has a comprehensive, programmable Engine Monitoring System. The Electronic Control Module (ECM) will monitor the engine operating conditions. If any of the engine parameters extend outside an allowable range, the ECM will initiate an immediate action.

The following actions are available for engine monitoring control: WARNING, DERATE and SHUTDOWN. These engine monitoring modes can limit engine speed and/or the engine power.

Many of the parameters that are monitored by the ECM can be programmed for the engine monitoring functions. The following parameters can be monitored as a part of the Engine Monitoring System:

- Operating Altitude
- Engine Coolant Level
- Engine Coolant Temperature
- Engine Oil Pressure

- Engine Speed
- Fuel Temperature
- Intake Manifold Air Temperature
- System Voltage

The Engine Monitoring package can vary for different engine models and different engine applications. However, the monitoring system and the engine monitoring control will be similar for all engines.

Note: Many of the engine control systems and display modules that are available for Perkins Engines will work in unison with the Engine Monitoring System. Together, the two controls will provide the engine monitoring function for the specific engine application. Refer to the Troubleshooting manual for more information.

Product Information Section

General Information

i06919047

Model View Illustrations

The following model views show typical features of the engine. Due to individual applications, your engine may appear different from the illustrations.

Engine Views

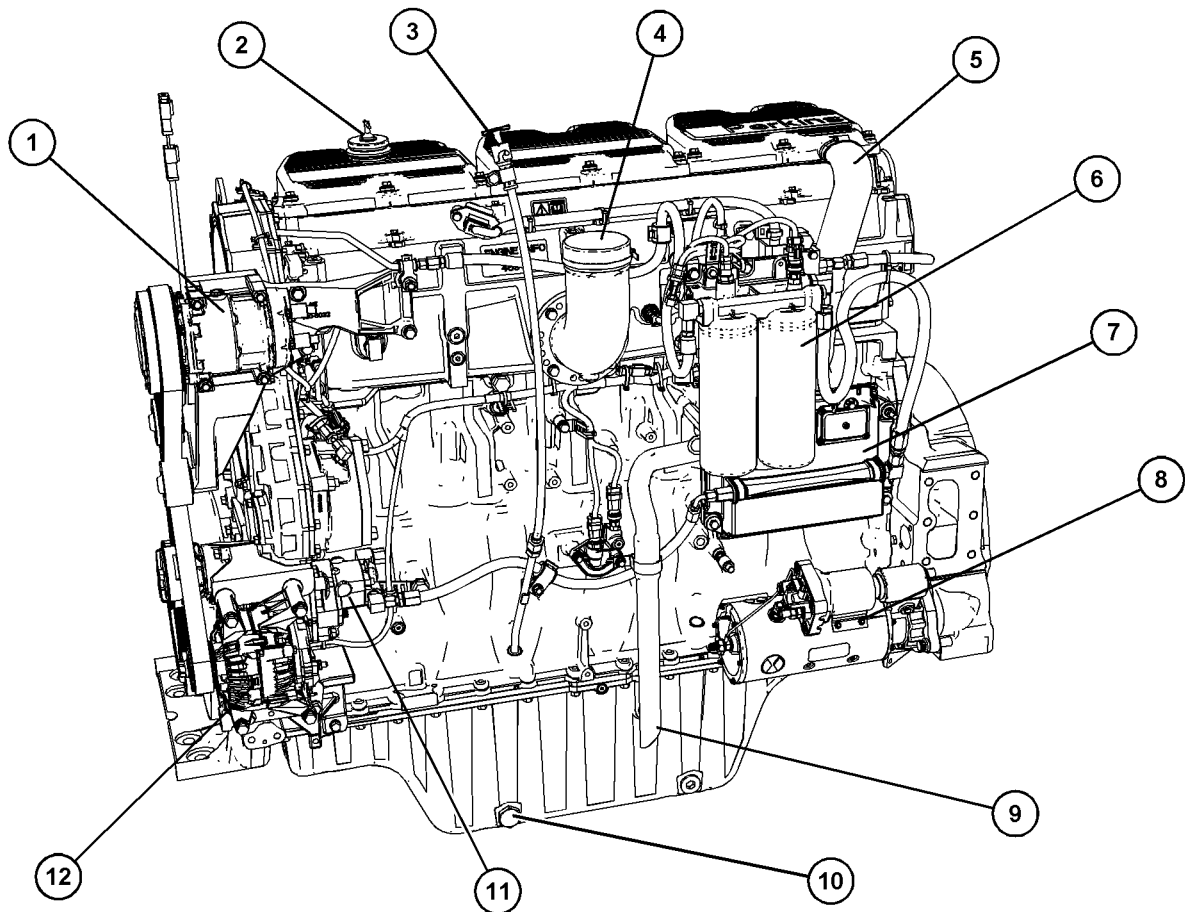

Illustration 12

g06167718

Typical example

- (1) Refrigerant compressor
- (2) Oil filler cap
- (3) Oil gauge (Dipstick)
- (4) Air intake

- (5) Breather hose
- (6) Secondary fuel filters
- (7) Electronic control module
- (8) Starting motor

- (9) Breather outlet
- (10) Oil drain plug
- (11) Fuel transfer pump
- (12) Alternator

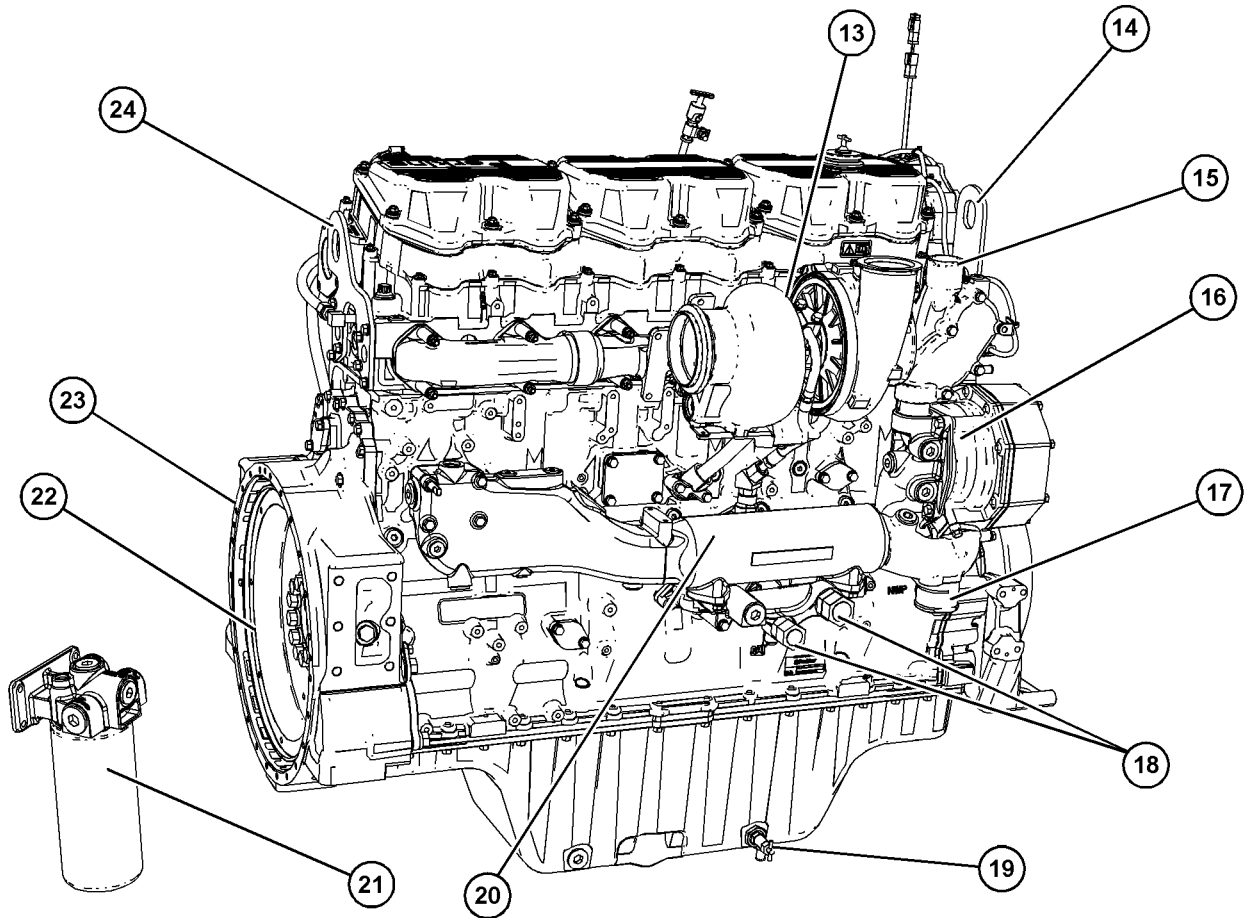

Illustration 13

g06167725

Typical example

(13) Turbocharger
(14) Front lifting eye
(15) Coolant outlet
(16) Coolant pump

(17) Coolant intake
(18) Connections to remote oil filter
(19) Oil drain valve
(20) Oil cooler

(21) Remote oil filter
(22) Flywheel
(23) Flywheel housing
(24) Rear lifting eye

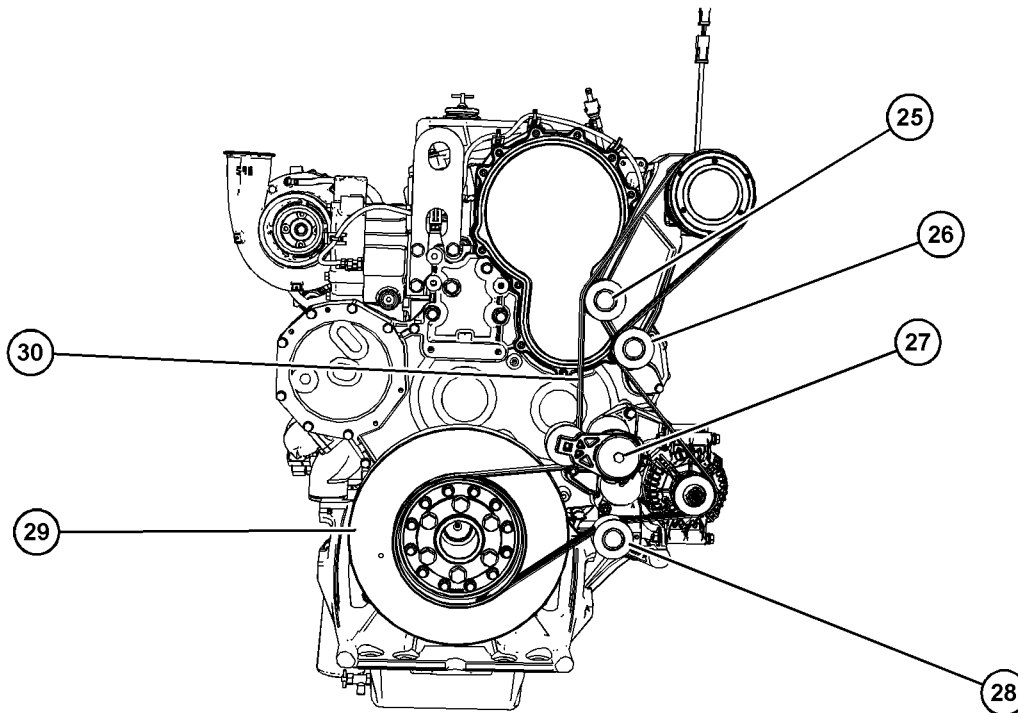

Illustration 14

g06167762

Typical example

(25) Drive belt idler
(26) Drive belt idler

(27) Auto Tensioner for drive belt
(28) Drive belt idler

(29) Damper
(30) Drive belt

i06925231

Product Description

The Perkins 2506D-E15TA Industrial Engine has the following characteristics:

- Four-stroke cycle
- Mechanically actuated, electronically controlled fuel injection system
- Turbocharged
- Air to air charged cooled

Engine Specifications

Note: The front end of the engine is opposite the flywheel end of the engine. The left and the right sides of the engine are determined from the flywheel end. The number 1 cylinder is the front cylinder.

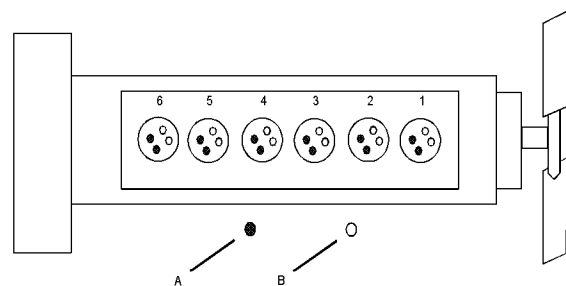

Illustration 15

g01387009

Cylinder and valve location

(A) Exhaust valve
(B) Inlet valve

Table 1

Engine Specifications	
Engine	2506D

(continued)

(Table 1, contd)

Arrangement and Cylinders	In-Line 6 cylinder
Bore	137.2 mm (5.4 inch)
Stroke	171.5 mm (6.8 inch)
Aspiration	ATAAC ⁽¹⁾
Displacement	15.2 L (928 cubic inch)
Firing Order	1-5-3-6-2-4
Rotation (flywheel end)	Counterclockwise

⁽¹⁾ Air-to-air aftercooled

Electronic Engine Features

The engine is designed for electronic controls. The integral on board computer controls the operation of the engine. Current operating conditions are monitored. The Electronic Control Module (ECM) controls the response of the engine to these conditions and to the demands of the operator. These conditions and operator demands determine the precise control of fuel injection by the ECM. The electronic engine control system provides the following features:

- Engine speed governor
- Automatic air/fuel ratio control
- Torque rise shaping
- Injection timing control
- System diagnostics

Extra Features

The following extra features provide increased engine fuel economy and serviceability:

- Cold starting capability
- Tampering detection
- Diagnostics

Engine Diagnostics

The engine has built-in diagnostics to ensure that all the components are functioning properly. Under certain conditions, the engine horsepower and the vehicle speed may be limited. An electronic service tool may be used to display the diagnostic code.

There are two categories of codes: diagnostic code and event code. These two categories of codes may be in two different states: active and logged.

Most of the diagnostic codes are logged and stored in the ECM. For additional information, refer to the Operation and Maintenance Manual, Engine Diagnostic topic (Operation Section).

Engine Service Life

Engine efficiency and maximum utilization of engine performance depend on the adherence to proper operation and maintenance recommendations. In addition, use recommended fuels, coolants, and lubricants. Use the Operation and Maintenance Manual as a guide for required engine maintenance.

Expected engine life is predicted by the average power that is demanded. The average power that is demanded is based on fuel consumption of the engine over a time. Reduced hours of operation at full throttle and/or operating at reduced throttle settings result in a lower average power demand. Reduced hours of operation will increase the length of operating time before an engine overhaul is required. For more information, refer to the Operation and Maintenance Manual, "Overhaul Considerations" topic.

Aftermarket Products and Perkins Engines

Perkins does not warrant the quality or performance of non-Perkins fluids and filters.

When auxiliary devices, accessories, or consumables (filters, additives, catalysts) which are made by other manufacturers are used on Perkins products, the Perkins warranty is not affected simply because of such use.

However, failures that result from the installation or use of other manufacturers devices, accessories, or consumables are NOT Perkins defects. Therefore, the defects are NOT covered under the Perkins warranty.

Product Identification Information

i06925245

Plate Locations and Film Locations

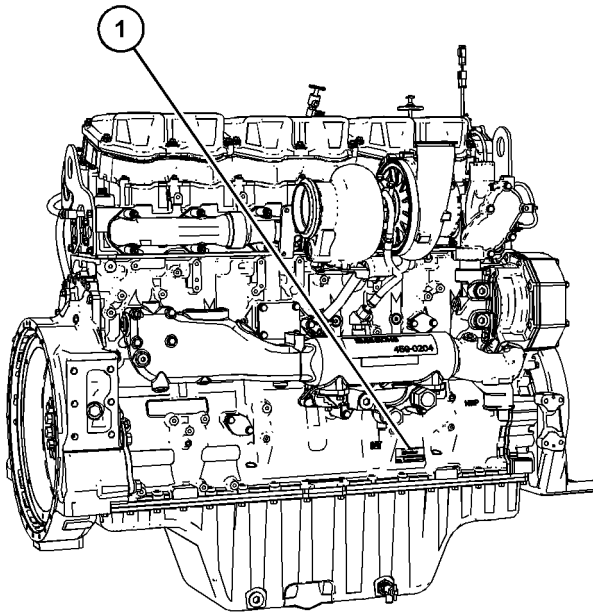

Illustration 16

g06169809

Typical example

The engine serial number plate is on the right side of the engine block.

Perkins Engine Company Ltd England	
 PERKINS	
Engine No.	<input type="text"/>
Designation.	<input type="text"/>
Engine Rating.	<input type="text"/>
<small>For spares quote Engine No.</small>	

Illustration 17

g01403841

Serial number plate

The following information is stamped on the serial number plate: engine serial number, engine model, and arrangement number.

i06925248

Emissions Certification Film

The emissions label is on the oil cooler.

Operation Section

Lifting and Storage

i07444655

Lifting eyes are designed and installed for the specific engine arrangement. Alterations to the lifting eyes and/or the engine make the lifting eyes and the lifting fixtures obsolete. If alterations are made, ensure that proper lifting devices are provided. Consult your Perkins distributor for information regarding fixtures for proper engine lifting.

Product Lifting

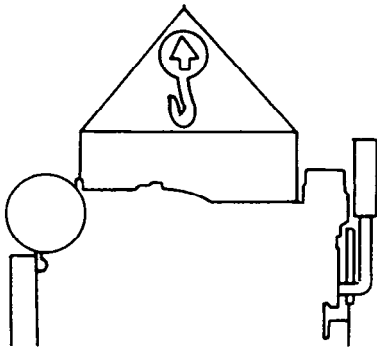

Illustration 18

g00103219

NOTICE

Always inspect lifting eyebolts and all other lifting equipment for damage before performing any lifting. Never bend the eyebolts and the brackets. Never perform product lifting if components are damaged.

NOTICE

Never bend the eyebolts and the brackets. Only load the eyebolts and the brackets under tension. Remember that the capacity of an eyebolt is less as the angle between the supporting members and the object becomes less than 90 degrees.

When it is necessary to remove a component at an angle, only use a link bracket that is properly rated for the weight.

Use a hoist to remove heavy components. Use an adjustable lifting beam to lift the engine. All supporting members (chains and cables) should be parallel to each other. The chains and cables should be perpendicular to the top of the object that is being lifted.

Some removals require lifting the fixtures to obtain proper balance and safety.

To remove the engine **ONLY**, use the lifting eyes that are on the engine.

Engine Lifting

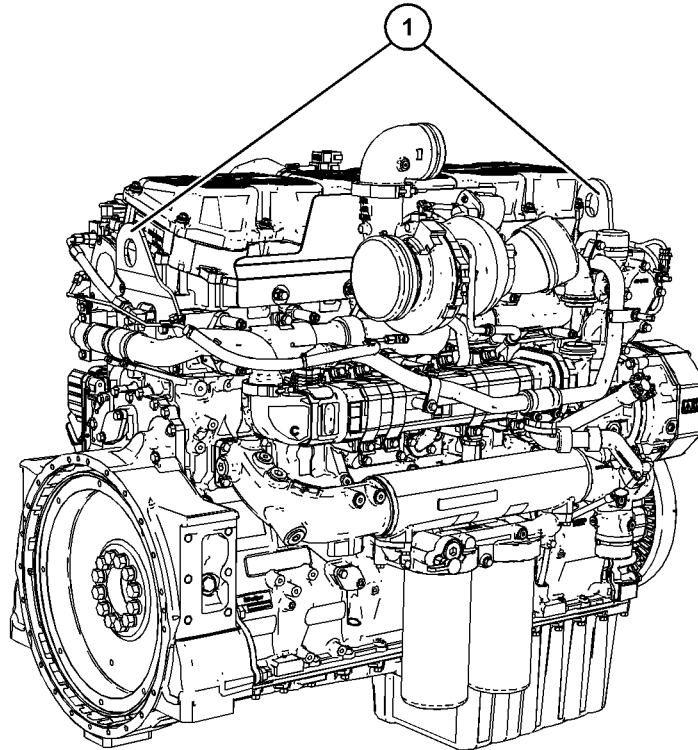

Illustration 19

g06044076

Typical example

(1) Engine lifting eyes

Use an appropriate spreader set so that lifting chains are perpendicular to the engine.

i06216666

Product Storage

Your Perkins distributor can assist in preparing the engine for extended storage periods.

An engine can be stored for up to 6 months provided all the recommendation are adhered to.

Engine

1. Clean the engine of any dirt, rust, grease, and oil. Inspect the exterior. Paint areas that contain paint damage with a good quality paint.
2. Remove dirt from the air cleaners. Check all seals, gaskets, and the filter element for damage.

3. Apply lubricant to all points in this Operation and Maintenance Manual, "Maintenance Interval Schedule".
 4. Drain the crankcase oil. Replace the crankcase oil and change the oil filters. For the proper procedure, refer to this Operation and Maintenance Manual.
 5. Add VCI oil to the crankcase oil. The volume of VCI oil in the crankcase oil should be 3 to 4 percent.
- Note:** If the engine crankcase is full, drain enough engine oil so the mixture can be added.
6. Remove the air filter elements. Turn the engine at cranking speed with the throttle control in FUEL OFF position. Use a sprayer to add a mixture of 50 percent VCI oil and 50 percent engine oil into the air inlet or turbocharger inlet.

Note: The mixture can be added to the inlet by removing the plug on the air inlet elbow on the left side of the engine. The minimum application rate for the VCI oil mixture is 5.5 mL per L (3 oz per 1000 cu in) of engine displacement.

7. Use a sprayer to apply a mixture of 50 percent VCI oil and 50 percent crankcase oil into the exhaust openings. The minimum application rate for the oil mixture is 5.5 mL per L (3 oz per 1000 cu in) of engine displacement. Seal the exhaust pipe and seal any drain holes in the muffler.

8. Empty and reinstall the spin-on fuel filter element in order to remove any dirt and water. Drain any sleeve metering fuel pump.

Clean the primary fuel filter. Fill with calibration fluid or kerosene. Install the primary fuel filter and operate the priming pump. This procedure will send clean oil to the secondary filter and the engine.

Open the fuel tank drain valve in order to drain any water and dirt from the fuel tank. Apply a spray of calibration fluid or kerosene at the rate of 30 mL per 30 L (1 oz per 7.50 gal US) of fuel tank capacity in order to prevent rust in the fuel tank. Add 0.15 mL per L (.02 oz per 1 gal US) of commercial biocide such as Biobor JF to the fuel.

Apply a small amount of oil to the threads on the fuel tank filler neck and install the cap. Seal all openings to the tank in order to prevent evaporation of the fuel and as a preservative.

9. Remove the fuel injectors. Apply 30 mL (1 oz) of the mixture of oils (50 percent VCI oil and 50 percent engine oil) into each cylinder.

Use a bar or a turning tool in order to turn over the engine slowly. This procedure puts the oil on the cylinder walls. Install all fuel injectors and tighten to the correct torque. Refer to Disassembly and Assembly Manual for more information.

10. Spray a thin amount of a mixture of 50 percent VCI oil and 50 percent engine oil onto the following components: flywheel, ring gear teeth and starter pinion. Install the covers in order to prevent evaporation of the vapors from the VCI oil.

11. Apply a heavy amount of Multipurpose Grease to all outside parts that move, such as rod threads, ball joints, linkage.

Note: Install all covers. Ensure that tape has been installed over all openings, air inlets, exhaust openings, the flywheel housing, the crankcase breathers, the dipstick tubes.

Ensure that all covers are airtight and weatherproof. Use a waterproof weather resistant tape such as Kendall No. 231 or an equivalent. Do not use duct tape. Duct tape will only seal for a short time.

12. Under most conditions, removing the batteries is the best procedure. As an alternative, place the batteries in storage. As needed, periodically charge the batteries while the batteries are in storage.

If the batteries are not removed, wash the tops of the batteries until the tops are clean. Apply an electrical charge to the batteries in order to obtain a specific gravity of 1.225.

Disconnect the battery terminals. Place a plastic cover over the batteries.

13. Remove the drive belts from the engine

14. Place a waterproof cover over the engine. Ensure that the engine cover is secure. The cover should be loose enough to allow air to circulate around the engine in order to prevent damage from condensation.

15. Attach a tag with the storage date to the engine.

16. Remove the waterproof cover at 2 month or 3 month intervals in order to check the engine for corrosion. If the engine has signs of corrosion, repeat the protection procedure.

Coolant System

Completely fill the cooling system before storage.

Refer to this Operation and Maintenance Manual, "Fluid Recommendations" for more information about coolants.

Remove Engine from Storage

1. Remove all outside protective covers.

2. Change the oil and filters.

3. Check the condition of the fan and alternator belts. Replace the belts, if necessary. Refer to this Operation and Maintenance Manual, "Belts - Inspect/Adjust/Replace" for the correct procedure.

4. Replace the fuel filter elements.

5. Remove the plastic covers from the air cleaner elements.

6. Use a bar or a turning tool in order to turn the engine in the normal direction of rotation. The procedure ensures that no hydraulic locks or resistance exist.

7. Before starting the engine, remove the valve cover or covers. Put a large amount of engine oil on the camshaft, cam followers, and valve mechanism in order to prevent damage to the mechanism.

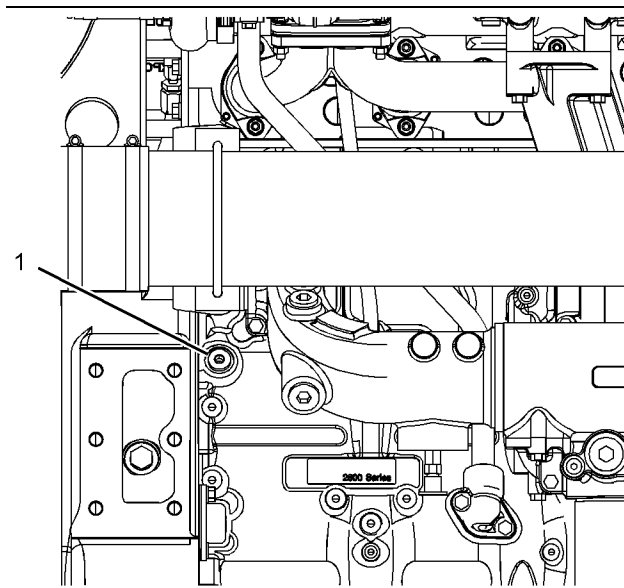

Illustration 20

g03862009

Oil priming point

(1) Plug

8. If an engine is stored for more than 1 year, Perkins recommends prelubrication of the engine in order to avoid dry starting. Use a suitable pump in order to put engine oil into the engine oil system.

The pump will need to create a minimum pressure within the engine of 0.25 bar (3.6 psi). This pressure is needed for 15 seconds in order to lubricate the internal surfaces.

Remove the plug shown in illustration 20 in order to connect to the engine oil system. The connection required is 9/16" x 18 tpi. Ensure that the correct oil specification is used, refer to this Operation and Maintenance Manual, "Fluid Recommendations" for more information. After the engine internal surfaces have been lubricated, remove connector and install plug (1). Tighten plug to a torque of 30 N·m (265 lb in). Perkins recommends that the procedure must be performed in a minimum ambient temperature of 10° C (50° F).

9. Check the condition of all rubber hoses. Replace any worn hoses. Replace any damaged hoses.

10. Before start-up, test the cooling system for a 3 percent to a 6 percent concentration of coolant conditioner. Add liquid coolant conditioner or a coolant conditioner element, if equipped.

Test the coolant mixture for proper nitrite level. If necessary, adjust the coolant mixture.

Prime the engine with clean diesel fuel before starting.

11. Ensure that the cooling system is clean. Ensure that the system is full. Ensure that the system has the correct amount of supplemental cooling system conditioner.
12. On the first day of operation, check the entire engine several times for leaks and correct operation.

Features and Controls

i06216788

Monitoring System

The monitoring system is designed to alert the operator to an immediate problem.

The engine has protection in three stages:

- Warning
- Action Alert
- Shutdown

The engine protection may be overridden by the critical condition mode.

The Electronic Control Module (ECM) monitors the following parameters:

- Engine Temperatures
- Engine Pressures
- Engine Speed

If the parameters exceed a trip point for a period that is longer than the delay period, the ECM logs an event code. The indicator switches to the ON position.

The following parameters are monitored for event codes:

- Lubricating Oil Pressure
- Coolant Temperature
- Overspeed
- Intake Manifold Temperature
- Intake Manifold Pressure
- Fuel Temperature

The temperature protection is disabled for a period when the engine is cranking in order to compensate for heat soak solutions.

The ECM has dedicated alarm outputs for each of the three stages of protection. There are also dedicated alarm outputs for oil pressure, coolant temperature, and overspeed events which are energized at any stage of protection.

Warning Alarm

The Warning alarm informs the user that the engine is approaching a critical condition.

If the engine is in the Warning condition, then the event will be logged in the memory of the ECM. An event code will be transmitted over the Perkins Data link and the hard wired Warning output will be energized. If the engine is in the Warning condition, the event code and output will remain while the condition exists. The electronic service tool is used to remove the event code from the memory of the ECM. The trip point for the Warning alarm will be set to a factory default in production. The electronic service tool may be used to alter the trip point for a Warning within predefined limits.

Action Alert

The Action Alert informs the OEM that the engine is approaching a critical condition. The engine should be stopped in a controlled manner. Further running of the engine may result in an immediate shutdown.

If the engine is in the Action Alert condition, the event will be logged in the memory of the ECM. An event code will be transmitted over the Perkins Data link and the hard wired Action Alert will be energized. If the engine is in the Action Alert condition, the event code and output will remain while the condition exists. The event code cannot be cleared from the memory of the ECM without using a factory password.

Shutdown

If the engine reaches the Shutdown condition, one of the following events has occurred: low lubricating oil pressure, high coolant temperature, or overspeed. The event will be logged in the memory of the ECM. The engine will be shut down. An event code will be transmitted over the Perkins Data link and the hard wired Shutdown output will be energized. The Shutdown condition will latch until the ECM is reset. The event code for the shutdown cannot be cleared from the memory of the ECM without using a factory password.

Critical Protection Override

In an application that is critical for safety, the protection system can be overridden in order to ensure continued engine operation during fault conditions.

Critical Protection Override will be set by a switch input from the OEM. For example, switch to battery + in order to disable a critical override. Critical Protection Override input can be enabled in the electronic service tool by use of a factory password.

When the Critical Protection Override feature is active, the ECM will continue to run the engine in all shutdown conditions except for Overspeed shutdown. If the shutdown is overridden, an event code is generated. The ECM will log the event code. The ECM will energize the following: Warning, Action Alert, Shutdown, oil pressure, coolant temperature and overspeed outputs as normal. The warranty of the engine will be invalidated if the engine is operated in the following conditions: active event code and Critical Protection Override mode.

Standard Warning Outputs

The ECM provides individual outputs in order to drive warning lamps or relays to indicate each of the following fault conditions:

- Diagnostic Fault
- Oil Pressure
- Coolant Temperature
- Overspeed
- Action Alert
- Warning
- Shutdown

If the ECM detects a coolant temperature warning, the warning output will be energized. If the ECM detects a warning for low oil pressure, the warning output will be energized.

If the Action Alert alarms are enabled and the ECM detects a coolant temperature condition, the output on the Action Alert will be energized.

If the engine shuts down on low oil pressure, the output on the shutdown will be energized. If the engine shuts down on coolant temperature, or the engine shuts down on overspeed, the shutdown output will be energized.

Shutdown Reset

The cause of an engine shutdown must be investigated. Corrective action must be taken before the system is reset in order to operate the engine.

After an engine shutdown, operate the reset input of the ECM or power down the controller.

Powering down the electronic control module can be achieved by the operation of the keyswitch into sleep mode. The electronic control module can be powered down by isolating the power supply to the electronic control module.

Note: The ECM cannot be reset by using the Reset input until the engine has stopped.

Diagnostic

If there is a fault with an engine protection sensor on the engine, the engine activates a diagnostic code. The engine communicates the diagnostic code to the operator via the Diagnostic output. The diagnostic code provides an indication to the operator of a fault with the engine protection system. Running of the engine for a prolonged period in this condition may result in engine failure. The output is normally used to drive lamps or relays.

The following sensors are monitored in order to determine if the sensors are out of the normal range, an open circuit, or a short circuit:

- Atmosphere Pressure
- Lubricating Oil Pressure
- Inlet Manifold Pressure
- Inlet Manifold Temperature
- Fuel Temperature
- Coolant Temperature
- Engine Speed
- Desired Speed Input

The Diagnostic output differs from the Warning and Shutdown outputs. The Warning and Shutdown outputs refer to the operation of the engine. The Diagnostic output refers to the condition of the electronic system and software system.

A diagnostic fault may develop on the lubricating oil pressure or coolant temperature sensors. For example, if a Shutdown protection sensor has a fault, the result will be an engine shutdown, unless the system is in critical protection override. If a diagnostic fault occurs, with one of the engine speed sensors while the engine is running. The engine continues to run by using the other timing sensor for reference.

i06925252

Sensors and Electrical Components

The illustrations within the following sections are typical location of the sensors or electrical components for an industrial engine. Specific engines may appear different due to differences in applications.

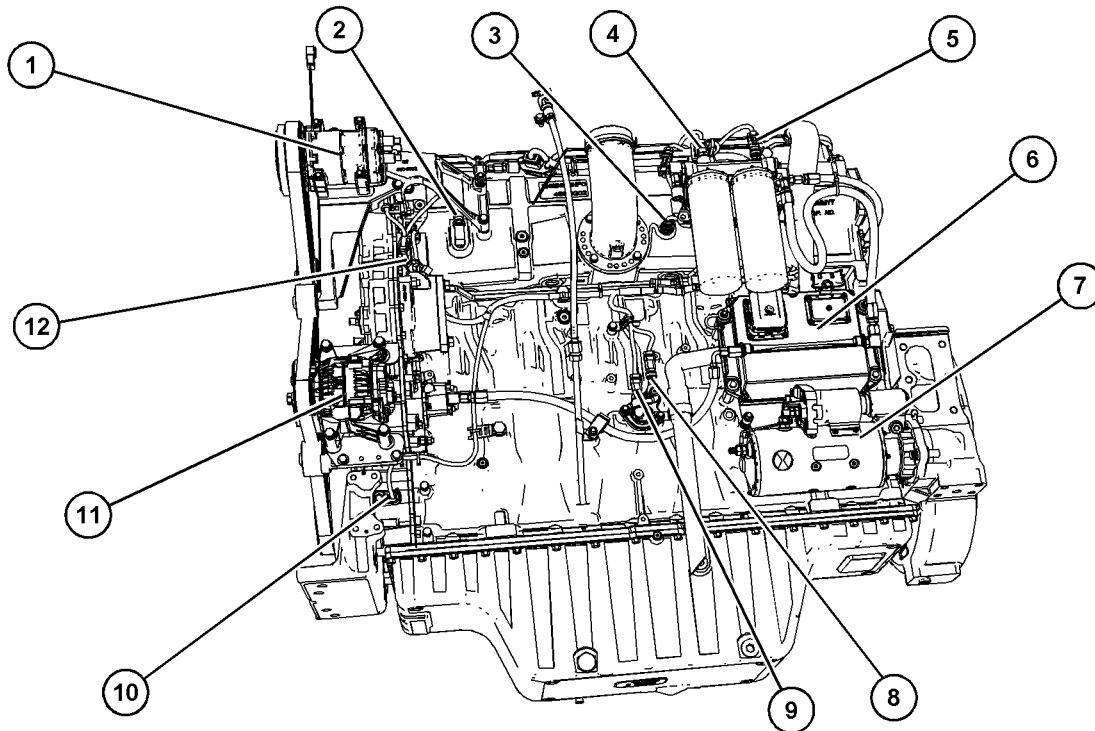

Illustration 21

g06169874

Typical example

- | | | |
|---------------------------------|-------------------------------|------------------------------------|
| (1) Refrigerant compressor | (5) Fuel pressure sensor | (9) Atmospheric pressure sensor |
| (2) Boost pressure sensor | (6) Electronic control module | (10) Primary speed/timing sensor |
| (3) Manifold temperature sensor | (7) Starting motor | (11) Alternator |
| (4) Fuel temperature sensor | (8) Oil pressure sensor | (12) Secondary Speed/timing sensor |

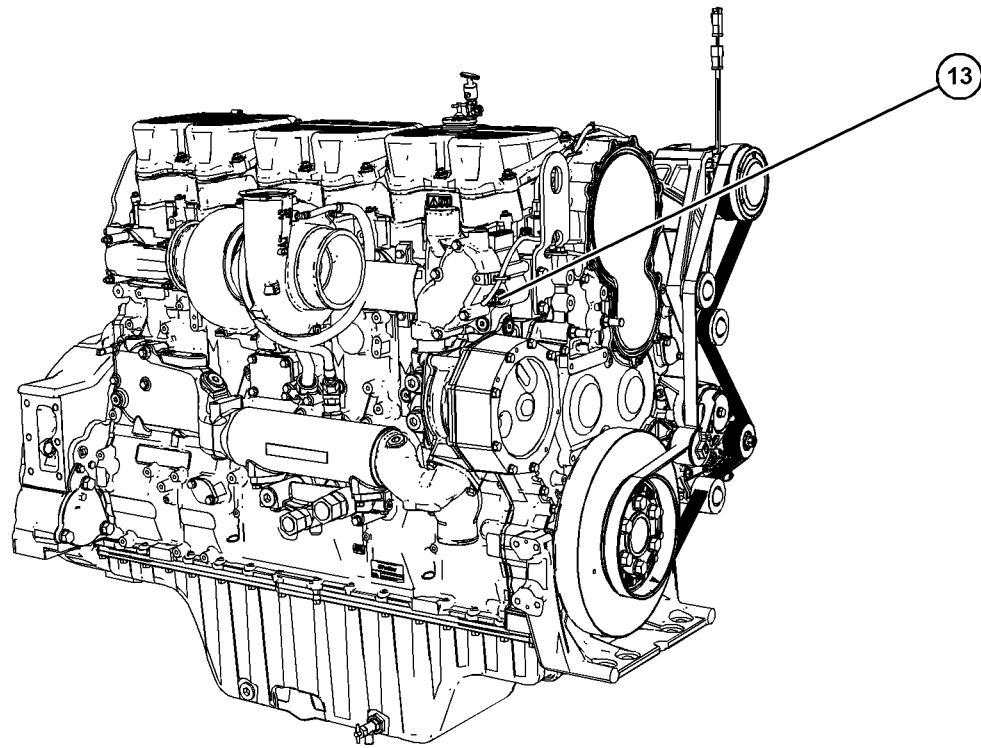

Illustration 22

g06169876

Typical example

(13) Coolant temperature sensor

Engine Diagnostics

i06217560

Self-Diagnostics

i06217555

Perkins Electronic Engines can perform a self-diagnostics test. When the system detects an active problem, a diagnostic lamp is activated. Diagnostic codes will be stored in permanent memory in the Electronic Control Module (ECM). The diagnostic codes can be retrieved by using the Perkins Electronic Service Tool (EST).

Some installations have electronic displays that provide direct readouts of the engine diagnostic codes. Refer to the manual that is provided by the OEM for more information on retrieving engine diagnostic codes.

Active codes represent problems that currently exist. These problems should be investigated first.

Logged codes represent the following items:

- Intermittent problems
- Recorded events
- Performance history

The problems may have been repaired since the logging of the code. These codes do not indicate that a repair is needed. The codes are guides or signals when a situation exists. Codes may be helpful to troubleshoot problems.

When the problems have been corrected, the corresponding logged fault codes should be cleared.

i06217559

Diagnostic Lamp

A diagnostic lamp is used to indicate the existence of an active fault. A fault diagnostic code will remain active until the problem is repaired. The diagnostic code may be retrieved by using the electronic service tool.

Fault Logging

The system provides the capability of Fault Logging. When the Electronic Control Module (ECM) generates an active diagnostic code, the code will be logged in the memory of the ECM. The codes that have been logged by the ECM can be identified by the electronic service tool. The active codes that have been logged will be cleared when the fault has been rectified or the fault is no longer active. The following logged faults cannot be cleared from the memory of the ECM without using a factory password: Overspeed, low engine oil pressure, high engine coolant temperature, and aftertreatment codes.

i06217575

Engine Operation with Active Diagnostic Codes

If a diagnostic lamp illuminates during normal engine operation, the system has identified a situation that is not within the specification. Use electronic service tools to check the active diagnostic codes.

Note: If the customer has selected “DERATE” and there is a low oil pressure condition, engine power will be limited until the problem is corrected. If the oil pressure is within the normal range, the engine may be operated at the rated speed and load. However, maintenance should be performed as soon as possible.

The active diagnostic code should be investigated. The cause of the problem should be corrected as soon as possible. If the cause of the active diagnostic code is repaired and there is only one active diagnostic code, the diagnostic lamp will turn off.

Operation of the engine and performance of the engine can be limited as a result of the active diagnostic code that is generated. Acceleration rates may be lower. Refer to the Troubleshooting Guide for more information on the relationship between these active diagnostic codes and engine performance.

i06217564

Engine Operation with Intermittent Diagnostic Codes

If a diagnostic lamp illuminates during normal engine operation and the diagnostic lamp shuts off, an intermittent fault may have occurred. If a fault has occurred, the fault will be logged into the memory of the Electronic Control Module (ECM).

In most cases, an intermittent code will not require the engine to be stopped. The operator should retrieve the logged fault codes and reference the appropriate information in order to identify the nature of the event. The operator should log any observation that could have caused the lamp to light.

- Low power
- Limits of the engine speed
- Excessive smoke

This information can be useful to help troubleshoot the situation. The information can also be used for future reference. For more information on diagnostic codes, refer to the Troubleshooting Guide for this engine.

Engine Starting

i06217584

Before Starting Engine

Perform the required daily maintenance and other periodic maintenance before the engine is started. Inspect the engine compartment. This inspection can help prevent major repairs at a later date. Refer to the Operation and Maintenance Manual, "Maintenance Interval Schedule" for more information.

- For the maximum service life of the engine, make a thorough inspection before the engine is started. Look for the following items: oil leaks, coolant leaks, loose bolts and trash buildup. Remove trash buildup and arrange for repairs, as needed.
- Inspect the aftercooler for loose connections and for debris buildup.
- Inspect the cooling system hoses for cracks and for loose clamps.
- Inspect the alternator and accessory drive belts for cracks, breaks, and other damage.
- Inspect the wiring for loose connections and for worn wires or frayed wires.
- Check the fuel supply. Drain water from the water separator (if equipped). Open the fuel supply valve.

NOTICE

All valves in the fuel return line must be open before and during engine operation to help prevent high fuel pressure. High fuel pressure may cause filter housing failure or other damage.

If the engine has not been started for several weeks, fuel may have drained from the fuel system. Air may have entered the filter housing. Also, when fuel filters have been changed, some air pockets will be trapped in the engine. In these instances, prime the fuel system. Refer to the Operation and Maintenance Manual, "Fuel System - Prime" for more information on priming the fuel system.

WARNING

Engine exhaust contains products of combustion which may be harmful to your health. Always start and operate the engine in a well ventilated area and, if in an enclosed area, vent the exhaust to the outside.

- If there is a "DO NOT OPERATE" warning tag or similar attached to the start switch or the controls, do not start the engine or move any controls.
- Ensure that the areas around the rotating parts are clear.
- All of the guards must be put in place. Check for damaged guards or for missing guards. Repair any damaged guards. Replace damaged guards and/or missing guards.
- Disconnect any battery chargers that are not protected against the high current drain that is created when the electric starting motor (if equipped) is engaged. Check electrical cables and check the battery for poor connections and for corrosion.
- Reset all of the shutoffs or alarm components.
- Check the engine lubrication oil level. Maintain the oil level between the "ADD" mark and the "FULL" mark on the oil level gauge.
- Check the coolant level. Observe the coolant level in the coolant recovery tank (if equipped). Maintain the coolant level to the "FULL" mark on the coolant recovery tank.
- If the engine is not equipped with a coolant recovery tank, maintain the coolant level within 13 mm (0.5 inch) of the bottom of the filler pipe. If the engine is equipped with a sight glass, maintain the coolant level in the sight glass.
- Observe the air cleaner service indicator (if equipped). Service the air cleaner when the yellow diaphragm enters the red zone, or when the red piston locks in the visible position.
- Ensure that any driven equipment has been disengaged. Minimize electrical loads or remove any electrical loads.

i06217593

Cold Weather Starting

Startability will be improved at temperatures below 10°C (50°F) from the use of a cylinder block coolant heater or from other means that are used to heat the crankcase oil. Some engine applications use a jacket water heater to improve startability. Use of a jacket water heater will help reduce white smoke and misfire during start-up in cold weather.

Note: If the engine has not been run for several weeks, fuel may have drained. Air may have moved into the filter housing. Also, when fuel filters have been changed, some air will be left in the filter housing. Refer to the Operation and Maintenance Manual, “Fuel System - Prime” (Maintenance Section) for more information on priming the fuel system.

Ether Injection System (If Equipped)

The ether injection system is controlled by the ECM. The ECM monitors the coolant temperature, intake air temperature, ambient air temperature, and barometric pressure to determine when ether injection is needed. At sea level, ether will be used if any of the temperatures fails to exceed 0° C (32° F). This temperature is subject to an increase as barometric pressure increases.

WARNING

Personal injury or property damage can result from alcohol or starting fluids.

Alcohol or starting fluids are highly flammable and toxic and if improperly stored could result in injury or property damage.

Follow the procedure in this Operation and Maintenance Manual, “Starting the Engine”.

i06217596

Starting the Engine

WARNING

Engine exhaust contains products of combustion which may be harmful to your health. Always start and operate the engine in a well ventilated area and, if in an enclosed area, vent the exhaust to the outside.

Starting the Engine

Refer to the Owners Manual of the OEM for your type of controls. Use the following procedure to start the engine.

1. Remove all driven equipment loads in order to allow the engine to start faster, and to reduce the draining of the battery.
2. Turn the ignition switch to the ON position.

During the key on, all warning lamps will illuminate for a few seconds, in order to test the circuits. If any lamps do not illuminate, check the bulbs and replace as necessary.

NOTICE

Do not engage the starting motor when flywheel is turning. Do not start the engine under load.

If the engine fails to start within 30 seconds, release the starter switch or button and wait two minutes to allow the starting motor to cool before attempting to start the engine again.

3. Push the start button or turn the ignition switch to the START position in order to crank the engine.

Do not push down or hold the throttle down while the engine is cranked. The system will automatically provide the correct amount of fuel that is needed to start the engine.

4. If the engine fails to start within 30 seconds, release the start button, or the ignition switch. Wait for 2 minutes in order to allow the starting motor to cool before attempting to start the engine again.

NOTICE

Oil pressure should rise within 15 seconds after the engine starts. Do not increase engine rpm until the oil pressure gauge indicates normal. If oil pressure is not indicated on the gauge within 15 seconds, DO NOT operate the engine. STOP the engine, investigate and correct the cause.

5. Do not apply a load to the engine for approximately 3 minutes. Run the engine until the water temperature gauge has begun to rise. Check all gauges during the warm-up period.

Note: Oil pressures and fuel pressures should be in the normal range on the instrument panel. Engines that are equipped with “WARNING” lamps do not have an operating range. The “WARNING and DIAGNOSTIC” lamp (if equipped) will flash while the engine is cranking. The lamp should turn off after sufficient engine oil pressure or fuel pressure is achieved. Do not apply a load to the engine until the oil pressure gauge indicates at least normal pressure. Inspect the engine for leaks and/or unusual noises.

If the engine is operated with a low load, the engine will reach normal operating temperature sooner than idling the engine with no load.

Starting Problems

An occasional starting problem may be caused by one of the following items:

- Low battery charge
- Lack of fuel
- Problem with the wiring harness

If the engine fuel system has been run dry, fill the fuel tank and prime the fuel system. Refer to the Operation and Maintenance Manual, "Fuel System - Prime" topic (Maintenance Section).

Problems with the Wiring Harness

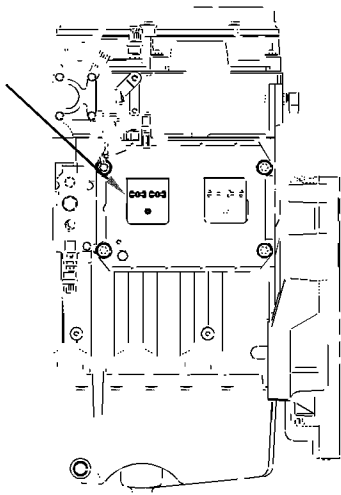

Illustration 23

g01248812

ECM Connector J2/P2

Locate the ECM. Check the connector in order to ensure that the connector is secure. Lightly pull each of the wires in the chassis harness.

1. Pull each wire with approximately 4.5 kg (10 lb) of force. The wire should remain in the connector.
2. If a wire is loose, push the wire back into the connector. Pull the wire again in order to ensure that the wire is secure.

3. Start the engine. If the engine does not start, check for a diagnostic code and consult your Perkins distributor.

i06217616

Starting with Jump Start Cables

(Do Not Use This Procedure in Hazardous Locations that have Explosive Atmospheres)

⚠ WARNING

The connection of battery cables to a battery and the disconnection of battery cables from a battery may cause an explosion which may result in injury or death. The connection and the disconnection of other electrical equipment may also cause an explosion which may result in injury or death. The procedures for the connection and the disconnection of battery cables and other electrical equipment should only be performed in a nonexplosive atmosphere.

⚠ WARNING

Improper jump start cable connections can cause an explosion resulting in personal injury.

Prevent sparks near the batteries. Sparks could cause vapors to explode. Do not allow jump start cable ends to contact each other or the engine.

Note: If possible, first diagnose the reason for the starting failure. Refer to Troubleshooting, "Engine Does Not Crank and Engine Cranks But Does Not Start" for further information. Make any necessary repairs.

If the engine will not start only due to the condition of the battery, perform one of the following procedures:

- Charge the battery
- Start the engine using another battery with jump-start cables

The condition of the battery can be rechecked after the engine has been switched OFF.

NOTICE

Using a battery source with the same voltage as the electric starting motor. Use **ONLY** equal voltage for jump starting. The use of higher voltage will damage the electrical system.

Do not reverse the battery cables. The alternator can be damaged. Attach ground cable last and remove first.

Turn all electrical accessories OFF before attaching the jump start cables.

Ensure that the main power switch is in the OFF position before attaching the jump start cables to the engine being started.

1. Turn the start switch on the stalled engine to the OFF position. Turn off all the engines accessories.
2. Connect one positive end of the jump-start cable to the positive terminal of the discharged battery. Connect the other positive end of the jump-start cable to the positive terminal of the electrical source.
3. Connect one negative end of the jump-start cable to the negative terminal of the electrical source. Connect the other negative end of the jump-start cable to the engine block or to the chassis ground. This procedure helps to prevent potential sparks from igniting the combustible gases that are produced by some batteries.

Note: The engine ECM must be powered before the starting motor is operated or damage can occur.

4. Start the engine in the normal operating procedure. Refer to this Operation and Maintenance Manual, "Starting the Engine".
5. Immediately after the engine is started, disconnect the jump-start cables in reverse order.

After jump starting, the alternator may not be able to recharge batteries to full capacity that are severely discharged. The batteries must be replaced or charged to the correct voltage with a battery charger after the engine is stopped. Many batteries which are considered unusable are still rechargeable. Refer to Operation and Maintenance Manual, "Battery - Replace" and Testing and Adjusting Manual, "Battery - Test".

i06217669

After Starting Engine

Note: In temperatures from 0 to 60°C (32 to 140°F), the warm-up time is approximately 3 minutes. In temperatures below 0°C (32°F), additional warm-up time may be required.

Note: Ensure that the self test for the monitoring system (if equipped) is completed before operating the engine under load.

When the engine idles during warm-up, observe the following conditions:

- Check for any fluid or air leaks (no load on the engine) before operating the engine under load.
- Operate the engine with no load until all systems achieve operating temperatures. Check all gauges during the warm-up period.

Note: Gauge readings should be observed and the data should be recorded frequently while the engine is operating. Comparing the data over time will help to determine normal readings for each gauge. Comparing data over time will also help detect abnormal operating developments. Significant changes in the readings should be investigated.

Engine Operation

i06217673

Engine Operation

Correct operation and maintenance are key factors in obtaining the maximum life and economy of the engine. If the directions in the Operation and Maintenance Manual are followed, costs can be minimized and engine service life can be maximized.

Allow the engine to warm up before applying load.

Gauge readings should be observed and the data should be recorded frequently while the engine is operating. Comparing the data over time will help to determine normal readings for each gauge. Comparing data over time will also help detect abnormal operating developments. Significant changes in the readings should be investigated.

i06217680

Engaging the Driven Equipment

If the load varies, or if the load is cyclic, the governor will adjust the engine rpm, as needed.

Extended operation at a reduced load may cause increased oil consumption and carbon buildup in the cylinders. This carbon buildup results in a loss of power and/or poor performance. When the engine is operated at a reduced load, fully load the engine every 4 hours in order to burn excess carbon from the cylinders.

Industrial Engines

1. When the engine is operating, check the engine gauges. The engine gauges should be in the normal range before you engage the driven equipment.

2. Engage the driven equipment. Begin operating the engine at low load. Check the gauges and check the equipment for proper operation. Check the gauges and check the equipment frequently while the engine is operating under load.

i06217701

Fuel Conservation Practices

The efficiency of the engine can affect the fuel economy. Perkins design and technology in manufacturing provides maximum fuel efficiency in all applications. Follow the recommended procedures in order to attain optimum performance for the life of the engine.

- Avoid spilling fuel.

Fuel expands when the fuel is warmed up. The fuel may overflow from the fuel tank. Inspect fuel lines for leaks. Repair the fuel lines, as needed.

- Be aware of the properties of the different fuels. Use only the recommended fuels. Refer to the Operations and Maintenance Manual, "Fuel Recommendations" for further information.
- Avoid unnecessary idling.

Shut off the engine rather than idle for long periods of time.

- Observe the service indicator frequently. Keep the air cleaner elements clean.
- Ensure that the turbochargers are operating correctly. For more information refer to this Operation and Maintenance Manual, "Turbocharger - Inspect"
- Maintain a good electrical system.

One faulty battery cell will overwork the alternator. This fault will consume excess power and excess fuel.

- The belts must be in good condition. Refer to the Systems Operation, Testing and Adjusting, "Belts - Adjust" for further information.
- Ensure that all of the connections of the hoses are tight. The connections should not leak.
- Ensure that the driven equipment is in good working order.

- Cold engines consume excess fuel. Utilize heat from the jacket water system and the exhaust system, when possible. Keep cooling system components clean and keep cooling system components in good repair. Never operate the engine without a water temperature regulator. All of these items will help maintain operating temperatures.

Cold Weather Operation

i06219089

Radiator Restrictions

Perkins discourages the use of airflow restriction devices that are mounted in front of radiators. Airflow restriction can cause the following conditions:

- High exhaust temperatures
- Power loss
- Excessive fan usage
- Reduction in fuel economy

Reducing air flow over components will also affect under hood temperatures.

If an airflow restriction device must be used, the device should have a permanent opening directly in line with the fan hub. The device must have a minimum opening dimension of at least 770 cm² (120 in²).

A centered opening that is directly in line with the fan hub is specified in order to prevent an interrupted airflow on the fan blades. Interrupted airflow on the fan blades could cause a fan failure.

Perkins recommends a warning device for the inlet manifold temperature and/or the installation of an inlet air temperature gauge. The warning device for the inlet manifold temperature should be set at 75 °C (167 °F). The inlet manifold air temperature should not exceed 75 °C (167 °F). Temperatures that exceed this limit can cause power loss and potential engine damage.

i06219102

Fuel and the Effect from Cold Weather

Note: Only use grades of fuel that are recommended by Perkins. Refer to this Operation and Maintenance Manual, “Fluid Recommendations”.

Properties of the diesel fuel can have a significant effect on the engine cold start capability. It is critical that the low temperature properties of diesel fuel are acceptable for the minimum ambient temperature the engine will see in operation.

The following properties are used to define fuel low temperature capability:

- Cloud point

- Cold Filter Plugging Point (CFPP)
- Pour point

The cloud point of the fuel is the temperature at which waxes naturally found in the diesel fuel begin to form crystals. The cloud point of the fuel must be below lowest ambient temperature to prevent filters from plugging.

Cold Filter Plugging Point is a temperature at which a particular fuel will pass through a standardized filtration device. This CFPP gives an estimate of the lower operability temperature of fuel

Pour point is the last temperature before the fuel flow stops and waxing of the fuel will start.

Be aware of these properties when diesel fuel is purchased. Consider the average ambient air temperature for the engines application. Engines that are fueled in one climate may not operate well if the engines are shipped to colder climate. Problems can result due to changes in temperature.

Before troubleshooting for low power or for poor performance in the winter, check the fuel for waxing.

The following components can provide a means of minimizing fuel waxing problems in cold weather:

- Fuel heaters, which may be an OEM option
- Fuel line insulation, which may be an OEM option

Winter and arctic grades of diesel fuel are available in the countries and territories with severe winters. For more information refer to the Operation and Maintenance Manual, “Fuel For Cold Weather Operation”

Another important fuel property which can affect cold start and operation of diesel engine is the Cetane number. Detail and requirements of this property are given in this Operation and Maintenance Manual, “Fluid Recommendations”.

i06219103

Fuel Related Components in Cold Weather

Fuel Tanks

Condensation can form in partially filled fuel tanks. Top off the fuel tanks after operating the engine.

Fuel tanks should contain a provision for draining water and sediment from the bottom of the tanks. Some fuel tanks use supply pipes that allow water and sediment to settle below the end of the fuel supply pipe.

Some fuel tanks use supply lines that take fuel directly from the bottom of the tank. If the engine is equipped with this system, regular maintenance of the fuel system filter is important.

Drain the water and sediment from any fuel storage tank at the following intervals:

- Weekly
- Oil changes
- Refueling of the fuel tank

This draining will help prevent water and/or sediment from being pumped from the fuel storage tank and into the engine fuel tank.

Fuel Heaters

Fuel heaters help to prevent fuel filters from plugging in cold weather due to waxing. A fuel heater should be installed in order for the fuel to be heated before the fuel enters the primary fuel filter.

Select a fuel heater that is mechanically simple, yet adequate for the application. The fuel heater should also help to prevent overheating of the fuel. High fuel temperatures reduce engine performance and the availability of engine power. Choose a fuel heater with a large heating surface. The fuel heater should be practical in size. Small heaters can be too hot due to the limited surface area.

Disconnect the fuel heater in warm weather.

Note: Fuel heaters that are controlled by the water temperature regulator or self-regulating fuel heaters should be used with this engine. Fuel heaters that are not controlled by the water temperature regulator can heat the fuel in excess of 65° C (149° F). A loss of engine power can occur if the fuel supply temperature exceeds 37° C (100° F).

Note: Heat exchanger type fuel heaters should have a bypass provision in order to prevent overheating of the fuel in warm-weather operation.

For further information on fuel heaters, consult a Perkins distributor.

Engine Stopping

i06219104

Stopping the Engine

i06219131

NOTICE

Stopping the engine immediately after it has been working under load, can result in overheating and accelerated wear of the engine components.

Avoid accelerating the engine prior to shutting it down.

Avoiding hot engine shutdowns will maximize turbo-charger shaft and bearing life.

Note: Individual applications will have different control systems. Ensure that the shutoff procedures are understood. Use the following general guidelines in order to stop the engine.

1. Remove the load from the engine. Allow the engine to cool for 5 minutes.
2. Stop the engine after the cool down period according to the shutoff system on the engine. Turn the ignition key switch to the OFF position. If necessary, refer to the instructions that are provided by the OEM.

i06219122

Manual Stop Procedure

NOTICE

Stopping the engine immediately after it has been working under load can result in overheating and accelerated wear of the engine components.

If the engine has been operating at high rpm and/or high loads, run at low idle for at least three minutes to reduce and stabilize internal engine temperature before stopping the engine.

Avoiding hot engine shutdowns will maximize turbo-charger shaft and bearing life.

Note: Individual applications have different control systems. Ensure that the shutoff procedures are understood. Use the following general guidelines in order to stop the engine.

1. Remove the load from the engine so that the engine has no more than 30% power.

2. Run the engine for at least 3 minutes.
3. After the cool down period, turn the start switch to the OFF position.

After Stopping Engine

Note: Before checking the engine oil, do not operate the engine for at least 10 minutes. The delay is needed in order to allow the engine oil to return to the oil pan.

- Check the crankcase oil level. Maintain the oil level between the “ADD” mark and the “FULL” mark on the oil level gauge.
 - If necessary, perform minor adjustments. Repair any leaks and tighten any loose bolts.
 - Note the service hour meter reading. Perform the maintenance that is in the Operation and Maintenance Manual, “Maintenance Interval Schedule”.
 - Replenish the fuel tank in order to help prevent accumulation of moisture in the fuel. Do not overfill the fuel tank.
-

NOTICE

Only use antifreeze/coolant mixtures recommended in the Coolant Specifications that are in the Operation and Maintenance Manual. Failure to do so can cause engine damage.

- Allow the engine to cool. Check the coolant level.
- If freezing temperatures are expected, check the coolant for proper antifreeze protection. The cooling system must be protected against freezing to the lowest expected outside temperature. Add the proper coolant/water mixture, if necessary.
- Perform all required periodic maintenance on all driven equipment. This maintenance is outlined in the instructions from the OEM.

Maintenance Section

Refill Capacities

i06937316

Refill Capacities and Recommendations

Refill Capacities

Lubricant Refill Capacity

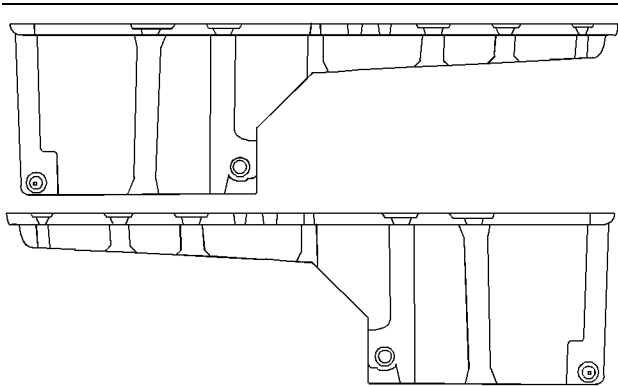

Illustration 24 g02300456
Standard pan

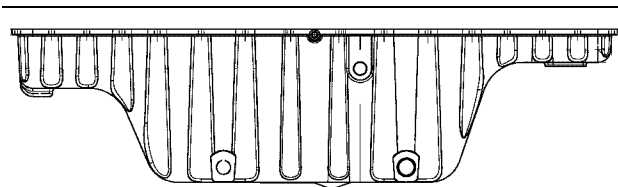

Illustration 25 g02300473
Center pan

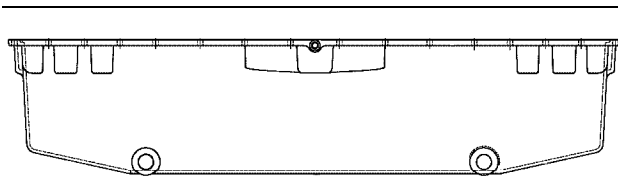

Illustration 26 g02300474
Deep pan

The refill capacities for the engine crankcase reflect the approximate capacity of the crankcase or sump plus standard oil filters. Auxiliary oil filter systems will require extra oil. Refer to the OEM specifications for the capacity of the auxiliary oil filter.

Table 2

2000 Series Industrial Engines Approximate Refill Capacities		
Oil Sump ⁽¹⁾	Engine with 1 Filter	Engine with 2 Filters
Standard pan	34 L (36 qt)	43 L (45 qt)
Center pan	60 L (63 qt)	62 L (66 qt)
Deep pan	68 L (72 qt)	70 L (74 qt)

⁽¹⁾ These values are approximate capacities for the crankcase oil sump which include the standard oil filters that are installed at the factory. Engines with auxiliary oil filters will require extra oil. Refer to the OEM specifications for the capacity of the auxiliary oil filter.

Coolant Refill Capacity

To maintain the cooling system, the total cooling system capacity must be known. The capacity of the total cooling system will vary. The capacity will depend on the size of the radiator (capacity). Table 3 should be completed by the customer for the maintenance of the cooling system.

Table 3

Approximate Capacity of the Cooling System		
Compartment or System	Liters	Quarts
Total Cooling System ⁽¹⁾		

⁽¹⁾ The total cooling system capacity includes the following components: The engine block, the radiator, and all coolant hoses and lines.

Recommendation

Refer to this Operation and Maintenance Manual, "Fluid Recommendations" for information about the fluids which are acceptable for this engine.

i06219169

Fluid Recommendations

General Lubricant Information

Because of government regulations regarding the certification of exhaust emissions from the engine, the lubricant recommendations must be followed.

- API _____ American Petroleum Institute

- SAE _____ Society Of Automotive Engineers Inc.

Licensing

The Engine Oil Licensing and Certification System by the American Petroleum Institute (API). For detailed information about this system, see the latest edition of the “API publication No. 1509”. Engine oils that bear the API symbol are authorized by API.

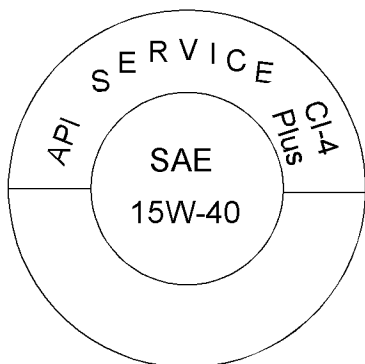

Illustration 27 g03813274
Typical API symbol

Terminology

Certain abbreviations follow the nomenclature of “SAE J754”. Some classifications follow “SAE J183” abbreviations, and some classifications follow the “EMA Recommended Guideline on Diesel Engine Oil”. In addition to Perkins definitions, there are other definitions that will be of assistance in purchasing lubricants. Recommended oil viscosities can be found in this publication, “Fluid Recommendations/ Engine Oil” topic (Maintenance Section).

Engine Oil

Commercial Oils

NOTICE

Perkins require the use of the following specification of engine oil. Failure to use the appropriate specification of engine oil will reduce the life of your engine.

Table 4

Oil Specification	
Preferred Oil Specification	Acceptable
API CI-4 Plus	API CI-4

API CI-4 Plus meets the designed life of the product, the use of the appropriate engine oil is essential.

API CI-4 Plus provide two design improvements over API CI-4 oil specification, soot viscosity control and product shear stability.

Maintenance intervals for engines that use biodiesel – The oil change interval can be adversely affected by the use of biodiesel. Use oil analysis in order to monitor the condition of the engine oil. Use oil analysis also in order to determine the oil change interval that is optimum.

Note: These engine oils are not approved by Perkins and these engine oils must not be used: CC, CD, CD-2, CF-4, CG-4 and CH-4.

Lubricant Viscosity Recommendations for Direct Injection (DI) Diesel Engines

The correct SAE viscosity grade of oil is determined by the minimum ambient temperature during cold engine start-up, and the maximum ambient temperature during engine operation.

Refer to illustration 28 (minimum temperature) in order to determine the required oil viscosity for starting a cold engine.

Refer to illustration 28 (maximum temperature) in order to select the oil viscosity for engine operation at the highest ambient temperature that is anticipated.

Generally, use the highest oil viscosity that is available to meet the requirement for the temperature at start-up.

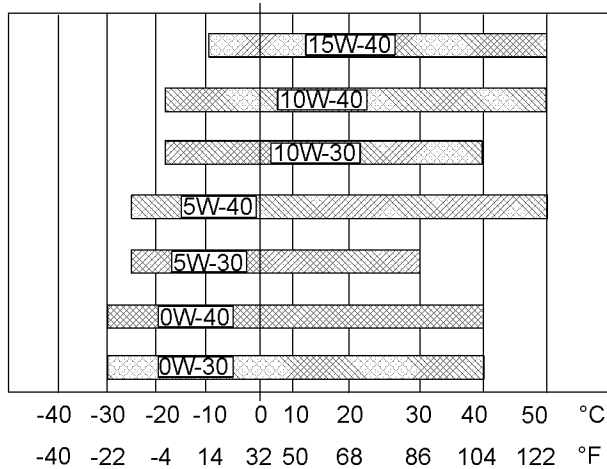

Illustration 28

g03329707

Lubricant Viscosities

Supplemental heat is recommended for cold soaked starts below the minimum ambient temperature. Supplemental heat may be required for cold soaked starts that are above the minimum temperature that is stated. The requirement also depends on the parasitic load and other factors. Cold soaked starts occur when the engine has not been operated for a longtime. This interval will allow the oil to become more viscous due to cooler ambient temperatures.

Aftermarket Oil Additives

Perkins does not recommend the use of aftermarket additives in oil. The use of aftermarket additives in order to achieve the engines maximum service life or rated performance is not necessary. Fully formulated, finished oils consist of base oils and of commercial additive packages. Additive packages are blended into the base oils at precise percentages in order to provide finished oils with performance characteristics that meet industry standards.

There are no industry standard tests that evaluate the performance or the compatibility of aftermarket additives in finished oil. Aftermarket additives may not be compatible with the finished oils additive package, which could lower the performance of the finished oil. The aftermarket additive could fail to mix with the finished oil. This failure could produce sludge in the crankcase. Perkins discourages the use of aftermarket additives in finished oils.

To achieve the best performance from a Perkins engine, conform to the following guidelines:

- See the appropriate "Lubricant Viscosities". Refer to the illustration 28 in order to find the correct oil viscosity grade for your engine.

- At the specified interval, service the engine. Use new oil and install a new oil filter.
- Perform maintenance at the intervals that are specified in the Operation and Maintenance Manual, "Maintenance Interval Schedule".

Oil analysis

Some engines may be equipped with an oil sampling valve. If oil analysis is required, the oil sampling valve is used to obtain samples of the engine oil. The oil analysis will complement the preventive maintenance program.

The oil analysis is a diagnostic tool that is used to determine oil performance and component wear rates. Contamination can be identified and measured by using oil analysis. The oil analysis includes the following tests:

- The Wear Rate Analysis monitors the wear of the engines metals. The amount of wear metal and type of wear metal that is in the oil is analyzed. The increase in the rate of engine wear metal in the oil is as important as the quantity of engine wear metal in the oil.
- Tests are conducted in order to detect contamination of the oil by water, glycol, or fuel.
- The Oil Condition Analysis determines the loss of the oils lubricating properties. An infrared analysis is used to compare the properties of new oil to the properties of the used oil sample. This analysis allows technicians to determine the amount of deterioration of the oil during use. This analysis also allows technicians to verify the performance of the oil according to the specification during the entire oil change interval.

i06795193

Fluid Recommendations (General Fuel Information)

- **Glossary**
- ISO International Standards Organization
- ASTM American Society for Testing and Materials
- HFRR High Frequency Reciprocating Rig for Lubricity testing of diesel fuels
- FAME Fatty Acid Methyl Esters
- CFR Co-ordinating Fuel Research
- LSD Low Sulfur Diesel

- ULSD Ultra Low Sulfur Diesel
- RME Rape Methyl Ester
- SME Soy Methyl Ester
- EPA Environmental Protection Agency of the United States

General Information

NOTICE

Every attempt is made to provide accurate, up-to-date information. By use of this document you agree that Perkins Engines Company Limited is not responsible for errors or omissions.

NOTICE

These recommendations are subject to change without notice. Contact your local Perkins distributor for the most up-to-date recommendations.

Diesel Fuel Requirements

Perkins is not in a position to evaluate continuously and monitor all worldwide distillate diesel fuel specifications that are published by governments and technological societies.

Perkins Specification for Distillate Diesel Fuel in table 5 provides a known reliable baseline to judge the expected performance of distillate diesel fuels that are derived from conventional sources.

Satisfactory engine performance depends on the use of a good quality fuel. The use of a good quality fuel will give the following results: long engine life and acceptable exhaust emissions levels. The fuel must meet the minimum requirements that are stated in table 5 .

NOTICE

The footnotes are a key part of the Perkins Specification for Distillate Diesel Fuel Table. Read ALL of the footnotes.

Table 5

Perkins Specification for Distillate Diesel Fuel				
Property	UNITS	Requirements	"ASTM Test"	"ISO Test"
Aromatics	%Volume	35% maximum	"D1319"	"ISO 3837"
Ash	%Weight	0.01% maximum	"D482"	"ISO 6245"
Carbon Residue on 10% Bottoms	%Weight	0.35% maximum	"D524"	"ISO 4262"
Cetane Number ⁽¹⁾	-	40 minimum	"D613 or D6890"	"ISO 5165"

(continued)

(Table 5, contd)

Cloud Point	°C	The cloud point must not exceed the lowest expected ambient temperature.	"D2500"	"ISO 3015"
Copper Strip Corrosion	-	No. 3 maximum	"D130"	"ISO 2160"
Distillation	°C	10% at 282 °C (539.6 °F) maximum 90% at 360 °C (680 °F) maximum	"D86"	"ISO 3405"
Density at 15 °C (59 °F) ⁽²⁾	Kg / M ³	800 minimum and 860 maximum	No equivalent test	"ISO 3675" or "ISO 12185"
Flash Point	°C	legal limit	"D93"	"ISO 2719"
Thermal Stability	-	Minimum of 80% reflectance after aging for 180 minutes at 150 °C (302 °F)	"D6468"	No equivalent test
Pour Point	°C	6 °C (10°F) Minimum below ambient temperature	"D97"	"ISO 3016"
Sulfur	%mass	⁽³⁾	"D5453 or /D2622"	"ISO 20846" or "ISO 20884"
Kinematic Viscosity ⁽⁴⁾	"MM ² /S (cSt)"	The viscosity of the fuel that is delivered to the fuel injection pump. "1.4 minimum and /4.5 maximum"	"D445"	"ISO 3405"
Water and sediment	% weight	0.05% maximum	"D1796"	"ISO 3734"
Water	% weight	0.05% maximum	"D1744"	No equivalent test
Sediment	% weight	0.05% maximum	"D473"	"ISO 3735"
Gums and Resins ⁽⁵⁾	mg/100mL	10 mg per 100 mL maximum	"D381"	"ISO 6246"
Lubricity corrected wear scar diameter at 60 °C (140 °F). ⁽⁶⁾	mm	0.46 maximum	"D6079"	"ISO 12156-1"
Fuel cleanliness ⁽⁷⁾	-	"ISO"18/16/13	"7619"	"ISO 4406"

(1) In order to insure minimum cetane number of 40 a distillate diesel fuel should have minimum cetane index of 44 when ASTM D4737 test method is used. A fuel with a higher cetane number is recommended to operate at a higher altitude or in cold weather.

(2) Density range allowed includes summer and winter diesel fuel grades. Fuel density varies depending on the sulfur level where high sulfur fuels have higher densities. Some unblended alternative fuels have lower densities which are acceptable, if all the other properties meet this specification.

(3) Regional regulations, national regulations, or international regulations can require a fuel with a specific sulfur limit. Consult all applicable regulations before selecting a fuel for a given engine application. LSD fuel with less than 0.05 percent (≤ 500 ppm (mg/kg)) sulfur is recommended for use in these engine models. Diesel fuel with more than 0.05 percent (≥ 500 ppm (mg/kg)) sulphur can be used only where allowed by legislation. Fuel sulfur levels affect exhaust emissions. High sulfur fuels also increase the potential for corrosion of internal components. Fuel sulfur levels above 0.05% may significantly shorten the oil change interval. For additional information, refer to **General lubricant Information**.

(4) The values of the fuel viscosity are the values as the fuel is delivered to the fuel injection pumps. Fuel should also meet the minimum viscosity requirement and the fuel should meet the maximum viscosity requirements at 40 °C (104 °F) of either the "ASTM D445" test method or the "ISO 3104" test method. If a fuel with a low viscosity is used, cooling of the fuel may be required to maintain 1.4 cSt or greater viscosity at the fuel injection pump. Fuels with a high viscosity might require fuel heaters to lower the viscosity to 4.5 cSt at the fuel injection pump.

(5) Follow the test conditions and procedures for gasoline (motor).

(6) The lubricity of a fuel is a concern with low sulfur and ultra low sulfur fuel. To determine the lubricity of the fuel, use the "ISO 12156-1 or ASTM D6079 High Frequency Reciprocating Rig (HFRR)" test. If the lubricity of a fuel does not meet the minimum requirements, consult your fuel supplier. Do not treat the fuel without consulting the fuel supplier. Some additives are not compatible. These additives can cause problems in the fuel system.

(7) Recommended cleanliness level for fuel as dispensed into machine or engine fuel tank is "ISO 18/16/13 or cleaner as per ISO 4406. Refer to the "Contamination Control Recommendations for Fuels" in this chapter.

NOTICE

Operating with fuels that do not meet the Perkins recommendations can cause the following effects: Starting difficulty, poor combustion, deposits in the fuel injectors, reduced service life of the fuel system, deposits in the combustion chamber and reduced service life of the engine.

Engines that are manufactured by Perkins are certified with the fuel that is prescribed by the United States Environmental Protection Agency. Engines that are manufactured by Perkins are certified with the fuel that is prescribed by the European Certification and other regulatory agencies. Perkins does not certify diesel engines on any other fuel.

Note: The owner and the operator of the engine has the responsibility of using the fuel that is prescribed by the Environmental Protection Agency (EPA) and other appropriate regulatory agencies.

Diesel Fuel Characteristics

Perkins Recommendations

Cetane Number

Fuel that has a high cetane number will give a shorter ignition delay. A high cetane number will produce a better ignition quality. Cetane numbers are derived for fuels against proportions of cetane and heptamethylnonane in the standard CFR engine. Refer to "ISO 5165" for the test method.

Cetane numbers more than 45 are normally expected from current diesel fuel. However, a cetane number of 40 may be experienced in some territories. The United States of America is one of the territories that can have a low cetane value. A minimum cetane value of 40 is required during average starting conditions. A higher cetane value may be required for operations at high altitudes or in cold-weather operations.

Fuel with a low cetane number can be the root cause of problems during cold start.

Viscosity

Viscosity is the property of a liquid of offering resistance to shear or flow. Viscosity decreases with increasing temperature. This decrease in viscosity follows a logarithmic relationship for normal fossil fuel. The common reference is to kinematic viscosity. Kinematic viscosity is the quotient of the dynamic viscosity that is divided by the density. The determination of kinematic viscosity is normally by readings from gravity flow viscometers at standard temperatures. Refer to "ISO 3104" for the test method.

The viscosity of the fuel is significant because fuel serves as a lubricant for the fuel system components. Fuel must have sufficient viscosity to lubricate the fuel system in both cold temperatures and hot temperatures. If the kinematic viscosity of the fuel is lower than 1.4 cSt at the fuel injection pump, damage to the fuel injection pump can occur. This damage can be excessive scuffing and seizure. Low viscosity may lead to difficult hot restarting, stalling, and loss of performance. High viscosity may result in seizure of the pump.

Perkins recommends kinematic viscosities of 1.4 and 4.5 cSt that is delivered to the fuel injection pump. If a fuel with a low viscosity is used, cooling of the fuel may be required to maintain 1.4 cSt or greater viscosity at the fuel injection pump. Fuels with a high viscosity might require fuel heaters to lower the viscosity to 4.5 cSt at the fuel injection pump.

Density

Density is the mass of the fuel per unit volume at a specific temperature. This parameter has a direct influence on engine performance and a direct influence on emissions. This influence determines the heat output from a given injected volume of fuel. This parameter is quoted in the following kg/m³ at 15 °C (59 °F).

Perkins recommends a value of density of 841 kg/m³ to obtain the correct power output. Lighter fuels are acceptable but these fuels will not produce the rated power.

Sulfur

The level of sulfur is governed by emissions legislations. Regional regulation, national regulations, or international regulations can require a fuel with a specific sulfur limit. The sulfur content of the fuel and the fuel quality must comply with all existing local regulations for emissions.

LSD fuel with less than 0.05 percent (≤ 500 ppm (mg/kg)) sulfur is recommended for use in these engine models.

ULSD less than 0.0015% (≤ 15 PPM (mg/Kg)) sulphur is acceptable to use in these engine models. The lubricity of these fuels must not exceed wear scar diameter of 0.46 mm (0.01811 inch) as per "ISO 12156-1". Refer to "Lubricity" for more information.

Fuels with sulphur content higher than 0.05 percent (500 PPM) can be used where allowed by legislation.

Fuel with a high sulfur content can cause engine wear. High sulfur fuel will have a negative impact on emissions of particulates. High sulfur fuel can be used if the local emissions legislation will allow the use. High sulfur fuel can be used in countries that do not regulate emissions.

When only high sulfur fuels are available, high alkaline lubricating oil must be used in the engine. Alternatively, the lubricating oil change interval must be reduced. Refer to Operation and Maintenance Manual, "Fluid Recommendations (Lubricant Information)" for information on sulfur in fuel.

Lubricity

Lubricity is the capability of the fuel to prevent pump wear. The lubricity of the fluid describes the ability of the fluid to reduce the friction between surfaces that are under load. This ability reduces the damage that is caused by friction. Fuel injection systems rely on the lubricating properties of the fuel. Until fuel sulfur limits were mandated, the lubricity of the fuel was believed to be a function of fuel viscosity.

The lubricity has particular significance to the current low viscosity fuel, low sulfur fuel, and low aromatic fossil fuel. These fuels are made to meet stringent exhaust emissions.

The lubricity of these fuels must not exceed wear scar diameter of 0.46 mm (0.01811 inch). The fuel lubricity test must be performed on an HFRR, operated at 60 °C (140 °F). Refer to "ISO 12156-1".

NOTICE

The fuels system has been qualified with fuel having lubricity up to 0.46 mm (0.01811 inch) wear scar diameter as tested by "ISO 12156-1". Fuel with higher wear scar diameter than 0.46 mm (0.01811 inch) will lead to reduced service life and premature failure of the fuel system.

In the fuels which do not meet specified lubricity requirement appropriate lubricity additive can be used to enhance the lubricity of the fuel.

Perkins Diesel Fuel Conditioner U5MK8276 is the approved additive refer to section, Perkins Diesel Fuel Conditioner for more information.

Contact your fuel supplier for those circumstances when fuel additives are required. Your fuel supplier can make recommendations for additives to use and for the proper level of treatment.

Distillation

Distillation will give an indication of the mixture of different hydrocarbons in the fuel. A high ratio of lightweight hydrocarbons can affect the characteristics of combustion.

Classification of the Fuels

Diesel engines have an ability to burn wide variety of fuels. Below is a list of typically encountered fuel specifications that have been assessed as to their acceptability and are divided into following categories:

Group 1: Preferred Fuels

The following fuel specifications are considered acceptable.

- Fuels that meet the requirements that are listed in the table 5 .
- "IS 1460 Bharat Stage 2, 3 and 4"
- "EN590 - Grades A to F and class 0 to 4"
- "ASTM D975 Grade No. 1-D and 2-D"
- "JIS K2204 Grades 1, 2 & 3 & Special Grade 3" acceptable provided lubricity ware scar diameter does not exceed of 0.46 mm (0.01811 inch) as per "ISO 12156-1" .
- "BS2869 - Class A2 Off Highway Gas Oil, Red Diesel"

Note: The lubricity of these fuels must not exceed wear scar diameter of 0.46 mm (0.01811 inch) as per "ISO 12156-1" . Refer to "Lubricity".

Group 2: Aviation Kerosene Fuels

Following kerosene and jet fuel specifications are acceptable alternative fuels, and may be used on a contingency base for emergency or continuous use, where standard diesel fuel is not available and where legislation allows their use:

- "MIL-DTL-83133 NATO F34 (JP-8)"
- "MIL-DTL-83133 NATO F35"
- "MIL-DTL-5624 NATO F44 (JP-5)"
- "MIL-DTL-38219 (USAF) (JP7)"
- "NATO XF63"
- "ASTM D1655 JET A"
- "ASTM D1655 JET A1"

NOTICE

These fuels are only acceptable when used with appropriate lubricity additive and must meet minimum requirements that are listed in table 5 . The lubricity of these fuels must not exceed wear scar diameter of 0.46 mm (0.01811 inch) as per "ISO 12156-1" . Refer to "Lubricity" and Perkins Diesel Fuel Conditioner.

Note: Minimum cetane number of 40 is recommended otherwise cold starting problems or light load misfire might occur. Since jet fuel specifications do not mention cetane requirements, Perkins recommends that a fuel sample is taken to determine the cetane number.

Note: Fuels must have minimum viscosity of 1.4 cSt delivered to the fuel injection pump. Cooling of the fuel may be required to maintain 1.4 cSt or greater viscosity at the fuel injection pump. Perkins recommends that the actual viscosity of the fuel, be measured to determine if a fuel cooler is needed. Refer to “Viscosity”.

Note: Rated power loss of up to 10 percent is possible due to lower density and lower viscosity of jet fuels compared to diesel fuels.

Biodiesel Fuel

Biodiesel is a fuel that can be defined as mono-alkyl esters of fatty acids. Biodiesel is a fuel that can be made from various feedstock. The most commonly available biodiesel in Europe is Rape Methyl Ester (REM). This biodiesel is derived from rapeseed oil. Soy Methyl Ester (SME) is the most common biodiesel in the United States. This biodiesel is derived from soybean oil. Soybean oil or rapeseed oil are the primary feedstocks. These fuels are together known as Fatty Acid Methyl Esters (FAME).

Raw pressed vegetable oils are NOT acceptable for use as a fuel in any concentration in compression engines. Without esterification, these oils may gel in the crankcase and the fuel tank. These fuels may not be compatible with many of the elastomers that are used in engines that are manufactured today. In original forms, these oils are not suitable for use as a fuel in compression engines. Alternate base stocks for biodiesel may include animal tallow, waste cooking oils, or various other feedstocks. To use any of the products that are listed as fuel, the oil must be esterified.

Fuel made of 100 percent FAME is normally referred to as B100 biodiesel or neat biodiesel.

Biodiesel can be blended with distillate diesel fuel. The blends can be used as fuel. The most commonly available biodiesel blends are B5, which is 5 percent biodiesel and 95 percent distillate diesel fuel. B20, which is 20 percent biodiesel and 80 percent distillate diesel fuel.

Note: The percentages given are volume-based. The U.S. distillate diesel fuel specification “ASTM D975-09a” includes up to B5 (5 percent) biodiesel.

European distillate diesel fuel specification “EN590:2010” includes up to B7 (7 percent) biodiesel.

Note: Engines that are manufactured by Perkins are certified by use of the prescribed Environmental Protection Agency (EPA) and European Certification fuels. Perkins does not certify engines on any other fuel. The user of the engine has the responsibility of using the correct fuel that is recommended by the manufacturer and allowed by the EPA and other appropriate regulatory agencies.

Specification Requirements

The neat biodiesel must conform to “EN14214” or “ASTM D6751” (in the USA) and can only be blended in mixture of up to 20 percent, by volume in acceptable mineral diesel fuel meeting requirements that are listed in table 5 or the latest edition of “EN590” and “ASTM D 975” commercial standards. This blend is commonly known as B20.

Biodiesel blends are denoted as “BXX” with “XX” representing the content of neat biodiesel contained in the blend with mineral diesel fuel (for example B5, B10, B20).

In United States Biodiesel blends of B6 to B20 must meet the requirements listed in the latest edition of “ASTM D7467” (B6 to B20) and must be of an API gravity of 30-45.

In North America biodiesel and biodiesel blends must be purchased from the BQ-9000 accredited producers and BQ-9000 certified distributors.

In other areas of the world, the use of biodiesel that is BQ-9000 accredited and certified, or that is accredited and certified by a comparable biodiesel quality body to meet similar biodiesel quality standards is required.

Engine Service Requirements with B20

Aggressive properties of biodiesel fuel may cause debris in the fuel tank and fuel lines. The aggressive properties of biodiesel will clean the fuel tank and fuel lines. This cleaning of the fuel system can prematurely block of the fuel filters. Perkins recommends that after the initial usage of B20 biodiesel blended fuel the fuel filters must be replaced at 50 hours.

Glycerides present in biodiesel fuel will also cause fuel filters to become blocked more quickly. Therefore the regular service interval should be reduced to 250 hours.

When biodiesel fuel is used, crank case oil and aftertreatment systems (if installed) may be influenced. This influence is due to the chemical composition and characteristics of biodiesel fuel, such as density and volatility, and to chemical contaminants that can be present in this fuel, such as alkali and alkaline metals (sodium, potassium, calcium, and magnesium).

- Crankcase oil fuel dilution can be higher when biodiesel or biodiesel blends are used. This increased level of fuel dilution when using biodiesel or biodiesel blends is related to the typically lower volatility of biodiesel. In cylinder emissions control strategies utilized in many of the industrial latest engine designs may lead to a higher level of biodiesel concentration in the engine oil pan. The long-term effect of biodiesel concentration in crankcase oil is unknown.

- Perkins recommends the use of oil analysis to check the quality of the engine oil if biodiesel fuel is used. Ensure that the level of biodiesel in the fuel is noted when the oil sample is taken.

Performance Related Issues with B20

Due to the lower energy content than the standard distillate fuel B20 will cause a power loss in order of 2 to 4 percent. In addition, over time the power may deteriorate further due to deposits in the fuel injectors.

Biodiesel and biodiesel blends are known to cause an increase in fuel system deposits, most significant of which are deposits within the fuel injector.

Perkins Diesel Fuel Cleaner T400012 is most effective in cleaning and preventing the formation of deposits. Refer to section, Perkins Diesel Fuel System Cleaner for more information. Perkins Diesel Fuel Conditioner U5MK8276 helps to limit deposit issues by improving the stability of biodiesel while also hindering the production of new deposits. For more information refer to section, Perkins Diesel Fuel Conditioner. Therefore the use of Perkins Diesel Fuel Cleaner and or Perkins Diesel Fuel Conditioner is recommended when running biodiesel blends, especially B20.

Perkins T400012 Fuel Cleaner is most effective in cleaning and preventing the formation of deposits. Refer to “Perkins Diesel Fuel System Cleaner, and Perkins” for more information. Perkins U5MK8276 Perkins Diesel Fuel Conditioner helps to limit deposit issues by improving the stability of biodiesel while also hindering the production of new deposits. For more information refer to “Perkins Diesel Fuel Conditioner, and Perkins”. Therefore the use of Diesel Fuel Cleaner and or Diesel Fuel Conditioner is recommended when running biodiesel blends, especially B20.

General Requirements

Biodiesel has poor oxidation stability, which can result in long-term problems in the storage of biodiesel. Biodiesel fuel should be used within 6 months of manufacture. Equipment should not be stored with the B20 biodiesel blends in the fuel system for longer than 3 months.

Due to poor oxidation stability and other potential issues, Perkins recommends that engines with limited operational time either do not use biodiesel blends or, while accepting some risk, limit biodiesel blend to a maximum of B5. Examples of applications that should limit the use of biodiesel are the following: Standby generator sets and certain emergency vehicles.

For standby generator sets and emergency vehicles that cannot avoid use of biodiesel blends fuel quality in the engine fuel tank must be sampled and checked monthly. Test should include acid number (EN14104), oxidation stability (EN 15751 commonly know as the Rancimant test), and sediment (ISO12937). For standby generator sets oxidation stability of biodiesel blend must be 20 hours or more as per EN 15751. If the test shows that the fuel has degraded, fuel tank must be drained and engine flashed by running with the fresh high-quality diesel fuel.

For standby generator sets and emergency vehicles that cannot avoid use of biodiesel blends fuel quality in the engine fuel tank must be sampled and checked monthly. Test should include acid number (EN14104), oxidation stability (EN 15751 commonly know as the Rancimant test), and sediment (ISO12937). For standby generator sets oxidation stability of biodiesel blend must be 20 hours or more as per EN 15751. If the test shows that the fuel has degraded, fuel tank must be drained and engine flashed by running with fresh high-quality diesel fuel.

Perkins strongly recommends that seasonally operated engines have the fuel systems, including fuel tanks, flashed with conventional diesel fuel before prolonged shutdown periods. An example of an application that should seasonally flush the fuel system is a combine harvester.

Microbial contamination and growth can cause corrosion in the fuel system and premature plugging of the fuel filter. Consult your supplier of fuel for assistance in selecting appropriate antimicrobial additive.

Water accelerates microbial contamination and growth. When biodiesel is compared to distillate fuels, water is naturally more likely to exist in the biodiesel. Frequent checks are therefore essential and if necessary, drain the water separator.

Materials such as brass, bronze, copper, lead, tin, and zinc accelerate the oxidation process of the biodiesel fuel. The oxidation process can cause deposits formation therefore these materials must not be used for fuel tanks and fuel lines.

Fuel for Cold-Weather Operation

The European standard “EN590” contains climate dependant requirements and a range of options. The options can be applied differently in each country. There are five classes that are given to arctic climates and severe winter climates. 0, 1, 2, 3 and 4.

Fuel that complies with “EN590” CLASS 4 can be used at temperatures as low as $-44\text{ }^{\circ}\text{C}$ ($-47.2\text{ }^{\circ}\text{F}$). Refer to “EN590” for a detailed discretion of the physical properties of the fuel.

The diesel fuel “ASTM D975 1-D” that is used in the United States of America may be used in cold temperatures that are below $-18\text{ }^{\circ}\text{C}$ ($-0.4\text{ }^{\circ}\text{F}$).

In extreme cold ambient conditions, you may use the aviation kerosene fuels that are specified in Group 2. These fuels are intended to be used in temperatures that can be as low as $-54\text{ }^{\circ}\text{C}$ ($-65.2\text{ }^{\circ}\text{F}$). Refer to Group 2 for detail and conditions of use of the aviation kerosene fuels.

WARNING

Mixing alcohol or gasoline with diesel fuel can produce an explosive mixture in the engine crankcase or the fuel tank. Alcohol or gasoline must not be used in order to dilute diesel fuel. Failure to follow this instruction may result in death or personal injury.

There are many other diesel fuel specifications that are published by governments and by technological societies. Usually, those specifications do not review all the requirements that are addressed in table 5 . To ensure optimum engine performance, a complete fuel analysis should be obtained before engine operation. The fuel analysis should include all the properties that are stated in the table 5 .

Aftermarket Fuel Additives

NOTICE

Perkins does not warrant the quality or performance of non-Perkins fluids and filters.

When auxiliary devices, accessories, or consumables (filters, additives) which are made by other manufacturers are used on Perkins products, the Perkins warranty is not affected simply because of such use.

However, failures that result from the installation or use of other manufacturers devices, accessories, or consumables are NOT Perkins defects. Therefore, the defects are NOT covered under the Perkins warranty.

Supplemental diesel fuel additives are not generally recommended. This recommendation is due to potential damage to the fuel system or the engine.

Perkins recognizes the fact that additives may be required in some special circumstances. Fuel additives must be used with caution. Contact your fuel supplier for those circumstances when fuel additives are required. Your fuel supplier can recommend the appropriate fuel additive and the correct level of treatment.

Note: For the best results, your fuel supplier should treat the fuel when additives are required. The treated fuel must meet the requirements that are stated in table 5 .

Perkins Diesel Fuel System Cleaner

Perkins T400012 Fuel Cleaner is the only fuel cleaner that is recommended by Perkins.

Perkins Diesel Fuel Cleaner (part number T400012) is the only fuel cleaner that is recommended by Perkins.

If biodiesel or biodiesel blends of fuel are to be used, Perkins require the use of Perkins fuel cleaner. For more information on the use of biodiesel and biodiesel blends refer to "Biodiesel Fuel".

Perkins fuel cleaner will remove deposits that can form in the fuel system with the use of biodiesel and biodiesel blends. These deposits can create a loss of power and engine performance.

Once the fuel cleaner has been added to the fuel, the deposits within the fuel system are removed after 30 hours of engine operation. For maximum results, continue to use the fuel cleaner for up to 80 hours. Perkins fuel cleaner can be used on an on-going basis with no adverse impact on engine or fuel system durability.

Detailed instructions on the rate of which the fuel cleaner must be use are on the container.

Perkins Diesel Fuel Conditioner

Perkins Diesel Fuel Conditioner (part number U5MK8276) can be used in these engine models. The diesel fuel conditioner is a proprietary metal and ash free formulation that has been extensively tested for use with distillate diesel fuels for use in Perkins diesel engines. The diesel fuel conditioner helps address many of the challenges that various fuels worldwide present with regard to fuel life/stability, engine startability, injector deposits, fuel system life, and long-term engine performance. Contact a Perkins distributor for more information.

Note: Diesel fuel additives/conditioners may not improve markedly poor diesel fuel properties enough to make poor diesel acceptable for use.

Diesel fuel conditioner is a proven high performance, multipurpose diesel fuel conditioner that is designed to improve:

- Fuel economy (through fuel system clean-up)
- Lubricity
- Oxidation stability
- Detergency/dispersancy
- Moisture dispersancy
- Corrosion protection
- Cetane (typically 2-3 cetane numbers)

The diesel fuel conditioner also reduces the formation of gums, resins, and sludge, and disperses insoluble gums.

For maximum overall benefits, ask your fuel supplier to add the fuel conditioner at the recommended treat rate before fuel delivery. Or you may add the fuel conditioner at the recommended treat rate during the early weeks of fuel storage.

Contamination Control Recommendations for Fuels

Fuels of “ISO 18/16/13” cleanliness level or cleaner as dispensed into the engine or application fuel tank should be used. This standard will reduce risk of power loss, fuel system failures, and related downtime of engines. This cleanliness level is important for unit injector fuel system. The fuel system utilizes higher fuel injection pressures and have tight clearances between moving parts to meet required stringent emissions regulations. As a result, particle contaminants as small as 4 µm can cause scoring and scratching of internal pump and injector surfaces and of injector nozzles.

Water in the fuel causes cavitation, corrosion of fuel system parts, and provides an environment where microbial growth in the fuel can flourish. Other sources of fuel contamination are soaps, gels, or other compounds that may result from undesirable chemical interactions in the fuels, particularly in ULSD. Gels and other compounds can also form in biodiesel fuel at low temperatures or if biodiesel is stored for extended periods. The best indication of microbial contamination, fuel additives, or cold temperature gel is rapid filter plugging of bulk fuel filters or application fuel filters.

To reduce downtime due to contamination, follow these fuel maintenance guidelines.

- Use high-quality fuels per recommended and required specifications
- Fill fuel tanks with fuels of “ISO 18/16/13” cleanliness level or cleaner, in particular for engines with common rail and unit injection systems. When you refuel the tank, filter the fuel through a 4 µm absolute filter (Beta 4 = 75 up to 200) in order to reach the recommended cleanliness level. This filtration should be located at the device that dispenses the fuel to the fuel tank. In addition, filtration at the dispensing point should remove water to ensure that fuel is dispensed at 500 ppm water or less.
- Perkins recommends the use of bulk fuel filter / coalescer units which clean the fuel of both particulate contamination and water in a single pass.
- Ensure that you use Perkins Advanced Efficiency Fuel Filters. Change your fuel filters per recommended service requirements or as needed.
- Drain your water separators daily.

- Drain your fuel tanks of sediment and water per the Operation and Maintenance Manual instructions.
- Install and maintain a properly designed bulk filter / coalescer filtration system. Continuous bulk filtration systems may be required to ensure that dispensed fuel meets the cleanliness target. Consult your Perkins distributor for availability of bulk filtration products.
- Centrifugal filters may need to be used as a pre-filter with fuel that is severely contaminated with gross amounts of water and/or large particulate contaminants. Centrifugal filters can effectively remove large contaminants. Centrifugal filters may not be able to remove the small abrasive particles required to achieve the recommended “ISO” cleanliness level. Bulk filter / coalescers are necessary as a final filter to achieve the recommended cleanliness level.
- Install desiccant type breathers of 4 µm or less absolute efficiency with the ability to remove water on bulk storage tanks.
- Follow proper practices of fuel transportation. Filtration from the storage tank to the application promotes the delivery of clean fuel. Fuel filtration can be installed at each transport stage to keep the fuel clean.
- Cover, protect, and ensure cleanliness of all connection hoses, fittings, and dispensing nozzles.

Consult your local Perkins distributor for additional information on Perkins designed and produced filtration products.

Renewable and Alternative Fuels

Perkins supports development and use of renewable fuels through sustainability initiatives. In recent years various forms of renewable and alternative (synthetic) diesel fuels have started to emerge.

Synthetic diesel fuels are produced by gasification of various feedstock and then synthesis to liquid to obtain paraffinic diesel fuel. Based on the feedstock used these fuels are commonly referred to as Biomass to liquid (BTL), Gas to liquid (GTL) and Coal to liquid (CTL). Hydrotreating of vegetable oils and animal fats is another emerging process for production of bio based diesel fuel called Hydrotreated Vegetable Oil (HVO).

BTL and HVO fuels are considered to be low carbon fuels as they reduce carbon footprint compared to fossil fuels and are commonly referred to as renewable fuels. These fuels must not be confused with biodiesel FAME which is fundamentally different fuel and is discussed in a separate section in this manual.

These paraffinic fuels have virtually no sulphur or aromatics and have very high cetane numbers which enable very clean burning and efficient engine operation. Chemically these fuels are similar to diesel fuel derived from petroleum and are therefore suitable to use in diesel engines as a replacement or blend stock with conventional diesel fuel. To be acceptable renewable and alternative fuels must meet latest edition of the paraffinic diesel fuel specification "CENTS 15940". The fuel should also meet requirements described in table 5, Perkins Specification for Distillate Diesel Fuel, EN590, or latest ASTM D975 specification.

Ensure that the fuel has got appropriate cold flow properties (cloud point and CFPP) for the minimum statistical ambient temperature the engine is expected to see in the operation. The Fuel must also meet lubricity requirements as specified in the lubricity section of this "Operation and Maintenance Manual" Fluid Recommendations

i07675883

Fluid Recommendations

General Coolant Information

NOTICE

Never add coolant to an overheated engine. Engine damage could result. Allow the engine to cool first.

NOTICE

If the engine is to be stored in, or shipped to an area with below freezing temperatures, the cooling system must be either protected to the lowest outside temperature or drained completely to prevent damage.

NOTICE

Frequently check the specific gravity of the coolant for proper freeze protection or for anti-boil protection.

Clean the cooling system for the following reasons:

- Contamination of the cooling system
- Overheating of the engine
- Foaming of the coolant

NOTICE

Never operate an engine without water temperature regulators in the cooling system. Water temperature regulators help to maintain the engine coolant at the proper operating temperature. Cooling system problems can develop without water temperature regulators.

Many engine failures are related to the cooling system. The following problems are related to cooling system failures: Overheating, leakage of the water pump and plugged radiators or heat exchangers.

These failures can be avoided with correct cooling system maintenance. Cooling system maintenance is as important as maintenance of the fuel system and the lubrication system. Quality of the coolant is as important as the quality of the fuel and the lubricating oil.

Coolant is normally composed of three elements: Water, additives, and glycol.

Water

Water is used in the cooling system to transfer heat.

Note: The water must be used with an inhibitor to protect the engine.

Distilled water or deionized water is recommended for use in engine cooling systems.

DO NOT use the following types of water in cooling systems: Hard water, softened water that has been conditioned with salt and sea water.

If distilled water or deionized water is not available, use water with the properties that are listed in Table 6

Table 6

Acceptable Water	
Property	Maximum Limit
Chloride (Cl)	40 mg/L
Sulfate (SO ₄)	100 mg/L
Total Hardness	170 mg/L
Total Solids	340 mg/L
Acidity	pH of 5.5 to 9.0

For a water analysis, consult one of the following sources:

- Local water utility company
- Agricultural agent
- Independent laboratory

Additives

Additives help to protect the metal surfaces of the cooling system. A lack of coolant additives or insufficient amounts of additives enable the following conditions to occur:

- Corrosion
- Formation of mineral deposits

- Rust
- Scale
- Foaming of the coolant

Many additives are depleted during engine operation. These additives must be replaced periodically.

Additives must be added at the correct concentration. Over concentration of additives can cause the inhibitors to drop out-of-solution. The deposits can enable the following problems to occur:

- Formation of gel compounds
- Reduction of heat transfer
- Leakage of the water pump seal
- Plugging of radiators, coolers, and small passages

Glycol

Glycol in the coolant helps to provide protection against the following conditions:

- Boiling
- Freezing
- Cavitation of the water pump

For optimum performance, Perkins recommends a 1:1 mixture of a water/glycol solution.

Note: Use a mixture that will provide protection against the lowest ambient temperature.

Note: 100 percent pure glycol will freeze at a temperature of -13 °C (8.6 °F).

Most conventional antifreezes use ethylene glycol. Propylene glycol may also be used. In a 1:1 mixture with water, ethylene and propylene glycol provide similar protection against freezing and boiling. Refer to Table 7 and refer to table 8 .

Table 7

Ethylene Glycol	
Concentration	Freeze Protection
50 Percent	-36 °C (-33 °F)
60 Percent	-51 °C (-60 °F)

NOTICE

Do not use propylene glycol in concentrations that exceed 50 percent glycol because of the reduced heat transfer capability of propylene glycol. Use ethylene glycol in conditions that require additional protection against boiling or freezing.

Table 8

Propylene Glycol	
Concentration	Freeze Protection
50 Percent	-29 °C (-20 °F)

To check the concentration of glycol in the coolant, measure the specific gravity of the coolant.

Note: Some commercially available coolants are based on alternative fluids, such as 1, 3-propanediol (beta-propylene glycol, PDO), glycerin (glycerol) or mixtures of these alternatives with ethylene/propylene glycols. At the time of publication of this document no industry standard exists for coolants based on these chemicals. Until such standard/specifications are published and evaluated by Perkins, use of PDO, glycerine or other alternative coolants is not recommended in Perkins diesel engines.

Coolant Recommendations

- ELC _____ Extended Life Coolant
- SCA _____ Supplement Coolant Additive
- ASTM _____ American Society for Testing and Materials

ELC - extended life coolant. A coolant that relies on organic inhibitors for corrosion and cavitation protection. Also called OAT coolant (Organic Acid Technology).

SCA - supplemental coolant additive, concentrated inorganic inhibitor package.

Extender - concentrated organic inhibitor package.

Conventional Coolant - a coolant that relies on inorganic inhibitors for corrosion and cavitation protection.

Hybrid Coolant - a coolant in which the corrosion and cavitation protection is based on a mixture of organic and inorganic inhibitors.

The following coolants are recommended for used in Perkins diesel engines:

Preferred – Perkins ELC

Acceptable – A commercial heavy-duty antifreeze that meets “ASTM D6210” or “ASTM D4985” specifications.

NOTICE

The Perkins industrial engines with a NOx reduction system must be operated with a minimum 30% volume glycol-water mixture, Perkins recommends 50% volume glycol-water mixture of water and glycol. The 50% concentration allows the NOx reduction system to operate correctly at high ambient temperatures.

NOTICE

Do not use a commercial coolant/antifreeze that only meets the ASTM D3306 specification. This type of coolant/antifreeze is made for light automotive applications.

Perkins recommends a 50% mixture of water and glycol. This mixture of water and glycol will provide optimum heavy-duty performance as an antifreeze. This ratio may be changed to 40% water to 60% glycol if extra freezing protection is required.

A mixture of SCA inhibitor and water is acceptable but will not give the same level of corrosion, boiling and, freezing protection as ELC. Perkins recommends a 6 percent to 8 percent concentration of SCA in those cooling systems. Distilled water or deionized water is preferred.

Table 9

Coolant Service Life	
Coolant Type	Service Life ⁽¹⁾
Perkins ELC	6,000 Service Hours or Three Years
Commercial Heavy-Duty Antifreeze that meets "ASTM D6210"	3000 Service Hours or Two Year
Commercial SCA inhibitor and Water	3000 Service Hours or One Year

⁽¹⁾ Use the interval that occurs first. The cooling system must also be flushed out at this time.

Perkins ELC

Perkins provides ELC for use in the following applications:

- Heavy-duty spark ignited gas engines
- Heavy-duty diesel engines
- Automotive applications

The anti-corrosion package for ELC is different from the anti-corrosion package for other coolants. ELC is an ethylene glycol base coolant. However, ELC contains organic corrosion inhibitors and antifoam agents with low amounts of nitrite. Perkins ELC has been formulated with the correct amount of these additives to provide superior corrosion protection for all metals in engine cooling systems.

ELC is available in a premixed cooling solution with distilled water. ELC is a 1:1 mixture. The Premixed ELC provides freeze protection to -36°C (-33°F). The Premixed ELC is recommended for the initial fill of the cooling system. The Premixed ELC is also recommended for topping off the cooling system.

Containers of several sizes are available. Consult your Perkins distributor for the part numbers.

ELC Cooling System Maintenance**Correct additions to the Extended Life Coolant****NOTICE**

Use only Perkins products for pre-mixed coolants.

Mixing Extended Life Coolant with other products reduces the Extended Life Coolant service life. Failure to follow the recommendations can reduce cooling system components life unless appropriate corrective action is performed.

To maintain the correct balance between the antifreeze and the additives, you must maintain the recommended concentration of ELC. Lowering the proportion of antifreeze lowers the proportion of additive. Lowering the ability of the coolant to protect the system will form pitting, from cavitation, from erosion, and from deposits.

NOTICE

Do not use a conventional coolant to top-off a cooling system that is filled with Extended Life Coolant (ELC).

Do not use supplemental coolant additive (SCA).

ELC Cooling System Cleaning

Note: If the cooling system is already using ELC, cleaning agents are not required to be used at the specified coolant change interval. Cleaning agents are only required if the system has been contaminated by the addition of some other type of coolant or by cooling system damage.

Clean water is the only cleaning agent that is required when ELC is drained from the cooling system.

Before the cooling system is filled, the heater control (if equipped) must be set to the HOT position. Refer to the OEM to set the heater control. After the cooling system is drained and the cooling system is refilled, operate the engine until the coolant level reaches the normal operating temperature and until the coolant level stabilizes. As needed, add the coolant mixture to fill the system to the specified level.

Changing to Perkins ELC

To change from heavy-duty antifreeze to the Perkins ELC, perform the following steps:

NOTICE

Care must be taken to ensure that all fluids are contained during performance of inspection, maintenance, testing, adjusting and the repair of the product. Be prepared to collect the fluid with suitable containers before opening any compartment or disassembling any component containing fluids.

Dispose of all fluids according to local regulations and mandates.

1. Drain the coolant into a suitable container.
2. Dispose of the coolant according to local regulations.
3. Fill the cooling system with a 33 percent solution of Perkins ELC and operate the engine, ensure that the thermostat opens. Stop the engine and allow the engine to cool. Drain the coolant.

Note: Use distilled or deionized water in the solution.

4. Again, fill the cooling system with a 33 percent solution of Perkins ELC and operate the engine ensure that the thermostat opens. Stop the engine and allow to cool.
 5. Drain the cooling system.
-

NOTICE

Incorrect or incomplete flushing of the cooling system can result in damage to copper and other metal components.

NOTICE

Most commercial cooling system cleaning agents are corrosive and their use is not recommended by Perkins.

6. Fill the cooling system with the Perkins Premixed ELC. Operate the engine. Ensure that all coolant valves open then stop the engine. When cool check the coolant level.

ELC Cooling System Contamination

NOTICE

Mixing ELC with other products reduces the effectiveness of the ELC and shortens the ELC service life. Failure to follow these recommendations can result in shortened cooling system component life.

ELC cooling systems can withstand contamination to a maximum of 10 percent of conventional heavy-duty antifreeze or SCA. If the contamination exceeds 10 percent of the total system capacity, perform ONE of the following procedures:

- Drain the cooling system into a suitable container. Dispose of the coolant according to local regulations. Flush the system with a 5 to 10 percent solution of Perkins ELC. Fill the system with the Perkins ELC.
- Maintain the system as a conventional Heavy-Duty Coolant. Treat the system with an SCA. Change the coolant at the interval that is recommended for the conventional Heavy-Duty Coolant.

Commercial Heavy-Duty Antifreeze and SCA

NOTICE

Commercial Heavy-Duty Coolant which contains Amines as part of the corrosion protection system must not be used.

NOTICE

Never operate an engine without water temperature regulators in the cooling system. Water temperature regulators help to maintain the engine coolant at the correct operating temperature. Cooling system problems can develop without water temperature regulators.

Check the glycol concentration to ensure adequate protection against boiling or freezing. Perkins recommends the use of a refractometer for checking the glycol concentration. A hydrometer should not be used.

Perkins engine cooling systems should be tested at 500 hour intervals for the concentration of SCA.

Additions of SCA are based on the results of the test. An SCA that is liquid may be needed at 500 hour intervals.

NOTICE

Do not mix types and brands of coolant.

Do not mix brands and types of SCAs.

Do not mix SCAs and Extenders.

Only use SCAs or Extender approved by coolant manufacturer and compatible with coolant.

Adding the SCA to Heavy-Duty Coolant at the Initial Fill

Coolants conforming to ASTM D4985 and not conforming D6210 require the addition of SCA at initial fill.

Use the equation that is in Table 10 to determine the amount of SCA that is required when the cooling system is initially filled.

Table 10

Equation For Adding The SCA To The Heavy-Duty Coolant At The Initial Fill
$V \times 0.07 = X$
V is the total volume of the cooling system.
X is the amount of SCA that is required.

Table 11 is an example for using the equation that is in Table 10 .

Table 11

Example Of The Equation For Adding The SCA To The Heavy-Duty Coolant At The Initial Fill		
Total Volume of the Cooling System (V)	Multiplication Factor	Amount of SCA that is Required (X)
15 L (4 US gal)	× 0.07	1.05 L (35.5 oz)

Adding The SCA to The Heavy-Duty Coolant For Maintenance

Heavy-duty antifreeze of all types REQUIRE periodic additions of an SCA.

Test the antifreeze periodically for the concentration of SCA. For the interval, refer to the Operation and Maintenance Manual, “Maintenance Interval Schedule” (Maintenance Section). Cooling System Supplemental Coolant Additive (SCA) Test/Add.

Additions of SCA are based on the results of the test. The size of the cooling system determines the amount of SCA that is needed.

Use the equation that is in Table 12 to determine the amount of SCA that is required, if necessary:

Table 12

Equation For Adding The SCA To The Heavy-Duty Coolant For Maintenance
$V \times 0.023 = X$
V is the total volume of the cooling system.
X is the amount of SCA that is required.

Table 13 is an example for using the equation that is in Table 12 .

Table 13

Example Of The Equation For Adding The SCA To The Heavy-Duty Coolant For Maintenance		
Total Volume of the Cooling System (V)	Multiplication Factor	Amount of SCA that is Required (X)
15 L (4 US gal)	× 0.023	0.35 L (11.7 oz)

Cleaning the System of Heavy-Duty Antifreeze

Note: Before corrosion inhibitors can be effective the cooling system must be free from rust, scale and deposits.

- Drain the cooling system.
- Before filling the cooling system with acceptable quality water, pre-dissolve the cleaning agent in the water. Use a non-foaming detergent to clean oil contamination, consult your Perkins dealer for suitable product.

NOTICE

Most commercial cooling system cleaning agents are corrosive and their use is not recommended by Perkins.

The cooling system must be thoroughly flushed with clean water after using cleaning agents.

Cleaning agents for marine or industrial cooling system must not be used, these are very aggressive and can cause damage to cooling system components.

- Run the engine for approximately 30 minutes and then leave the engine to cool down.
- Take a sample of the solution from the cooling system, drain the system.
- Allow the sample to sit for at least 30 minutes and check for signs of oil and deposits. If oil and deposits are still present repeat the procedure.
- Flush the system with clean water.
- Fill the system with new coolant.

Maintenance Recommendations

i08186078

System Pressure Release

Coolant System

WARNING

Pressurized system: Hot coolant can cause serious burn. To open cap, stop engine, wait until radiator is cool. Then loosen cap slowly to relieve the pressure.

To relieve the pressure from the coolant system, turn off the engine. Allow the cooling system pressure cap to cool. Remove the cooling system pressure cap slowly to relieve pressure.

Fuel System

To relieve the pressure from the fuel system, turn off the engine.

High-Pressure Fuel Lines (If Equipped)

WARNING

Contact with high pressure fuel may cause fluid penetration and burn hazards. High pressure fuel spray may cause a fire hazard. Failure to follow these inspection, maintenance and service instructions may cause personal injury or death.

The high-pressure fuel lines are between the high-pressure fuel pump and the high-pressure fuel manifold. The high-pressure fuel lines are also between the fuel manifold and cylinder head. These fuel lines are different from fuel lines on other fuel systems.

The following are the differences:

- The high-pressure fuel lines are constantly charged with high pressure.
- The internal pressures of the high-pressure fuel lines are higher than other types of fuel system.

Before any service or repair is performed on the engine fuel lines, perform the following tasks:

1. Stop the engine.
2. Wait for 10 minutes.

Do not loosen the high-pressure fuel lines to remove air pressure from the fuel system.

Engine Oil

To relieve pressure from the lubricating system, turn off the engine.

i06221218

Welding on Engines with Electronic Controls

NOTICE

Because the strength of the frame may decrease, some manufacturers do not recommend welding onto a chassis frame or rail. Consult the OEM of the equipment or your Perkins dealer regarding welding on a chassis frame or rail.

Correct welding procedures are necessary in order to avoid damage to the engines ECM, sensors, and associated components. When possible, remove the component from the unit and then weld the component. If removal of the component is not possible, the following procedure must be followed when you weld on a unit equipped with an Electronic Engine. The following procedure is considered to be the safest procedure to weld on a component. This procedure should provide a minimum risk of damage to electronic components.

NOTICE

Do not ground the welder to electrical components such as the ECM or sensors. Improper grounding can cause damage to the drive train bearings, hydraulic components, electrical components, and other components.

Clamp the ground cable from the welder to the component that will be welded. Place the clamp as close as possible to the weld. This will help reduce the possibility of damage.

Note: Perform the welding in areas that are free from explosive hazards.

1. Stop the engine. Turn the switched power to the OFF position.
2. Ensure that the fuel supply to the engine is turned off.
3. Disconnect the negative battery cable from the battery. If a battery disconnect switch is provided, open the switch.
4. Disconnect all electronic components from the wiring harnesses. Include the following components:

Maintenance Section
Severe Service Application

- Electronic components for the driven equipment
- ECM
- Sensors
- Electric operated fuel pump
- Electronically controlled valves
- Relays

NOTICE

Do not use electrical components (ECM or ECM sensors) or electronic component grounding points for grounding the welder.

5. Connect the welding ground cable directly to the part that will be welded. Place the ground cable as close as possible to the weld in order to reduce the possibility of welding current damage to the following components. Bearings, hydraulic components, electrical components, and ground straps.

Note: If electrical/electronic components are used as a ground for the welder or are located between the welder ground and the weld, current flow from the welder could severely damage the component.

6. Protect the wiring harness from welding debris and spatter.
7. Use standard welding practices to weld the materials.

i06221219

Severe Service Application

Severe service is the application of an engine that exceeds the current published standards for that engine. Perkins maintains standards for the following engine parameters:

- Performance such as power range, speed range, and fuel consumption
- Fuel quality
- Operational Altitude
- Maintenance intervals
- Oil selection and maintenance
- Coolant type and maintenance
- Environmental qualities
- Installation
- The temperature of the fluid in the engine

Refer to the standards for the engine or consult a Perkins dealer or distributor to determine if the engine is operating within the defined parameters.

Severe service operation can accelerate component wear. Engines that operate under severe conditions may need more frequent maintenance intervals in order to ensure maximum reliability and retention of full service life.

Due to individual applications, identification of all of the factors which can contribute to severe service operation is impossible. Consult a Perkins dealer or distributor for the unique maintenance that is necessary for the engine.

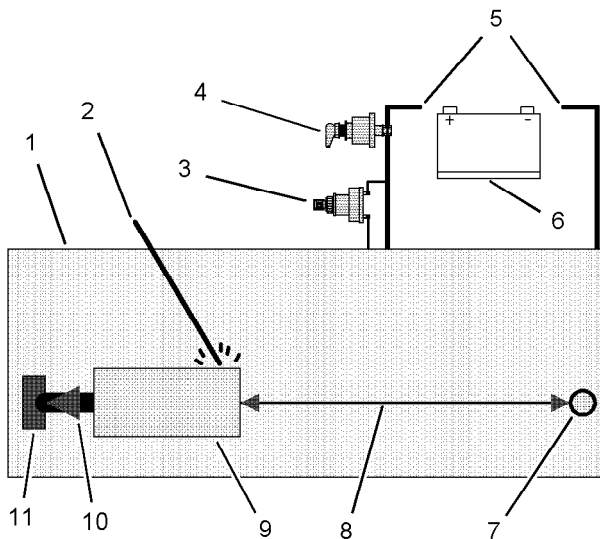

Illustration 29

g01075639

Use the example above. The current flow from the welder to the ground clamp of the welder will not damage any associated components.

- (1) Engine
- (2) Welding electrode
- (3) Keyswitch in the OFF position
- (4) Battery disconnect switch in the open position
- (5) Disconnected battery cables
- (6) Battery
- (7) Electrical/Electronic component
- (8) Minimum distance between the component that is being welded and any electrical/electronic component
- (9) The component that is being welded
- (10) Current path of the welder
- (11) Ground clamp for the welder

The operating environment, incorrect operating procedures, and incorrect maintenance procedures can be factors which contribute to a severe service application.

Environmental Factors

Ambient temperatures – The engine may be exposed to extended operation in extremely cold or hot environments. Valve components can be damaged by carbon buildup if the engine is frequently started and stopped in very cold temperatures. Extremely hot intake air reduces engine performance.

Quality of the air – The engine may be exposed to extended operation in an environment that is dirty or dusty, unless the equipment is cleaned regularly. Mud, dirt, and dust can encase components. Maintenance can be very difficult. The buildup can contain corrosive chemicals.

Buildup – Compounds, elements, corrosive chemicals, and salt can damage some components.

Altitude – Problems can arise when the engine is operated at altitudes that are higher than the intended settings for that application. Necessary adjustments should be made.

Incorrect Operating Procedures

- Extended operation at low idle
- Frequent hot shutdowns
- Operating at excessive loads
- Operating at excessive speeds
- Operating outside the intended application

Incorrect Maintenance Procedures

- Extending the maintenance intervals
- Failure to use recommended fuel, lubricants, and coolant/antifreeze

i07124141

Maintenance Interval Schedule

When Required

“ Battery - Recycle”	62
“ Battery - Replace”	62
“ Battery or Battery Cable - Disconnect”	63
“ Engine Air Cleaner Element (Dual Element) - Inspect/Clean/Replace”	70
“ Engine Air Cleaner Element (Single Element) - Inspect/Clean/Replace”	72
“ Fuel System - Prime”	78
“ Fuel Tank Water and Sediment - Drain”	82
“ Radiator - Clean”	

Daily

“ Air Tank Moisture and Sediment - Drain”	62
“ Coolant Level - Check”	67
“ Driven Equipment - Check”	69
“ Engine Air Cleaner Service Indicator - Inspect”	73
“ Engine Oil Level - Check”	74
“ Fuel Tank Water and Sediment - Drain”	82
“ Fuel System Primary Filter/Water Separator - Drain”	81
“ Power Take-Off Clutch - Check”	85
“Walk-Around Inspection”	86

Every 500 Service Hours

“ Belts - Inspect/Adjust/Replace”	64
“ Engine Air Cleaner Element (Dual Element) - Inspect/Clean/Replace”	70
“ Engine Air Cleaner Element (Single Element) - Inspect/Clean/Replace”	72
“ Engine Oil Sample - Obtain”	75
“ Engine Oil and Filter - Change”	75

Every 500 Service Hours or 1 Year

“ Battery Electrolyte Level - Check”	63
--------------------------------------	----

“ Cooling System Supplemental Coolant Additive (SCA) - Test/Add”	68
“ Fuel System Primary Filter (Water Separator) Element - Replace”	80
“ Fuel System Secondary Filter - Replace”	81
“Grounding Stud - Inspect/Clean/Tighten”	83
“ Hoses and Clamps - Inspect/Replace”	83
“ Starting Motor - Inspect”	85
“ Water Pump - Inspect”	86

Every 2500 Service Hours

“ Coolant Temperature Regulator - Replace”	68
“ Electronic Unit Injector - Check/Replace”	69
“ Engine Mounts - Inspect”	
“ Engine Valve Lash - Check”	
“ Engine Valve Rotators - Inspect”	78

Every 3000 Service Hours or 2 Years

“ Coolant (DEAC) - Change”	64
----------------------------	----

Every 4000 Service Hours

“ Air Compressor - Check”	
---------------------------	--

Every 6000 Service Hours or 3 Years

“ Coolant Extender (ELC) - Add”	67
---------------------------------	----

Every 585,000 L (154,540 US gal) of Fuel

“ Overhaul Considerations”	84
----------------------------	----

Every 12 000 Service Hours or 6 Years

“ Coolant (ELC) - Change”	66
---------------------------	----

i07192902

Air Compressor - Check (If Equipped)

WARNING

Do not disconnect the air line from the air compressor governor without purging the air brake and the auxiliary air systems. Failure to purge the air brake and the auxiliary air systems before removing the air compressor and/or the air lines could cause personal injury.

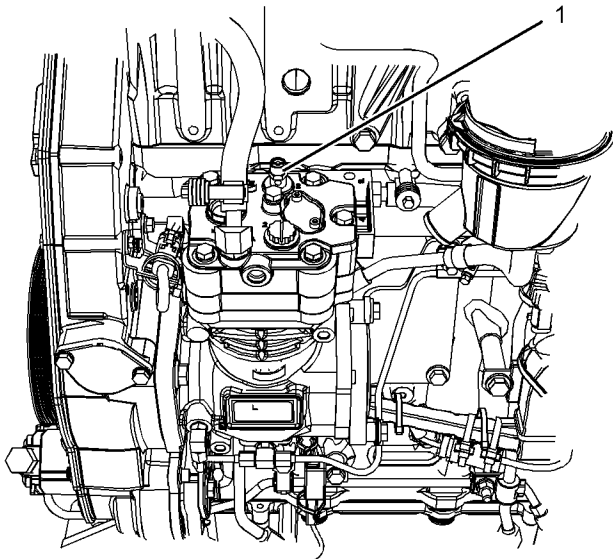

Illustration 30

g03813903

Typical example

(1) Pressure relief valve on single cylinder air compressor

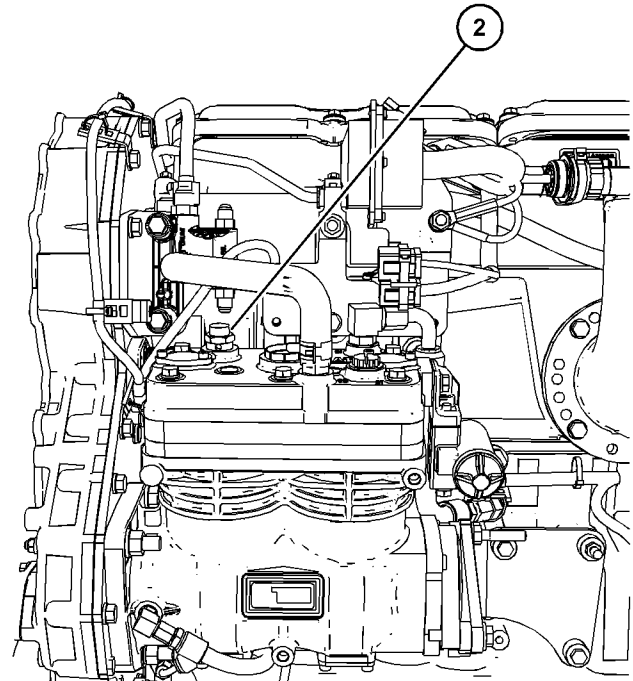

Illustration 31

g06248388

Typical example

(2) Pressure relief valve on twin cylinder air compressor

WARNING

If the air compressor pressure relief valve that is mounted in the air compressor cylinder head is bypassing compressed air, there is a malfunction in the air system, possibly ice blockage. Under these conditions, your engine may have insufficient air for normal brake operation.

Do not operate the engine until the reason for the air bypass is identified and corrected. Failure to heed this warning could lead to property damage, personal injury, or death to the operator or bystanders.

The function of the pressure relief valve is to bypass air when there is a malfunction in the system for the air compressor.

The pressure relief valve for the air compressor releases air at 1723 kPa (250 psi). If the pressure relief valve for the air compressor exhausts, all personnel should be at a safe distance away from the air compressor. All personnel should also stay clear of the air compressor when the engine is operating and the air compressor is exposed.

Consult your Perkins distributor for assistance.

i00847451

i01878164

Air Tank Moisture and Sediment - Drain (If Equipped)

Moisture and sediment in the air starting system can cause the following conditions:

- Freezing
- Corrosion of internal parts
- Malfunction of the air starting system

WARNING

When opening the drain valve, wear protective gloves, a protective face shield, protective clothing, and protective shoes. Pressurized air could cause debris to be blown and result in personal injury.

1. Open the drain valve that is on the bottom of the air tank. Allow the moisture and sediment to drain.
2. Close the drain valve.
3. Check the air supply pressure. The air starting motor requires a minimum of 620 kPa (90 psi) of air pressure to operate properly. The maximum air pressure must not exceed 1550 kPa (225 psi). The normal air pressure will be 758 to 965 kPa (110 to 140 psi).

i08232552

Battery - Recycle

Always recycle a battery. Never discard a battery. Return used batteries to one of the following locations:

- A battery supplier
- An authorized battery collection facility
- A recycling facility

Battery - Replace

WARNING

Batteries give off combustible gases which can explode. A spark can cause the combustible gases to ignite. This can result in severe personal injury or death.

Ensure proper ventilation for batteries that are in an enclosure. Follow the proper procedures in order to help prevent electrical arcs and/or sparks near batteries. Do not smoke when batteries are serviced.

WARNING

The battery cables or the batteries should not be removed with the battery cover in place. The battery cover should be removed before any servicing is attempted.

Removing the battery cables or the batteries with the cover in place may cause a battery explosion resulting in personal injury.

1. Switch the engine to the OFF position. Remove all electrical loads.
2. Turn off any battery chargers. Disconnect any battery chargers.
3. The NEGATIVE “-” cable connects the NEGATIVE “-” battery terminal to the NEGATIVE “-” terminal on the starter motor. Disconnect the cable from the NEGATIVE “-” battery terminal.
4. The POSITIVE “+” cable connects the POSITIVE “+” battery terminal to the POSITIVE “+” terminal on the starting motor. Disconnect the cable from the POSITIVE “+” battery terminal.

Note: Always recycle a battery. Never discard a battery. Return used batteries to an appropriate recycling facility.

5. Remove the used battery.
6. Install the new battery.

Note: Before the cables are connected, ensure that the engine start switch is OFF.

7. Connect the cable from the starting motor to the POSITIVE “+” battery terminal.

8. Connect the cable from the NEGATIVE “-” terminal on the starter motor to the NEGATIVE “-” battery terminal.

i06221249

i02747977

Battery Electrolyte Level - Check

When the engine is not run for long periods of time or when the engine is run for short periods, the batteries may not fully recharge. Ensure a full charge in order to help prevent the battery from freezing. If batteries are correctly charged, the ammeter reading should be very near zero, when the engine is in operation.

WARNING

All lead-acid batteries contain sulfuric acid which can burn the skin and clothing. Always wear a face shield and protective clothing when working on or near batteries.

1. Remove the filler caps. Maintain the electrolyte level to the “FULL” mark on the battery.

If the addition of water is necessary, use distilled water. If distilled water is not available use clean water that is low in minerals. Do not use artificially softened water.

2. Check the condition of the electrolyte with a suitable battery tester.
3. Install the caps.
4. Keep the batteries clean.

Clean the battery case with one of the following cleaning solutions:

- Use a solution of 0.1 kg (0.2 lb) baking soda and 1 L (1 qt) of clean water.
- Use a solution of ammonium hydroxide.

Thoroughly rinse the battery case with clean water.

Battery or Battery Cable - Disconnect

WARNING

The battery cables or the batteries should not be removed with the battery cover in place. The battery cover should be removed before any servicing is attempted.

Removing the battery cables or the batteries with the cover in place may cause a battery explosion resulting in personal injury.

1. Turn the start switch to the OFF position. Turn the ignition switch (if equipped) to the OFF position and remove the key and all electrical loads.
2. Disconnect the negative battery terminal. Ensure that the cable cannot contact the terminal. When four 12 V batteries are involved, 2 negative connections must be disconnected.
3. Remove the positive connection.
4. Clean all disconnected connection and battery terminals.
5. Use a fine grade of sandpaper to clean the terminals and the cable clamps. Clean the items until the surfaces are bright or shiny. DO NOT remove material excessively. Excessive removal of material can cause the clamps to fit incorrectly. Coat the clamps and the terminals with a suitable silicone lubricant or petroleum jelly.
6. Tape the cable connections in order to help prevent accidental starting.
7. Proceed with necessary system repairs.
8. In order to connect the battery, connect the positive connection before the negative connector.

i06934547

Belts - Inspect/Adjust/Replace

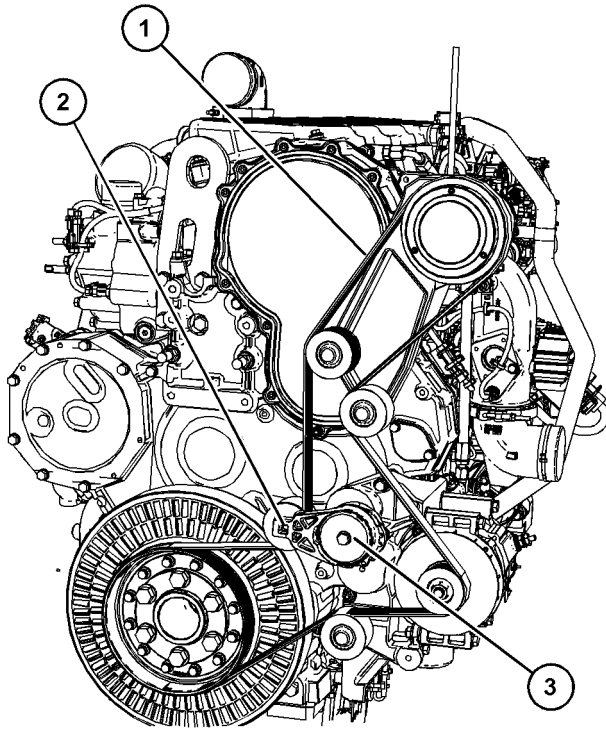

Illustration 32

g06046748

Typical example

- (1) Belt
- (2) Square drive
- (3) Tensioner

Inspect

To maximize the engine performance, inspect the belt for wear and for cracking. Replace the belt if the belt is worn or damaged.

- Inspect the belt for cracks, splits, glazing, grease, displacement of the cord and evidence of fluid contamination.

The belt must be replaced if the following conditions are present.

- The belt has a crack in more than one rib.

- More than one section of the belt is displaced in one rib of a maximum length of 50.8 mm (2 inch)

Adjust

The engine is equipped with an automatic belt tensioner (3). Manual adjustment of the belt is not required.

Replace

The tensioner (3) has a square drive (2) that can be used to remove the tension from the belt, allowing the belt to be removed. For a full description on replacing the belt refer to Disassembly and Assembly, Alternator Belt - Remove and Install.

i06221395

Coolant (DEAC) - Change

Clean the cooling system and flush the cooling system before the recommended maintenance interval if the following conditions exist:

- The engine overheats frequently.
- Foaming is observed.
- The oil has entered the cooling system and the coolant is contaminated.
- The fuel has entered the cooling system and the coolant is contaminated.

Note: Inspect the water pump and the water temperature regulator after the cooling system has been drained.

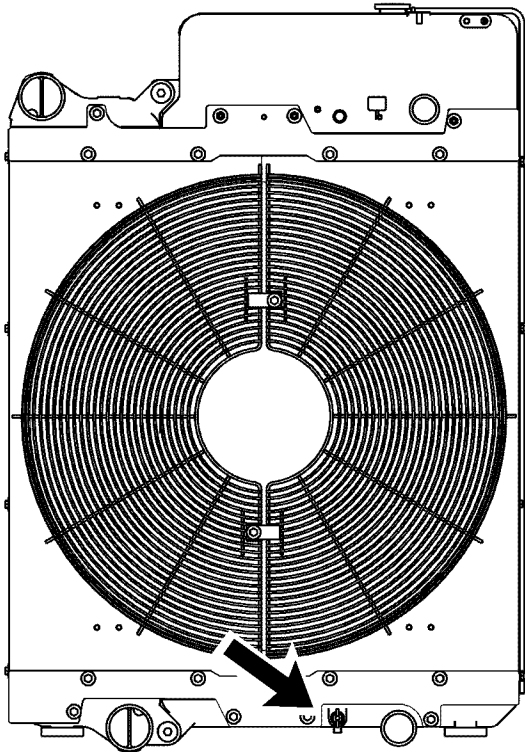

Illustration 33

g02351659

Typical example of a cooling system drain valve. The valve is towards the bottom of the radiator.

Drain

⚠ WARNING

Pressurized System: Hot coolant can cause serious burns. To open the cooling system filler cap, stop the engine and wait until the cooling system components are cool. Loosen the cooling system pressure cap slowly in order to relieve the pressure.

1. Stop the engine and allow the engine to cool.
Loosen the cooling system filler cap slowly in order to relieve any pressure. Remove the cooling system filler cap.
2. Open the cooling system drain valve.
Allow the coolant to drain.

Flush

1. Flush the cooling system with clean water and a suitable cleaning agent in order to remove any debris. Refer to your Perkins distributor for suitable cleaning agents.
2. Close the cooling system drain valve.

NOTICE

Do not fill the cooling system faster than 5 L (1.3 US gal) per minute to avoid air locks.

Cooling system air locks may result in engine damage.

3. Fill the cooling system with clean water and install the cooling system filler cap.
4. Start and run the engine until normal operating temperature.
5. Stop the engine and allow the engine to cool. Loosen the cooling system filler cap slowly in order to relieve any pressure. Remove the cooling system filler cap. Open the cooling system drain valve. Allow the water to drain. Flush the cooling system with clean water.
6. Close the cooling system drain valve.

Fill

NOTICE

Fill the cooling system no faster than 19 L (5 US gal) per minute to avoid air locks.

1. Fill the cooling system with coolant/antifreeze. Refer to this Operation and Maintenance Manual, "Fluid Recommendations" topic for more information on cooling system specifications. Do not install the cooling system filler cap.
2. Start and run the engine at low idle. Increase the engine rpm to 1500 rpm. Run the engine at high idle for 1 minute in order to purge the air from the cavities of the engine block. Stop the engine.
3. Check the coolant level. Maintain the coolant level within 13 mm (0.5 inch) below the bottom of the pipe for filling. Maintain the coolant level within 13 mm (0.5 inch) to the proper level on the sight glass.
4. Clean the cooling system filler cap. Inspect the gasket that is on the cooling system filler cap. If the gasket that is on the cooling system filler cap is damaged, discard the old filler cap and install a new filler cap. If the gasket that is on the cooling system filler cap is not damaged, perform a pressure test. The correct pressure for the cooling system filler cap is stamped on the face of the cooling system filler cap. If the cooling system filler cap does not retain the correct pressure, install a new cooling system filler cap.

5. Start the engine. Inspect the cooling system for leaks and for proper operating temperature.

i06221440

Coolant (ELC) - Change

NOTICE

Perkins ELC must be using with an extender in order to achieve 12000 hours operation. For more information on a suitable extender contact your Perkins distributor.

Clean the cooling system and flush the cooling system before the recommended maintenance interval if the following conditions exist:

- The engine overheats frequently.
- Foaming is observed.
- The oil has entered the cooling system and the coolant is contaminated.
- The fuel has entered the cooling system and the coolant is contaminated.

Note: When the cooling system is cleaned, only clean water is needed when the ELC is drained and replaced.

Note: Inspect the water pump and the water temperature regulator after the cooling system has been drained.

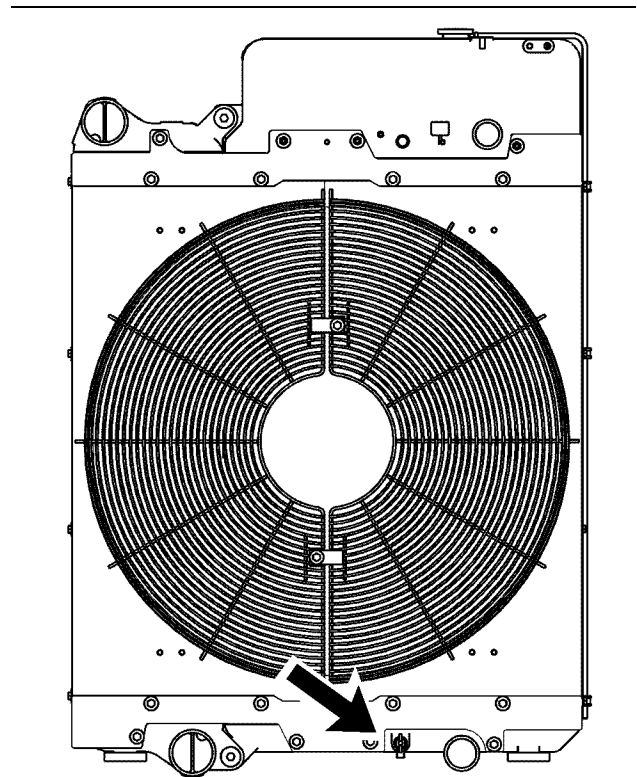

Illustration 34

g02351659

Typical example

Drain

WARNING

Pressurized System: Hot coolant can cause serious burns. To open the cooling system filler cap, stop the engine and wait until the cooling system components are cool. Loosen the cooling system pressure cap slowly in order to relieve the pressure.

1. Stop the engine and allow the engine to cool.
Loosen the cooling system filler cap slowly in order to relieve any pressure. Remove the cooling system filler cap.
2. Open the cooling system drain valve.
Allow the coolant to drain.

Flush

1. Flush the cooling system with clean water in order to remove any debris.
2. Close the drain valve.

NOTICE

Fill the cooling system no faster than 19 L (5 US gal) per minute to avoid air locks.

3. Fill the cooling system with clean water. Install the cooling system filler cap.
4. Start and run the engine at low idle until the temperature reaches 49 to 66 °C (120 to 150 °F).
5. Stop the engine and allow the engine to cool. Loosen the cooling system filler cap slowly in order to relieve any pressure. Remove the cooling system filler cap. Open the drain valve. Allow the water to drain. Flush the cooling system with clean water. Close the drain valve.

Fill**NOTICE**

Fill the cooling system no faster than 19 L (5 US gal) per minute to avoid air locks.

1. Fill the cooling system with Extended Life Coolant (ELC). Refer to this Operation and Maintenance Manual, "Fluid Recommendations" for more information on cooling system specifications. Do not install the cooling system filler cap.
2. Start and run the engine at low idle. Increase the engine rpm to high idle. Run the engine at high idle for 1 minute in order to purge the air from the cavities of the engine block. Stop the engine.
3. Check the coolant level. Maintain the coolant level within 13 mm (0.5 inch) below the bottom of the pipe for filling. Maintain the coolant level within 13 mm (0.5 inch) to the proper level on the sight glass.
4. Clean the cooling system filler cap. Inspect the gasket that is on the cooling system filler cap. Only install the used filler cap if the gasket is not damaged. Test the cap for the correct pressure. The correct pressure for the cooling system filler cap is stamped on the face of the cooling system filler cap. If the cooling system filler cap does not retain the correct pressure, install a new cooling system filler cap.

5. Start the engine. Inspect the cooling system for leaks and for the correct operating temperature.

i05197396

Coolant Extender (ELC) - Add

In order for Perkins ELC to achieve 12000 hours an extender must be added at 6000 hours. For a suitable extender, contact your Perkins dealer or Perkins distributor.

i03842450

Coolant Level - Check

Check the coolant level when the engine is stopped and cool.

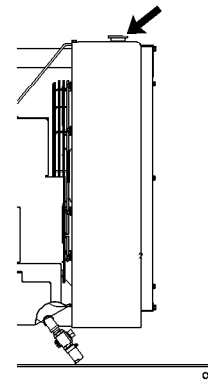

Illustration 35

g00285520

Cooling system filler cap

WARNING

Pressurized System: Hot coolant can cause serious burns. To open the cooling system filler cap, stop the engine and wait until the cooling system components are cool. Loosen the cooling system pressure cap slowly in order to relieve the pressure.

1. Remove the cooling system filler cap slowly in order to relieve pressure.
2. Maintain the coolant level within 13 mm (0.5 inch) of the bottom of the filler pipe. If the engine is equipped with a sight glass, maintain the coolant level to the proper level in the sight glass.

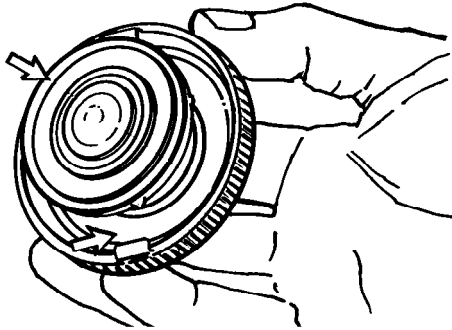

Illustration 36

g00103639

Typical filler cap gaskets

3. Clean the cooling system filler cap and check the condition of the filler cap gaskets. Replace the cooling system filler cap if the filler cap gaskets are damaged. Reinstall the cooling system filler cap.
4. Inspect the cooling system for leaks.

i06223869

Coolant Temperature Regulator - Replace

Replace the water temperature regulator before the water temperature regulator fails. Replacing the water temperature regulator reduces the chances for unscheduled downtime.

A water temperature regulator that fails in a partially opened position can cause overheating or overcooling of the engine.

A water temperature regulator that fails in the open position will cause the engine operating temperature to be too low during partial load operation. Low engine operating temperatures during partial loads could cause an excessive carbon buildup inside the cylinders. This excessive carbon buildup could result in an accelerated wear of the piston rings and wear of the cylinder liner.

A water temperature regulator that fails in the closed position can cause excessive overheating. Excessive overheating could result in cracking of the cylinder head or piston seizure problems.

NOTICE

Failure to replace the water temperature regulator on a regularly scheduled basis could cause severe engine damage.

Perkins engines incorporate a shunt design cooling system and require operating the engine with a water temperature regulator installed.

If the water temperature regulator is installed incorrectly, the engine may overheat, causing cylinder head damage. Ensure that the new water temperature regulator is installed in the original position. Ensure that the water temperature regulator vent hole is open.

Do not use liquid gasket material on the gasket or cylinder head surface.

NOTICE

Care must be taken to ensure that fluids are contained during performance of inspection, maintenance, testing, adjusting, and repair of the product. Be prepared to collect the fluid with suitable containers before opening any compartment or disassembling any component containing fluids.

Dispose of all fluids according to local regulations and mandates.

Note: If replacing only the water temperature regulator, only drain the coolant to a level that is below the water temperature regulator housing.

Refer to Disassembly and Assembly, "Water Temperature Regulator - Remove and Install" for the replacement procedure.

i03644948

Cooling System Supplemental Coolant Additive (SCA) - Test/Add

WARNING

Cooling system coolant additive contains alkali. To help prevent personal injury, avoid contact with the skin and the eyes. Do not drink cooling system coolant additive.

Test for SCA Concentration

Heavy-Duty Coolant/Antifreeze and SCA

NOTICE

Do not exceed the recommended six percent supplemental coolant additive concentration.

Use a Coolant Conditioner Test Kit in order to check the concentration of the SCA.

Add the SCA, If Necessary

NOTICE

Do not exceed the recommended amount of supplemental coolant additive concentration. Excessive supplemental coolant additive concentration can form deposits on the higher temperature surfaces of the cooling system, reducing the engine's heat transfer characteristics. Reduced heat transfer could cause cracking of the cylinder head and other high temperature components. Excessive supplemental coolant additive concentration could also result in radiator tube blockage, overheating, and/or accelerated water pump seal wear. Never use both liquid supplemental coolant additive and the spin-on element (if equipped) at the same time. The use of those additives together could result in supplemental coolant additive concentration exceeding the recommended maximum.

WARNING

Pressurized System: Hot coolant can cause serious burns. To open the cooling system filler cap, stop the engine and wait until the cooling system components are cool. Loosen the cooling system pressure cap slowly in order to relieve the pressure.

NOTICE

When any servicing or repair of the engine cooling system is performed the procedure must be performed with the engine on level ground. This will allow you to accurately check the coolant level. This will also help in avoiding the risk of introducing an air lock into the coolant system.

1. Slowly loosen the cooling system filler cap in order to relieve the pressure. Remove the cooling system filler cap.

Note: Always discard drained fluids according to local regulations.

2. If necessary, drain some coolant from the cooling system into a suitable container in order to allow space for the extra SCA.

3. Add the correct amount of SCA. Refer to the Operation and Maintenance Manual, "Refill Capacities and Recommendations" for more information on SCA requirements.
4. Clean the cooling system filler cap and inspect the gasket. If the gasket is damaged, discard the old filler cap and install a new filler cap. If the gasket is not damaged, use a suitable pressurizing pump in order to pressure test the filler cap. The correct pressure is stamped on the face of the filler cap. If the filler cap does not retain the correct pressure, install a new filler cap.

i02151646

Driven Equipment - Check

Refer to the OEM specifications for more information on the following maintenance recommendations for the driven equipment:

- Inspection
- Adjustment
- Lubrication
- Other maintenance recommendations

Perform any maintenance for the driven equipment which is recommended by the OEM.

i06225020

Electronic Unit Injector - Check/Replace

WARNING

Be sure the engine cannot be started while this maintenance is being performed. To prevent possible injury, do not use the starting motor to turn the flywheel.

Hot engine components can cause burns. Allow additional time for the engine to cool before measuring/adjusting the unit injectors.

The electronic unit injectors use high voltage. Disconnect the unit injector enable circuit connector in order to prevent personal injury. Do not come in contact with the injector terminals while the engine is running.

The operation of a Perkins engine with an electronic unit injector which is improperly adjusted may reduce engine efficiency. This reduced efficiency may result in excessive fuel usage and/or shortened engine component life.

Note: Only qualified service personnel should perform this maintenance.

Refer to the Systems Operation, Testing and Adjusting, "Electronic Unit Injector - Test" for the test procedure. Refer to Systems Operation, Testing and Adjusting, "Electronic Unit Injector - Adjust" for the adjustment procedure.

Refer to Disassembly and Assembly, "Electronic Unit Injector - Remove" and Disassembly and Assembly, "Electronic Unit Injector - Remove" for the removal and installation of an injector.

NOTICE

The camshafts must be correctly timed with the crankshaft before an adjustment of the lash for the fuel injector is made. The timing pins must be removed from the camshafts before the crankshaft is turned or damage to the cylinder block will be the result.

i06733463

Engine - Clean

 **WARNING**

Personal injury or death can result from high voltage.

Moisture can create paths of electrical conductivity.

Make sure that the electrical system is OFF. Lock out the starting controls and tag the controls "DO NOT OPERATE" .

NOTICE

Accumulated grease and oil on an engine is a fire hazard. Keep the engine clean. Remove debris and fluid spills whenever a significant quantity accumulates on the engine.

Periodic cleaning of the engine is recommended. Steam cleaning the engine will remove accumulated oil and grease. A clean engine provides the following benefits:

- Easy detection of fluid leaks
- Maximum heat transfer characteristics
- Ease of maintenance

Note: Caution must be used to prevent electrical components from being damaged by excessive water when the engine is cleaned. Pressure washers and steam cleaners should not be directed at any electrical connectors, or the junction of cables into the rear of the connectors. Avoid electrical components such as the alternator, the starter, and the ECM. Protect the fuel injection pump from fluids to wash the engine.

Ensure that care is taken that the safety labels, emission label, and all other information labels are not removed during engine cleaning.

i05207494

Engine Air Cleaner Element (Dual Element) - Inspect/Clean/Replace

NOTICE

Never run the engine without an air cleaner element installed. Never run the engine with a damaged air cleaner element. Do not use air cleaner elements with damaged pleats, gaskets or seals. Dirt entering the engine causes premature wear and damage to engine components. Air cleaner elements help to prevent airborne debris from entering the air inlet.

NOTICE

Never service the air cleaner element with the engine running since this will allow dirt to enter the engine.

Servicing the Air Cleaner Elements

Note: The air filter system may not have been provided by Perkins. The procedure that follows is for a typical air filter system. Refer to the OEM information for the correct procedure.

If the air cleaner element becomes plugged, the air can split the material of the air cleaner element. Unfiltered air will drastically accelerate internal engine wear. Refer to the OEM information for the correct air cleaner elements for your application.

- Check the precleaner (if equipped) and the dust bowl daily for accumulation of dirt and debris. Remove any dirt and debris, as needed.
- Operating in dirty conditions may require more frequent service of the air cleaner element.
- The air cleaner element should be replaced at least one time per year. This replacement should be performed regardless of the number of cleanings.

Replace the dirty air cleaner elements with clean air cleaner elements. Before installation, the air cleaner elements should be thoroughly checked for tears and/or holes in the filter material. Inspect the gasket or the seal of the air cleaner element for damage. Maintain a supply of suitable air cleaner elements for replacement purposes.

Dual Element Air Cleaners

The dual element air cleaner contains a primary air cleaner element and a secondary air cleaner element.

The primary air cleaner element can be used up to six times if the element is properly cleaned and properly inspected. The primary air cleaner element should be replaced at least one time per year. This replacement should be performed regardless of the number of cleanings.

The secondary air cleaner element is not serviceable. Refer to the OEM information for instructions in order to replace the secondary air cleaner element.

When the engine is operating in environments that are dusty or dirty, air cleaner elements may require more frequent replacement.

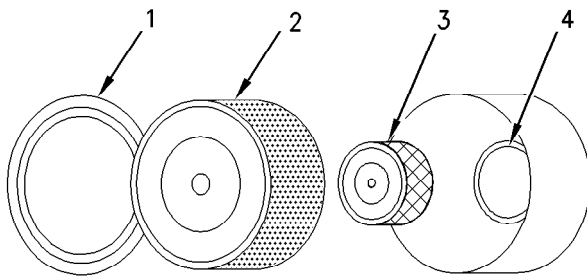

Illustration 37

g00736431

- (1) Cover
- (2) Primary air cleaner element
- (3) Secondary air cleaner element
- (4) Air inlet

1. Remove the cover. Remove the primary air cleaner element.
2. The secondary air cleaner element should be removed and discarded for every three cleanings of the primary air cleaner element.

Note: Refer to “Cleaning the Primary Air Cleaner Elements”.

3. Cover the air inlet with tape in order to keep out dirt.
4. Clean the inside of the air cleaner cover and body with a clean, dry cloth.

5. Remove the tape from the air inlet. Install the secondary air cleaner element. Install a primary air cleaner element that is new or cleaned.
6. Install the air cleaner cover.
7. Reset the air cleaner service indicator.

Cleaning the Primary Air Cleaner Elements

Refer to the OEM information in order to determine the number of times that the primary filter element can be cleaned. When the primary air cleaner element is cleaned, check for rips or tears in the filter material. The primary air cleaner element should be replaced at least one time per year. This replacement should be performed regardless of the number of cleanings.

NOTICE

Do not tap or strike the air cleaner element.

Do not wash the primary air cleaner element.

Use low pressure (207 kPa 30 psi maximum) pressurized air or vacuum cleaning to clean the primary air cleaner element.

Take extreme care in order to avoid damage to the air cleaner elements.

Do not use air cleaner elements that have damaged pleats, gaskets, or seals.

Refer to the OEM information in order to determine the number of times that the primary air cleaner element can be cleaned. Do not clean the primary air filter element more than three times. The primary air cleaner element must be replaced at least one time per year.

Cleaning the air filter element will not extend the life of the air filter element.

Visually inspect the primary air cleaner element before cleaning. Inspect air cleaner elements for damage to the pleats, the seals, the gaskets, and the outer cover. Discard any damaged air cleaner element.

Two methods may be used in order to clean the primary air cleaner element:

- pressurized air
- Vacuum cleaning

Pressurized Air

WARNING

Personal injury can result from air pressure.

Personal injury can result without following proper procedure. When using pressure air, wear a protective face shield and protective clothing.

Maximum air pressure at the nozzle must be less than 205 kPa (30 psi) for cleaning purposes.

Pressurized air can be used to clean primary air cleaner elements that have not been cleaned more than three times. Use filtered, dry air with a maximum pressure of 207 kPa (30 psi). Pressurized air will not remove deposits of carbon and oil.

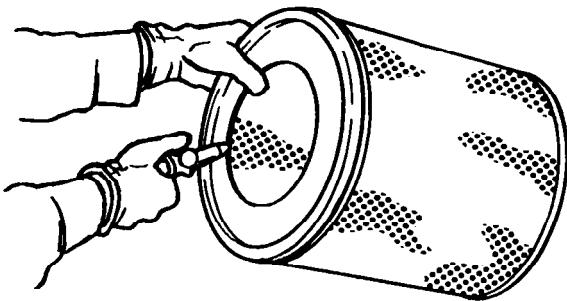

Illustration 38

g00281692

Note: When the primary air cleaner elements are cleaned, always begin with the clean side (inside) in order to force dirt particles toward the dirty side (outside).

Aim the air hose so that air flows along the length of the filter. Follow the direction of the paper pleats in order to prevent damage to the pleats. Do not aim the air directly at the face of the paper pleats.

Note: Refer to “Inspecting the Primary Air Cleaner Elements”.

Vacuum Cleaning

Vacuum cleaning is a good method for removing accumulated dirt from the dirty side (outside) of a primary air cleaner element. Vacuum cleaning is especially useful for cleaning primary air cleaner elements which require daily cleaning because of a dry, dusty environment.

Cleaning from the clean side (inside) with pressurized air is recommended prior to vacuum cleaning the dirty side (outside) of a primary air cleaner element.

Note: Refer to “Inspecting the Primary Air Cleaner Elements”.

Inspecting the Primary Air Cleaner Elements

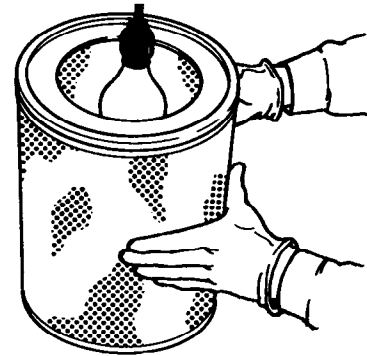

Illustration 39

g00281693

Inspect the clean, dry primary air cleaner element. Use a 60 W blue light in a dark room or in a similar facility. Place the blue light in the primary air cleaner element. Rotate the primary air cleaner element. Inspect the primary air cleaner element for tears and/or holes. Inspect the primary air cleaner element for light that may show through the filter material. If it is necessary in order to confirm the result, compare the primary air cleaner element to a new primary air cleaner element that has the same part number.

Do not use a primary air cleaner element that has any tears and/or holes in the filter material. Do not use a primary air cleaner element with damaged pleats, gaskets, or seals. Discard damaged primary air cleaner elements.

i04150572

Engine Air Cleaner Element (Single Element) - Inspect/Clean/Replace

Perform the Operation and Maintenance Manual, “Engine Air Cleaner Service Indicator-Inspect” procedure and perform the Operation and Maintenance Manual, “Engine Air Precleaner Check/Clean” procedure (if equipped) before performing the following procedure.

i06221262

NOTICE

Never run the engine without an air cleaner element installed. Never run the engine with a damaged air cleaner element. Do not use air cleaner elements with damaged pleats, gaskets or seals. Dirt entering the engine causes premature wear and damage to engine components. Air cleaner elements help to prevent airborne debris from entering the air inlet.

NOTICE

Never service the air cleaner element with the engine running since this will allow dirt to enter the engine.

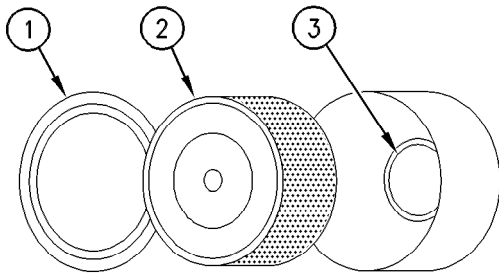

Illustration 40

g00310664

- (1) Air cleaner cover
(2) Air filter element
(3) Air inlet

1. Remove air cleaner cover (1) and remove air filter element (2).
2. Cover air inlet (3) with tape or a clean cloth so that debris cannot enter the air inlet.
3. Clean the inside of air cleaner cover (1). Clean the body that holds the air cleaner element.
4. Inspect the replacement element for the following items: damage, dirt and debris.
5. Remove the seal from the opening of the air inlet.
6. Install a clean, undamaged air filter element (2).
7. Install air cleaner cover (1).
8. Reset the air cleaner service indicator.

Engine Air Cleaner Service Indicator - Inspect (If Equipped)

Some engines may be equipped with a different service indicator.

Some engines are equipped with a differential gauge for inlet air pressure. The differential gauge for inlet air pressure displays the difference in the pressure that is measured before and after the air cleaner element. As the air cleaner element becomes dirty, the pressure differential rises. If your engine is equipped with a different type of service indicator, follow the OEM recommendations in order to service the air cleaner service indicator.

The service indicator may be mounted on the clean side of the air cleaner housing or in a remote location.

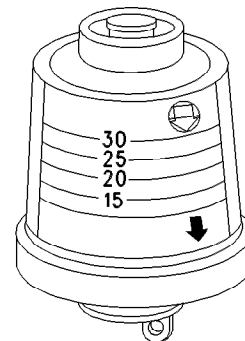

Illustration 41

g00103777

Typical service indicator

Observe the service indicator. The air cleaner element should be cleaned or the air cleaner element should be replaced when one of the following conditions occur:

- The yellow diaphragm enters the red zone.
- The red piston locks in the visible position.

Test the Service Indicator

Service indicators are important instruments.

- Check for ease of resetting. The service indicator should reset in less than three pushes.
- Check the movement of the service indicator core when the engine is run at full load speed. The core should latch approximately at the greatest vacuum that is attained.

If the service indicator does not reset easily, or if the core does not latch at the greatest vacuum, the service indicator should be replaced. If the new service indicator will not reset, the hole for the service indicator may be plugged.

If necessary, replace the service indicator more frequently in environments that are severely dusty. Replace the service indicator annually regardless of the operating conditions. Replace the service indicator when the engine is overhauled, and whenever major engine components are replaced.

Note: When a new service indicator is installed, excessive force may crack the top of the service indicator. Tighten the service indicator to a torque of 2 N·m (18 lb in).

i07819538

Engine Mounts - Inspect

Note: The engine mounts may not have been supplied by Perkins. Refer to the Original Equipment Manufacturer (OEM) information for further details on the engine mounts and the correct bolt torque.

Inspect the engine mounts for deterioration and for correct bolt torque. Excessive engine vibration can be caused by the following conditions:

- Incorrect mounting of the engine
- Deterioration of the engine mounts
- Loose engine mounts

Any engine mount that shows deterioration should be replaced. Refer to the OEM information for the recommended torques.

When the engine mounts are supplied by Perkins the maintenance procedure will be supplied in the Disassembly and Assembly manual for your engine.

i06934495

Engine Oil Level - Check

WARNING

Hot oil and hot components can cause personal injury. Do not allow hot oil or hot components to contact the skin.

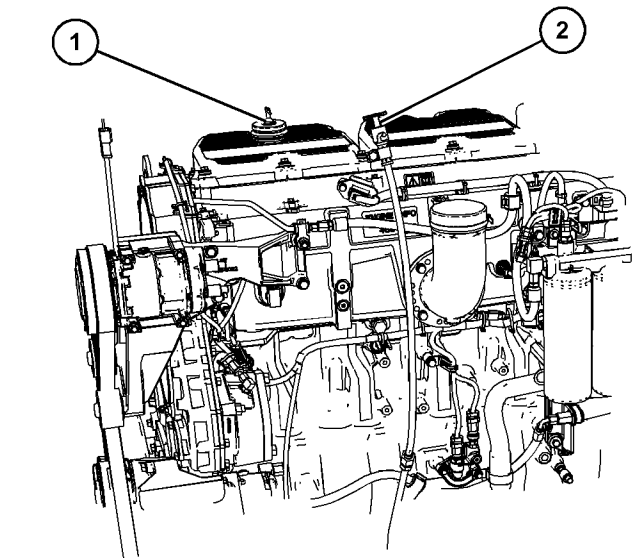

Illustration 42

g06174074

Typical installation of the oil level gauge

- (1) Oil filler cap
(2) Oil level gauge

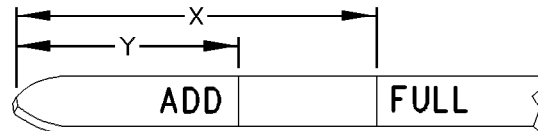

Illustration 43

g00110310

Partial view of the oil level gauge

- (Y) "ADD" mark
(X) "FULL" mark

NOTICE

Perform this maintenance with the engine stopped.

NOTICE

Engine damage can occur if the crankcase is filled above the "FULL" mark on the oil level gauge (dipstick).

An overfull crankcase can cause the crankshaft to dip into the oil. This will reduce the power that is developed and also force air bubbles into the oil. These bubbles (foam) can cause the following problems: reduction of the oil's ability to lubricate, reduction of oil pressure, inadequate cooling, oil blowing out of the crankcase breathers and excessive oil consumption.

Excessive oil consumption will cause deposits to form on the pistons and in the combustion chamber. Deposits in the combustion chamber lead to the following problems: guttering of the valves, packing of carbon under the piston rings and wear of the cylinder liner.

If the oil level is above the "FULL" mark on the oil level gauge, drain some of the oil immediately.

1. Remove the oil filler cap and check the oil level. Maintain the oil level between the "ADD" mark (Y) and the "FULL" mark (X) on the oil level gauge (1). Do not fill the crankcase above "FULL" mark (X).
2. To choose the correct type of oil for this engine, refer to this Operation and Maintenance Manual, "Fluid Recommendations".
3. Clean the oil filler cap. Install the oil filler cap.
4. Record the amount of oil that is added. For the next oil sample and analysis, include the total amount of oil that has been added since the previous sample. Recording this information helps to provide the most accurate oil analysis.

i01907674

Engine Oil Sample - Obtain

The condition of the engine lubricating oil may be checked at regular intervals as part of a preventive maintenance program. Perkins include an oil sampling valve as an option. The oil sampling valve (if equipped) is included in order to regularly sample the engine lubricating oil. The oil sampling valve is positioned on the oil filter head or the oil sampling valve is positioned on the cylinder block.

Perkins recommends using a sampling valve in order to obtain oil samples. The quality and the consistency of the samples are better when a sampling valve is used. The location of the sampling valve allows oil that is flowing under pressure to be obtained during normal engine operation.

Obtain the Sample and the Analysis

WARNING

Hot oil and hot components can cause personal injury. Do not allow hot oil or hot components to contact the skin.

In order to help obtain the most accurate analysis, record the following information before an oil sample is taken:

- The date of the sample
- Engine model
- Engine number
- Service hours on the engine
- The number of hours that have accumulated since the last oil change
- The amount of oil that has been added since the last oil change

Ensure that the container for the sample is clean and dry. Also ensure that the container for the sample is clearly labelled.

To ensure that the sample is representative of the oil in the crankcase, obtain a warm, well mixed oil sample.

To avoid contamination of the oil samples, the tools and the supplies that are used for obtaining oil samples must be clean.

The sample can be checked for the following: the quality of the oil, the existence of any coolant in the oil, the existence of any ferrous metal particles in the oil and the existence of any nonferrous metal particles in the oil.

i07124142

Engine Oil and Filter - Change

WARNING

Hot oil and hot components can cause personal injury. Do not allow hot oil or hot components to contact the skin.

NOTICE

Care must be taken to ensure that fluids are contained during performance of inspection, maintenance, testing, adjusting and repair of the product. Be prepared to collect the fluid with suitable containers before opening any compartment or disassembling any component containing fluids.

Dispose of all fluids according to local regulations and mandates.

NOTICE

Keep all parts clean from contaminants.

Contaminants may cause rapid wear and shortened component life.

Oil and Filter Change Intervals

The standard engine oil and filter change period is 500 hours. There are several other factors that can alter the standard engine oil and filter change of 500 hours.

- If the engine is using engine oil analysis to determine oil and filter change period.
- The engine is working in a severe service environment/Load Factor
- Infrequent operation of the engine

Refer to this Operation and Maintenance Manual, Severe Service Application for more information on reducing the engine oil and filter change period. For severe service applications the recommended oil and filter change period is 250 hours.

If the engine is operated in severe service conditions, Perkins recommends the use of engine oil sampling. Refer to this Operation and Maintenance Manual, Engine Oil sample - Obtain for more information.

If the engine is operated infrequently less than 500 hours in a 12-month period, then the engine oil and filter change should be conducted yearly.

Drain the Engine Lubricating Oil

Do not drain the engine lubricating oil when the engine is cold. As the engine lubricating oil cools, suspended waste particles settle on the bottom of the oil pan. The waste particles are not removed with draining cold oil. Drain the oil pan with the engine stopped. Drain the oil pan with the oil warm. This draining method allows the waste particles that are suspended in the oil to be drained properly.

Failure to follow this recommended procedure will cause the waste particles to be recirculated through the engine lubrication system with the new oil.

Note: Ensure that the vessel that will be used is large enough to collect the waste oil.

After the engine has been run at the normal operating temperature, stop the engine. Use one of the following methods to drain the engine oil pan:

- If the engine is equipped with a drain valve, turn the drain valve knob counterclockwise to drain the oil. After the oil has drained, turn the drain valve knob clockwise to close the drain valve.
- If the engine is not equipped with a drain valve, remove the oil drain plug to allow the oil to drain.

After the oil has drained, the oil drain plug should be cleaned. If necessary, replace the O ring seal and install the plug. Tighten the drain plug to 35 N·m (26 lb ft).

Replace the Oil Filter

Note: Engine oil filter can be on engine or connected remotely. The engine oil filter in this section is the remote type of instillation. The basic removing and installing procedures can be applied to both types of oil filter installation

NOTICE

Perkins oil filters are manufactured to Perkins specifications. Use of an oil filter that is not recommended by Perkins could result in severe damage to the engine bearings, and crankshaft. As a result of the larger waste particles from unfiltered oil entering the engine lubricating system. Only use oil filters recommended by Perkins.

1. Ensure that the oil filter and the area around the oil filter is clean before removal. Remove the oil filter with a suitable tool.

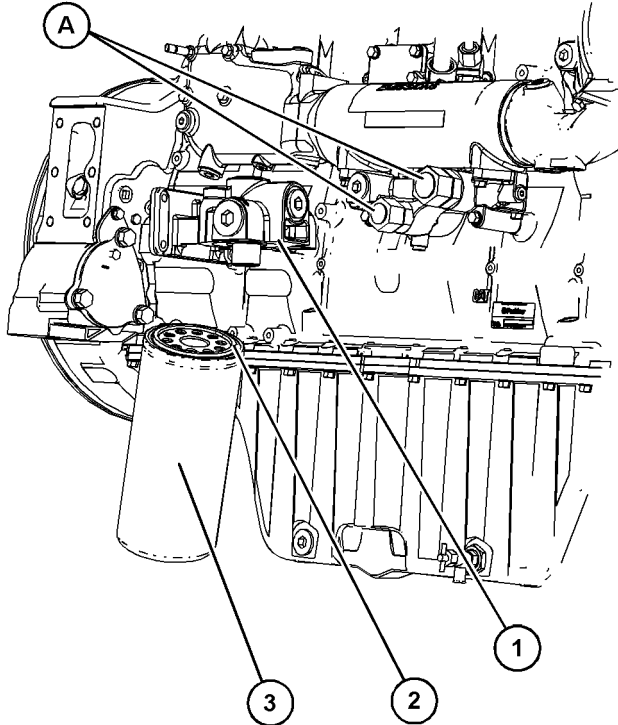

Illustration 44

g06174433

(A) Connections for the remote oil filter

2. Clean sealing surface (1).
3. Apply clean engine oil to O ring seal (2) for the new oil filter (3).

NOTICE

Do not fill the oil filter with oil before installing. This oil would not be filtered and could be contaminated. Contaminated oil can cause accelerated wear to engine components.

4. Install the new oil filter (3). Spin on the oil filter until the O ring (2) contacts the sealing surface (1). Then rotate the oil filter 1 full turn. Remove the container and disposal of the waste oil in accordance with local regulations.

Fill the Oil Pan

1. Remove the oil filler cap. Refer to this Operation and Maintenance Manual, "Fluid Recommendations" for more information on suitable oils. Fill the oil pan with the correct amount of new engine lubricating oil. Refer to this Operation and Maintenance Manual, "Refill Capacities" for more information on refill capacities.

2. Start the engine and run the engine at LOW IDLE for 2 minutes. Perform this procedure to ensure that the lubrication system has oil and that the oil filters are filled. Inspect the oil filter for oil leaks.
3. Stop the engine and allow the oil to drain back to the oil pan for a minimum of 10 minutes.
4. Remove the oil level gauge to check the oil level. Maintain the oil level between the ADD and FULL marks on the side of the oil level gauge.

i07512811

Engine Valve Lash - Check**WARNING**

Ensure that the engine cannot be started while this maintenance is being performed. To help prevent possible injury, do not use the starting motor to turn the flywheel.

Hot engine components can cause burns. Allow additional time for the engine to cool before measuring/adjusting valve lash clearance.

NOTICE

Only qualified service personnel should perform this maintenance. Refer to the Service Manual or your authorized Perkins dealer or your Perkins distributor for the complete valve lash adjustment procedure.

Operation of Perkins engines with incorrect valve lash can reduce engine efficiency, and also reduce engine component life.

The initial valve lash adjustment on new engines, rebuilt engines, or remanufactured engines is recommended only on engine ratings 522 kW (700 hp) and greater. The adjustment is necessary due to the initial wear of the valve train components and to the seating of the valve train components.

This maintenance is recommended as part of a lubrication and preventive maintenance schedule to help provide maximum engine life. For engine ratings less than 522 kW (700 hp), the initial valve lash adjustment is not necessary.

Note: All engine ratings must have the engine valve lash performed at 2500 hours.

Ensure that the engine is stopped before measuring the valve lash. To obtain an accurate measurement, allow the valves to cool before this maintenance is performed.

During valve adjustment, visibly inspect the valve train of wear or damage.

Refer to Systems Operation, Testing and Adjusting, "Engine Valve Lash - Inspect/Adjust" for more information.

i06933198

i06891886

Engine Valve Rotators - Inspect

NOTICE

A valve rotator which does not operate properly will accelerate valve face wear and valve seat wear and shorten valve life. If a damaged rotator is not replaced, valve face guttering could result and cause pieces of the valve to fall into the cylinder. This can cause piston and cylinder head damage.

Note: Use of a platform may be necessary to reach the engine valve rotators.

Perform this procedure after the valve lash has been set.

Note: Ensure that the engine cannot be started except by the person performing the maintenance procedure. Install a "DO NOT OPERATE" tag near the starting mechanism.

1. Remove the covers for the valve mechanisms. Refer to the Disassembly and Assembly Manual, "Valve Cover - Remove and Install" for the procedure.
2. Mark the tops of the valve rotators with a permanent marker. Note the position of the marks.
3. Install the covers for the valve mechanisms. Refer to the Disassembly and Assembly Manual, "Valve Cover - Remove and Install" for the procedure.
4. Start the engine. Operate the engine for 5 minutes. Stop the engine.
5. Remove the covers for the valve mechanisms. Refer to the Disassembly and Assembly Manual, "Valve Cover - Remove and Install" for the procedure.
6. Observe the position of the marks that are on the valve rotators.
7. If any valve fails to rotate, consult your Perkins distributor.
8. Install the covers for the valve mechanisms. Refer to the Disassembly and Assembly Manual, "Valve Cover - Remove and Install" for the procedure.

Fuel System - Prime (General Instructions)

WARNING

Fuel leaked or spilled onto hot surfaces or electrical components can cause a fire. To help prevent possible injury, turn the start switch off when changing fuel filters or water separator elements. Clean up fuel spills immediately.

Refer to this Operation and Maintenance Manual, "General Hazard Information" before any adjustments or repairs are performed

If necessary, perform minor adjustments. Repair any leaks from the fuel system and from the cooling, lubrication, or air systems. Ensure that all adjustments and repairs are performed by authorized personnel that have had the correct training.

The fuel system should be primed under the following conditions:

- The fuel tank is empty or the fuel tank has been partially drained.
- The engine has been in storage.
- The fuel filter has been replaced.
- The pressure fuel lines have been disconnected.

Priming Fuel Pumps

Two different types of fuel priming pumps are available. The mechanical hand prime design and the electrically operated design.

Mechanical Operated Hand Priming Pump

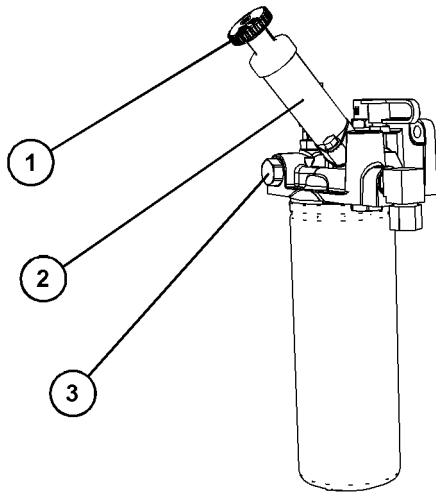

Illustration 45

g06173517

Typical example

- (1) Pump handle
- (2) Body of priming pump
- (3) Vent Plug

1. Ensure that the key switch is in the OFF position. Ensure that the fuel tank is full of clean diesel fuel. Check that the fuel supply valve (if equipped) is in the "ON" position
2. Unlock the fuel priming pump handle (1). Turn handle counter-clockwise. If equipped, loosen vent plug (3) and operate priming pump handle (1) until fuel free of air comes from vent plug (3). Tighten vent plug (3) to a torque of 35 N·m (309 lb in).
3. Operate the fuel priming pump handle until strong pressure is felt.

Note: The location of the fuel tank and the amount of fuel in the fuel tank can affect the time taken to prime the fuel system.

4. When strong pressure can be felt, press in the fuel priming pump handle (1) and lock the handle into the fuel pump body (2). To lock the handle, turn handle clockwise.

Note: The stronger the pressure in the fuel system the quicker the engine will start.

NOTICE

Do not crank the engine continuously for more than 30 seconds. Allow the starting motor to cool for two minutes before cranking the engine again.

5. Start the engine, refer to this Operation and Maintenance Manual, "Starting the Engine" for more information.
6. If the engine will not start, repeat Step 2 to Step 4.
7. Once the engine starts, allow the engine to operate with no load for 5 minutes.
8. If the engine will not start, refer to Troubleshooting, "Engine Cranks but will not Start".

Electrically Operated Priming Pump

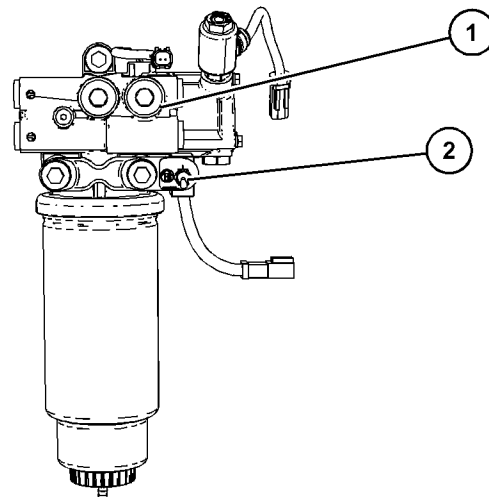

Illustration 46

g06046130

Typical example

- (1) Electric fuel priming pump
- (2) Fuel priming pump switch

1. Ensure that the engine power supply is in the ON position. The fuel system can be primed from the keyswitch or from a remote mounted switch (2).
2. Using the fuel priming switch (2) to prime the fuel system. Turn the fuel priming switch (2) to the ON position. Hold the fuel priming switch in the ON position for 2 minutes.
3. Verify that the water separator is full of fuel.

Maintenance Section
Fuel System Primary Filter (Water Separator) Element - Replace

- If the water separator is not full of fuel, turn the fuel priming switch (2) OFF and then turn the fuel priming switch (2) ON. This action will cycle the fuel priming pump again.

Note: The location of the fuel tank and the amount of fuel in the fuel tank can affect the time taken to prime the fuel system.

- When the water separator is full of fuel, attempt to start the engine. If the engine starts and the engine runs rough or the engine misfires, operate at low idle until the engine is running smoothly. If the engine cannot be started, or if the engine continues to misfire or smoke, repeat Step 2.
- The fuel system can also be primed by using the key switch. Turn the key to the ON position for 2 minutes. After 2 minutes the fuel system should be primed. If necessary, by cycling the key switch the system will prime again for 2 minutes.
- If the engine will not start, refer to Troubleshooting, "Engine Cranks but will not Start".

Original Equipment Manufacture

Original Equipment Manufacture (OEM) may have installed fuel priming system. Refer to OEM for priming instructions.

i06936211

Fuel System Primary Filter (Water Separator) Element - Replace

WARNING

Fuel leaked or spilled onto hot surfaces or electrical components can cause a fire. To help prevent possible injury, turn the start switch off when changing fuel filters or water separator elements. Clean up fuel spills immediately.

NOTICE

Do not allow dirt to enter the fuel system. Thoroughly clean the area around a fuel system component that will be disconnected. Fit a suitable cover over any disconnected fuel system components.

NOTICE

Do not fill fuel filters with fuel before installing them. The fuel will not be filtered and could be contaminated. Contaminated fuel will cause accelerated wear to fuel system parts. The fuel system should be primed prior to starting the engine.

Water in the fuel can cause the engine to run rough. Water in the fuel may cause an electronic unit injector to fail. If the fuel has been contaminated with water, the element should be changed before the regularly scheduled interval.

The primary filter/water separator also provides filtration to help extend the life of the secondary fuel filter. The element should be changed regularly. If a vacuum gauge is installed, the primary filter/water separator should be changed at 50 kPa to 70 kPa (7.25 psi to 10.15 psi).

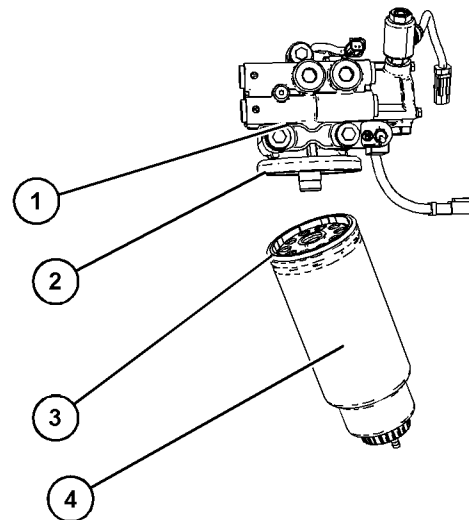

Illustration 47

g06046186

Typical example

- Close the main fuel supply valve.
- Place a suitable container below the primary fuel filter to catch any fluid that may spill. Clean any split fluid.
- Clean the outside of the primary fuel filter.
- Using a suitable tool, remove the spin on filter (4) from filter base (1). Discard old filter element.
- Ensure that the seal surface (2) is clean. Apply clean diesel fuel to the O ring seal (3) on the new spin on filter.
- Install the new spin on filter to the filter base (1). Spin on the filter until the O ring seal (3) contact the sealing surface (2). Then, rotate the spin on filter $\frac{3}{4}$ of a full turn.

7. The secondary fuel filter should be replaced when the primary fuel filter is replaced. For more information refer to this Operation and Maintenance Manual, "Fuel System Secondary Filter - Replace".
8. Dispose of the fluid and old filter in accordance with local regulations.

i06096654

Fuel System Primary Filter/ Water Separator - Drain

WARNING

Fuel leaked or spilled onto hot surfaces or electrical components can cause a fire. To help prevent possible injury, turn the start switch off when changing fuel filters or water separator elements. Clean up fuel spills immediately.

NOTICE

Do not allow dirt to enter the fuel system. Thoroughly clean the area around a fuel system component that will be disconnected. Fit a suitable cover over any disconnected fuel system components.

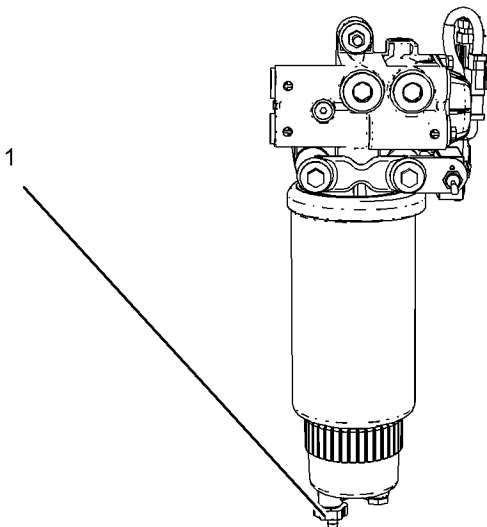

Illustration 48

g03807817

1. Ensure that the engine is stopped. Open drain (1). The drain is a self-ventilated drain. Catch the draining water in a suitable container. Dispose of the water properly.

2. Close drain (3).

NOTICE

The water separator is under suction during normal engine operation. Ensure that the drain valve is tightened securely to help prevent air from entering the fuel system.

i06605835

Fuel System Secondary Filter - Replace

WARNING

Fuel leaked or spilled onto hot surfaces or electrical components can cause a fire. To help prevent possible injury, turn the start switch off when changing fuel filters or water separator elements. Clean up fuel spills immediately.

NOTICE

Do not allow dirt to enter the fuel system. Thoroughly clean the area around a fuel system component that will be disconnected. Fit a suitable cover over any disconnected fuel system components.

NOTICE

Ensure that the engine is stopped before any servicing or repair is performed.

Refer to Systems Operation, Testing, and Adjusting, "Cleanliness of Fuel System Components" for detailed information on the standards of cleanliness that must be observed during ALL work on the fuel system.

1. Turn the fuel supply valve (if equipped) OFF before performing this maintenance.
2. Place a suitable container under the fuel filters to catch any fuel that might spill. Clean up any spilled fuel. Clean the outside body of both fuel filters.

i02348492

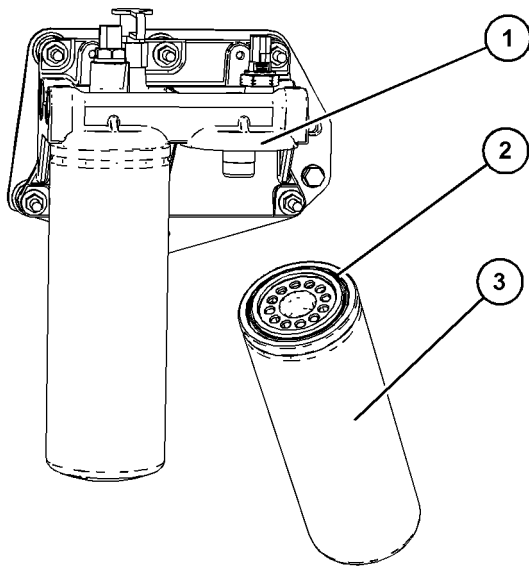

Illustration 49

g06042986

Typical example

Note: The fuel system has two secondary filters, both must be replaced.

3. The residual fuel pressure in the fuel system may need relieving. Wait from 1 minute to 5 minutes until the fuel pressure has lowered.
4. Use a suitable tool remove the spin on fuel filter (3).
5. Ensure the sealing surface (1) is clean. Lubricate the O ring seal (2) on the new spin on filter with clean diesel fuel.
6. Install the new spin on filter (3) to the filter base. Spin on the filter until the O ring seal (2) contact the sealing surface (1). Then, rotate the spin on filter 1 full turn.
7. Replace the other secondary fuel filter, refer to step 2 through to step 6.
8. Turn on the fuel supply valve. Dispose of the fluid and old filters in accordance with local regulations.
9. The primary fuel filter the secondary fuel filter must be replaced at the same time. Refer to the Operation and Maintenance Manual, "Fuel System Primary Filter (Water Separator) Element - Replace". The engine will need to be purged of air. With primary and secondary fuel filters replace, Refer to Operation and Maintenance Manual, "Fuel System Prime".

Fuel Tank Water and Sediment - Drain

NOTICE

Care must be taken to ensure that fluids are contained during performance of inspection, maintenance, testing, adjusting and repair of the product. Be prepared to collect the fluid with suitable containers before opening any compartment or disassembling any component containing fluids.

Dispose of all fluids according to local regulations and mandates.

Fuel Tank

Fuel quality is critical to the performance and to the service life of the engine. Water in the fuel can cause excessive wear to the fuel system.

Water can be introduced into the fuel tank when the fuel tank is being filled.

Condensation occurs during the heating and cooling of fuel. The condensation occurs as the fuel passes through the fuel system and the fuel returns to the fuel tank. This causes water to accumulate in fuel tanks. Draining the fuel tank regularly and obtaining fuel from reliable sources can help to eliminate water in the fuel.

Drain the Water and the Sediment

Fuel tanks should contain some provision for draining water and draining sediment from the bottom of the fuel tanks.

Open the drain valve on the bottom of the fuel tank in order to drain the water and the sediment. Close the drain valve.

Check the fuel daily. Allow five minutes after the fuel tank has been filled before draining water and sediment from the fuel tank.

Fill the fuel tank after operating the engine in order to drive out moist air. This will help prevent condensation. Do not fill the tank to the top. The fuel expands as the fuel gets warm. The tank may overflow.

Some fuel tanks use supply pipes that allow water and sediment to settle below the end of the fuel supply pipe. Some fuel tanks use supply lines that take fuel directly from the bottom of the tank. If the engine is equipped with this system, regular maintenance of the fuel system filter is important.

Fuel Storage Tanks

Drain the water and the sediment from the fuel storage tank at the following intervals:

- Weekly
- Service intervals
- Refill of the tank

This will help prevent water or sediment from being pumped from the storage tank into the engine fuel tank.

If a bulk storage tank has been refilled or moved recently, allow adequate time for the sediment to settle before filling the engine fuel tank. Internal baffles in the bulk storage tank will also help trap sediment. Filtering fuel that is pumped from the storage tank helps to ensure the quality of the fuel. When possible, water separators should be used.

i06223506

Grounding Stud - Inspect/ Clean/Tighten

WARNING

The connection of battery cables to a battery and the disconnection of battery cables from a battery may cause an explosion which may result in injury or death. The connection and the disconnection of other electrical equipment may also cause an explosion which may result in injury or death. The procedures for the connection and the disconnection of battery cables and other electrical equipment should only be performed in a nonexplosive atmosphere.

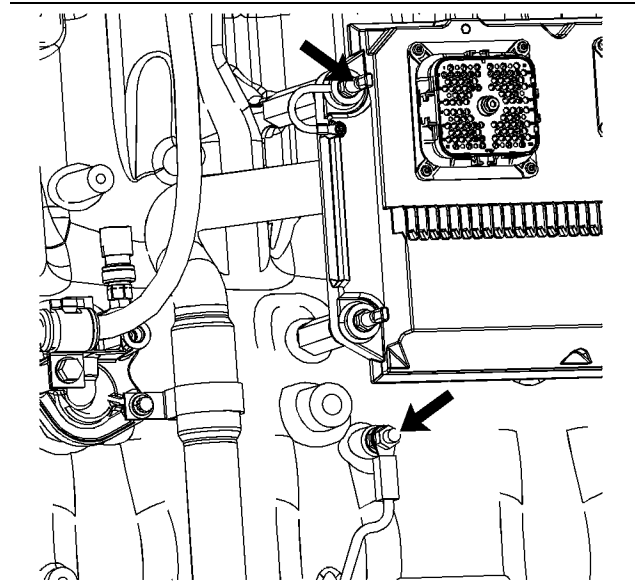

Illustration 50

g03861473

Inspect the OEM harness for good connections. Inspect the condition of the OEM harness.

The electronics grounding studs must have a wire ground to the battery. Tighten the electronics grounding studs at every oil change. Ground wires and straps should be combined at engine grounds. All grounds should be tight and free of corrosion.

- Clean the electronics grounding studs and the terminals for the ground strap with a clean cloth.
- If the connections are corroded, clean the connections with a solution of baking soda and water.
- Keep the electronics grounding studs and the strap clean and coated with MPGM grease or petroleum jelly.

i06223511

Hoses and Clamps - Inspect/ Replace

WARNING

Contact with high pressure fuel may cause fluid penetration and burn hazards. High pressure fuel spray may cause a fire hazard. Failure to follow these inspection, maintenance and service instructions may cause personal injury or death.

If you inspect the engine in operation, always use the proper inspection procedure in order to avoid a fluid penetration hazard. Refer to Operation and Maintenance Manual, "General hazard Information".

Inspect all hoses for leaks that are caused by the following conditions:

- Cracking
- Softness
- Loose clamps

Replace hoses that are cracked or soft. Tighten any loose clamps.

Check for the following conditions:

- End fittings that are damaged or leaking
- Outer covering that is chafed or cut
- Exposed wire that is used for reinforcement
- Outer covering that is ballooning locally
- Flexible part of the hose that is kinked or crushed
- Armoring that is embedded in the outer covering

A constant torque hose clamp can be used in place of any standard hose clamp. Ensure that the constant torque hose clamp is the same size as the standard clamp.

Due to extreme temperature changes, the hose will harden. Hardening of the hoses will cause hose clamps to loosen. This hardening can result in leaks. A constant torque hose clamp will help to prevent loose hose clamps.

Each installation application can be different. The differences depend on the following factors:

- Type of hose
- Type of fitting material
- Anticipated expansion and contraction of the hose
- Anticipated expansion and contraction of the fittings

Replace the Hoses and the Clamps

Refer to the OEM information for further information on removing and replacing fuel hoses (if equipped).

The following text describes a typical method of replacing coolant hoses. Refer to the OEM information for further information on the coolant system and the hoses for the coolant system.

WARNING

Pressurized System: Hot coolant can cause serious burns. To open the cooling system filler cap, stop the engine and wait until the cooling system components are cool. Loosen the cooling system pressure cap slowly in order to relieve the pressure.

1. Stop the engine. Allow the engine to cool.
2. Loosen the cooling system filler cap slowly in order to relieve any pressure. Remove the cooling system filler cap.

Note: Drain the coolant into a suitable, clean container. The coolant can be reused.

3. Drain the coolant from the cooling system to a level that is below the hose that is being replaced.
4. Remove the hose clamps.
5. Disconnect the old hose.
6. Replace the old hose with a new hose.
7. Install the hose clamps with a torque wrench.

Note: For the correct coolant, see this Operation and Maintenance Manual, "Fluid Recommendations".

8. Refill the cooling system. Refer to the OEM information for further information on refilling the cooling system.
9. Clean the cooling system filler cap. Inspect the cooling system filler caps seals. Replace the cooling system filler cap if the seals are damaged. Install the cooling system filler cap.
10. Start the engine. Inspect the cooling system for leaks.

Fuel System

The fuel system is split into two different sections, high pressure, and low pressure. Ensure that the fuel pressure has been purged before any parts are removed loosened or replaced.

Check that connections and hoses are secure, check for leaks. If parts are to be removed or tightened, refer to the Disassembly and Assembly manual for more information.

i05971077

Overhaul Considerations

For an overhaul solution, contact your Perkins distributor.

i03901481

i08254039

Power Take-Off Clutch - Check

NOTICE

New power take-offs should have the clutch adjustment checked before being placed into service. The clutch adjustment should be checked again after the first ten hours of operation. New clutch plates have a "wear in" period, and the clutch may require several adjustments until the new plates are "worn in".

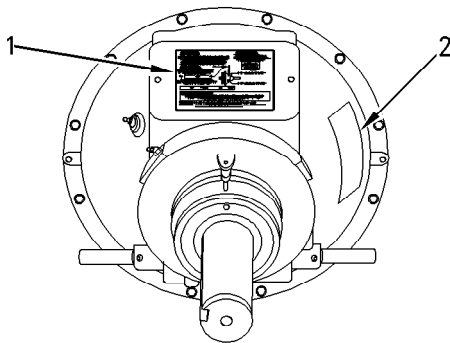

Illustration 51

g00781502

- (1) Instruction plate
(2) Serial number plate

Check the clutch adjustment regularly after "wear in". Heavy-duty applications which have engagements that are frequent and relatively long periods of clutch slippage require more frequent adjustment than light-duty applications. The operating torque should be measured in order to determine if a clutch adjustment is required.

Refer to the OEM information and instruction plate (1) for instructions on lubrication, adjustment, and other recommendations for service. Perform the maintenance that is specified on the instruction plate.

WARNING

Do not operate the engine with the Instruction Plate cover removed from the clutch. Personal injury may result.

If the clutch is damaged to the point of burst failure, expelled pieces can cause personal injury to anyone in the immediate area. Proper safeguards must be followed to help prevent accidents.

Radiator - Clean

Note: Adjust the frequency of cleaning according to the effects of the operating environment.

Inspect the radiator for these items: damaged fins, corrosion, dirt, grease, insects, leaves, oil, and other debris. Clean the radiator, if necessary.

WARNING

Personal injury can result from air pressure.

Personal injury can result without following proper procedure. When using pressure air, wear a protective face shield and protective clothing.

The maximum air pressure for cleaning purposes must be reduced to 205 kPa (30 psi) when the air nozzle is deadheaded.

Pressurized air is the preferred method for removing loose debris. Direct the air in the opposite direction of the air flow. Hold the nozzle approximately 6 mm (0.25 inch) away from the fins. Slowly move the air nozzle in a direction that is parallel with the tubes. This movement will remove debris that is between the tubes.

Pressurized water may also be used for cleaning. The maximum water pressure for cleaning purposes must be less than 275 kPa (40 psi). Use pressurized water to soften mud. Clean the core from both sides.

Use a degreaser and steam for removal of oil and grease. Clean both sides of the core. Wash the core with detergent and hot water. Thoroughly rinse the core with clean water.

After cleaning, start the engine and bring the engine to high idle. This procedure will help in the removal of debris and drying of the core. Stop the engine. Use a light bulb behind the core to inspect the core for cleanliness. Repeat the cleaning, if necessary.

Inspect the fins for damage. Bent fins may be opened with a "comb". Inspect these items for good condition: welds, mounting brackets, air lines, connections, clamps, and seals. Make repairs, if necessary.

i02568202

Starting Motor - Inspect

Perkins recommends a scheduled inspection of the starting motor. If the starting motor fails, the engine may not start in an emergency situation.

Check the starting motor for proper operation. Check the electrical connections and clean the electrical connections. Refer to the Service Manual for more information on the checking procedure and for specifications or consult your Perkins distributors for assistance.

i06223514

Walk-Around Inspection

Inspect the Engine for Leaks and for Loose Connections

A walk-around inspection should only take a few minutes. When the time is taken to perform these checks, costly repairs and accidents can be avoided.

For maximum engine service life, make a thorough inspection of the engine compartment before starting the engine. Look for items such as oil leaks or coolant leaks, loose bolts, worn belts, loose connections, and trash buildup. Make repairs, as needed:

- The guards must be in the correct place. Repair damaged guards or replace missing guards.
- Wipe all caps and plugs before the engine is serviced in order to reduce the chance of system contamination.

NOTICE

For any type of leak (coolant, lube, or fuel) clean up the fluid. If leaking is observed, find the source and correct the leak. If leaking is suspected, check the fluid levels more often than recommended until the leak is found or fixed, or until the suspicion of a leak is proved to be unwarranted.

NOTICE

Accumulated grease and/or oil on an engine or deck is a fire hazard. Remove this debris with steam cleaning or high pressure water.

- Ensure that the cooling lines are correctly clamped and that the cooling lines are tight. Check for leaks. Check the condition of all pipes.
- Inspect the water pumps for coolant leaks.

Note: The water pump seal is lubricated by coolant in the cooling system. A small amount of leakage is normal as the engine cools down and the parts contract.

Excessive coolant leakage may indicate the need to replace the water pump seal. For the removal of water pumps and the installation of water pumps and/or seals, refer to the Service Manual for the engine or consult your Perkins distributor.

- Inspect the lubrication system for leaks at the front crankshaft seal, the rear crankshaft seal, the oil pan, the oil filters, and the valve cover.
- Inspect the fuel system for leaks. Look for loose fuel line clamps or for loose fuel line tie-wraps.
- Inspect the piping for the air inlet system and the elbows for cracks and for loose clamps. Ensure that hoses and tubes are not contacting other hoses, tubes, and wiring harnesses.
- Inspect the alternator belt and the accessory drive belts for cracks, breaks, or other damage.

Belts for multiple groove pulleys must be replaced as matched sets. If only one belt is replaced, the belt will carry more load than the belts that are not replaced. The older belts are stretched. The additional load on the new belt could cause the belt to break.

- Drain the water and the sediment from fuel tanks on a daily basis in order to ensure that only clean fuel enters the fuel system.
- Drain the water from the primary fuel filter.
- Inspect the wiring and the wiring harnesses for loose connections and for worn wires or frayed wires.
- Inspect the ground strap for a good connection and for good condition.
- Inspect the ECM to the cylinder head ground strap for a good connection and for good condition.
- Disconnect any battery chargers that are not protected against the current drain of the starting motor. Check the condition and the electrolyte level of the batteries, unless the engine is equipped with a maintenance free battery.
- Check the condition of the gauges. Replace any gauges that are cracked. Replace any gauge that cannot be calibrated.

i06223521

Water Pump - Inspect

A failed water pump might cause severe engine overheating problems that could result in the following conditions:

- Cracks in the cylinder head

- A piston seizure
- Other potential damage to the engine

A failed water pump might cause severe engine overheating problems. Overheating could result in cracks in the cylinder head, a piston seizure, or other potential damage to the engine.

Visually inspect the water pump for leaks. If leaking of the water pump seals is observed, replace the water pump. Refer to Disassembly and Assembly, "Water Pump - Remove" and Disassembly and Assembly, "Water Pump - Install" for the correct procedure.

Inspect the water pump for wear, cracks, pin holes, and proper operation. Refer to the Parts Manual for the correct part numbers for the engine or consult a Perkins distributor if a repair or replacement is needed.

Index

A

After Starting Engine	35
After Stopping Engine	40
Air Compressor - Check (If Equipped)	61
Air Tank Moisture and Sediment - Drain (If Equipped)	62

B

Battery - Recycle	62
Battery - Replace	62
Battery Electrolyte Level - Check	63
Battery or Battery Cable - Disconnect	63
Before Starting Engine	14, 32
Belts - Inspect/Adjust/Replace	64
Adjust	64
Inspect	64
Replace	64
Burn Prevention	11
Batteries	12
Coolant	11
Diesel Fuel	12
Oils	12

C

Cold Weather Operation	38
Cold Weather Starting	32
Ether Injection System (If Equipped)	33
Coolant (DEAC) - Change	64
Drain	65
Fill	65
Flush	65
Coolant (ELC) - Change	66
Drain	66
Fill	67
Flush	66
Coolant Extender (ELC) - Add	67
Coolant Level - Check	67
Coolant Temperature Regulator - Replace	68
Cooling System Supplemental Coolant Additive (SCA) - Test/Add	68
Add the SCA, If Necessary	69
Test for SCA Concentration	69
Crushing Prevention and Cutting Prevention ..	14

D

Diagnostic Lamp	30
-----------------------	----

Driven Equipment - Check	69
--------------------------------	----

E

Electrical System	15
Grounding Practices	16
Electronic Unit Injector - Check/Replace	69
Emissions Certification Film	21
Engaging the Driven Equipment	36
Industrial Engines	36
Engine - Clean	70
Engine Air Cleaner Element (Dual Element) - Inspect/Clean/Replace	70
Cleaning the Primary Air Cleaner Elements	71
Servicing the Air Cleaner Elements	70
Engine Air Cleaner Element (Single Element) - Inspect/Clean/Replace	72
Engine Air Cleaner Service Indicator - Inspect (If Equipped)	73
Test the Service Indicator	73
Engine Diagnostics	30
Engine Electronics	16
Engine Mounts - Inspect	74
Engine Oil and Filter - Change	75
Drain the Engine Lubricating Oil	76
Fill the Oil Pan	77
Oil and Filter Change Intervals	76
Engine Oil Level - Check	74
Engine Oil Sample - Obtain	75
Obtain the Sample and the Analysis	75
Engine Operation	36
Engine Operation with Active Diagnostic Codes	30
Engine Operation with Intermittent Diagnostic Codes	31
Engine Starting	15, 32
Engine Stopping	15, 40
Engine Valve Lash - Check	77
Engine Valve Rotators - Inspect	78

F

Fault Logging	30
Features and Controls	26
Fire Prevention and Explosion Prevention	12
Ether	14
Fire Extinguisher	14
Lines, Tubes, and Hoses	14

Fluid Recommendations	41, 52	General Information	17
ELC Cooling System Maintenance.....	54	Grounding Stud - Inspect/Clean/Tighten.....	83
Engine Oil	42		
General Coolant Information	52	H	
General Lubricant Information.....	41	Hoses and Clamps - Inspect/Replace.....	83
Fluid Recommendations (General Fuel		Fuel System.....	84
Information)	43	Replace the Hoses and the Clamps	84
Contamination Control Recommendations for			
Fuels	51	I	
Diesel Fuel Characteristics.....	46	Important Safety Information.....	2
Diesel Fuel Requirements	44		
General Information.....	44	L	
Renewable and Alternative Fuels.....	51	Lifting and Storage	22
Foreword	4		
California Proposition 65 Warning.....	4	M	
Literature Information	4	Maintenance Interval Schedule.....	60
Maintenance	4	Daily.....	60
Maintenance Intervals	5	Every 12 000 Service Hours or 6 Years.....	60
Operation	4	Every 2500 Service Hours.....	60
Overhaul	5	Every 3000 Service Hours or 2 Years	60
Safety.....	4	Every 4000 Service Hours.....	60
Fuel and the Effect from Cold Weather	38	Every 500 Service Hours.....	60
Fuel Conservation Practices	36	Every 500 Service Hours or 1 Year	60
Fuel Related Components in Cold Weather ...	38	Every 585,000 L (154,540 US gal) of Fuel ..	60
Fuel Heaters	39	Every 6000 Service Hours or 3 Years	60
Fuel Tanks	38	When Required.....	60
Fuel System - Prime (General Instructions)....	78	Maintenance Recommendations	57
Electrically Operated Priming Pump.....	79	Maintenance Section.....	41
Mechanical Operated Hand Priming		Manual Stop Procedure	40
Pump.....	79	Model View Illustrations	17
Original Equipment Manufacture.....	80	Engine Views	17
Priming Fuel Pumps	79	Monitoring System.....	26
Fuel System Primary Filter (Water		Action Alert	26
Separator) Element - Replace.....	80	Critical Protection Override.....	26
Fuel System Primary Filter/Water		Diagnostic	27
Separator - Drain	81	Shutdown.....	26
Fuel System Secondary Filter - Replace	81	Shutdown Reset	27
Fuel Tank Water and Sediment - Drain	82	Standard Warning Outputs	27
Drain the Water and the Sediment	82	Warning Alarm	26
Fuel Storage Tanks.....	83	Mounting and Dismounting	14
Fuel Tank	82		
		O	
G		Operation Section.....	22
General Hazard Information.....	8	Overhaul Considerations.....	84
Containing Fluid Spillage.....	10		
Dispose of Waste Properly	11	P	
Fluid Penetration	9	Plate Locations and Film Locations	21
Inhalation	10		
Pressurized Air and Water.....	9		
Static Electricity Hazard when Fueling with			
Ultra-low Sulfur Diesel Fuel	10		

Power Take-Off Clutch - Check	85	T	
Product Description	19	Table of Contents	3
Aftermarket Products and Perkins		W	
Engines	20	Walk-Around Inspection	86
Electronic Engine Features	20	Inspect the Engine for Leaks and for Loose	
Engine Diagnostics	20	Connections	86
Engine Service Life	20	Water Pump - Inspect	86
Engine Specifications	19	Welding on Engines with Electronic	
Product Identification Information	21	Controls	57
Product Information Section	17		
Product Lifting	22		
Engine Lifting	23		
Product Storage	23		
Engine	23		
R			
Radiator - Clean	85		
Radiator Restrictions	38		
Refill Capacities	41		
Refill Capacities and Recommendations	41		
Recommendation	41		
Refill Capacities	41		
S			
Safety Messages	6		
2506D-E15TA Safety Label Positions	6		
Universal Warning (1)	7		
Safety Section	6		
Self-Diagnostics	30		
Sensors and Electrical Components	27		
Severe Service Application	58		
Environmental Factors	59		
Incorrect Maintenance Procedures	59		
Incorrect Operating Procedures	59		
Starting Motor - Inspect	85		
Starting the Engine	33		
Problems with the Wiring Harness	34		
Starting Problems	33		
Starting the Engine	33		
Starting with Jump Start Cables (Do Not			
Use This Procedure in Hazardous			
Locations that have Explosive			
Atmospheres)	34		
Stopping the Engine	40		
System Pressure Release	57		
Coolant System	57		
Engine Oil	57		
Fuel System	57		

Product and Dealer Information

Note: For product identification plate locations, see the section "Product Identification Information" in the Operation and Maintenance Manual.

Delivery Date: _____

Product Information

Model: _____

Product Identification Number: _____

Engine Serial Number: _____

Transmission Serial Number: _____

Generator Serial Number: _____

Attachment Serial Numbers: _____

Attachment Information: _____

Customer Equipment Number: _____

Dealer Equipment Number: _____

Dealer Information

Name: _____ Branch: _____

Address: _____

Dealer Contact

Phone Number

Hours

Sales: _____

Parts: _____

Service: _____

M0080243
©2020 Perkins Engines Company Limited
All Rights Reserved