



Cat[®]

CB22B, CB24B, CB24B XT CB32B, CC24B

UTILITY COMPACTORS

FEATURES:

■ Simple Operation

- Easy access due to logically placed handles and lower platform height
- Sliding seat and spacious platform provide comfort and control
- Dual propel lever option enhances control from either side
- Intuitive, multi-function control panel with vandal protection enables good performance
- Easy viewing LCD display and vibrant LED lights on the control panel simplify operation for both day and night operation
- Easy folding ROPS and canopy, can be lowered without tools

■ Efficient Compaction Performance

- Excellent drum-edge visibility due to longitudinal engine mount and narrow frame design; improves control for better coverage and compaction results
- Increased drum diameter for smoother compaction performance
- High amplitude and three frequency selections deliver excellent compaction results and lower sound levels
- 50 mm (2") drum offset capability enhances control near curbs and other obstacles while offering more coverage
- Ballast options increase flexibility and compaction performance
- Extended 3 year/3,000 hour vibratory drum maintenance interval minimizes lifetime operating costs
- CC24B is equipped with pneumatic tires that provide a kneading action for a tight mat finish

■ Best-in-Class Water Spray System

- 235 L (62 gal) water tank can last up to 10 hours without refilling
 - * Note: CC24B water tank capacity is 195 L (52 gal)
- Variable spray modes optimize water usage
- Triple filtration delivers reliable performance and simplifies service
- Self-adjusting, spring-loaded scrapers keep the drum clean, distribute water, and lower water consumption
- Anti-freeze option provides protection in cool weather
- Single drain port simplifies service requirements

■ Optimized Power

- Powerful Cat C1.5 engine
- Eco-mode and electronic engine control reduce fuel consumption
- Traction control option, pin-on design offers quick installation
- Fast travel speed of 12.5 kph (8 mph) for good mobility
 - * Note: CC24B maximum travel speed is 10.5 kph (6.5 mph)

■ Designed for Rental

- Easy operation with intuitive controls
- Extensive legroom to suit a variety of operators
- Durable components maximize uptime and lower lifetime operating costs
- Fuel efficient engine
- Low sound levels for nighttime operation
- Product Link™ ready for simple remote monitoring

- 1 Intuitive Console with LCD Display
- 2 Narrow Frame Design Enhances Visibility
- 3 Eco-mode
- 4 Roomy Operating Environment
- 5 Dual Propel Lever (Option)
- 6 Ballast Addition (Option)
- 7 50 mm (2") Drum Offset
- 8 Reliable Water Spray System
- 9 Foldable ROPS and Canopy (Options)



CB22B, CB24B, CB24B XT, CB32B, CC24B Utility Compactors

Specifications

		CB22B	CB24B	CB24B XT	CB32B	CB32B w/Ballast	CC24B
Cat C1.5 Engine - kW (hp)						24.4 (32.7)*	
Operating Weight - kg (lb)		2553 (5,629)	2723 (6,003)	3123 (6,885)	2808 (6,190)	3208 (7,071)	2441 (5,380)
Max. Operating Weight - kg (lb)		2731 (6,020)	2901 (6,395)	3301 (7,276)	2985 (6,581)	3385 (7,462)	2618 (5,772)
Static Linear Load - kg/cm (pli)		12.8 (72)	11.3 (63)	13.0 (73)	10.8 (61)	12.3 (69)	10.2 (57)
Amplitude - mm (in)						0.53 (0.021)	
Frequency - Hz (vpm)						63/52/42 (3,780/3,120/2,520)	
Centrifugal Force - kN (lbf)	High	28.8 (6,475)	34.7 (7,801)	34.7 (7,801)	37.1 (8,340)	37.1 (8,340)	34.7 (7,801)
	Med	19.6 (4,406)	23.7 (5,328)	23.7 (5,328)	25.3 (5,688)	25.3 (5,688)	23.7 (5,328)
	Low	12.8 (2,878)	15.4 (3,462)	15.4 (3,462)	16.5 (3,709)	16.5 (3,709)	15.4 (3,462)

*Meets Brazil MAR-1 emission standards

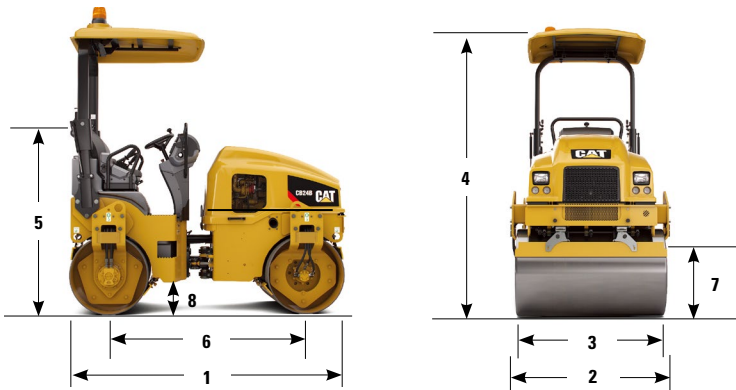

OPTIONAL EQUIPMENT

- Antifreeze-ready, (water spray)
- Ballast
- Battery disconnect switch
- Bio-hydraulic oil
- Canopy, fixed
- Canopy, folding
- Cup holders
- Dual propel levers
- LED Lights
- Non-suspension seat
- Product Link
- ROPS, fixed
- ROPS, foldable
- Suspension seat w/safety switch
- Sliding seat
- Traction control (not available on CC24B)

Dimensions

	CB22B	CB24B	CB24B XT	CB32B	CC24B
1 Overall length - mm (in)	2575 (101)	2575 (101)	2575 (101)	2575 (101)	2575 (101)
2 Overall width - mm (in)	1112 (44)	1312 (52)	1312 (52)	1412 (56)	1312 (52)
3 Drum width - mm (in)	1000 (39")	1200 (47)	1200 (47)	1300 (51)	1200 (47)
Drum offset - mm (in)	50 (2)	50 (2)	50 (2)	50 (2)	50 (2)
Drum shell thickness - mm (in)	14 (0.6)	14 (0.6)	14 (0.6)	14 (0.6)	14 (0.6)
Drum diameter - mm (in)	720 (28)	720 (28)	720 (28)	720 (28)	720 (28)
4 Height at ROPS/FOPS wo/canopy - mm (in)	2595 (102)	2595 (102)	2595 (102)	2595 (102)	2595 (102)
Height at ROPS/FOPS w/canopy - mm (in)	2700 (106)	2700 (106)	2700 (106)	2700 (106)	2700 (106)
5 Transport height (w/foldable ROPS) - mm (in)	1800 mm (71)	1800 mm (71)	1800 mm (71)	1800 mm (71)	1800 mm (71)
6 Wheelbase - mm (in)	1800 mm (71)	1800 mm (71)	1800 mm (71)	1800 mm (71)	1800 mm (71)
7 Curb clearance - mm (in)	500 mm (20)	500 mm (20)	500 mm (20)	500 mm (20)	500 mm (20)
8 Ground clearance - mm (in)	285 mm (11)	285 mm (11)	285 mm (11)	285 mm (11)	285 mm (11)



For more complete information on Cat products, dealer services, and industry solutions, visit us on the web at www.cat.com

QEHQ2275 (11/16)

Materials and specifications are subject to change without notice. Featured machines in photos may include additional equipment.

©2016 Caterpillar Inc.
All Rights Reserved.

CAT, CATERPILLAR, ACERT, BUILT FOR IT, SAFETY.CAT.COM, their respective logos, "Caterpillar Yellow" and the "Power Edge" trade dress, as well as corporate and product identity used herein, are trademarks of Caterpillar and may not be used without permission.

