



# Cat® CW34

## Pneumatic Tire Roller

### Top Features

The Cat® CW34 is an eight wheel pneumatic roller that features a modular ballast system and flexible operating weight of 8625 kg to 27 000 kg (19,015 lb - 59,525 lb). It offers excellent visibility, Eco-mode operation, even compaction, and excels on a variety of materials due to its flexible air-on-the-run capability.

- **Exceptional Visibility and Control** with sliding and rotating operator's station, LCD display, touch-pad machine functions, and optional Compaction Control. Cab or ROPS options are available.
- **Smooth Operating Powertrain** with electronic propel control and smooth braking system. The three speed hydrostatic propel system delivers excellent gradeability with speeds up to 19 km/hr (11.8 mph).
- **Versatile Compaction Performance** due to the flexible ballast system, oscillating front wheels, and optional air-on-the-run. Flexible ballast options include modular steel, factory installed internal steel, sand, and water. The modular steel ballast system can be easily added or removed, making it easy to adjust operating weights and match job site requirements.
- **Cat Compaction Control** keeps the operator informed for higher performance and efficiency. Infrared temperature sensors combined with mapping keep the operator informed of when optimal conditions exist and where compaction has taken place. Temperature Mapping records data for future analysis, while Pass-Count Mapping keeps the operator informed of the number of passes made.
- **Best Lifetime Value** with Eco-mode operation, efficient engine, and durable rubber tires minimize life-time operating costs and maximize profit.

### Specifications

#### Weights

CW34*	Operating Weight		Load per Wheel
w/Sun canopy	8625 kg	19,015 lb	1.07 mt
w/ROPS	9000 kg	19,842 lb	1.12 mt
w/Cab - ROPS/FOPS	9650 kg	21,275 lb	1.20 mt
w/Water	12 000 kg	26,455 lb	1.50 mt
w/Internal steel and water	13 500 kg	29,762 lb	1.68 mt
w/Internal steel and water	14 000 kg	30,865 lb	1.75 mt
w/Modular steel and water	15 000 kg	33,069 lb	1.87 mt
w/Modular steel	15 600 kg	34,392 lb	1.95 mt
w/Internal steel and water	16 000 kg	35,275 lb	2.00 mt
w/Modular steel, internal steel, and water	16 000 kg	35,275 lb	2.00 mt
w/Modular steel, internal steel	18 000 kg	39,683 lb	2.25 mt
w/Modular steel and water	18 600 kg	41,006 lb	2.32 mt
w/Modular steel, internal steel, and water	20 000 kg	44,092 lb	2.50 mt
w/Modular steel, internal steel, and water	24 000 kg	52,911 lb	3.00 mt
w/Modular steel, internal steel, and water	27 000 kg	59,525 lb	3.38 mt

#### Engine – Powertrain

Engine Model	Cat C4.4 w/ACERT™ Technology	
Number of Cylinders	4	
Rated Speed	2200 rpm	
Bore	105 mm	4.13"
Stroke	127 mm	5"
Gross Power:	<i>Engine meets Brazil MAR-1 emission standards</i>	
	96.5 kW	129 hp (I)
		131.2 hp (m)
Speed Ranges:		
Low	0 - 6 km/hr	4 mph
Medium	0 - 12 km/hr	7 mph
High	0 - 19 km/hr	12 mph

\* Weights shown include ROPS (unless otherwise stated), 80 kg (176 lb) operator, full capacity fuel tank, full capacity water tank, and all machine options. Weights are approximate and may vary by market due to standard and optional equipment requirements. Water and sand ballast are not supplied by the manufacturer.



# CW34 Pneumatic Tire Roller

## Dimensions

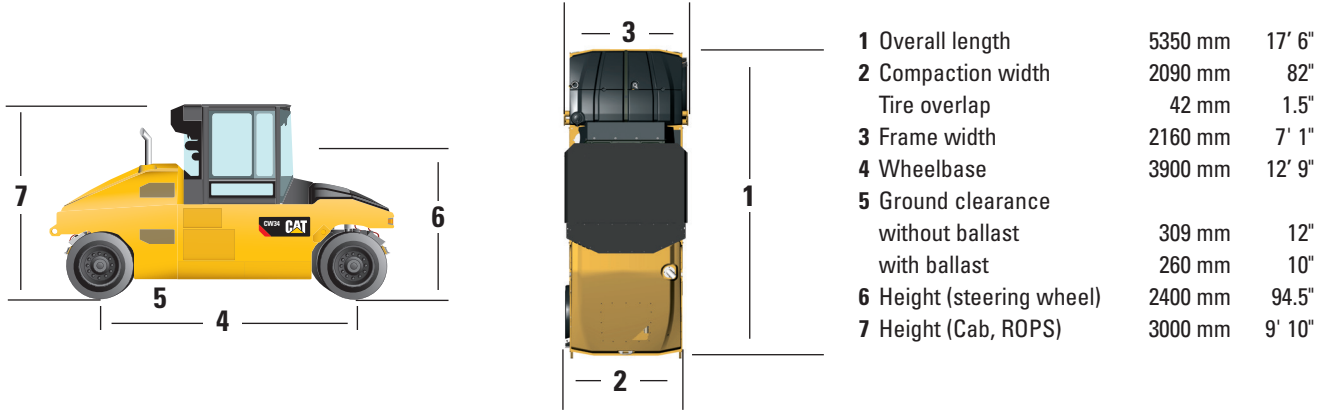

## Ground Contact Pressures

		Weight per Wheel							
Tire Pressure		300 kPa 44 psi	400 kPa 58 psi	500 kPa 73 psi	600 kPa 87 psi	700 kPa 102 psi	800 kPa 116 psi	850 kPa 123 psi	900 kPa 131 psi
Average Wheel Load	1500 kg 3,307 lb	242 kPa 35 psi	309 kPa 45 psi	406 kPa 59 psi	612 kPa 89 psi	680 kPa 99 psi	1038 kPa 151 psi	1265 kPa 184 psi	1587 kPa 230 psi
	2000 kg 4,410 lb	260 kPa 38 psi	299 kPa 43 psi	357 kPa 52 psi	462 kPa 67 psi	498 kPa 72 psi	628 kPa 91 psi	691 kPa 100 psi	764 kPa 111 psi
	2500 kg 5,512 lb	308 kPa 45 psi	322 kPa 47 psi	360 kPa 52 psi	429 kPa 62 psi	458 kPa 66 psi	539 kPa 78 psi	577 kPa 84 psi	618 kPa 90 psi
	3000 kg 6,614 lb	397 kPa 58 psi	369 kPa 54 psi	386 kPa 56 psi	433 kPa 63 psi	457 kPa 66 psi	516 kPa 75 psi	543 kPa 79 psi	573 kPa 83 psi
	3375 kg 7,441 lb	518 kPa 75 psi	423 kPa 61 psi	418 kPa 61 psi	448 kPa 65 psi	469 kPa 68 psi	517 kPa 75 psi	539 kPa 78 psi	564 kPa 82 psi

## Standard Equipment

- 24-Volt Electrical System
- 3 m³ Water Tight Ballast Chamber
- 13/80-R20 Tires
- 100 Amp Alternator
- Eco-mode
- Front Wheel Suspension
- Halogen Working Lights
- LCD Operating Display
- Product Link™ Ready
- Pressurized Water Spray w/Triple Filtration
- Roading Lights
- Sliding Station w/180° Rotation
- Three-Speed Propel System
- Vinyl Seat with 76 mm (3") Wide Belt
- Wheel Oscillation, (front and rear)

## Service Refill Capacities

Fuel Tank	270 L	71 gal
Cooling System	27 L	7 gal
Engine Oil	9 L	2.4 gal
Hydraulic Tank	32 L	8.5 gal
Water Tank	380 L	100 gal
Emulsion Tank	40 L	10.5 gal



For more complete information on Cat products, dealer services, and industry solutions, visit us on the web at [www.cat.com](http://www.cat.com)

QEHQ2274-01 (08-2020)

© 2020 Caterpillar  
All Rights Reserved

Materials and specifications are subject to change without notice. Featured machines in photos may include additional equipment. See your Cat dealer for available options.

CAT, CATERPILLAR, SAFETY.CAT.COM, their respective logos, "Caterpillar Corporate Yellow" and the "Power Edge" trade dress, as well as corporate and product identity used herein, are trademarks of Caterpillar and may not be used without permission.

