

Image shown may not reflect actual configuration

Caterpillar is leading the power generation marketplace with Power Solutions engineered to deliver unmatched flexibility, expandability, reliability, and cost-effectiveness.

## Specifications

Generator Set Specifications	
Minimum Rating	808 ekW (1010 kVA)
Maximum Rating	880 ekW (1100 kVA)
Voltage	415 Volts
Frequency	50 Hz
Speed	1500 rpm

Generator Set Configurations	
Emissions/Fuel Strategy	Low Fuel Consumption

Engine Specifications	
Engine Model	C32 ACERT™ TA, V-12, 4-stroke Water-cooled Diesel
Bore	145 mm
Displacement	32.1 L
Stroke	162 mm
Compression Ratio	15.0:1
Aspiration	Turbocharged Aftercooled
Governor Type	ADEM™ A4
Fuel System	MEUI™



## Benefits & Features

### Cat® Diesel Engine

- Reliable, rugged, durable design
- Field-proven in thousands of applications worldwide
- Four-stroke-cycle diesel engine combines consistent performance and excellent fuel economy with minimum weight

### Generator

- Matched to the performance and output characteristics of Cat engines
- Industry-leading mechanical and electrical design
- Industry-leading motor starting capabilities
- High efficiency

### Cat EMCP Control Panel

The EMCP controller features the reliability and durability you have come to expect from your Cat equipment. EMCP 4 is a scalable control platform designed to ensure reliable generator set operation, providing extensive information about power output and engine operation. EMCP 4 systems can be further customized to meet your needs through programming and expansion modules.

## **Standard Equipment**

### **Air Inlet**

- Air cleaner

### **Cooling**

- Package-mounted radiator

### **Exhaust**

- Exhaust muffler
- Exhaust flange outlet

### **Fuel**

- Primary fuel filter with integral water separator
- Secondary fuel filter
- Fuel priming pump

### **Generator**

- Matched to the performance and output characteristics of Cat engines
- Load adjustment module provides engine relief upon load impact and improves load acceptance and recovery time
- IP23 protection

### **Power Termination**

- Bus bar

### **Control Panel**

- EMCP 4.2 generator set controller

### **Mounting**

- Rubber anti-vibration mounts

### **Starting/Charging**

- Charging alternator

### **General**

- 990 liter fuel tank
- Paint – Caterpillar Yellow except rails and radiator black

## **Optional Equipment**

### **Generator**

- Winding and bearing temperature detectors
- Anti-condensation heater
- Oversize and premium generators

### **Control Panels**

- EMCP 4.3 and EMCP 4.4
- Generator temperature monitoring and protection
- Load share module
- Digital I/O module
- Remote monitoring software

### **Starting/Charging**

- Jacket water heater

### **General**

- The following options are based on regional and product configuration:
  - Heavy-duty air cleaner
  - Option for remote mounting of UIP
  - Circuit breaker panel

**C32 ACERT™**  
808 ekW/ 1010 kVA/ 50 Hz/ 1500 rpm/ 415V/ 0.8 Power Factor

Rating Type: PRIME

Fuel Strategy: Low Fuel Consumption

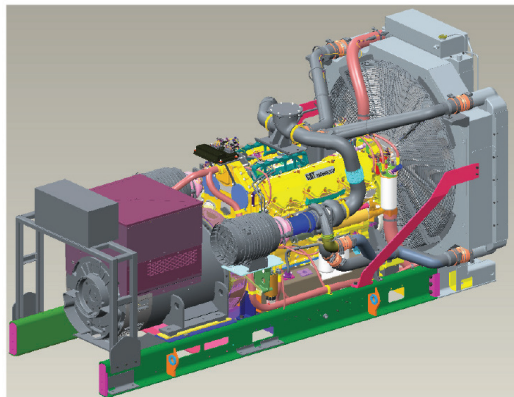

**C32 ACERT**  
808 ekW/ 1010 kVA  
50 Hz/ 1500 rpm/ 415V

Image shown may not reflect actual configuration

<b>Package Performance</b>	
Generator Set Power Rating with Fan @ 0.8 Power Factor	808 ekW
Generator Set Power Rating	1010 kVA
Aftercooler (separate circuit)	Air-to-Air

<b>Fuel Consumption</b>	
100% Load	207.5 L/hr
75% Load	156.8 L/hr
50% Load	109.3 L/hr
25% Load	65.1 L/hr

<b>Cooling System</b>	
Engine Coolant Capacity	55.0 L
Coolant Capacity with Radiator	100 L
<b>Inlet Air</b>	
Combustion Air Inlet Flow Rate	62.2 m <sup>3</sup> /min
Max. Allowable Combustion Air Inlet Temp	47°C

**C32 ACERT™  
808 ekW/ 1010 kVA/ 50 Hz/ 1500 rpm/ 415V/ 0.8 Power Factor**

**Rating Type: PRIME**

**Fuel Strategy: Low Fuel Consumption**

<b>Exhaust System</b>	
Exhaust Stack Gas Temperature	498.3°C
Exhaust Gas Flow Rate	166.2 m³/min
Exhaust System Backpressure (maximum allowable)	10.0 kPa

<b>Heat Rejection</b>	
Heat Rejection to Jacket Water	301 kW
Heat Rejection to Exhaust (total)	749 kW
Heat Rejection to Aftercooler	155 kW
Heat Rejection to Atmosphere from Engine	108 kW
Heat Rejection to Atmosphere from Generator	41 kW

<b>Alternator<sup>2</sup></b>	
Motor Starting Capability @ 30% Voltage Dip	2297 skVA
Current	1407 amps
Frame Size	1402
Excitation	IE
Temperature Rise	125°C

<sup>1</sup> For ambient and altitude capabilities consult your Cat dealer. Air flow restriction (system) is added to existing restriction from factory.

<sup>2</sup> Generator temperature rise is based on a 40°C (104°F) ambient per NEMA MG1-32.

**C32 ACERT™**  
**808 ekW/ 1010 kVA/ 50 Hz/ 1500 rpm/ 415V/ 0.8 Power Factor**

**Rating Type: PRIME**

**Fuel Strategy: Low Fuel Consumption**

## **DEFINITIONS AND CONDITIONS**

### **Applicable Codes and Standards:**

ISO3046, ISO8528, IEC60034-1, IS4722.

Note: Codes may not be available in all model configurations. Please consult your local Cat dealer representative for availability.

**PRIME:** Output available with varying load for unlimited time. Prime power in accordance with ISO 8528. 10% overload power in accordance with ISO 3046.

**Ratings** are based on SAE J1349 standard conditions. These ratings also apply at ISO 3046 standard conditions.

**Fuel Rates** are based on fuel oil of 35° API [16°C] gravity having an LHV of 42 780 kJ/kg when used at 29°C and weighing 838.9 g/liter.

Additional ratings may be available for specific customer requirements, contact your Cat representative for details. For information regarding low sulfur fuel and biodiesel capability, please consult your Cat dealer.

Performance No.: DM9957-02  
Generator Arrangement:4326118  
Date: 08/11/2016  
Source Country: India

LEHE0950-03

[www.Cat-ElectricPower.com](http://www.Cat-ElectricPower.com)

©2016 Caterpillar  
All rights reserved.

Materials and specifications are subject to change without notice.  
The International System of Units (SI) is used in this publication.

CAT, CATERPILLAR, their respective logos, ADEM, ACERT, MEUI, "Caterpillar Yellow", the "Power Edge" trade dress as well as corporate and product identity used herein, are trademarks of Caterpillar and may not be used without permission.