

374F L

Hydraulic Excavator

2017



Engine

| | | |
|-------------------|-----------------|--------|
| Engine Model | Cat® C15 ACERT™ | |
| Power – ISO 14396 | 362 kW | 485 hp |
| Power – ISO 9249 | 352 kW | 472 hp |

Drive

| | | |
|----------------------|----------|-------------|
| Maximum Travel Speed | 4.1 km/h | 2.6 mph |
| Maximum Drawbar Pull | 492 kN | 110,500 lbf |

Operating Weights

| | | |
|---------|-----------|------------|
| Minimum | 70 975 kg | 156,500 lb |
| Maximum | 75 170 kg | 165,700 lb |

The 374F L is built to keep your production numbers up and your owning and operating costs down.

Not only does the machine's C15 ACERT engine meet U.S. EPA Tier 2, EU Stage II, Japan 2001 (Tier 2) equivalent or U.S. EPA Tier 3, Stage IIIA, Japan 2006 (Tier 3) equivalent, China Nonroad Stage III emission standards, but it does so while giving you all the power, fuel efficiency, and reliability you need to succeed.

Where the real power comes in is through advanced hydraulics and the new Adaptive Control System (ACS) valve. The ACS valve and other integrated components allow you to move tons of material all day long with a great deal of speed, precision, and efficiency. In fact, the hydraulic system and engine team worked together to lower fuel consumption up to 28% – with zero impact on your productivity – compared to 374D L.

When you add in a quiet operator environment that keeps you comfortable and productive, service points that make your routine maintenance quick and easy, and multiple Cat work tools that help you do a number of jobs very well, you simply won't find a better machine in this size class.



Contents

| | |
|-------------------------------|----|
| Fuel Efficient | 4 |
| Easy to Operate | 6 |
| Durable Structures | 8 |
| Durable Linkages | 9 |
| Versatile | 10 |
| Cat Connect Technologies..... | 12 |
| Reliable and Productive | 14 |
| Safe Work Environment | 15 |
| Serviceable | 16 |
| Complete Customer Care..... | 17 |
| Sustainable | 17 |
| Specifications..... | 18 |
| Standard Equipment..... | 34 |
| Optional Equipment..... | 35 |



Fuel Efficient

Engineered to lower your operating costs



The Cat C15 ACERT engine meets U.S. EPA Tier 2, EU Stage II, Japan 2001 (Tier 2) equivalent or U.S. EPA Tier 3, Stage IIIA, Japan 2006 (Tier 3) equivalent, China Nonroad Stage III emission standards and it does so without interrupting your job process. Simply turn the engine on and go to work. It will look for opportunities in your work cycle to regenerate itself, and it will give you plenty of power for the task at hand – all to help keep your owning and operating costs to an absolute minimum.

A Smart Design for Any Temperature

The 374F L features a side-by-side cooling system that allows you to put the machine to work in extremely hot and cold conditions. The system is completely separated from the engine compartment to reduce noise and heat. Plus it features easy-to-clean cores and a new variable-speed fan that reverses to blow out unwanted debris that may accumulate during your work day.

Biodiesel Not A Problem

The C15 ACERT engine can run on biodiesel fuel. Just fill it up and go.

Proven Technology

The right technologies fine-tuned for the right applications result in:

- **Improved Fuel Efficiency – Up to 28% improvement over previous emissions products.**
- **High Performance** across a variety of applications.
- **Enhanced Reliability** through commonality and simplicity of design.
- **Maximized Uptime and Reduced Cost** with world-class support from the Cat Dealer network.
- **Minimized Impact of Emission Systems** – designed to be transparent to the operator without requiring interaction.
- **Durable designs** with long life to overhaul.
- **Delivering better fuel economy** with minimized maintenance costs while providing the same great power and response.

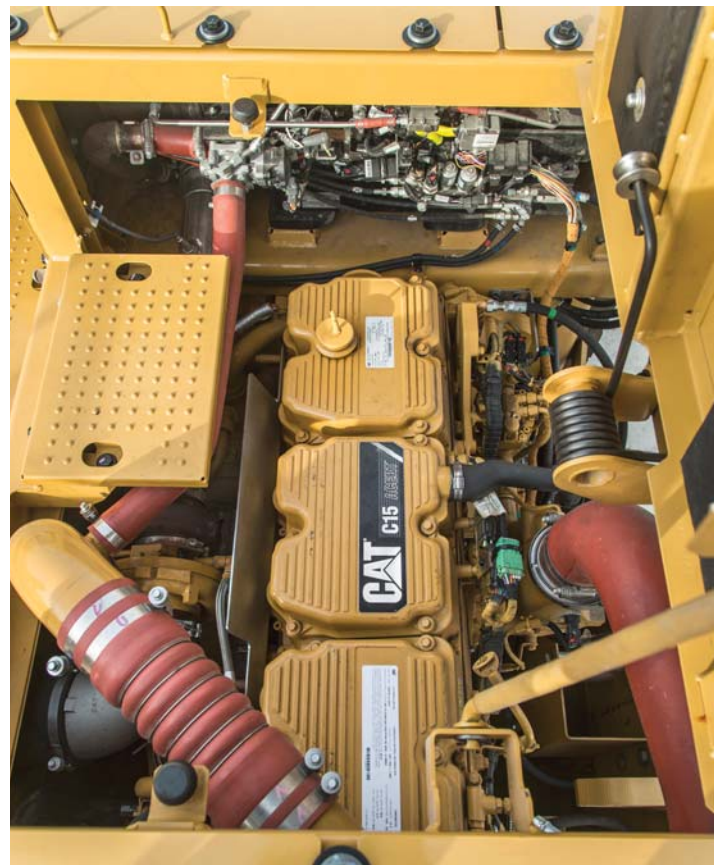

Easy to Operate

Comfort and convenience to keep you productive all day long



Safe and Quiet Cab

The cab contributes to your comfort thanks to special viscous mounts and special roof lining and sealing, that limit vibration and unnecessary sound.

Operators will enjoy the quietness and comfort of the all-new cab that's insulated to reduce sound inside by 4 dB over the previous model.

Excellent Ergonomics

Wide seats with air suspension and heat/cooling options, include a reclining back, upper and lower slide adjustments, and height and tilt angle adjustments to meet your needs for maximum comfort.

The fully automatic climate control system keeps operators comfortable and productive all day long in either hot or cold weather.

Storage spaces are located in the front, rear, and side consoles of the cab. A drink holder accommodates a large mug, and a shelf behind the seat stores large lunch or toolboxes.

Power supply sockets are available for charging your electronic devices like an MP3 player, a cell phone, or even a tablet.

Controls Just for You

The right and left joystick consoles can be adjusted to improve your comfort and productivity during the course of a day.

The right joystick features a button that will reduce engine speed when you are not working to help save fuel. Touch it once and speed reduces; touch it again and speed increases for normal operation.



Easy to Navigate Monitor

The new LCD monitor is easy to see and navigate. Not only can it memorize up to 10 different work tools, it's also programmable in up to 44 languages to meet today's diverse workforce. The monitor clearly displays critical information you need to operate efficiently and effectively. Plus it projects the image from the rearview camera to help you see what's going on around you so you can stay safely focused on the job at hand.

Durable Structures

Made to work in your tough, heavy-duty applications



Stable Undercarriage

Long variable gauge undercarriage contributes significantly to its outstanding stability and durability, and it adjusts to reduce shipping width.

Track shoes, links, rollers, idlers, and final drives are all built with high-tensile strength steel for long-term durability.

Cat GLT4 track link protects moving parts by keeping water, debris, and dust out and grease sealed in, which delivers longer wear life and reduced noise when traveling.

Cat Positive Pin Retention 2 (PPR2) prevents looseness of the track pin in the track link, reduces stress concentrations, and eliminates pin walking for increased service life.



Robust Frames

The 374F L is a robust, well-built machine designed to give you a very long service life. The upper frame has mountings made specifically to support the heavy-duty cab. It's also reinforced around areas that take on a lot of stress like the boom foot, skirt, and counterweight removal system.

Great Weight

An 11 mt (24,250 lb) counterweight – with or without removal device – is available to balance your work needs. Built with thick steel plates and reinforced fabrications to make it less susceptible to damage, the weight has a curved surface that matches the machine's sleek, smooth appearance along with an integrated housing to help protect the rearview camera.



Durable Linkages

Options to take on your far-reaching or up-close tasks

Booms and Sticks for Any Job

The 374F is offered with a range of booms and sticks. Each is built with internal baffle plates and is stress relieved for added durability, and each undergoes ultrasound inspection to ensure quality and reliability. Large box-section structures with thick, multi-plate fabrications, castings, and forgings are used in high-stress areas such as the boom nose, boom foot, boom cylinder, and stick foot to improve durability. Also, the boom nose pin retention method is a captured flag design for enhanced durability.

The Reach boom and sticks offer you excellent all-around versatility for general excavation work like multipurpose digging and loading.

The Mass boom and sticks offer you enhanced performance in heavy-duty material like rock. They provide higher digging forces due to special boom and stick geometry, and bucket linkage and cylinders are built for greater durability.

Pins

All front linkage pins have thick chrome plating, giving them high wear resistance. Each pin diameter is made to distribute the shear and bending loads associated with the stick and to help ensure long pin, boom and stick life.

Talk to your Cat dealer to pick the best front linkage for your applications.

Versatile

Do more jobs with one machine





Get the Most from One Machine

The Cat combination of machine and tool provides a total solution for just about any application. Work tools can be mounted either directly to the machine or to a quick coupler, making it fast and easy to release one work tool and pick up another.

Change Jobs Quickly

Cat quick coupler brings the ability to quickly change attachments and switch from job to job. The Cat coupler is the secure way to decrease downtime and increase job site flexibility and overall productivity.

Available tool control remembers pressures and flows for up to 10 tools. Simply toggle through the monitor, select the tool, and go to work for maximum efficiency.

Dig, Rip and Load

A wide range of buckets dig everything from basic top soil to extreme, harsh material like ore and high quartzite granite. Rip through rock as an alternative to blasting in quarries. High-capacity buckets load trucks in a minimum number of passes for maximum productivity.

Break, Demolish and Scrap

A hydraulic hammer ably equips your machine for breaking rock in quarries. It will also make taking down bridge pillars and heavily reinforced concrete on road demolition jobs no problem.

Multi-processor and pulverizer attachments make your machine ideal for demolition jobs and processing the resulting debris.

Shears with 360° rotation mount to the machine for processing scrap steel and metal.

Move and Handle Material

When your job requires steady material handling and loading of heavy construction debris, a contractor's grapple is a good solution.

Set Up Your Machine for Profitability

Your Cat dealer can install hydraulic kits to properly operate all Cat Work Tool attachments, maximizing the machine's uptime and your profit. All Cat Work Tool attachments are supported by the same Cat dealer network as your Cat machine.

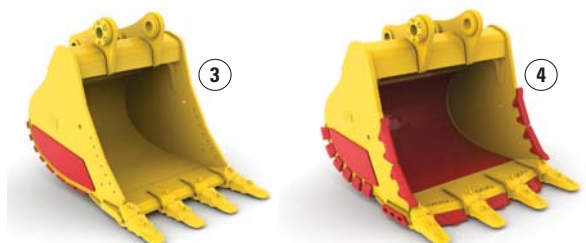
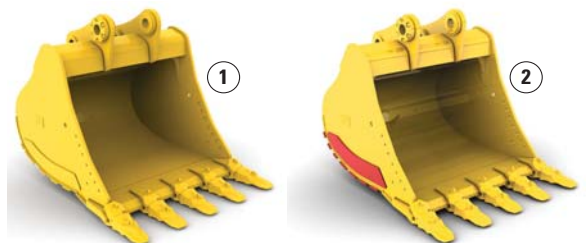

1) General Duty (GD) 2) Heavy Duty (HD)
3) Severe Duty (SD) 4) Extreme Duty (XD)

Cat Connect Technologies

Monitor, manage, and enhance job site operations

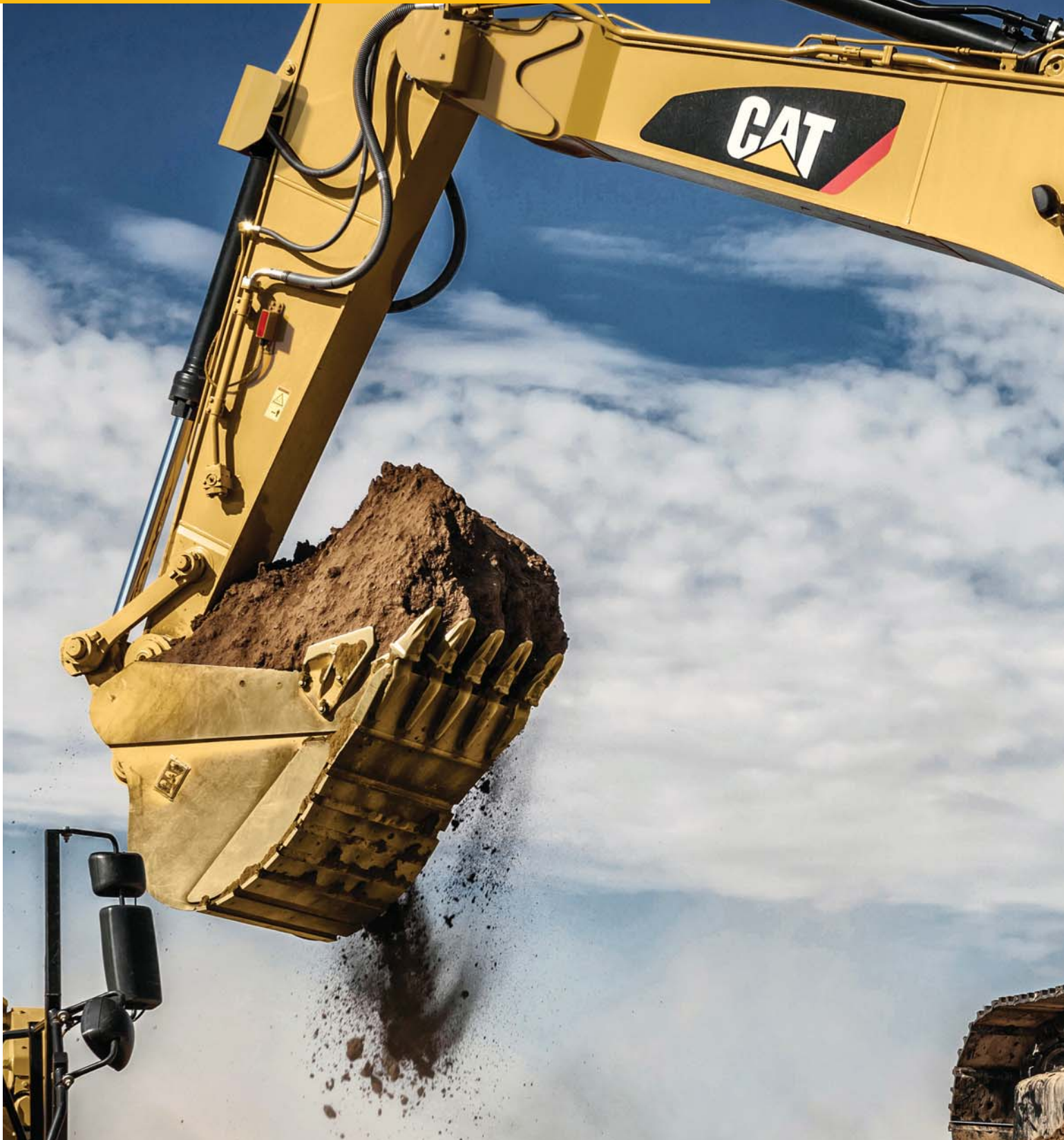

Cat Connect makes smart use of technology and services to improve your job site efficiency. Using the data from technology-equipped machines, you'll get more information and insight into your equipment and operations than ever before.

Cat Connect technologies offer improvements in these key areas:



Equipment Management – increase uptime and reduce operating costs.



Productivity – monitor production and manage job site efficiency.



Safety – enhance job site awareness to keep your people and equipment safe.



LINK Technologies

LINK technologies, like Product Link™, are deeply integrated into your machine and wirelessly communicates key information, including location, hours, fuel usage, idle time and event codes.

Product Link™/VisionLink®

Easy access to Product Link data via the online VisionLink user interface can help you see how your machine or fleet is performing. You can use this information to make timely, fact based decisions that can boost job site efficiency and productivity, and lower costs.

PAYLOAD Technologies

Payload technologies accurately measure material being loaded or hauled. Payload data is shared with operators in real-time to improve productivity, reduce overloading, and record progress.

Cat Production Measurement

Cat Production Measurement brings payload weighing to the cab, enabling operators to weigh loads “on the go.” Loads are weighed as the boom swings with no interruptions in the loading cycle, improving loading speed and efficiency. Operators can view load weights on the integrated display and know precisely how much material is in the bucket and when trucks are filled to target payload. Instant feedback gives operators the confidence to work more effectively, maximizing the potential of the entire fleet. Site managers can wirelessly access data via the VisionLink® web portal to measure production and monitor efficiency.





Reliable and Productive

Power to move your material with speed and precision

Hydraulic Horsepower, a Cat Advantage

Hydraulic horsepower is the actual machine power available to do work through implements and work tools. It's much more than just the engine power under the hood – it's a core strength that differentiates Cat machines from other brands. In fact, pump and other system components work to put more power to the ground, in a highly controlled, user-friendly way. This means you will move more material in less time and keep more money in your pocket at the end of the day.

Control Like No Other

The new Cat Adaptive Control System (ACS) valve optimizes performance by intelligently managing restrictions and flows to control machine motion, which means your operators will have the power and precision they need and expect. It opens slowly when your range of joystick lever movement is small and opens rapidly when movement is high. It smartly puts flow exactly where you need it when you need it, which leads to smoother operation, greater efficiency, and lower fuel consumption.

Auxiliary Hydraulics for Added Versatility

Auxiliary hydraulics give you greater tool versatility so you can take on more work with just one machine, and there are several options from which you can choose. A quick coupler circuit, for example, allows you to switch from one tool to another in a matter of minutes.



Safe Work Environment

Features to help protect you day in and day out



Great Views

Ample glass gives you excellent visibility out front and to the side. The rearview and side-view cameras greatly enhance visibility behind and on the side of the machine to help the operator work more productively. A panoramic rearview is automatically displayed on the new multi-function monitor during reverse travel. As an option, a second display can be added, providing a dedicated full-time rearview of the job site.

Halogen lights provide plenty of illumination. Cab and boom lights can be programmed to stay on for up to 90 seconds after the engine has been turned off to help you safely exit the machine. Optional High Intensity Discharge (HID) lights are available for enhanced night-time visibility.

Secure Contact Points

Multiple large steps as well as hand and guard rails will get you into the cab as well as a leg up to the catwalks and compartments. Extended hand and guard rails allow you to safely climb to the upper deck. Anti-skid plates on the catwalks, the surface of the upper structure, and the top of the storage box area reduce your slipping hazards in all types of weather conditions. They can be removed for cleaning.



Serviceable

Designed to make your maintenance quick and easy

Convenient Access Built In

You can reach routine maintenance items like greasing points and a concentrated remote greasing block on boom foot from ground level.

Compartments feature wide service doors designed to help prevent debris entry, and they also securely latch in place to help make your service work simpler.

Machine's slip-resistant 500 mm (19.7 in) wide catwalks stretch the length of the machine to provide safe access to major and grouped service points, such as fuel and oil filters, and fluid taps.

Quick and Convenient Fluids Service

S-O-SSM Oil sample and pressure ports provide easy checking of machine condition and are standard on every machine.

You can ensure fast, easy, and secure changing of engine and hydraulic oil with the QuickEvacTM option.

The fuel tank's drain cock makes it easy and simple for you to remove water and sediment during routine maintenance. Plus an integrated fuel level indicator pops up to help you reduce the possibility of fuel tank overfilling. An optional fast fill port accessible from ground level can make refueling even easier and faster.

An electric refueling pump allows you to refuel from other sources like a barrel or fuel reservoir when a fuel truck or regular fuel pump isn't on site. The pump automatically shuts off when the fuel tank is full.

An electric lubricator system is an available time-saving attachment. The lubricator has a grease container, greasing pump, and a hose with nozzle to help you reach all the greasing points.

A Smart Cooling Design

The 374F L features a new side-by-side cooling system with easy-to-clean cores and a new variable-speed fan that reverses to blow out unwanted debris that may accumulate during your work day.

A Fresh Idea

Selecting ventilation inside the cab allows outside air to enter through a fresh air filter. The filter is conveniently located on the side of the cab to make it easy to reach and replace, and it is protected by a lockable door that can be opened with the engine key.

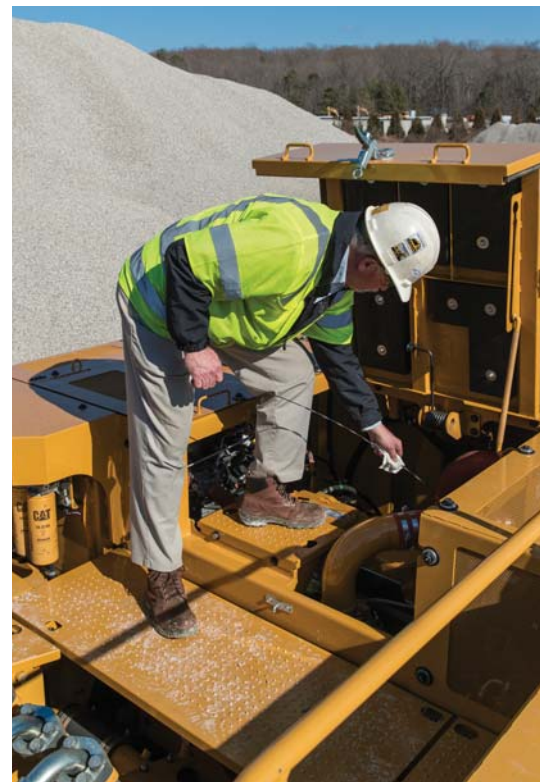

Complete Customer Care

Unmatched support makes the difference

Worldwide Parts Availability

Cat dealers utilize a worldwide parts network to maximize your machines' uptime. Plus they can help you save money with Cat remanufactured components.

Financial Options Just for You

Consider financing options and day-to-day operating costs. Look at dealer services that can be included in the machine's cost to yield lower owning and operating costs over time.

What's Best for You Today...and Tomorrow

Repair, rebuild, or replace? Your Cat dealer can help you evaluate the cost involved so you can make the best choice for your business.

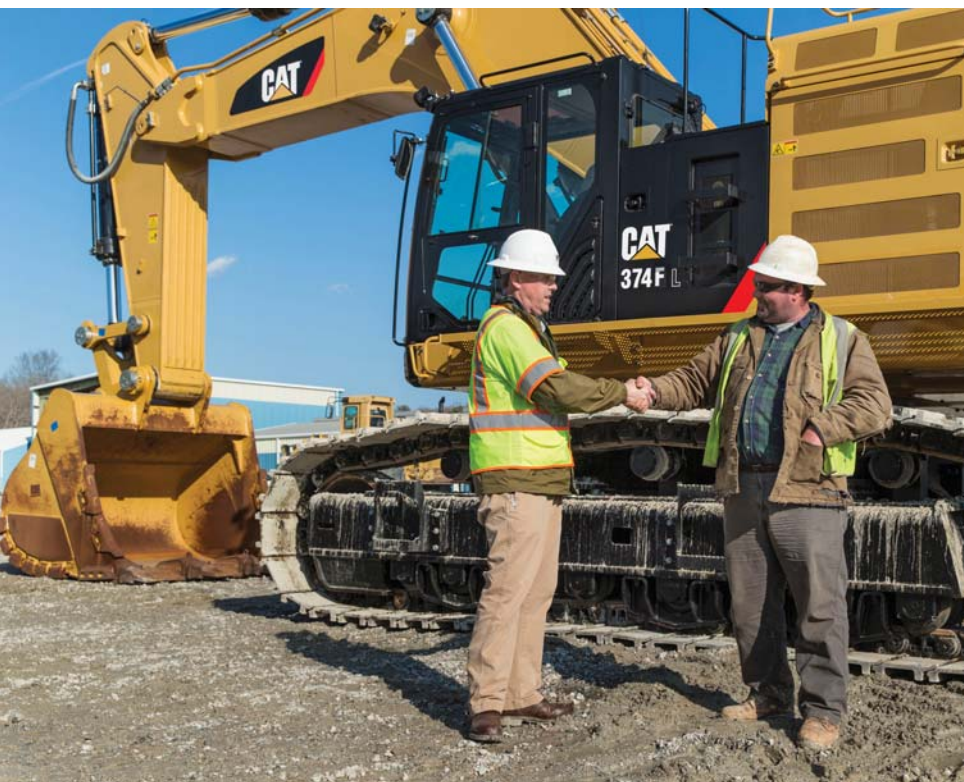

Sustainable Generations ahead in every way

The 374F L is designed to compliment your business plan, reduce emissions and minimize the consumption of natural resources.

- The C15 ACERT engine meets Tier 2, Stage II, Japan 2001 (Tier 2) equivalent or Tier 3, Stage IIIA, Japan 2006 (Tier 3) equivalent, China Nonroad Stage III emission standards.
- The 374F L consumes up to 28% less fuel than its predecessor 374D L.
- The machine has the flexibility of running on biodiesel.
- An overfill indicator rises when the tank is full to help the operator avoid spilling.
- Quick fill ports with connectors ensure fast, easy, and secure changing of hydraulic oil.
- Major components are rebuildable, eliminating waste and saving money by giving the machine and/or major components a second life – and even a third life.
- Link technologies enable you to collect and analyze equipment and job site data so you can maximize productivity and reduce costs.
- The 374F L is an efficient, productive machine that's designed to conserve our natural resources for generations ahead.

374F L Hydraulic Excavator Specifications

Engine

| | | |
|----------------------------|---------------|---------------------|
| Engine Model | Cat C15 ACERT | |
| Power – SAE J1995 | 367 kW | 492 hp |
| Power – ISO 14396 | 362 kW | 485 hp |
| Power – ISO 9249/SAE J1349 | 352 kW | 472 hp |
| Bore | 137 mm | 5.4 in |
| Stroke | 171 mm | 6.7 in |
| Displacement | 15.2 L | 928 in ³ |

- No engine power derating required below 2300 m (7,500 ft) altitude.
- Rating at 1,600 rpm (Implement).

Drive

| | | |
|----------------------|----------|-------------|
| Gradeability | 40° | |
| Maximum Travel Speed | 4.1 km/h | 2.6 mph |
| Maximum Drawbar Pull | 492 kN | 110,500 lbf |

Track

| | |
|-------------------------------------|--------|
| Track Options – Double Grouser | 900 mm |
| | 750 mm |
| | 650 mm |
| Number of Shoes Each Side | 47 |
| Number of Track Rollers Each Side | 8 |
| Number of Carrier Rollers Each Side | 3 |

Swing

| | | |
|----------------------|----------|----------------|
| Swing Speed | 6.5 rpm | |
| Swing Torque | 215 kN·m | 158,576 lbf·ft |
| Maximum Swing Torque | 313 kN·m | 230,856 lbf·ft |

Service Refill Capacities

| | | |
|-----------------------------------|-------|---------|
| Fuel Tank Capacity | 935 L | 247 gal |
| Cooling System | 74 L | 20 gal |
| Engine Oil | 60 L | 16 gal |
| Swing Drive (each) | 12 L | 3.2 gal |
| Final Drive (each) | 22 L | 5.8 gal |
| Hydraulic System (including tank) | 729 L | 193 gal |
| Hydraulic Tank | 612 L | 162 gal |

Sound Performance

| | |
|-------------------------------|-----------|
| Exterior – ISO 6395* | 108 dB(A) |
| Interior – SAE J1166/ISO 6396 | 72 dB(A) |

- Hearing protection may be needed when operating with an open operator station and cab (when not properly maintained or doors/windows open) for extended periods or in a noisy environment.
 - When properly installed and maintained, the cab offered by Caterpillar, when tested with doors and windows closed according to ANSI/SAE J1166 OCT98, meets OSHA and MSHA requirements for operator sound exposure limits in effect at time of manufacture.
- *As per European Union Directive 2000/14/EC as amended by 2005/88/EC.

Hydraulic System

| | | |
|-------------------------|-----------|--------------|
| Maximum Flow (total) | | |
| Main System – Implement | 896 L/min | 237 gal/min |
| Main System – Travel | 952 L/min | 251 gal/min |
| Pilot System | 63 L/min | 16.6 gal/min |

| | | |
|-------------------------|------------|-----------|
| Maximum Pressure | | |
| Main System – Equipment | 37 000 kPa | 5,366 psi |
| Main System – Travel | 35 000 kPa | 5,076 psi |
| Main System – Swing | 29 400 kPa | 4264 psi |
| Pilot System | 4400 kPa | 638 psi |

| | | |
|---------------|---------|---------|
| Boom Cylinder | | |
| Bore | 190 mm | 7.5 in |
| Stroke | 1792 mm | 70.6 in |

| | | |
|----------------|---------|---------|
| Stick Cylinder | | |
| Bore | 210 mm | 8.3 in |
| Stroke | 2118 mm | 83.4 in |

| | | |
|------------------------------|---------|--------|
| VB2 – Family Bucket Cylinder | | |
| Bore | 190 mm | 7.5 in |
| Stroke | 1433 mm | 56.4 |

| | | |
|------------------------------|---------|---------|
| WB2 – Family Bucket Cylinder | | |
| Bore | 200 mm | 7.9 in |
| Stroke | 1457 mm | 57.4 in |

Standards

| | |
|----------|------------------------------|
| Brakes | SAE J1026/APR90 |
| Cab/FOGS | SAE J1356/FEB88 ISO 10262 |
| DEF | ISO 22241 |

374F L Hydraulic Excavator Specifications

Dimensions

All dimensions are approximate.

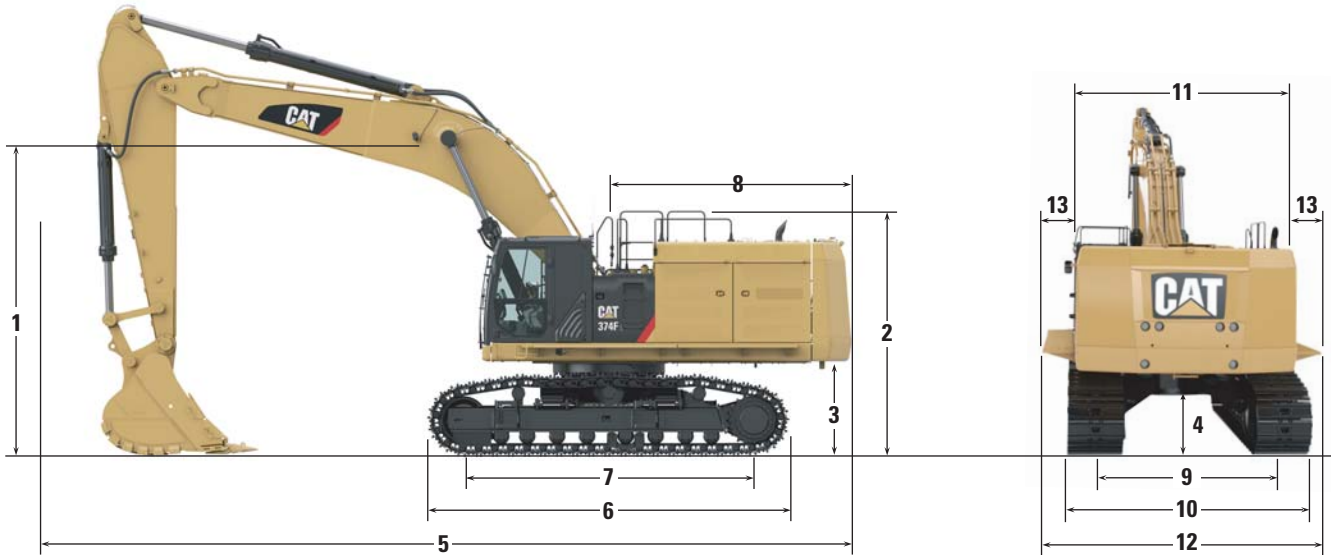

| Boom Options | Reach Boom 7.8 m (25'7") | | | Mass Boom 7.0 m (23'0") | |
|--|--|--|--|---|---|
| Stick Options | R4.67 m (15'4") | R3.60 m (11'10") | R2.84 m (9'4") | M3.0 m (9'10") | M2.57 m (8'5") |
| 1 Height – with boom/stick installed | 4990 mm (16'4") | 4520 mm (14'10") | 4300 mm (14'1") | 4720 mm (15'6") | 4630 mm (15'2") |
| 2 Guardrail Height | 3970 mm (13'0") | 3970 mm (13'0") | 3970 mm (13'0") | 3970 mm (13'0") | 3970 mm (13'0") |
| 3 Counterweight Clearance | 1540 mm (5'1") | 1540 mm (5'1") | 1540 mm (5'1") | 1540 mm (5'1") | 1540 mm (5'1") |
| 4 Ground Clearance | 840 mm (2'9") | 840 mm (2'9") | 840 mm (2'9") | 840 mm (2'9") | 840 mm (2'9") |
| 5 Length – with boom/stick installed | 13 230 mm (43'5") | 13 330 mm (43'9") | 13 430 mm (44'1") | 12 620 mm (41'5") | 12 660 mm (41'6") |
| 6 Track Length | 5870 mm (19'3") | 5870 mm (19'3") | 5870 mm (19'3") | 5870 mm (19'3") | 5870 mm (19'3") |
| 7 Length to Center of Rollers | 4705 mm (15'5") | 4705 mm (15'5") | 4705 mm (15'5") | 4705 mm (15'5") | 4705 mm (15'5") |
| 8 Tail Swing Radius | 4015 mm (13'2") | 4015 mm (13'2") | 4015 mm (13'2") | 4015 mm (13'2") | 4015 mm (13'2") |
| 9 Track Gauge – retracted | 2750 mm (9'0") | 2750 mm (9'0") | 2750 mm (9'0") | 2750 mm (9'0") | 2750 mm (9'0") |
| Track Gauge – extended | 3410 mm (11'2") | 3410 mm (11'2") | 3410 mm (11'2") | 3410 mm (11'2") | 3410 mm (11'2") |
| 10 Undercarriage Width – without steps | | | | | |
| 650 mm (26 in) Shoes | 4060 mm (13'4") | 4060 mm (13'4") | 4060 mm (13'4") | 4060 mm (13'4") | 4060 mm (13'4") |
| 750 mm (30 in) Shoes | 4160 mm (13'8") | 4160 mm (13'8") | 4160 mm (13'8") | 4160 mm (13'8") | 4160 mm (13'8") |
| 900 mm (36 in) Shoes | 4310 mm (14'2") | 4310 mm (14'2") | 4310 mm (14'2") | 4310 mm (14'2") | 4310 mm (14'2") |
| Undercarriage Width – including steps | | | | | |
| 650 mm (26 in) Shoes | 4340 mm (14'3") | 4340 mm (14'3") | 4340 mm (14'3") | 4340 mm (14'3") | 4340 mm (14'3") |
| 750 mm (30 in) Shoes | 4340 mm (14'3") | 4340 mm (14'3") | 4340 mm (14'3") | 4340 mm (14'3") | 4340 mm (14'3") |
| 900 mm (36 in) Shoes | 4340 mm (14'3") | 4340 mm (14'3") | 4340 mm (14'3") | 4340 mm (14'3") | 4340 mm (14'3") |
| 11 Upperframe Width – without walkways | 3450 mm (11'4") | 3450 mm (11'4") | 3450 mm (11'4") | 3450 mm (11'4") | 3450 mm (11'4") |
| 12 Upperframe Width – with walkways | 4510 mm (15'0") | 4510 mm (15'0") | 4510 mm (15'0") | 4510 mm (15'0") | 4510 mm (15'0") |
| 13 Walkway Width (each) | 530 mm (1'9") | 530 mm (1'9") | 530 mm (1'9") | 530 mm (1'9") | 530 mm (1'9") |
| Bucket Type | GD | GD | GD | SDV | SDV |
| Bucket Capacity | 3.8 m ³ (4.97 yd ³) | 3.8 m ³ (4.97 yd ³) | 3.8 m ³ (4.97 yd ³) | 4.6 m ³ (6.0 yd ³) | 4.6 m ³ (6.0 yd ³) |
| Bucket Tip Radius | 1900 mm (6'2") | 1900 mm (6'2") | 1900 mm (6'2") | 2000 mm (6'7") | 2000 mm (6'7") |

Dimensions may vary depending on bucket selection.

374F L Hydraulic Excavator Specifications

Working Ranges

All dimensions are approximate.

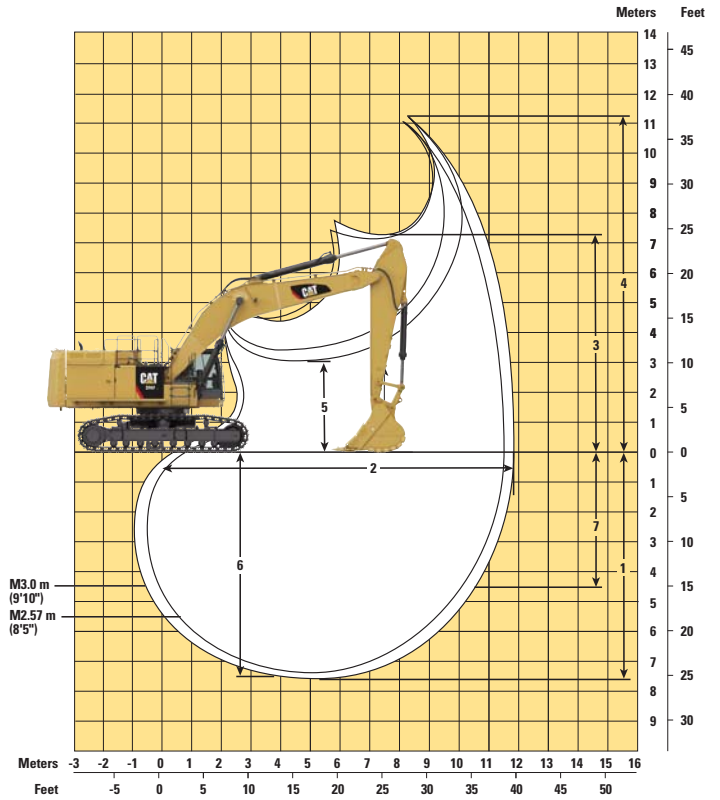
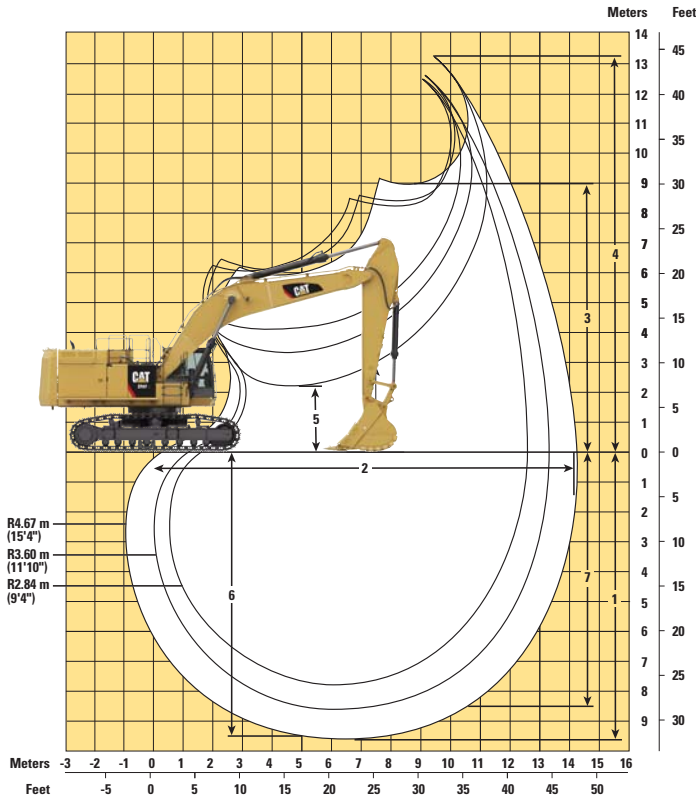

Boom Options

Reach Boom 7.8 m (25'7")

Mass Boom 7.0 m (23'0")

Stick Options

| | R4.67 m (15'4") | R3.60 m (11'10") | R2.84 m (9'4") | M3.0 m (9'10") | M2.57 m (8'5") |
|---|--|--|--|---|---|
| 1 Maximum Digging Depth | 9650 mm (31'8") | 8580 mm (28'1") | 7820 mm (25'7") | 7640 mm (25'0") | 7220 mm (23'8") |
| 2 Maximum Reach at Ground Line | 14 230 mm (46'8") | 13 170 mm (43'2") | 12 530 mm (41'1") | 11 850 mm (38'11") | 11 450 mm (37'6") |
| 3 Maximum Loading Height | 9000 mm (29'6") | 8410 mm (27'7") | 8250 mm (27'0") | 7240 mm (23'9") | 7080 mm (23'2") |
| 4 Maximum Cutting Height | 13 210 mm (43'4") | 12 560 mm (41'2") | 12 450 mm (40'10") | 11 180 mm (36'8") | 11 010 mm (36'1") |
| 5 Minimum Loading Height | 2230 mm (7'4") | 3300 mm (10'10") | 4060 mm (13'4") | 3070 mm (10'0") | 3490 mm (11'5") |
| 6 Maximum Depth Cut for 2240 mm (8 ft) Level Bottom | 9550 mm (31'4") | 8460 mm (27'9") | 7680 mm (25'2") | 7500 mm (24'7") | 7060 mm (23'1") |
| 7 Maximum Vertical Wall Digging Depth | 8530 mm (28'0") | 7140 mm (23'5") | 6660 mm (21'10") | 4510 mm (14'9") | 4140 mm (13'7") |
| Bucket Digging Force (SAE) | 314 kN (70,700 lbf) | 314 kN (70,500 lbf) | 312 kN (70,100 lbf) | 362 kN (81,400 lbf) | 362 kN (81,300 lbf) |
| Bucket Digging Force (ISO) | 359 kN (80,700 lbf) | 358 kN (80,500 lbf) | 356 kN (80,100 lbf) | 412 kN (92,600 lbf) | 411 kN (92,500 lbf) |
| Stick Digging Force (SAE) | 240 kN (54,000 lbf) | 285 kN (64,000 lbf) | 317 kN (71,200 lbf) | 314 kN (70,500 lbf) | 341 kN (76,800 lbf) |
| Stick Digging Force (ISO) | 248 kN (55,600 lbf) | 295 kN (66,400 lbf) | 330 kN (74,200 lbf) | 323 kN (72,700 lbf) | 353 kN (79,400 lbf) |
| Bucket Type | GD | GD | GD | SDV | SDV |
| Bucket Capacity | 3.8 m ³ (4.97 yd ³) | 3.8 m ³ (4.97 yd ³) | 3.8 m ³ (4.97 yd ³) | 4.6 m ³ (6.0 yd ³) | 4.6 m ³ (6.0 yd ³) |
| Bucket Tip Radius | 1900 mm (6'2") | 1900 mm (6'2") | 1900 mm (6'2") | 2000 mm (6'7") | 2000 mm (6'7") |

Dimensions may vary depending on bucket selection.

374F L Hydraulic Excavator Specifications

Operating Weights and Ground Pressures

| Boom | Stick | Bucket | 900 mm (35 in) Double Grouser Shoes | | | | 750 mm (30 in) Double Grouser Shoes | | | | 650 mm (26 in) Double Grouser Shoes | | | |
|-------------|----------------|---|--|---------|-----------------|------|--|---------|-----------------|------|--|---------|-----------------|------|
| | | | Weight | | Ground Pressure | | Weight | | Ground Pressure | | Weight | | Ground Pressure | |
| | | | kg | lb | kPa | psi | kg | lb | kPa | psi | kg | lb | kPa | psi |
| 7.8 m 25'7" | R4.67 m 15'4" | 3.8 m ³ 4.97 yd ³ | 73 200 | 161,400 | 78.0 | 11.3 | 72 190 | 159,100 | 92.3 | 13.4 | 71 515 | 157,700 | 105.5 | 15.3 |
| 7.8 m 25'7" | R3.60 m 11'10" | 3.8 m ³ 4.97 yd ³ | 72 850 | 160,600 | 77.6 | 11.3 | 71 835 | 158,400 | 91.8 | 13.3 | 71 160 | 156,900 | 105.0 | 15.2 |
| 7.8 m 25'7" | R2.84 m 9'4" | 3.8 m ³ 4.97 yd ³ | 72 665 | 160,200 | 77.4 | 11.2 | 71 650 | 158,000 | 91.6 | 13.3 | 70 975 | 156,500 | 104.7 | 15.2 |
| 7.0 m 23'0" | M3.00 m 9'10" | 4.6 m ³ 6.0 yd ³ | 75 170 | 165,700 | 80.1 | 11.6 | 74 155 | 163,500 | 94.8 | 13.7 | 73 480 | 162,000 | 108.4 | 15.7 |
| 7.0 m 23'0" | M2.57 m 8'5" | 4.6 m ³ 6.0 yd ³ | 74 960 | 165,300 | 79.9 | 11.6 | 73 945 | 163,000 | 94.5 | 13.7 | 73 270 | 161,500 | 108.1 | 15.7 |

Major Components Weights

| | kg | lb |
|---|--------|---------|
| Base Machine (with counterweight, without front linkage, without bucket)* | | |
| 650 mm (26 in) Tracks | 55 435 | 122,213 |
| 750 mm (30 in) Tracks | 56 110 | 123,701 |
| 900 mm (36 in) Tracks | 57 123 | 125,935 |
| Two Boom Cylinders | 1375 | 3,029 |
| Counterweight | | |
| Removal Type | 10 300 | 22,708 |
| Non-removal Type | 11 000 | 24,251 |
| Boom (includes lines, pins, stick cylinder) | | |
| Reach Boom – 7.8 m (25'7") | 6720 | 14,808 |
| Mass Boom – 7.0 m (23'0") | 7040 | 15,514 |
| Stick (includes lines, pins, bucket cylinder, linkage) | | |
| R4.67 m (15'4") | 4025 | 8,874 |
| R3.60 m (11'10") | 3675 | 8,100 |
| R2.84 m (9'4") | 3487 | 7,688 |
| M3.0 m (9'10") | 4228 | 9,321 |
| M2.57 m (8'5") | 4020 | 8,860 |
| Bucket | | |
| 3.8 m ³ (4.97 yd ³) GD | 3670 | 8,091 |
| 4.6 m ³ (6.0 yd ³) SDV | 4050 | 8,929 |

*Base machine includes 75 kg (165 lb) operator weight and 90% fuel weight, and undercarriage with center guard.

374F L Hydraulic Excavator Specifications

Reach Boom Lift Capacities – Counterweight: 11 mt (24,250 lb) – without Bucket

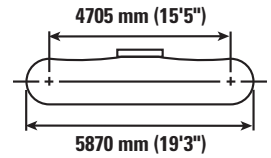
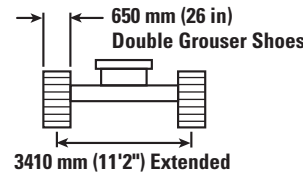
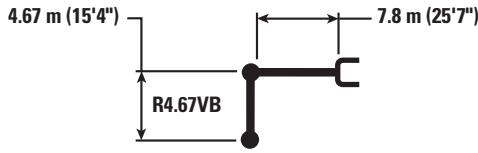

| Reach | 1.5 m/5.0 ft | | 3.0 m/10.0 ft | | 4.5 m/15.0 ft | | 6.0 m/20.0 ft | | 7.5 m/25.0 ft | | 9.0 m/30.0 ft | | 10.5 m/35.0 ft | | 12.0 m/40.0 ft | | mm in | | | | |
|---------------------|--------------|----------|---------------|----------|---------------|----------|---------------|----------|---------------|----------|---------------|----------|----------------|----------|----------------|----------|----------|----------|---------|--------|--------|
| | kg lb | kg lb | kg lb | kg lb | kg lb | kg lb | kg lb | kg lb | kg lb | kg lb | kg lb | kg lb | kg lb | kg lb | kg lb | kg lb | kg lb | kg lb | | | |
| 10.5 m 35.0 ft | | | | | | | | | | | | *12 450 | *12 450 | | | | | *11 500 | *11 500 | 9200 | |
| 9.0 m 30.0 ft | | | | | | | | | | | | *13 350 | *13 350 | | | | | *10 850 | *10 850 | 10 330 | |
| 7.5 m 25.0 ft | | | | | | | | | | | | *29,300 | *29,300 | | | | | *23,950 | *23,950 | 410 | |
| 6.0 m 20.0 ft | | | | | | | | | | | | *13 650 | *13 650 | *13 150 | 11 550 | | | *10 550 | 10 300 | 11 140 | |
| 4.5 m 15.0 ft | | | | | *28 300 | *28 300 | *21 350 | *21 350 | *17 700 | *17 700 | *15 500 | 14 100 | *14 000 | 11 050 | *11 050 | 8800 | | *10 500 | 9350 | 11 700 | |
| 3.0 m 10.0 ft | | | | | | | *24 700 | *24 700 | *19 600 | 17 750 | *16 600 | 13 550 | *14 650 | 10 700 | 11 850 | 8600 | | *11 000 | 8400 | 12 200 | |
| 1.5 m 5.0 ft | | | | | | | *53,250 | *53,250 | *42,450 | 38,300 | *36,050 | 29,150 | *31,550 | 22,950 | *24,200 | 18,450 | | *24,200 | 18,450 | 480 | |
| 0 m 0 ft | | | | | | | *27 200 | 23 350 | *21 200 | 16 900 | *17 600 | 13 000 | 14 300 | 10 350 | 11 700 | 8450 | | 11 450 | 8250 | 12 160 | |
| -1.5 m -5.0 ft | | | | | | | *58,800 | 50,350 | *45,900 | 36,450 | *38,150 | 28,000 | 30,800 | 22,250 | | | | 25,250 | 18,200 | 480 | |
| -3.0 m -10.0 ft | | | | | | | *18 350 | *18 350 | *28 450 | 22 450 | *22 200 | 16 300 | 17 600 | 12 550 | 14 050 | 10 100 | | 11 650 | 8400 | 11 930 | |
| -4.5 m -15.0 ft | | | | | | | *42,350 | *42,350 | *61,550 | 48,350 | *48,000 | 35,050 | 37,900 | 27,050 | 30,200 | 21,700 | | 25,700 | 18,450 | 470 | |
| -6.0 m -20.0 ft | | | | | | | *13 300 | *13 300 | *24 100 | *24 100 | *28 400 | 22 050 | *22 350 | 15 900 | 17 350 | 12 300 | 13 900 | 9950 | 12 250 | 8800 | 11 510 |
| -7.5 m -25.0 ft | | | | | | | *29,950 | *29,950 | *55,100 | *55,100 | *61,500 | 47,400 | *48,400 | 34,250 | 37,300 | 26,500 | 29,900 | 21,400 | 26,950 | 19,350 | 460 |
| -9.0 m -30.0 ft | *16 300 | *16 300 | *20 900 | *20 900 | *32 600 | *32 600 | *27 150 | 21 950 | *21 600 | 15 800 | 17 250 | 12 200 | 13 900 | 9950 | | | 13 300 | 9550 | 10 850 | | |
| -10.5 m -35.0 ft | *36,500 | *36,500 | *47,150 | *47,150 | *74,550 | *74,550 | *58,750 | 47,200 | *46,750 | 34,000 | 37,100 | 26,350 | 29,950 | 21,450 | | | 29,400 | 21,100 | 430 | | |
| -12.0 m -40.0 ft | | | | | | | *30 100 | *30 100 | *31 250 | *31 250 | *24 600 | 22 150 | *19 750 | 15 900 | *15 800 | 12 350 | | *13 250 | 10 900 | 9920 | |
| -13.5 m -45.0 ft | | | | | | | *68,150 | *68,150 | *67,550 | *67,550 | *53,100 | 47,650 | *42,450 | 34,250 | *33,650 | 26,650 | | *29,100 | 24,250 | 390 | |
| -15.0 m -50.0 ft | | | | | | | *32 000 | *32 000 | *25 300 | *25 300 | *20 300 | *20 300 | *16 000 | *16 000 | | | | *12 500 | *12 500 | 8640 | |
| -16.5 m -55.0 ft | | | | | | | *68,400 | *68,400 | *54,200 | *54,200 | *43,300 | *43,300 | *33,750 | *33,750 | | | | *27,350 | *27,350 | 340 | |



ISO 10567



*Indicates that the load is limited by hydraulic lifting capacity rather than tipping load. The above loads are in compliance with hydraulic excavator lift capacity standard ISO 10567:2007. They do not exceed 87% of hydraulic lifting capacity or 75% of tipping load. Weight of all lifting accessories must be deducted from the above lifting capacities. Lifting capacities are based on the machine standing on a firm, uniform supporting surface. The use of a work tool attachment point to handle/lift objects, could affect the machine lift performance.

Lift capacity stays with ±5% for all available track shoes.

Always refer to the appropriate Operation and Maintenance Manual for specific product information.

374F L Hydraulic Excavator Specifications

Reach Boom Lift Capacities – Counterweight: 11 mt (24,250 lb) – without Bucket

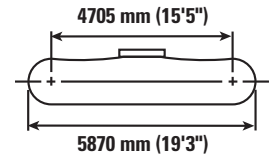
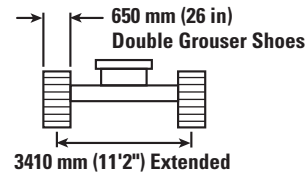

| Reach | Unit | 3.0 m/10.0 ft | | 4.5 m/15.0 ft | | 6.0 m/20.0 ft | | 7.5 m/25.0 ft | | 9.0 m/30.0 ft | | 10.5 m/35.0 ft | | mm | | in |
|----------|------|----------------|----------------|----------------|----------------|----------------|----------------|----------------|----------------|----------------|---------------|----------------|---------------|----------------|----------------|------------|
| | | kg | lb | kg | lb | kg | lb | kg | lb | kg | lb | kg | lb | kg | lb | |
| 10.5 m | kg | | | | | | | | | | | | | *15 750 | *15 750 | 7760 |
| 35.0 ft | lb | | | | | | | | | | | | | *35,100 | *35,100 | 300 |
| 9.0 m | kg | | | | | | | | | *15 300 | 14 750 | | | *14 750 | 14 550 | 9070 |
| 30.0 ft | lb | | | | | | | | | | | | | *32,600 | *32,600 | 360 |
| 7.5 m | kg | | | | | | | *16 500 | *16 500 | *15 350 | 14 700 | | | *14 300 | 12 250 | 9980 |
| 25.0 ft | lb | | | | | | | *35,950 | *35,950 | *33,550 | 31,550 | | | *31,550 | 27,300 | 390 |
| 6.0 m | kg | | | | | *20 950 | *20 950 | *17 850 | *17 850 | *15 950 | 14 350 | *14 800 | 11 100 | *14 300 | 10 900 | 10 610 |
| 20.0 ft | lb | | | | | *45,200 | *45,200 | *38,650 | *38,650 | *34,700 | 30,850 | | | *31,450 | 24,150 | 420 |
| 4.5 m | kg | | | | | *24 150 | *24 150 | *19 500 | 18 250 | *16 850 | 13 850 | 14 850 | 10 900 | 13 800 | 10 100 | 10 990 |
| 15.0 ft | lb | | | | | *51,950 | *51,950 | *42,250 | 39,400 | *36,550 | 29,850 | 31,950 | 23,400 | 30,500 | 22,300 | 440 |
| 3.0 m | kg | | | | | *27 000 | 24 000 | *21 150 | 17 400 | *17 750 | 13 350 | 14 600 | 10 600 | 13 300 | 9650 | 11 150 |
| 10.0 ft | lb | | | | | *58,200 | 51,800 | *45,750 | 37,550 | *38,500 | 28,800 | 31,400 | 22,850 | 29,300 | 21,300 | 440 |
| 1.5 m | kg | | | | | *28 650 | 22 950 | *22 300 | 16 700 | 18 000 | 12 950 | 14 350 | 10 400 | 13 200 | 9550 | 11 110 |
| 5.0 ft | lb | | | | | *61,950 | 49,450 | *48,300 | 36,050 | 38,700 | 27,900 | 30,850 | 22,350 | 29,050 | 21,050 | 440 |
| 0 m | kg | | | | | *28 850 | 22 450 | *22 750 | 16 300 | 17 650 | 12 650 | 14 150 | 10 200 | 13 500 | 9750 | 10 860 |
| 0 ft | lb | | | *36,750 | *36,750 | *62,550 | 48,300 | *49,200 | 35,100 | 38,000 | 27,250 | 30,500 | 22,000 | 29,750 | 21,500 | 430 |
| -1.5 m | kg | | | | | *26 100 | *26 100 | *27 850 | 22 300 | *22 250 | 16 100 | 17 500 | 12 500 | 14 350 | 10 350 | 10 390 |
| -5.0 ft | lb | | | | | *59,850 | *59,850 | *60,400 | 47,950 | *48,200 | 34,650 | 37,700 | 26,950 | 31,650 | 22,800 | 410 |
| -3.0 m | kg | *25 650 | *25 650 | *31 800 | *31 800 | *25 650 | 22 400 | *20 750 | 16 150 | *16 700 | 12 550 | | | *14 850 | 11 500 | 9660 |
| -10.0 ft | lb | *58,000 | *58,000 | *69,100 | *69,100 | *55,600 | 48,200 | *44,800 | 34,750 | *35,800 | 27,150 | | | *32,700 | 25,450 | 380 |
| -4.5 m | kg | *31 600 | *31 600 | *26 750 | *26 750 | *22 000 | *22 000 | *17 650 | 16 450 | | | | | *14 250 | 13 700 | 8600 |
| -15.0 ft | lb | *68,450 | *68,450 | *57,800 | *57,800 | *47,300 | *47,300 | *37,700 | 35,450 | | | | | *31,350 | 30,550 | 340 |
| -6.0 m | kg | | | | | *15 700 | *15 700 | | | | | | | *12 450 | *12 450 | 7070 |
| -20.0 ft | lb | | | | | *32,800 | *32,800 | | | | | | | *26,950 | *26,950 | 280 |



ISO 10567



* Indicates that the load is limited by hydraulic lifting capacity rather than tipping load. The above loads are in compliance with hydraulic excavator lift capacity standard ISO 10567:2007. They do not exceed 87% of hydraulic lifting capacity or 75% of tipping load. Weight of all lifting accessories must be deducted from the above lifting capacities. Lifting capacities are based on the machine standing on a firm, uniform supporting surface. The use of a work tool attachment point to handle/lift objects, could affect the machine lift performance.

Lift capacity stays with ±5% for all available track shoes.

Always refer to the appropriate Operation and Maintenance Manual for specific product information.

374F L Hydraulic Excavator Specifications

Reach Boom Lift Capacities – Counterweight: 11 mt (24,250 lb) – without Bucket

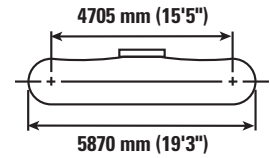
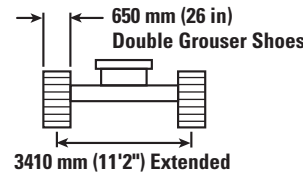
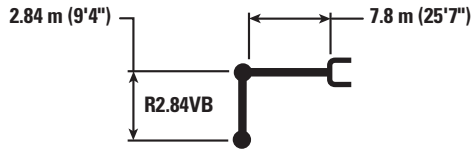

| Reach | Unit | 4.5 m/15.0 ft | | 6.0 m/20.0 ft | | 7.5 m/25.0 ft | | 9.0 m/30.0 ft | | 10.5 m/35.0 ft | | mm in | | |
|--------------------|----------|--------------------|--------------------|--------------------|--------------------|--------------------|--------------------|--------------------|------------------|------------------|----------|--------------------|--------------------|---------------|
| | | kg lb | kg lb | kg lb | kg lb | kg lb | kg lb | kg lb | kg lb | kg lb | kg lb | kg lb | kg lb | |
| 10.5 m 35.0 ft | kg lb | | | | | | | | | | | *18 700 | *18 700 | 6820 |
| 9.0 m 30.0 ft | kg lb | | | | | *17 450 *38,350 | *17 450 *38,350 | | | | | *17 200 *38,100 | 16 650 37,600 | 8280 330 |
| 7.5 m 25.0 ft | kg lb | | | | | *17 850 *38,950 | *17 850 *38,950 | *16 600 *36,450 | 14 400 30,850 | | | *16 500 *36,450 | 13 650 30,450 | 9280 370 |
| 6.0 m 20.0 ft | kg lb | *30 350 *64,750 | *30 350 *64,750 | *22 800 *49,100 | *22 800 *49,100 | *19 050 *41,350 | 18 800 40,500 | *16 950 *36,900 | 14 150 30,400 | | | *16 150 *35,650 | 12 000 26,600 | 9950 390 |
| 4.5 m 15.0 ft | kg lb | | | *25 850 *55,600 | 24 850 53,650 | *20 600 *44,550 | 17 950 38,700 | *17 650 *38,350 | 13 700 29,500 | | | 15 100 33,350 | 11 050 24,400 | 10 350 410 |
| 3.0 m 10.0 ft | kg lb | | | *28 250 *60,900 | 23 450 50,600 | *21 950 *47,550 | 17 150 37,000 | 18 350 39,450 | 13 250 28,600 | 14 550 10 600 | | 14 500 31,950 | 10 550 23,250 | 10 530 420 |
| 1.5 m 5.0 ft | kg lb | | | *29 050 *62,950 | 22 700 48,850 | *22 750 *49,300 | 16 600 35,750 | 17 950 38,650 | 12 900 27,800 | | | 14 400 31,750 | 10 450 23,000 | 10 490 420 |
| 0 m 0 ft | kg lb | | | *28 450 *61,800 | 22 400 48,250 | *22 750 *49,300 | 16 250 35,050 | 17 700 38,150 | 12 700 27,350 | | | 14 850 32,700 | 10 750 23,650 | 10 220 410 |
| -1.5 m -5.0 ft | kg lb | *24 800 *57,500 | *24 800 *57,500 | *26 800 *58,200 | 22 450 48,250 | *21 800 *47,150 | 16 200 34,900 | 17 650 38,100 | 12 650 27,300 | | | *15 800 *34,750 | 11 500 25,400 | 9710 390 |
| -3.0 m -10.0 ft | kg lb | *28 300 *61,600 | *28 300 *61,600 | *23 950 *51,900 | 22 700 48,850 | *19 600 *42,200 | 16 350 35,300 | | | | | *15 300 *33,650 | 13 050 28,900 | 8930 350 |
| -4.5 m -15.0 ft | kg lb | *22 600 *48,800 | *22 600 *48,800 | *19 350 *41,450 | *19 350 *41,450 | *15 050 *31,300 | *15 050 *31,300 | | | | | *14 000 *30,550 | *14 000 *30,550 | 7770 310 |



ISO 10567



*Indicates that the load is limited by hydraulic lifting capacity rather than tipping load. The above loads are in compliance with hydraulic excavator lift capacity standard ISO 10567:2007. They do not exceed 87% of hydraulic lifting capacity or 75% of tipping load. Weight of all lifting accessories must be deducted from the above lifting capacities. Lifting capacities are based on the machine standing on a firm, uniform supporting surface. The use of a work tool attachment point to handle/lift objects, could affect the machine lift performance.

Lift capacity stays with ±5% for all available track shoes.

Always refer to the appropriate Operation and Maintenance Manual for specific product information.

374F L Hydraulic Excavator Specifications

Mass Boom Lift Capacities – Counterweight: 11 mt (24,250 lb) – without Bucket

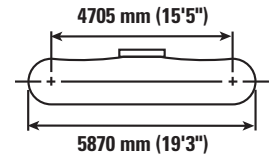
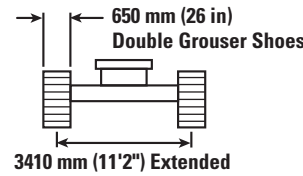
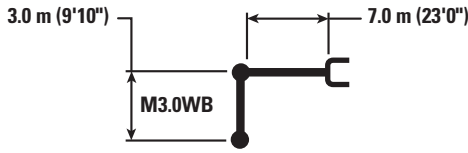

| Reach Height | 3.0 m/10.0 ft | | 4.5 m/15.0 ft | | 6.0 m/20.0 ft | | 7.5 m/25.0 ft | | 9.0 m/30.0 ft | |  | | | |
|--------------------|---------------|---------------------------|---------------------------|---------------------------|---------------------------|---------------------------|---------------------------|---------------------------|---------------------------|-------------------------|---|---------------------------|---------------------------|--------------------|
| | kg lb | kg lb | kg lb | kg lb | kg lb | kg lb | kg lb | kg lb | kg lb | kg lb | kg lb | kg lb | mm in | |
| 9.0 m 30.0 ft | | | | | | | | | | | | *14 750 *32,750 | *14 750 *32,750 | 7350 290 |
| 7.5 m 25.0 ft | | | | | | | *17 400 *38,150 | *17 400 *38,150 | | | | *13 950 *30,800 | *13 950 *30,800 | 8460 330 |
| 6.0 m 20.0 ft | | | | | *20 950 *45,300 | *20 950 *45,300 | *18 250 *39,750 | *18 250 *39,750 | *16 850 *30,400 | 13 950 29,850 | | *13 750 *30,300 | 13 450 29,850 | 9190 360 |
| 4.5 m 15.0 ft | | | *32 500 *69,550 | *32 500 *69,550 | *23 850 *51,450 | *23 850 *51,450 | *19 700 *42,700 | 18 150 39,050 | *17 350 *37,800 | 13 600 29,200 | | *14 000 *30,750 | 12 150 26,900 | 9630 380 |
| 3.0 m 10.0 ft | | | | | *26 650 *57,500 | 24 100 51,950 | *21 150 *45,850 | 17 300 37,300 | *18 000 *39,150 | 13 200 28,350 | | *14 600 *32,150 | 11 500 25,400 | 9820 390 |
| 1.5 m 5.0 ft | | | | | *28 400 *61,400 | 23 000 49,550 | *22 250 *48,200 | 16 650 35,900 | 17 900 38,500 | 12 800 27,550 | | *15 750 *34,650 | 11 350 25,050 | 9770 390 |
| 0 m 0 ft | | | *30 800 *71,400 | *30 800 *71,400 | *28 650 *62,100 | 22 450 48,350 | *22 550 *48,850 | 16 250 35,000 | 17 650 38,000 | 12 600 27,100 | | 16 400 36,100 | 11 700 25,800 | 9480 380 |
| -1.5 m -5.0 ft | kg lb | *25 350 *57,300 | *25 350 *57,300 | *35 350 *76,850 | *35 350 *76,850 | *27 500 *59,550 | 22 350 48,050 | *21 750 *47,000 | 16 100 34,700 | | | *17 300 *38,100 | 12 700 28,050 | 8930 360 |
| -3.0 m -10.0 ft | kg lb | *38 200 *83,200 | *38 200 *83,200 | *31 100 *67,400 | *31 100 *67,400 | *24 650 *53,200 | 22 550 48,550 | *19 200 *41,100 | 16 300 35,200 | | | *17 050 *37,550 | 14 850 32,900 | 8070 320 |
| -4.5 m -15.0 ft | kg lb | | | *24 150 *51,700 | *24 150 *51,700 | *18 950 *40,100 | *18 950 *40,100 | | | | | *15 800 *34,600 | *15 800 *34,600 | 6760 270 |



ISO 10567



*Indicates that the load is limited by hydraulic lifting capacity rather than tipping load. The above loads are in compliance with hydraulic excavator lift capacity standard ISO 10567:2007. They do not exceed 87% of hydraulic lifting capacity or 75% of tipping load. Weight of all lifting accessories must be deducted from the above lifting capacities. Lifting capacities are based on the machine standing on a firm, uniform supporting surface. The use of a work tool attachment point to handle/lift objects, could affect the machine lift performance.

Lift capacity stays with ±5% for all available track shoes.

Always refer to the appropriate Operation and Maintenance Manual for specific product information.

374F L Hydraulic Excavator Specifications

Mass Boom Lift Capacities – Counterweight: 11 mt (24,250 lb) – without Bucket

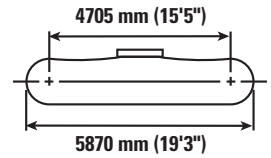
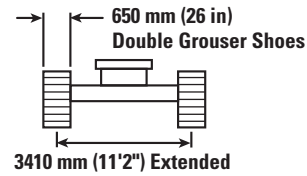
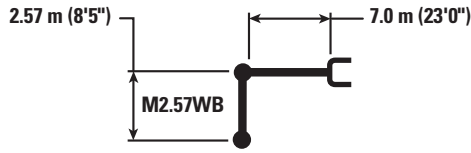

| Reach | Unit | 3.0 m/10.0 ft | | 4.5 m/15.0 ft | | 6.0 m/20.0 ft | | 7.5 m/25.0 ft | | 9.0 m/30.0 ft | | mm in | | |
|--------------------|----------|---------------|---------------------------|---------------------------|---------------------------|---------------------------|---------------------------|---------------------------|---------------------------|---------------------------|-------------------------|---------------------------|---------------------------|-------------|
| | | kg lb | kg lb | kg lb | kg lb | kg lb | kg lb | kg lb | kg lb | kg lb | kg lb | kg lb | kg lb | |
| 9.0 m 30.0 ft | kg lb | | | | | | | | | | | *17 650 *39,250 | *17 650 *39,250 | 6820 270 |
| 7.5 m 25.0 ft | kg lb | | | | | | | *18 450 *40,450 | *18 450 *40,450 | | | *16 650 *36,750 | *16 650 *36,750 | 8010 320 |
| 6.0 m 20.0 ft | kg lb | | | | | *22 050 *47,750 | *22 050 *47,750 | *19 100 *41,600 | 18 750 40,400 | | | *16 400 *36,100 | 14 450 32,100 | 8770 350 |
| 4.5 m 15.0 ft | kg lb | | | | | *24 900 *53,700 | *24 900 *53,700 | *20 400 *44,250 | 18 050 38,850 | *18 000 *39,200 | 13 550 29,100 | *16 700 *36,750 | 13 000 28,750 | 9230 370 |
| 3.0 m 10.0 ft | kg lb | | | | | *27 500 *59,350 | 23 900 51,600 | *21 750 *47,100 | 17 300 37,250 | 18 300 39,350 | 13 200 28,400 | 17 000 37,550 | 12 300 27,100 | 9430 380 |
| 1.5 m 5.0 ft | kg lb | | | | | *28 850 *62,400 | 23 000 49,500 | *22 600 *49,000 | 16 700 35,950 | 17 950 38,650 | 12 900 27,750 | 16 900 37,250 | 12 150 26,750 | 9380 370 |
| 0 m 0 ft | kg lb | | | *28 500 *66,800 | *28 500 *66,800 | *28 650 *62,150 | 22 600 48,550 | *22 650 *49,050 | 16 350 35,200 | 17 800 38,750 | 12 750 27,700 | 17 600 38,750 | 12 600 27,700 | 9080 360 |
| -1.5 m -5.0 ft | kg lb | | *58,250 | *33 950 *73,900 | *33 950 *73,900 | *27 050 *58,650 | 22 550 48,500 | *21 450 *46,350 | 16 300 35,150 | | | *18 050 *39,800 | 13 800 30,450 | 8510 340 |
| -3.0 m -10.0 ft | kg lb | | *33 600 *73,450 | *29 250 *63,450 | *29 250 *63,450 | *23 600 *50,950 | 22 900 49,250 | *18 000 | 16 650 | | | *17 600 *38,650 | 16 400 36,400 | 7590 300 |
| -4.5 m -15.0 ft | kg lb | | | *21 400 *45,650 | *21 400 *45,650 | *16 450 | *16 450 | | | | | *15 600 *33,900 | *15 600 *33,900 | 6180 240 |



ISO 10567



*Indicates that the load is limited by hydraulic lifting capacity rather than tipping load. The above loads are in compliance with hydraulic excavator lift capacity standard ISO 10567:2007. They do not exceed 87% of hydraulic lifting capacity or 75% of tipping load. Weight of all lifting accessories must be deducted from the above lifting capacities. Lifting capacities are based on the machine standing on a firm, uniform supporting surface. The use of a work tool attachment point to handle/lift objects, could affect the machine lift performance.

Lift capacity stays with ±5% for all available track shoes.

Always refer to the appropriate Operation and Maintenance Manual for specific product information.

374F L Hydraulic Excavator Specifications

Reach Boom Lift Capacities – Counterweight: 11 mt (24,250 lb) – without Bucket

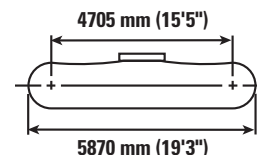
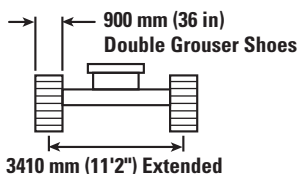
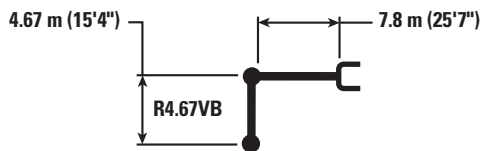

| Reach | 1.5 m/5.0 ft | | 3.0 m/10.0 ft | | 4.5 m/15.0 ft | | 6.0 m/20.0 ft | | 7.5 m/25.0 ft | | 9.0 m/30.0 ft | | 10.5 m/35.0 ft | | 12.0 m/40.0 ft | | mm | | in |
|--------------------|--------------|---------|---------------|---------|---------------|---------|---------------|---------|---------------|---------|---------------|---------|----------------|--------|----------------|------|---------|---------|--------|
| | kg | lb | kg | lb | kg | lb | kg | lb | kg | lb | kg | lb | kg | lb | kg | lb | kg | lb | |
| 10.5 m 35.0 ft | | | | | | | | | | | *12 450 | *12 450 | | | | | *11 500 | *11 500 | 9200 |
| 9.0 m 30.0 ft | | | | | | | | | | | *13 350 | *13 350 | | | | | *10 850 | *10 850 | 10 330 |
| 7.5 m 25.0 ft | | | | | | | | | | | *13 650 | *13 650 | *13 150 | 11 800 | | | *10 550 | *10 550 | 11 140 |
| 6.0 m 20.0 ft | | | | | | | | | | | *14 450 | *14 450 | *13 450 | 11 600 | | | *10 500 | 9550 | 11 700 |
| 4.5 m 15.0 ft | | | | | *28 300 | *28 300 | *21 350 | *21 350 | *17 700 | *17 700 | *15 500 | 14 450 | *14 000 | 11 300 | *11 050 | 9000 | *10 650 | 8950 | 12 050 |
| 3.0 m 10.0 ft | | | | | | | *24 700 | *24 700 | *19 600 | 18 200 | *16 600 | 13 850 | *14 650 | 10 950 | 12 200 | 8850 | *11 000 | 8600 | 12 200 |
| 1.5 m 5.0 ft | | | | | | | *27 200 | 23 950 | *21 200 | 17 300 | *17 600 | 13 300 | *14 700 | 10 600 | 12 000 | 8650 | *11 600 | 8500 | 12 160 |
| 0 m 0 ft | | | | | *18 350 | *18 350 | *28 450 | 23 050 | *22 200 | 16 700 | 18 050 | 12 900 | 14 400 | 10 350 | | | 12 000 | 8600 | 11 930 |
| -1.5 m -5.0 ft | | | *13 300 | *13 300 | *24 100 | *24 100 | *28 400 | 22 600 | *22 350 | 16 300 | 17 800 | 12 650 | 14 250 | 10 200 | | | 12 550 | 9000 | 11 510 |
| -3.0 m -10.0 ft | *16 300 | *16 300 | *20 900 | *20 900 | *32 600 | *32 600 | *27 150 | 22 500 | *21 600 | 16 200 | *17 650 | 12 550 | 14 250 | 10 200 | | | *13 450 | 9800 | 10 850 |
| -4.5 m -15.0 ft | | | *30 100 | *30 100 | *31 250 | *31 250 | *24 600 | 22 700 | *19 750 | 16 300 | *15 800 | 12 700 | | | | | *13 250 | 11 200 | 9920 |
| -6.0 m -20.0 ft | | | *32 000 | *32 000 | *25 300 | *25 300 | *20 300 | *20 300 | *16 000 | *16 000 | | | | | | | *12 500 | *12 500 | 8640 |
| | | | *68,400 | *68,400 | *54,200 | *54,200 | *43,300 | *43,300 | *33,750 | *33,750 | | | | | | | *27,350 | *27,350 | 340 |



ISO 10567



*Indicates that the load is limited by hydraulic lifting capacity rather than tipping load. The above loads are in compliance with hydraulic excavator lift capacity standard ISO 10567:2007. They do not exceed 87% of hydraulic lifting capacity or 75% of tipping load. Weight of all lifting accessories must be deducted from the above lifting capacities. Lifting capacities are based on the machine standing on a firm, uniform supporting surface. The use of a work tool attachment point to handle/lift objects, could affect the machine lift performance.

Lift capacity stays with ±5% for all available track shoes.

Always refer to the appropriate Operation and Maintenance Manual for specific product information.

374F L Hydraulic Excavator Specifications

Reach Boom Lift Capacities – Counterweight: 11 mt (24,250 lb) – without Bucket

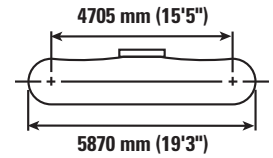
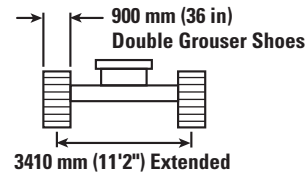

| Reach | Unit | 3.0 m/10.0 ft | | 4.5 m/15.0 ft | | 6.0 m/20.0 ft | | 7.5 m/25.0 ft | | 9.0 m/30.0 ft | | 10.5 m/35.0 ft | | mm | | in |
|----------|------|----------------|----------------|----------------|----------------|----------------|----------------|----------------|----------------|----------------|---------------|----------------|---------------|----------------|----------------|------------|
| | | kg | lb | kg | lb | kg | lb | kg | lb | kg | lb | kg | lb | kg | lb | |
| 10.5 m | kg | | | | | | | | | | | | | *15 750 | *15 750 | 7760 |
| 35.0 ft | lb | | | | | | | | | | | | | *35,100 | *35,100 | 300 |
| 9.0 m | kg | | | | | | | | | *15 300 | 15 100 | | | *14 750 | *14 750 | 9070 |
| 30.0 ft | lb | | | | | | | | | | | | | *32,600 | *32,600 | 360 |
| 7.5 m | kg | | | | | | | *16 500 | *16 500 | *15 350 | 15 000 | | | *14 300 | 12 550 | 9980 |
| 25.0 ft | lb | | | | | | | *35,950 | *35,950 | *33,550 | 32,250 | | | *31,550 | 27,950 | 390 |
| 6.0 m | kg | | | | | *20 950 | *20 950 | *17 850 | *17 850 | *15 950 | 14 650 | *14 800 | 11 350 | *14 300 | 11 150 | 10 610 |
| 20.0 ft | lb | | | | | *45,200 | *45,200 | *38,650 | *38,650 | *34,700 | 31,550 | | | *31,450 | 24,750 | 420 |
| 4.5 m | kg | | | | | *24 150 | *24 150 | *19 500 | 18 700 | *16 850 | 14 200 | *15 150 | 11 150 | 14 150 | 10 350 | 10 990 |
| 15.0 ft | lb | | | | | *51,950 | *51,950 | *42,250 | 40,300 | *36,550 | 30,550 | 32,750 | 23,950 | 31,300 | 22,850 | 440 |
| 3.0 m | kg | | | | | *27 000 | 24 550 | *21 150 | 17 800 | *17 750 | 13 700 | 14 950 | 10 900 | 13 650 | 9900 | 11 150 |
| 10.0 ft | lb | | | | | *58,200 | 53,000 | *45,750 | 38,450 | *38,500 | 29,500 | 32,150 | 23,400 | 30,050 | 21,850 | 440 |
| 1.5 m | kg | | | | | *28 650 | 23 500 | *22 300 | 17 150 | *18 450 | 13 250 | 14 700 | 10 650 | 13 550 | 9800 | 11 110 |
| 5.0 ft | lb | | | | | *61,950 | 50,650 | *48,300 | 36,950 | 39,700 | 28,600 | 31,650 | 22,900 | 29,800 | 21,600 | 440 |
| 0 m | kg | | | | | *28 850 | 23 000 | *22 750 | 16 700 | 18 100 | 12 950 | 14 550 | 10 500 | 13 850 | 10 000 | 10 860 |
| 0 ft | lb | | | *36,750 | *36,750 | *62,550 | 49,500 | *49,200 | 35,950 | 39,000 | 27,950 | 31,300 | 22,600 | 30,550 | 22,050 | 430 |
| -1.5 m | kg | | | *26 100 | *26 100 | *27 850 | 22 850 | *22 250 | 16 500 | 17 950 | 12 850 | | | 14 750 | 10 600 | 10 390 |
| -5.0 ft | lb | | | *59,850 | *59,850 | *60,400 | 49,150 | *48,200 | 35,550 | 38,700 | 27,650 | | | 32,500 | 23,400 | 410 |
| -3.0 m | kg | *25 650 | *25 650 | *31 800 | *31 800 | *25 650 | 22 950 | *20 750 | 16 550 | *16 700 | 12 900 | | | *14 850 | 11 800 | 9660 |
| -10.0 ft | lb | *58,000 | *58,000 | *69,100 | *69,100 | *55,600 | 49,400 | *44,800 | 35,650 | *35,800 | 27,850 | | | *32,700 | 26,100 | 380 |
| -4.5 m | kg | *31 600 | *31 600 | *26 750 | *26 750 | *22 000 | *22 000 | *17 650 | 16 850 | | | | | *14 250 | 14 050 | 8600 |
| -15.0 ft | lb | *68,450 | *68,450 | *57,800 | *57,800 | *47,300 | *47,300 | *37,700 | 36,350 | | | | | *31,350 | 31,300 | 340 |
| -6.0 m | kg | | | | | *15 700 | *15 700 | | | | | | | *12 450 | *12 450 | 7070 |
| -20.0 ft | lb | | | | | *32,800 | *32,800 | | | | | | | *26,950 | *26,950 | 280 |



ISO 10567



*Indicates that the load is limited by hydraulic lifting capacity rather than tipping load. The above loads are in compliance with hydraulic excavator lift capacity standard ISO 10567:2007. They do not exceed 87% of hydraulic lifting capacity or 75% of tipping load. Weight of all lifting accessories must be deducted from the above lifting capacities. Lifting capacities are based on the machine standing on a firm, uniform supporting surface. The use of a work tool attachment point to handle/lift objects, could affect the machine lift performance.

Lift capacity stays with ±5% for all available track shoes.

Always refer to the appropriate Operation and Maintenance Manual for specific product information.

374F L Hydraulic Excavator Specifications

Reach Boom Lift Capacities – Counterweight: 11 mt (24,250 lb) – without Bucket

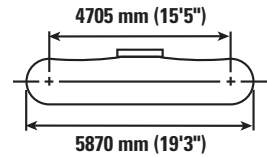
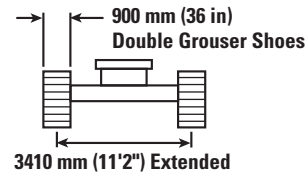
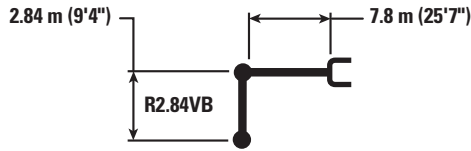

| Reach | Unit | 4.5 m/15.0 ft | | 6.0 m/20.0 ft | | 7.5 m/25.0 ft | | 9.0 m/30.0 ft | | 10.5 m/35.0 ft | | mm | | |
|----------|------|---------------|---------|---------------|---------|---------------|---------|---------------|--------|----------------|--------|---------|---------|--------|
| | | kg | lb | kg | lb | kg | lb | kg | lb | kg | lb | mm | in | |
| 10.5 m | kg | | | | | | | | | | | *18 700 | *18 700 | 6820 |
| 35.0 ft | lb | | | | | | | | | | | | | |
| 9.0 m | kg | | | | | *17 450 | *17 450 | | | | | *17 200 | 17 000 | 8280 |
| 30.0 ft | lb | | | | | *38,350 | *38,350 | | | | | *38,100 | *38,100 | 330 |
| 7.5 m | kg | | | | | *17 850 | *17 850 | *16 600 | 14 750 | | | *16 500 | 13 950 | 9280 |
| 25.0 ft | lb | | | | | *38,950 | *38,950 | *36,450 | 31,550 | | | *36,450 | 31,150 | 370 |
| 6.0 m | kg | *30 350 | *30 350 | *22 800 | *22 800 | *19 050 | *19 050 | *16 950 | 14 450 | | | *16 150 | 12 300 | 9950 |
| 20.0 ft | lb | *64,750 | *64,750 | *49,100 | *49,100 | *41,350 | *41,350 | *36,900 | 31,100 | | | *35,650 | 27,250 | 390 |
| 4.5 m | kg | | | *25 850 | 25 400 | *20 600 | 18 350 | *17 650 | 14 050 | | | 15 500 | 11 300 | 10 350 |
| 15.0 ft | lb | | | *55,600 | 54,850 | *44,550 | 39,600 | *38,350 | 30,250 | | | 34,200 | 25,000 | 410 |
| 3.0 m | kg | | | *28 250 | 24 000 | *21 950 | 17 550 | *18 350 | 13 600 | 14 900 | 10 850 | 14 850 | 10 800 | 10 530 |
| 10.0 ft | lb | | | *60,900 | 51,800 | *47,550 | 37,900 | *39,850 | 29,300 | | | 32,750 | 23,850 | 420 |
| 1.5 m | kg | | | *29 050 | 23 250 | *22 750 | 17 000 | 18 400 | 13 250 | | | 14 800 | 10 750 | 10 490 |
| 5.0 ft | lb | | | *62,950 | 50,050 | *49,300 | 36,650 | 39,600 | 28,500 | | | 32,550 | 23,600 | 420 |
| 0 m | kg | | | *28 450 | 23 000 | *22 750 | 16 700 | 18 150 | 13 000 | | | 15 250 | 11 000 | 10 220 |
| 0 ft | lb | | | *61,800 | 49,450 | *49,300 | 35,950 | 39,100 | 28,050 | | | 33,550 | 24,250 | 410 |
| -1.5 m | kg | *24 800 | *24 800 | *26 800 | 23 000 | *21 800 | 16 600 | *17 750 | 13 000 | | | *15 800 | 11 800 | 9710 |
| -5.0 ft | lb | *57,500 | *57,500 | *58,200 | 49,500 | *47,150 | 35,800 | *38,200 | 28,000 | | | *34,750 | 26,050 | 390 |
| -3.0 m | kg | *28 300 | *28 300 | *23 950 | 23 250 | *19 600 | 16 800 | | | | | *15 300 | 13 400 | 8930 |
| -10.0 ft | lb | *61,600 | *61,600 | *51,900 | 50,050 | *42,200 | 36,200 | | | | | *33,650 | 29,650 | 350 |
| -4.5 m | kg | *22 600 | *22 600 | *19 350 | *19 350 | *15 050 | *15 050 | | | | | *14 000 | *14 000 | 7770 |
| -15.0 ft | lb | *48,800 | *48,800 | *41,450 | *41,450 | *31,300 | *31,300 | | | | | *30,550 | *30,550 | 310 |



ISO 10567



*Indicates that the load is limited by hydraulic lifting capacity rather than tipping load. The above loads are in compliance with hydraulic excavator lift capacity standard ISO 10567:2007. They do not exceed 87% of hydraulic lifting capacity or 75% of tipping load. Weight of all lifting accessories must be deducted from the above lifting capacities. Lifting capacities are based on the machine standing on a firm, uniform supporting surface. The use of a work tool attachment point to handle/lift objects, could affect the machine lift performance.









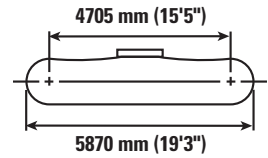
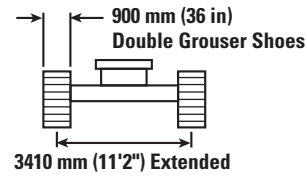
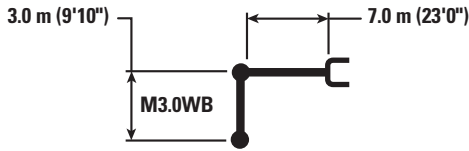



Lift capacity stays with ±5% for all available track shoes.

Always refer to the appropriate Operation and Maintenance Manual for specific product information.

374F L Hydraulic Excavator Specifications

Mass Boom Lift Capacities – Counterweight: 11 mt (24,250 lb) – without Bucket



| | | 3.0 m/10.0 ft | | 4.5 m/15.0 ft | | 6.0 m/20.0 ft | | 7.5 m/25.0 ft | | 9.0 m/30.0 ft | |  | | mm in |
|--------------------|----------|---|---|---|---|---|---|---|--|---|---|---|---|--------------------|
| | |  |  |  |  |  |  |  |  |  |  |  |  | |
| 9.0 m 30.0 ft | kg lb | | | | | | | | | | | *14 750 *32,750 | *14 750 *32,750 | 7350 290 |
| 7.5 m 25.0 ft | kg lb | | | | | | | *17 400 *38,150 | *17 400 *38,150 | | | *13 950 *30,800 | *13 950 *30,800 | 8460 330 |
| 6.0 m 20.0 ft | kg lb | | | | | *20 950 *45,300 | *20 950 *45,300 | *18 250 *39,750 | *18 250 *39,750 | *16 850 *30,400 | 14 250 *30,400 | *13 750 *30,300 | 13 750 *30,300 | 9190 360 |
| 4.5 m 15.0 ft | kg lb | | | *32 500 *69,550 | *32 500 *69,550 | *23 850 *51,450 | *23 850 *51,450 | *19 700 *42,700 | 18 550 39,950 | *17 350 *37,800 | 13 900 29,900 | *14 000 *30,750 | 12 450 27,550 | 9630 380 |
| 3.0 m 10.0 ft | kg lb | | | | | *26 650 *57,500 | 24 650 53,150 | *21 150 *45,850 | 17 750 38,200 | *18 000 *39,150 | 13 500 29,050 | *14 600 *32,150 | 11 800 26,050 | 9820 390 |
| 1.5 m 5.0 ft | kg lb | | | | | *28 400 *61,400 | 23 600 50,800 | *22 250 *48,200 | 17 050 36,750 | 18 350 *39,450 | 13 150 28,250 | *15 750 *34,650 | 11 650 25,700 | 9770 390 |
| 0 m 0 ft | kg lb | | | *30 800 *71,400 | *30 800 *71,400 | *28 650 *62,100 | 23 000 49,550 | *22 550 *48,850 | 16 650 35,850 | 18 100 *38,950 | 12 900 27,800 | 16 800 *37,050 | 12 050 26,500 | 9480 380 |
| -1.5 m -5.0 ft | kg lb | *25 350 *57,300 | *25 350 *57,300 | *35 350 *76,850 | *35 350 *76,850 | *27 500 *59,550 | 22 900 49,250 | *21 750 *47,000 | 16 500 35,600 | | | *17 300 *38,100 | 13 050 28,800 | 8930 360 |
| -3.0 m -10.0 ft | kg lb | *38 200 *83,200 | *38 200 *83,200 | *31 100 *67,400 | *31 100 *67,400 | *24 650 *53,200 | 23 100 49,750 | *19 200 *41,100 | 16 700 36,100 | | | *17 050 *37,550 | 15 200 33,700 | 8070 320 |
| -4.5 m -15.0 ft | kg lb | | | *24 150 *51,700 | *24 150 *51,700 | *18 950 *40,100 | *18 950 *40,100 | | | | | *15 800 *34,600 | *15 800 *34,600 | 6760 270 |



ISO 10567



*Indicates that the load is limited by hydraulic lifting capacity rather than tipping load. The above loads are in compliance with hydraulic excavator lift capacity standard ISO 10567:2007. They do not exceed 87% of hydraulic lifting capacity or 75% of tipping load. Weight of all lifting accessories must be deducted from the above lifting capacities. Lifting capacities are based on the machine standing on a firm, uniform supporting surface. The use of a work tool attachment point to handle/lift objects, could affect the machine lift performance.

Lift capacity stays with ±5% for all available track shoes.

Always refer to the appropriate Operation and Maintenance Manual for specific product information.

374F L Hydraulic Excavator Specifications

Mass Boom Lift Capacities – Counterweight: 11 mt (24,250 lb) – without Bucket

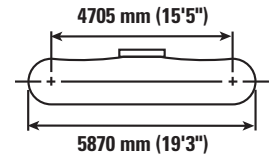
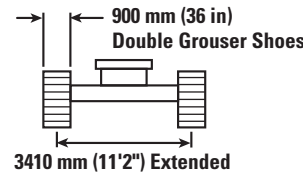
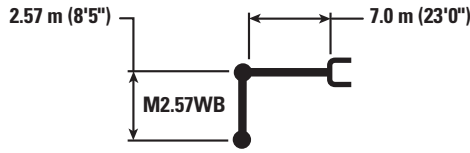

| Reach | Unit | 3.0 m/10.0 ft | | 4.5 m/15.0 ft | | 6.0 m/20.0 ft | | 7.5 m/25.0 ft | | 9.0 m/30.0 ft | | mm in | | |
|--------------------|----------|---------------|--------------------|--------------------|--------------------|--------------------|--------------------|--------------------|--------------------|--------------------|------------------|--------------------|--------------------|-------------|
| | | kg lb | kg lb | kg lb | kg lb | kg lb | kg lb | kg lb | kg lb | kg lb | kg lb | kg lb | kg lb | |
| 9.0 m 30.0 ft | kg lb | | | | | | | | | | | *17 650 *39,250 | *17 650 *39,250 | 6820 270 |
| 7.5 m 25.0 ft | kg lb | | | | | | | *18 450 *40,450 | *18 450 *40,450 | | | *16 650 *36,750 | *16 650 *36,750 | 8010 320 |
| 6.0 m 20.0 ft | kg lb | | | | | *22 050 *47,750 | *22 050 *47,750 | *19 100 *41,600 | *19 100 41,250 | | | *16 400 *36,100 | 14 800 32,850 | 8770 350 |
| 4.5 m 15.0 ft | kg lb | | | | | *24 900 *53,700 | *24 900 *53,700 | *20 400 *44,250 | 18 450 39,750 | *18 000 *39,200 | 13 900 29,800 | *16 700 *36,750 | 13 300 29,450 | 9230 370 |
| 3.0 m 10.0 ft | kg lb | | | | | *27 500 *59,350 | 24 500 52,800 | *21 750 *47,100 | 17 700 38,150 | *18 500 *40,150 | 13 500 29,100 | 17 450 38,450 | 12 600 27,800 | 9430 380 |
| 1.5 m 5.0 ft | kg lb | | | | | *28 850 *62,400 | 23 550 50,700 | *22 600 *49,000 | 17 100 36,850 | 18 400 39,650 | 13 200 28,450 | 17 350 38,150 | 12 450 27,450 | 9380 370 |
| 0 m 0 ft | kg lb | | | *28 500 *66,800 | *28 500 *66,800 | *28 650 *62,150 | 23 150 49,800 | *22 650 *49,050 | 16 750 36,100 | 18 250 13 050 | 18 250 13 050 | 18 050 39,700 | 12 900 28,450 | 9080 360 |
| -1.5 m -5.0 ft | kg lb | | *58,250 | *58,250 | *33 950 *73,900 | *33 950 *73,900 | *27 050 *58,650 | 23 100 49,700 | *21 450 *46,350 | 16 700 36,000 | | *18 050 *39,800 | 14 150 31,200 | 8510 340 |
| -3.0 m -10.0 ft | kg lb | | *33 600 *73,450 | *33 600 *73,450 | *29 250 *63,450 | *29 250 *63,450 | *23 600 *50,950 | 23 450 50,450 | *18 000 | 17 050 | | *17 600 *38,650 | 16 800 37,300 | 7590 300 |
| -4.5 m -15.0 ft | kg lb | | | | *21 400 *45,650 | *21 400 *45,650 | *16 450 | *16 450 | | | | *15 600 *33,900 | *15 600 *33,900 | 6180 240 |



ISO 10567



*Indicates that the load is limited by hydraulic lifting capacity rather than tipping load. The above loads are in compliance with hydraulic excavator lift capacity standard ISO 10567:2007. They do not exceed 87% of hydraulic lifting capacity or 75% of tipping load. Weight of all lifting accessories must be deducted from the above lifting capacities. Lifting capacities are based on the machine standing on a firm, uniform supporting surface. The use of a work tool attachment point to handle/lift objects, could affect the machine lift performance.

Lift capacity stays with ±5% for all available track shoes.

Always refer to the appropriate Operation and Maintenance Manual for specific product information.

374F L Hydraulic Excavator Specifications

Work Tool Offering Guide*

| Boom Type | Reach Boom 7.8 m (25'7") | | | Mass Boom 7.0 m (23'0") | |
|-----------------------------------|---|---|---|---|---|
| | R4.67 m (15'4") | R3.60 m (11'10") | R2.84 m (9'4") | M2.57 m (8'5") | M3.0 m (9'10") |
| Stick Size | | | | | |
| Hydraulic Hammer | H160E s H180E s | H160E s H180E s | H160E s H180E s | H160E s H180E s | H160E s H180E s |
| Multi Processor | MP40 CC Jaw MP40 CR Jaw MP40 PS Jaw MP40 S Jaw | MP40 CC Jaw MP40 CR Jaw MP40 PS Jaw MP40 S Jaw | MP40 CC Jaw MP40 CR Jaw MP40 PS Jaw MP40 S Jaw | MP40 CC Jaw MP40 CR Jaw MP40 PS Jaw MP40 S Jaw | MP40 CC Jaw MP40 CR Jaw MP40 PS Jaw MP40 S Jaw |
| Crusher | P360 | P360 | P360 | P360 | P360 |
| Mobile Scrap and Demolition Shear | S365C S385C | S365C S385C | S365C S385C | S365C S385C | S365C S385C |
| Orange Peel Grapple | These work tools are available for the 374F L. Consult your Cat dealer for proper match. | | | | |
| Clamshell | | | | | |
| Rippers | | | | | |
| Cat Quick Coupler | | | | | |

*Matches are dependent on excavator configurations. Consult your Cat dealer for proper work tool match.

374F L Hydraulic Excavator Specifications

Bucket Specifications and Compatibility

| Boom Type | Linkage | Width | | Capacity | | Weight | | Fill Factor | Reach | | Mass | | Reach | | Mass | |
|--|---------|-------|----|----------------|-----------------|--------|--------|-------------|-------------------|----------------|---------------|----------------|-------------------|---------------|----------------|--------|
| | | | | | | | | | 3.60 m (11'10") | 4.67 m (15'4") | 2.57 m (8'5") | 3.00 m (9'10") | 3.60 m (11'10") | 2.57 m (8'5") | 3.00 m (9'10") | |
| Stick Type | Tracks | mm | in | m ³ | yd ³ | kg | lb | % | 650 mm (26 in) DG | | | | 900 mm (36 in) DG | | | |
| Without Quick Coupler | | | | | | | | | | | | | | | | |
| General Duty (GD) | VB2 | 1525 | 60 | 2.90 | 3.90 | 3205 | 7,064 | 100 | ● | ⊙ | | | | ● | | |
| | VB2 | 1900 | 75 | 3.80 | 5.00 | 3622 | 7,982 | 100 | ⊖ | ○ | | | | ⊙ | | |
| | VB2 | 1900 | 75 | 3.80 | 5.00 | 3720 | 8,198 | 100 | ⊖ | ○ | | | | ⊖ | | |
| | WB2 | 2000 | 79 | 4.60 | 6.00 | 4016 | 8,851 | 100 | | | ● | ⊙ | | | ● | ⊙ |
| | WB2 | 2100 | 83 | 5.00 | 6.50 | 4167 | 9,184 | 100 | | | ⊙ | ⊖ | | | ⊙ | ⊙ |
| General Duty XL (GDXL) | VB2 | 2000 | 79 | 4.60 | 6.00 | 4077 | 8,986 | 100 | ○ | ◇ | | | | ○ | | |
| Heavy Duty (HD) | VB2 | 1220 | 48 | 2.20 | 2.90 | 2892 | 6,373 | 100 | ● | ● | | | | ● | | |
| | VB2 | 1700 | 66 | 3.30 | 4.30 | 3529 | 7,778 | 100 | ⊙ | ⊖ | | | | ● | | |
| | VB2 | 1900 | 75 | 3.80 | 5.00 | 3881 | 8,553 | 100 | ⊖ | ○ | | | | ⊖ | | |
| | VB2 | 1900 | 75 | 3.80 | 5.00 | 3782 | 8,336 | 100 | ⊖ | ○ | | | | ⊖ | | |
| | WB2 | 2100 | 83 | 5.00 | 6.50 | 4345 | 9,576 | 100 | | | ⊙ | ⊖ | | | ⊙ | ⊖ |
| | WB2 | 2250 | 89 | 5.30 | 7.00 | 4591 | 10,119 | 100 | | | ⊖ | ⊖ | | | ⊙ | ⊖ |
| Severe Duty (SD) | VB2 | 1100 | 43 | 1.90 | 2.50 | 2840 | 6,259 | 90 | ● | ● | | | | ● | | |
| | VB2 | 1525 | 60 | 2.90 | 3.90 | 3453 | 7,610 | 90 | ● | ⊙ | | | | ● | | |
| | VB2 | 1700 | 66 | 3.30 | 4.30 | 3653 | 8,051 | 90 | ● | ⊖ | | | | ● | | |
| | VB2 | 1900 | 75 | 3.80 | 5.00 | 4016 | 8,851 | 90 | ⊙ | ○ | | | | ⊙ | | |
| | WB2 | 1800 | 71 | 3.70 | 4.80 | 4667 | 10,286 | 90 | | | ● | ● | | | ● | ● |
| | WB2 | 1900 | 75 | 4.00 | 5.25 | 4825 | 10,634 | 90 | | | ● | ● | | | ● | ● |
| | WB2 | 2000 | 79 | 4.40 | 5.75 | 4982 | 10,980 | 90 | | | ● | ⊙ | | | ● | ⊙ |
| | WB2 | 2100 | 83 | 4.60 | 6.00 | 5141 | 11,331 | 90 | | | ● | ⊙ | | | ● | ⊙ |
| | WB2 | 2200 | 87 | 4.60 | 6.00 | 5227 | 11,523 | 90 | | | ⊙ | ⊙ | | | ● | ⊙ |
| | WB2 | 2200 | 87 | 5.00 | 6.50 | 5341 | 11,772 | 90 | | | ⊙ | ⊖ | | | ⊙ | ⊖ |
| Extreme Duty (XD) | VB2 | 1900 | 75 | 3.80 | 5.00 | 4806 | 10,592 | 90 | ⊖ | ◇ | | | | ⊖ | | |
| | WB2 | 1900 | 75 | 4.00 | 5.25 | 5587 | 12,317 | 90 | | | ● | ⊙ | | | ● | ● |
| | WB2 | 2000 | 79 | 4.40 | 5.75 | 5785 | 12,750 | 90 | | | ⊙ | ⊖ | | | ● | ⊙ |
| | WB2 | 2100 | 83 | 4.40 | 5.75 | 5866 | 12,932 | 90 | | | ⊙ | ⊖ | | | ● | ⊙ |
| | WB2 | 2150 | 86 | 4.60 | 6.00 | 5982 | 13,188 | 90 | | | ⊙ | ⊖ | | | ⊙ | ⊖ |
| | WB2 | 2200 | 87 | 5.00 | 6.50 | 6171 | 13,605 | 90 | | | ⊖ | ○ | | | ⊖ | ⊖ |
| Extreme Duty Granite (XDG) | WB2 | 2000 | 79 | 4.37 | 5.75 | 5992 | 13,206 | 90 | | | ⊙ | ⊖ | | | ● | ⊙ |
| | WB2 | 2100 | 83 | 4.64 | 6.00 | 6224 | 13,718 | 90 | | | ⊙ | ⊖ | | | ⊙ | ⊖ |
| Maximum load pin-on (payload + bucket) | | | | | | | | | kg | 9892 | 8297 | 13 482 | 12 450 | 10 177 | 13 854 | 12 801 |
| | | | | | | | | | lb | 21,802 | 18,287 | 29,714 | 27,440 | 22,430 | 30,534 | 28,213 |
| With Quick Coupler (CW-70) | | | | | | | | | | | | | | | | |
| General Duty (GD) | VB2 | 1900 | 75 | 3.80 | 5.00 | 3668 | 8,084 | 100 | ○ | ⊗ | | | | ○ | | |
| Severe Duty (SD) | WB2 | 1900 | 75 | 4.00 | 5.25 | 4802 | 10,584 | 90 | | | ⊙ | ⊖ | | | ● | ⊙ |
| | WB2 | 2000 | 79 | 4.40 | 5.75 | 4959 | 10,930 | 90 | | | ⊙ | ⊖ | | | ⊙ | ⊖ |
| Extreme Duty (XD) | WB2 | 2000 | 79 | 4.40 | 5.75 | 5797 | 12,777 | 90 | | | ⊖ | ○ | | | ⊖ | ○ |
| Maximum load pin-on (payload + bucket) | | | | | | | | | kg | 8572 | 6977 | 12 162 | 11 130 | 8857 | 12 534 | 11 481 |
| | | | | | | | | | lb | 18,893 | 15,377 | 26,805 | 24,531 | 19,521 | 27,625 | 25,304 |

The above loads are in compliance with hydraulic excavator standard EN474, they do not exceed 87% of hydraulic lifting capacity or 75% of tipping capacity with front linkage fully extended at ground line with bucket curled.

Capacity based on ISO 7451.

Bucket weight with Long tips.

Maximum Material Density:

- 2100 kg/m³ (3,500 lb/yd³)
- ⊙ 1800 kg/m³ (3,000 lb/yd³)
- ⊖ 1500 kg/m³ (2,500 lb/yd³)
- 1200 kg/m³ (2,000 lb/yd³)
- ◇ 900 kg/m³ (1,500 lb/yd³)
- ⊗ Not Recommended

Caterpillar recommends using appropriate work tools to maximize the value customers receive from our products. Use of work tools, including buckets, which are outside of Caterpillar's recommendations or specifications for weight, dimensions, flows, pressures, etc. may result in less-than-optimal performance, including but not limited to reductions in production, stability, reliability, and component durability. Improper use of a work tool resulting in sweeping, prying, twisting and/or catching of heavy loads will reduce the life of the boom and stick.

374F L Standard Equipment

Standard Equipment

Standard equipment may vary. Consult your Cat dealer for details.

CAB

- Parallel wiper and washer
- Mirrors
- Pressurized operator station with positive filtration
- Laminated glass front upper window and tempered other windows
- Sliding upper door window (left-hand cab door)
- Removable lower windshield with in cab storage bracket
- Openable skylight
- Interior:
 - Glass-breaking safety hammer
 - Coat hook
 - Beverage holder
 - Literature holder
 - Interior lighting
 - AM/FM radio mounting (DIN size)
 - Two 12V stereo speakers
 - Storage shelf suitable for lunch or toolbox
 - Power supply with 12V, two power outlets (10 amp)
 - Thumb wheel modulation joystick for use with combined auxiliary control
 - Sun screen
 - Air conditioner, heater and defroster with climate control
- Seat:
 - Seat belt, 51 mm (2 in)
 - Adjustable armrest
 - Height adjustable joystick consoles
 - Neutral lever (lock out) for all controls
 - Travel control pedals with removable hand levers
 - Capability of installing two additional pedals
 - Two speed travel
 - Floor mat, washable

Monitor:

- Clock
- Video ready
- Color LCD display with warning, filter/fluid change, and working hour information
- Language display (full graphic and full color display)
- Machine condition, error code and tool mode setting information
- Start-up level check for engine oil, engine coolant and hydraulic oil
- Warning, filter/fluid change and working hour information
- Fuel consumption meter

ELECTRICAL

- 80 amp alternator
- Circuit breaker
- Battery, standard

ENGINE

- C15 ACERT diesel engine
- U.S. EPA Tier 2, EU Stage II, Japan 2001 (Tier 2) equivalent or U.S. EPA Tier 3, Stage IIIA, Japan 2006 (Tier 3) equivalent, China Nonroad Stage III emission package
- 2300 m (7,500 ft) altitude capability with no derate
- Up to B20 biodiesel capable
- Automatic engine speed control
- Water separator in fuel line including water level sensor and indicator
- Economy and standard power modes
- Air cleaner
- Side-by-side cooling system
- Steel wall between engine and pump compartment
- Primary filter with water separator and water separator indicator switch
- Starting kit, cold weather, -18°C (-0.4°F)
- Primary fuel filter
- Secondary fuel filter
- Tertiary fuel filter

HYDRAULIC SYSTEM

- Reverse swing dampening valve
- Automatic swing parking brake
- High-performance hydraulic return filter
- Regeneration circuit for boom and stick
- Capability of installing additional auxiliary circuits
- Reversing cooling fan
- Bio oil capable

LIGHTS

- Cab and boom lights with time delay
- Exterior lights integrated into storage box

UNDERCARRIAGE/UPPERFRAME

- Grease Lubricated Track with PPR2 GLT4, resin seal
- Heavy duty track roller and idler
- Heavy duty track motor guards
- Towing eye on base frame
- Heavy duty bottom guards on upperframe
- Counterweight with lifting eye
- Swivel guard

SAFETY AND SECURITY

- Cat one key security system
- Door locks
- Cap locks on fuel and hydraulic tanks
- Lockable external tool/storage box
- Signaling/warning horn
- Secondary engine shutoff switch
- Mirrors
- Rear window for emergency exit
- Capability to connect a beacon
- Bolt on FOGS capability
- Service walkways
- Safety hammer for breaking cab glass

Optional Equipment

Optional equipment may vary. Consult your Cat dealer for details.

FRONT LINKAGE

- Reach boom 7.8 m (25'7") – with or without BLCV/SLCV:
 - R4.67VB2 (15'4") – with or without CPM
 - R2.84VB2 (9'4") – without CPM
 - R3.6VB2 (11'10") – with or without CPM
 - VB2-family bucket linkage – with or without lifting eye
- Mass boom 7.0 m (23'0") – with or without BLCV/SLCV:
 - M2.57WB2 (8'6") – with/without CPM
 - M3.0WB2 (9'10") – without CPM
 - WB2-family bucket linkage – with or without lifting eye
- Universal Quick Coupler

TRACK

- 750 mm (26 in) double grouser heavy duty
- 650 mm (30 in) double grouser heavy duty
- 900 mm (36 in) double grouser heavy duty

COUNTERWEIGHT

- With removal device
- Fixed

ENGINE

- Quick drains, engine and hydraulic oil (QuickEvac)
- Fast fill port for fuel
- Electric priming pump with switch

GUARDS

- FOGS (Falling Object Guard System) including overhead and windshield guards
- Track guiding guards:
 - Full length
 - Segmented, three pieces
 - Center section

LIGHTS

- Cab working lights, halogen
- Cab working lights, HID
- Boom working lights, halogen
- Boom working lights, HID

CAB

- Seat:
 - Adjustable high-back, heated and ventilated seat with air suspension
 - Adjustable high-back seat with mechanical suspension
 - Adjustable high-back, heated seat with air suspension
- Windshield:
 - 70-30 split, sliding
 - One piece, fixed
- Straight travel pedal

HYDRAULIC SYSTEM

- Boom and stick lowering control devices with SmartBoom
- Counterweight removal device
- HP hydraulic lines for boom and stick
- MP hydraulic lines for boom and stick
- QC hydraulic lines for boom and stick
- Universal QC control
- Bio oil

ELECTRICAL

- Cold weather starting package
- Travel alarm
- Electric refueling pump

CAT CONNECT TECHNOLOGIES

- Cat Product Link
- Rearview camera
- Side-view camera
- Cat Production Measurement (CPM)

For more complete information on Cat products, dealer services, and industry solutions, visit us on the web at www.cat.com

AEHQ7885
(AME, CIS, Turkey, AmS, APD)

© 2016 Caterpillar
All rights reserved

Materials and specifications are subject to change without notice. Featured machines in photos may include additional equipment. See your Cat dealer for available options.

CAT, CATERPILLAR, SAFETY.CAT.COM, their respective logos, "Caterpillar Yellow" and the "Power Edge" trade dress, as well as corporate and product identity used herein, are trademarks of Caterpillar and may not be used without permission.

VisionLink is a trademark of Trimble Navigation Limited, registered in the United States and in other countries.

