

Service Manual

RP2500 and RP3100 Low Power Generator Sets

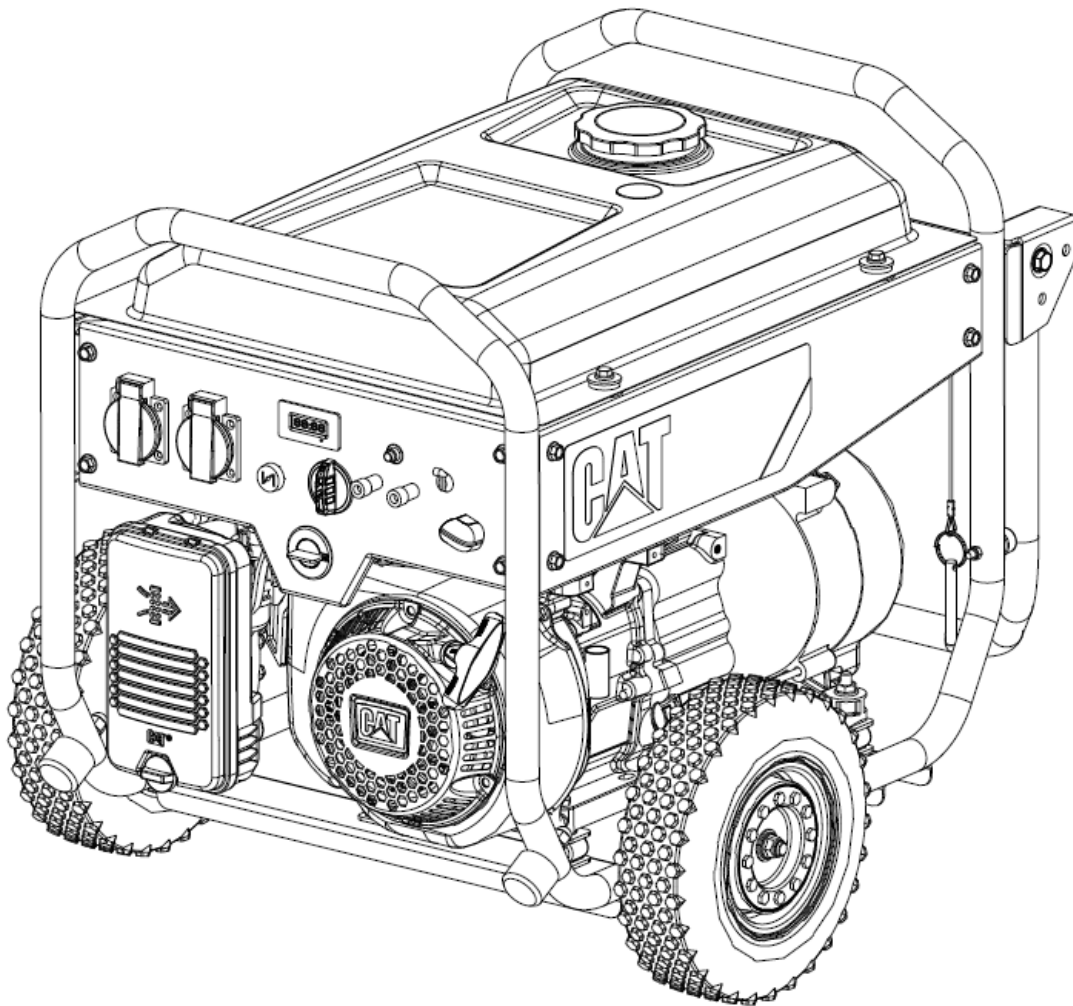

Important Safety Information

Most accidents that involve product operation, maintenance and repair are caused by failure to observe basic safety rules or precautions. An accident can often be avoided by recognizing potentially hazardous situations before an accident occurs. A person must be alert to potential hazards, including human factors that can affect safety. This person shall also have the necessary training, skills and tools to perform these functions properly.

Safety precautions and warnings are provided in this manual and on the product. If these hazard warnings are not heeded, bodily injury or death could occur to you or to other persons.

Caterpillar cannot anticipate every possible circumstance that might involve a potential hazard. The warnings in this publication and on the product are, therefore, not all inclusive. You must not use this product in any manner different from that considered by this manual without first satisfying yourself that you have considered all safety rules and precautions applicable to the operation of the product in the location of use, including site-specific rules and precautions applicable to the worksite. If a tool, procedure, work method or operating technique that is not specifically recommended by Caterpillar is used, you must satisfy yourself that it is safe for you and for others. You should also ensure that you are authorized to perform this work, and that the product will not be damaged or become unsafe by the operation, lubrication, maintenance or repair procedures that you intend to use.

The information, specifications, and illustrations in this publication are on the basis of information that was available at the time that the publication was written. The specifications, torques, pressures, measurements, adjustments, illustrations, and other items can change at any time. These changes can affect the service that is given to the product. Obtain the complete and most current information before you start any job.

This manual contains safety, maintenance, troubleshooting, and disassembly and assembly information. This manual should be stored near the product. Read, study and keep it with the literature and product information.

Table of Contents

SAFETY MESSAGES	5
Additional Messages	6
COMPONENT IDENTIFICATION.....	8
European Union	8
United Kingdom.....	8
Engine Type & Serial Number.....	9
CE and Ratings Plate	9
MAINTENANCE.....	10
Regularly Scheduled Maintenance	10
Special Tools.....	10
Maintenance and Service Procedures	10
Air Filter – Check.....	10
Brush – Inspect/Repair/Replace	11
Camshaft – Inspect/Replace.....	11
Carburetor – Inspect/Adjust	11
Control Panel – Service	12
Crankshaft – Inspect/Replace.....	14
Cylinder Pressure – Check	14
Engine Oil Level – Check	14
Engine Oil – Change	15
Engine Speed – Adjust	15
Engine Valve – Inspect/Replace	15
Engine Valve Lash – Adjust.....	18
Flywheel - Install.....	18
Fuel Line and Filter – Replace	19
Fuel Tank Cap and Strainer – Clean	19
Generator - Inspect.....	19
Generator - Flash	19
Governor - Adjust	20
Ignition Coil – Test/Adjust	20
Insulation - Test.....	21
Exhaust Silencer – Inspect/Replace	21
Piston – Inspect/Replace	22
Recoil Starter Spring - Install	23
Spark – Check.....	24
Screen - Inspect/Clean/Replace	24
Spark Plug – Inspect/Adjust/Replace	25

Timing Gear – Inspect/Replace	25
Voltage Regulator – Replace	26
Walk-Around Inspection	26
Windings – Test.....	26
STORAGE	27
Storage for 1 – 3 months	27
Storage for more than 3 months	27
DIAGRAMS.....	28
Air Filter Assembly.....	28
Carburetor	29
Control Panel.....	30
Control Panel.....	31
Flywheel	34
Fuel Tank	34
Exhaust Silencer	36
Recoil Starter.....	37
TROUBLESHOOTING	38
APPENDIX.....	42
Product Specifications	42
Maintenance Specifications	43
Electrical Schematic European Union.....	44
Electrical Schematic United Kingdom	45

SAFETY MESSAGES

There may be several specific safety messages on your generator. Please become familiar with all safety messages.

Ensure that all of the safety messages are legible. Clean the safety messages or replace the safety messages if the words cannot be read or if the illustrations are not visible. Use a cloth, water, and soap to clean the safety messages. Do not use solvents, gasoline, or other harsh chemicals. Solvents, gasoline, or harsh chemicals could loosen the adhesive that secures the safety messages.

Replace any safety message that is damaged or missing. If a safety message is attached to a part of the generator that is replaced, install a new safety message on the replacement part.



Be Alert!

This symbol identifies a potential hazard that could cause injury or property damage.

Protect children by keeping them at a safe distance from the generating set.



Read the Manual

WARNING

Do not operate or work on this generator unless you have read and understand the instructions and warnings in the Owner's Manual. Failure to follow the instructions or heed the warnings could result in injury or death. Proper care is your responsibility.



Carbon Monoxide

Operating a generator indoors can kill you in minutes. Generator exhaust contains carbon monoxide. Carbon monoxide is a poison that you cannot see or smell. Never operate a generator inside a home or garage, even if doors and windows are open. Only operate a generator outdoors and away from windows,

doors, and vents. Always consider wind direction and intensity to ensure carbon monoxide is blown away from structures and other places where people and animals may be present. If anyone experiences dizziness, headaches, nausea, or tiredness get to fresh air immediately and seek medical attention.

Fuel Warning / No Open Flames

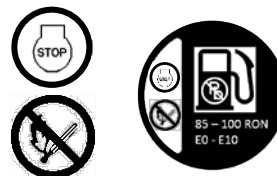

Gasoline is a highly flammable liquid and the vapor can explode. Do not refuel the unit near open flames. Do not refuel the unit while the engine is running. Do not smoke while refueling. Allow the engine to cool before refueling. Do not overfill the tank. Only use regular unleaded gasoline in the 85 – 100 RON range in this product. Do not use gasoline that has more than 10% ethanol content.

Before Starting the Unit



Be alert! Read the Owner's Manual before starting the unit. You must add fuel and oil before starting the unit.



Pinching or Crushing Hazard

The handle is a potential pinching or crushing hazard. Use caution when inserting or removing the handle pin. To prevent damage to the handle paint, insert pin before using handle in the up position.



Use Proper Lifting Techniques

Do not attempt to lift the unit by yourself. Lift as a team or use a proper lifting device such as a sling to lift the unit. If lifting as a team, hold the unit by the frame, keep your back straight, and lift with your legs. Use your legs to lower the unit when setting it down.

Hot Surface / Do Not Touch



Hot parts or hot components can cause burns or personal injury. Do not allow hot parts or components to contact your skin. Use protective clothing or protective equipment to protect your skin.



Shock/Electrocution

Do not operate this equipment or work on this equipment unless you have read and understand the instructions and warnings in the Owner's Manual. Failure to follow the instructions or heed the warnings will result in serious injury or death.

Do not connect generator to a utility electrical distribution system unless it is isolated from the system. Electrical feedback into the distribution system can occur and could cause personal injury or death.

Do not operate this product in wet conditions.

Hot Surface / Do Not Touch / Fire



Hot parts or hot components can cause burns or personal injury. Do not allow hot parts or components to contact your skin. Use protective clothing or protective equipment to protect your skin.

Hot exhaust presents a potential fire hazard. Be sure that nothing flammable is within 3 meters of the exhaust.

Additional Messages

Earth Ground



This symbol identifies the earth ground connection. Refer to the article "Generator Grounding" for additional information on grounding the generator.

Oil Fill / Measure

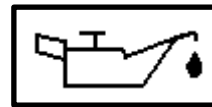

This symbol identifies the location of the oil fill and oil level check point.

Oil Drain

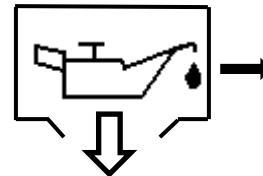

This symbol identifies the location of the oil drain point.

Special Requirements

Electrical equipment, including lines and plug connections should be covered and protected from moisture.

The circuit breakers and overcurrent protectors should match the generator specifications. If a circuit breaker or overcurrent protector requires replacement, it must be replaced with a circuit

breaker or overcurrent protector of the same rating and performance characteristics.

In any generator set installation, the frame of the generator must be connected to an effective earth ground. A ground terminal is provided.

For 115VAC, use extension cables rated for 115V at 16A or greater. For 230VAC, use extension cables rated for 230V at 32A or greater. Use the shortest extension cable that meets these requirements.

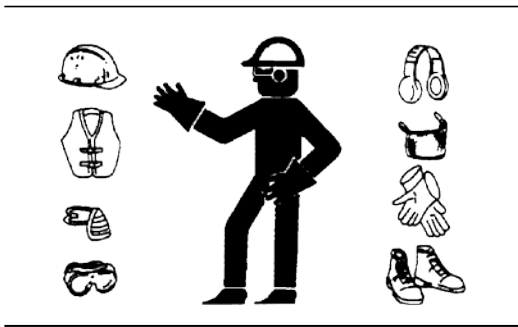

- Wear a hard hat, protective glasses, and other protective equipment, as required.
- When work is performed around an engine that is operating, wear protective devices for ears in order to help prevent damage to hearing.
- Do not wear loose clothing or jewelry that can snag on controls or on other parts of the engine.
- Ensure that all protective guards and all covers are secured in place on the engine.
- Never put maintenance fluids into glass containers. Glass containers can break.
- Use all cleaning solutions with care.

COMPONENT IDENTIFICATION

European Union

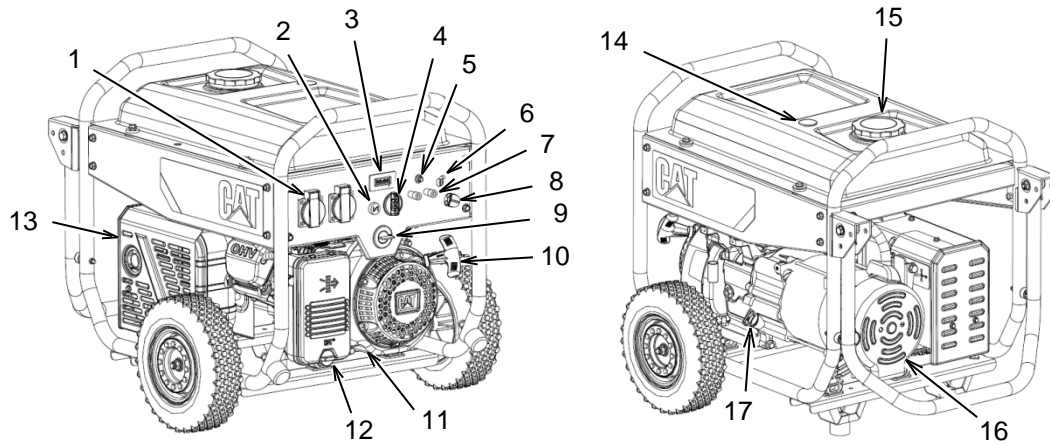

United Kingdom

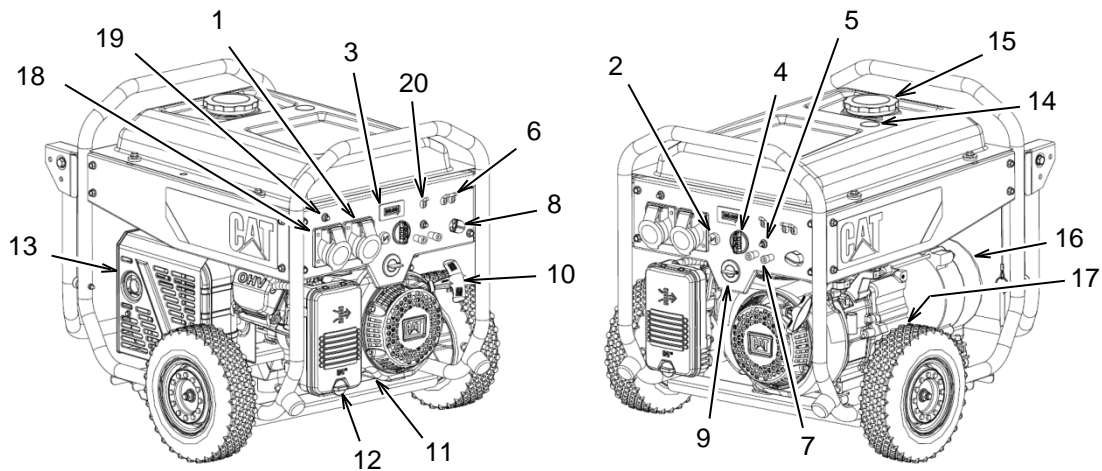

- 1) Receptacle – 230 VAC
- 2) Choke Knob
- 3) Display
- 4) Generator Switch
- 5) DC Overcurrent protector
- 6) AC Manual Circuit Breaker
- 7) DC Terminals
- 8) Panel Light
- 9) Fuel Valve
- 10) Recoil Start Assembly

- 11) Oil Drain
- 12) Air Filter Assembly
- 13) Exhaust Silencer
- 14) Fuel Gauge
- 15) Fuel Cap
- 16) Alternator
- 17) Oil Gauge / Oil Fill
- 18) Receptacle – 115VAC
- 19) AC Overcurrent protector
- 20) Voltage Selector Switch (UK only)

Engine Type & Serial Number

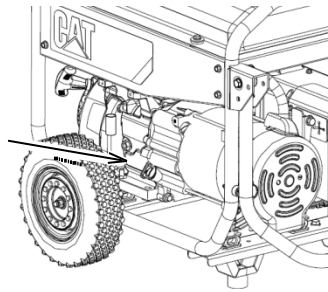

Cat® portable generators are identified with model numbers, serial numbers, and with performance specification numbers. The serial number is engraved on the engine block near the oil fill.

CE and Ratings Plate

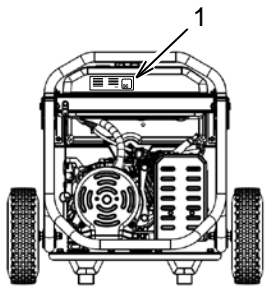

Note: The CE plate is on products that are certified to the European Union requirements that were effective at that time.

Several pieces of information are printed on the CE plate.

For machines that are compliant to “2006/42/EC”, the following information is printed on the CE plate.

- Rated Power (kW)
- Power Factor
- Frequency (Hz)
- Typical Machine Weight (kg)
- Voltage (V)
- Rated Current (A)
- Year of Construction
- Machine Type
- Performance Class
- Quality Class
- Sound level

MAINTENANCE

Regularly Scheduled Maintenance

Included below are the intervals for normal maintenance of the product. The Maintenance and Service Procedures section includes normal maintenance procedures and more detailed service procedures that the typical user may not be able to perform. DO NOT attempt any procedures that you are not qualified to perform.

Ensure that all safety information, warnings, and instructions are read and understood before any operation or any maintenance procedures are performed.

Use service hours or calendar time, WHICH EVER OCCURS FIRST, to determine the correct maintenance intervals.

Stop the engine before servicing. Put the engine in horizontal position and remove the spark plug cap to prevent the engine from starting. Never operate the engine in an unventilated room or other enclosed area.

When Required:

Fuel Tank Cap and Strainer – Clean

Every Use:

Engine Oil Level – Check

Walk-Around Inspection

First 20 Service Hours or 1 Month:

Engine Oil – Change

Every Month:

Generator – Inspect

Every 50 Service Hours or 3 Months:

Air Filter – Check

Screen – Inspect/Clean/Replace

Every 100 Service Hours or 6 Months:

Engine Oil – Change

Spark Plug – Inspect/Adjust/Replace

Every 300 Service Hours or 1 Year:

Engine Valve Lash – Check

Every 2 Years:

Fuel Line – Replace

Special Tools

The following tools may be required to perform the service procedures:

- Bearing driver
- Bearing puller
- Compression gauge
- Float level gauge
- Flywheel driver
- Megohmmeter
- Micrometer
- Multimeter (Volts and Ohms)
- Piston driver
- Piston ring puller
- Ring compressor
- Valve guide driver
- Valve guide reamer
- Valve seat cutter 32°
- Valve seat cutter 45°

Maintenance and Service Procedures

Air Filter – Check

A dirty air filter will restrict air flow into the carburetor, will cause poor fuel economy, and may damage the engine. To keep the generator in good operating condition, service the air filter regularly. Service the air filter more often when operating the generator in extremely dusty areas.

Note: Never operate the generator without the air filter in place. Operating the generator without the air filter in place will result in rapid engine wear.

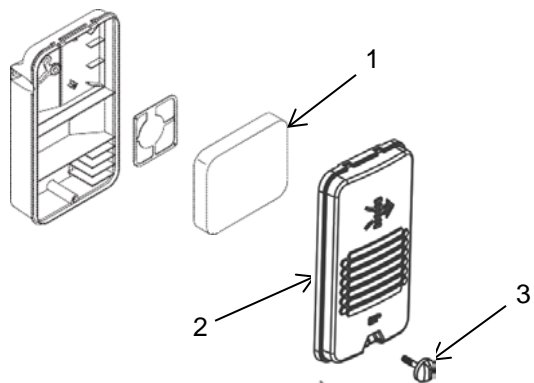

Remove the air filter cover bolt (3) and remove the air filter cover (2). Make sure that the air filter (1) is clean and not damaged. If the air filter is dirty, wash the filter. If the air filter is damaged, replace the air filter.

Use a nonflammable solvent or a mixture of household detergent and warm water to wash the filter. Rinse the filter thoroughly to remove all of the cleaning solution. After the filter has dried, pour a few drops of engine oil onto the filter. Then squeeze the filter to distribute the oil throughout the filter and remove any excess oil.

Note: Do not wring out the filter. Wringing out the filter may damage the filter.

Install the filter into the filter housing. Place the air filter cover over the filter and reinstall the air filter cover bolt. Tighten the cover bolt by hand. Dispose of any waste solvent using approved waste disposal services.

Brush – Inspect/Repair/Replace

The carbon brush is located behind the cover of the alternator.

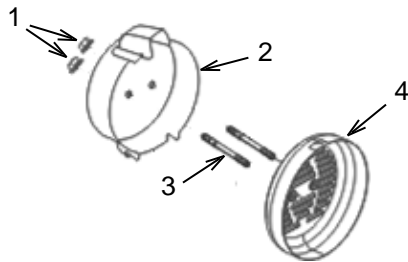

Remove nuts (1) and remove outer cover (2). Slide cover (4) off studs (3).

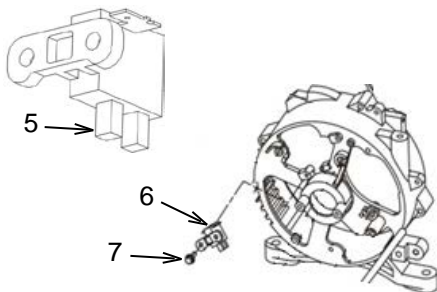

Check the length of the brushes (5). If the length is 6mm or less, replace the brush. To remove the brush, remove bolt (7) and disconnect the leads. To reinstall, connect the red lead to the “+” terminal, the white lead to the “-” terminal, then use bolt (7) to secure the new brush.

Check the contact surface between the brush (6) and the collector ring. If the contacting surface appears to be less than 75% of the brush surface, resurface the brush. Put emery cloth

between the brush and the collector ring with the grit side facing the brush. Work the emery cloth back and forth against the brush until there is more than 75% contact area. Do not just spin the collector as a charge may build in the windings. Remove any debris from the generator before reassembling.

Camshaft – Inspect/Replace

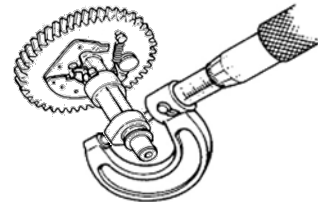

Inspect the camshaft for damage or abnormal wear. Measure the lift on the camshaft lobes. The acceptable limit for the lift is shown in the table below. If the lift is out of the acceptable range, replace the camshaft.

Lobe:	Normal Lift:	Minimum:
Intake	27.7 mm	27.45 mm
Exhaust	27.75 mm	27.5 mm

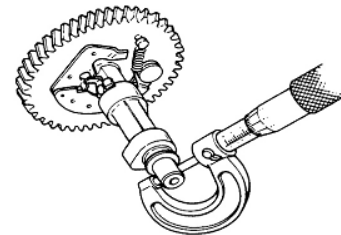

Measure the outside diameter of the camshaft. The normal diameter is 13.984 mm. If the diameter is 13.916 mm or less, replace the camshaft.

Carburetor – Inspect/Adjust



No Open Flames

Gasoline is a highly flammable liquid and the vapor can explode. Do not have or store fuel near open flames. Do not smoke while near fuel. Remove the air filter assembly. Clean the outside surface of the carburetor before disassembly.

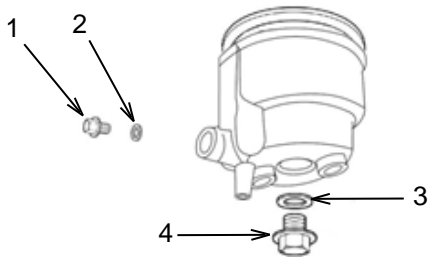

Drain the fuel from float chamber by removing drain bolt (1) and gasket (2). Use a suitable container to catch the fuel. Dispose of any waste fuel using approved waste disposal services. Remove the carburetor. Remove bolt (4) and gasket (3). Carefully remove the float chamber, and contain any small parts that may fall out.

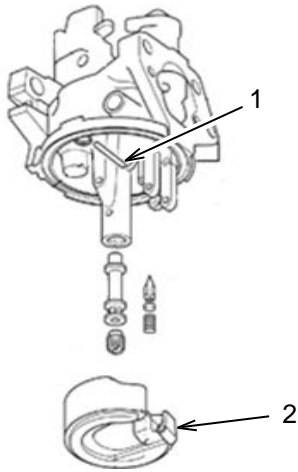

Remove float pin (1), carefully remove float (2) and contain the small parts. Clean the internal parts with carburetor cleaner and compressed air.

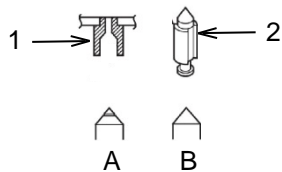

Check the float valve seat (1) and float valve (2) for wear. Figure A shows a worn float valve seat that needs replaced. Figure B shows a float valve seat that can be reused.

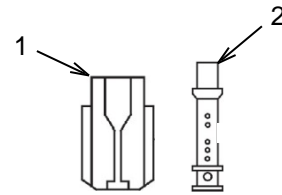

Inspect main fuel jet (1) and main fuel nozzle (2). If worn, replace.

After reinstalling the float, lightly press in with a finger to make sure the float moves freely. Make sure that the float valve is just contacting the valve seat, and the spring is not compressed.

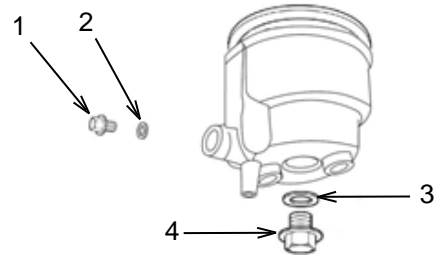

Install drain plug (1) and gasket (2) into the float chamber. Set the float chamber in place so that the drain bolt can be accessed from outside the unit. Install gasket (3) and bolt (4) to hold the float chamber in place. Reinstall the carburetor. After starting the unit, check for leakage. Bring the engine to the normal operating temperature and adjust the pilot screw to bring the engine to the proper idle speed.

Control Panel – Service

Fuel Valve:

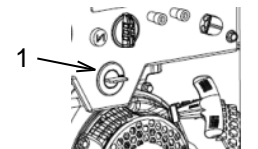

No Open Flames

Gasoline is a highly flammable liquid and the vapor can explode. Do not have or store fuel near open flames. Do not smoke while near fuel.

The fuel valve (1) can be accessed without removing the control panel. To remove the fuel valve, drain the fuel from the fuel tank into an

appropriate container. Start the engine and let the engine run out of fuel. Turn the generator switch to the off "0" position.

Move the hose clamps that hold the fuel lines to the fuel valve to the center of the fuel lines. Remove the fuel lines from the fuel valve. Remove the clip from the rear of the control panel face. Remove the fuel valve. Reinstall in reverse order.

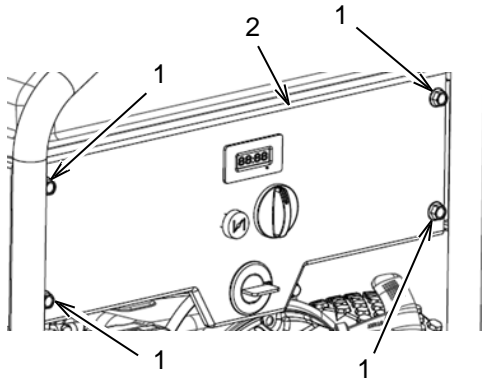

Remove bolts (1) and the washers. Pull the control panel (2) forward slowly. Make sure that the cables move freely and are not damaged. Tag the wires to identify them and then disconnect the wiring harnesses.

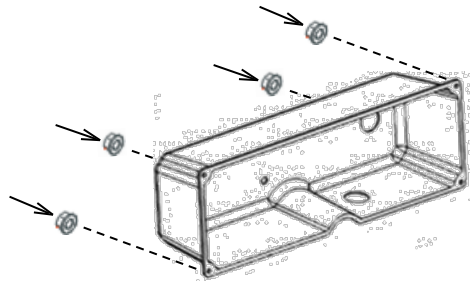

Place the front of the control panel on a surface that will protect the panel from damage. Remove the four 7mm nuts from the back of the control panel housing and carefully separate the housing from the front panel.

Choke:



The choke is held to the rear of the panel with 7mm nuts. Remove the choke knob and cable from the front of the panel, and remove the nuts that hold the choke to the panel. Remove the choke control from the rear of the panel.

Reinstall in reverse order.

Overcurrent Protectors / Circuit Breakers:

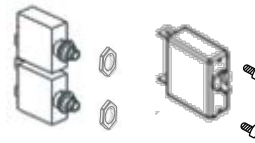

Each pushbutton overcurrent protector is held to the panel with a half nut located on the front of the panel. Switch style circuit breakers are held to the panel with machine screws. Tag the wires to identify them and then disconnect the circuit breaker or overcurrent protector. Remove the half nut from the front of the panel then remove the circuit breaker or overcurrent protector from the rear of the panel.

Display:



The display is held in place by hot melt glue. Disconnect the display from the wiring harness and remove the glue. Remove the display from the front of the panel.

Generator Switch:

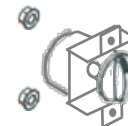

The generator switch is held to the panel with 7mm nuts. Disconnect the wiring, remove the knob from the front of the panel, and remove the nuts. Remove the generator switch from the rear of the panel.

Panel Light:

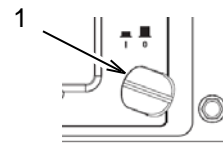

The panel light (1) is held to the panel with hot melt glue. Disconnect the panel light from the wiring and remove the glue. Remove the panel light from the front of the panel.

Receptacles:



Each receptacle is held to the panel with four machine screws. Tag the wires to identify them and then remove the wires from the receptacle. Remove the nuts that hold the receptacle to the panel, and then remove the receptacle from the rear of the panel. The receptacle cover can then be removed from the front of the panel.

Voltage Selector Switch (If equipped):



The voltage selector switch is held to the panel with a half nut located on the front of the panel. Tag the wires to identify them and then disconnect the switch. Remove the half nut from the front of the panel then remove the switch from the rear of the panel.

Crankshaft – Inspect/Replace

Inspect the crankshaft oil seal. If the seal is damaged or shows sign of leakage, replace the seal.

Inspect the crankshaft bearings. If the bearing is scored or shows signs of discoloration from excessive heat, replace the bearing. Coat the bearing with engine oil before installing.

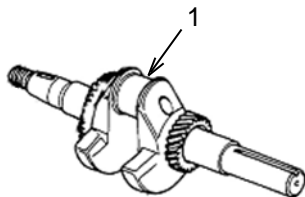

Check the diameter of the crankshaft journal (1). A normal diameter is 30.190 mm. If the diameter is 30.175 mm or less, replace the crankshaft.

When installing the crankshaft, insert it into the

crankcase until the bearing touches the crankcase without damaging the oil seal.

Cylinder Pressure – Check

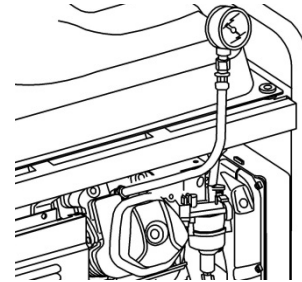

- Remove the spark plug cap and spark plug.
- Connect the compression gauge as shown above.
- Pull the recoil starter handle several times and note the cylinder pressure.
- If the cylinder pressure is not within 588 - 834 kPa, refer to the Troubleshooting section.

Engine Oil Level – Check

Always check the engine oil with the generator on a level surface and with the engine stopped.

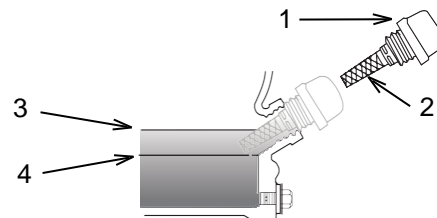

1. Remove the oil filler cap (1) and wipe the oil level gauge (2) to clean it.
2. Check the oil level by inserting the oil level gauge into the filler neck. Do not screw the oil filler cap in when checking the oil level.
3. If the oil level is low (4), add the recommended engine oil until the oil level reaches the upper mark (3). Refer to the following chart to determine which viscosity oil to use.

Recommended Lubricant Viscosities for Ambient Temperature				
Oil Viscosities	°C		°F	
	Min	Max	Min	Max
SAE 0W-40	-40	40	-40	104
SAE 5W-40	-30	50	-22	122
SAE 10W-30	-18	40	0	104
SAE 15W-40	-10	50	14	122

- After adding oil, install and tighten the oil filler cap.

Note: Non-detergent and 2-stroke engine oils will damage the engine and must not be used.

Engine Oil – Change

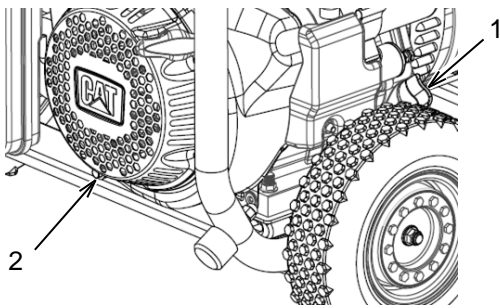

- Operate the engine until it reaches normal operating temperature (about 20 minutes). Stop the engine.
- Remove the oil filler cap (1) and drain plug (2) to drain the oil. Drain the oil into a suitable container.
- Reinstall the drain plug and tighten to 20 ± 2 N·m.
- Refill the oil and check the oil level. Refer to Engine Oil Level – Check.
- Install and tighten the oil filler cap.
- Dispose of the used oil using approved waste disposal services.

Engine Speed – Adjust

Start the engine and allow it to reach normal operating temperature.

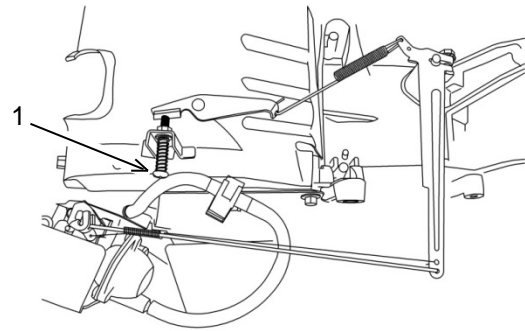

The maximum speed for this engine is 3730 – 3830 rpm. Turn the adjusting screw (1) clockwise to increase the engine speed. Turn the adjusting screw counterclockwise to decrease the engine speed. If adjusting the screw does not get the engine speed within range, see Governor – Adjust.

Engine Valve – Inspect/Replace

Remove the exhaust silencer, air filter assembly, recoil starter, shroud, carburetor, and insulator.

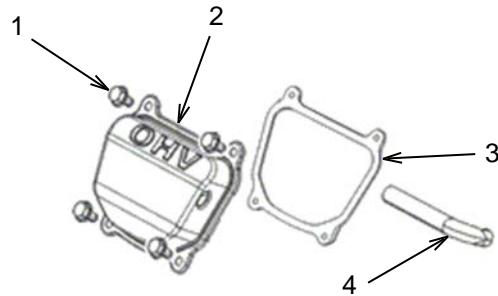

Remove valve cover bolts (1), breather tube (4), valve cover (2), and valve cover gasket (3).

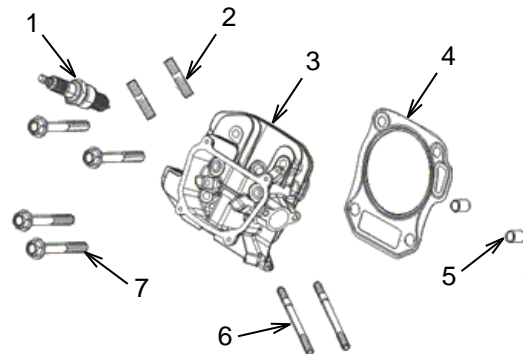

Remove spark plug (1). Remove cylinder head bolts (7), and remove cylinder head (3). Remove cylinder head gasket (4) and discard used gasket. Remove locating pins (5) and set aside. Studs (2) and (6) can remain in the cylinder head for this procedure.

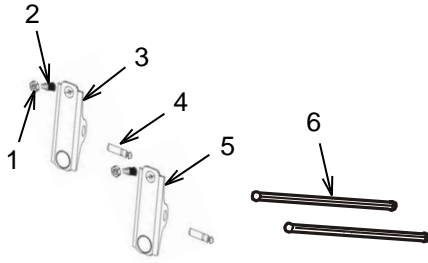

Remove locking nut (1) and adjusting nut (2). Remove pin (4), and remove exhaust valve rocker arm (3). Repeat the process for intake valve rocker arm (5). Check the rocker arms for wear. Replace if damaged. Remove pushrods (6). Inspect the pushrods. Make sure they are straight and not scored. Check the pushrods for wear. Replace the pushrods if worn or damaged.

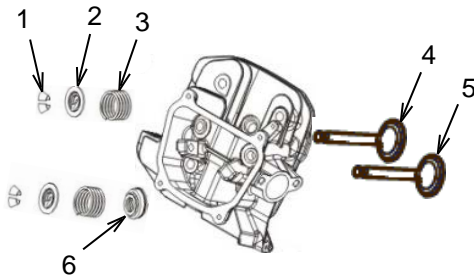

Note: Do not remove the retainers (2) while the head is still on the engine or the valves will drop down into the cylinder.

Remove valve rotators (1). Press down on retainer (2) and move it to the side so that the valve stem will pass through the larger hole. Remove valve spring (3) and exhaust valve (4). Repeat the process for the intake valve (5) and intake valve retainer (6).

Valve Springs:

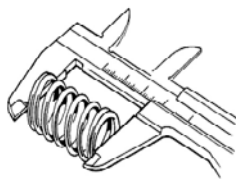

Check the free length of the valve spring. The normal free length is 34 mm. If the free length is 32.5 mm or less, replace the spring.

Valve Guides:

Inspect the valve guides. Make sure that they fit tightly into the cylinder head. Inspect the inner surfaces of the valve guides. The inner surface should be smooth, with no cracking or pitting. If the inner surface is damaged, replace the valve guide.

Valve Guides – Ream:

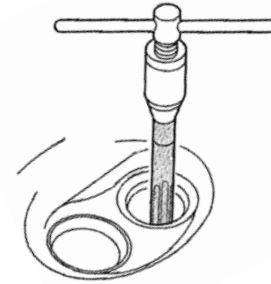

For best results perform this procedure when the valve guides and cylinder head are at room temperature.

Make sure that the reamer is centered over the valve guide. Coat the reamer and valve guide with cutting oil. Turn the reamer clockwise and work it through the valve guide for the entire length of the reamer. Continue to turn it clockwise as you remove the reamer from the valve guide. Remove any carbon deposits and check the internal diameter of the valve guide. The normal diameter of the valve guide is 5.5 mm. If the internal diameter of the valve guide is 5.572 mm or more, either replace the valve guide or install inserts.

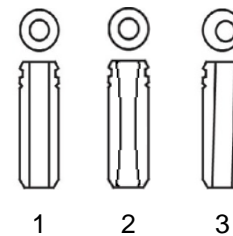

Check the valve guide bore. Insert the valve and make sure that it moves smoothly through the bore without any wobble. Figure 1 shows a good valve guide. Figure 2 shows a valve guide with abnormal wear that would allow the valve to wobble. The valve head could eventually break off and fall into the combustion chamber,

damaging the engine. This valve guide must be reamed or replaced. Figure 3 shows a valve guide with a bore that is not centered. This valve guide must be replaced.

Valve Guides – Replace:

Place the new valve guides in the freezer compartment of your refrigerator for one hour. Use a valve guide driver to drive out the old valve guides. Take care that you do not damage the cylinder head while driving out the old valve guides.

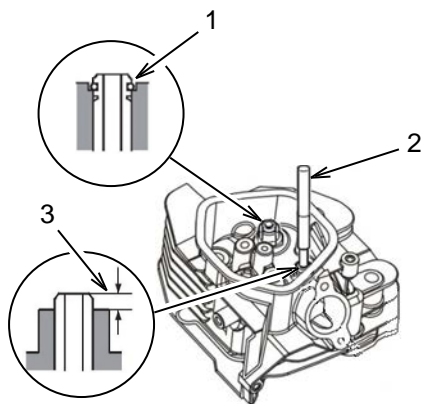

Install the new valve guides from the valve spring side of the cylinder head. Use the valve guide driver (2) to drive the exhaust valve guide in until the clip is fully seated (1). Drive the intake valve guide in until the top of the valve guide extends 1mm above the cylinder head (3). After installation check each valve guide for damage. If damaged, repeat the removal and installation process using a new valve guide.

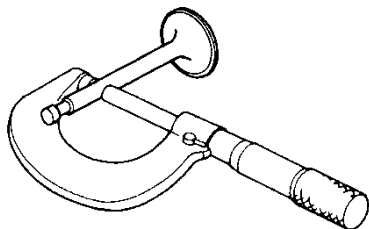

Use a micrometer to measure the outside diameter of the valve stem. Refer to the following table.

Valve:	Normal:	Minimum:
Intake:	5.48 mm	5.318 mm
Exhaust:	5.44 mm	5.275 mm

If the diameter of the valve is at or below the minimum, replace the valve.

Valves:

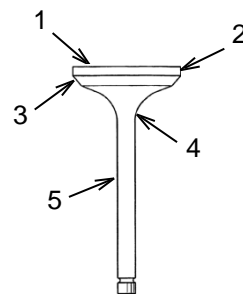

Check the valves for damage. Check the valve head (1), valve margin (2), and valve face (3) for damaged or burnt areas. Check the valve neck (4) for unusual wear. Check the valve stem (5) for wear, scoring, or bends. If any damage is found, replace the valve.

Remove any carbon deposits from the valve seats. Use a runout gauge to measure the concentricity of the seat. Alternatively, apply a light coat of a marking compound to the valve face and insert the valve into the head. Press the valve in firmly and then remove the valve. Check the paint for signs that the valve seat is not concentric. Remove the marking compound from both surfaces.

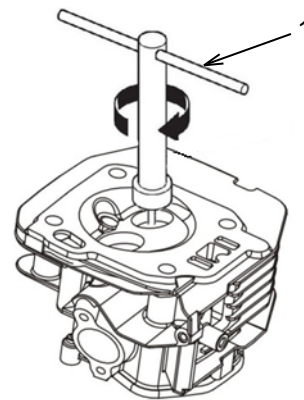

If the marking compound shows that the valve seat is not concentric, use a 45° valve seat cutter (1) to produce a smooth, concentric seat. Always turn the cutter clockwise. Use both the 45° valve seat cutter and the 32° valve seat cutter to adjust the valve seat so that it contacts the middle of the valve face. The 32° valve seat cutter removes material from the top of the seat. The 45° valve seat cutter removes material from the bottom of the seat. Be sure that when finished the area where the valve contacts the valve seat is from 0.8 mm to 2.0 mm wide. To

complete the procedure, make a light pass with the 45° valve seat cutter to remove any burrs that may be on the edge of the seat. When complete, use the marking compound to check for concentricity. Make sure that there is good contact all the way around the valve.

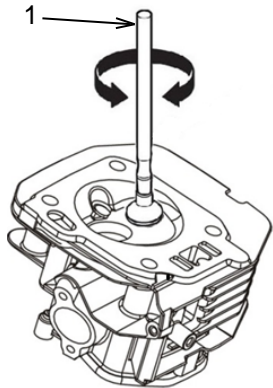

Apply lapping compound to the valve face and insert the valve into the cylinder head. Use a valve lapping tool (1) to finish surfacing the valve and valve seat. Remove any remaining compounds before assembling the cylinder head. Make sure that the pushrods are firmly seated in the lifters. After assembly, follow the Engine Valve Lash – Adjust and the Cylinder Pressure – Check procedures to ensure a proper assembly.

Engine Valve Lash – Adjust

Operating the engine with an improper valve adjustment can reduce engine efficiency. This reduced efficiency could result in excessive fuel usage and/or shortened engine component life.

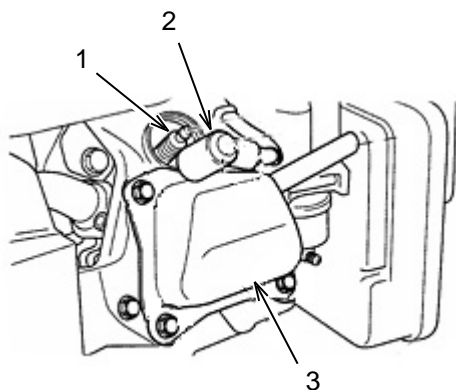

Remove spark plug cap (2), spark plug (1), valve cover (3), and valve cover gasket. Lightly pull the recoil starter until the piston is at top dead center.

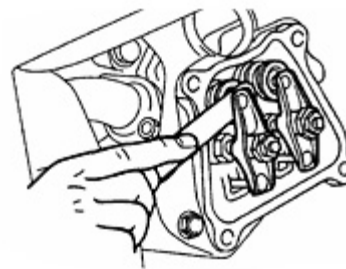

Measure the valve clearance with a feeler gauge. Refer to the following chart.

Valve Clearance	
Intake	0.05 ± 0.02mm
Exhaust	0.07 ± 0.02mm

If the clearance is outside of the tolerance range, adjust the clearance as follows:

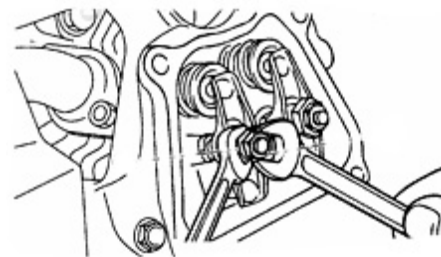

Loosen the locking nut. Turn the adjustment nut clockwise to decrease the gap. Turn the adjustment nut counterclockwise to increase the gap. When the valve clearance is within tolerance, tighten the locking nut to 8 ± 1 N·m. Reinstall the valve cover gasket and valve cover. Check the spark plug washer to ensure proper working condition. If the washer is damaged, replace the washer. Install the spark plug and tighten to 22 ± 2 N·m. DO NOT overtighten as this may damage the engine. Install the spark plug cap.

Flywheel - Install

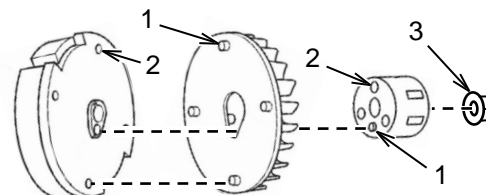

Align the positioning pins (1) on the starter cup and both sides of the impellor with the holes (2) in the starter cup and flywheel. Place the

assembly on the crankshaft. Secure the assembly to the crankshaft with nut (3). Tighten the nut to 95 ± 4 N·m.

Fuel Line and Filter – Replace

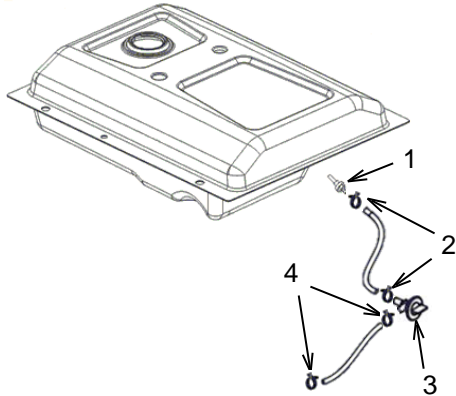

Drain the fuel from the fuel tank into an appropriate container. Dispose of any waste fuel using approved waste disposal services. Start the engine and let the engine run out of fuel. Turn the generator switch to the off "0" position.

Move clamps (2) to the center of the fuel line. Remove the fuel line from the fuel filter (1) and the fuel valve (3). Remove the fuel filter. Wipe the mounting surface with a clean rag and install a new fuel filter. Tighten the fuel filter to 3 - 4 N·m.

Move clamps (4) to the center of the fuel line. Remove the fuel line from the fuel valve and the carburetor.

Measure the lengths of the old fuel lines and cut new pieces of fuel line that are the same lengths. Inspect the clamps. If the clamps are damaged discard the old clamps and use new clamps. Place two clamps near the center of each new fuel line and install the fuel lines. Position the clamps so that they will hold the fuel line securely in place.

Fuel Tank Cap and Strainer – Clean

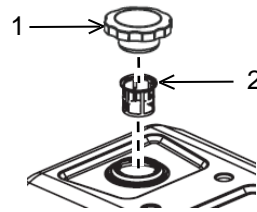

Wipe off the fuel cap (1) and surrounding area before removing the fuel cap. Wiping off the fuel cap and surrounding area before removing the fuel cap helps to reduce the amount of contaminants allowed into the fuel system.

Inspect the fuel cap. Make sure that the vent is not clogged. If plugged, use compressed air to clear the vent.

If there is a build-up of debris in the fuel strainer (2), remove the strainer and rinse out the strainer. Allow the strainer to dry before installing the strainer. If the strainer is damaged, replace the strainer.

Generator - Inspect

Once a month start the engine and run the engine until it reaches normal operating temperature (about 20 minutes). Plug in a corded device and turn on the device to ensure that the generator is providing power. Once you have verified that the generator is providing power, turn off the device and unplug it. Then turn the generator off.

Generator - Flash

Under certain conditions the generator can lose the residual magnetism that it needs for excitation. If this has occurred you may be able to charge the excitation field by following these steps:

1. Start the generator set
2. Plug a corded drill into one of the receptacles.
3. Press the trigger on the drill, rotate the chuck backwards and then immediately release the trigger.
4. Press the trigger on the drill to see if it works.

You may have to repeat Steps 3 and 4 a few times.

If the generator still does not provide power, refer to the Troubleshooting section in this manual.

Governor - Adjust

If the maximum engine speed cannot be brought into the proper range with the Engine Speed – Adjust procedure, the governor may need adjustment. You will need to remove the fuel tank and the control panel to adjust the governor.

Drain the fuel from the fuel tank into an appropriate container. Dispose of any waste fuel using approved waste disposal services. Start the engine and let the engine run out of fuel. Turn the generator switch to the off “0” position.

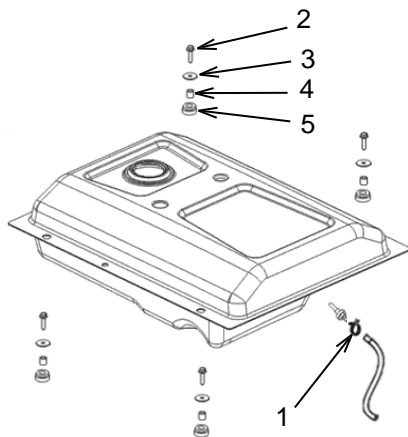

Remove hose clamp (1) and the fuel line from the fuel filter. Remove all four bolts (2), washers (3), bushings (4), and sleeves (5). Lift off the fuel tank.

Remove the control panel by following the instructions in Control Panel – Service.

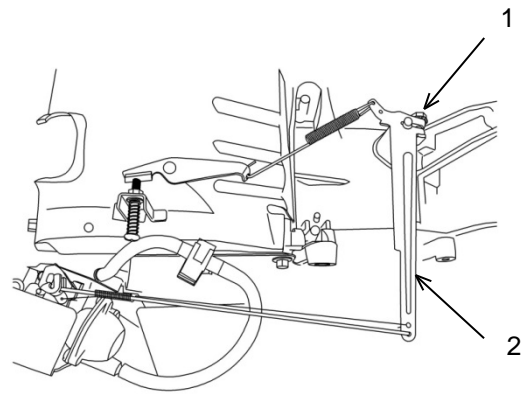

- Loosen nut (1)
- Make sure that the carburetor throttle valve is fully opened.
- Rotate governor arm shaft (2) fully to the right
- Tighten nut (1)
- Make sure that the governor arm and throttle valve move freely
- Reinstall the control panel
- Reinstall the gas tank.
- Start the engine and check the maximum engine speed.

If the speed is not within range, repeat the Engine Speed – Adjust procedure.

Ignition Coil – Test/Adjust

Drain the fuel from the fuel tank and the carburetor. Remove the fuel tank, air cleaner, carburetor, and recoil starter assembly.

Adjust the ignition coil:

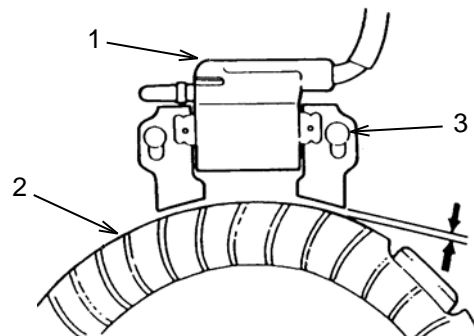

Use a feeler gauge to measure the clearance between the ignition coil (1) and the flywheel (2). The clearance should be 0.4 – 0.6 mm. If the clearance is out of the acceptable range, loosen screws (3) and move the coil so that the clearance is within range. Retighten the screws.

Test the primary side of the ignition coil:

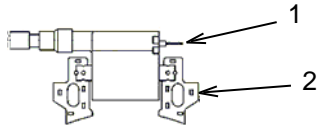

Measure the resistance of the primary coil by touching one lead of an Ohmmeter to the primary terminal (1) and touching the other lead to the metal frame (2). If the resistance is not in the 0.8 – 1.0Ω range, replace the coil.

Test the secondary side of the ignition coil:

Remove the spark plug cap from the spark plug wire, taking care to not damage the threads of the spark plug cap.

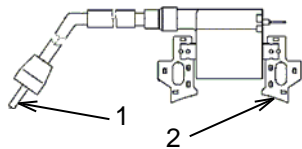

Measure the resistance of the secondary coil by touching one lead of an Ohmmeter to the spark plug wire (1) and touching the other lead to the metal frame (2). If the resistance is not in the 5.9 – 7.1kΩ range, replace the coil.

Measure the resistance of the sparkplug cap by touching one lead of an Ohmmeter to the wire end of the cap and the other lead to the spark plug end of the cap. If the resistance is not around 5kΩ, replace the spark plug cap.

Insulation - Test

Use a megohmmeter to check the insulation resistance of the stator winding in the following situations:

- The generator set is removed from storage.
- The generator set is operating in a humid environment.
- The generator set is not protected from the elements.
- The generator set has not been run under load for three months or more.

Winding to Ground:

Connect one of the megohmmeter's terminals to the winding being tested, and the other terminal to ground. When the reading stabilizes the value shown is the winding to ground insulation resistance value. The value should be very high.

If the value is not very high, or if the value has decreased significantly from the last reading, replace the generator.

Collector Ring to Ground:

Connect one of the megohmmeter's terminals to one of the copper rings on the collector, and the other terminal to the ground lug. When the reading stabilizes the value shown is the winding to ground insulation resistance value. The value should be very high. If the value is not very high, or if the value has decreased significantly from the last reading, replace the alternator.

Exhaust Silencer – Inspect/Replace

Allow the unit to cool before performing this procedure.

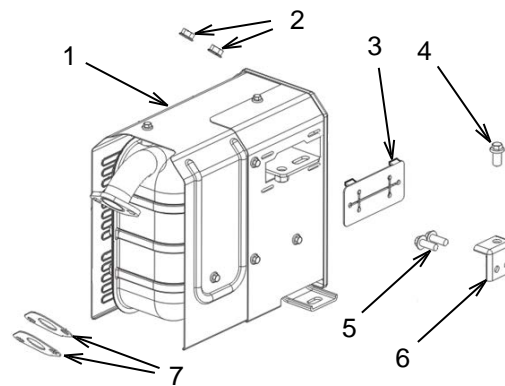

Remove nuts (2). Remove bolts (4) and (5) and remove bracket (6) and plate (3). Lift the exhaust silencer off of the mounting studs. Discard used gaskets (7). Removing the cover from the exhaust silencer is not recommended. Reinstall in reverse order using new gaskets (7). To service the screen, refer to Screen–Inspect/Clean/Replace.

Piston – Inspect/Replace

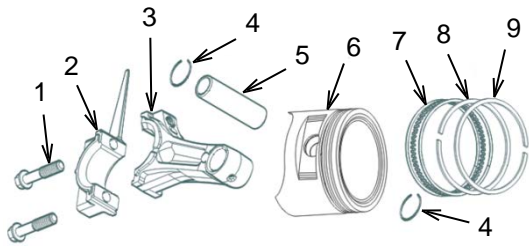

Remove the connecting rod bolts (1) and the rod cap (2). Push the connecting rod and piston out of the block. Remove any carbon deposits. Inspect the cylinder bore. If the cylinder wall is damaged, replace the crankcase. Use a ring puller to remove piston rings (7), (8), and (9). Inspect the rings. Replace if damaged or worn. Remove the piston pin clips (4) and piston pin (5). Measure the piston pin bore inside diameter. Measure the piston pin outside diameter. If the difference is 0.046 mm or more, replace the worn part. Inspect the top of the piston (6) for burns and cracks. Inspect the piston ring grooves for damage. If any damage or wear is found, replace the piston. Measure the piston skirt. The normal piston skirt diameter is 69.985 mm. If the skirt diameter is 69.975 mm or less, replace the piston. Set the piston into the cylinder and measure the clearance between the piston and the cylinder wall by inserting a feeler gauge. If the clearance is 0.12 mm or more, replace the piston.

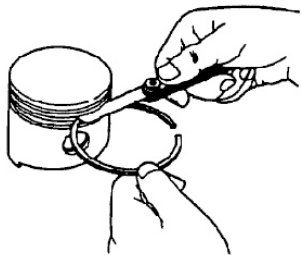

Measure the ring clearance, as shown. Normal clearance is between 0.015 and 0.045 mm. If the clearance is 0.15 mm or more, replace the piston.

Install the oil ring onto the piston and insert the piston into the cylinder. Measure the end gap of the oil ring. The normal end gap for the oil ring is between 0.15 and 0.35 mm. If the end gap is 1mm or more, replace the oil ring. If the end gap is less than 0.15 mm, use a fine file to increase the gap. Take care not to leave any sharp edges.

Install the second ring onto the piston and insert the piston into the cylinder. Measure the end gap of the ring. The normal end gap for the ring is between 0.20 and 0.40 mm. If the end gap is 1mm or more, replace the oil ring. If the end gap is less than 0.20 mm, use a fine file to increase the gap. Take care not to leave any sharp edges. Repeat this procedure for the top ring. The measurements for the top ring are the same as the second ring.

Connecting Rod:

Check the connecting rod. If the connecting rod is bent or cracked, replace the connecting rod. Measure the pin end inside diameter. A normal diameter is 18.006 mm. If the diameter is 18.017 mm or more, replace the connecting rod. Install the rod cap and measure the inside diameter of the crank end of the connecting rod. A normal diameter is 30.215 mm. If the diameter is 30.225 mm or more, replace the connecting rod.

Installation:

The piston head has a triangular mark to aid in assembly.

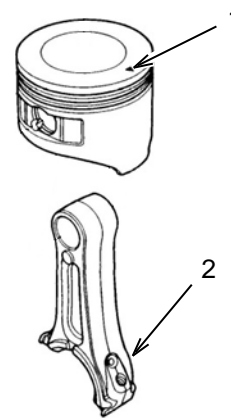

Place the connecting rod into the piston so that the longer side of the rod (2) is aligned with the mark on the piston head (1). Insert the piston pin through one side of the piston, through the connecting rod, and then through the other side of the piston.

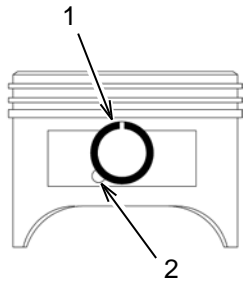

Install the piston pin clip (1) into the groove in the side of the piston. Use long nosed pliers to rotate the clip in. Do not align the gap with the cutout (2). Repeat for the other side.

Rings:

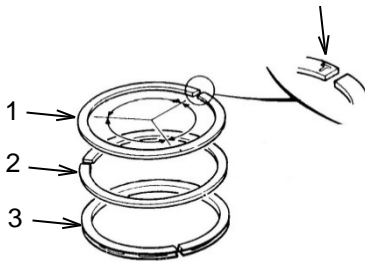

The piston rings have a mark next to the gap. Use a ring puller to install the rings with the mark facing toward the top of the piston. Make sure that you install the rings in the proper grooves, with the oil ring (3) in the lowest groove, the second ring (2) in the middle groove, and the top ring (1) in the groove closest to the head of the piston. The top ring is chrome plated. Make sure that the rings will move freely in the ring groove. Install the rings with the gaps 120° apart, as shown in the drawing.

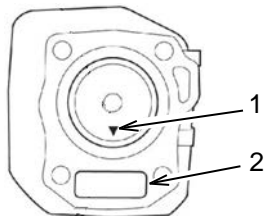

Coat the piston, rings, and cylinder wall with engine oil. Use a ring compressor to push in the rings and insert the piston into the cylinder. Make sure that the mark on the piston head (1) aligns with the lifter mark (2) on the crankcase. Use a piston driver to push the piston out of the ring compressor and into the cylinder.

Install the rod caps and rod cap bolts. Tighten the bolts to 15±1 N·m.

Recoil Starter Spring - Install

Note: It is recommended that you replace the entire recoil starter assembly.

Inspect the parts. Replace any parts that are damaged or worn.

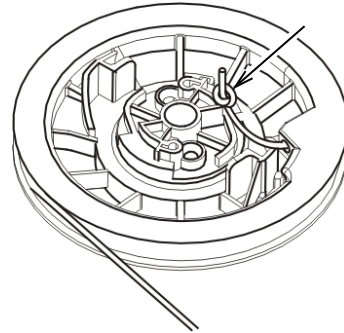

Pass the recoil starter cord through the hole in the recoil starter pulley and make a knot at the rope end as shown above.

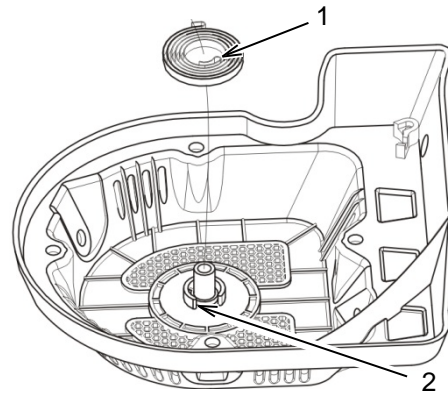

Place the inside hook (1) of the recoil starter spring in the groove (2) of the recoil starter case and set the recoil starter spring into the case. Hold the spring in place.

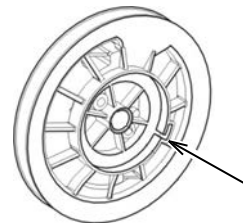

Place the outside hook of the recoil starter spring in the groove of the recoil starter pulley and hold the pulley in place.

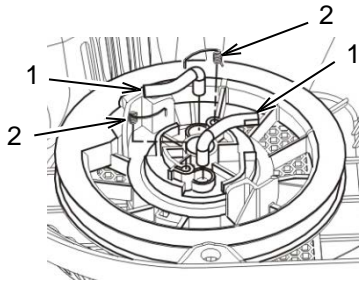

Set the starter drive cams (1) on the recoil starter pulley, and install the return springs (2) on the pulley and hook them on the side of the drive cams.

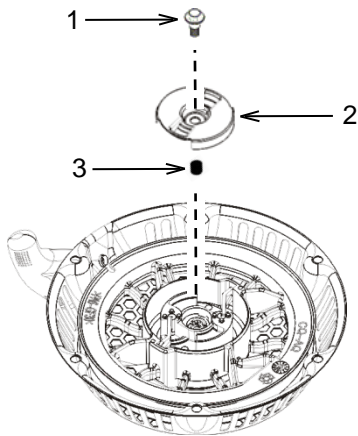

Install spring (3), drive guide (2), and fixing screw (1). Tighten the fixing screw to 9 ± 1 N·m.

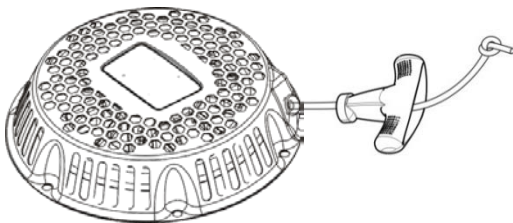

Wrap the cord around the pulley. Pull lightly on the cord and push the end of the cord through the housing. Then push the end of the cord through the handle. Tie a knot in the end of the cord and let the spring pull the handle back to the housing. Pull lightly to make sure that the assembly is working properly.

Spark – Check

⚠ DANGER

Shock/Electrocution Hazard: Do not operate this equipment or work on this equipment unless you have read and understand the instructions and warnings in the Owner's Manual. Failure to follow the instructions or heed the warnings will result in serious injury or death.

Make sure that your hands are dry and that you are not electrically grounded.

To reduce the risk of a flash fire, make sure that there is no open fuel in the vicinity. Turn the fuel valve to the off "0" position, and drain the fuel out of the carburetor.

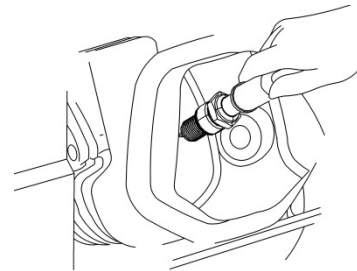

- Remove the spark plug cap and spark plug
- Pull the recoil starter handle to drain the fuel from the cylinder
- Install the spark plug cap onto the spark plug
- Turn the generator switch to the on "I" position.
- Hold the spark plug by the spark plug cap and gently place the threads of the spark plug against the cylinder head as shown above.
- Pull the recoil starter handle and check for a spark.
- If the spark is weak or if there is no spark, refer to Spark Plug – Inspect/Adjust/Replace.
- If the spark is not the problem, refer to Ignition Coil – Inspect.

Screen - Inspect/Clean/Replace

This unit has a screen fitted to the exhaust outlet of the silencer. The screen should be cleaned with a soft wire brush after every 50 hours or 3 months of use. The screen should be replaced

after every 100 hours of operation or if it becomes damaged.

Hot Surface



! WARNING

Hot parts or hot components can cause burns or personal injury. Do not allow hot parts or components to contact your skin. Use protective clothing or protective equipment to protect your skin.

DO NOT perform this maintenance procedure until the exhaust silencer has cooled.

Remove the screws that hold the screen to the silencer. Remove the screen. Check the screen. Carefully clean the screen with a soft wire brush. If the screen is damaged, replace the screen.

To install the screen, align the mounting holes in the screen with the mounting holes on the silencer. Insert the screws and tighten securely.

Spark Plug – Inspect/Adjust/Replace

Refer to the Specifications section of this manual to determine the proper spark plug part number and spark plug gap for your product.

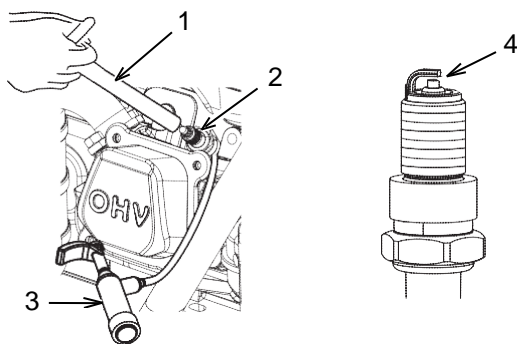

1. Remove the side panel.
2. Remove the spark plug cap (3)
3. Use the plug wrench (1) or a ratchet and a spark plug socket to remove the spark plug (2).
4. Visually check the spark plug to see if

it is damaged. If the insulator is cracked, replace the spark plug. If the electrode is damaged, replace the spark plug.

5. Measure the plug gap (4) with a feeler gauge. The gap should be from 0.7 mm - 0.8 mm. Adjust the gap as necessary by carefully bending the side electrode. if needed.
6. Check the spark plug washer to ensure proper working condition. If the washer is damaged, replace the washer.
7. Install spark plug and tighten to 22 ± 2 N·m. DO NOT overtighten as this may damage the engine.
8. Install the spark plug cap.

Timing Gear – Inspect/Replace

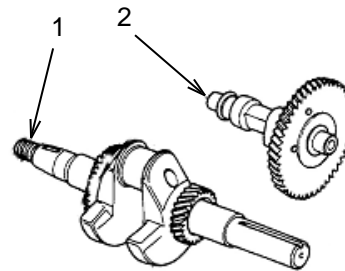

Inspect the gears on and the crankshaft (1) and the camshaft (2). If the gears are worn or any teeth are broken, replace the gear. Check the engagement of the gears. If the gears fit together too loosely the engine will run louder than normal. It is recommended that you replace the gears if the engagement is loose. If you must replace the gears or shafts, replacing them one at a time will lessen the chance of assembling them incorrectly.

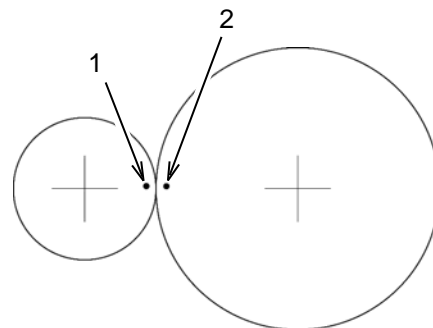

The crankshaft and cam shaft both have alignment marks on the gear face. Use these marks to align the gears during assembly. When

aligning the marks, make sure that the piston is at the top dead center position.

Voltage Regulator – Replace

The voltage regulator is located behind the cover of the generator.

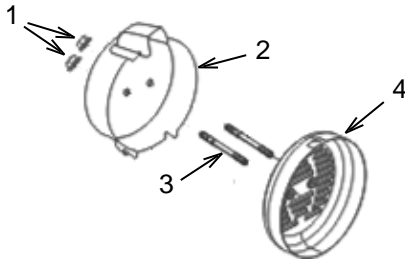

Remove nuts (1) and remove outer cover (2). Slide cover (4) off studs (3).

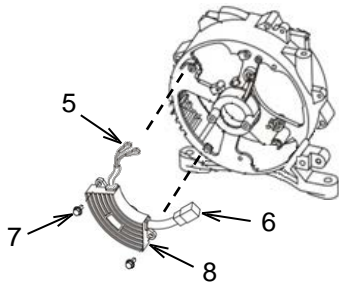

Disconnect leads (5) from the brush and unplug connector (6). Remove bolts (7) and voltage regulator (8). Reinstall in reverse order. The red lead goes onto the “+” terminal of the brush. The white lead goes onto the “-” terminal of the brush.

Walk-Around Inspection

Before starting the engine perform a visual inspection of the unit. Look for:

- Proper oil level
- Proper fuel level
- Good quality fuel
- Fluid leaks
- Loose clamps
- Loose bolts
- Cracked fuel line
- Loose or frayed wiring
- Built up debris

In addition, make sure that:

- The ground strap is properly connected
- The circuit breakers are in the off “0”

position

- The choke knob is in the proper position.
- The fuel switch is in the on “I” position

Windings – Test

Field Winding:

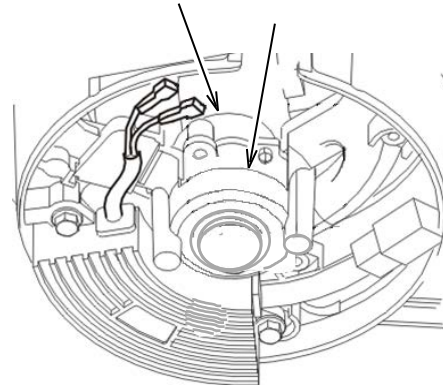

Remove the brush. Use an Ohmmeter or multimeter to measure the resistance of the collector ring at the points shown. The resistance should be $58.5 \Omega \pm 10\%$ at 25°C . If the resistance is out of tolerance, clean the collector ring and retest. Replace the generator if necessary.

Main Winding:

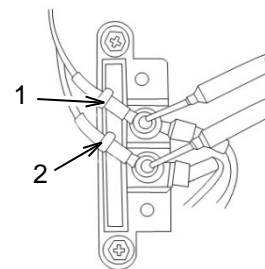

On the terminal block, use an Ohmmeter or multimeter to measure the resistance of the main winding. Place the meter across the white wire (1) and the brown wire (2). The resistance should be $0.35 \Omega \pm 10\%$ at 25°C . If the resistance is out of tolerance, replace the generator. Measure the resistance from the wires to the ground lug. The resistance should be infinite. If the resistance is not infinite, replace the generator.

STORAGE

When a generator is in storage, moisture may condense in the windings. In order to minimize condensation, always store the generator in a dry area. Cover the generator with a protective cover that extends to the ground. The cover should remain loose around the generator in order to allow proper ventilation.

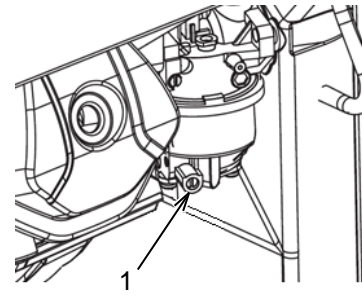

Storage for 1 – 3 months

Remove any dirt, rust, grease, and oil from the generator. DO NOT use a pressure washer to clean the generator. Inspect the exterior. Make any necessary repairs.

Add fuel stabilizer to the fuel tank to prevent the gasoline from going bad. Start and run the engine for 10 minutes to ensure that the fuel stabilizer has been pulled in to the carburetor. Shut off the engine and allow the engine to cool.

Turn the fuel valve to the off “0” position.

Move the generator to the storage place. Cover the generator.

Storage for more than 3 months

Remove any dirt, rust, grease, and oil from the generator. DO NOT use a pressure washer to clean the generator. Inspect the exterior. Make any necessary repairs.



No Open Flames

DANGER

Gasoline is extremely flammable and is explosive under certain conditions. Drain the fuel in a well-ventilated area with the engine stopped and cool. Never smoke or allow flames or sparks in the area during this procedure.

Note: Only use fuel containers that comply with the relevant United Nations Economic Commission for Europe (“UNECE”) specifications and are marked with the UN number for petrol (UN1203). Dispose of any waste fuel using approved waste disposal services.

Make sure that the fuel valve is in the on “1” position. Remove the fuel cap and the drain plug (1) from the carburetor bowl and drain the fuel into a suitable container. DO NOT save the fuel for future use in the generator. Once the fuel has completely drained from the system install the drain plug into the carburetor. Turn the fuel valve to the off “0” position. Apply a small amount of oil to the threads on the fuel tank filler neck and install the cap.

Change the engine oil.

Remove the spark plug and pour a small amount of oil into the cylinder. Install the spark plug but do not install the spark plug cap. Pull the starter handle 3 times to distribute the oil over the cylinder walls.

Move the generator to the storage place. Cover the generator.

DIAGRAMS

Air Filter Assembly

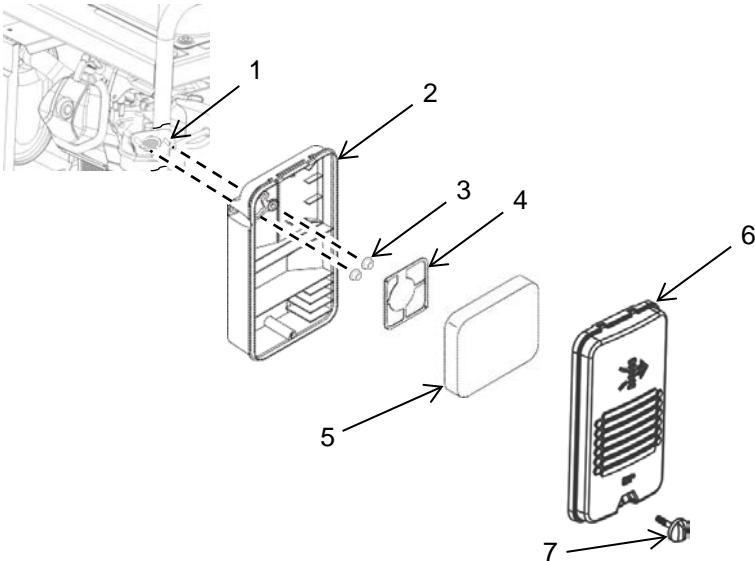

- 1. Mounting studs
- 2. Housing
- 3. Nut 6mm
- 4. Support

- 5. Filter element
- 6. Cover
- 7. Cover bolt

Carburetor

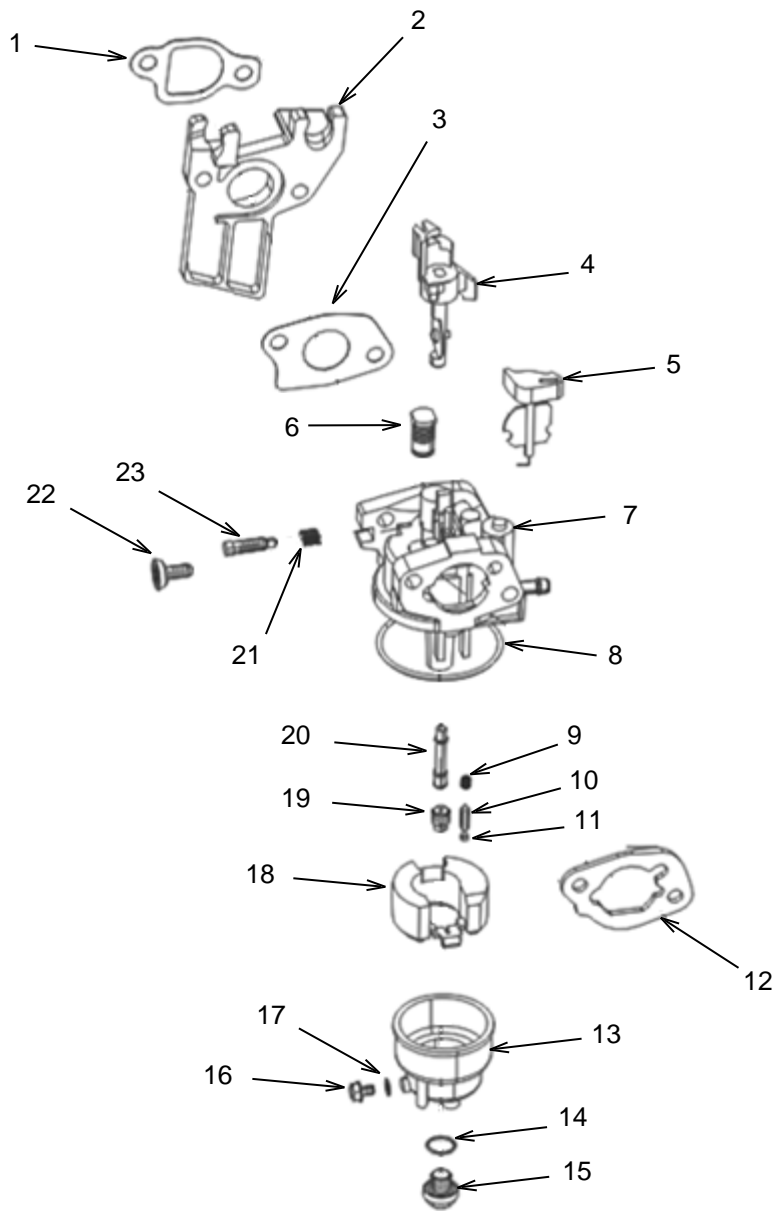

- 1. Isolator / head gasket
- 2. Isolator
- 3. Carburetor / isolator gasket
- 4. Throttle shaft
- 5. Choke Shaft
- 6. Pilot jet
- 7. Carburetor body
- 8. Gasket

- 9. Float valve
- 10. Float spring
- 11. Washer
- 12. Air filter / carburetor gasket
- 13. Float chamber
- 14. Gasket
- 15. Bolt
- 16. Drain bolt

- 17. Gasket
- 18. Float
- 19. Main jet
- 20. Nozzle
- 21. Spring
- 22. Pilot screw
- 23. Pilot valve

Control Panel

European Union

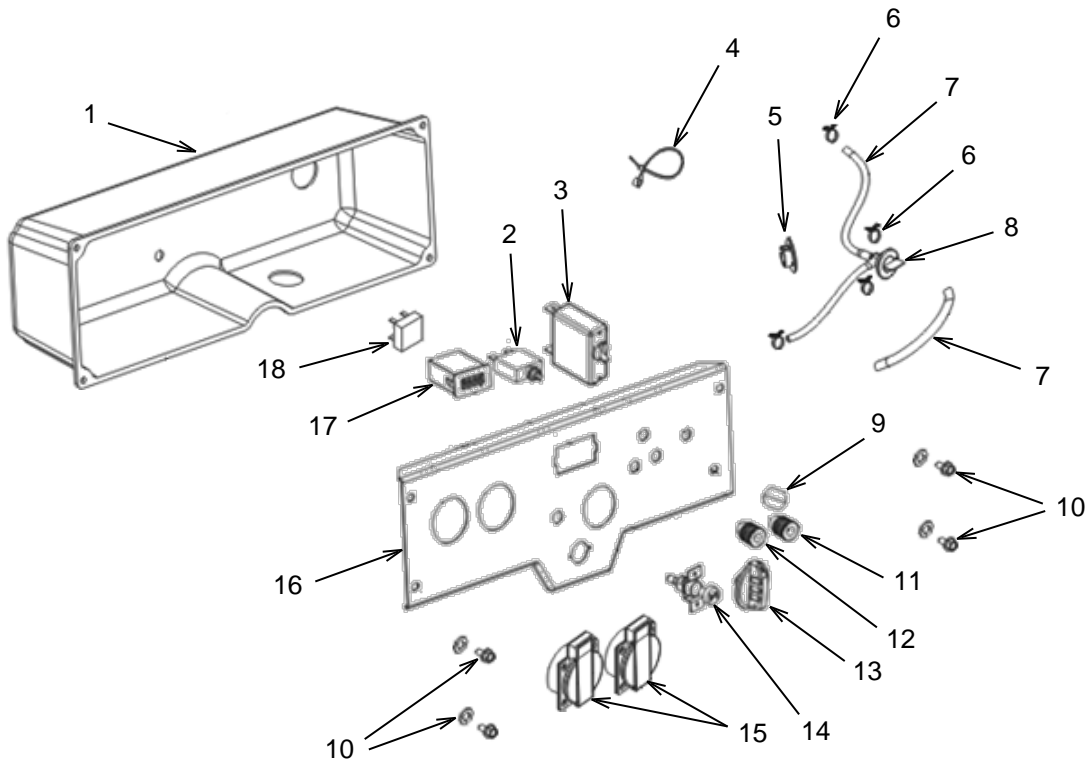

- | | |
|--------------------------|--------------------------|
| 1. Housing | 10. Bolt and washer |
| 2. Overcurrent protector | 11. Negative DC terminal |
| 3. Circuit breaker | 12. Positive DC terminal |
| 4. Cable tie | 13. Generator switch |
| 5. Fuel valve clip | 14. Choke |
| 6. Hose clamp | 15. 230VAC receptacle |
| 7. Fuel line | 16. Panel |
| 8. Fuel valve | 17. Display |
| 9. Panel light | 18. Rectifier |

Control Panel
United Kingdom

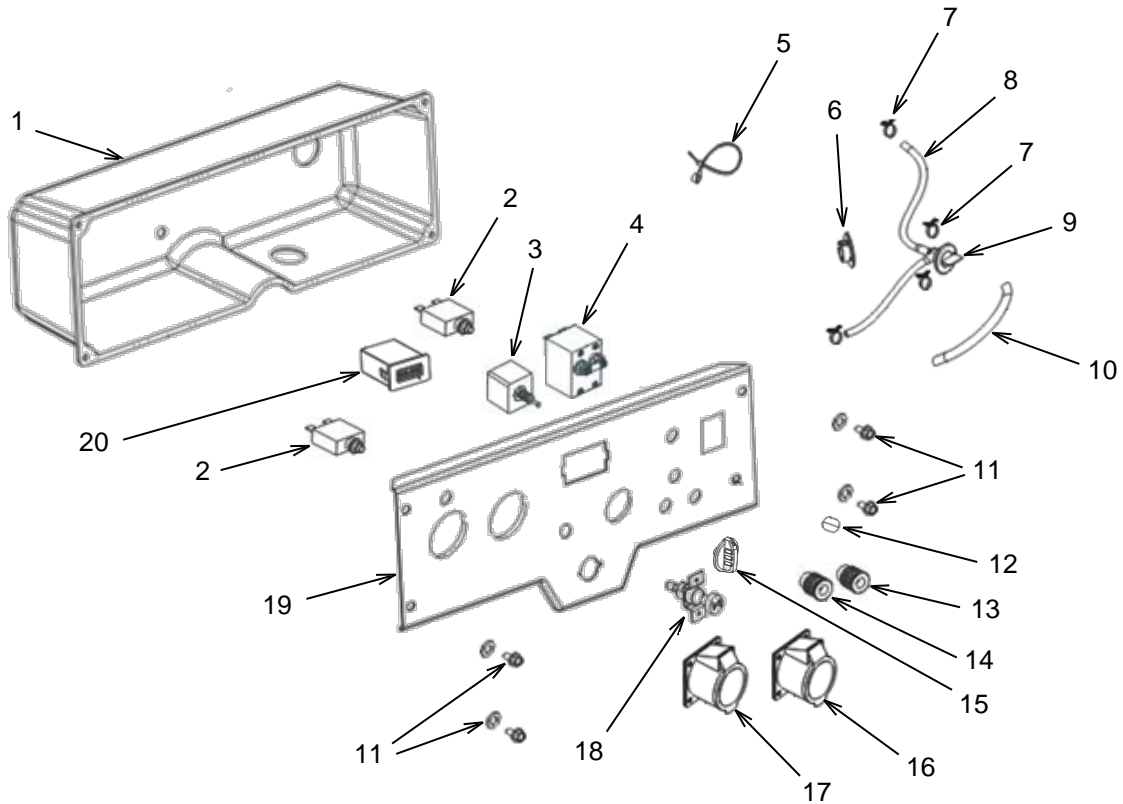

- | | |
|--------------------------------|--------------------------|
| 1. Housing | 11. Bolt and washer |
| 2. Overcurrent protector | 12. Panel light |
| 3. Voltage selector switch | 13. Negative DC terminal |
| 4. Double pole circuit breaker | 14. Positive DC terminal |
| 5. Cable tie | 15. Generator switch |
| 6. Fuel valve clip | 16. 230VAC receptacle |
| 7. Hose clamp | 17. 115VAC receptacle |
| 8. Fuel line | 18. Choke |
| 9. Fuel valve | 19. Panel |
| 10. Cover | 20. Display |

Crankcase and Piston

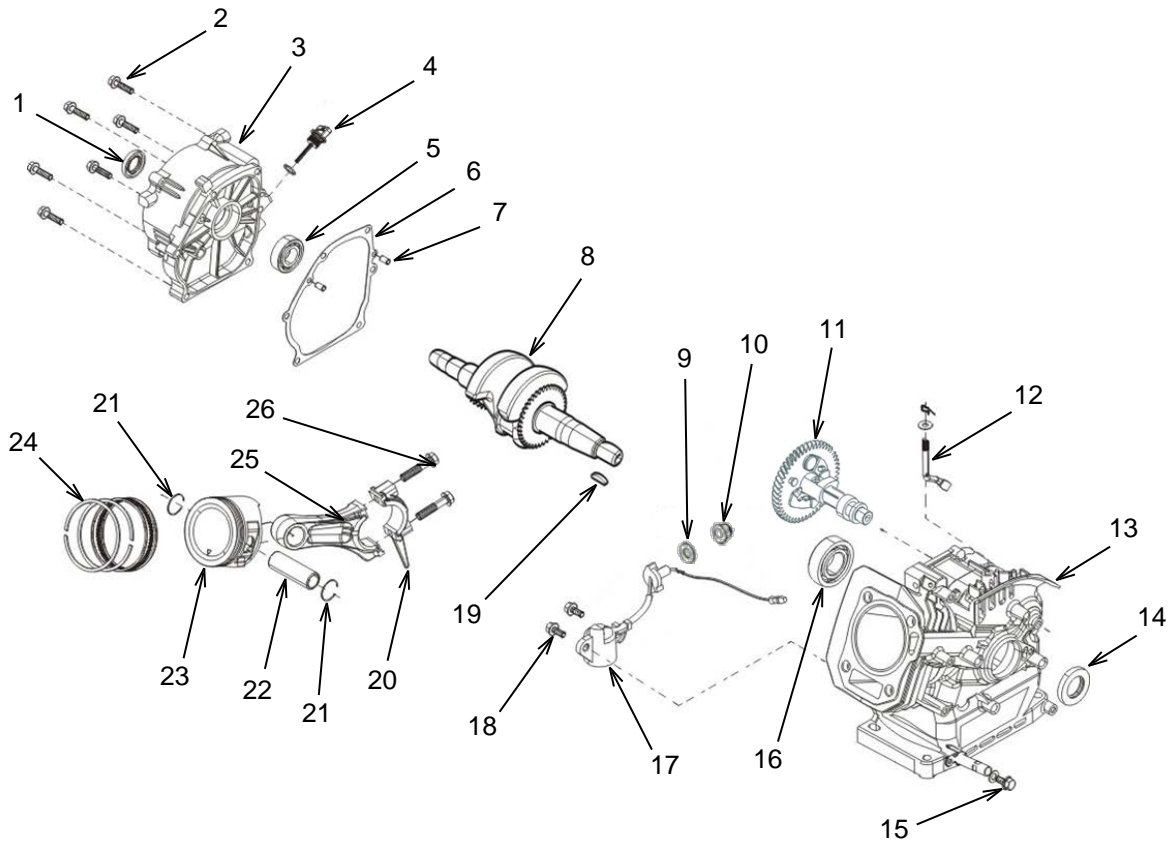

- | | |
|---------------------------|---------------------|
| 1. Seal | 14. Seal |
| 2. Bolt (M8x35mm) | 15. Oil drain |
| 3. Crankcase cover | 16. Bearing |
| 4. Oil gauge and seal | 17. Oil sensor |
| 5. Bearing | 18. Bolt (M6x14mm) |
| 6. Crankcase gasket | 19. Key |
| 7. Pin | 20. Rod cap |
| 8. Crankshaft | 21. Piston pin clip |
| 9. Washer | 22. Piston pin |
| 10. Nut (M9) | 23. Piston |
| 11. Camshaft | 24. Piston rings |
| 12. Governor arm assembly | 25. Connecting rod |
| 13. Crankcase | 26. Bolt (M7x32mm) |

Cylinder Head and Valves

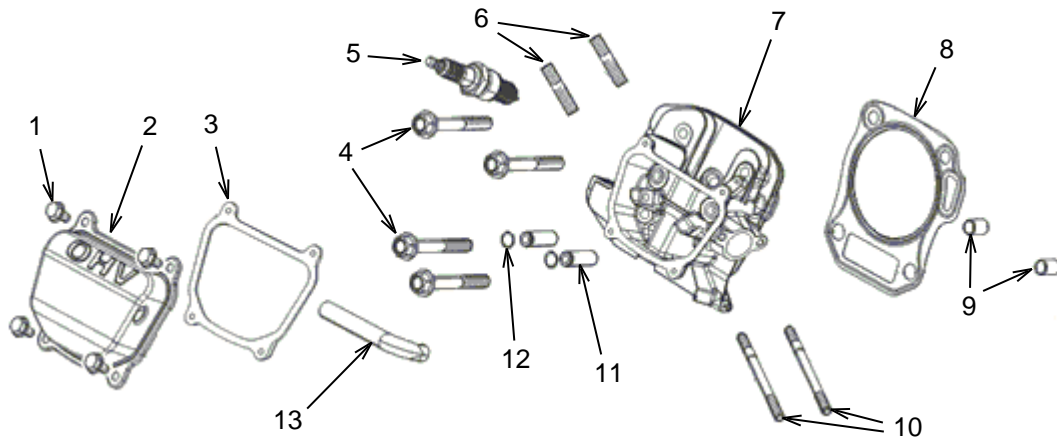

- | | | |
|------------------------|-------------------------|-------------------|
| 1. Valve cover bolt | 6. Stud (8x34mm) | 11. Valve guide |
| 2. Valve cover | 7. Cylinder head | 12. Clip |
| 3. Valve cover gasket | 8. Cylinder head gasket | 13. Breather tube |
| 4. Cylinder head bolts | 9. Pin | |
| 5. Spark plug | 10. Stud (9x112mm) | |

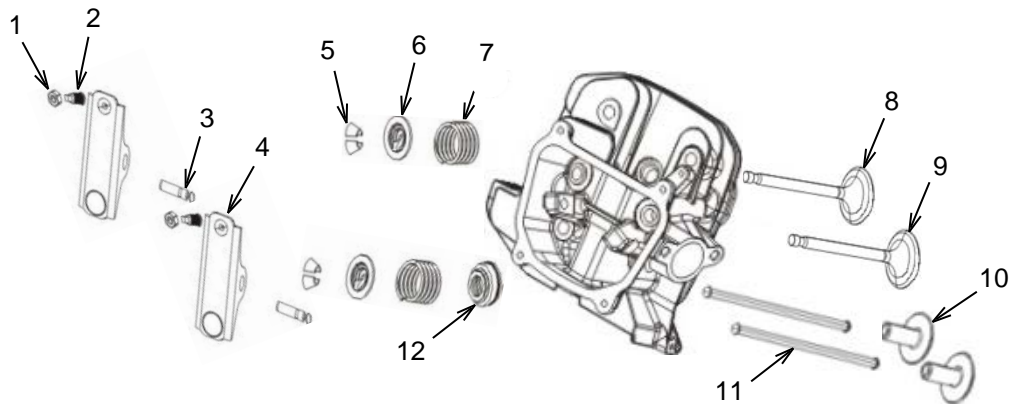

- | | |
|-------------------|------------------|
| 1. Locking nut | 7. Spring |
| 2. Adjusting nut | 8. Exhaust valve |
| 3. Rocker arm pin | 9. Intake valve |
| 4. Rocker arm | 10. Lifter |
| 5. Valve rotator | 11. Push rod |
| 6. Retainer | 12. Retainer |

Flywheel

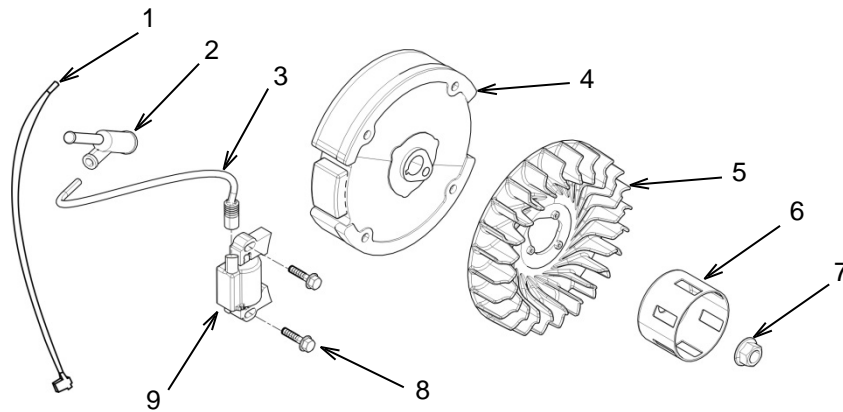

1. Tie wrap
2. Spark plug cap
3. Spark plug wire
4. Flywheel
5. Impeller

6. Starting cup
7. Nut (16mm)
8. Bolt (6x25mm)
9. Ignition coil

Fuel Tank

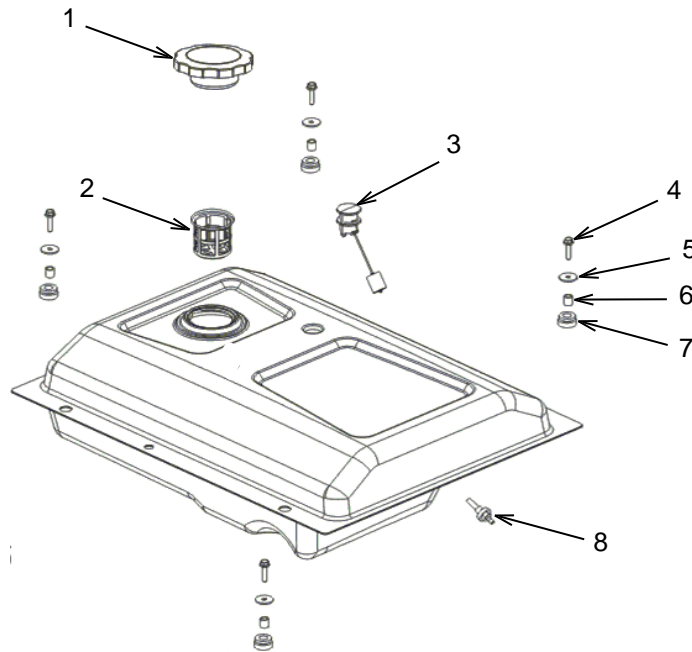

1. Fuel cap
2. Fuel strainer
3. Fuel gauge
4. Bolt (32x14mm)

5. Washer
6. Bushing
7. Sleeve
8. Fuel filter

Alternator

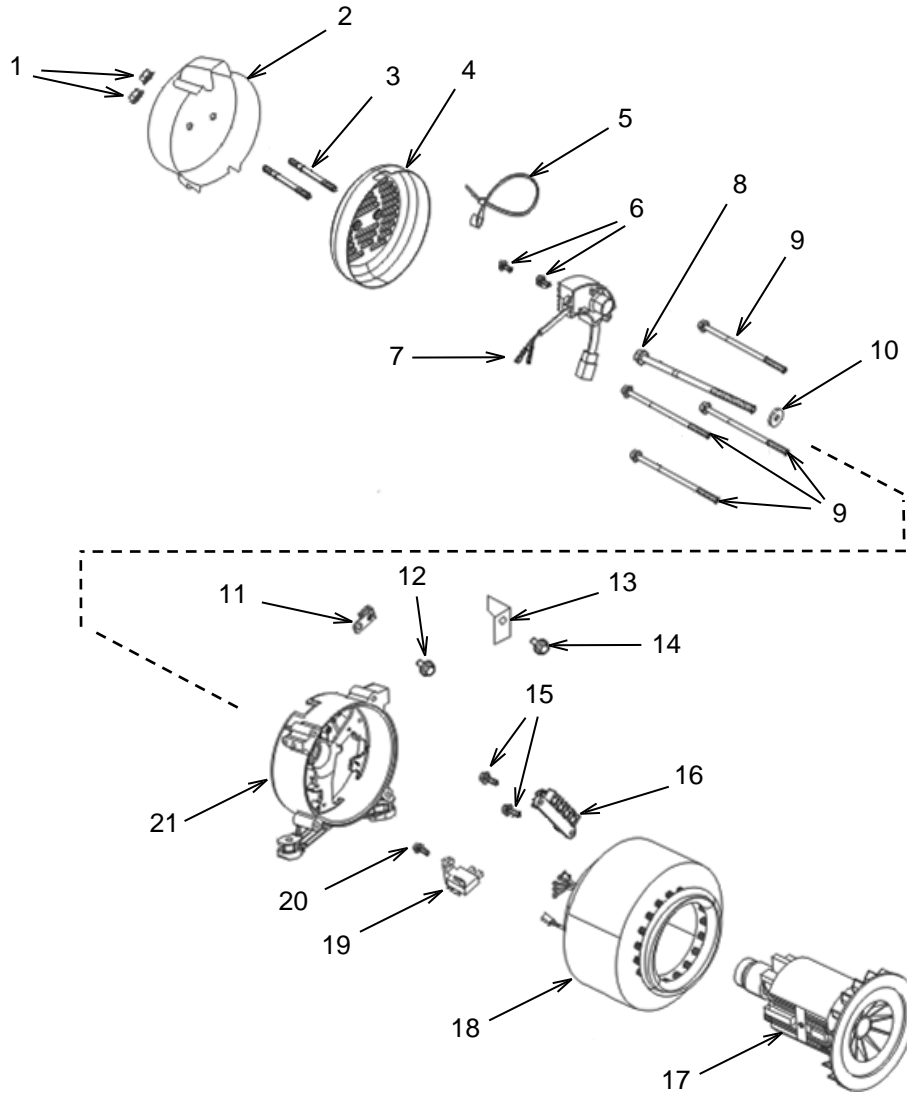

- | | | |
|----------------------|------------------------|--------------------|
| 1. Nut | 8. Bolt (287x20mm) | 15. Bolt |
| 2. Outer cover | 9. Bolt (195x13mm) | 16. Terminal block |
| 3. Stud | 10. Washer (33mm) | 17. Rotor |
| 4. Inner cover | 11. Grounding terminal | 18. Stator |
| 5. Cable tie | 12. Bolt | 19. Brush assembly |
| 6. Bolt | 13. Stopper | 20. Bolt |
| 7. Voltage regulator | 14. Bolt | 21. Bracket |

Exhaust Silencer

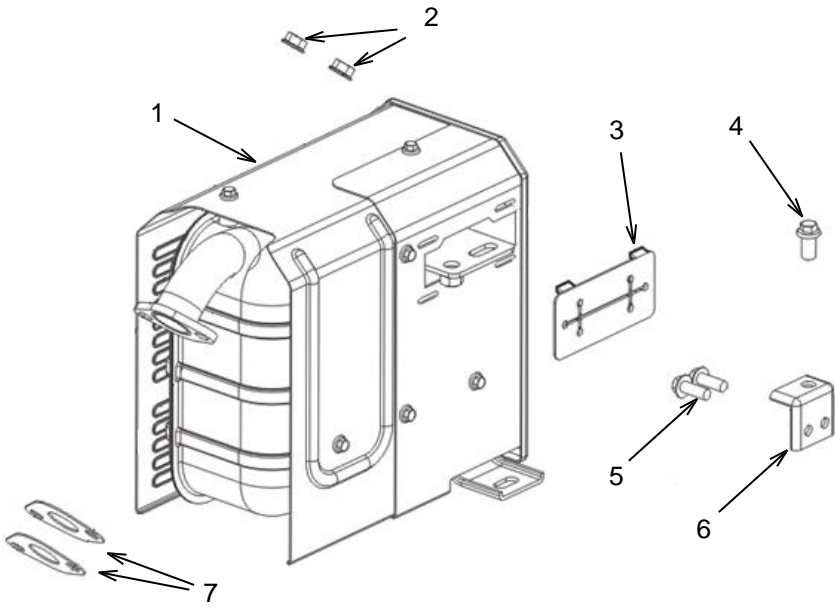

1. Exhaust silencer assembly
2. Nut (M13)

3. Plate
4. Bolt (M18x24mm)
5. Bolt (M13x19mm)

6. Bracket
7. Gasket

Recoil Starter

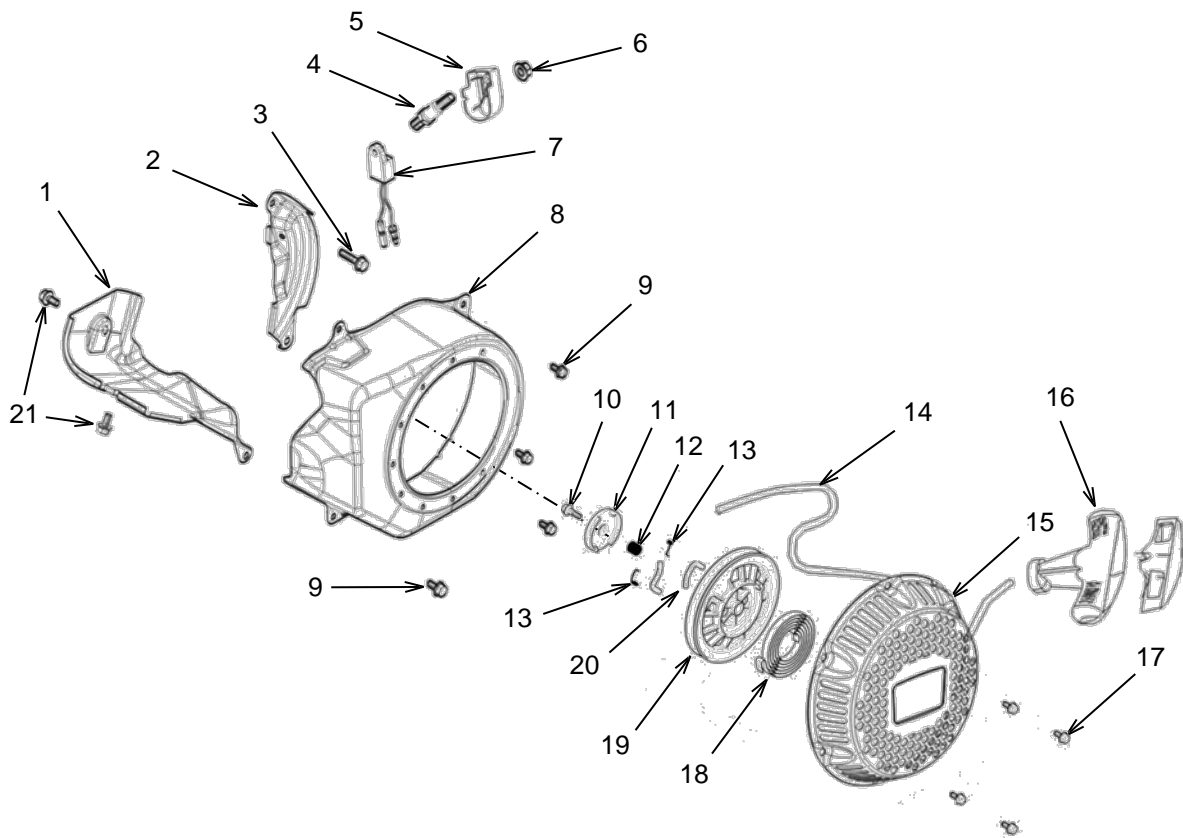

- 1. Cylinder body shroud
- 2. Lower shield
- 3. Bolt
- 4. Protector cover bolt
- 5. Protector cover
- 6. Nut
- 7. Oil protector

- 8. Housing
- 9. Bolt
- 10. Locking screw
- 11. Drive guide
- 12. Spring
- 13. Return spring
- 14. Cord

- 15. Housing
- 16. Handle assembly
- 17. Bolt 6x12mm
- 18. Starter Spring
- 19. Recoil starter pulley
- 20. Drive cams
- 21. Bolt 6x12mm

TROUBLESHOOTING

Issue:	Possible Cause:	Solution:	Check:
Engine Will Not Start	Generator switch in the off "0" position	Turn the generator switch to the correct position.	Start the engine
	Choke knob in the wrong position	Place the choke knob in the correct position.	
	Not enough oil in the engine	Check the oil level. If low, add the recommended oil. Refer to Engine Oil Level – Check for the proper oil.	
	Dirty air filter	Check the air filter. Clean or replace as needed.	
	No fuel	Fill the fuel tank	
	Old or contaminated fuel	Drain and refill if necessary.	
	No fuel at the carburetor	Make sure the fuel switch is in the on "I" position.	
		Check the vent in the fuel cap. If vent is plugged clean the vent.	
	Not enough fuel to the engine	Make sure the needle valve is closing properly. Clean or replace as needed.	
		Inspect the fuel nozzle. Clean if needed.	
		Inspect the float. If the float is damaged or sticking, repair or replace as needed.	
	Engine flooded	Wait 5 minutes.	
		Remove and clean the spark plug. Suction out fuel or let fuel evaporate before reinstalling spark plug.	
	No spark	Inspect the spark plug. Clean the spark plug, adjust the spark plug gap, or replace the spark plug as necessary.	
		Inspect the spark plug wire. Replace if damaged. Check the resistance. If the resistance is out of tolerance, replace the wire.	
		Inspect the ignition coil. Replace if damaged. Check the resistances. If any of the resistances are out of tolerance, replace the ignition coil.	
		Inspect the gap between the ignition coil and flywheel. Adjust gap if necessary.	
		Inspect the magneto. Replace if needed.	
		Check the wiring to make sure that none of the wires are shorted to ground.	
	Cylinder pressure	Inspect the cylinder head bolts to make sure they are properly torqued to 40±3 N·m (30±2 lb ft). Tighten if needed.	
Check the valve clearance and seats. Adjust or repair as needed.			
Inspect the cylinder head gasket. Replace if damaged.			
Inspect the cylinder head and cylinder block surfaces for flatness. Repair or replace if out of tolerance.			
Inspect the piston rings. If the piston rings are worn or broken, replace the piston rings.			
If the engine still will not start:	Rebuild the engine, replace the engine, or consider replacing the unit.		

Issue:	Possible Cause:	Solution:	Check:
Engine Starts But Runs Rough or Does Not Have Enough Power	Dirty air filter	Check the air filter. Clean or replace as needed	Start the engine. Check if it has power or runs rough
	Choke knob in the wrong position	Place the choke knob in the correct position.	
	Air in fuel line or fuel line clogged	Check the fuel line. Clear or replace as needed.	
	Not enough fuel to the engine	Make sure the needle valve is closing properly. Clean or replace as needed.	
		Inspect the fuel nozzle. Clean if needed.	
		Inspect the float. If the float is damaged or sticking, repair or replace as needed.	
	Carbon built up in combustion chamber	Remove the cylinder head and clean if needed.	
	Cylinder pressure	Check the valve clearance and seats. Refer to the Maintenance Specifications chart and the Engine Valve Lash – Adjust article for the proper value. Adjust or repair as needed.	
		Inspect the cylinder head gasket. Replace if damaged.	
Inspect the piston rings. If the piston rings are worn or broken, replace the piston rings.			
If the engine still has low power:	Rebuild the engine, replace the engine, or consider replacing the unit.		
Engine Shuts Down	Out of fuel	Check the fuel level. Fill the tank if necessary.	Start the engine. Check if it shuts down
	Not enough oil in the engine	Check the oil level. If low, add the recommended oil. Refer to the Engine Oil Level-Check article for the proper oil to use.	
	Dirty air filter	Clean the air filter.	
	Generator overloaded	Unplug some of the devices.	
	If the engine still shuts down:	Rebuild the engine, replace the engine, or consider replacing the unit.	
Engine Making Unusual Sound	Knocking	Check the engine temperature. If the engine is running too hot, refer to the section on overheating.	Start the engine. Check for unusual sound
		Make sure the fuel is good and the proper rating. Drain and refill the fuel tank if necessary.	
		Make sure the flywheel is properly tightened to the crankshaft. Refer to Flywheel – Install for the proper torque.	
		Check the valve clearance. Refer to the Maintenance Specifications chart and the Engine Valve Lash – Adjust article for the proper value. Adjust the valve clearance if it is out of tolerance.	
		Check for carbon deposits in the cylinder. Clean if needed.	
		Inspect the piston and piston rings. If the piston or rings are worn or broken, replace the defective part.	
		Inspect the piston pin and piston pin hole. Replace if worn.	
		Inspect the connecting rod ends. Replace if worn.	
	Inspect the main bearing. Replace if worn.		
If the engine still makes an unusual sound:	Rebuild the engine, replace the engine, or consider replacing the unit		

Issue:	Possible Cause:	Solution:	Check:
Engine Overheating	Low Oil	Check the oil. Refill the oil or change the oil as needed.	Start the engine and let it reach operating temperature. Check the temperature.
	Exhaust pipe blocked	Check the exhaust pipe. If the exhaust pipe is blocked, clear the blockage.	
	Debris in cooling fins	Remove the debris.	
	Improper governor setting	Check the engine speed. Adjust governor as needed.	
	Shroud leaking	Inspect shroud. Repair or replace as needed.	
	Cylinder or piston or piston ring worn	Inspect cylinder, piston, and piston rings. Replace if needed.	
	Connecting rod deformed	Inspect connecting rod. Replace if needed.	
	If the engine still overheats:	Rebuild the engine, replace the engine, or consider replacing the unit	
Engine Runs, But Generator Provides No Power or Low Power	Low engine speed	Check the engine speed. Refer to Engine Speed - Adjust if needed.	Start the engine and check the output voltage
	Circuit breaker or over current protector is open	Close the circuit breaker or overcurrent protector.	
	Bad connection	Stop the engine and check the connections.	
	Defective power cord	Replace the cord.	
	Defective device plugged in	Unplug defective device.	
	Bad AVR connection or defective AVR	Check the voltages and connections. Tighten any loose connections. Replace the AVR.	
	Poor carbon brush contact	Clean the surface of the collector ring and the carbon brush arc surface.	
	Improper brush pressure	Adjust or replace the spring.	
	Poor stator or rotor lead contact	Check the contacts. Tighten or replace as needed.	
	Poor panel, meter, or socket contact		
	Magnetic field lost	Flash the generator.	
	Defective winding or winding connection	Check each winding. Check connections to ground. Check the insulation. Check the excitation loop for an open circuit. Tighten any loose connections and replace any defective parts.	
If there is still no power or low power:	Rebuild the generator, replace the generator, or consider replacing the unit.		
Stator Core Overheating	High stator voltage	Adjust the voltage.	Start the engine and let it reach operating temperature. Check the stator temperature.
	Excitation current too high	Reduce the load on the generator.	
	Low engine speed	Check the engine speed. Refer to Engine Speed - Adjust if needed.	
	Friction between the stator and rotor	Look for signs of wear on the rotor core. Remove any high spots.	
	Stator winding temperature too high	Refer to the section on "Stator Winding Overheating"	
	If the stator core is still overheating:	Rebuild the generator, replace the generator, or consider replacing the unit.	

Issue:	Possible Cause:	Solution:	Check:
Stator Winding Overheating	Too much load	Reduce the load on the generator.	Start the engine and let it reach operating temperature. Check the stator temperature.
	Vent blocked	Check the vents. Clean as needed.	
	Open circuit in stator winding	Check the windings for an open circuit. Repair or replace as needed.	
	Stator winding grounded	Check for a winding that is shorted to ground. Repair or replace as needed.	
	If the stator winding is still overheating:	Rebuild the generator, replace the generator, or consider replacing the unit.	
Rotor Winding Overheating	Low engine speed	Check the engine speed. Adjust if needed.	Start the engine and let it reach operating temperature. Check the rotor temperature.
	Airway blocked	Ensure that all of the air passages are not blocked. Clean the generator if needed.	
	Open circuit in rotor winding	Check the windings for an open circuit. Repair or replace as needed.	
	Rotor winding grounded	Check for a winding that is shorted to ground. Repair or replace as needed.	
	Friction between the stator and rotor	Look for signs of wear on the rotor core. Remove any high spots.	
	If the rotor winding is still overheating:	Rebuild the generator, replace the generator, or consider replacing the unit.	

APPENDIX

Product Specifications

Item		RP2500EU	RP3100EU
Engine	Engine Type	Single Cylinder, 4-Stroke, Forced Air Cooling, OHV	
	Displacement (cc)	212	
	Ignition System	Transistorized Magneto	
	Fuel Volume (L)	16	
	Fuel Consumption (g/(kW·h))	≤395	
	100% load continuous running time (hr)	7	
	50% load continuous running time (hr)	13.5	
	Oil Capacity (L)	0.6	
Generator	Rated Frequency (Hz)	50	
	Rated Voltage (V)	230	
	Rated Output Power (kW)	2.3	2.8
	Maximum Output Power (kW)	2.5	3.1
Generator Set	Length (mm)	721	
	Width (mm)	477	
	Height (mm)	525	
	Net Weight (kg)	49	51.5
	Phase	Single	

Item		RP2500UK	RP3100UK
Engine	Engine Type	Single Cylinder, 4-Stroke, Forced Air Cooling, OHV	
	Displacement (cc)	212	
	Ignition System	Transistorized Magneto	
	Fuel Volume (L)	16	
	Fuel Consumption (g/(kW·h))	≤395	
	100% load continuous running time (hr)	7	
	50% load continuous running time (hr)	13.5	
	Oil Capacity (L)	0.6	
Generator	Rated Frequency (Hz)	50	
	Rated Voltage (V)	115 / 230	
	Rated Output Power (kW)	2.3	2.8
	Maximum Output Power (kW)	2.5	3.1
Generator Set	Length (mm)	721	
	Width (mm)	477	
	Height (mm)	525	
	Net Weight (kg)	49	51.5
	Phase	Single	

Maintenance Specifications

Item	Specification	Min/Max
Maximum speed (no load)	3730 - 3830 rpm	-
Compression	588 - 834 kPa	-
Cylinder sleeve I.D.	70.00 mm	70.025 mm
Cylinder head cover flatness	-	0.10 mm
Piston skirt O.D.	69.985	69.975 mm
Piston to cylinder clearance	0.015 – 0.05 mm	0.12 mm
Piston pin bore I.D.	18.002 mm	18.048 mm
Piston pin O.D.	18.00 mm	17.954 mm
Pin to pin bore clearance	0.002 – 0.014 mm	0.06 mm
Piston ring side clearance	0.015 – 0.045 mm	0.15 mm
Piston ring gap	0.20 – 0.40 mm	1.0 mm
Piston oil ring gap	0.15 – 0.35 mm	1.0 mm
Piston ring width	1.5 mm	1.37 mm
Piston oil ring width	2.5 mm	2.37 mm
Connecting rod piston end I.D.	18.006 mm	18.017 mm
Connecting rod crank end I.D.	30.215 mm	30.225 mm
Oil clearance	0.040 – 0.063 mm	0.12 mm
Crank end side clearance	0.20 – 0.50 mm	1.1 mm
Crankshaft pin O.D.	30.190 mm	30.175 mm
Intake valve clearance	0.05 ± 0.02 mm	-
Exhaust valve clearance	0.07 ± 0.02 mm	-
Intake valve stem I.D.	5.48 mm	5.318 mm
Exhaust valve stem I.D.	5.44 mm	5.275 mm
Valve guide I.D.	5.50 mm	5.572 mm
Intake valve stem clearance	0.02 – 0.044 mm	0.10 mm
Exhaust valve stem clearance	0.06 – 0.087 mm	0.12 mm
Valve seat width	0.8 mm	2.0 mm
Valve spring free length	34.0 mm	32.5 mm
Camshaft intake cam height	27.7 mm	27.45 mm
Camshaft exhaust cam height	27.75 mm	27.5 mm
Camshaft journal O.D.	13.984 mm	13.916 mm
Camshaft bracket I.D.	14.0 mm	14.05 mm
Carburetor main jet	1.7 mm	-
Spark plug gap	0.70 – 0.80 mm	-
Spark plug wire resistance	5 kΩ	-
Ignition coil primary coil resistance	0.8 – 1.0 Ω	-
Ignition coil secondary coil resistance	5.9 – 7.1 kΩ	-
Ignition coil air gap	0.40 – 0.60 mm	-
Generator stator winding resistance	0.35Ω ± 10% at 25°C	-
Generator stator auxiliary winding resistance	3.05Ω ± 10% at 25°C	-
Generator rotor excitation winding resistance	58.5Ω ± 10% at 25°C	-
Generator carbon brush length	10 mm	6 mm

Electrical Schematic European Union

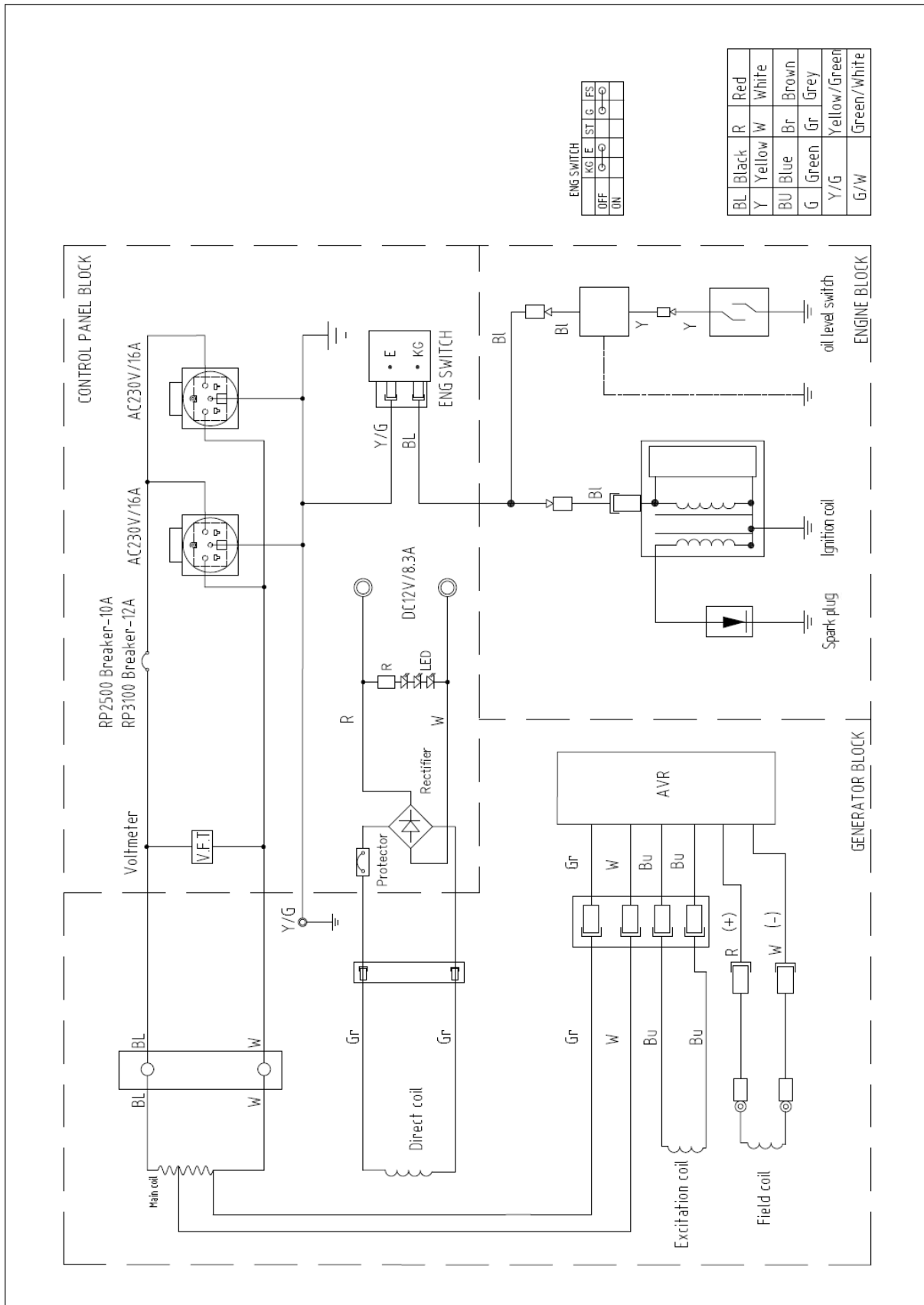

Electrical Schematic United Kingdom

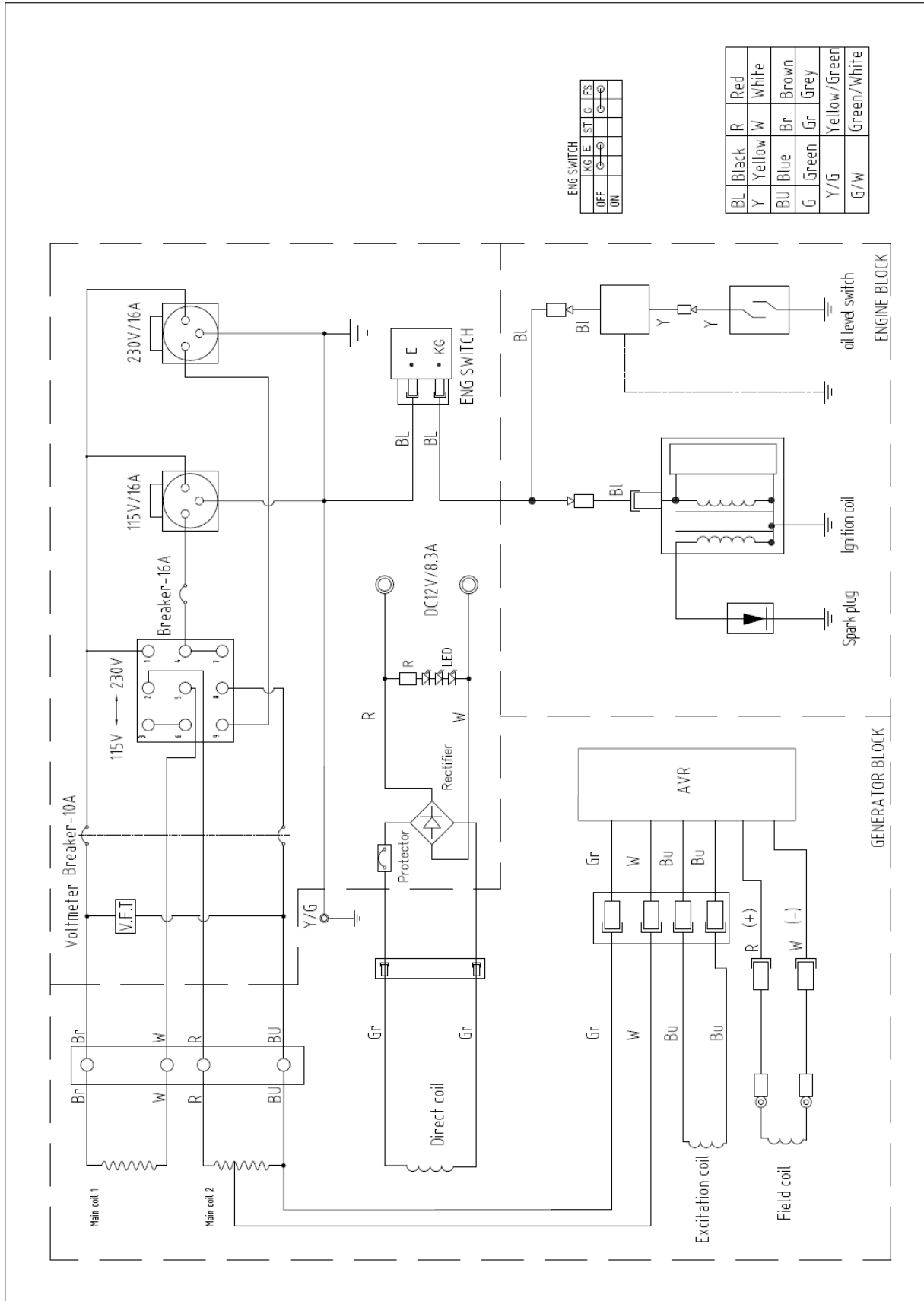

ENG SWITCH		KG	LE	ST	G	FS
OFF	ON	⊖	⊕	⊖	⊕	⊖

BL	Black	R	Red
Y	Yellow	W	White
BU	Blue	Br	Brown
G	Green	Gr	Grey
Y/G	Yellow/Green		
G/W	Green/White		



©2016 Caterpillar
All Rights Reserved

CAT, CATERPILLAR, their respective logos, "Caterpillar Yellow", and the POWER EDGE trade dress as well as corporate and product identity used herein, are trademarks of Caterpillar and may not be used without permission.