

RP4400 Portable Generator



4400 W Maximum | 4000 W Rated

Features

- Reliable power when you need it for home, work and play
- Easy to set up and operate
- Built tough with a heavy-duty frame, never-flat wheels and a hinged handle
- Enhanced safety features like automatic low-oil shutdown, covered wiring and added GFCI protection
- Single-sided, LED illuminated control pane
- All-steel construction



Control Panel

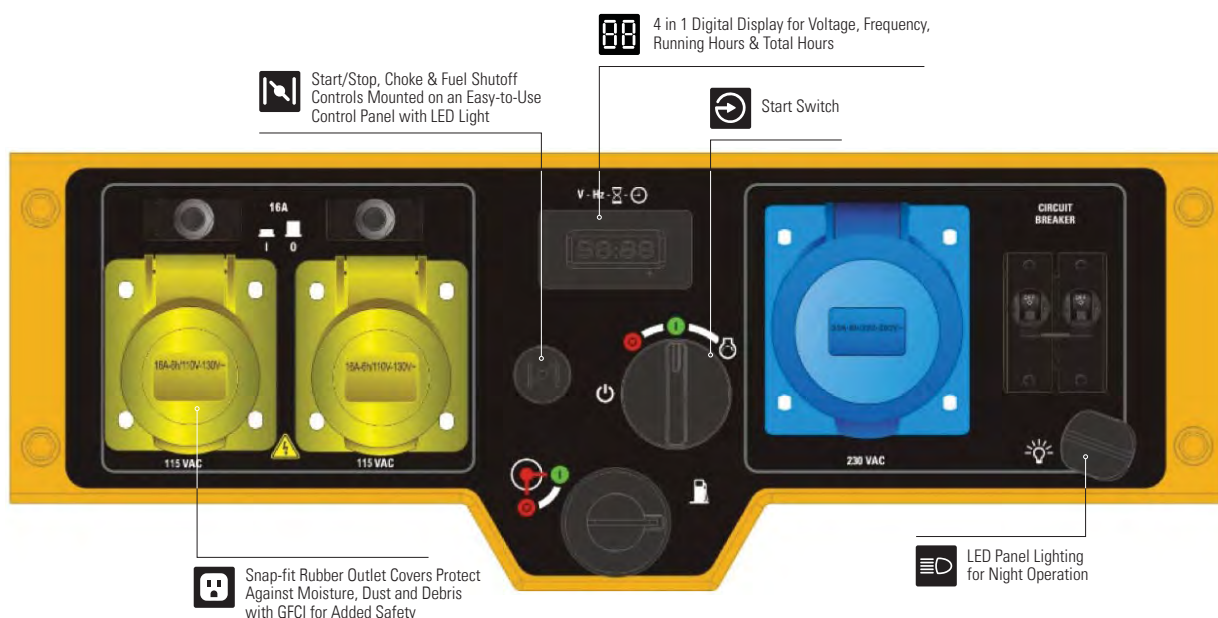

RP4400 Portable Generator



Specifications

ENGINE	
Starting Method	Recoil
Run Time @ 50% Load	18.5 hrs
Idle Control	-
Fuel Tank Nominal Capacity	7.9 gal / 30 L
Fuel Tank Material	Metal
Fuel Type	Gasoline
Fuel Gauge	Dial Gauge
Engine Displacement	300 cc
Engine Type	OHV
Engine Speed	3000 RPM
Lubrication Method	Splash
Recommended Oil	SAE 30 / 10W-30
Oil Capacity	1.1 qt / 1 L
Region Certifications	CE
Shutdown Method	Automatic Low Oil Level

ELECTRICAL	
Maximum Power	4400 Watts
Rated Power	4000 Watts
AC Output	115V / 230V* @ 50 Hz
DC Output	-
Total Harmonic Distortion (THD)	-
Receptacles	2x 115 VAC GFCI 1x 230 VAC
Automatic Voltage Regulation (AVR)	Yes
Battery Type	-

EXTRA FEATURES	
Illuminated Control Panel	Yes
Handle Style	Padded, Double Hinged
Wheel Type	Never-Flat
Indicator Lights	-
USB	-

WARRANTY Standard 2-year limited, extended 3-year limited when registered within 30 days

* 115/230 switchable voltage as standard on UK model only.

Dimensions and Weights

Length in (mm)	32.9 (835)
Width in (mm)	27.4 (696)
Height in (mm)	24.7 (628)
Extended Length in (mm)	45.2 (1148)
Carton Length in (mm)	33.9 (860)
Carton Width in (mm)	21.7 (550)
Carton Height in (mm)	23.4 (593)
Unit Weight lbs (kg)	163.0 (74)
Shipping Weight lbs (kg)	176.2 (80)

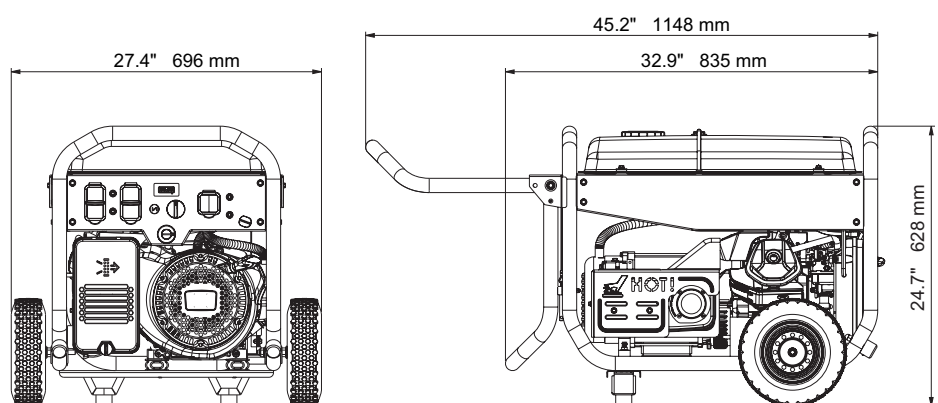

Dealer Contact Information



© 2016 Caterpillar. All Rights Reserved.
CAT, CATERPILLAR, their respective logos, "Caterpillar Yellow," the "Power Edge" trade dress, as well as corporate and product identity used herein, are trademarks of Caterpillar and may not be used without permission.

LEHQ0036-01