

Standby & Prime: 50Hz, 400/230V; 3-Ph



Engine Model	Cat® C7.1 In-line 6, 4-cycle diesel
Bore x Stroke	105 mm x 135 mm (4.1 in x 5.3 in)
Displacement	7.0 L (427.8 in ³)
Compression Ratio	16.8:1
Aspiration	Turbocharged Water cooled
Governor	Mechanical
Emission Strategy	EU stage IIIA emissions compliant

Model	Voltage/Frequency	Standby	Prime
DE175E3	400/230 V, 50 Hz	175 kVA, 140 ekW	160 kVA, 128 ekW

PACKAGE PERFORMANCE

Technical Data	50 Hz	
	Standby	Prime
Engine Speed: RPM	1500	
Gross Engine Power: kW (hp)	162.8 (218.0)	148.1 (199.0)
BMEP: kPa (psi)	1857.0 (269.3)	1689.0 (245.0)
Regenerative Power: kW	12.5	
Fuel System¹ : L/hr (US gal/hr)		
110% Load	-	39.7 (10.5)
100% Load	39.7 (10.5)	36.9 (9.7)
75% Load	31.4 (8.3)	29.2 (7.7)
50% Load	22.4 (5.9)	20.7 (5.5)
Fuel Filter Type	Replaceable Element	
Recommended Fuel	Class A2 Diesel or BSEN590	
Air System		
Combustion Air Flow: m ³ /min (cfm)	12.4 (438)	11.9 (420)
Air Filter Type	Replaceable Element	
Max. Combustion Air intake restriction: kPa (in H ₂ O)	8.0 (32.1)	
Radiator Cooling Air flow: m ³ /min (cfm)	276.0 (9747)	
External Restriction to Cooling Air Flow: Pa (in H ₂ O)	125 (0.5)	
Cooling System²		
Heat Rejected to Water & Lube Oil: kW (Btu/min)	72.5 (4123)	64.0 (3640)
Heat Radiated from Engine & Alternator: kW (Btu/min)	37.3 (2121)	34.8 (1979)
Cooling System Capacity: l (US gal)	21.0 (5.5)	
Radiator Fan Load: kW (hp)	4.5 (6.0)	
Water Pump Type	Centrifugal	

Exhaust System		50 Hz	
	Standby	Prime	
Exhaust Gas Flow: m ³ /min (cfm)	26.6 (939)	26.4 (932)	
Exhaust Gas Temperature: °C (°F)	491 (916)	491 (916)	
Silencer Type	Industrial		
Silencer Model & Quantity	EXSY1 (1)		
Pressure Drop Across Silencer System: kPa (in Hg)	0.17 (0.050)		
Silencer Noise Reduction Level: dB	10		
Max. Allowable Back Pressure: kPa (in. Hg)	15.0 (4.4)		

Generator Performance Data ³			
Voltage	415/240V	400/230V	380/220V
Motor Starting Capability* kVA	224	208	188
Short Circuit Capacity** %	300	300	300
Reactances: Per Unit			
Xd	2.938	3.161	3.501
X'd	0.258	0.277	0.307
X''d	0.108	0.116	0.129

Generator Technical Data			
Physical Data		Operating Data	
Frame Model	R2453L4	Overspeed: RPM	2250
No. of Bearings	1	Voltage Regulation: (steady state)	+/- 0.5%
Wires	12	Wave Form NEMA = TIF:	50
IP Rating & Insulation Class	IP23 & H	Wave Form IEC = THF:	2.0%
Winding Pitch-Code	2/3 - M0	Total Harmonic Content LL/LN:	2.0%
Excitation	SHUNT	Radio Interference:	Suppression is in line with European Standard EN61000-6
AVR Model	Mark V	Radiant Heat: kW (Btu/min)	50 Hz: 10.7 (608)

Capacities		50 Hz			
Voltage	Prime		Standby		
	kVA	kW	kVA	kW	
415/240V	160.0	128.0	175.0	140.0	
400/230V	160.0	128.0	175.0	140.0	
380/220V	160.0	128.0	175.0	140.0	

Weight: kg (lb)			Dimensions: mm (in)		
Net (+ lube oil)	Wet (+ lube oil & coolant)	Fuel, lube oil & coolant	Length, A	Width, B	Height, C
1590 (3505)	1611 (3552)	1907 (4203)	2450 (96.5)	1010 (39.8)	1554 (61.2)

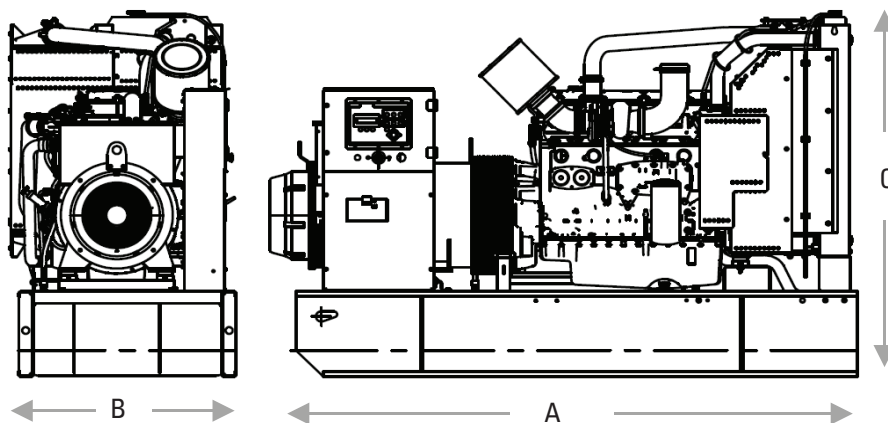

Notes:

¹ Based on diesel fuel with a specific gravity of 0.85 and conforming to BS2869, Class A2.

² Cooling system designed to operate in ambient conditions up to 50°C (122°F). Contact your local Cat dealer for power ratings at specific site conditions.

³ Reactances shown are applicable to prime ratings. *Based on 30% voltage dip at 0 power factor and shunt excitation system. **With optional Auxiliary winding.

DEFINITIONS:

STANDBY: Output available with varying load for the duration of the interruption of the normal source power. Average power output is 70% of the standby power rating. Typical operation is 200 hours per year, with maximum expected usage of 500 hours per year.

PRIME: Output available with varying load for an unlimited time. Average power output is 70% of the prime power rating. Typical peak demand is 100% of prime rated kW with 10% overload capability for emergency use for a maximum of 1 hour in 12. Overload operation cannot exceed 25 hours per year.

Standard Reference Conditions: Note: Standard reference conditions 25°C (77°F) air inlet temp, 100m (328ft) A.S.L. 30% relative humidity. Fuel consumption data at full load with diesel fuel with specific gravity of 0.85 and conforming to BS2869: 1998, Class A2.

Quality Standards: The equipment meets the following standards: IEC60034-1, IEC60034-22, ISO3046, ISO8528, NEMA MG 1-32, NEMA MG 1-33, 2004/108/EC, 2006/42/EC, 2006/95/EC.

LEHE1167-01 (04/18)

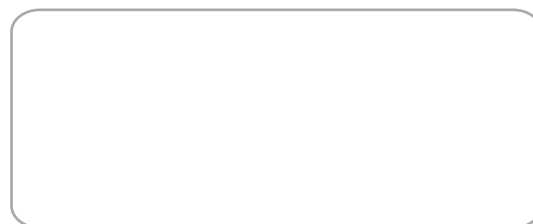

BUILT FOR IT.™