



FB100-2

Prime rating

- Meets latest India CPCBII as per G.S.R 771(E) dated 11/12/2013 and its further amendments.
- Meets CPCB / MOEF norms as per G.S.R 371(T) dated 17/05/2002 and its further amendments.



Genset Technical Data

Genset Rating (kVA)	100
No of Phases	3
Power Factor	0.8
Voltage (V)	415
Frequency (Hz)	50
Current (A)	139
Controller Type	Standard
Starting System	24 V D.C.
Genset Weight (kg)	2200
Noise @ 75% load (dBA)	< 75 @ 1m
Genset Dimensions (LxWxH) (mm)	3626 x 1126 x 2074
Battery Type	2 x 12 Volt
Circuit Breaker Rating (A)	150

Alternator Technical Data

Alternator Make	Leroy Somer
No of Bearings	Single Bearing
Alternator model	LSAP 44.3C
Alternator rating	100
Class of insulation	H
Coupling details	SAE3/11.5"
Voltage Variation (%)	+/- 1
Rated Full load current (A)	139.1

Fuel & Oil Systems Technical Data

Fuel System	Mechanical
Type Of Fuel	HSD
Genset Fuel Tank Capacity (l)	300
Fuel Consumption - @ 100% Load (l/hr)*	21.3
Fuel Consumption - @ 75% Load (l/hr)*	17.2
Fuel Consumption - @ 50% Load (l/hr)*	13
Fuel Consumption Tolerance	0 to +5%
Lube Oil change period (hrs)	500
Oil Type	15W40 CH4
Oil capacity (l)	8.5
Oil Consumption @100% load (l/hr)	< 0.1% of FC

Engine Technical Data

Engine Model	FBD4-4.5D1
Engine Speed (rpm)	1500
Engine Volume (l)	4.5
Rated Power (kW)	100
No. of cylinder	4
Bore (mm)	107
Stroke (mm)	126
Compression Ratio	17.5:1
Aspiration	TC-IC
Cooling System	Liquid Cooled
Cooling System Capacity (l)	17
Governing	Mechanical A2 Class

*sp.gr of fuel - 0.835kg/litre
 Standard operating conditions as per ISO3046 / ISO8528
 Prime Rating as per ISO8528

FB100-2

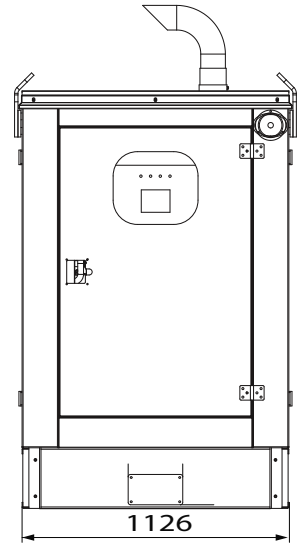
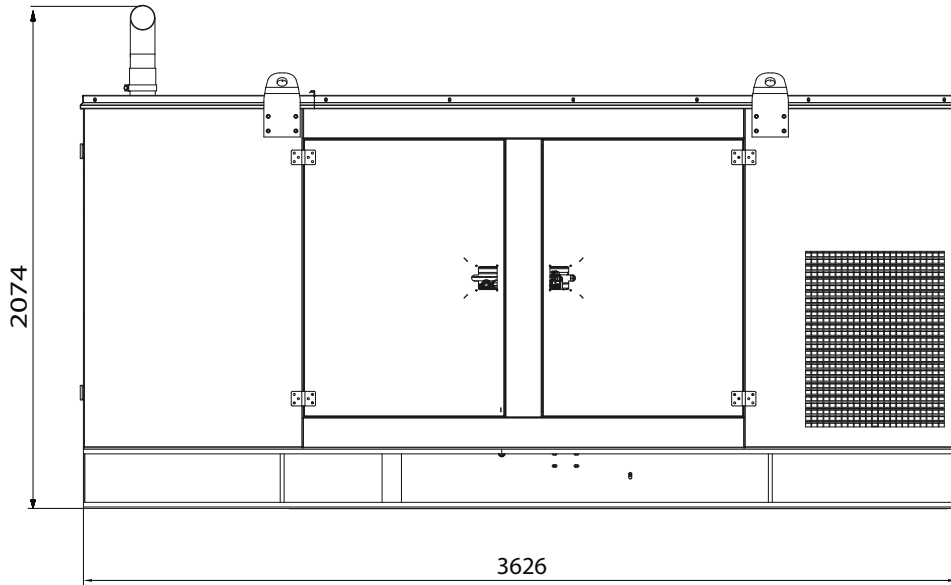

Dealer Contact Details

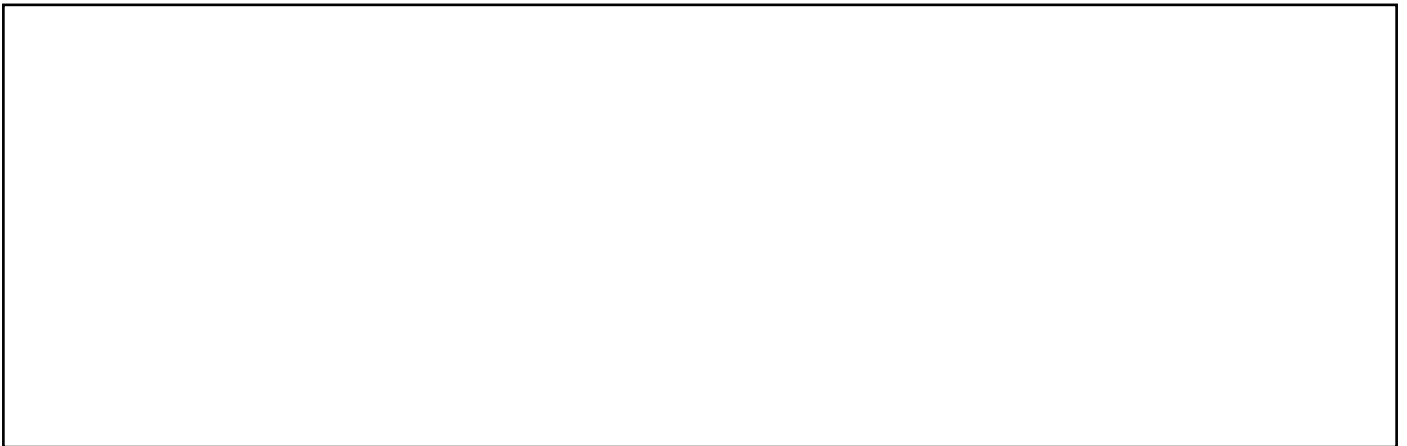

FG Wilson manufactures product in the following locations:

Northern Ireland • Brazil • China • India • USA

With headquarters in Northern Ireland, FG Wilson operates through a Global Dealer Network. To contact your local Sales Office please visit the FG Wilson website at www.FGWilson.com.

FG Wilson is a trading name of Caterpillar (NI) Limited.

In line with our policy of continuous product development, we reserve the right to change specification without notice.