

313D2 L

Hydraulic Excavator
2017



Engine

Engine Model	Cat® C4.4	
Engine Power (ISO 14396)	75 kW	100 hp
Net Power (SAE J1349/ISO 9249)	68 kW	91 hp

Weights

Minimum Operating Weight	13 400 kg	29,550 lb
Maximum Operating Weight	14 100 kg	31,090 lb

313D2 L Features

Engine and Hydraulics

The powerful C4.4 engine meets U.S. EPA Tier 3, EU Stage IIIA, Japan 2006 (Tier 3) equivalent and China Nonroad Stage III emission standards and is combined with a highly efficient hydraulics system providing excellent machine performance with low fuel consumption.

Structures

Caterpillar design and manufacturing techniques assure outstanding durability and service life.

Operator Station

The spacious cab features excellent visibility and easy-to-access switches. The monitor features a full-color graphical display which is user intuitive and highly visual with built-in pre-start machine checks. Overall, the new cab provides a comfortable working environment for efficient day-long operation.

Service and Maintenance

This machine has been designed so that routine service and maintenance can be completed quickly and easily to help reduce ownership costs. Convenient access points with extended intervals and advanced filtration keeps down-time to a minimum.

Complete Customer Support

Your Cat dealer offers a wide range of services that can be set up under a customer support agreement when you purchase your equipment.

Cat 313D2 L Total Solutions

Caterpillar and its extensive dealer network offer a wide variety of solutions designed to meet the unique needs of your business.

Contents

Operator Station.....	4
Engine	5
Hydraulics	6
Undercarriage and Structures	7
Front Linkage	7
Work Tools.....	8
Serviceability.....	10
Complete Customer Support.....	11
Specifications.....	12
Standard Equipment.....	24
Optional Equipment.....	25
Notes.....	26





Achieve high productivity and lower operating costs with the Cat 313D2 L Hydraulic Excavator. Unmatched versatility, improved controllability, easy operation and a comfortable, redesigned operator station help make the 313D2 L an industry-leading performer.

Operator Station

Enhanced comfort, operation and visibility.

Operator Station

The ergonomically designed operator station is spacious, quiet and comfortable, assuring high productivity during a long work day. All switches are located on the right-hand console for convenient access.

Monitor

The monitor is a full-color Liquid Crystal Display (LCD) that can be adjusted to minimize sun glare. It has the capability of displaying information in Chinese and twenty-seven other languages.

Joystick Control

Low-effort pilot-operated joystick controls are designed to match the operator's natural wrist and arm position for maximum comfort and minimum fatigue.

Seat

The suspension seat provides a variety of adjustments to accommodate a wide range of operators. All seats include a reclining back, upper and lower seat slide adjustments, and height and tilt adjustments, to meet operator needs for comfort and productivity.

Console

The right and left joystick console can be adjusted to meet individual preferences, improving operator comfort and productivity during the course of a day.

Cab Exterior

The cab shell features thick steel tubing along the bottom perimeter of the cab, improving resistance to fatigue and vibration.

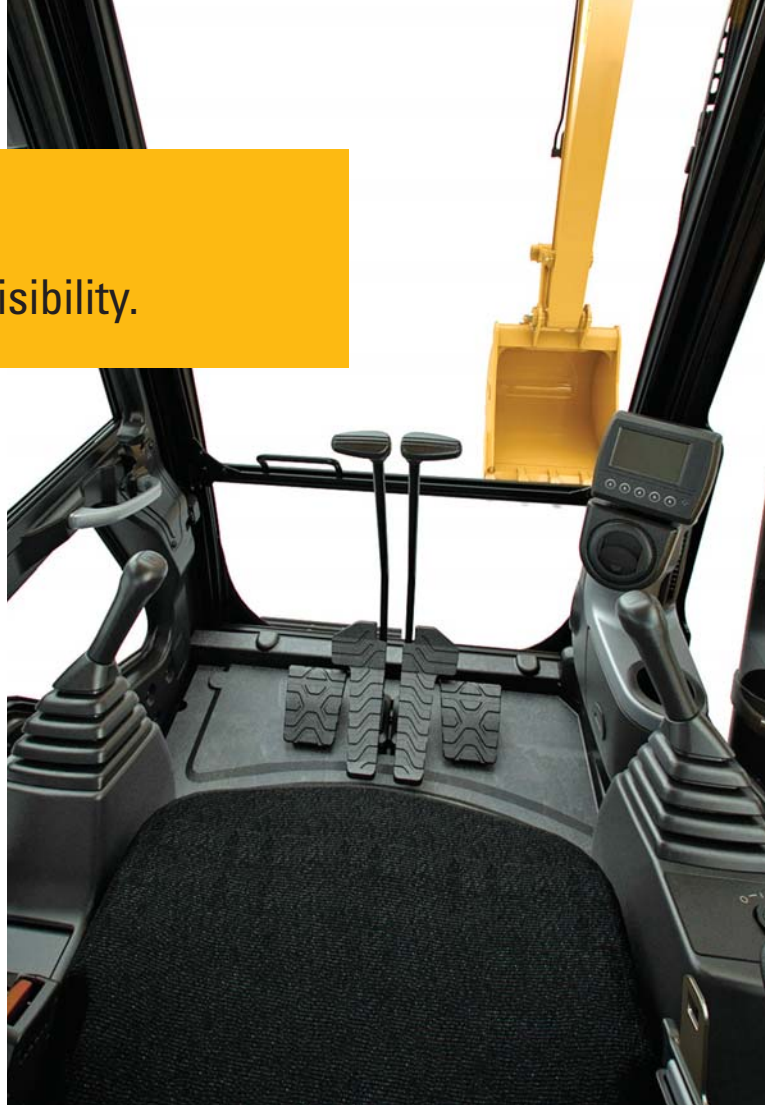

Cab Structure and Mounts

The cab shell is attached to the frame with viscous rubber cab mounts, which dampen vibrations and sound levels while enhancing operator comfort. Thick steel tubing along the bottom perimeter of the cab, improves resistance to fatigue and vibration.

Windows

To maximize visibility, all glass is affixed directly to the cab, eliminating window frames. The upper front windshield opens, closes and stores on the roof above the operator with a one-touch action release system.

Wipers

Pillar-mounted wipers increase the operator's viewing area and offer continuous and intermittent modes.

Engine

Delivering the most work per liter
of fuel consumed.

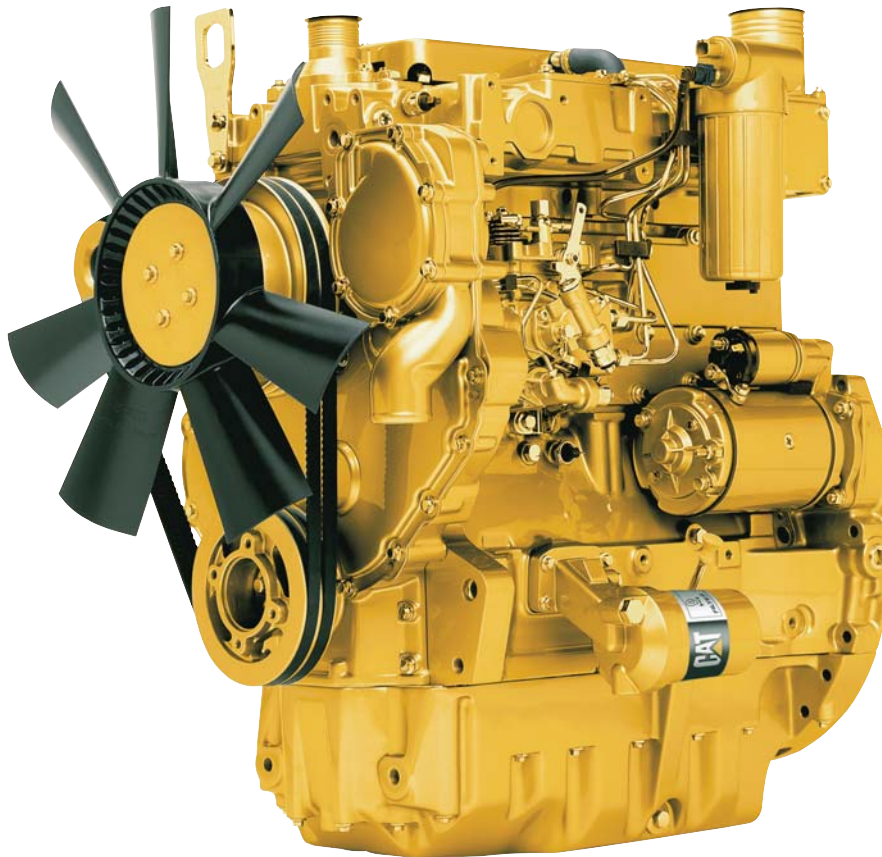

The Cat C4.4 engine has been designed to meet Tier 3, Stage IIIA, Japan 2006 (Tier 3) equivalent and China Nonroad Stage III emission standards. This engine incorporates a time-proven mechanical governor and a low pressure fuel injection system which are major contributors to the improvement of fuel system robustness, high fuel efficiency and ease of troubleshooting. High filtration performance from the primary filter incorporating a water separator and a secondary filter also help to improve fuel filtration system reliability.

Automatic Engine Control and Fuel Delivery

With a net power of 68 kW (91 hp) the 313D2 L has been designed with fuel economy in mind.

Economy Mode

Available as standard, economy mode allows you to balance the demands of performance and fuel economy while maintaining the breakout forces and lift capacity enjoyed at standard power.



Hydraulics

Low effort and precise control for highly efficient performance.

Outstanding Performance

The 313D2 L hydraulic system is designed for high efficiency and performance. This compact design utilizes short tubes and lines, reducing friction and pressure drops, resulting in a more efficient use of power.

- Hydraulic snubbers at the rod end of the boom cylinders and both ends of the stick cylinder cushion shock, reduce sound and increase cylinder life.
- Flow is reduced to a minimum when controls are in the neutral position to reduce fuel consumption and extend component life.
- Electronic under speed control electronically adjusts pump output to not exceed engine power, preventing the need to reserve engine power to avoid engine stalls.
- Hydraulic cross-sensing system uses two hydraulic pumps up to 100 percent of engine power under all operating conditions, improving productivity with faster implement speeds and quicker, stronger pivot turns.

Boom and Stick Regeneration Circuit

The boom and stick regeneration circuit saves energy during boom-down and stick-in operation, increasing efficiency and lowering operating costs.

Easy Operation

Work mode and power mode switches have been eliminated making full power available at all times. Operators do not need to learn different modes, an automatic boom and swing priority function automatically selects the best mode based on joystick movement.

Undercarriage and Structures

Strong, stable and easy to maneuver.

Caterpillar uses advanced engineering and software to analyze all structures, creating a durable, reliable machine for the robust applications. More than 70 percent of the structural welds are robotic and achieve three times the penetration over manual welds. These structural components and undercarriage are the backbone of the machine's durability.

Carbody Design

X-shaped, box-section carbody provides excellent resistance to torsional bending. Robot-welded track roller frames are press-formed, pentagonal units that deliver exceptional strength and service life.

Grease Lubricated Track

Grease lubricated track seals protect the track link and deliver long track link pin and bushing inner wear.

Travel Motors

Travel motors with automatic speed selection let the 313D2 L automatically change up and down from high and low speeds in a smooth, controlled manner.



Front Linkage

Reliable and durable meeting all your versatility needs.

Robust applications require robust machine designs. In order to meet your job site needs we use advanced engineering and software to analyze all structures, creating a durable, reliable machine.

Stick

The 2.5 m (8'2") and 3 m (9'10") reach sticks incorporate new forging and welding processes for increased durability, digging force, and lifting capacity.

Reach Boom

A 4.65 m (15'3") one-piece, reach boom features parts made from a new forging pattern. A light attached to the left side offers improved visibility in dark and low-light conditions.



Work Tools

Dig, hammer, rip, and cut with confidence.

Each Cat work tool is designed to optimize the versatility and performance of your machine. An extensive range which includes buckets, compactors, grapples, multi-processors, rippers, crushers, pulverizers, hammers and shears is available for your 313D2 L.

Couplers

Quick couplers allow one person to change work tools in seconds for maximum performance and flexibility on a job site. One machine can move rapidly from task to task, and a fleet of similarly equipped machines can share a common work tool inventory.

CW Dedicated Coupler

The CW quick coupler can pick up any work tool and is equipped with a wedge-style locking system that fits the quick coupler tight to the tool hinges. Due to the tapered wedge design, there won't be any play during its entire life. Also it is interchangeable with different machine classes. The CW is highly suitable for harsh applications, such as demolition and quarries.

Cat Pin Grabber Coupler

The Cat Pin Grabber Coupler is easy to activate, easy to engage, easy to disengage. Operating procedures are simple and easy to learn. It's the easiest way to improve productivity on every job site.

One excavator can share buckets and a variety of attachments with similar size excavators. Managing your assets just got easier.

Note: Offerings vary for different regions.



Buckets

Cat Buckets and Cat Ground Engaging Tools (GET) are designed and matched to the machine ensuring optimal performance and fuel consumption.

General Duty Buckets (GD)

These buckets are designed for digging in low-impact, moderately abrasive materials such as dirt, loam, gravel and clay.

Heavy Duty Buckets (HD)

HD buckets are a good starting point when application conditions vary. Especially when conditions include mixed dirt, clay and sand and gravel.

Severe Duty Buckets (SD)

These buckets are best suited to highly abrasive applications such as shot rock, sand stone and granite.

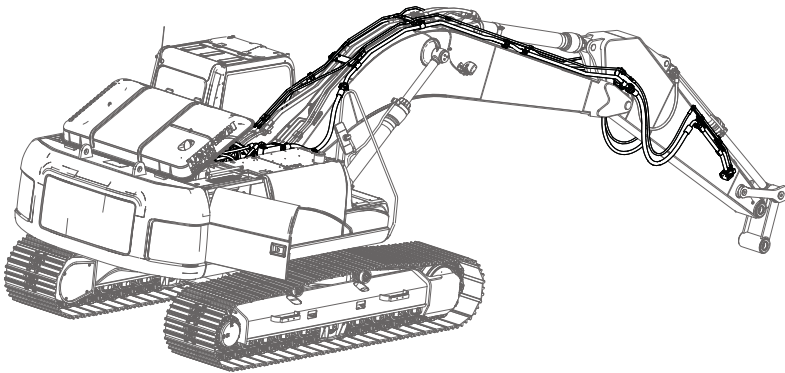

Hydraulic Kits*

Caterpillar offers field-installed hydraulic kits that are uniquely designed to integrate Cat Work Tools with Cat excavators. Hoses and tubes are pre-made, pre-shaped, and pre-painted to make installation quick and easy.

Comprehensive Product Support

All Cat work tools are backed up by a world-wide network of well-stocked spare parts depots and highly experienced after-sales service and support personnel.

*Offering varies for different regions

Work tools available vary by region. Contact your local Cat dealer for more information about the work tools available in your region.



Serviceability

Simplified service and maintenance features save you time and money.

Ground Level Service

The design and layout of the 313D2 L was made with the service technician in mind. Many service locations are easily accessible from ground level allowing service and maintenance to get completed quickly and efficiently.

Pump Compartment

A service door on the right side of the upper structure allows ground-level access to the hydraulic pumps, hydraulic filters, and engine oil filter.

Radiator Compartment

The left service door allows easy access to the engine radiator, hydraulic oil cooler, water separator, primary and secondary fuel filter, and AC condenser. A reserve tank and drain cock are attached to the radiator for simplified ground level maintenance.

The air filter features a double-element construction for superior cleaning efficiency. When the air cleaner plugs, a warning is displayed on the monitor screen inside the cab. Maintenance free batteries are standard along with a battery disconnect switch.

Hydraulic Filter

The hydraulic return filter is an in-tank design with a service life of 2,000 hours. A sensor indicates through the in-cab monitor when the filter is plugged and needs to be replaced.

Greasing Points

A concentrated remote greasing block on the boom allows the greasing of hard-to-reach locations on the boom and stick.

Fan Guard

Engine radiator fan is 180 degree enclosed by fine wire mesh, which provides maximum protection when carrying out routine service and maintenance.

Anti-Skid Plate

Anti-skid plating covers the entire upper structure along with the tool box to prevent slipping during maintenance.



Diagnostics and Monitoring

The 313D2 L is equipped with Scheduled Oil Sampling (S.O.SSM) ports for the hydraulic system, engine oil, and coolant. Standard hydraulic test ports situated throughout the hydraulic system enable quick and easy fault finding in the event of a problem.

Extended Service Interval

313D2 L service and maintenance intervals have been extended to reduce machine service time and increase machine availability.



Complete Customer Support

Cat dealer services offer a wide range of personalized solutions.

Product Support

Cat dealers utilize a worldwide computer network to find in-stock parts to minimize machine downtime. You can also save money with our line of remanufactured components.

Machine Selection

Your Cat dealers can provide specific recommendations with detailed comparisons of the Cat machines you are considering before you buy. This ensures you get the right sized machine and appropriate work tools to meet all of your application needs.

Maintenance Services

Repair option programs guarantee the cost of repairs up front. Condition Monitoring Services and Diagnostic programs such as Scheduled Oil Sampling, Coolant Sampling and Technical Analysis help you avoid unscheduled repairs.

Customer Support Agreements

Cat dealers offer a variety of product support agreements which can be tailored to meet your specific needs. These plans can cover the entire machine – including attachments – to help protect your investment.

Replacement

Repair, rebuild, or replace? Your Cat dealers can help you evaluate the costs involved so you can make the right choice.

313D2 L Hydraulic Excavator Specifications

Engine

Engine Model	Cat C4.4	
Engine Power – ISO 14396	75 kW	100 hp
Net Power – SAE J1349/ISO 9249	68 kW	91 hp
Bore	105 mm	4.13 in
Stroke	127 mm	5 in
Displacement	4.4 L	268.5 in ³

- Net power advertised is the power available at the flywheel when the engine is equipped with fan, air cleaner, muffler and alternator.
- No engine derating required below 2300 m (7,546 ft) altitude.
- The 313D2 L meets emission standards of Tier 3, Stage IIIA, Japan 2006 (Tier 3) equivalent and China Nonroad Stage III.
- The 313D2 L meets the Stage I of sound regulation.

Weights

Minimum Operating Weight*	13 400 kg	29,550 lb
Maximum Operating Weight**	14 100 kg	31,090 lb

*Reach boom 4.65 m (15'3"), R2.5 m (8'2") stick, 500 mm (20") triple grousers track shoes, GD 0.53 m³ (0.69 yd³) bucket.

**Reach boom 4.65 m (15'3"), R3.0 m (9'10") stick, 770 mm (20") triple grousers track shoes, GD 0.53 m³ (0.69 yd³) bucket.

Swing Mechanism

Swing Speed	12.2 rpm	
Swing Torque	30.9 kN·m	22,825 lbf-ft

Drive

Maximum Travel Speed	5.6 km/h	3.5 mph
Maximum Drawbar Pull	114 kN	25,628 lbf

Hydraulic System

Main System – Maximum Flow (Total)	254 L/min	67 gal/min
Swing System – Maximum Flow	127 L/min	34 gal/min
Maximum Pressure – Equipment	30 500 kPa	4,424 psi
Maximum Pressure – Travel	35 000 kPa	5,076 psi
Maximum Pressure – Swing	23 000 kPa	3,336 psi
Pilot System – Maximum Flow	21.9 L/min	5.79 gal/min
Pilot System – Maximum Pressure	4120 kPa	598 psi
Boom Cylinder – Bore	110 mm	4.33 in
Boom Cylinder – Stroke	1015 mm	40 in
Stick Cylinder – Bore	120 mm	4.72 in
Stick Cylinder – Stroke	1197 mm	47.1 in
Bucket Cylinder – Bore	100 mm	3.93 in
Bucket Cylinder – Stroke	939 mm	37 in

Service Refill Capacities

Fuel Tank Capacity	250 L	66.05 gal
Cooling System	17.88 L	4.73 gal
Engine Oil (with filter)	16 L	4.23 gal
Swing Drive	3 L	0.8 gal
Final Drive (each)	3 L	0.8 gal
Hydraulic System (including tank)	96 L	25.4 gal
Hydraulic Tank	72.6 L	19.2 gal

313D2 L Hydraulic Excavator Specifications

Dimensions

All dimensions are approximate.

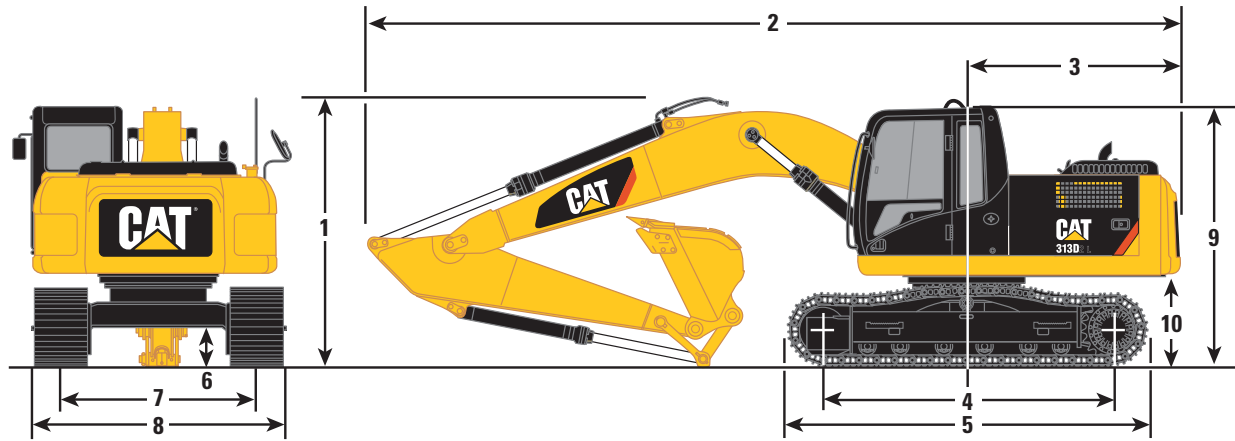

Boom Options

Reach Boom
4.65 m (15'3")

Stick Options

R3.0 (9'10")

R2.5 (8'2")

Stick Options	R3.0 (9'10")	R2.5 (8'2")
1 Shipping Height*	2830 mm (9'3")	2830 mm (9'3")
Shipping Height with Guard Rail	2830 mm (9'3")	2830 mm (9'3")
2 Shipping Length		
Long Undercarriage	7620 mm (25'0")	7610 mm (25'0")
Long Undercarriage with Blade	7970 mm (26'2")	7960 mm (26'1")
3 Tail Swing Radius	2140 mm (7'0")	2140 mm (7'0")
4 Length to Center of Rollers		
Long Undercarriage	3040 mm (10'0")	3040 mm (10'0")
5 Track Length		
Long Undercarriage	3750 mm (12'4")	3750 mm (12'4")
6 Ground Clearance**	430 mm (1'5")	430 mm (1'5")
7 Track Gauge	1990 mm (6'6")	1990 mm (6'6")
8 Transport Width		
500 mm (20") Shoes	2490 mm (8'2")	2490 mm (8'2")
600 mm (24") Shoes	2590 mm (8'6")	2590 mm (8'6")
770 mm (30") Shoes	2760 mm (9'1")	2760 mm (9'1")
9 Cab Height	2760 mm (9'1")	2760 mm (9'1")
Cab Height with Top Guard	2900 mm (9'6")	2900 mm (9'6")
10 Counterweight Clearance**	900 mm (2'11")	900 mm (2'11")
Bucket	GD	GD
Capacity	0.53 m ³ (0.69 yd ³)	0.53 m ³ (0.69 yd ³)
Tip Radius	1200 mm (3'11")	1200 mm (3'11")

*Including shoe lug height.

**Without shoe lug height.

Note: Offerings vary for different regions.

313D2 L Hydraulic Excavator Specifications

Working Ranges

All dimensions are approximate.

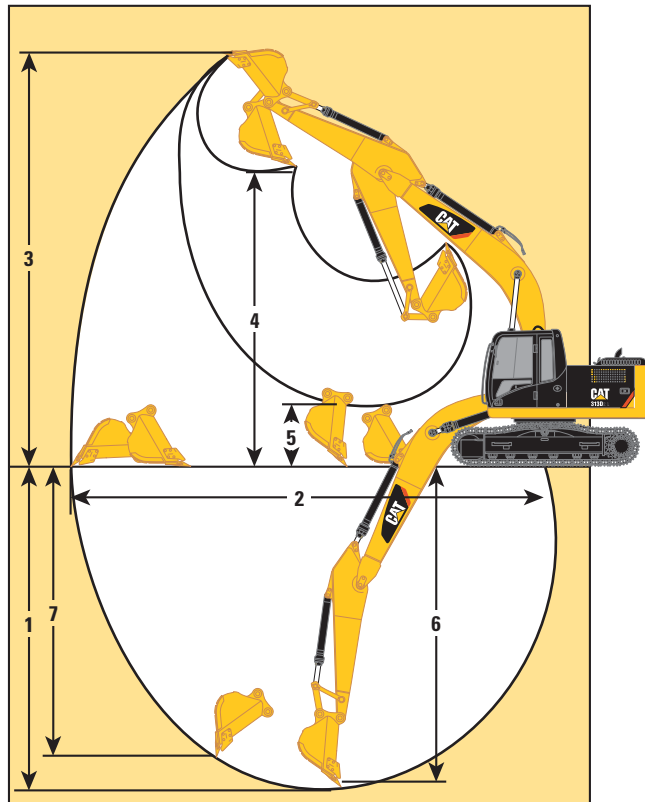

Boom Options

**Reach Boom
4.65 m (15'3")**

Stick Options

R3.0 (9'10")

R2.5 (8'2")

		R3.0 (9'10")	R2.5 (8'2")
1	Maximum Digging Depth	6040 mm (19'10")	5540 mm (18'2")
2	Maximum Reach at Ground Level	8630 mm (28'4")	8180 mm (26'10")
3	Maximum Cutting Height	8710 mm (28'7")	8490 mm (27'10")
4	Maximum Loading Height	6330 mm (20'9")	6100 mm (20'0")
5	Minimum Loading Height	1530 mm (5'0")	2010 mm (6'7")
6	Maximum Depth Cut for 2440 mm Level Bottom	5860 mm (19'3")	5330 mm (17'6")
7	Maximum Vertical Wall Digging Depth	4990 mm (16'4")	4640 mm (15'3")
Bucket	Type	GD	GD
	Capacity	0.53 m ³ (0.69 yd ³)	0.53 m ³ (0.69 yd ³)
	Tip Radius	1200 mm (3'11")	1200 mm (3'11")

313D2 L Hydraulic Excavator Specifications

Operating Weight and Ground Pressure

	770 mm (30") Triple Grouser Shoes		600 mm (24") Triple Grouser Shoes		500 mm (20") Triple Grouser Shoes	
Long Undercarriage without Blade						
Reach Boom – 4.65 m (15'3")						
R3.0 (9'10")	14 100 kg (31,090 lb)	27.3 kPa (3.96 psi)	13 700 kg (30,210 lb)	40.3 kPa (4.93 psi)	13 500 kg (29,770 lb)	40.3 kPa (5.85 psi)
R2.5 (8'2")	14 000 kg (30,870 lb)	27.1 kPa (3.93 psi)	13 600 kg (29,990 lb)	33.8 kPa (4.90 psi)	13 400 kg (29,550 lb)	40.0 kPa (5.80 psi)

Weights are rounded up to nearest 100 kg and lb including GD 0.53 m³ (0.69 yd³) bucket (500 kg/1,100 lb).

*Offering varies for different regions.

Major Component Weights

Base Machine (with boom cylinder, without counterweight, front linkage and track)	4490 kg (9,900 lb)
Undercarriage	
Long Undercarriage	2580 kg (5,690 lb)
Counterweight	
Heavy Duty Counterweight	2650 kg (5,840 lb)
Boom (includes lines, pins and stick cylinder)	
Reach Boom – 4.65 m (15'3")	1030 kg (2,270 lb)
Stick (includes lines, pins and bucket cylinder)	
R3.0 (9'10")	650 kg (1,430 lb)
R2.5 (8'2")	570 kg (1,260 lb)
Track Shoe (Long/per two tracks)	
500 mm (20") Triple Grouser	1570 kg (3,460 lb)
600 mm (24") Triple Grouser	1820 kg (4,010 lb)
770 mm (30") Triple Grouser	2230 kg (4,920 lb)
Quick Coupler – Cat Pin Grabber Coupler with Pin	480 kg (1,060 lb)

All weights are rounded up to nearest 10 kg and lb except for quick coupler and buckets. Kg and lb were rounded up separately so some of the kg and lb do not match.

Base machine includes 75 kg (165 lb) operator weight and 90% fuel weight, and undercarriage with center guard.

313D2 L Hydraulic Excavator Specifications

313D2 L Bucket Specifications and Compatibility (Africa, Middle East & CIS)

Without Quick Coupler								313D2 L						
	Width		Capacity		Weight		Fill	Reach Boom						
	mm	in	m ³	yd ³	kg	lb		%	3.0	2.5	3.0	2.5	3.0	2.5
									500 mm (20") TG		600 mm (24") TG		770 mm (30") TG	
General Duty (GD)	600	24	0.31	0.40	315	694	100	●	●	●	●	●	●	
	750	30	0.41	0.54	362	799	100	●	●	●	●	●	●	
	900	36	0.53	0.69	411	905	100	●	●	●	●	●	●	
	1000	39	0.60	0.78	436	960	100	●	●	●	●	●	●	
	1100	43	0.68	0.89	470	1,036	100	⊙	●	⊙	●	⊙	●	
	1200	48	0.76	1.00	499	1,100	100	X	X	X	X	X	X	
Heavy Duty (HD)	450	18	0.20	0.27	276	608	100	●	●	●	●	●	●	
	1200	48	0.76	1.00	506	1,115	100	X	X	X	X	X	X	
Maximum load pin-on (payload + bucket)							kg	1750	1970	1765	1980	1820	2045	
							lb	3,857	4,342	3,890	4,364	4,011	4,507	

With Cat Pin Grabber Coupler								313D2 L						
	Width		Capacity		Weight		Fill	Reach Boom						
	mm	in	m ³	yd ³	kg	lb		%	3.0	2.5	3.0	2.5	3.0	2.5
									500 mm (20") TG		600 mm (24") TG		770 mm (30") TG	
General Duty (GD)	600	24	0.31	0.40	315	694	100	●	●	●	●	●	●	
	750	30	0.41	0.54	362	799	100	●	●	●	●	●	●	
	900	36	0.53	0.69	411	905	100	●	●	●	●	●	●	
	1000	39	0.60	0.78	436	960	100	⊙	●	⊙	●	⊙	●	
	1100	43	0.68	0.89	470	1,036	100	⊖	⊙	⊖	⊙	⊖	⊙	
	1200	48	0.76	1.00	499	1,100	100	○	⊖	○	⊖	○	⊖	
Heavy Duty (HD)	450	18	0.20	0.27	276	608	100	●	●	●	●	●	●	
	1200	48	0.76	1.00	506	1,115	100	○	⊖	○	⊖	○	⊖	
Maximum load pin-on (payload + bucket)							kg	1504	1724	1519	1734	1574	1799	
							lb	3,315	3,800	3,348	3,822	3,470	3,965	

The above loads are in compliance with hydraulic excavator standard EN474, they do not exceed 87% of hydraulic lifting capacity or 75% of tipping capacity with front linkage fully extended at ground line with bucket curled.

Capacity based on ISO 7451.

Bucket weight with Long tips

Maximum Material Density:

- 2100 kg/m³ (3,500 lb/yd³)
- ⊙ 1800 kg/m³ (3,000 lb/yd³)
- ⊖ 1500 kg/m³ (2,500 lb/yd³)
- 1200 kg/m³ (2,000 lb/yd³)
- X Not recommended

313D2 L Hydraulic Excavator Specifications

313D2 L Bucket Specifications and Compatibility (South America)

Without Quick Coupler								313D2 L						
	Width		Capacity		Weight		Fill	Reach Boom						
	mm	in	m ³	yd ³	kg	lb		%	3.0	2.5	3.0	2.5	3.0	2.5
									500 mm (20") TG		600 mm (24") TG		770 mm (30") TG	
General Duty (GD)	1200	48	0.76	1.00	510	1,125	100	⊖*	⊙*	⊖*	⊙*	⊙*	●*	
Severe Duty (SD)	900	36	0.53	0.69	483	1,065	90	●	●	●	●	●	●	
	1050	42	0.65	0.84	529	1,166	90	●	●	●	●	●	●	
Maximum load pin-on (payload + bucket)							kg	1750	1970	1765	1980	1820	2045	
							lb	3,857	4,342	3,890	4,364	4,011	4,507	

With Cat Pin Grabber Coupler								313D2 L						
	Width		Capacity		Weight		Fill	Reach Boom						
	mm	in	m ³	yd ³	kg	lb		%	3.0	2.5	3.0	2.5	3.0	2.5
									500 mm (20") TG		600 mm (24") TG		770 mm (30") TG	
General Duty (GD)	1200	48	0.76	1.00	510	1,125	100	○	⊖	○	⊖	○	⊖	
Severe Duty (SD)	900	36	0.53	0.69	483	1,065	90	●	●	●	●	●	●	
	1050	42	0.65	0.84	529	1,166	90	⊖	●	⊖	●	⊙	●	
Maximum load pin-on (payload + bucket)							kg	1504	1724	1519	1734	1574	1799	
							lb	3,315	3,800	3,348	3,822	3,470	3,965	

*Recommended for General Duty applications.

The above loads are in compliance with hydraulic excavator standard EN474, they do not exceed 87% of hydraulic lifting capacity or 75% of tipping capacity with front linkage fully extended at ground line with bucket curled.

Capacity based on ISO 7451.

Bucket weight with Long tips

Maximum Material Density:

- 2100 kg/m³ (3,500 lb/yd³)
- ⊙ 1800 kg/m³ (3,000 lb/yd³)
- ⊖ 1500 kg/m³ (2,500 lb/yd³)
- 1200 kg/m³ (2,000 lb/yd³)

313D2 L Hydraulic Excavator Specifications

Reach Boom Lift Capacities – Counterweight: 2.65 mt (5,840 lb) – without Bucket

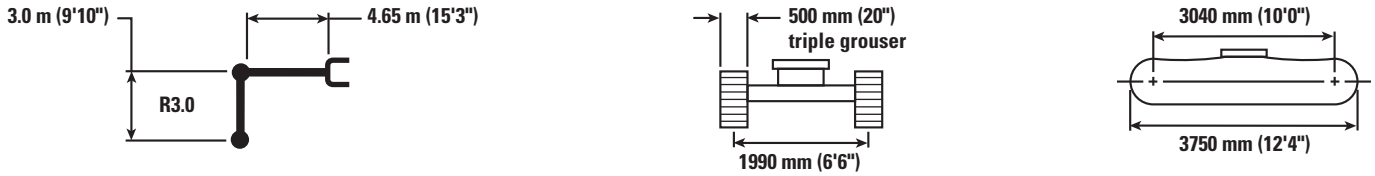

		1500 mm/60 in		3000 mm/120 in		4500 mm/180 in		6000 mm/240 in		7500 mm/300 in				mm in
7500 mm 300 in	kg lb											*2550	*2550	4370
6000 mm 240 in	kg lb											*2100	*2100	5950
												*4,650	*4,650	240
4500 mm 180 in	kg lb							*3150 *6,900	2550 5,450			*2000 *4,350	*2000 *4,350	6860 270
3000 mm 120 in	kg lb					*3850 *8,400	3800 8,200	*3450 *7,500	2450 5,300			*2000 *4,350	1800 3,900	7360 290
1500 mm 60 in	kg lb			*7550 *16,250	6500 13,950	*4900 *10,650	3550 7,650	3650 7,800	2350 5,050	*2150	1700	*2050 *4,550	1700 3,700	7520 300
0 mm 0 in	kg lb			*7850 *18,150	6050 12,950	5450 11,650	3350 7,200	3550 7,600	2250 4,850			*2300 *5,000	1700 3,700	7380 290
-1500 mm -60 in	kg lb	*4500 *10,050	*4500 *10,050	*9350 *20,200	5900 12,650	5300 11,400	3250 7,000	3450 7,450	2200 4,750			*2700 *5,900	1850 4,000	6910 280
-3000 mm -120 in	kg lb	*7500 *16,850	*7500 *16,850	*8550 *18,500	5950 12,800	5300 11,400	3250 7,000	3500 7,700	2250 4,900			3450 7,700	2200 4,900	6040 240
-4500 mm -180 in	kg lb			*6450 *13,700	6150 13,250	*4050	3400					*4000 *8,800	3350 7,650	4530 180



ISO 10567



*Indicates that the load is limited by hydraulic lifting capacity rather than tipping load. The above loads are in compliance with hydraulic excavator lift capacity standard ISO 10567:2007. They do not exceed 87% of hydraulic lifting capacity or 75% of tipping load. Weight of all lifting accessories must be deducted from the above lifting capacities. Lifting capacities are based on the machine standing on a firm, uniform supporting surface. The use of a work tool attachment point to handle/lift objects, could affect the machine lift performance.









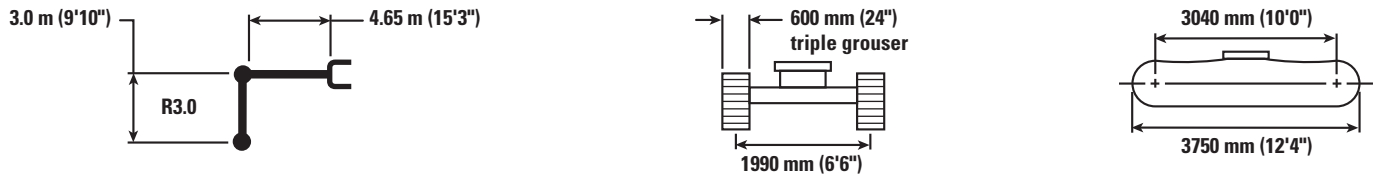

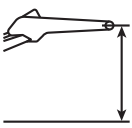



Lift capacity stays with ±5% for all available track shoes.

Always refer to the appropriate Operation and Maintenance Manual for specific product information.

313D2 L Hydraulic Excavator Specifications

Reach Boom Lift Capacities – Counterweight: 2.65 mt (5,840 lb) – without Bucket



		1500 mm/60 in		3000 mm/120 in		4500 mm/180 in		6000 mm/240 in		7500 mm/300 in				mm in
														
7500 mm 300 in	kg lb											*2550	*2550	4370
6000 mm 240 in	kg lb											*2100	*2100	5950
												*4,650	*4,650	240
4500 mm 180 in	kg lb							*3150 *6,900	2600 5,550			*2000 *4,350	*2000 *4,350	6860 270
3000 mm 120 in	kg lb					*3850 *8,400	*3850 8,350	*3450 *7,500	2500 5,400			*2000 *4,350	1800 4,000	7360 290
1500 mm 60 in	kg lb			*7550 *16,250	6600 14,150	*4900 *10,650	3600 7,800	3700 7,950	2400 5,150	*2150	1700	*2050 *4,550	1700 3,750	7520 300
0 mm 0 in	kg lb			*7850 *18,150	6150 13,150	5550 11,850	3400 7,350	3600 7,700	2300 4,950			*2300 *5,000	1700 3,750	7380 290
-1500 mm -60 in	kg lb	*4500 *10,050	*4500 *10,050	*9350 *20,200	6000 12,900	5400 11,600	3300 7,100	3550 7,600	2250 4,800			*2700 *5,900	1850 4,100	6910 280
-3000 mm -120 in	kg lb	*7500 *16,850	*7500 *16,850	*8550 *18,500	6050 13,000	5400 11,650	3300 7,100	3550	2250			3550 7,850	2250 5,000	6040 240
-4500 mm -180 in	kg lb			*6450 *13,700	6250 13,450	*4050	3450					*4000 *8,800	3450 7,800	4530 180



ISO 10567



*Indicates that the load is limited by hydraulic lifting capacity rather than tipping load. The above loads are in compliance with hydraulic excavator lift capacity standard ISO 10567:2007. They do not exceed 87% of hydraulic lifting capacity or 75% of tipping load. Weight of all lifting accessories must be deducted from the above lifting capacities. Lifting capacities are based on the machine standing on a firm, uniform supporting surface. The use of a work tool attachment point to handle/lift objects, could affect the machine lift performance.

Lift capacity stays with $\pm 5\%$ for all available track shoes.

Always refer to the appropriate Operation and Maintenance Manual for specific product information.

313D2 L Hydraulic Excavator Specifications

Reach Boom Lift Capacities – Counterweight: 2.65 mt (5,840 lb) – without Bucket

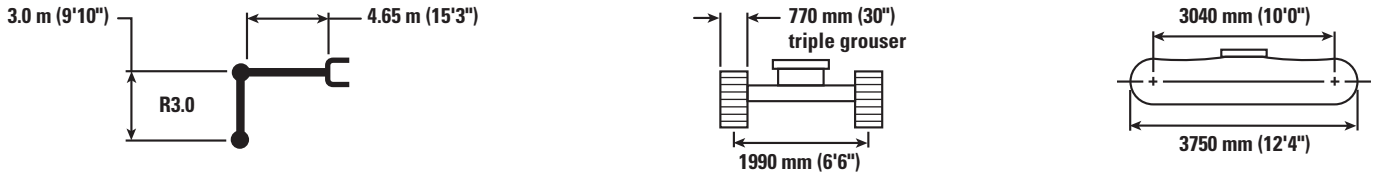

		1500 mm/60 in		3000 mm/120 in		4500 mm/180 in		6000 mm/240 in		7500 mm/300 in		mm in		
7500 mm 300 in	kg lb											*2550	*2550	4370
6000 mm 240 in	kg lb											*2100	*2100	5950
												*4,650	*4,650	240
4500 mm 180 in	kg lb							*3150 *6,900	2650 5,700			*2000 *4,350	*2000 *4,350	6860 270
3000 mm 120 in	kg lb					*3850 *8,400	*3850 *8,400	*3450 *7,500	2600 5,500			*2000 *4,350	1850 4,100	7360 290
1500 mm 60 in	kg lb			*7550 *16,250	6750 14,500	*4900 *10,650	3700 8,000	3800 8,200	2450 5,300	*2150	1750	*2050 *4,550	1750 3,850	7520 300
0 mm 0 in	kg lb			*7850 *18,150	6300 13,550	5700 12,200	3500 7,550	3700 7,950	2350 5,100			*2300 *5,000	1800 3,900	7380 290
-1500 mm -60 in	kg lb	*4500 *10,050	*4500 *10,050	*9350 *20,200	6200 13,250	5550 11,950	3400 7,300	3650 7,800	2300 4,950			*2700 *5,900	1950 4,200	6910 280
-3000 mm -120 in	kg lb	*7500 *16,850	*7500 *16,850	*8550 *18,500	6250 13,350	5600 11,950	3400 7,350	3650	2350			*3550 *7,950	2300 5,150	6040 240
-4500 mm -180 in	kg lb			*6450 *13,700	6450 *13,700	*4050	3550					*4000 *8,800	3550 8,000	4530 180



ISO 10567



*Indicates that the load is limited by hydraulic lifting capacity rather than tipping load. The above loads are in compliance with hydraulic excavator lift capacity standard ISO 10567:2007. They do not exceed 87% of hydraulic lifting capacity or 75% of tipping load. Weight of all lifting accessories must be deducted from the above lifting capacities. Lifting capacities are based on the machine standing on a firm, uniform supporting surface. The use of a work tool attachment point to handle/lift objects, could affect the machine lift performance.









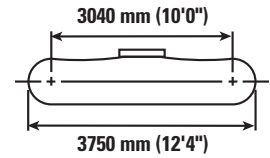
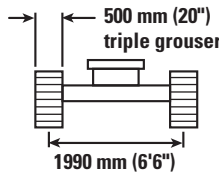
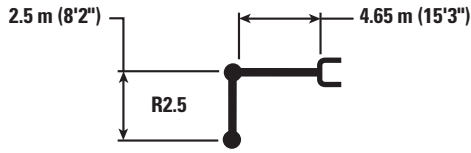

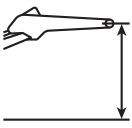

Lift capacity stays with $\pm 5\%$ for all available track shoes.

Always refer to the appropriate Operation and Maintenance Manual for specific product information.

313D2 L Hydraulic Excavator Specifications

Reach Boom Lift Capacities – Counterweight: 2.65 mt (5,840 lb) – without Bucket



		1500 mm/60 in		3000 mm/120 in		4500 mm/180 in		6000 mm/240 in				mm in
												
6000 mm 240 in	kg lb					*3350 *7,450	*3350 *7,450			*2450 *5,400	*2450 *5,400	5380 210
4500 mm 180 in	kg lb					*3550 *7,750	*3550 *7,750	*3500 *7,100	2500 5,400	*2250 *4,950	*2250 *4,950	6370 250
3000 mm 120 in	kg lb			*5850 *12,500	*5850 *12,500	*4350 *9,400	3750 8,100	3750 8,050	2450 5,250	*2250 *4,900	1950 4,350	6900 280
1500 mm 60 in	kg lb			*8450 *18,100	6350 13,650	*5300 *11,500	3550 7,600	3650 7,800	2350 5,050	*2350 *5,100	1850 4,050	7080 280
0 mm 0 in	kg lb			*6900 *15,900	6050 12,950	5450 11,700	3350 7,250	3550 7,650	2300 4,900	*2600 *5,650	1900 4,100	6930 280
-1500 mm -60 in	kg lb	*4850 *10,900	*4850 *10,900	*9200 *20,000	6000 12,850	5350 11,550	3300 7,100	3500 7,550	2250 4,850	*3100 *6,800	2050 4,550	6430 260
-3000 mm -120 in	kg lb	*8750 *19,750	*8750 *19,750	*8100 *17,400	6100 13,050	5400 11,600	3350 7,200			4050 9,050	2600 5,750	5480 220



ISO 10567



*Indicates that the load is limited by hydraulic lifting capacity rather than tipping load. The above loads are in compliance with hydraulic excavator lift capacity standard ISO 10567:2007. They do not exceed 87% of hydraulic lifting capacity or 75% of tipping load. Weight of all lifting accessories must be deducted from the above lifting capacities. Lifting capacities are based on the machine standing on a firm, uniform supporting surface. The use of a work tool attachment point to handle/lift objects, could affect the machine lift performance.









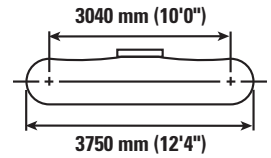
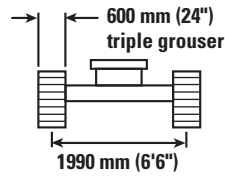
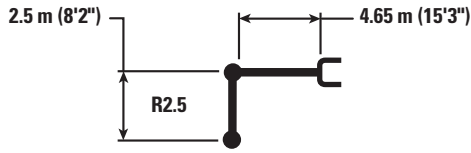

Lift capacity stays with $\pm 5\%$ for all available track shoes.

Always refer to the appropriate Operation and Maintenance Manual for specific product information.

313D2 L Hydraulic Excavator Specifications

Reach Boom Lift Capacities – Counterweight: 2.65 mt (5,840 lb) – without Bucket



		1500 mm/60 in		3000 mm/120 in		4500 mm/180 in		6000 mm/240 in				mm in
												
6000 mm 240 in	kg lb					*3350 *7,450	*3350 *7,450			*2450 *5,400	*2450 *5,400	5380 210
4500 mm 180 in	kg lb					*3550 *7,750	*3550 *7,750	*3500 *7,100	2550 5,450	*2250 *4,950	*2250 *4,950	6370 250
3000 mm 120 in	kg lb			*5850 *12,500	*5850 *12,500	*4350 *9,400	3850 8,250	*3750 8,150	2500 5,350	*2250 *4,900	2000 4,400	6900 280
1500 mm 60 in	kg lb			*8450 *18,100	6450 13,850	*5300 *11,500	3600 7,750	3700 7,950	2400 5,150	*2350 *5,100	1900 4,150	7080 280
0 mm 0 in	kg lb			*6900 *15,900	6150 13,200	5550 11,900	3450 7,350	3600 7,750	2350 5,000	*2600 *5,650	1900 4,200	6930 280
-1500 mm -60 in	kg lb	*4850 *10,900	*4850 *10,900	*9200 *20,000	6100 13,100	5450 11,750	3350 7,250	3600 7,700	2300 4,950	*3100 *6,800	2100 4,650	6430 260
-3000 mm -120 in	kg lb	*8750 *19,750	*8750 *19,750	*8100 *17,400	6200 13,300	*5500 *11,800	3400 7,300			4150 9,200	2650 5,850	5480 220



ISO 10567



*Indicates that the load is limited by hydraulic lifting capacity rather than tipping load. The above loads are in compliance with hydraulic excavator lift capacity standard ISO 10567:2007. They do not exceed 87% of hydraulic lifting capacity or 75% of tipping load. Weight of all lifting accessories must be deducted from the above lifting capacities. Lifting capacities are based on the machine standing on a firm, uniform supporting surface. The use of a work tool attachment point to handle/lift objects, could affect the machine lift performance.









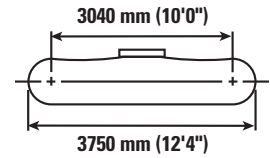
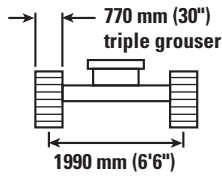
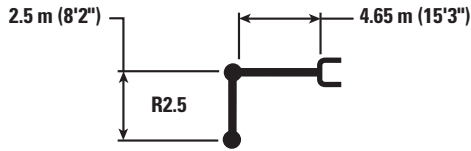

Lift capacity stays with ±5% for all available track shoes.

Always refer to the appropriate Operation and Maintenance Manual for specific product information.

313D2 L Hydraulic Excavator Specifications

Reach Boom Lift Capacities – Counterweight: 2.65 mt (5,840 lb) – without Bucket



		1500 mm/60 in		3000 mm/120 in		4500 mm/180 in		6000 mm/240 in				mm in
												
6000 mm 240 in	kg lb					*3350 *7,450	*3350 *7,450			*2450 *5,400	*2450 *5,400	5380 210
4500 mm 180 in	kg lb					*3550 *7,750	*3550 *7,750	*3500 *7,100	2650 5,600	*2250 *4,950	*2250 *4,950	6370 250
3000 mm 120 in	kg lb			*5850 *12,500	*5850 *12,500	*4350 *9,400	3950 8,450	*3750 *8,200	2550 5,500	*2250 *4,900	2050 4,550	6900 280
1500 mm 60 in	kg lb			*8450 *18,100	6600 14,250	*5300 *11,500	3700 7,950	3800 8,200	2450 5,300	*2350 *5,100	1950 4,250	7080 280
0 mm 0 in	kg lb			*6900 *15,900	6300 13,550	5700 12,250	3550 7,600	3700 8,000	2400 5,150	*2600 *5,650	1950 4,300	6930 280
-1500 mm -60 in	kg lb	*4850 *10,900	*4850 *10,900	*9200 *20,000	6250 13,450	5650 12,050	3450 7,450	3700 7,950	2350 5,100	*3100 *6,800	2150 4,750	6430 260
-3000 mm -120 in	kg lb	*8750 *19,750	*8750 *19,750	*8100 *17,400	6350 13,650	*5500 *11,800	3500 7,500			*4200 *9,200	2700 6,000	5480 220



ISO 10567



*Indicates that the load is limited by hydraulic lifting capacity rather than tipping load. The above loads are in compliance with hydraulic excavator lift capacity standard ISO 10567:2007. They do not exceed 87% of hydraulic lifting capacity or 75% of tipping load. Weight of all lifting accessories must be deducted from the above lifting capacities. Lifting capacities are based on the machine standing on a firm, uniform supporting surface. The use of a work tool attachment point to handle/lift objects, could affect the machine lift performance.

Lift capacity stays with ±5% for all available track shoes.

Always refer to the appropriate Operation and Maintenance Manual for specific product information.

313D2 L Standard Equipment

Standard Equipment

Standard equipment may vary. Consult your Cat dealer for details.

ENGINE

- Diesel engine – Cat C4.4 with mechanical governor
 - 2300 m (7,546 ft) altitude capability
 - 50 amp alternator, air intake heater
 - Meets Tier 3, Stage IIIA, Japan 2006 (Tier 3) equivalent and China Nonroad Stage III emission standards
- 10 micron fuel filter
- 4 micron fuel pre-filter
- One touch low idle with AEC
- Remote engine oil filter
- Radial seal air filter, double element
- Two speed travel
- Water separator in fuel line with indicator
- Waved fin radiator with side by side type oil cooler
- Fix type A/C condenser
- 46° C (114.8° F) High ambient cooling
- Air precleaner

CAB

- Bolt-on FOGS capability
- Openable front windshield with assist device
- Pillar mounted upper windshield wiper and washer
- Front windshield glass split by 70/30
- Cab sliding upper door window
- Rear window, emergency exit
- Removable lower windshield with in cab storage bracket
- Metal hatch
- Interior lighting
- Standard joystick
- Laminated front upper windshield
- Seat high back, mechanical suspension with head rest

- Seat belt, retractable
- Floor mat
- Bi-level air conditioner (auto) with defroster
- Windshield washer
- Coat hook
- Ashtray and lighter
- Beverage holder
- Literature holder
- Radio mounting
- Mounting for two stereo speakers
- Antenna flexible type
- Storage compartment suitable for lunch box
- Monitor
 - Language display
 - Full graphic and full color display
 - Warning information
 - Filter/fluid change information
 - Machine condition
 - Error code and tool mode setting information
 - Full time clock on monitor
- Positive filtered ventilation
- Seat integrated control joystick
- Adjustable armrest
- Adjustable console
- Neutral lever (lock out) for all controls
- Travel control pedals with removable hand levers
- Capability of installing two additional pedals

ELECTRICAL

- Circuit breaker
- Cat battery

TECHNOLOGY

- Product Link™

HYDRAULIC

- Hydraulic main pump
- High performance hydraulic return filter
- Regeneration control for boom and stick
- Boom lowering device for back up
- Boom drift reducing valve
- Stick drift reducing valve
- Reverse swing damping valve
- Automatic swing parking brake
- Auxiliary hydraulic valve
- Capability of stackable valves for main valve
- Capability of auxiliary circuit

SECURITY

- Cat one key security system
- Signaling/warning horn
- Mirrors, rearview (frame – right, cab – left)
- Secondary engine shutoff switch
- Door locks
- Cap locks on fuel and hydraulic tanks
- Lockable external tool/storage box
- Openable skylight for emergency exit

LIGHTS

- Halogen boom light (left side)
- Exterior lights integrated into storage box

UNDERCARRIAGE

- Grease lubricated track (GLT2)
- Idler section track guiding guard
- Towing eye on base frame
- Standard idler tension spring
- Guard, standard bottom

Optional Equipment

Optional equipment may vary. Consult your Cat dealer for details.

ENGINE

- Cold weather batteries, -25° C (-13° F)
- Air precleaner

HYDRAULIC

- Combined circuit
- Combined circuit with medium pressure
- Cat pin grabber coupler lines and control
- Joystick with modulation SW
- Boom and Stick high pressure, medium pressure and quick coupler line options
- Control pattern quick-changer, four way

CAB

- Seat with seat heater, high back, air suspension with head rest
- Pull-down sunscreen
- 12V-10A power supply with two cigar lighter type sockets

UNDERCARRIAGE

- 500 mm (20") triple grouser shoes
- 600 mm (24") triple grouser shoes
- 770 mm (30") triple grouser shoes

COUNTERWEIGHT

- Counterweight without lifting eye (2450 kg/5,400 lb)
- Counterweight without lifting eye (2650 kg/5,840 lb)

FRONT LINKAGE

- Boom, 4.65 m (15'3")
- Stick, 2.5 m (8'2")
- Stick, 3.0 m (9'10")
- Bucket linkage
- Quick coupler

LIGHTS

- Cab lights
- Halogen boom light (right side)

SECURITY

- Travel alarm
- Cab mirror

GUARDS

- FOGS (bolt on)
- Guard, heavy duty bottom
- Swivel guard

For more complete information on Cat products, dealer services, and industry solutions, visit us on the web at www.cat.com

© 2017 Caterpillar
All rights reserved

Materials and specifications are subject to change without notice. Featured machines in photos may include additional equipment. See your Cat dealer for available options.

CAT, CATERPILLAR, SAFETY.CAT.COM, their respective logos, "Caterpillar Yellow" and the "Power Edge" trade dress, as well as corporate and product identity used herein, are trademarks of Caterpillar and may not be used without permission.

AEHQ7894-01
Replaces AEHQ7894
(AME, CIS, LACD)

