

AP300F, AP355F

Pavers



Cat® C3.3B Engine

Gross Power (SAE J1995) 55.5 kW 73.8 hp 74.8 metric hp

Operating Weight

	AP300F	AP355F
Tractor only	6600 kg (14,550 lb)	7100 kg (15,653 lb)
w/SE34 V Screed	8000 kg (17,637 lb)	8500 kg (18,739 lb)
w/SE34 VT Screed	8200 kg (18,078 lb)	8700 kg (19,180 lb)

Paving Widths

	1.75 m - 3.42 m	5' 9" - 11' 2"
Standard Extendable Range		
Maximum w/Extensions		
AP300F	4.0 m	13' 1"
AP355F	4.6 m	15' 1"
Paving Reduction Attachment	700 mm	27.5"

VERSATILE PAVING CAPABILITY IN A HIGHLY PRODUCTIVE MACHINE

The AP300F and AP355F pavers combine excellent styling with technology that exemplifies our commitment to increased comfort and productivity. Operators will appreciate the numerous technological enhancements as they navigate around the twists and turns of urban environments and mountain roads.

What the crews will also quickly discover is the excellent mat quality produced by the new SE34 V and SE34 VT screeds.

Easy installation and removal of extension packages make this machine a perfect combination of productivity and versatility.

A comfortable operating environment with dual seats that can be easily positioned outside of the machine frame optimizes visibility.

These models are a great fit for city streets, rural roads, town centers, parkways, and general maintenance and repair applications.

CONTENTS

Features	2
Machine Overview	3
Cat C3.3B Engine	4
Smooth Delivery	5
Operating Environment	6
Simple Operation	7
Wheel Undercarriage	8
Mobil-Trac™ Undercarriage	9
AP300F Specifications	10
AP355F Specifications	11

FEATURES

MULTI-PURPOSE, EXTREMELY MANEUVERABLE PAVER.

TECHNOLOGICALLY ADVANCED

- Engine options available to meet U.S. EPA Tier 4 Final, EU Stage IIIB emissions and other regional standards
- One-touch hopper control
- Single-touch feeder system activation
- Auto-fill feeder system
- Mobil-trac undercarriage delivers fast travel and smooth ride (AP355F)
- Product Link™ capability,

QUALITY PAVING, HIGHER EARNINGS

- Tamper-bar with vibration, or vibration only screeds
- Hydraulically extendible from 1.75 m to 3.42 m (5' 9" to 11' 2")
- Maximum with mechanical bolt-on extensions
 - 4.0 m (13' 1") – AP300F
 - 4.6 m (15' 1") – AP355F
- Hydraulic paving reduction attachment narrows the paving width to 700 mm (27.5")

LOW OWNING AND OPERATING COSTS

- Exclusive Advanced Eco-mode reduces fuel consumption and lowers sound levels for better comfort and communication
- Million cycle switches provide reliability
- Conveyor bed plates and chain guards designed to minimize labor requirements and provide lower cost replacement
- Heating elements slide-out for easy replacement
- Machined screed frames simplify screed plate leveling

UNMATCHED AFTER-THE-SALE SUPPORT

- Strategically located dealers with 24/7 support
- In-the-Iron service training for technicians
- Paver Operator Training helps maximize machine performance
- Project consulting helps improve technique and job site management

PRODUCTIVITY FEATURES

1. Advanced Eco-mode
2. Auto-Fill System
3. Single-Touch Feeder System
4. Touch-Screen Display, and Push-Button Controls
5. Mobil-Trac Undercarriage - AP355F
6. Cat C3.3B Engine
7. Front-Wheel Assist Option - AP300F
8. SE34 V Vibration only and SE34 VT Tamper Bar Screens



CAT C3.3B ENGINE

RELIABLE, QUIET, POWERFUL.

Reduced FUEL CONSUMPTION and Lower SOUND LEVELS

Don't waste fuel or power, Advanced Eco-mode optimizes engine speed and delivers the power when needed.

Eco-mode

- Eco-mode, utilizes an engine speed of 1900 rpm for reduced fuel consumption and lower sound levels
- Well suited for most applications

Automatic Engine Speed Control (Canada, Europe, and U.S. only)

- Engine operates at 2200 rpm when the propel lever moves from neutral
- When activated, engine speed is reduced to idle speed of 1200 rpm when the propel lever is moved to neutral or to 1500 rpm when screed heat is active

Advanced Eco-mode (Canada, Europe, and U.S. only)

- Combines Eco-mode and Automatic Engine Speed Control
- Engine speed increases to 1900 rpm when the propel lever moves from neutral
- Modifies engine speed based on load
- If the upper power threshold is exceeded, the engine speed will increase to 2200 rpm and remain there until the load drops below the minimum threshold and remains there for 30 seconds



CAT C3.3B ENGINE

C3.3B engine models are available to meet regional emissions, including U.S. EPA Tier 4 Final and EU Stage IIIB.





AUTOMATION

CONTINUOUS MATERIAL FLOW, BETTER MAT QUALITY.

EASY OPERATION

Auto-Fill Feeder System

- Simplifies starts by filling the auger chamber to the height of the sensor set point

Single-Touch Feeder System

- Automatically activates the entire feeder system with a single button for better efficiency

One-Touch Hopper Control

- The hopper wings can be folded with a single touch and release
- The system can be tailored to activate left or right wings together or independently

Cleanout/Warmup Mode

- Activates the augers, conveyors, and tamper bar (if equipped) in slow speed, enables the application of release agents to prevent material build-up

Mix Height Adjustment

- Mix height adjustment from the tractor touch-screen display offers more control, previously only available from the screed

SMOOTH FLOW

- Narrow chain guards and optimally spaced flight bars promote smooth mix flow
- 3.8 m³ (134 ft³) hopper capacity delivers productivity when truck delivery isn't possible
- Wide hopper width of 3180 mm (10' 5") enables smooth truck delivery
- Truck discharge height of 570 mm (22") and adjustable push-roller easily accept a variety of trucking fleets



OPERATING ENVIRONMENT

OPERATE WITH CONFIDENCE.

BETTER VISIBILITY

- Dual independent seating can extend beyond the frame for good all-around visibility, also offer backup capability
- Low profile front-mounted cooling system improves forward visibility
- The auger assembly has been redesigned to improve visibility into the auger chamber
- 12-volt power receptacle, supports communication devices
- Upper and lower tow-point indicators simplify height adjustment for tractor and screed operators

MORE COMFORT

- Operator-friendly environment
- Cooling system helps redirect the fumes surge that occurs when mix is dumped into the hopper
- Ventilation system removes and redirects vapors from the conveyor tunnels and auger chamber and redirects them towards the hopper, away from tractor and screed operators

EASY RECOGNITION

- Multiple language options
- Intuitive symbols and large graphics simplify operation
- Adjustable brightness control for easy viewing day or night
- Raised switch design enables easy recognition for better efficiency and performance

INTERACTIVE LCD DISPLAY

- Touch-screen access to:
 - Generator activation
 - Screed temperature control
 - Tamper and vibratory speeds
 - Mix height adjustment, *previously only available from the screed console*
 - Service code information
 - Screed heating zones
 - Stored operator preferences

SIMPLE OPERATION

USER-FRIENDLY TECHNOLOGY
ENHANCES CONTROL.



TOP FEATURES

1. Automated Hopper Functions
2. New Mix Delivery Technology
3. Million Cycle Switches
4. Water Resistant Console and Touch-Screen Display
5. Generator Activation
6. Day or Night Brightness Control
7. Eco-Mode and Automatic Engine Speed Control

WHEEL UNDERCARRIAGE

EXCELLENT TRACTION AND DURABILITY.



EXCELLENT MANEUVERABILITY

- Two, 365/80 R20 hydro-flated drive tyres
- Four 455 mm x 260 mm, solid rubber steering wheels
- Tight outside turning radius for quick mobility
- Quick reacting speed control ensures responsive power
- High flotation delivers excellent performance on soft base applications
- The oscillating front bogie design easily overcomes obstacles, eliminates jarring effects and minimizes tow-point movement

The wheel undercarriage offers quick reacting speed control, responsive power, and high speed capability when moving around the job site.

MOBILITY

- Hydrostatic propel system
- Pave, Travel and Maneuver modes
 - Pave: Improved steering control when paving
 - Travel: Speeds of 0-16 km/hr (0-10 mph)
 - Maneuver: Optimizes steering control and delivers an outside turning radius of 1.65 m (5' 5")

FRONT WHEEL ASSIST (OPTION)

- Front wheel assist option provides added traction when pushing trucks or working on soft base

EXCELLENT TRACTION

HIGH SPEEDS

MOBIL-TRAC DELIVERS RIDE SIMILAR TO WHEELED PAVERS.

MOBILITY

- High speed capability; similar to wheeled pavers
- Pave, Travel and Maneuver modes
 - Pave: Improved steering control when paving
 - Travel: Maximum speeds
 - Maneuver: Optimizes steering control and enables the paver to rotate within its own footprint

SMOOTH RIDE

- Oscillating bogie design delivers ride similar to wheeled paver
- Pivoting design eliminates jarring effects caused by milled cuts
- Guide lugs keep the tracks centered for reliable performance

PERFORMANCE

- Mobil-Trac undercarriage design minimizes tow-point movement
- Front and rear bogie sets crawl over obstacles; maintain ground contact and minimize tow-point movement
- Smooth belt performs well on soft base materials and fresh mats
- Outstanding traction in any condition
- Excellent flotation and low ground pressures due to the large track area

DURABILITY

- Self-tensioning accumulators, center guide blocks and rugged internal belt cables ensure durability
- Rubber-coated components designed to shed asphalt and prevent accumulation



AP300F SPECIFICATIONS

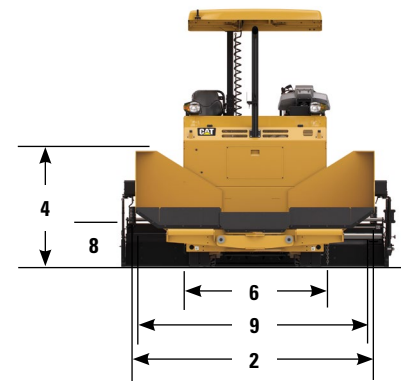
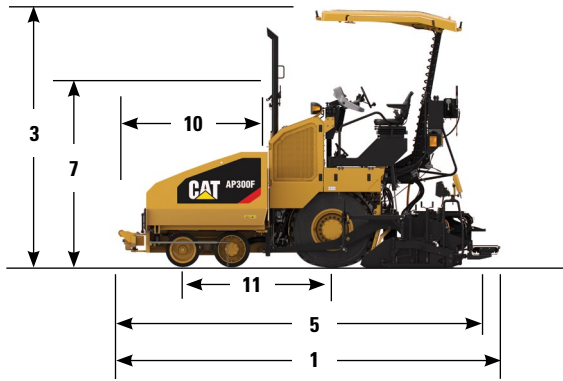

Dimensions

1	Operating length w/screed	5047 mm	16' 6"
2	Operating width	3180 mm	10' 5"
3	Operating height	3415 mm	11' 2"
4	Operating deck height	1313 mm	4' 3"
5	Transport length	4904 mm	16' 1"
6	Transport width w/endgates	1886 mm	6' 2"
7	Transport height - canopy retracted	2645 mm	8' 8"
8	Truck entry height	547 mm	21.5"
9	Truck entry width	3150 mm	10' 4"
10	Hopper length w/push-roller	1993 mm	6' 4"
11	Wheelbase	1987 mm	6' 6"

Powertrain

Cat C3.3B Engine*	55 kW	74.8 hp (M)	73.8 hp (I)
* Engine options are available in order to meet U.S. EPA Tier 4 Final, EU Stage IIIB, or emissions equivalent to U.S. EPA Tier 3, EU Stage IIIA, China Off-Road Stage III, U.S. EPA Tier 2 and EU Stage II.			
Number of Cylinders	4		
Engine speed	2200/1000 rpm		
Eco-mode	1900 rpm		
Speed ranges			
Paving - vibratory screed	61 mpm	200 fpm	
Paving - tamper-bar screed	25 mpm	82 fpm	
Travel	16 km/hr	10 mph	
Steering			
Outside Turning Radius	1.65 m	5' 5"	
Manuever mode	500 mm	20"	

Weights

AP300F Paver only - shipping	6600 kg	14,550 lb
AP300F Paver w/SE34 V Screed	8000 kg	17,637 lb
AP300F Paver w/SE34 VT Screed	8200 kg	18,078 lb

Paving Specifications

Standard paving range	1.75 - 3.42 m	5' 9"-11' 2"
Maximum paving width	4.0 m	13' 1"
Reduction Attachment	700 mm	27.5"
Screed Vibration Frequency	50 Hz	3000 vpm
Screed Tamper Bar Frequency	30 Hz	1800 vpm
Screed Crown Adjustment	+4.5% to -2.5%	

Capacities

Maximum throughput capacity	504 tonnes/h	555 tph
Hopper capacity with tunnels	3.8 m ³	134 ft ³
Fuel tank	110 L	29 gal
Engine oil	13.2 L	3.5 gal
Cooling system	9 L	2.4 gal
Hydraulic tank	80 L	17.6 gal
Washdown Spray Tank	28 L	6.2 gal

AP355F SPECIFICATIONS

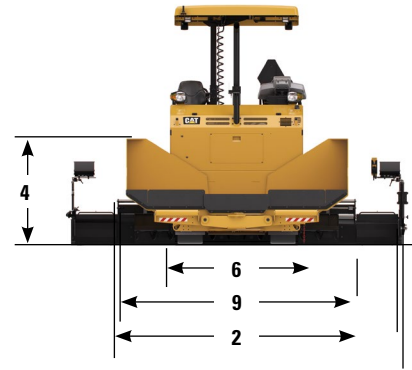
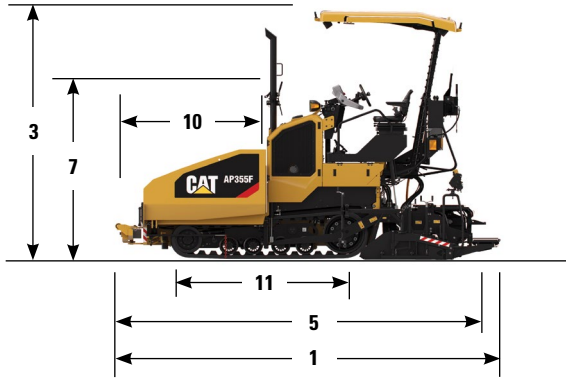

Dimensions

1 Operating length w/screed	5047 mm	16' 6"
2 Operating width	3180 mm	10' 5"
3 Operating height	3415 mm	11' 2"
4 Operating deck height	1313 mm	4' 3"
5 Transport length	4904 mm	16' 1"
6 Transport width w/endgates	1886 mm	6' 2"
7 Transport height - canopy retracted	2645 mm	8' 8"
8 Truck entry height	547 mm	21.5"
9 Truck entry width	3150 mm	10' 4"
10 Hopper length w/push-roller	1993 mm	6' 4"
11 Ground Contact Length	2055 mm	6' 9"

Powertrain

Cat C3.3B Engine*	55 kW	74.8 hp (M)	73.8 hp (I)
* Engine options are available in order to meet U.S. EPA Tier 4 Final, EU Stage IIIB, or emissions equivalent to U.S. EPA Tier 3, EU Stage IIIA, China Off-Road Stage III, U.S. EPA Tier 2 and EU Stage II.			
Number of Cylinders	4		
Engine speed	2200/1000 rpm		
Eco-mode	1900 rpm		
Speed ranges			
Paving	64 mpm	210 fpm	
Paving - tamper-bar screed	25 mpm	82 fpm	
Travel	11 km/hr	7 mph	
Steering			
Outside Turning Radius	1.65 m	5' 5"	
Manuever mode	500 mm	20"	

Weights

AP355F Paver only - shipping	7100 kg	15,652 lb
AP355F Paver w/SE34 V Screed	8500 kg	18,739 lb
AP355F Paver w/SE34 VT Screed	8700 kg	19,180 lb

Paving Specifications

Standard paving range	1.75 - 3.42 m	5' 9"-11' 2"
Maximum paving width	4.6 m	15' 1"
Reduction Attachment	700 mm	27.5"
Screed Vibration Frequency	50 Hz	3000 vpm
Screed Tamper Bar Frequency	30 Hz	1800 vpm
Screed Crown Adjustment	+4.5% to -2.5%	

Capacities

Maximum throughput capacity	504 tonnes/h	555 tph
Hopper capacity with tunnels	3.8 m ³	134 ft ³
Fuel tank	110 L	29 gal
Engine oil	13.2 L	3.5 gal
Cooling system	9 L	2.4 gal
Hydraulic tank	80 L	17.6 gal
Washdown Spray Tank	28 L	6.2 gal

AP300F and AP355F Pavers

For more complete information on Cat products, dealer services, and industry solutions, visit us on the web at www.cat.com

QEHQ1930-02 (07/16)

©2016 Caterpillar Inc. All rights reserved

Materials and specifications are subject to change without notice. Featured machines in photos may include additional equipment. See your Cat dealer for available options.

CAT, CATERPILLAR, SAFETY.CAT.COM, their respective logos, "CaterpillarYellow" and the "PowerEdge" trade dress, as well as corporate and product identity used herein, are trademarks of Caterpillar and may not be used without permission.

