

# **Application & Installation Guide**

## **Crankcase Ventilation Systems**

**LEBW4958-04**





# Contents

- Crankcase Ventilation Systems ..... 1**
- Crankcase Emissions ..... 2
- Blow-by ..... 2
- Crankcase Ventilation ..... 3
- Ingestive ..... 3
- Low Pressure Ingestive System ..... 3
- High Pressure Ingestive System ..... 4
- Introducing Fresh Air into Crankcase ..... 5
- Water in Engine Oil ..... 5
- Crankcase Pressure ..... 5
- Non-Ingestive ..... 6
- Diluting Crankcase Emissions ..... 11
- Reference Material ..... 12







# Crankcase Ventilation Systems

Crankcase ventilation systems are designed to control the balance of air pressure between the engine crankcase and atmospheric pressure while processing the accompanying fumes.

Crankcase air pressures that are excessively above or below atmospheric pressure can have negative affects on component life, the lubricating oil system and overall engine emissions.

Ventilating the engine crankcase is not a difficult process in itself. Controlling emissions and preventing contamination, however, add some complexity to this system.

## SECTION CONTENTS

<b>Crankcase Emissions .....</b>	<b>2</b>	<b>Measuring Blow-by.....</b>	<b>11</b>
• Sources		• Step-by-step instructions	
• Harmful Effects			
• Composition			
<b>Crankcase Ventilation.....</b>	<b>3</b>		
• Ingestive			
• Non-Ingestive			

---

---

## Crankcase Emissions

### Blow-by

Crankcase emissions result from combustion byproducts and/or exhaust fumes escaping around the piston rings and into the crankcase. These escaping fumes are commonly called blow-by. If not controlled, the blow-by can contaminate the lubricating oil and pressurize the crankcase, possibly leading to an oil leak.

The overall volume of blow-by varies due to cylinder pressure, piston ring pressure and component wear.

Venting the emissions to the atmosphere is a simple solution to release the pressure and trapped fumes. Managing the emissions, however, adds complexity to crankcase ventilation systems.

Elements found in blow-by can include wear particles, oil, fuel, gas and air. The specific composition of the elements varies due to fuel type, engine type, engine speed, load and maintenance history. Typically, blow-by is made up of hydrocarbons (HC), carbon monoxide (CO), carbon dioxide (CO<sub>2</sub>), nitrogen oxides (NO<sub>x</sub>), water

vapor and traces of sulfates and aldehydes.

Crankcase hydrocarbon emissions are normally 3% of the total exhaust emissions tested at the mid-life of the engines. However, due to piston ring tolerances, crankcase hydrocarbon emissions can increase to 20% of the total hydrocarbon emissions.

The amount of NO<sub>x</sub> present in the blow-by decreases depending on the air/fuel ratio of the engine. As the air/fuel mixture becomes leaner, less NO<sub>x</sub> should be present.

The sulfates and aldehydes will change depending on the fuel. An engine running on diesel fuel, landfill gas or digester gas will have more sulfides present in the blow-by than an engine running on natural gas.

As emission laws become more stringent, it is inevitable that crankcase emissions will be included in total system emission values. Certain parts of Europe and California are already counting blow-by in the emission numbers. In the future, ventilating crankcase emissions to the atmosphere will be discouraged or prohibited.



## Crankcase Ventilation

Crankcase ventilation systems can be classified as either ingestive or non-ingestive. An ingestive system vents the blow-by into the engine where it returns to the combustion process. A non-ingestive system vents blow-by to the atmosphere.

Except for some marine pleasure craft applications, Caterpillar does not offer ingestive crankcase ventilation systems on diesel engines.

### Ingestive

The ingestive crankcase ventilation system routes any crankcase emissions into the intake air stream, where it is re-burned in the combustion process.

This system is known as Positive Crankcase Ventilation (PCV) in the automobile industry. PCV is economical and efficient in automobiles because most are naturally aspirated and do not have sophisticated air handling components found on industrial engines. Turbocharging and other intake air handling components can be negatively affected by blow-by fumes. This creates additional challenges when using a PCV-type system on an industrial engine.

There are two ways of re-introducing blow-by fumes back into the combustion process on a turbocharged engine. The blow-by can be put in the system at low pressure (before the turbocharger) or at high pressure (after the turbocharger).

#### Low Pressure Ingestive System

A low pressure, ingestive system involves piping the crankcase emissions into the low pressure side of the turbocharger.

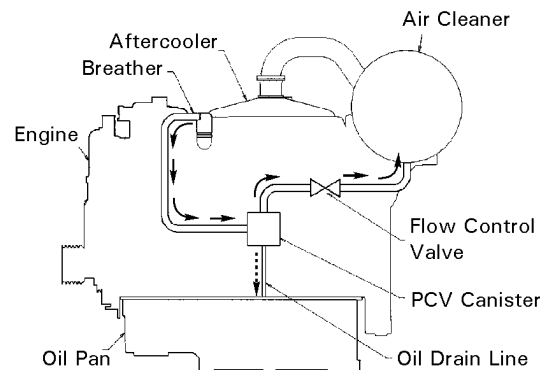

**Figure 1**

As shown in **Figure 1**, the blow-by flows from the crankcase through vent tubes, through an oil condensing device (or blow-by filter) and is drawn through the air cleaner by the turbocharger.

There are a number of threats that can occur when using an ingestive system on a turbocharged engine. These threats include:

- Reduced spark plug life in gas engines
- Fouled or damaged turbocharger or aftercooler
- Reduced detonation margin, engine detonation, damaged pistons in gas engines
- Reduced load capability and operation
- Reduced efficiency
- Reduced component life

In addition, most tests have shown that no matter how effective the blow-by filter, over time, enough oil will be adsorbed to coat the aftercooler. This oil will act as an insulator, reducing the cooling capabilities of the aftercooler.

Despite these drawbacks, demand for these systems has lead Caterpillar to offer an optional low pressure, ingestive, PCV system on the G3520C engine (Natural GAS engine only). When using this system, it is recommended that all operation and maintenance procedures are strictly followed. Higher maintenance cost should also be expected (this system is not for use in landfill applications or applications with corrosive fuels).

If a system not supplied by Caterpillar is used, extreme care should be observed to make sure the system design complies with the following list of recommendations for designing a low pressure, ingestive system.

- A cleanable aftercooler should be used and it should be cleaned regularly.
- The blow-by **must** be sent through a filtering system prior to entering the turbocharger.
- The system must be protected from freezing in low ambient temperature conditions.
- The system must ensure the draw on the crankcase does not exceed acceptable levels. This may be accomplished by installing a pressure relief valve between the turbocharger and the filtering system.
- Blow-by filters should be replaced or cleaned at every oil change.
- The system must be designed to handle two times the engine blow-by

measurements to account for normal engine wear.

- A minimum oil removal rate of 99.97% is required. Oil removal rate can be calculated as follows:

$$\% \text{ Removal} = \frac{\text{Blow-by Concentration (before PCV)} - \text{(after PCV)}}{\text{Blow-by Concentration before PCV}}$$

- Caterpillar recommends that the oil should NOT be returned to the crankcase for a non-approved system. If oil is planned to be returned to the crankcase, trend S•O•S<sup>SM</sup> samples of recovered oil every 100 hours of engine operation up to 800 hours to certify that the recovered oil does not reach condemning limits. If oil exceeds condemning limits, DO NOT return oil to the crankcase.
- The system must have a bypass to eliminate the possibility of crankcase over pressurization if the filter element clogs. Alarms for pressure differential are not supplied by Caterpillar.

### High Pressure Ingestive System

A high pressure ingestive crankcase ventilation system involves removing the blow-by from the crankcase and pumping it directly into the intake plenum as shown in **Figure 2**.

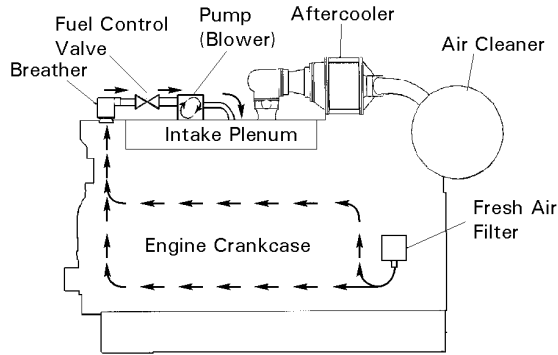

**Figure 2**

Although this type of system removes the risk of coating the aftercooler and turbocharger with oil, emissions should still be filtered to reduce the amount of oil going into the intake stream.

The limiting factor of this type of system is cost. The additional pump required for this system can be expensive and difficult to mount.

### Introducing Fresh Air into Crankcase

Removing blow-by out of the crankcase may not be enough to ensure an emission free crankcase environment. It may be necessary to add fresh air directly into the crankcase in order to dilute the air inside the crankcase. The amount of air should be about two times the volumetric flow rate of the blow-by.

In addition to filtering the air to prevent contamination, cold air may need to be heated to reduce the possibility of water condensing from the existing crankcase fumes.

### Water in Engine Oil

Crankcase emissions are essentially concentrated exhaust fumes; therefore, they contain a considerable amount of water vapor. When oil is separated from the blow-by and filtered back into the oil sump, there is the risk of water condensing. Because Diesel and

Natural Gas Engines have a considerable amount of water in their exhaust, many PCV suppliers are recommending that the excess oil be drained into a separate container.

When water is introduced to the engine oil, it forms an emulsion that clogs oil filters. As the amount of water increases, the ability for the additives to disperse the water in the oil decreases. The heat of the oil usually burns off water particles, but condensed blow-by contains so much water that the water can actually cool the oil and form sludge. Cooler oil temperatures may cause water and oil to combine to form dangerous acids that can corrode metals, thus reducing the lubricating qualities of the oil.

### Crankcase Pressure

The conventional wisdom of internal combustion engines is that the engine should operate at a slight positive pressure to prevent any surrounding contaminants from being drawn into the engine. However, the effect of a high-pressure ingestive ventilation system tends to create a slight vacuum. As long as this vacuum does not exceed 0.25 kPa (1 in. H<sub>2</sub>O), it is acceptable when considering the benefits of emissions removal from the crankcase.

Crankcase pressures should not vary more than 25.4 mm H<sub>2</sub>O (1.0 in. H<sub>2</sub>O) from the ambient barometric pressure for G3300, G3400 and G3500 engines. Some of the engines that monitor crankcase pressure will shutdown if excessive vacuum is sensed.

Restrictions higher than the limit on passive systems will encourage oil leaks. A powered system should

draw no more than a 25.4 mm H<sub>2</sub>O (1.0 in. H<sub>2</sub>O) vacuum, or dirt and dust could be drawn into the engine past the main seals. Measurement should be made at the engine dipstick location with the engine at operating temperature, speed, and load.

### Non-Ingestive

In regions that do not include crankcase emissions as part of the total emissions for an engine, a non-ingestive crankcase ventilation system is an acceptable solution. In some situations customers can reduce cost and potential engine

threats by venting the blow-by to the atmosphere. **Figure 3** shows a typical non-ingestive crankcase vent arrangement.

One of the goals of a PCV system is to increase the oil life of the engine. The removal of crankcase emissions can reduce the amount of oil degradation. It has been shown that a non-ingestive PCV system can double the oil life of an engine. However, the affects of PCV on oil life will vary with engine size, load, engine hours and ambient conditions.

### Typical Non-Ingestive Crankcase Ventilation Arrangement

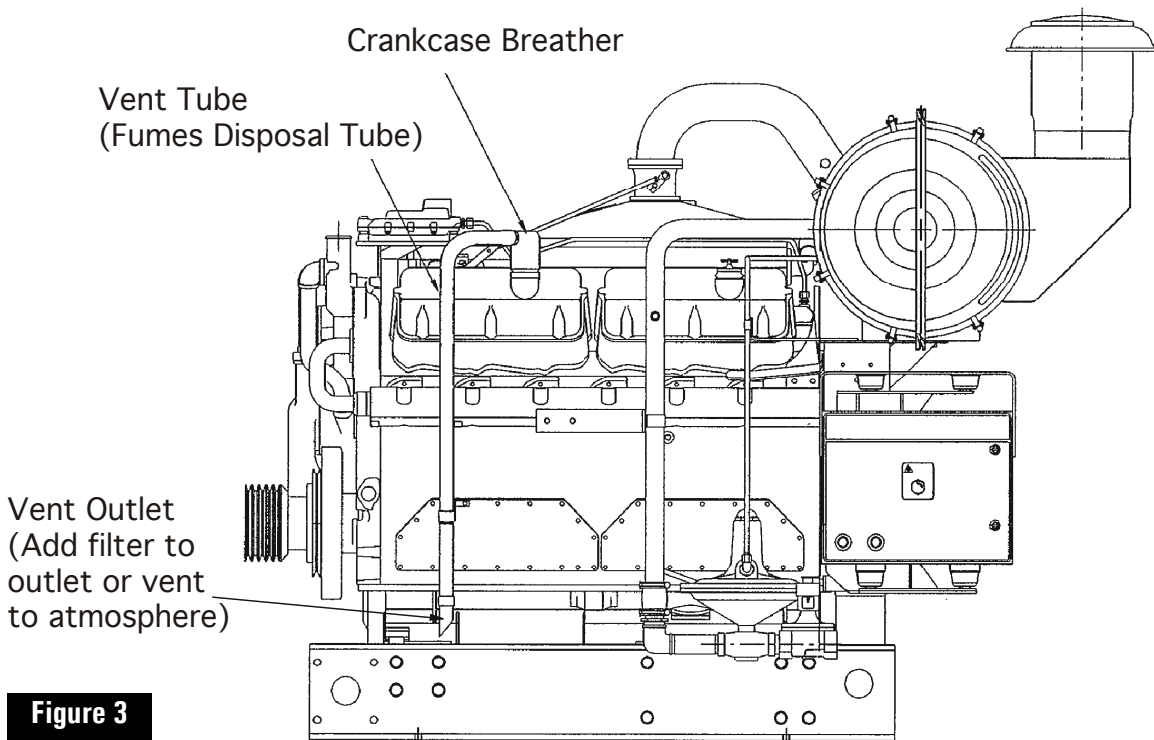

**Figure 3**

Although a non-ingestive system is less complex than an ingestive system, there are a number of requirements and considerations for the effective venting of crankcase emissions.

Do not vent emissions directly into the engine room without filtration.

- Emissions can clog air filters, consequently causing engine damage.
- Exposure to crankcase emissions can cause problems in electrical equipment.

- Emissions can be a health hazard if discharged in a poorly ventilated room.
- Use a crankcase ventilation system to properly filter and vent emissions to the atmosphere.
- Multiple engines at a site require a separate vent lines for each engine. This prevents fumes and moisture produced by a running engine from entering an idle engine. The addition of moisture into an engine can cause corrosion and buildup of harmful deposits.
- Use appropriately sized vent pipes.

Crankcase vent pipes must be large enough to minimize back pressure. Through the entire life of the engine, blow-by may vary dramatically depending on engine operating temperature and type of oil used. As a general rule, blow-by on a new engine is approximately 0.02 m<sup>3</sup>/hr bkW (0.5 ft<sup>3</sup>/hr bhp). Adequately size the vent pipes to accommodate a worn engine, with a blow-by rate of 0.04 m<sup>3</sup>/hr bkW (1 ft<sup>3</sup>/hr bhp). Size the vent pipe with a maximum of 13 mm H<sub>2</sub>O (0.5 in. H<sub>2</sub>O) pressure drop at full load.

The following formulas allow the crankcase ventilation designer to calculate a pipe diameter that will provide a back pressure of less than 13 mm H<sub>2</sub>O (0.5 in. H<sub>2</sub>O).

Use the following formulas to calculate back pressure:

$$P \text{ (kPa)} = \frac{L \times S \times Q^2 \times 3.6 \times 10^6}{D^5}$$

$$P \text{ (in. H}_2\text{O)} = \frac{L \times S \times Q^2}{187 \times D^5}$$

Where:

P = Back pressure (kPa), (in. H<sub>2</sub>O)

psi = 0.0361 x in. water column

kPa = 0.00981 x mm water column

L = Total Equivalent Length of pipe (m), (ft)

Q = Exhaust gas flow (m<sup>3</sup>/min), (cfm)

D = Inside diameter of pipe (mm), (in.)

S = Density of gas (kg/m<sup>3</sup>), (lb/ft<sup>3</sup>)

S (kg/m<sup>3</sup>) = 1.08

S (lb/ft<sup>3</sup>) = 0.067

To obtain equivalent length of straight pipe for various elbows:

$$\text{Standard Elbow (radius = diameter)} \quad L = \frac{33D}{X}$$

$$\text{Long Radius Elbow (radius = 1.5 diameter)} \quad L = \frac{20D}{X}$$

$$\text{45° Elbow (radius = 1.5 diameter)} \quad L = \frac{15D}{X}$$

$$\text{Square Elbow (radius = 1.5 diameter)} \quad L = \frac{66D}{X}$$

Where:

$$X = 1000 \text{ mm (12 in)}$$

Calculate the pipe diameter according to the formula, and then choose the next larger commercially available pipe size.

As evidenced in the formulas, if 90° bends are required, then using long radius elbows, with a radius of 1.5 times the pipe diameter, helps lower resistance.

Loops or low spots in a crankcase vent pipe must be avoided to prevent condensation from building up in the pipe and restricting the emissions discharge. Where horizontal runs are required, install the pipe with a gradual slope from the engine as shown in **Figure 4**. The slope should be approximately 41.7 mm/m (1/2 in/ft).

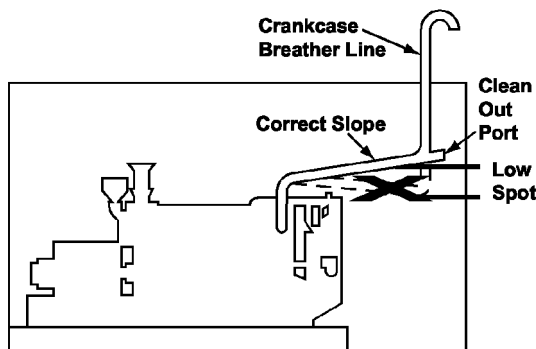

The weight of the vent pipes will require separate off-engine supports as part of the installation design. Any horizontal or vertical run of pipe that cannot be disassembled for cleaning should have clean-out ports installed.

Crankcase emissions from non-ingressive crankcase ventilation systems must not discharge into the air ventilation ducts or exhaust pipes. Ducts and pipes on these engines will become coated with oily deposits that create a fire hazard. Crankcase emissions discharge piping should not be connected to other discharge piping coming from systems where higher pressures are possible. Back flows into the crankcase are possible that may cause damage to the engine.

Vent the crankcase pipe directly into the atmosphere and direct it to keep rain or spray from entering the engine. Give consideration to equipment located near the discharge area as well as to the building itself. Over a period of time, very small amounts of oil carry-over can accumulate and become unsightly, even harmful, to auxiliary equipment.

**Figure 4**

Packaged units with engine driven blowers should consider alternative crankcase pipe routing as shown in **Figure 5**. This will prevent the crankcase emissions from being drawn into the blower and radiator.

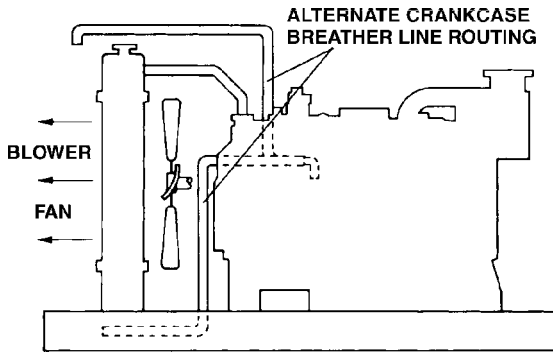
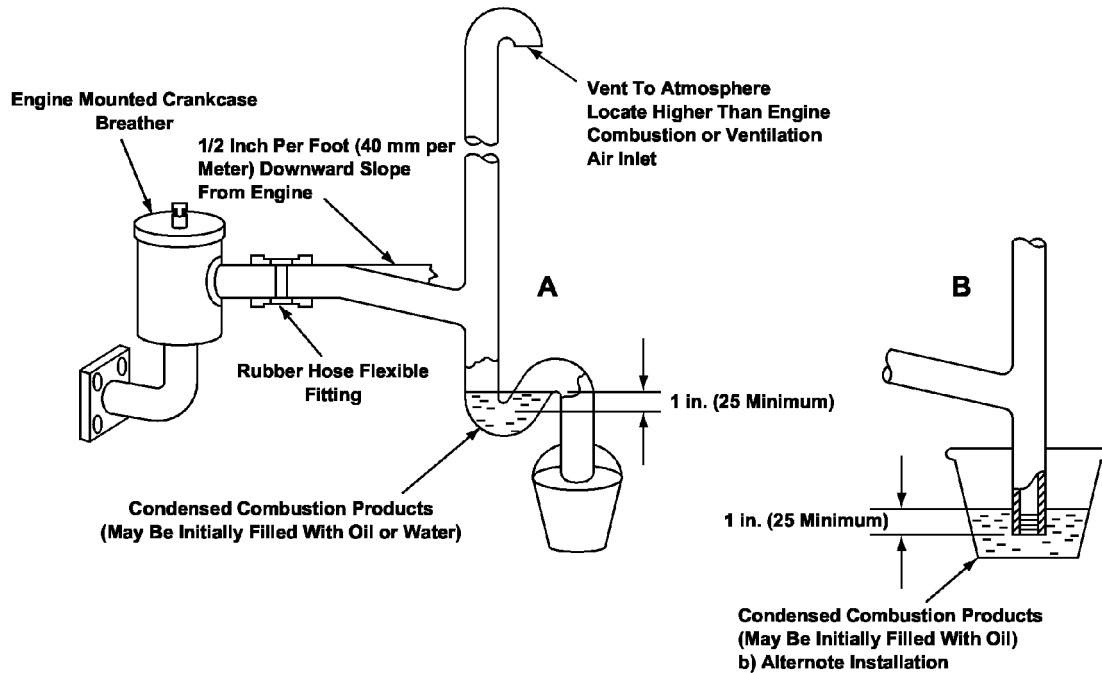

**Figure 5**

A drip collector installed near the engine will minimize the amount of oil discharge through the vent pipe. This arrangement also requires a trap that will prevent crankcase gases from venting into the engine room. Refer to **Figure 6**.

If a trap, as shown in **Figure 6** part B is used, the designer must be sure the drip collector can be removed or drained for disposal. Another alternative is to install a valve on the end of the drip pipe and periodically drain it.

### Crankcase Ventilation Traps

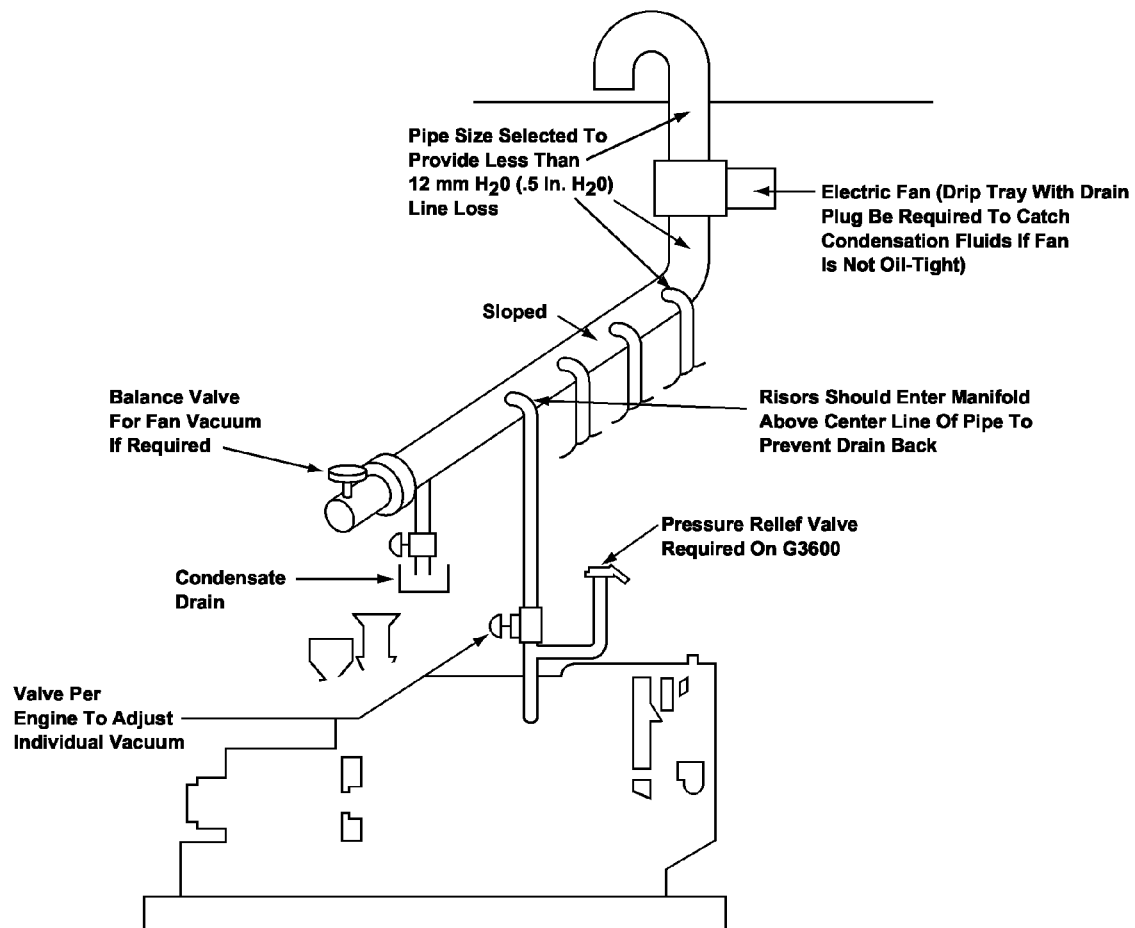

**Figure 6**

**Figure 7** illustrates a powered blow-by disposal system for a multiple engine installation. There are two main advantages to a powered system. The emissions will become diluted with air for better dispersal into the atmosphere, and it can improve oil life by removing the nitric oxides from the crankcase before they can cause nitration of the oil.

Since a vacuum will be drawn with a powered system, an air filter on the engine crankcase is required. This will filter the air entering the crankcase and prevent dirt from being introduced into the oil. A valve connected in the line to each engine controls the flow of crankcase fumes out of the engine.

**Powered Blow-by Disposal System**



**Figure 7**



---

## Diluting Crankcase Emissions

The following is a step-by-step procedure to dilute crankcase emissions with fresh air and is needed when designing a crankcase ventilation system.

Measuring blow-by for each installation is recommended for best performance.

To set up the system, a Blow-by/Air Flow Indicator is required.

1. Measure the amount of combustion blow-by for a given engine. This is done by closing the crankcase ventilation valve, blocking the crankcase air filter, and attaching the blow-by indicator to the oil fill spout. The reading on the indicator is the engine's blow-by. All measurements are to be taken with the engine running at rated speed, load, and temperature.
2. Unplug the crankcase air filter and connect the blow-by indicator to it. Slowly open the crankcase ventilation valve until the indicator reads the same as in step 1. This procedure will allow an equal amount of air to be

drawn into the crankcase as is being blown past the piston rings. This will sufficiently dilute the fumes and increase oil life.

3. Perform this procedure for each engine.
4. Make a final check of the crankcase pressure to insure the vacuum on the engine is less than 25.4 mm H<sub>2</sub>O (1 in. H<sub>2</sub>O).

### **Balance Valve**

Sometimes it is difficult to precisely size the blower for a powered system. If the only blower available is too large, it may draw too much vacuum on the crankcase ventilation valves and make adjustments difficult. To overcome this problem, a balance valve can be connected on the vacuum side of the blower to allow air to be drawn in the system and reduce the vacuum pressure on the adjusting valves.

An optional relief valve may be used to limit crankcase pressure to 0.14 kPa (0.5 in. H<sub>2</sub>O). This is used to avoid problems if the crankcase ventilation blower is not engaged.

## **Reference Material**

The following information is provided as additional reference to subjects discussed in this manual.

### **REHS0883**

Special Instruction

Installation and Maintenance of the Fumes Disposal Filter G3516B

[www.cat.com/power-systems](http://www.cat.com/power-systems)

**BUILT FOR IT.**

LEBW4958-04

Information contained in this publication may be considered confidential. Discretion is recommended when distributing. Materials and specifications are subject to change without notice.

©2015 Caterpillar. All rights reserved. CAT, CATERPILLAR, BUILT FOR IT, their respective logos, "Caterpillar Yellow", the "Power Edge" trade dress as well as corporate ad product identity used herein, are trademarks of Caterpillar and may not be used without permission.

