

966L/972L

Wheel Loaders

2017



	966L		972L	
Engine Model	Cat® C9.3 ACERT™		Cat C9.3 ACERT	
Maximum Power – ISO 14396	227 kW	309 hp (metric)	242 kW	329 hp (metric)
Maximum Net Power – ISO 9249	207 kW	281 hp (metric)	222 kW	302 hp (metric)
Bucket Capacities	3.20-7.40 m ³		3.40-9.90 m ³	
Operating Weight	23 220 kg*		24 897 kg**	

*For 4.2 m³ general purpose bucket with BOCE.

**For 4.8 m³ general purpose bucket with BOCE.

The 966L and 972L Wheel Loaders apply proven technologies systematically and strategically to meet your high expectations for reliability, productivity, fuel efficiency, and long service life.

Contents

Reliable	4
Durable	5
Productive	6
Fuel Efficient	7
Easy to Operate	8
Serviceable	9
Integrated Technologies	10
Versatile	12
Owning Costs	13
Operating Costs	14
Specifications	15
Standard Equipment	29
Optional Equipment	30
Notes	31





Reliability

- Cat C9.3 ACERT engine offers a combination of proven electronic, fuel and air systems and meets China Nonroad Stage III emission standards equivalent to U.S. EPA Tier 3/EU Stage IIIA, or emissions equivalent to Tier 2/Stage II emissions standards.
- Utilizing rigorous component design and machine validation processes results in unmatched reliability, durability and high uptime.

Durability

- Heavy-duty powershift transmission and axles handle extreme applications.
- Improved hydraulic hose routing reduces potential hose wear.
- Full flow hydraulic filtration system with additional loop filtration improves hydraulic system robustness and component life.

Productivity

- Increased engine power improves machine performance and response.
- Lock-up clutch torque converter, combined with lock-to-lock shifting, delivers smooth shifts, fast acceleration and speed on grade.
- High capacity torque converter results in greater digging efficiency.
- Easy-to-load Performance Series Buckets feature a wider mouth and curved side plates that improve material retention (fill factor) and decrease cycle times.

Fuel Efficiency

- Up to 15% lower fuel consumption than H Series.*
 - Power dense ACERT engine burns less fuel by providing power and torque when needed.
- *Actual results may vary based on factors such as, but not limited to, machine configuration, operator technique, machine application, climate, etc.

Ease of Operation

- Best-in-class operator environment provides unmatched comfort, visibility, and efficiency.
- Intuitive, ergonomic controls keep operators focused on their work.

Safety

- Excellent cab access with wide door and stair-like steps.
- Floor to ceiling windshield, large mirrors with integrated spot mirrors and rear vision camera provide industry leading all-around visibility.

Serviceability

- One-piece tilting hood with side and rear doors; hydraulic and electrical service centers make access fast and easy.
- Convenient access to fuel fill, oil fill, filters and daily maintenance points means less servicing time required.

Reliable

Proven components and technology you can count on.



Caterpillar Designed Components

- Utilizing rigorous design and machine validation processes have delivered unmatched reliability, durability and high uptime for generations.
- Components used to build Cat wheel loaders are designed and manufactured to Caterpillar quality standards to ensure maximum performance even in extreme operating conditions.
- Heavy duty components reduce the risk of premature wear resulting in increased uptime and reduce operating costs over the lifetime of the machine.

Equipment Monitoring

- Monitoring product health is key to maintaining reliability of any equipment.
- Cat Connect technologies (Product Link™, VisionLink®) take the guesswork out of equipment management.
- Many programs offered by your Cat dealer make tracking your machine health quick and easy.

Renowned Cat Dealer Support

- Cat dealers provide the best support when it comes to servicing your machine, increasing your uptime on the job site.
- Preventive maintenance programs like Scheduled Oil Sampling (S-O-SSM) analysis or comprehensive Customer Support Agreements help reduce lifetime maintenance costs.
- Best-in-class parts availability maximizes uptime.



Durable

Better designed to meet your needs.

Power Train

- Cat C9.3 engine with ACERT technology maintains engine performance, efficiency and durability.
- Rugged, planetary powershift transmission and axles handle extreme applications effectively resulting in reliable performance and durable life.
- Front axle is rigidly mounted to the frame in order to withstand internal torque loads and still maintain support for the wheel loader.
- Rear axle can oscillate to ± 13 degrees helping to ensure all four wheels stay on the ground providing stability even in the roughest terrain, for excellent stability and traction.

Hydraulic System

- Improved hydraulic hose routing reduces potential hose wear.
- Full flow hydraulic filtration system with additional loop filtration improves hydraulic system robustness and component life.

Linkage, Buckets and Frames

- Proven Z-bar linkage with Performance Series Buckets offers excellent penetration into the pile, high breakout forces, good roll back angles and faster dig times resulting in improved tire life, superior fuel efficiency and exceptional production capabilities.
- Robotically welded two-piece structural frame design provides strong and rigid structures that absorb all the forces associated to penetration, loading and twisting.
- The L Series articulating hitch system joins the front and rear frames providing increased bearing force capacity.



Productive

Work smart and move more.



Engine

- Increased engine power in the 966L by approximately 10% and 5% in the 972L (compared to H series) improves machine performance and response.

Transmission

- Heavy-duty powershift transmission includes a lock up clutch torque converter, standard, that matches engine power and hydraulics to maximize machine performance and fuel efficiency.

Performance Series Buckets

- Easy-to-load Performance Series Buckets feature wider mouth, longer floor and curved side plates that improve material retention (fill factor) and decrease cycle times.

Dealer Support

- Your Cat dealer can help with operator training to help boost your productivity and profits.

Fine-tuned Technologies for the Right Applications

- Lock-up clutch torque converter, combined with lock-to-lock shifting, delivers smooth shifts, fast acceleration and speed on grade.
- High capacity torque converter results in greater digging efficiency.
- Z-bar linkage provides high breakout force at ground level in bucket applications.
- Optional aggregate packages are available for specific loose aggregate rehandling applications, such as truck loading, hopper charging, stockpiling, and load and carry.*
- Optional high lift linkage offers increased hinge pin height to load more easily.
- Optional fully automatic traction control system (differential locks) improves performance in the pile and poor underfoot conditions while reducing tire wear with no operator intervention required.

*Please consult your Cat dealer to ensure proper machine configuration selection in conformance to Caterpillar payload policy.



Fuel Efficient

Engineered to lower your operating costs.

Engine and Emissions

- Cat C9.3 ACERT engine is designed for maximum fuel efficiency and increased power density. Based on local requirements, it meets China Nonroad Stage III emission standards equivalent to U.S. EPA Tier 3/EU Stage IIIA, or emissions equivalent to Tier 2/Stage II emissions standards.
- Engine features innovative Cat electronics, fuel injection process, and air-management systems, reducing fuel consumption.

Efficient Systems and Components

- Innovative systems intelligently lower average working engine speeds and reduce overall system heat loads resulting in significantly improved performance and fuel efficiency.

Advanced Systems with Innovative Integration

- Deep system integration of engine power train, hydraulic system and cooling system result in lower fuel consumption on average compared to H Series.

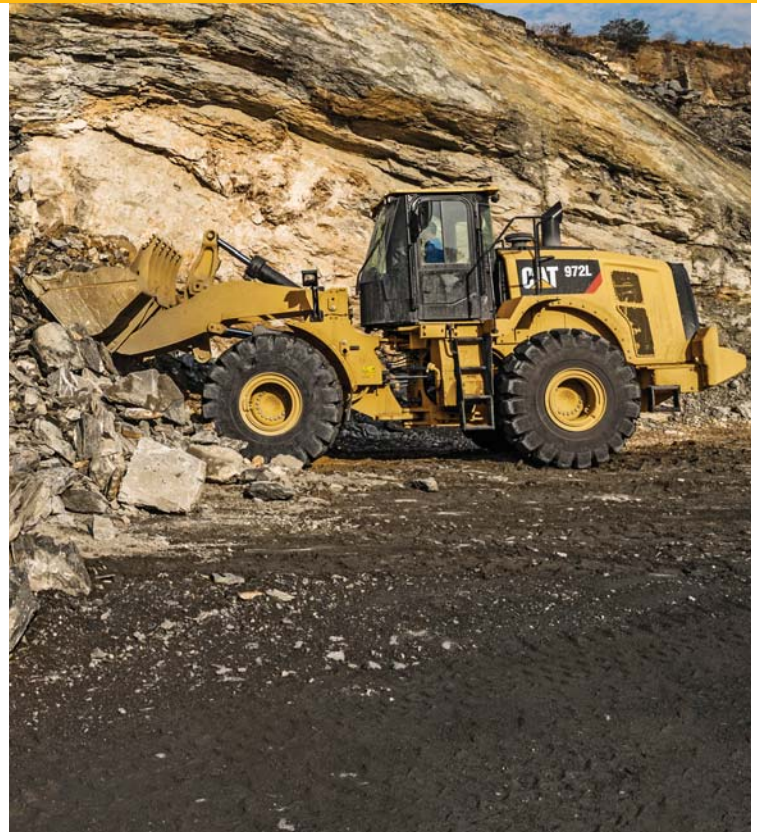

- Up to 15% lower fuel consumption than H Series.*
- Power dense ACERT engine burns less fuel by providing power and torque when needed.
- Performance Series Buckets feature a longer floor that easily digs through the pile resulting in lower fuel consumption.
- Productive Economy Mode provides maximum fuel savings with minimal productivity impact.
- Load sensing hydraulics result in proportional flow for implement and steering on demand.
- On-Demand Fan improves fuel efficiency, lower noise levels and reduced radiator plugging.
- Engine Idle Management System (EIMS) maximizes fuel efficiency by reducing engine rpm.
- Engine Idle Shutdown saves fuel and reduces hour accumulation on your machine.

*Actual results may vary based on factors such as, but not limited to, machine configuration, operator technique, machine application, climate, etc.

Easy to Operate

Safe. Comfortable. Efficient.



Operator Environment

- Best-in-class operator environment features four post Roll Over Protection System (ROPS) cab providing unmatched comfort, visibility, and efficiency.
- Seat-mounted implement controls provide operators with precise control of the work tool, all while moving with the seat for maximum comfort.
- Low-effort steering wheel offers precise control in demanding operations.
- Streamlined control panel includes easy to reach highly utilized machine controls increasing operator efficiency.
- Viscous cab mounts connect cab to frame of machine, decreasing noise and vibration resulting in a sustainable work environment and well-rested efficient, productive operator.
- Optional ride control system with dual accumulators provides excellent ride quality and lowers cab vibrations.



Safety

- Excellent cab access with wide door and stair-like steps.
- Floor to ceiling windshield, large mirrors with integrated spot mirrors and rear vision camera provide industry leading all-around visibility.
- Robust, repositioned grab bars provide safe access to machine platforms.
- Integrated rear vision camera enhances visibility behind machine helping operators work safely and productively.





Serviceable

Easy to maintain. Easy to service.



Engine Access

- One-piece tilting hood with side and rear doors makes access fast and easy.
- Best-in-class service access to engine, oil levels and coolant sight gauge means less servicing time required.

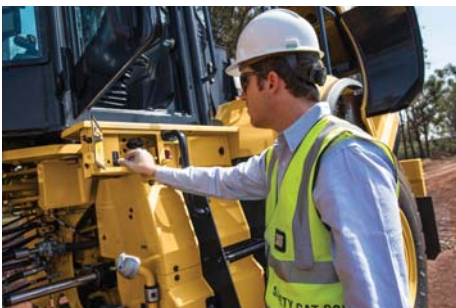

Service Centers

- Electrical and hydraulic service centers provide grouped convenient access enhancing safety and convenience while reducing service time.
- Safe, convenient access to fuel fill and daily maintenance points means less servicing time required.



Parking Brake

- External caliper disc parking brakes are easily accessible for inspection and service.

Cooling System

- Cooling system is readily accessible for clean out and maintenance.
- Hydraulic and A/C cooler cores swing out providing easy access to both sides for cleaning.
- Access panel on left side of cooling package swings down to provide access to back side of engine coolant and Air-to-Air After Cooler (ATAAC).
- Optional variable pitch fan can automatically purge cooler cores by periodically reversing airflow when needed.



Integrated Technologies

Monitor, Manage, and Enhance Job Site Operations.

Cat Connect makes smart use of technology and services to improve your job site efficiency. Using the data from technology-equipped machines, you'll get more information and insight into your equipment and operations than ever before.

Cat Connect services are also available from your dealership including:



EQUIPMENT
MANAGEMENT

Equipment Management – increase uptime and reduce operating costs.



PRODUCTIVITY

Productivity – monitor production and manage job site efficiency.



SAFETY

Safety – enhance job site awareness to keep your people and equipment safe.

Consult your local dealer on the services available.

Featured Cat Connect technologies include:



LINK Technologies

LINK technologies wirelessly connect you to your equipment giving you access to essential information you need to know to run your business. Link data can give you valuable insight into how your machine or fleet is performing so you can make timely, fact-based decisions that can boost job site efficiency and productivity.

Product Link/VisionLink

- Product Link is deeply integrated into your machine to take the guesswork out of equipment management.
- Easy access to timely information like machine location, hours, fuel usage, idle time and event codes via the online VisionLink user interface can help you effectively manage your fleet and lower operating cost.

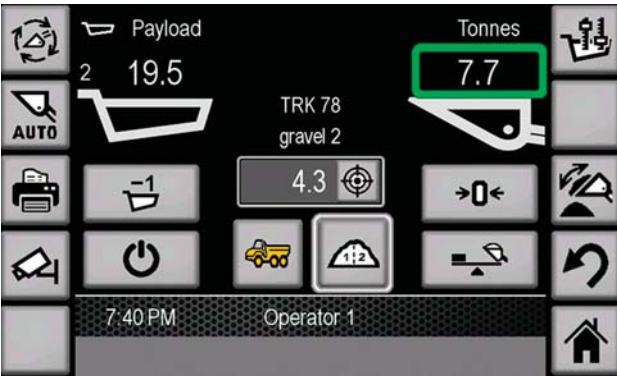

PAYLOAD Technologies

PAYLOAD technologies provide accurate weighing of materials being loaded and hauled. Payload data is displayed for loader operators in real-time to improve productivity, reduce overloading, and recorded to track material movement by shift.

Cat Production Measurement 2.0 (Optional)

- Brings payload weighing to the cab, enabling you to weigh loads “on-the-go” during loading operations.
- Integrated Cat multi-function touchscreen display with graphical user interface is easy to understand and adds no clutter to the cab.
- Easy calibration procedure requires no special tools and reduces operational complexity.
- Low Lift Weigh and Tip-off features enable faster loading of trucks to their maximum capacity.
- VisionLink common back-office interface provides you a quick summary of loader operations, including payload productivity and efficiency.
- Optional Advanced Productivity subscription provides comprehensive actionable information to help you manage and improve the productivity and profitability of your operations.



DETECT Technologies

DETECT technologies enhance operator awareness of the environment around working equipment and provide alerts to help keep people and assets safe.

Rear Vision Camera

- Integrated into standard display, enhances visibility behind the machine helping you work confidently.
- Optional second display can be added to provide a dedicated rear view of the job site.

Rear Object Detection (Optional)

- Integrated into touchscreen display, the radar system warns you of an object in critical zone while going in reverse.
- Increased awareness of the working environment enhances site safety.

Versatile

Do more jobs with one machine.



Fusion™ Quick Coupler

Improved Machine Performance

- Fusion Coupler System (patented) provides performance virtually identical to pin on – with all the flexibility of a quick coupler system.
- The Fusion Coupler sits back, close into the loader arms – minimizing offset and increasing the machine's performance.

No Loss of Performance

- Fusion is designed to integrate the work tool and the machine by pulling the coupler and tool closer into the loader which translates to increased lifting ability when compared to machines equipped with other coupler systems.

Unsurpassed Durability

- Advanced wedging mechanism creates tight, rattle-free fit which eliminates play and wear – resulting in long service life.

Performance Series Buckets

Load Easy, Fuel Efficient, Carry More

- Buckets utilize a system based approach to balance bucket shape with machine's linkage, weight, lift and tilt capacities.
- Reduced dig times and better material retention results in significant productivity and fuel efficiency improvements.

Lower Operating Costs

- Buckets feature longer floor that easily digs through pile and provides excellent visibility for operators to see when bucket is full.
- Less time digging in the pile results in lower fuel consumption and improved tire life.
- Unique spill guard protects cab and linkage components from material overflow.

Higher Productivity

- Buckets achieve higher fill factors – ranging from 100% to 115% depending on the machine application and material type.
- Buckets feature curved side profile to maximize material retention.

Options to Fit the Job

- Performance Series buckets are available in General Purpose and Material Handling styles.





Owning Costs

Proven best investment.

Cat Product Link

- Cat Product Link allows remote monitoring of equipment to improve overall fleet management effectiveness.
- Product Link is deeply integrated into machine systems; information such as events, diagnostic codes, hours, fuel, idle time and other detailed information are transmitted to a secure web based application, VisionLink.
- VisionLink includes powerful tools to convey information to users and dealers, including mapping, working and idle time, fuel level and more.

S-O-S Services

- Helps manage component life and decrease machine downtime, increasing productivity and efficiency.
- Regular fluid sampling can help track what is going on inside your machine. Wear related problems are predictable and easily repairable.
- Maintenance can be done to accommodate your schedule, resulting in increased uptime and flexibility in maintenance repairs before failure.

Cat Autolube System

The optional, fully integrated Cat Autolube system provides full system monitoring and diagnostic test visibility by being integrated into the machine, display and VisionLink. Easy access to the refill pump and grease zerks means simple, fast servicing.

Parts Availability

- Caterpillar provides an unsurpassed level of personalized service to help you work more cost effectively and efficiently.
- By utilizing a worldwide parts network Cat dealers help minimize machine downtime and save money by fast delivery of replacement parts.

Resale Value

- Caterpillar is not only known for machines that are better built, but provides product and dealer support to maintain the reliability and durability of your machine.

Operating Costs

Save time and money by working smart.



Most Fuel Efficient Machines in Industry

- Data from customer machines show Cat wheel loaders are the most fuel efficient machines in the industry.

Engine, Hydraulics and Transmission

- Deep system integration results in more productivity, lower fuel consumption, without interrupting machine performance – making it seamless to you and your operators.

Lock-up-Clutch Torque Converter and Shift Strategy

- Reduced torque interruption increases driveline efficiency, conserving fuel; auto transmission mode keeps engine rpm low, reducing fuel consumption while delivering optimal machine performance.

Performance Series Buckets

- Performance Series buckets deliver faster fill times and better material retention, ultimately reducing cycle times while improving productivity and fuel efficiency.

Optional Automatic Traction Control (Differential Locks)

- Automatic traction control, with no operator intervention required, increases traction and reduces tire scuffing compared to other traction aids, further reducing your operating costs.

External Caliper Disc Parking Brakes

- External caliper disc parking brake does not have the inefficiencies of enclosed wet parking brakes due to brake discs running in oil nor is there any oil to change reducing fuel and maintenance costs.

966L/972L Wheel Loaders Specifications

Engine – 966L

Engine Model	Cat C9.3 ACERT	
Maximum Power (1,700 rpm)		
ISO 14396	227 kW	309 hp (metric)
Maximum Net Power (1,700 rpm)		
ISO 9249	207 kW	281 hp (metric)
Peak Torque (1,200 rpm)		
ISO 14396	1581 N·m	
Maximum Net Torque (1,000 rpm)		
ISO 9249	1507 N·m	
Bore	115 mm	
Stroke	149 mm	
Displacement	9.3 L	

- Cat engine with ACERT Technology – based on local requirements, meets China Nonroad Stage III emission standards equivalent to Tier 3/Stage IIIA, or emissions equivalent to Tier 2/Stage II emissions standards.
- The power ratings apply at the stated speed when tested under the reference conditions for the specified standards.
- The net power advertised is the power available at the flywheel when the engine is equipped with fan, alternator, air cleaner and aftertreatment.
- The gross power advertised is with the fan at maximum speed.

Buckets – 966L

Bucket Capacities	3.20-7.40 m ³
-------------------	--------------------------

Weight – 966L

Operating Weight	23 220 kg
------------------	-----------

- Weight based on a machine configuration with Michelin 26.5R25 XHA2 L3 radial tires, full fluids, operator, standard counterweight, cold start, roading fenders, Product Link, open/open axles (front/rear), power train guard, secondary steering, sound suppression and a 4.2 m³ general purpose bucket with BOCE.

Operating Specifications – 966L

Static Tipping Load – Full 37° Turn	
With Tire Deflection	14 668 kg
No Tire Deflection	15 822 kg
Breakout Force	173 kN

- For a machine configuration as defined under “Weight.”
- Full compliance to ISO 14397-1:2007 Sections 1 thru 6, which requires 2% verification between calculations and testing.

Engine – 972L

Engine Model	Cat C9.3 ACERT	
Maximum Power (1,800 rpm)		
ISO 14396	242 kW	329 hp (metric)
Maximum Net Power (1,800 rpm)		
ISO 9249	222 kW	302 hp (metric)
Peak Torque (1,200 rpm)		
ISO 14396	1710 N·m	
Maximum Net Torque (1,100 rpm)		
ISO 9249	1632 N·m	
Bore	115 mm	
Stroke	149 mm	
Displacement	9.3 L	

- Cat engine with ACERT Technology – based on local requirements, meets China Nonroad Stage III emission standards equivalent to Tier 3/Stage IIIA, or emissions equivalent to Tier 2/Stage II emissions standards.
- The power ratings apply at the stated speed when tested under the reference conditions for the specified standards.
- The net power advertised is the power available at the flywheel when the engine is equipped with fan, alternator, air cleaner and aftertreatment.
- The gross power advertised is with the fan at maximum speed.

Buckets – 972L

Bucket Capacities	3.4-9.90 m ³
-------------------	-------------------------

Weight – 972L

Operating Weight	24 897 kg
------------------	-----------

- Weight based on a machine configuration with Michelin 26.5R25 XHA2 L3 radial tires, full fluids, operator, standard counterweight, cold start, roading fenders, Product Link, open/open axles (front/rear), power train guard, secondary steering, sound suppression and a 4.8 m³ general purpose bucket with BOCE.

Operating Specifications – 972L

Static Tipping Load – Full 37° Turn	
With Tire Deflection	16 164 kg
No Tire Deflection	17 421 kg
Breakout Force	196 kN

- For a machine configuration as defined under “Weight.”
- Full compliance to ISO 14397-1:2007 Sections 1 thru 6, which requires 2% verification between calculations and testing.

966L/972L Wheel Loaders Specifications

Transmission

Forward 1	6.5 km/h
Forward 2	13.1 km/h
Forward 3	23.5 km/h
Forward 4	39.5 km/h
Reverse 1	7.1 km/h
Reverse 2	14.4 km/h
Reverse 3	25.9 km/h
Reverse 4	39.5 km/h

- Maximum travel speed in standard vehicle with empty bucket and standard L3 tires with 826 mm roll radius.

Hydraulic System

Implement Pump Type	Variable Displacement Piston
Implement System	
Maximum Pump Output (2,300 rpm*)	360 L/min
Maximum Operating Pressure	31,000 kPa
Optional 3rd Maximum Flow	240 L/min
Optional 3rd Maximum Pressure	20,680 kPa

Hydraulic Cycle Time with Rated Payload:

Raise from Carry Position	6.1 Seconds
Dump, at Maximum Raise	1.4 Seconds
Lower, Empty, Float Down	2.6 Seconds
Total	10.1 Seconds

*Engine speed.

Brakes

Brakes	Brakes meet ISO 3450:2011 standards
--------	-------------------------------------

Axles

Front	Fixed
Rear	Oscillating ± 13 degrees
Maximum Single-Wheel Rise and Fall	502 mm

Cab

ROPS/FOPS	ROPS/FOPS meet ISO 3471:2008 and ISO 3449:2005 Level II standards
-----------	---

Sound

The sound values indicated below are for specific operating conditions only. Machine and operator sound levels will vary at different engine and/or cooling fan speeds. Hearing protection may be needed when the machine is operated with a cabin that is not properly maintained, or when the doors and/or windows are open for extended periods or in a noisy environment.

With Cooling Fan Speed at Maximum Value:

Operator Sound Pressure Level (ISO 6396:2008)	72 dB(A)
Exterior Sound Power Level (ISO 6395:2008)	109 dB(A)
Exterior Sound Pressure Level (SAE J88:2013)	76 dB(A)*

With Cooling Fan Speed at 70% of Maximum Value:**

Operator Sound Pressure Level (ISO 6396:2008)	69 dB(A)
Exterior Sound Power Level (ISO 6395:2008)	108 L _{WA} ***

*Distance of 15 m, moving forward in second gear ratio.

**For machines in countries that adopt the "EU Directives."

***European Union Directives "2000/14/EC" as amended by "2005/88/EC."

Service Refill Capacities

Fuel Tank	303 L
Cooling System	71.6 L
Crankcase	24.5 L
Transmission	58.5 L
Differentials and Final Drives – Front	57 L
Differentials and Final Drives – Rear	57 L
Hydraulic Tank	125 L

966L/972L Wheel Loaders Specifications

966L Dimensions

All dimensions are approximate.

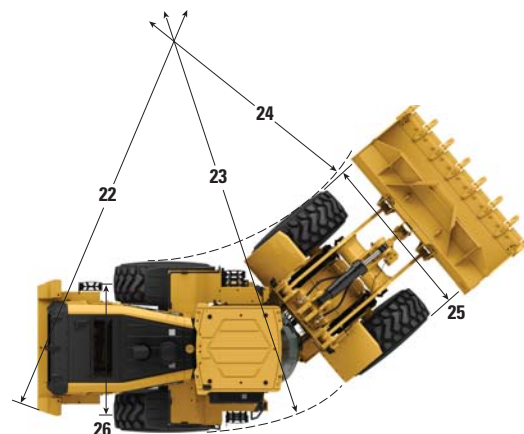
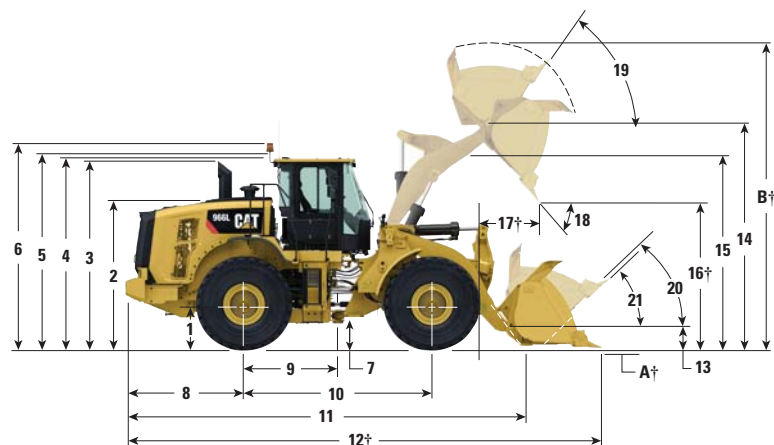

	Standard Lift	High Lift
1 Height to Axle Centerline	799 mm	799 mm
2 Height to Top of Hood	2818 mm	2818 mm
3 Height to Top of Exhaust Pipe	3522 mm	3522 mm
4 Height to Top of ROPS	3587 mm	3587 mm
5 Height to Top of Product Link Antenna	3636 mm	3636 mm
6 Height to Top of Warning Beacon	3859 mm	3859 mm
7 Ground Clearance	434 mm	434 mm
8 Center Line of Rear Axle to Edge of Counterweight	2251 mm	2500 mm
9 Center Line of Rear Axle to Hitch	1775 mm	1775 mm
10 Wheelbase	3550 mm	3550 mm
11 Overall Length (without bucket)	7362 mm	8111 mm
12 Shipping Length (with bucket level on ground)*†	8750 mm	9570 mm
13 Hinge Pin Height at Carry Height	630 mm	778 mm
14 Hinge Pin Height at Maximum Lift	4235 mm	4793 mm
15 Lift Arm Clearance at Maximum Lift	3643 mm	4140 mm
16 Dump Clearance at Maximum Lift and 45° Discharge*†	2991 mm	3549 mm
17 Reach at Maximum Lift and 45° Discharge*†	1353 mm	1328 mm
18 Dump Angle at Maximum Lift and Dump (on stops)*	49 degrees	48 degrees
19 Rack Back at Maximum Lift*	62 degrees	71 degrees
20 Rack Back at Carry Height*	50 degrees	49 degrees
21 Rack Back at Ground*	42 degrees	39 degrees
22 Turning Radius to Counterweight	6804 mm	6804 mm
23 Turning Radius to Outside of Tires	6761 mm	6761 mm
24 Turning Radius to Inside of Tires	3853 mm	3853 mm
25 Width Over Tires – Maximum (unloaded)	2991 mm	2991 mm
Width Over Tires – Maximum (loaded)	3009 mm	3009 mm
26 Tread Width	2230 mm	2230 mm

*With 4.2 m³ general purpose pin on bucket with BOCE (see Operating Specifications for other buckets).

†Dimensions are listed in Operating Specifications charts.

All height and tire related dimensions are with Michelin 26.5R25 XHA2 L3 tires (see Tire Option Chart for other tires.) "Width Over Tires" dimensions are over the bulge and include growth.

All height and tire related dimensions are with Michelin 23.5R25 XHA2 L3 radial tires (see Tire Option Chart for other tires.) "Width Over Tires" dimensions are over the bulge and include growth.

966L/972L Wheel Loaders Specifications

972L Dimensions

All dimensions are approximate.

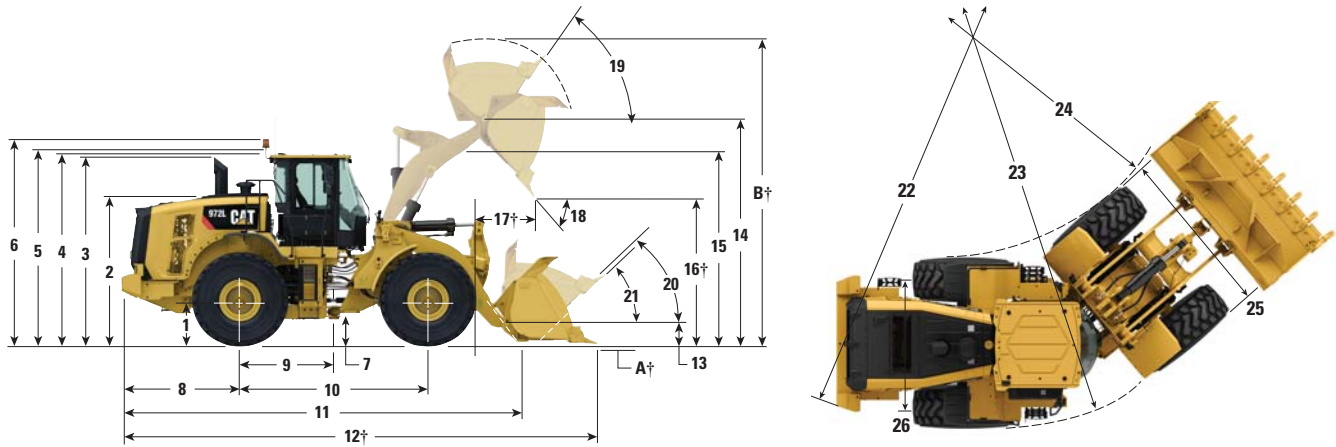

	Standard Lift	High Lift	Extended Capacity
1 Height to Axle Centerline	799 mm	799 mm	799 mm
2 Height to Top of Hood	2818 mm	2818 mm	2818 mm
3 Height to Top of Exhaust Pipe	3522 mm	3522 mm	3522 mm
4 Height to Top of ROPS	3587 mm	3587 mm	3587 mm
5 Height to Top of Product Link Antenna	3636 mm	3636 mm	3636 mm
6 Height to Top of Warning Beacon	3859 mm	3859 mm	3859 mm
7 Ground Clearance	434 mm	434 mm	434 mm
8 Center Line of Rear Axle to Edge of Counterweight	2500 mm	2500 mm	2500 mm
9 Center Line of Rear Axle to Hitch	1775 mm	1775 mm	1775 mm
10 Wheelbase	3550 mm	3550 mm	3550 mm
11 Overall Length (without bucket)	7773 mm	8111 mm	7610 mm
12 Shipping Length (with bucket level on ground)*†	9315 mm	9650 mm	9164 mm
13 Hinge Pin Height at Carry Height	680 mm	778 mm	631 mm
14 Hinge Pin Height at Maximum Lift	4458 mm	4793 mm	4235 mm
15 Lift Arm Clearance at Maximum Lift	3843 mm	4140 mm	3643 mm
16 Dump Clearance at Maximum Lift and 45° Discharge*†	3154 mm	3490 mm	2920 mm
17 Reach at Maximum Lift and 45° Discharge*†	1357 mm	1380 mm	1413 mm
18 Dump Angle at Maximum Lift and Dump (on stops)*	48 degrees	48 degrees	48 degrees
19 Rack Back at Maximum Lift*	56 degrees	71 degrees	62 degrees
20 Rack Back at Carry Height*	50 degrees	49 degrees	50 degrees
21 Rack Back at Ground*	41 degrees	39 degrees	42 degrees
22 Turning Radius to Counterweight	6804 mm	6804 mm	6804 mm
23 Turning Radius to Outside of Tires	6761 mm	6761 mm	6761 mm
24 Turning Radius to Inside of Tires	3853 mm	3853 mm	3853 mm
25 Width Over Tires – Maximum (unloaded)	2991 mm	2991 mm	2991 mm
Width Over Tires – Maximum (loaded)	3009 mm	3009 mm	3009 mm
26 Tread Width	2230 mm	2230 mm	2230 mm

*Standard and High Lift are with 4.8 m³ general purpose pin on bucket with BOCE (see Operating Specifications for other buckets). Extended Capacity is with a 4.9 m³ general purpose pin on bucket with BOCE (see Operating Specifications for other buckets).

†Dimensions are listed in Operating Specifications charts.

All height and tire related dimensions are with Michelin 26.5R25 XHA2 L3 tires (see Tire Option Chart for other tires.) "Width Over Tires" dimensions are over the bulge and include growth.

All height and tire related dimensions are with Michelin 23.5R25 XHA2 L3 radial tires (see Tire Option Chart for other tires.) "Width Over Tires" dimensions are over the bulge and include growth.

966L/972L Wheel Loaders Specifications

966L Tire Option Chart (Compared to Michelin XHA2 L3)

Tire Brand	Michelin	Michelin	Michelin	Bridgestone	Bridgestone	Bridgestone	Bridgestone	Flexport	Flexport	Triangle
Tire Size	26.5R25	26.5R25	26.5R25	26.5R25	26.5R25	26.5R25	775/65R29	70×14×28 (26.5×25)	70×14×28 (26.5×25)	26.5R25
Tread Type	L-4	L-5	L-5	L-3	L-4	L-5	L-3	—	—	L-3
Tread Pattern	XLDD1	XLDD2	XMINED2	VJT	VSNT	VSDL	VTS	OTR	SMOOTH	TB516
Width over Tires – Maximum (unloaded)*	2987 mm	2986 mm	2970 mm	2982 mm	2973 mm	2874 mm	3080 mm	2955 mm	2896 mm	2971 mm
Width over Tires – Maximum (loaded)*	3019 mm	3011 mm	2994 mm	3016 mm	2993 mm	2900 mm	3101 mm	2972 mm	2915 mm	2999 mm
Change in Vertical Dimensions (average of front and rear)	44 mm	39 mm	53 mm	15 mm	25 mm	50 mm	17 mm	59 mm	52 mm	24 mm
Change in Horizontal Reach	-36 mm	-34 mm	-32 mm	-3 mm	-24 mm	-29 mm	-5 mm	-23 mm	-13 mm	-9 mm
Change in Clearance Circle (radius) to Outside of Tires	5 mm	1 mm	-7 mm	3 mm	-8 mm	-54 mm	46 mm	-19 mm	-47 mm	-5 mm
Change in Clearance Circle (radius) to Inside of Tires	-5 mm	-1 mm	7 mm	-3 mm	8 mm	54 mm	-46 mm	19 mm	47 mm	5 mm
Change in Operating Weight (without Ballast)	420 kg	716 kg	1068 kg	164 kg	624 kg	1136 kg	856 kg	3287 kg	3764 kg	100 kg

*Width over tire bulge and includes tire growth.

Changes Specific to the 966L

Tire Brand	Michelin	Michelin	Michelin	Bridgestone	Bridgestone	Bridgestone	Bridgestone	Flexport	Flexport	Triangle
Tire Size	26.5R25	26.5R25	26.5R25	26.5R25	26.5R25	26.5R25	775/65R29	70×14×28 (26.5×25)	70×14×28 (26.5×25)	26.5R25
Tread Type	L-4	L-5	L-5	L-3	L-4	L-5	L-3	—	—	L-3
Tread Pattern	XLDD1	XLDD2	XMINED2	VJT	VSNT	VSDL	VTS	OTR	SMOOTH	TB516
Change in Static Tipping Load – Straight	303 kg	517 kg	771 kg	118 kg	451 kg	821 kg	618 kg	2375 kg	2719 kg	72 kg
Change in Static Tipping Load – Articulated	271 kg	461 kg	688 kg	106 kg	402 kg	732 kg	551 kg	2118 kg	2425 kg	64 kg

966L/972L Wheel Loaders Specifications

972L Tire Option Chart (Compared to Michelin XHA2 L3)

Tire Brand	Michelin	Michelin	Michelin	Bridgestone	Bridgestone	Bridgestone	Bridgestone	Flexport	Flexport	Triangle
Tire Size	26.5R25	26.5R25	26.5R25	26.5R25	26.5R25	26.5R25	775/65R29	70×14×28 (26.5×25)	70×14×28 (26.5×25)	26.5R25
Tread Type	L-4	L-5	L-5	L-3	L-4	L-5	L-3	—	—	L-3
Tread Pattern	XLDD1	XLDD2	XMINED2	VJT	VSNT	VSDL	VTS	OTR	SMOOTH	TB516
Width over Tires – Maximum (unloaded)*	2987 mm	2986 mm	2970 mm	2982 mm	2973 mm	2874 mm	3080 mm	2955 mm	2896 mm	2984 mm
Width over Tires – Maximum (loaded)*	3019 mm	3015 mm	2998 mm	3016 mm	2993 mm	2900 mm	3101 mm	2972 mm	2915 mm	3006 mm
Change in Vertical Dimensions (average of front and rear)	43 mm	38 mm	51 mm	15 mm	25 mm	50 mm	17 mm	59 mm	52 mm	20 mm
Change in Horizontal Reach	-36 mm	-34 mm	-31 mm	-3 mm	-24 mm	-29 mm	-5 mm	-23 mm	-13 mm	-9 mm
Change in Clearance Circle to Outside of Tires	3 mm	1 mm	-7 mm	3 mm	-8 mm	-54 mm	46 mm	-19 mm	-47 mm	-5 mm
Change in Clearance Circle to Inside of Tires	-3 mm	-1 mm	7 mm	-3 mm	8 mm	54 mm	-46 mm	19 mm	47 mm	5 mm
Change in Operating Weight (without Ballast)	420 kg	716 kg	1068 kg	164 kg	624 kg	1136 kg	856 kg	3287 kg	3764 kg	100 kg

*Width over tire bulge and includes tire growth.

Changes Specific to the 966L

Tire Brand	Michelin	Michelin	Michelin	Bridgestone	Bridgestone	Bridgestone	Bridgestone	Flexport	Flexport	Triangle
Tire Size	26.5R25	26.5R25	26.5R25	26.5R25	26.5R25	26.5R25	775/65R29	70×14×28 (26.5×25)	70×14×28 (26.5×25)	26.5R25
Tread Type	L-4	L-5	L-5	L-3	L-4	L-5	L-3	—	—	L-3
Tread Pattern	XLDD1	XLDD2	XMINED2	VJT	VSNT	VSDL	VTS	OTR	SMOOTH	TB516
Change in Static Tipping Load – Straight	283 kg	482 kg	719 kg	110 kg	420 kg	764 kg	576 kg	2212 kg	2533 kg	67 kg
Change in Static Tipping Load – Articulated	252 kg	429 kg	640 kg	98 kg	374 kg	680 kg	513 kg	1969 kg	2255 kg	60 kg

966L/972L Wheel Loaders Specifications

966L Operating Specifications with Buckets

Linkage		Standard Linkage						High Lift Linkage Change**
Bucket Type		General Purpose – Pin On						
Edge Type		Bolt-On Cutting Edges	Teeth and Segments	Bolt-On Cutting Edges	Teeth and Segments	Bolt-On Cutting Edges	Teeth and Segments	
Capacity – Rated	m ³	3.8	3.8	4.0	4.0	4.2	4.2	
Capacity – 110%	m ³	4.2	4.2	4.4	4.4	4.6	4.6	
Width	mm	3220	3271	3220	3271	3220	3271	
16 † Dump Clearance at Maximum Lift and 45° Discharge	mm	3067	2915	3058	2905	2991	2837	558
17 † Reach at Maximum Lift and 45° Discharge	mm	1292	1432	1299	1438	1353	1490	-24
Reach at Level Lift Arm and Bucket Level	mm	2704	2908	2715	2920	2803	3008	404
A † Digging Depth	mm	124	124	124	124	124	124	-25
12 † Overall Length	mm	8651	8876	8663	8888	8750	8975	821
B † Overall Height with Bucket at Maximum Lift	mm	5788	5788	5902	5902	5902	5902	559
Loader Clearance Circle Radius with Bucket at Carry Position	mm	7487	7571	7490	7574	7511	7597	469
Static Tipping Load, Straight (With Tire Deflection)*	kg	16 917	16 734	16 900	16 716	16 699	16 514	59
Static Tipping Load, Straight (No Tire Deflection)*	kg	18 045	17 860	18 037	17 851	17 828	17 641	-25
Static Tipping Load, Articulated (With Tire Deflection)*	kg	14 894	14 711	14 873	14 689	14 686	14 501	-112
Static Tipping Load, Articulated (No Tire Deflection)*	kg	16 029	15 844	16 017	15 831	15 822	15 636	-180
Breakout Force	kN	187	185	185	183	173	171	-14
Operating Weight*	kg	23 112	23 250	23 164	23 302	23 220	23 358	1612

*Static tipping loads and operating weights shown are based on a machine configuration with Michelin 26.5R25 XHA2 L3 radial tires, full fluids, operator, standard counterweight, cold start, roading fenders, Product Link, open/open axles (front/rear), power train guard, secondary steering and sound suppression.

(With Tire Deflection) Full compliance to ISO 14397-1:2007 Sections 1 thru 6, which requires 2% verification between calculations and testing.

(No Tire Deflection) Compliance to ISO 14397-1:2007 Sections 1 thru 5.

**Maximum values.

†Illustration shown with Dimension charts.

966L/972L Wheel Loaders Specifications

966L Operating Specifications with Buckets

Linkage	Bucket Type	Standard Linkage				High Lift Linkage Change**
		Rock – Pin On		Material Handling – Pin On		
Edge Type		Bolt-On Cutting Edges	Teeth and Segments	Bolt-On Cutting Edges	Teeth and Segments	
Capacity – Rated	m ³	3.4	3.4	4.2	4.2	
Capacity – 110%	m ³	3.7	3.7	4.6	4.6	
Width	mm	3252	3252	3220	3271	
16† Dump Clearance at Maximum Lift and 45° Discharge	mm	3093	2995	2949	2787	558
17† Reach at Maximum Lift and 45° Discharge	mm	1419	1541	1245	1372	-24
Reach at Level Lift Arm and Bucket Level	mm	2783	2939	2774	2978	404
A† Digging Depth	mm	99	99	124	124	-25
12† Overall Length	mm	8740	8901	8721	8946	821
B† Overall Height with Bucket at Maximum Lift	mm	5815	5815	5901	5901	559
Loader Clearance Circle Radius with Bucket at Carry Position	mm	7530	7573	7504	7589	469
Static Tipping Load, Straight (With Tire Deflection)*	kg	17 120	17 050	16 622	16 439	59
Static Tipping Load, Straight (No Tire Deflection)*	kg	18 262	18 191	17 731	17 546	-25
Static Tipping Load, Articulated (With Tire Deflection)*	kg	15 053	14 983	14 623	14 439	-112
Static Tipping Load, Articulated (No Tire Deflection)*	kg	16 204	16 133	15 740	15 555	-180
Breakout Force	kN	186	185	177	175	-14
Operating Weight*	kg	24 007	24 059	23 217	23 355	1612

*Static tipping loads and operating weights shown are based on a machine configuration with Michelin 26.5R25 XHA2 L3 radial tires, full fluids, operator, standard counterweight, cold start, roading fenders, Product Link, open/open axles (front/rear), power train guard, secondary steering and sound suppression.

(With Tire Deflection) Full compliance to ISO 14397-1:2007 Sections 1 thru 6, which requires 2% verification between calculations and testing.

(No Tire Deflection) Compliance to ISO 14397-1:2007 Sections 1 thru 5.

**Maximum values.

†Illustration shown with Dimension charts.

966L/972L Wheel Loaders Specifications

966L Operating Specifications with Buckets – Aggregate Handler

Package		Aggregate Handler		
Bucket Type		General Purpose – Pin On		
Edge Type		Bolt-On Cutting Edges	Bolt-On Cutting Edges	Bolt-On Cutting Edges
Capacity – Rated	m ³	4.2	4.4	4.6
Capacity – Rated at 110% Fill Factor	m ³	4.6	4.8	5.1
Width	mm	3220	3220	3220
16 † Dump Clearance at Maximum Lift and 45° Discharge	mm	2991	2979	2977
17 † Reach at Maximum Lift and 45° Discharge	mm	1353	1366	1365
Reach at Level Lift Arm and Bucket Level	mm	2803	2821	2822
A † Digging Depth	mm	124	124	124
12 † Shipping Length (with Bucket)	mm	8798	8816	8817
B † Overall Height with Bucket at Maximum Lift	mm	5902	5912	5874
Loader Clearance Circle with Bucket at Carry Position	mm	7511	7516	7516
Static Tipping Load, Straight (With Tire Deflection)*	kg	18 303	18 236	18 307
Static Tipping Load, Straight (No Tire Deflection)*	kg	19 570	19 497	19 601
Static Tipping Load, Articulated (With Tire Deflection)*	kg	16 044	15 986	16 036
Static Tipping Load, Articulated (No Tire Deflection)*	kg	17 325	17 261	17 343
Breakout Force	kN	173	171	170
Operating Weight*	kg	23 915	23 904	23 955

*Static tipping loads and operating weights shown are based on a machine configuration with Michelin 26.5R25 XHA2 L3 radial tires, full fluids, operator, aggregate counterweight, cold start, roading fenders, Product Link, open/open axles (front/rear), power train guard, secondary steering and sound suppression. If a rock bucket is added, those values are with Michelin 26.5R25 XLDD2 L5 tires.

(With Tire Deflection) Full compliance to ISO 14397-1:2007 Sections 1 thru 6, which requires 2% verification between calculations and testing.

(No Tire Deflection) Compliance to ISO 14397-1:2007 Sections 1 thru 5.

†Illustration shown with Dimension charts.

Aggregate Handler configuration is not compatible with teeth and segments, tips, rock buckets, high lift, and L5 tires.

Other buckets are available and offerings vary by region. Consult your local Cat dealer for further details.

966L/972L Wheel Loaders Specifications

972L Bucket Fill Factors and Selection Chart

The bucket size must be chosen based on the density of the material and on the expected fill factor. The Cat Performance Series Buckets with longer floor, larger bucket opening, increased repository angle, rounded side boards and integrated spill guard, demonstrate fill factors significantly higher than previous generation or non Cat buckets. The actual volume handled by the machine is thus often larger than the rated capacity.

Loose Material		Material Density	Fill Factor (%)*
Earth/Clay		1500-1700 kg/m ³	115
Sand and Gravel		1500-1700 kg/m ³	115
Aggregate:	25-76 mm	1600-1700 kg/m ³	110
	19 mm and smaller	1800 kg/m ³	105
Rock:	76 mm and larger	1600 kg/m ³	100

*As a % of ISO rated capacity.

Note: Fill Factors achieved will also depend on whether the product is washed or not washed.

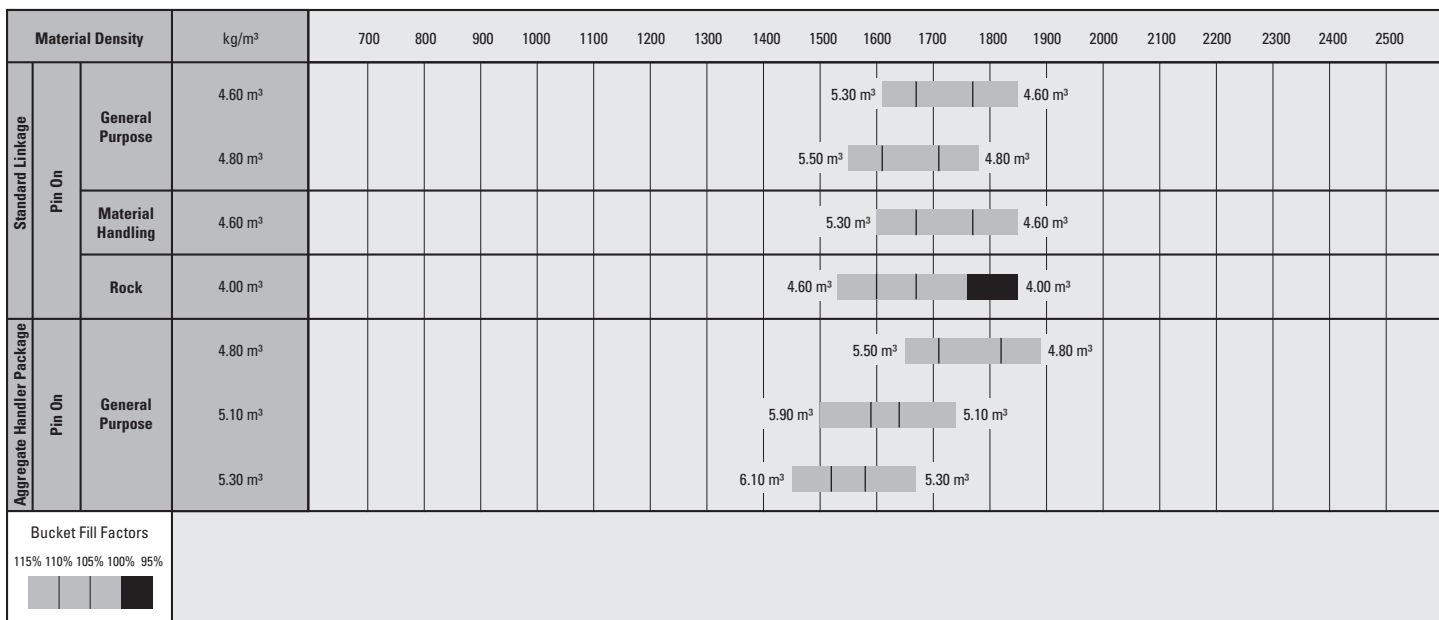

Note: All buckets are showing Bolt-On Edges.

966L/972L Wheel Loaders Specifications

972L Operating Specifications with Buckets

Linkage		Standard Linkage				High Lift Linkage Change**
Bucket Type		General Purpose – Pin On				
Edge Type		Bolt-On Cutting Edges	Teeth and Segments	Bolt-On Cutting Edges	Teeth and Segments	
Capacity – Rated	m ³	4.6	4.6	4.8	4.8	
Capacity – 110%	m ³	5.1	5.1	5.3	5.3	
Width	mm	3220	3271	3220	3271	
16† Dump Clearance at Maximum Lift and 45° Discharge	mm	3187	3033	3154	2999	335
17† Reach at Maximum Lift and 45° Discharge	mm	1328	1465	1357	1493	23
Reach at Level Lift Arm and Bucket Level	mm	2969	3174	3014	3219	273
A† Digging Depth	mm	103	103	103	103	-4
12† Overall Length	mm	9270	9494	9315	9539	336
B† Overall Height with Bucket at Maximum Lift	mm	6195	6195	6031	6031	336
Loader Clearance Circle Radius with Bucket at Carry Position	mm	7596	7685	7608	7697	324
Static Tipping Load, Straight (With Tire Deflection)*	kg	18 477	18 293	18 502	18 318	-1569
Static Tipping Load, Straight (No Tire Deflection)*	kg	19 724	19 537	19 755	19 567	-1727
Static Tipping Load, Articulated (With Tire Deflection)*	kg	16 135	15 950	16 164	15 978	-1402
Static Tipping Load, Articulated (No Tire Deflection)*	kg	17 387	17 200	17 421	17 233	-1574
Breakout Force	kN	202	201	196	194	-5
Operating Weight*	kg	24 969	25 106	24 897	25 034	85

*Static tipping loads and operating weights shown are based on a machine configuration with Michelin 26.5R25 XHA2 L3 radial tires, full fluids, operator, standard counterweight, cold start, roading fenders, Product Link, open/open axles (front/rear), power train guard, secondary steering and sound suppression.

(With Tire Deflection) Full compliance to ISO 14397-1:2007 Sections 1 thru 6, which requires 2% verification between calculations and testing.

(No Tire Deflection) Compliance to ISO 14397-1:2007 Sections 1 thru 5.

**Maximum values.

†Illustration shown with Dimension charts.

966L/972L Wheel Loaders Specifications

972L Operating Specifications with Buckets

Linkage	Bucket Type	Standard Linkage		Standard Linkage		High Lift Linkage Change**
		Material Handling – Pin On		Rock – Pin On		
Edge Type		Bolt-On Cutting Edges	Teeth and Segments	Bolt-On Cutting Edges	Teeth and Segments	
Capacity – Rated	m ³	4.6	4.6	4.0	4.0	
Capacity – 110%	m ³	5.1	5.1	4.4	4.4	
Width	mm	3220	3271	3252	3252	
16† Dump Clearance at Maximum Lift and 45° Discharge	mm	3120	2957	3203	3112	335
17† Reach at Maximum Lift and 45° Discharge	mm	1251	1378	1428	1536	23
Reach at Level Lift Arm and Bucket Level	mm	2979	3184	3038	3179	273
A† Digging Depth	mm	103	103	74	74	-4
12† Overall Length	mm	9280	9504	9351	9495	336
B† Overall Height with Bucket at Maximum Lift	mm	6162	6162	6129	6129	336
Loader Clearance Circle Radius with Bucket at Carry Position	mm	7599	7688	7640	7681	324
Static Tipping Load, Straight (With Tire Deflection)*	kg	18 431	18 248	18 999	18 929	-1569
Static Tipping Load, Straight (No Tire Deflection)*	kg	19 659	19 473	20 279	20 208	-1727
Static Tipping Load, Articulated (With Tire Deflection)*	kg	16 100	15 915	16 589	16 518	-1402
Static Tipping Load, Articulated (No Tire Deflection)*	kg	17 333	17 146	17 873	17 802	-1574
Breakout Force	kN	201	199	204	204	-5
Operating Weight*	kg	24 942	25 080	25 729	25 780	85

*Static tipping loads and operating weights shown are based on a machine configuration with Michelin 26.5R25 XHA2 L3 radial tires, full fluids, operator, standard counterweight, cold start, roading fenders, Product Link, open/open axles (front/rear), power train guard, secondary steering and sound suppression.

(With Tire Deflection) Full compliance to ISO 14397-1:2007 Sections 1 thru 6, which requires 2% verification between calculations and testing.

(No Tire Deflection) Compliance to ISO 14397-1:2007 Sections 1 thru 5.

**Maximum values.

†Illustration shown with Dimension charts.

966L/972L Wheel Loaders Specifications

972L Operating Specifications with Buckets – Aggregate Handler

Linkage		Aggregate Handler		
Bucket Type		General Purpose – Pin On		
Edge Type		Bolt-On Cutting Edges	Bolt-On Cutting Edges	Bolt-On Cutting Edges
Capacity – Rated	m ³	4.8	5.1	5.3
Capacity – 110%	m ³	5.3	5.6	5.8
Width	mm	3220	3357	3357
16 † Dump Clearance at Maximum Lift and 45° Discharge	mm	3154	3127	3100
17 † Reach at Maximum Lift and 45° Discharge	mm	1357	1375	1399
Reach at Level Lift Arm and Bucket Level	mm	3014	3046	3083
A † Digging Depth	mm	103	108	108
12 † Overall Length	mm	9001	9037	9074
B † Overall Height with Bucket at Maximum Lift	mm	6031	6235	6272
Loader Clearance Circle Radius with Bucket at Carry Position	mm	7608	7681	7691
Static Tipping Load, Straight (With Tire Deflection)*	kg	19 698	19 316	19 242
Static Tipping Load, Straight (No Tire Deflection)*	kg	21 060	20 669	20 600
Static Tipping Load, Articulated (With Tire Deflection)*	kg	17 179	16 799	16 726
Static Tipping Load, Articulated (No Tire Deflection)*	kg	18 550	18 165	18 098
Breakout Force	kN	196	190	185
Operating Weight*	kg	25 481	25 790	25 832

*Static tipping loads and operating weights shown are based on a machine configuration with Michelin 26.5R25 XHA2 L3 radial tires, full fluids, operator, standard counterweight, cold start, roading fenders, Product Link, open/open axles (front/rear), power train guard, secondary steering and sound suppression.

(With Tire Deflection) Full compliance to ISO 14397-1:2007 Sections 1 thru 6, which requires 2% verification between calculations and testing.

(No Tire Deflection) Compliance to ISO 14397-1:2007 Sections 1 thru 5.

**Maximum values.

†Illustration shown with Dimension charts.

Standard Equipment

Standard equipment may vary. Consult your Cat dealer for details.

OPERATOR ENVIRONMENT

- Cab, pressurized and sound suppressed (ROPS/FOPS)
- Viscous mounts
- Rear vision camera within multi-function 18 cm color LCD touch-screen display (*capability for displaying machine status, setting and health parameters*)
- EH controls, SAL (single axis lever) lift and tilt function
- Steering, steering wheel
- Radio ready (entertainment) includes antenna, speakers and converter (12V, 10-amp)
- Air conditioner, heater, and defroster
- EH parking brake
- Beverage holders (2) with storage compartment for cell phone/MP3 player
- Bucket/work tool function lockout
- Coat hook
- Cab air filter
- Ergonomic cab access ladders and handrails
- Horn, electric
- Light, two dome (cab)
- Mirrors, rearview external with integrated spot mirrors
- Post mounted membrane 16 switch keypad
- Two receptacles, 12V
- Seat, Cat Comfort (cloth) air suspension
- Seat belt, 51 mm retractable
- Sun visor, front
- Wet-arm wipers/washers front and rear, intermittent front wiper
- Window, sliding (left and right sides)

COMPUTERIZED MONITORING SYSTEM

- With following gauges:
 - Speedometer/tachometer
 - Digital gear range indicator
 - Temperature: engine coolant, hydraulic oil, transmission oil
 - Fuel level

- With following warning indicators:
 - Temperature: axle oil, engine intake manifold
 - Pressure: engine oil, fuel pressure hi/low, primary steering oil, service brake oil
 - Battery voltage hi/low
 - Engine air filter restriction
 - Hydraulic oil filter restriction
 - Hydraulic oil low
 - Parking brake
 - Transmission filter bypass

ELECTRICAL AND LIGHTING

- Batteries (2), maintenance free 1,400 CCA
- Ignition key; start/stop switch
- Starter, electric, heavy duty
- Starting and charging system (24V)
- Lighting system:
 - Four halogen work lights (cab mounted)
 - Two halogen rear vision lights (hood mounted)
- Alarm, back-up
- Alternator, 145-amp brushed
- Main disconnect switch
- Receptacle start (cables not included)

CAT CONNECT TECHNOLOGIES

- Link technologies: Product Link
- Detect technologies: rear vision camera

POWER TRAIN

- Engine, Cat C9.3 ACERT – meets China Nonroad Stage III emission standards equivalent to Tier 3/Stage IIIA, or emissions equivalent to Tier 2/Stage II emissions standards
- Fuel priming pump (electric)
- Fuel/water separator
- Precleaner, engine air intake
- Productive Economy Mode
- Transmission, automatic planetary power shift (4F/4R)
- Torque converter, locking clutch with free wheel stator
- Switch, transmission neutralizer lockout
- Axles, open differential front and rear axles
- Brakes, full hydraulic enclosed wet-disc with Integrated Braking System (IBS)
- Brake wear indicators
- Parking brake, disc and caliper
- Fan, radiator, electronically controlled, hydraulically driven, temperature sensing, on demand

LINKAGE

- Linkage, Z-bar, cast crosstube/tilt lever
- Kickout, lift and tilt, automatic (adjustable in cab)

HYDRAULICS

- Hydraulic system, load sensing
- Steering, load sensing
- Remote diagnostic pressure taps
- Hoses, Cat XT™
- Couplings, Cat O-ring face seal
- Hydraulic oil cooler (swing out)
- Oil sampling valves

FLUIDS

- Premixed extended life coolant with freeze protection to -34° C

OTHER STANDARD EQUIPMENT

- Toolbox
- Hood, non-metallic power tilting
- Service centers (electrical and hydraulic)
- Auto idle shutdown
- Fenders, front
- Ecology drains for engine, transmission, and hydraulics
- Grill, airborne debris
- Filters: fuel, engine air, engine oil, hydraulic oil, transmission
- Grease zerks
- Hitch, drawbar with pin
- Precleaner rain cap
- Sight gauges: engine coolant, hydraulic oil, and transmission oil level
- Vandalism protection caplocks

966L/972L Optional Equipment

Optional Equipment

Optional equipment may vary. Consult your Cat dealer for details.

OPERATOR ENVIRONMENT

- Cover, HVAC metallic
- EH controls, SAL 3rd function
- EH controls, joystick lift and tilt
 - Additional integrated roller switches for 3rd function
- Mirrors, heated rearview external with integrated spot mirrors
- Precleaner, HVAC
- Radio, AM/FM/USB/MP3 Bluetooth™
- Radio, AM/FM/CD/USB/MP3 Bluetooth
- Radio, CB ready
- Seat, heated air suspension
- Seat belt, 76 mm retractable, with indicator
- Roof, metallic
- Steering, secondary
- Sun visor, rear
- Windows, rubber mounted
- Windows, with front guard
- Windows, with full guards front, rear and sides
- Full time rear vision display Work Area Vision System (WAVS)

ELECTRICAL AND LIGHTING

- Four additional auxiliary halogen cab mounted work lights or
- Two additional auxiliary front HI LED and two additional auxiliary rear LED cab mounted work lights with two LED work lights in the radiator grill and LED front turn signals also includes replacement of the standard four halogen cab mounted work lights with four LED work lights (the standard offering and only roading light available is the halogen roading light)
- Warning amber strobe beacon
- Two LED stop, turn, tail lights

STARTERS, BATTERIES, AND ALTERNATORS

- Cold start – 240V

CAT CONNECT TECHNOLOGIES

- Link technologies:
 - VIMS™
- Payload technologies:
 - Cat Production Measurement 2.0 (Cat PM)
 - Printer, Cat Production Measurement
 - Aggregate Autodig
- Detect technologies:
 - Cat Rear Object Detection
- Machine Security System

POWER TRAIN

- Axles
 - Automatic front/rear differential locks
 - Axle oil cooler
 - Ecology drains
 - Extreme temperature seals
 - Seal guards
- Fan, VPF (variable pitch fan), automatic and manual control
- Radiator, high debris with wider fin spacing

LINKAGE

- High lift
- Forestry
- Quick coupler ready
- Autolube

WORK TOOLS

- Performance Series buckets
- Fusion quick coupler
- Forks, pallet
- Forks, logging

HYDRAULICS

- 3rd function with Ride Control
 - Standard linkage
 - High lift linkage
 - Forestry linkage
- Ride control, 2V

FLUIDS

- Premixed extended life coolant with freeze protection to –50° C

OTHER OPTIONAL EQUIPMENT

- Cat Autolube System
- Fenders, roading
- Guard, power train
- Precleaner, turbine
- Precleaner, trash
- Platform, window washing
- Cold weather package
 - Transmission filter bypass
 - Fan pump bypass
 - Jacket water or engine block heater
 - Ether aid ready

OTHER OPTIONAL CONFIGURATIONS

- Industrial and Waste Handler
- Steel Mill
- Block Handler (966L)
- Forestry (966L)
- Port and Harbor (966L)

For more complete information on Cat products, dealer services, and industry solutions, visit us on the web at www.cat.com

© 2017 Caterpillar
All rights reserved

Materials and specifications are subject to change without notice. Featured machines in photos may include additional equipment. See your Cat dealer for available options.

CAT, CATERPILLAR, SAFETY.CAT.COM, their respective logos, "Caterpillar Yellow" and the "Power Edge" trade dress, as well as corporate and product identity used herein, are trademarks of Caterpillar and may not be used without permission.

VisionLink is a trademark of Trimble Navigation Limited, registered in the United States and in other countries.

AEHQ7819-03
Replaces AEHQ7819-02
(Afr-ME, China, SE Asia,
S Am, Turkey and CIS)

