

# 2500 Series Industrial Engine

2506J-E15TA EU Stage V/U.S. EPA Tier 4 Final

2506EA-E15TA China Nonroad Stage IV

354-433 kW (475-580 hp)

The ability to power your machine line-up with one engine supplier is truly achievable with Perkins. We have introduced a platform of 9-18 litre industrial engines that completes our market-leading industrial power range and covers 8.2-597 kW (11-800 hp).

This model is a turbocharged, air-to-air chargecooled, 15.2 litre, 6 cylinder product capable of producing 433 kW (580 hp).

The 2506J-E15TA is certified to EU Stage V/U.S. EPA Tier 4 Final and other equivalent certifications. The 2506EA-E15TA is certified to China Nonroad (NR) Stage IV. Identical performance across these certifications provides global customers a single source solution, streamlining design, installation, and service processes.

To support the demands of your machine installation we offer a choice of engine configurations and options. The robust technology allows you to integrate these engines into your equipment with the minimum of re-engineering.

Perkins has developed a reputation for designing and building reliable and durable engines for the most demanding applications. Choosing Perkins as your engine supplier means your development costs and your installation, operation, and service routines are commonised.

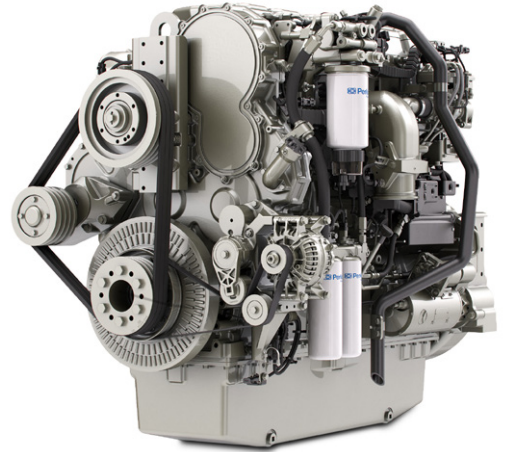

Specification		
Number of cylinders	6 vertical in-line	
Bore and stroke	137 x 171 mm	5.4 x 6.7 in
Displacement	15.2 litres	928 cubic in
Aspiration	Turbocharged aftercooled	
Cycle	4 stroke	
Combustion system	Direct injection	
Compression ratio	17.0:1	
Rotation	Counterclockwise, viewed on flywheel	
Total lubricating capacity	38-72 litres	10-19 US gal
Cooling system	Liquid	
Total coolant capacity	27 litres	7 US gal

[www.perkins.com](http://www.perkins.com)

Photographs are for illustrative purposes only and may not reflect final specification. All information in this document is substantially correct at time of printing and may be altered subsequently. Final weight and dimensions will depend on completed specification.

Publication No. PN3115/08/21 Produced in England ©2017 Perkins Engines Company Limited

 **Perkins®**

THE HEART OF EVERY GREAT MACHINE

# 2500 Series Industrial Engine

2506J-E15TA EU Stage V/U.S. EPA Tier 4 Final

2506EA-E15TA China Nonroad Stage IV

354-433 kW (475-580 hp)

## Features and benefits

### Dependable power

- World-class manufacturing capability and processes coupled with proven core engine designs assure reliability, quiet operation and many hours of productive life

### High performance

- Simple and efficient turbocharger provides optimal air management and improved fuel efficiency

### Lifetime of low cost

- Fuel consumption optimised to match operating cycles of a wide range of equipment and applications
- Minimum 5,000 hour diesel particulate filter (DPF) ash service and capability of 500 hour oil change intervals enable low-cost maintenance

### Package size

- Exceptional power density enables standardisation across numerous applications. Multiple installation options available to minimise total package size

### Local support, global coverage

- Perkins recognise that the customer relationship is important to machine manufacturers and we can offer a range of flexible solutions to help provide appropriate support, either to the OEM's network or directly to the machine customer
- With highly trained Perkins distributors in thousands of communities in over 180 countries, you are never far away from expert product knowledge, genuine parts and a range of advanced diagnostic technology for keeping your engine in peak condition
- To find your local distributor: [www.perkins.com/distributor](http://www.perkins.com/distributor)

[www.perkins.com](http://www.perkins.com)

Photographs are for illustrative purposes only and may not reflect final specification.  
All information in this document is substantially correct at time of printing and may be altered subsequently.  
Final weight and dimensions will depend on completed specification.

Publication No. PN3115/08/21 Produced in England ©2021 Perkins Engines Company Limited

 **Perkins**<sup>®</sup>

THE HEART OF EVERY GREAT MACHINE

# 2500 Series Industrial Engine

2506J-E15TA EU Stage V/U.S. EPA Tier 4 Final

2506EA-E15TA China Nonroad Stage IV

354-433 kW (475-580 hp)

## Technical information

### Air inlet

- Turbocharged aftercooled

### Control system

- Full electronic control system with all system functions controlled from a single, engine mounted electronic control module (ECM)\*
- All connectors and wiring looms waterproof and designed to withstand harsh off-highway environments
- Flexible and configurable software features and well supported SAE J1939 CAN bus enables highly integrated machines

### Cooling system

- Vertical outlet thermostat housing, centrifugal water pump
- Detailed guidance on cooling system design and validation available to ensure machine reliability

### Flywheel and housing

- Wide choice of drivetrain interfaces, SAE0 and SAE1 configurations

### Fuel and fuel system

- Mechanical Unit Injector Fuel system, controlled electronically
- Industrial technology requires Ultra Low Sulphur Diesel fuel (ULSD, not to exceed 15 ppm sulphur), in addition to ultra low sulphur diesel oils, for use in Stage V/Tier 4 Final and China NR IV engines. These cleaner fuels and oils help reduce ash and maintain service intervals
- B20 biodiesel capability adds even greater sustainability where desired or required

### Oil system

- Choice of sumps for different applications
- Open crankcase ventilation system with fumes disposal (optional OCV filter system)
- Oil cooler, oil filler, oil filter, oil dipstick, oil pump (gear-driven)

### Power take-off

- SAE1 power take-off available with optional SAE A, SAE B and SAE C power take-off drives
- Engine power can also be taken from the front of the engine on some applications

\* All China Nonroad IV and new EU Stage V / U.S. EPA Tier 4 Final installations should use the latest, single ECM version. An electronic control system consisting of three-units (one each mounted on the engine, aftertreatment, and pump electronic tank unit) exists for legacy installations certified to EU Stage V/U.S. EPA Tier 4 Final.

[www.perkins.com](http://www.perkins.com)

Photographs are for illustrative purposes only and may not reflect final specification. All information in this document is substantially correct at time of printing and may be altered subsequently. Final weight and dimensions will depend on completed specification.

Publication No. PN3115/08/21 Produced in England ©2021 Perkins Engines Company Limited

 **Perkins**<sup>®</sup>

THE HEART OF EVERY GREAT MACHINE

# 2500 Series Industrial Engine

2506J-E15TA EU Stage V/U.S. EPA Tier 4 Final

2506EA-E15TA China Nonroad Stage IV

354-433 kW (475-580 hp)

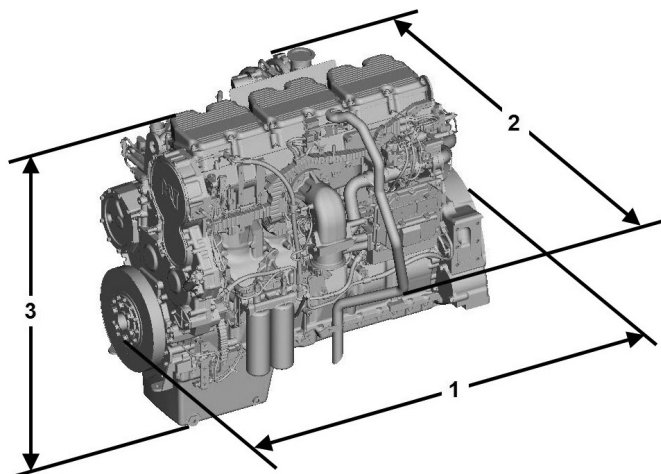

Aftertreatment dimensions and weight

1	Length	1438 mm	56.6 in
2	Width	955 mm	37.6 in
3	Height	1248 mm	49.1 in
	Weight (dry)	1542 kg	3395.5 lb

[www.perkins.com](http://www.perkins.com)

Photographs are for illustrative purposes only and may not reflect final specification. All information in this document is substantially correct at time of printing and may be altered subsequently. Final weight and dimensions will depend on completed specification.

Publication No. PN3115/08/21 Produced in England ©2021 Perkins Engines Company Limited

 **Perkins**<sup>®</sup>

THE HEART OF EVERY GREAT MACHINE

# 2500 Series Industrial Engine

2506J-E15TA EU Stage V/U.S. EPA Tier 4 Final

2506EA-E15TA China Nonroad Stage IV

354-433 kW (475-580 hp)

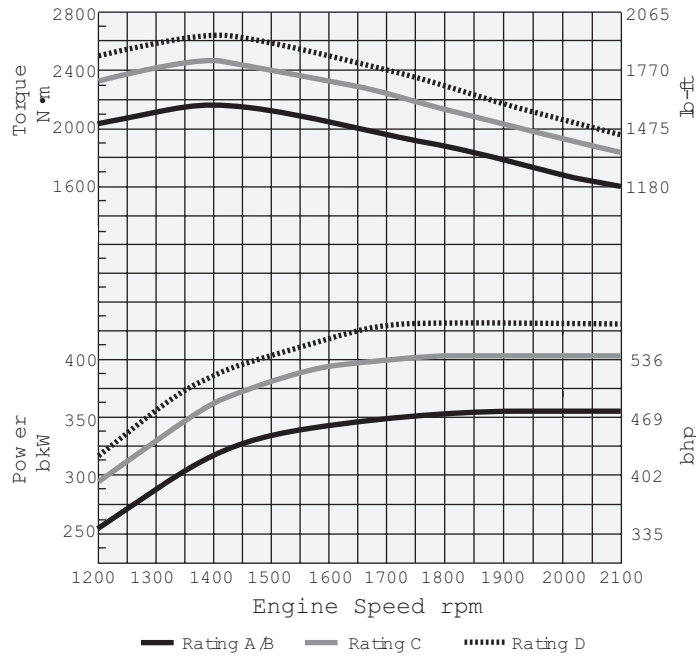

Speed rpm	Power kW	Power hp	Speed rpm	Torque Nm	Torque lb-ft	Rating type
2100	354	475	1400	2174	1604	A
2100	354	475	1400	2174	1604	B
2100	403	540	1400	2472	1823	C
2100	433	580	1400	2655	1958	D

## Rating definitions and conditions

**IND-A (Continuous)** for heavy duty service where the engine is operated at maximum power and speed up to 100% of the time without interruption or load cycling.

**IND-B** for service where power and/or speed are cyclic (time at full load not to exceed 80%).

**IND-C (Intermittent)** is the horsepower and speed capability of the engine where maximum power and/or speed are cyclic (time at full load not to exceed 50%).

**IND-D** for service where maximum power is required for periodic overloads (time at full load not to exceed 10% of the duty cycle).

## Rating conditions for diesel engines – greater than 7 litre

All rating conditions are based on SAE J1995, inlet air standard conditions of 99 kPa (29.31 in Hg) dry barometer and 25°C (77°F) temperature. Performance measured using a standard fuel with fuel gravity of 35° API having a lower heating value of 42,780 kJ/kg (18,390 btu/lb) when used at 29°C (84.2°F) with a density of 838.9 g/L.

# 2500 Series Industrial Engine

2506J-E15TA EU Stage V/U.S. EPA Tier 4 Final

2506EA-E15TA China Nonroad Stage IV

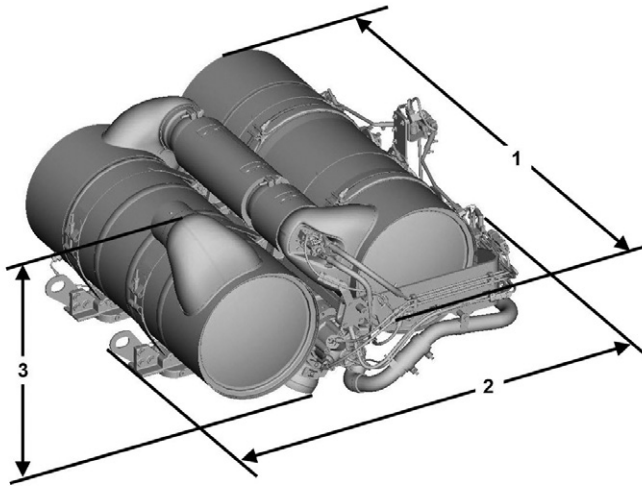

Aftertreatment dimensions and weight			
1	Length	1153 mm	45.4 in
2	Width	1112 mm	43.8 in
3	Height	652 mm	25.7 in
	Weight	268 kg	590.8 lb

## Aftertreatment

- DOC – Diesel Oxidation Catalyst
- DPF – Diesel Particulate Filter
- SCR - Selective Catalytic Reduction
- ECU - Aftertreatment Electronic Control Units
- SCR Auxiliaries - A range of fully validated and integrated Diesel Exhaust Fluid (DEF) tanks up to 93.7 litres, lines and accessory options are available

## Technology

The DPF technology chosen is a wall flow filter configuration that performs through the whole work cycle of the engine thus allowing it to work efficiently.

## Power

Using our advanced research and development techniques, we have perfectly matched the aftertreatment to the engine. The engine performance has then been optimised to give the maximum power and in normal operation, the regeneration is invisible to the operator.

## Mounting

Remote installation options provide OEM flexibility for many applications, including horizontal and vertical mounting.

## Regeneration

The active regeneration system maximises fuel efficiency during regeneration. Transparent regeneration for minimum downtime.