

1500 Series 1506D-E88TAG3 ElectropaK

U.S. EPA Tier 3 Emergency Stationary Engines only
276 kWm standby net power @ 1800 rpm

Building upon Perkins proven reputation within the power generation industry the Perkins® 1500 Series ElectropaK engines now fit even closer to our customer's needs.

The 1506D-E88TAG3 ElectropaK is a 6 cylinder, fully electronic, turbocharged, air-to-air charge cooled diesel engine. It is economical, quiet and reliable and provides the high performance that is demanded by our customers for their power generation needs.

Focusing on the Perkins common platform theme, changes to engine envelope dimensions and connection points have been kept to a minimum, making for easy installation across the ratings.



| Specification | | |
|----------------------------|------------------------------------|--------------|
| Number of cylinders | 6 vertical in-line | |
| Bore and stroke | 112 x 149 mm | 4.5 x 5.8 in |
| Displacement | 8.8 litres | 537 cubic in |
| Aspiration | Turbocharged aftercooled | |
| Cycle | 4 stroke | |
| Combustion system | Direct injection | |
| Compression ratio | 16.1:1 | |
| Rotation | Anti-clockwise, viewed on flywheel | |
| Total lubricating capacity | 41 litres | 10.8 US gal |
| Cooling system | Liquid | |

www.perkins.com

Photographs are for illustrative purposes only and may not reflect final specification.
All information in this document is substantially correct at time of printing and may be altered subsequently.
Final weight and dimensions will depend on completed specification.

Publication No. PN3110/12/16 Produced in England ©2016 Perkins Engines Company Limited

 **Perkins®**

THE HEART OF EVERY GREAT MACHINE

1500 Series 1506D-E88TAG3 ElectropaK

U.S. EPA Tier 3 Emergency Stationary Engines only

276 kWm standby net power @ 1800 rpm

Features and benefits

Dependable power

- The 1506D-E88TAG3 delivers greater productivity through an improved power to weight ratio
- The world-class power density has been achieved from an 8.8 litre turbocharged engine using a hydraulic actuated unit injection (HEUI) fuel system; making this engine robust for all markets due to its ability to cope with the variation of fuel quality around the world
- In its class, the 1506D-E88TAG3 has been designed to provide dependable power even in extreme ambient climates

Low operating costs

- Oil change service intervals are set at 500 hours as standard
- Designed to provide low cost of ownership, simple maintenance and reduced downtime
- Perkins provides warranty coverage commencing on the date of delivery of new engines to the first user for 12 months, with 24 months on major core engine components. Consult Perkins Engines Company for detailed information

World class product support

- Perkins experienced global network of distributors and dealers, fully trained engine experts deliver total service support around the clock, 365 days a year. They have a comprehensive suite of web based tools at their disposal, covering technical information, parts identification and ordering systems, all dedicated to maximising the productivity of your engine
- Perkins actively pursues product support excellence by insisting our distribution network invest in their territory to provide customers with a consistent quality of support across the globe
- Throughout the entire life of a Perkins engine, we provide access to genuine OE specification parts giving 100% reassurance that you receive the very best in terms of quality for lowest possible cost, wherever your Perkins powered machine is operating in the world
- To find your local distributor: www.perkins.com/distributor

www.perkins.com

Photographs are for illustrative purposes only and may not reflect final specification.
All information in this document is substantially correct at time of printing and may be altered subsequently.
Final weight and dimensions will depend on completed specification.

Publication No. PN3110/12/16 Produced in England ©2016 Perkins Engines Company Limited

 **Perkins**[®]

THE HEART OF EVERY GREAT MACHINE

1500 Series 1506D-E88TAG3 ElectropaK

U.S. EPA Tier 3 Emergency Stationary Engines only
276 kWm standby net power @ 1800 rpm

Technical information

Air inlet system

- Mounted air filter and turbocharger

Fuel system

- HEUI fuel system with full authority electronic control
- Electronic governing to ISO 8528-5 with stand-alone isochronous and load-sharing capabilities
- Fuel filter, fuel transfer pump, fuel priming pump
- Spin on primary, secondary and water filter separator

Lubrication system

- Wet full aluminium sump with filler and dipstick
- Full-flow spin-on filters
- Oil pump, gear driven

Cooling system

- Thermostatically controlled with belt driven, circulating pump and belt-drive fan
- Mounted belt driven pusher fan
- Radiator supplied loose with all guards and pipes
- Air-to-air charge cooler incorporated in radiator

Electrical equipment

- 24V starter motor and 24V, 45 amp alternator with DC output
- Electronic Control Module (ECM) mounted on engine with wiring looms and sensors

Flywheel and housing

- High inertia flywheel to SAE 1 J620 Size 355.6 mm (14 in)
- Aluminium SAE 1 flywheel housing

Mountings

- Front engine mounting bracket

www.perkins.com

Photographs are for illustrative purposes only and may not reflect final specification.
All information in this document is substantially correct at time of printing and may be altered subsequently.
Final weight and dimensions will depend on completed specification.

Publication No. PN3110/12/16 Produced in England ©2016 Perkins Engines Company Limited

 **Perkins**[®]

THE HEART OF EVERY GREAT MACHINE

1500 Series 1506D-E88TAG3 ElectropaK

U.S. EPA Tier 3 Emergency Stationary Engines only
276 kWm standby net power @ 1800 rpm

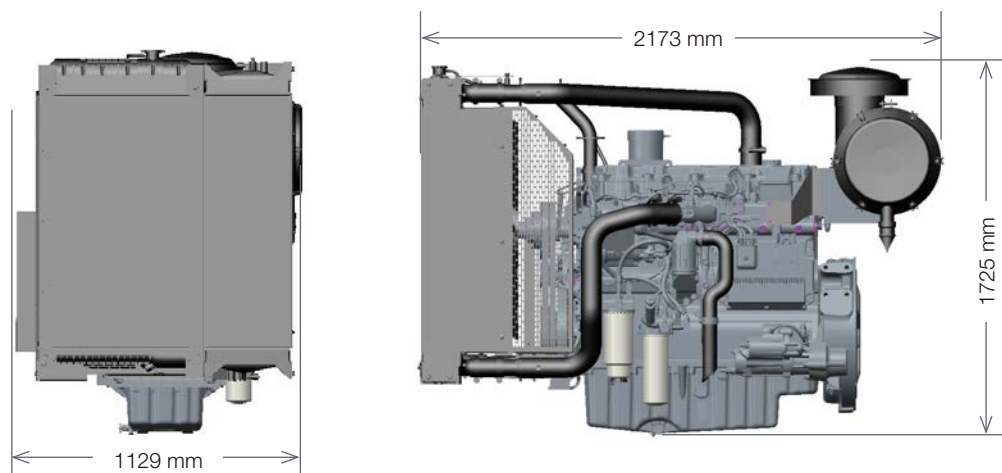

Engine package weights and dimensions

| Engine package weights and dimensions | | |
|---------------------------------------|---------|---------|
| Length (including air cleaner) | 2173 mm | 86 in |
| Width | 1129 mm | 45 in |
| Height | 1725 mm | 68 in |
| Weight (dry) | 1175 kg | 2590 lb |

www.perkins.com

Photographs are for illustrative purposes only and may not reflect final specification.
All information in this document is substantially correct at time of printing and may be altered subsequently.
Final weight and dimensions will depend on completed specification.

Publication No. PN3110/12/16 Produced in England ©2016 Perkins Engines Company Limited

 **Perkins**[®]

THE HEART OF EVERY GREAT MACHINE

1500 Series 1506D-E88TAG3 ElectropaK

U.S. EPA Tier 3 Emergency Stationary Engines only
 276 kWm standby net power @ 1800 rpm

| Speed rpm | Type of operation | Typical generator output | | Engine power (Net) | |
|-----------|-------------------|--------------------------|-----|--------------------|-----|
| | | kVA | kWe | kWm | hp |
| 1800 | Prime power | 292 | 234 | 254 | 340 |
| | Standby power | 317 | 254 | 276 | 370 |

| Percent of prime power | Fuel consumption at 1800 rpm g/kWh | Fuel consumption at 1800 rpm l/hr |
|------------------------|---------------------------------------|--------------------------------------|
| Standby power | 209 | 74 |
| Prime power | 210 | 69 |
| 75% | 222 | 59 |
| 50% | 239 | 42 |