

Triplex Well Stimulation Pump

WS273XD

- 2700 bhp (2014 bkW) Input Power



Image shown may not reflect actual pump configuration

Specifications

Maximum Input	2700 bhp (2014 bkW)
Maximum rpm	275
Number of Plungers	3
Stroke Length	10 in (254 mm)
Maximum Rod Load	275,000 lb (124 738 kg)
Pump Weight	16,500 lb (7485 kg)
Gear Ratio	5.55:1
Bore Centers	13"

Standard Features

Fluid Ends

- Valve-over-valve design simplifies valve, seat, and plunger installation
- Full line of FIG 1502 discharge configurations
- Zoomie cold weather suction manifold
- Grooveless valve stop; grooveless design eliminates stress risers present with a grooved valve stop design
- Plungers with advanced surface technology
- Premium plunger packing
- Polypak seals for more reliable sealing at suction cover and discharge flanges
- Fluid end components designed to maximize interchangeability across our fluid end line and with industry standard fluid ends
- All XD Geometric benefits

Power Ends

- Reverse helical pinion and bull gear design
- Two-piece stay rod design – pretensioned stay rod lowers cyclic loading and fatigue stress
- Nose plate-to-frame design utilizes a dovetail interlocking design
- Forged bull gears – no cast material
- Forged crankshaft

Optional

- PEMS (Pump Electronic Monitoring System)
- Manifold options by Design to Order

WS273XD Triplex Well Stimulation Duty Performance Ratings

Plunger Diameter		Displacement per Revolution		Rate and Pressure at Pump rpm Well Stimulation and Intermittent Application									
				70		116		150		200		275	
in	mm	Gal/Rev.	L/Rev.	bpm	psi	bpm	psi	bpm	psi	bpm	psi	bpm	psi
4	101.6	1.63	6.18	2.71	21885	4.50	21885	5.83	18904	7.76	14178	10.69	10312
4.5	114.3	2.07	7.82	3.45	17290	5.71	17290	7.38	14937	9.83	11203	13.52	8147
5	127.0	2.55	9.65	4.24	14005	7.05	14005	9.10	12099	12.14	9074	16.69	6599
Input Power (bhp)				1600		2400		2700		2700		2700	

Based on 90% ME and 100% VE – Intermittent Service Only.

Pumps with pressures in excess of 15 000 psi require special gauge and discharge flanges.



WS273XD

Triplex Well Stimulation Pump

2700 bhp (2014 bkW) Input Power

Dimensions

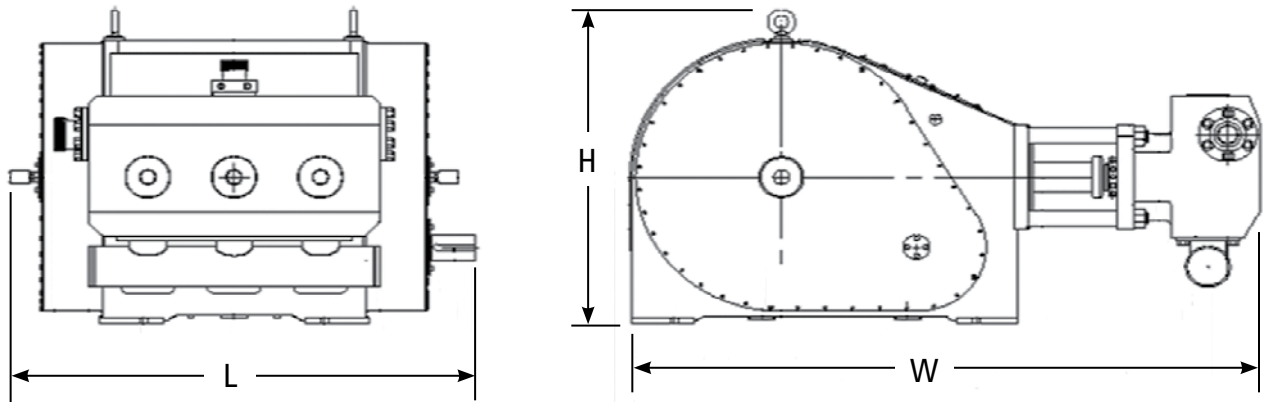

Length	70.1 in (1780.54 mm)
Width	94.8 in (2408.00 mm)
Height	46.8 in (1188.72 mm)
Weight	16,500 lb (7485 kg)

Performance Data

