

# MARINE POWER SOLUTIONS

EDITION 2025



**CATERPILLAR®**

# CONTENTS

	Page
<b>Marine Power Solutions</b> .....	<b>6</b>
<b>We Have What Tomorrow Takes</b> .....	<b>9</b>
<b>Engines and Generator Sets</b>	
Cat® High-Speed and Medium-Speed Solutions .....	11
Cat Propulsion Engines .....	12
Diesel Electric Propulsion (DEP) .....	41
Remanufactured Engines (REMAN) .....	46
Cat Generator Sets and Auxiliary Engines .....	52
Cat Controls and Displays .....	86
Cat Selective Catalytic Reduction (SCR) .....	93
Engine Upgrades .....	96
Customer Value Agreements .....	99
EMD Medium-Speed and Dual Fuel Solutions .....	103
EMD Propulsion and Dual Fuel Engines .....	104
<b>Glossary</b>	
Emissions Standards .....	114
Marine Rating Definition Propulsion Engines .....	118
Marine Rating Definition Generator Sets and Auxiliary Engines .....	121
Abbreviations .....	122
Global Dealer Network .....	123
Caterpillar Marine – Addresses .....	124

*Caterpillar follows a policy of continual product improvement. For this reason, some material and specifications could change without notice.*

# MOVING THE DIAL ON GHG EMISSIONS REDUCTION.\*



The lower greenhouse gas (GHG) fuel landscape is constantly evolving, which means it's more important than ever to be dialed in and ready for what's next. As a leader on the subject, we remain steadfast with research, solutions, innovations and more.

**Because no matter which way the dial turns, at Caterpillar® we have what tomorrow takes.**

\*These fuels reduce lifecycle GHG emissions in the fuel value chain; GHG emissions at the tailpipe are essentially the same as with traditional fuels.

# CAT® C2.2B RETHINK POWER



## C2.2B MARINE GENERATOR SET

16.5 ekw - 22 ekw @1500 rpm

19.8 ekw - 27.5 ekw @1800 rpm



# MARINE POWER SOLUTIONS

## Innovating Cat® Marine Products and Services

### Helping You Navigate the Evolving Energy Landscape.

Cat Marine products are known for their high quality, performance, and reliability. There is an increasing need for lower GHG fuel solutions and power sources that minimize fuel usage, decrease your vessel's environmental impact and lower total cost of ownership.

As a result, Caterpillar is focused on innovating methanol-powered solutions and electric and hybrid systems for reducing lifecycle greenhouse gas (GHG) emissions<sup>1</sup>. Plus, state-of-the-art supervisory controls will integrate system components for efficient performance and the simplicity of plug-and-play.

**All from one source: Caterpillar Marine.**

Caterpillar Marine offers diesel solutions and is developing options like methanol, electric and hybrid to support our customers' evolving energy landscape.



## Delivering Services that Extend the Value

We've also developed leading-edge service solutions to wrap around our products, complemented by a suite of digital tools that deliver actionable insights about engine health and performance.

Customer Value Agreements (CVAs), re-power solutions, emissions upgrade kits and other offerings help improve availability and uptime, reduce criteria emissions, lower cost and simplify ownership so you can focus on your business.

### Cat Marine Power Outputs

Main propulsion: 209 bkW (284 bhp)–6,000 bkW (8,158 bhp)

Generator sets: 10 ekW (10 kVA)–5,200 ekW (6,500 kVA)

## Working Together – Caterpillar and Cat Dealers on the Journey

Our teams remain committed to providing the level of performance and premium support you've come to expect from Caterpillar Marine. Wherever your vessel is constructed or operates, and whether it's powered by traditional or alternative fuel sources, expertly skilled Cat dealers are there for you. With over 500 service locations from shore to shore, you can rely on extensive engine expertise, parts availability and at-the-dock efficiency wherever you are. All established during almost 90 years of Cat marine engines on the water.



**Reach out to your local Cat dealer to learn more about today's power solutions, as well as our strategy to support carbon reduction efforts in the marine industry.**

<sup>1</sup> GHG at the tailpipe are comparable to those produced by conventional fuels.



# FOR THE LONG HAUL.

> CATERPILLAR HAS THE FLEXIBILITY YOU NEED.



## We Have What Tomorrow Takes

### Innovating and integrating. Driven to help you achieve operational success.

At Caterpillar, we've been helping our customers solve big problems for nearly a century – innovating, integrating and tailoring solutions that help build a better, more sustainable world. Your needs are especially important. Whether you're striving to reduce GHG emissions and fuel costs, increase fuel flexibility, move toward electrification or operate more efficiently and safely, you can count on us to help you achieve your sustainability goals.

Here are three examples of how we're putting our experience to work to address greenhouse gas emissions challenges on the water.

#### Reduce your GHG emissions today



- Biofuels deliver similarly rated power output compared to diesel, transient response, start-up time and NOx emissions.
- Biofuels provide CO2e intensity reduction.\*
- Biofuels do not impact standard equipment warranty or emissions certifications.\*\*
- Significantly lower visible exhaust smoke (with HVO), helping reduce environmental impact.\*\*\*
- Emissions upgrade solutions for existing fleets.

#### Fuel flexibility with efficiency and reliability



##### *Current emissions regulations and future standards*

- Biodiesel (FAME) and Renewable Diesel (HVO) are popular solutions to reduce the lifecycle GHG emissions\* of marine operations today using existing Cat engines.
- For methanol engines, Caterpillar Marine's design approach is to meet regulated emissions in both diesel-only mode as well as dual-fuel mode. Engineers are working toward the largest energy substitution of methanol while meeting emission standards. The larger the percentage of methanol that can be used in place of diesel will provide the maximum potential to reduce greenhouse gas emissions.

\*CO2e reduction varies depending on feedstock and blend level. Tailpipe emissions are essentially the same as traditional fuels. (Source: California Air Resource Board, May 2021)

\*\*When using biofuels that meet recommended specifications.

\*\*\*GHG emissions at the tailpipe are essentially the same as with traditional fuels.

# Cat® High-Speed and Medium-Speed Solutions



## Providing hybrid flexibility that integrates conventional and hybrid propulsion systems

### *Integrated power systems*

- Hybrid solutions integrate engines, generator sets and energy storage.
- Intelligent controls enable seamless use of onboard power sources.
- Scalable options to support a wide range of propulsion and power generation applications.

Let's work together to help you to achieve your climate-related objectives. Contact us to start a deeper conversation about the challenges you're facing and the Caterpillar solutions – existing and in development – that can help you address them.

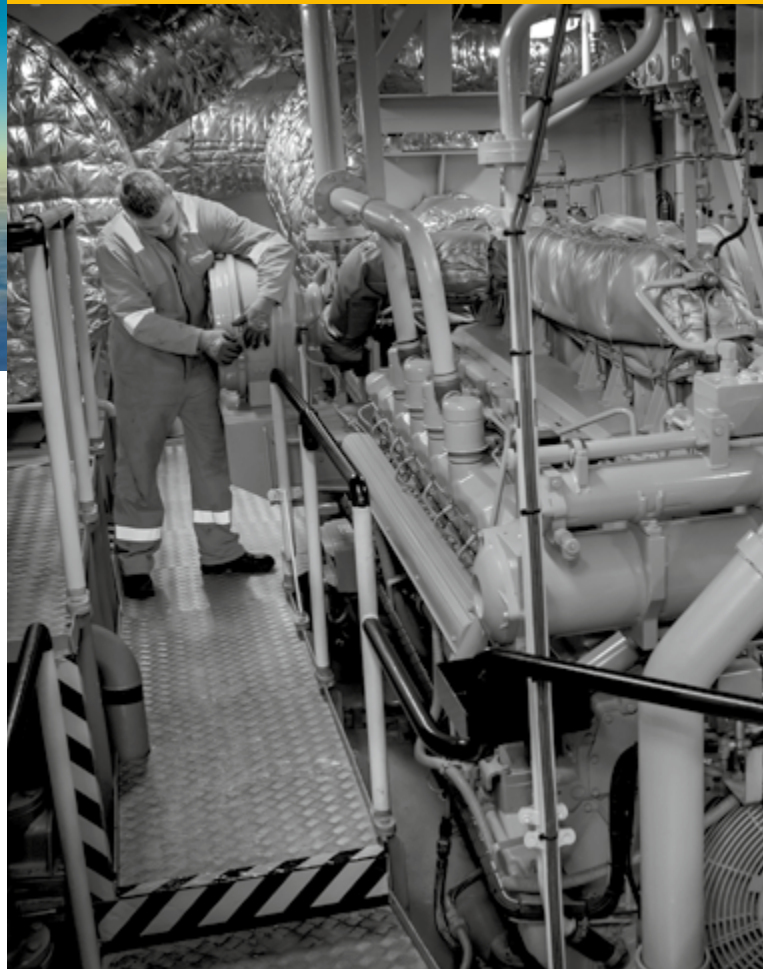

Caterpillar Marine offers a complete range of conventional and electric propulsion solutions spanning across commercial and leisure applications. With power ranging from 209 bkW (284 bhp) to 6,500 bkW (8,834 bhp), there are Cat high-speed and medium-speed propulsion solutions for you.

Whatever the application, and whatever the solution, our products are renowned for not only reliability, durability and efficiency, but also for design and manufacturing innovation. They deliver the advanced control that vessel operators need to maximize power and efficiency, and the enhanced monitoring that ensures peace of mind.

We're built to keep you working – or having fun – on the water.

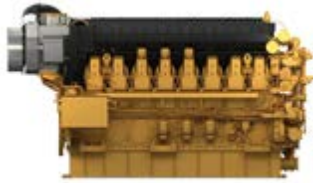

### RATINGS AND FUEL CONSUMPTION

	mhp	bhp	bkW	rpm	U.S. g/h	g/bkWh	IMO	U.S. EPA	EU	China
<b>B</b>	284	280	209	2300	14.9	215.1	II	T3C	RCD	C-II
<b>C</b>	355	350	261	2500	18.3	211.5	II	T3C	RCD	C-II
<b>D</b>	406	400	298	2600	20.3	206.1	II	T3C	RCD	C-II
<b>D</b>	431	425	317	2700	22.9	215.6	II	T3C	RCD	C-II

[Click here for more information](#)

### SPECIFICATIONS

In-line 6, 4-Stroke-Cycle Diesel		
<b>Aspiration</b>	TA	
<b>Bore x Stroke</b>	4.13 x 5.31 in	105 x 135 mm
<b>Displacement</b>	428 in <sup>3</sup>	7.01 liter
<b>Rotation (from flywheel end)</b>	Counterclockwise	
<b>Engine dry weight (approx)</b>	1676 lb	760 kg

### DIMENSIONS

	L	H	W
<b>min.</b>	43.1 in/1095 mm	34.5 in/876 mm	31.4 in/798 mm
<b>max.</b>	43.1 in/1095 mm	34.5 in/876 mm	31.4 in/798 mm

# C7.1

## PROPULSION ENGINE (High Performance Applications)

Electronic Control System

### RATINGS AND FUEL CONSUMPTION

	mhp	bhp	bkW	rpm	U.S. g/h	g/bkWh	IMO	U.S. EPA	EU	China
<b>E</b>	406	400	298	2900	21.8	220.5	II	T3R	RCD	C-II
<b>E</b>	456	450	336	2900	24.4	219.9	II	T3R	RCD	C-II
<b>E</b>	507	500	373	2900	27.3	221.0	II	T3R	RCD	C-II

[Click here for more information](#)

### SPECIFICATIONS

In-line 6, 4-Stroke-Cycle Diesel		
<b>Aspiration</b>	TA	
<b>Bore x Stroke</b>	4.13 x 5.31 in	105 x 135 mm
<b>Displacement</b>	428 in <sup>3</sup>	7.01 liter
<b>Rotation (from flywheel end)</b>	Counterclockwise	
<b>Engine dry weight (approx)</b>	1676 lb	760 kg

### DIMENSIONS

	L	H	W
<b>min.</b>	43.1 in/1095 mm	34.5 in/876 mm	31.4 in/798 mm
<b>max.</b>	43.1 in/1095 mm	34.5 in/876 mm	31.4 in/798 mm

# C9.3

## PROPULSION ENGINE

Electronic Control System

### RATINGS AND FUEL CONSUMPTION

	mhp	bhp	bkW	rpm	U.S. g/h	g/bkWh	IMO	U.S. EPA	EU	China
<b>B</b>	381	375	280	1800	18.7	214.9	II	NC	RCD	NC
<b>C</b>	421	416	310	2100	21.2	216.2	II	NC	RCD	NC
<b>D</b>	483	476	355	2300	24.1	218.1	II	NC	NC	NC

[Click here for more information](#)

### SPECIFICATIONS

In-line 6, 4-Stroke-Cycle Diesel		
<b>Aspiration</b>	TA	
<b>Bore x Stroke</b>	4.53 x 5.87 in	115 x 149 mm
<b>Displacement</b>	568 in <sup>3</sup>	9.3 liter
<b>Rotation (from flywheel end)</b>	Counterclockwise	
<b>Engine dry weight (approx)</b>	2083 - 2474 lb	945 - 1122 kg

### DIMENSIONS

	L	H	W
<b>min.</b>	57.2 in/1452 mm	43.0 in/1093 mm	38.5 in/978 mm
<b>max.</b>	57.2 in/1452 mm	43.0 in/1093 mm	38.5 in/978 mm

### RATINGS AND FUEL CONSUMPTION

	mhp	bhp	bkW	rpm	U.S. g/h	g/bkWh	IMO	U.S. EPA	EU	China
<b>A</b>	345	340	254	1800	16.1	204.4	II	NC	NC	NC
<b>B</b>	390	385	287	1800	18.0	201.9	II	NC	NC	NC
<b>C</b>	460	454	339	2100	21.3	202.2	II	NC	NC	NC
<b>C</b>	497	490	366	2300	23.3	205	II	T3C	RCD	NC
<b>D</b>	578	570	425	2300	27.1	204.9	NC	NC	NC	NC
<b>E</b>	609	600	448	2300	28.4	204	NC	NC	NC	NC
<b>E</b>	669	660	492	2300	33.0	215.6	II	NC	NC	NC
<b>E</b>	715	705	526	2300	35.0	214	II	T3C	RCD	NC

[Click here for more information about Commercial Propulsion Engines](#)

[Click here for more information about High Performance Propulsion Engines](#)

### SPECIFICATIONS

In-line 6, 4-Stroke-Cycle Diesel		
<b>Aspiration</b>	TA	
<b>Bore x Stroke</b>	5.1 x 5.9 in	130 x 150 mm
<b>Displacement</b>	732 in <sup>3</sup>	12 liter
<b>Rotation (from flywheel end)</b>	Counterclockwise	
<b>Engine dry weight (approx)</b>	2588 lb	1174 kg

### DIMENSIONS

	L	H	W
<b>min.</b>	62.0 in/1574 mm	39.5 in/1005 mm	38.1 in/969 mm
<b>max.</b>	62.0 in/1574 mm	39.5 in/1005 mm	38.1 in/969 mm

### RATINGS AND FUEL CONSUMPTION

	mhp	bhp	bkW	rpm	U.S. g/h	g/bkWh	IMO	U.S. EPA	EU	China
<b>A</b>	370	365	272	1800	17.2	203.2	NC	NC	NC	NC
<b>B</b>	406	400	298	1800	18.9	204.0	NC	NC	NC	NC

[Click here for more information](#)

### SPECIFICATIONS

In-line 6, 4-Stroke-Cycle Diesel		
<b>Aspiration</b>	TA	
<b>Bore x Stroke</b>	5.4 x 6.5 in	137.2 x 165.1 mm
<b>Displacement</b>	891 in <sup>3</sup>	14.6 liter
<b>Rotation (from flywheel end)</b>	Counterclockwise	
<b>Engine dry weight (approx)</b>	2921 lb	1325 kg

### DIMENSIONS

	L	H	W
<b>min.</b>	57.3 in/1454.2 mm	50.3 in/1278.5 mm	36.0 in/913.5 mm
<b>max.</b>	57.3 in/1454.2 mm	50.3 in/1278.5 mm	36.0 in/913.5 mm

### RATINGS AND FUEL CONSUMPTION

#### IMO II

	mhp	bhp	bkW	rpm	U.S. g/h	g/bkWh	IMO	U.S. EPA	EU	China
<b>A</b>	460	454	339	1800	21.9	208	II	NC	NC	NC
<b>A</b>	485	479	357	1800	23.0	207.3	II	NC	NC	NC
<b>A</b>	608	600	447	1800	29.1	209.1	II	NC	NC	NC
<b>B</b>	560	553	412	2100	27.8	217.1	II	NC	NC	NC
<b>B</b>	680	670	500	2100	34.1	219.6	II	NC	NC	NC
<b>C</b>	725	715	533	2100	36.4	219.6	II	NC	NC	NC
<b>D</b> <sup>2</sup>	885	873	651	2200	43.7	216	II	NC	NC	NC

[Click here for more information](#)

#### IMO II and U.S. EPA Tier 3

	mhp	bhp	bkW	rpm	U.S. g/h	g/bkWh	IMO	U.S. EPA	EU	China
<b>A</b>	475	469	350	1800	23.1	212.3	II	T3C	RCD	C-II
<b>A</b>	608	600	447	1800	29.2	210.2	II	T3C	RCD	C-II
<b>B</b> <sup>1</sup>	680	670	500	1800-2100	33.6	216.1	II	T3C	RCD	C-II
<b>C</b> <sup>1</sup>	725	715	533	1800-2100	36.0	217.5	II	T3C	RCD	C-II
<b>D</b>	784	775	577	2100	40.0	223.0	NC	T3C	NC	NC
<b>D</b>	814	803	599	2100	41.1	220.8	II	NC	RCD	C-II

<sup>1</sup> Wide Operating Speed Range (WOSR)

Heat Exchanger (32 °C Sea Water Temp), Keel Cooled (52 °C SCAC Temp)

<sup>2</sup> Sea Water Aftercooled

[Click here for more information](#)

(continued)

(continued)

#### EU Stage V

	mhp	bhp	bkW	rpm	U.S. g/h	g/bkWh	IMO	U.S. EPA	EU	China
<b>A</b>	591	583	435	1800	29.0	214.5	NC	NC	EUV	NC
<b>B</b> <sup>1</sup>	680	670	500	1800-2100	34.1	219.7	NC	NC	EUV	NC
<b>D</b>	814	803	599	2100	40.8	223.3	NC	NC	EUV	NC

<sup>1</sup> Wide Operating Speed Range (WOSR)

Heat Exchanger (32 °C Sea Water Temp), Keel Cooled (52 °C SCAC Temp)

Sea Water Aftercooled

[Click here for more information](#)

### SPECIFICATIONS

In-line 6, 4-Stroke-Cycle Diesel		
<b>Aspiration</b>	TA, TTA	
<b>Bore x Stroke</b>	5.7 x 7.2 in	145 x 183 mm
<b>Displacement</b>	1106 in <sup>3</sup>	18.1 liter
<b>Rotation (from flywheel end)</b>	Counterclockwise	
<b>Engine dry weight (approx)</b>	4000 - 4299 lb	1814 - 1950 kg

### DIMENSIONS

	L	H	W
<b>min.</b>	73.0 in/1854 mm	47.2 in/1198 mm	44.6 in/1134 mm
<b>max.</b>	76.0 in/1931 mm	51.2 in/1300 mm	47.4 in/1204 mm

# C18

Electronic Control System

PROPULSION ENGINE (High Performance Applications)

## RATINGS AND FUEL CONSUMPTION

IMO II and U.S. EPA Tier 3

	mhp	bhp	bkW	rpm	U.S. g/h	g/bkWh	IMO	U.S. EPA	EU	China
<b>E</b>	1015	1001	747	2300	52.1	224.5	II	T3R	RCD	C-II
<b>E</b>	1150	1136	847	2300	56.5	214.5	II	T3R	RCD	NC

[Click here for more information](#)

## SPECIFICATIONS

In-line 6, 4-Stroke-Cycle Diesel		
<b>Aspiration</b>	TA, TTA	
<b>Bore x Stroke</b>	5.7 x 7.2 in	145 x 183 mm
<b>Displacement</b>	1106 in <sup>3</sup>	18.1 liter
<b>Rotation (from flywheel end)</b>	Counterclockwise	
<b>Engine dry weight (approx)</b>	4000 - 4299 lb	1814 - 1950 kg

## DIMENSIONS

	L	H	W
<b>min.</b>	73.0 in/1854 mm	47.2 in/1198 mm	44.6 in/1134 mm
<b>max.</b>	76.0 in/1931 mm	51.2 in/1300 mm	47.4 in/1204 mm

# C32

Electronic Control System

PROPULSION ENGINE (Commercial Applications)

## RATINGS AND FUEL CONSUMPTION

IMO II/IMO III

	mhp	bhp	bkW	rpm	U.S. g/h	g/bkWh	IMO	U.S. EPA	EU	China
<b>A<sup>1</sup></b>	669	660	492	1600-1800	31.3	204.4	II	NC	NC	NC
<b>A<sup>1</sup></b>	760	750	559	1600-1800	35.1	201.9	II	NC	NC	C-II
<b>A<sup>1</sup></b>	760	750	559	1600-1800	36.3	209.1	II/III	NC	NC	NC
<b>A<sup>1</sup></b>	811	800	597	1600-1800	39.1	210.5	II	NC	NC	C-II
<b>A<sup>1</sup></b>	862	850	634	1600-1800	39.7	201.4	II	NC	NC	C-II
<b>A</b>	964	950	709	1600	43.8	198.8	II	NC	NC	NC
<b>A<sup>1</sup></b>	1014	1000	746	1600-1800	46.6	201.0	II	NC	NC	C-II
<b>A<sup>1</sup></b>	1014	1000	746	1600-1800	48.2	208.1	II/III	NC	NC	NC
<b>B<sup>1</sup></b>	1217	1200	895	1800-2000	57.4	206.5	II	NC	NC	NC
<b>B<sup>1</sup></b>	1217	1200	895	1800-2000	57.4	206.5	II/III	NC	NC	NC
<b>B</b>	1217	1200	895	2100	60.6	218.0	NC	NC	NC	C-II
<b>B</b>	1319	1300	970	2100	62.5	207.2	II	NC	NC	C-II
<b>B</b>	1319	1300	970	2100	62.5	207.2	II/III	NC	NC	NC
<b>C</b>	1319	1300	970	1800	60.5	200.7	II	NC	NC	NC
<b>C</b>	1319	1300	970	1800	60.5	200.7	II/III	NC	NC	NC
<b>C<sup>1</sup></b>	1319	1300	970	1800-2100	65.9	218.5	II	NC	NC	NC
<b>C<sup>1</sup></b>	1470	1450	1081	2000-2300	74.8	222.5	II	NC	NC	C-II
<b>C<sup>1</sup></b>	1470	1450	1081	2000-2300	74.8	222.5	II/III	NC	NC	NC
<b>D<sup>1,2</sup></b>	1622	1600	1193	2000-2300	79.4	214.0	II	NC	NC	NC

<sup>1</sup> Wide Operating Speed Range (WOSR)

Heat Exchanger (32 °C Sea Water Temp), Keel Cooled (52 °C SCAC Temp)

<sup>2</sup> Sea Water Aftercooled

Contact your local dealer for availability.

[Click here for more information](#)

(continued)

(continued)

## RATINGS AND FUEL CONSUMPTION

### IMO II and U.S. EPA Tier 3

	mhp	bhp	bkW	rpm	U.S. g/h	g/bkWh	IMO	U.S. EPA	EU	China
<b>A'</b>	760	750	559	1600-1800	36.3	209.1	II	T3C	NC	C-II

[Click here for more information](#)

### IMO III, U.S. EPA Tier 4 Final and EU Stage V

	mhp	bhp	bkW	rpm	U.S. g/h	g/bkWh	IMO	U.S. EPA	EU	China
<b>A</b>	1014	1000	746	1600-1800	48.0	207.2	III	T4C	EUV	NC
<b>A'</b>	1014	1000	746	1600-1800	48.0	206.9	III	T4C	EUV	NC
<b>B</b>	1217	1200	895	1800-2100	57.9	208.1	III	T4C	EUV	NC
<b>B'</b>	1217	1200	895	1800-2100	57.3	205.8	III	T4C	EUV	NC
<b>C</b>	1319	1300	970	1800-2100	63.3	210.1	III	T4C	EUV	NC
<b>C'</b>	1319	1300	970	1800-2100	62.3	206.6	III	T4C	EUV	NC
<b>C'</b>	1470	1450	1081	2050-2150	71.1	211.5	III	T4C	NC	NC

<sup>1</sup> Wide Operating Speed Range (WOSR)

Heat Exchanger (32 °C Sea Water Temp), Keel Cooled (52 °C SCAC Temp)

Sea Water Aftercooled

(continued)

[Click here for more information](#)

(continued)

## SPECIFICATIONS

V 12, 4-Stroke-Cycle Diesel		
<b>Aspiration</b>	TTA	
<b>Bore x Stroke</b>	5.71 x 6.38 in	145 x 162 mm
<b>Displacement</b>	1659 in <sup>3</sup>	32.1 liter
<b>Rotation (from flywheel end)</b>	Counterclockwise	
<b>Engine dry weight (approx)</b>	6950 - 7160 lb	3152 - 3248 kg

## DIMENSIONS

	L	H	W
<b>min.</b>	83.5 in/2121 mm	60.9 in/1547 mm	60.17 in/1528 mm
<b>max.</b>	89.9 in/2284 mm	62.5 in/1587 mm	60.17 in/1528 mm

## RATINGS AND FUEL CONSUMPTION

IMO II/III and U.S. EPA Tier 3

	mhp	bhp	bkW	rpm	U.S. g/h	g/bkWh	IMO	U.S. EPA	EU	China
<b>D</b>	1622	1600	1193	2300	83.5	225.3	II	T3R	RCD	C-II
<b>D</b>	1622	1600	1193	2300	83.5	225.3	II/III	NC	NC	NC
<b>E</b>	1724	1700	1268	2300	88.2	224.0	II	T3R	RCD	C-II
<b>E</b>	1825	1800	1342	2300	92.3	221.4	II	T3R	RCD	C-II
<b>E</b>	1925	1900	1418	2300	97.7	221.8	II	T3R	RCD	C-II

Contact your local dealer for availability.  
Sea Water Aftercooled

[Click here for more information](#)

## SPECIFICATIONS

V 12, 4-Stroke-Cycle Diesel		
<b>Aspiration</b>	TTA	
<b>Bore x Stroke</b>	5.71 x 6.38 in	145 x 162 mm
<b>Displacement</b>	1959 in <sup>3</sup>	32.1 liter
<b>Rotation (from flywheel end)</b>	Counterclockwise	
<b>Engine dry weight (approx)</b>	6780 lb	3075 kg

## DIMENSIONS

	L	H	W
<b>min.</b>	82.9 in/2106 mm	56.9 in/1445 mm	58.3 in/1482 mm
<b>max.</b>	82.9 in/2106 mm	56.9 in/1445 mm	58.3 in/1482 mm

## RATINGS AND FUEL CONSUMPTION

IMO II/III and U.S. EPA Tier 4

	mhp	bhp	bkW	rpm	U.S. g/h	g/bkWh	IMO	U.S. EPA	EU	China
<b>A'</b>	669	1200	895	1600-1800	58.0	209.4	II/III	T4C	NC	NC
<b>B</b>	760	1300	969	1800	63.0	208.0	II/III	T4C	NC	NC
<b>B'</b>	760	1540	1081	1800-2100	73.0	218.2	II/III	T4C	NC	NC
<b>C</b>	811	1700	1263	2300	78.2*	222.0*	II	NC	NC	NC

<sup>1</sup>Wide Operating Speed Range (WOSR)  
Heat Exchanger (32 °C Sea Water Temp), Keel Cooled (52 °C SCAC Temp)  
All ratings can be configured as an IMO II engine without aftertreatment  
\*Preliminary data  
Contact your local dealer for availability

## SPECIFICATIONS

V 12, 4-Stroke-Cycle Diesel		
<b>Aspiration</b>	TTA	
<b>Bore x Stroke</b>	5.71 x 6.38 in	145 x 162 mm
<b>Displacement</b>	1959 in <sup>3</sup>	32.1 liter
<b>Rotation (from flywheel end)</b>	Counterclockwise	
<b>Engine dry weight (approx)</b>	6950 - 7160 lb	3152 - 3248 kg

## DIMENSIONS

	L	H	W
<b>min.</b>	84 in/2131 mm	65 in/1650 mm	61 in/1550 mm
<b>max.</b>	90 in/2295 mm	70in/1760 mm	61 in/1550 mm

### RATINGS AND FUEL CONSUMPTION

IMO II/III and U.S. EPA Tier 3

	mhp	bhp	bkW	rpm	U.S. g/h	g/bkWh	IMO	U.S. EPA	EU	China
<b>E</b>	2025	2000	1491	2300	105.0	226.4	II	T3R	RCD	C-II

Contact your local dealer for availability.  
Sea Water Aftercooled

[Click here for more information](#)

### SPECIFICATIONS

V 12, 4-Stroke-Cycle Diesel		
<b>Aspiration</b>	TTA	TA
<b>Bore x Stroke</b>	5.71 x 6.38 in	145 x 162 mm
<b>Displacement</b>	1959 in <sup>3</sup>	32.1 liter
<b>Rotation (from flywheel end)</b>	Counterclockwise	Counterclockwise
<b>Engine dry weight (approx)</b>	6934 lb	3145 kg

### DIMENSIONS

	L	H	W
<b>min.</b>	82.9 in/2106 mm	59.9 in/1445 mm	57.8 in/1469 mm
<b>max.</b>	82.9 in/2106 mm	59.9 in/1445 mm	57.8 in/1469 mm

### RATINGS AND FUEL CONSUMPTION

IMO II/III and U.S. EPA Tier 3

	mhp	bhp	bkW	rpm	U.S. g/h	g/bkWh	IMO	U.S. EPA	EU	China
<b>D</b>	1825	1800	1342	2300	93.5	224.5	II/III	T3R	RCD	C-II
<b>D</b>	2025	2000	1491	2300	104.0	223.5	II/III	T3R	RCD	C-II
<b>E</b>	2230	2200	1641	2300	114.0	223.1	II/III	T3R	RCD	C-II
<b>E</b>	2433	2400	1790	2300	123.0	220.5	II/III	T3R	RCD	C-II

Contact your local dealer for availability.  
Sea Water Aftercooled

[Click here for more information](#)

IMO II Only\*

	mhp	bhp	bkW	rpm	U.S. g/h	g/bkWh	IMO	U.S. EPA	EU	China
<b>D</b>	1825	1800	1342	2300	90.0	216.0	II	–	–	–
<b>D</b>	2025	2000	1491	2300	100.0	216.1	II	–	–	–
<b>E</b>	2230	2200	1641	2300	114.0	223.1	II	–	–	–
<b>E</b>	2433	2400	1790	2300	123.0	220.5	II	–	–	–

\*Up to 10% lower fuel consumption at part load & cruising speed vs. EPA Tier 3  
Sea Water Aftercooled

Contact your local dealer for availability

[Click here for more information](#)

### SPECIFICATIONS

V 12, 4-Stroke-Cycle Diesel		
<b>Aspiration</b>	STA	
<b>Bore x Stroke</b>	5.71 x 6.38 in	145 x 162 mm
<b>Displacement</b>	1959 in <sup>3</sup>	32.1 liter
<b>Rotation (from flywheel end)</b>	Counterclockwise	
<b>Engine dry weight (approx)</b>	7736 lb	3509 kg

### DIMENSIONS

	L	H	W
<b>min.</b>	87.8 in/2231 mm	58.1 in/1478 mm	58.0 in/1474 mm
<b>max.</b>	87.8 in/2231 mm	58.1 in/1478 mm	58.0 in/1474 mm

## RATINGS AND FUEL CONSUMPTION

	mhp	bhp	bkW	rpm	U.S. g/h	g/bkWh	IMO	U.S. EPA	EU	China
<b>A</b>	1317	1300	969	1200	62.2	206.6	II	NC	NC	NC
<b>A<sup>1</sup></b>	1521	1500	1119	1200	69.2	199.1	II	NC	NC	NC
<b>A</b>	1298	1281	955	1600	59.4	200.1	II	NC	NC	NC
<b>A</b>	1419	1400	1044	1600	64.5	198.7	II	NC	NC	NC
<b>A<sup>1</sup></b>	1698	1675	1249	1600	77.2	198.7	II	NC	NC	NC
<b>A<sup>1</sup></b>	1835	1810	1350	1600	82.1	195.7	II	NC	NC	NC
<b>A</b>	1521	1500	1119	1800	68.2	196.3	II	NC	NC	NC
<b>B</b>	1419	1400	1044	1200	66.9	206.1	II	NC	NC	NC
<b>B<sup>1</sup></b>	1622	1600	1193	1200	73.7	198.9	II	NC	NC	NC
<b>B</b>	1379	1360	1014	1600	62.7	199.1	II	NC	NC	NC
<b>B</b>	1521	1500	1119	1600	68.8	198.0	II	NC	NC	NC
<b>B<sup>1</sup></b>	1774	1750	1305	1600	79.9	196.9	II	NC	NC	NC
<b>B<sup>1</sup></b>	1937	1911	1425	1600	86.2	194.7	II	NC	NC	NC
<b>B</b>	1596	1575	1174	1800	71.6	196.0	II	NC	NC	NC
<b>B<sup>1</sup></b>	2281	2250	1678	1800	110.6	212.1	II	NC	NC	NC
<b>C</b>	1521	1500	1119	1200	71.7	206.3	II	NC	NC	NC
<b>C<sup>1</sup></b>	1723	1700	1267	1200	78.9	200.1	II	NC	NC	NC
<b>C</b>	1429	1409	1051	1600	64.9	198.6	II	NC	NC	NC
<b>C</b>	1622	1600	1193	1600	73.4	197.8	II	NC	NC	NC
<b>C<sup>1</sup></b>	1875	1850	1379	1600	83.7	195.2	II	NC	NC	NC
<b>C<sup>1</sup></b>	2039	2012	1500	1600	90.7	194.6	II	NC	NC	NC
<b>C</b>	1672	1650	1230	1800	74.9	195.7	II	NC	NC	NC
<b>C<sup>1</sup></b>	2400	2365	1765	1800	115.8	211.1	II	NC	NC	NC
<b>D<sup>1</sup></b>	2587	2551	1903	1800	124.6	210.9	II	NC	NC	NC
<b>A</b>	1835	1810	1350	1600	90.6	204.5	NC	NC	NC	C-II
<b>B</b>	2281	2250	1678	1800	117.0	213.2	NC	NC	NC	C-II
<b>C</b>	1672	1649	1230	1600	78.3	204.8	NC	NC	NC	C-II
<b>C</b>	1672	1649	1230	1800	80.4	210.2	NC	NC	NC	C-II

<sup>1</sup> High displacement engine (HD)

(continued)

[Click here for more information](#)

(continued)

## SPECIFICATIONS

V 12, 4-Stroke-Cycle Diesel		
<b>Aspiration</b>	TTA	
<b>Bore x Stroke</b>	6.69 x 7.48 in	170 x 190 mm
<b>Bore x Stroke<sup>1</sup></b>	6.69 x 8.46 in	170 x 215 mm
<b>Displacement</b>	3161 in <sup>3</sup>	51.8 liter
<b>Displacement<sup>1</sup></b>	3574 in <sup>3</sup>	58.6 liter
<b>Rotation (from flywheel end)</b>	Counterclockwise or Clockwise	
<b>Engine dry weight (approx)</b>	17,866 - 17,981 lb	8104 - 8156 kg

<sup>1</sup> High displacement engine (HD)

## DIMENSIONS

	L	H	W
<b>min.</b>	102.0 in/2590 mm	75.0 in/1904 mm	80.2 in/2037 mm
<b>max.</b>	105.1 in/2669 mm	88.3 in/2242 mm	87.9 in/2232 mm

## RATINGS AND FUEL CONSUMPTION

	mhp	bhp	bkW	rpm	U.S. g/h	g/bkWh	IMO	U.S. EPA	EU	China
<b>A</b>	1360	1341	1000	1600	61.0	196.4	II/III	T4C	NC	NC
<b>A</b>	1523	1502	1120	1600	66.9	192.2	II/III	T4C	NC	NC
<b>A</b>	1724	1700	1268	1600	76.3	193.7	II/III	T4C	NC	NC
<b>A</b>	1835	1810	1350	1600	81.3	193.9	II/III	T4C	NC	NC
<b>A</b>	2027	2000	1491	1600	90.1	194.4	II/III	T4C	NC	NC
<b>A</b>	1523	1502	1120	1800	71.0	204.1	II/III	T4C	NC	NC
<b>A</b>	1598	1576	1175	1800	73.9	202.4	II/III	T4C	NC	NC
<b>A</b>	1672	1649	1230	1800	77.0	201.5	II/III	T4C	NC	NC
<b>A</b>	2281	2250	1678	1800	104.9	201.2	II/III	T4C	NC	NC
<b>B</b>	2141	2112	1575	1600	90.1	194.8	II/III	T4C	NC	NC
<b>B</b>	2408	2375	1771	1800	110.9	201.5	II/III	T4C	NC	NC
<b>C</b>	2243	2213	1650	1600	90.1	195.2	II/III	T4C	NC	NC
<b>C</b>	2585	2550	1901	1800	112.2	200.3	II/III	T4C	NC	NC
<b>A</b>	1360	1341	1000	1600	61.9	199.1	NC	NC	EUV	NC
<b>A</b>	1523	1502	1120	1600	68.6	197.0	NC	NC	EUV	NC
<b>A</b>	1724	1700	1268	1600	77.0	195.5	NC	NC	EUV	NC
<b>B</b>	1835	1810	1350	1600	68.6	195.9	NC	NC	EUV	NC

All high displacement engines (HD).

All listings showing IMO II/III can be configured as an IMO II engine without aftertreatment.

(continued)

[Click here for more information](#)

(continued)

## SPECIFICATIONS

V 12, 4-Stroke-Cycle Diesel		
<b>Aspiration</b>	TTA	
<b>Bore x Stroke</b>	6.69 x 8.46 in	170 x 215 mm
<b>Displacement</b>	3574 in <sup>3</sup>	58.6 liter
<b>Rotation (from flywheel end)</b>	Counterclockwise	
<b>Engine dry weight (approx)</b>	16,508 lb	7488 kg

## DIMENSIONS

	L	H	W
<b>nominal</b>	104 in / 2646 mm	92 in / 2335 mm	82 in / 2081 mm

## RATINGS AND FUEL CONSUMPTION

	mhp	bhp	bkW	rpm	U.S. g/h	g/bkWh	IMO	U.S. EPA	EU	China
<b>A</b>	2029	2001	1492	1600	92.2	198.9	II	NC	NC	NC
<b>A'</b>	2292	2261	1686	1600	104.1	198.6	II	NC	NC	NC
<b>A'</b>	2481	2447	1825	1600	111.2	196.1	II	NC	NC	NC
<b>B</b>	2128	2099	1565	1600	96.3	198.0	II	NC	NC	NC
<b>B'</b>	2408	2375	1771	1600	108.4	196.9	II	NC	NC	NC
<b>B'</b>	2610	2575	1920	1600	116.3	194.9	II	NC	NC	NC
<b>B'</b>	3046	3004	2240	1800	143.6	206.3	II	NC	NC	NC
<b>C</b>	2230	2199	1640	1600	101.0	198.1	II	NC	NC	NC
<b>C'</b>	2534	2500	1864	1600	113.3	195.5	II	NC	NC	NC
<b>C'</b>	2719	2682	2000	1600	121.0	194.7	II	NC	NC	NC
<b>C'</b>	3195	3151	2350	1800	149.9	205.3	II	NC	NC	NC
<b>D'</b>	2855	2816	2100	1600	127.4	195.2	II	NC	NC	NC
<b>D'</b>	3433	3386	2525	1800	159.9	203.7	II	NC	NC	NC
<b>A'</b>	2162	2132	1590	1600	99.8	202.0	NC	NC	NC	C-II
<b>A'</b>	2481	2447	1825	1600	115.1	202.8	NC	NC	NC	C-II
<b>B'</b>	2271	2240	1670	1600	99.8	202.0	NC	NC	NC	C-II
<b>B'</b>	2610	2575	1920	1600	115.1	202.8	NC	NC	NC	C-II
<b>B'</b>	3046	3004	2240	1800	146.0	209.6	NC	NC	NC	C-II
<b>C'</b>	2712	2675	1995	1600	115.1	202.8	NC	NC	NC	C-II
<b>C'</b>	3195	3151	2350	1800	146.0	209.6	NC	NC	NC	C-II

<sup>1</sup> High displacement engine (HD)

(continued)

[Click here for more information](#)

(continued)

## SPECIFICATIONS

V 16, 4-Stroke-Cycle Diesel		
<b>Aspiration</b>	TTA	
<b>Bore x Stroke</b>	6.69 x 7.48 in	170 x 190 mm
<b>Bore x Stroke<sup>1</sup></b>	6.69 x 8.46 in	170 x 215 mm
<b>Displacement</b>	4211 in <sup>3</sup>	69 liter
<b>Displacement<sup>1</sup></b>	4765 in <sup>3</sup>	78 liter
<b>Rotation (from flywheel end)</b>	Counterclockwise or Clockwise	
<b>Engine dry weight (approx)</b>	20,166 - 20,666 lb	9147 - 9374 kg

<sup>1</sup> High displacement engine (HD)

## DIMENSIONS

	L	H	W
<b>min.</b>	143.1 in/3637 mm	77.4 in/1967 mm	80.2 in/2037 mm
<b>max.</b>	148.0 in/3761 mm	84.6 in/2150 mm	84.3 in/2142 mm

# 3516E

## PROPULSION ENGINE

Electronic Control System

# 3516E

## PROPULSION ENGINE (High Performance Applications)

Electronic Control System

### RATINGS AND FUEL CONSUMPTION

	mhp	bhp	bkW	rpm	U.S. g/h	g/bkWh	IMO	U.S. EPA	EU	China
<b>A</b>	2536	2501	1865	1600	114.6	197.7	II/III	T4C	NC	NC
<b>A</b>	2719	2682	2000	1600	122.7	197.4	II/III	T4C	NC	NC
<b>A</b>	3046	3004	2240	1800	140.7	202.2	II/III	T4C	NC	NC
<b>B</b>	2855	2816	2100	1600	128.9	197.6	II/III	T4C	NC	NC
<b>B</b>	3195	3151	2350	1800	146.4	200.4	II/III	T4C	NC	NC
<b>C</b>	2991	2950	2200	1600	135.5	198.1	II/III	T4C	NC	NC
<b>C/D<sup>1</sup></b>	3433	3386	2525	1800	157.0	200.1	II/III	NC	NC	NC
<b>C</b>	3433	3386	2525	1800	157.0	200.1	III	T4C	NC	NC
<b>D</b>	3549	3500	2610	1800	162.3	200.1	III	T4C	NC	NC

All ratings are high displacement.

All ratings, except 2610 bkW, can be configured as an IMO II engine without aftertreatment.

\* IMO II/III switchable 2525 bkW engine must comply with D-Tier rated duty cycle when operated with Aftertreatment not installed or disabled.

[Click here for more information](#)

### SPECIFICATIONS

V 16, 4-Stroke-Cycle Diesel		
<b>Aspiration</b>	TTA	
<b>Bore x Stroke</b>	6.69 x 8.46 in	170 x 215 mm
<b>Displacement</b>	4765 in <sup>3</sup>	78 liter
<b>Rotation (from flywheel end)</b>	Counterclockwise or Clockwise	
<b>Engine dry weight (approx)</b>	22,084 lb	10,017 kg

### DIMENSIONS

	L	H	W
<b>approximate</b>	125 in / 3186 mm	91 in / 2307 mm	88 in / 2230 mm

### RATINGS AND FUEL CONSUMPTION

	mhp	bhp	bkW	rpm	U.S. g/h	g/bkWh	IMO	U.S. EPA	EU	China
<b>C</b>	3195	3151	2350	1800	147.9	202.6	II/III	T4 <sup>1</sup>	NC	NC
<b>D</b>	3549	3500	2610	1800	165.6	204.1	II/III	T4 <sup>1</sup>	NC	NC
<b>D</b>	3807	3755	2800	1800	178.1	204.6	II/III	T4 <sup>1</sup>	NC	NC
<b>D</b>	4079	4023	3000	1800	192.3	206.2	II/III	T4 <sup>1</sup>	NC	NC

<sup>1</sup> Contact factory for T4 availability.

[Click here for more information](#)

### SPECIFICATIONS

V 16, 4-Stroke-Cycle Diesel		
<b>Aspiration</b>	STA	
<b>Bore x Stroke</b>	6.69 x 8.46 in	170 x 215 mm
<b>Displacement</b>	4765 in <sup>3</sup>	78.1 liter
<b>Rotation (from flywheel end)</b>	Counterclockwise or Clockwise	
<b>Engine dry weight (approx)</b>	22,084 - 25,353 lb	10,017 - 11,500 kg

### DIMENSIONS

	L	H	W
<b>approximate</b>	123 in / 3123 mm	89 in / 2263 mm	71 in / 1800 mm

# C280-6

## PROPULSION ENGINE

Electronic Control System

### RATINGS AND FUEL CONSUMPTION

	mhp	bhp	bkW	rpm	U.S. g/h	g/bkWh	IMO	U.S. EPA	EU	China
<b>CS</b>	2352	2320	1730	900	107	198.6	II	NC	NC	NC
<b>CS</b>	2515	2481	1850	1000	116	201.2	II	NC	NC	NC
<b>MC</b>	2583	2548	1900	900	117	197.6	II	NC	NC	NC
<b>MC</b>	2760	2722	2030	1000	126	200.0	II	NC	NC	NC

C280 fuel rate is at full load on the prop curve, BSFC is at full power condition.

[Click here for more information](#)

### SPECIFICATIONS

In-line 6, 4-Stroke-Cycle Diesel		
<b>Aspiration</b>	TA	
<b>Bore x Stroke</b>	11.0 x 11.8 in	280 x 300 mm
<b>Displacement</b>	6773 in <sup>3</sup>	111 liter
<b>Rotation (from flywheel end)</b>	Counterclockwise or Clockwise	
<b>Engine dry weight (approx)</b>	34,496 lb	15,680 kg

### DIMENSIONS

	L	H	W
<b>approximate</b>	134.8 in/3426 mm	115.4 in/2929 mm	70.6 in/1794 mm

# C280-8

## PROPULSION ENGINE

Electronic Control System

### RATINGS AND FUEL CONSUMPTION

#### IMO II

	mhp	bhp	bkW	rpm	U.S. g/h	g/bkWh	IMO	U.S. EPA	EU	China
<b>CS</b>	3127	3084	2300	900	143	199.7	II	NC	NC	NC
<b>CS</b>	3345	3299	2460	1000	154	201.9	II	NC	NC	NC
<b>MC</b>	3440	3393	2530	900	156	199.0	II	NC	NC	NC
<b>MC</b>	3684	3634	2710	1000	170	202.3	II	NC	NC	NC
<b>MC</b>	4078	4023	3000	1000	189	203.2	II	NC	NC	NC

[Click here for more information](#)

#### IMO III and U.S. EPA Tier 4

	mhp	bhp	bkW	rpm	U.S. g/h	g/bkWh	IMO	U.S. EPA	EU	China
<b>CS</b>	3345	3299	2460	1000	148	193.3	III	T4C	NC	NC
<b>MC</b>	3684	3634	2710	1000	163	194.1	III	T4C	NC	NC

C280 fuel rate is at full load on the prop curve, BSFC is at full power condition.

[Click here for more information](#)

### SPECIFICATIONS

In-line 8, 4-Stroke-Cycle Diesel		
<b>Aspiration</b>	TA	
<b>Bore x Stroke</b>	11.0 x 11.8 in	280 x 300 mm
<b>Displacement</b>	9031 in <sup>3</sup>	148 liter
<b>Rotation (from flywheel end)</b>	Counterclockwise or Clockwise	
<b>Engine dry weight (approx)</b>	41,800 lb	19,000 kg

### DIMENSIONS

	L	H	W
<b>approximate</b>	175.7 in/4463 mm	115.3 in/2930 mm	75.4 in/1914 mm

# C280-12

## PROPULSION ENGINE

Electronic Control System

# C280-16

## PROPULSION ENGINE

Electronic Control System

### RATINGS AND FUEL CONSUMPTION

#### IMO II

	mhp	bhp	bkW	rpm	U.S. g/h	g/bkWh	IMO	U.S. EPA	EU	China
<b>CS</b>	4704	4640	3460	900	213	198.6	II	NC	NC	NC
<b>CS</b>	5031	4962	3700	1000	231	201.2	II	NC	NC	NC
<b>MC</b>	5167	5096	3800	900	233	197.6	II	NC	NC	NC
<b>MC</b>	5520	5444	4060	1000	252	200.0	II	NC	NC	NC
<b>MC/FCV</b>	6118	6035	4500	1000	288	205.7	II	NC	NC	NC

[Click here for more information](#)

#### IMO III and U.S. EPA Tier 4

	mhp	bhp	bkW	rpm	U.S. g/h	g/bkWh	IMO	U.S. EPA	EU	China
<b>CS</b>	5031	4962	3700	1000	225	196.0	III	T4C	NC	NC
<b>MC</b>	5520	5444	4060	1000	247	195.5	III	T4C	NC	NC

C280 fuel rate is at full load on the prop curve, BSFC is at full power condition.

[Click here for more information](#)

### SPECIFICATIONS

V 12, 4-Stroke-Cycle Diesel		
<b>Aspiration</b>	TTA	
<b>Bore x Stroke</b>	11.0 x 11.8 in	280 x 300 mm
<b>Displacement</b>	13,546 in <sup>3</sup>	222 liter
<b>Rotation (from flywheel end)</b>	Counterclockwise or Clockwise	
<b>Engine dry weight (approx)</b>	57,276 lb	25,980 kg

### DIMENSIONS

	L	H	W
<b>approximate</b>	162.2 in/4121 mm	132.6 in/3368 mm	78.7 in/1999 mm

### RATINGS AND FUEL CONSUMPTION

#### IMO II

	mhp	bhp	bkW	rpm	U.S. g/h	g/bkWh	IMO	U.S. EPA	EU	China
<b>CS</b>	6255	6169	4600	900	285	199.7	II	NC	NC	NC
<b>CS</b>	6690	6598	4920	1000	308	201.9	II	NC	NC	NC
<b>MC</b>	6879	6785	5060	900	313	199.0	II	NC	NC	NC
<b>MC</b>	7369	7268	5420	1000	341	202.3	II	NC	NC	NC
<b>MC/FCV</b>	7682	7577	5650	1000	359	204.8	II	NC	NC	NC
<b>MC/FCV</b>	8158	8046	6000	1000	379	203.2	II	NC	NC	NC
<b>**</b>	8834	8713	6500	1000	405	200.8	II	NC	NC	NC

[Click here for more information](#)

#### IMO III and U.S. EPA Tier 4

	mhp	bhp	bkW	rpm	U.S. g/h	g/bkWh	IMO	U.S. EPA	EU	China
<b>CS*</b>	6255	6169	4600	900	272	190.3	III	T4C	NC	NC

[Click here for more information](#)

\*4600 bkW IMO III rating available with E2 cycle for CPP applications only.

\*\*Special rating request only. For application with CPP optimized to 85% of rated power. Please consult A&I team for details.

Arrangements are available in rear mounted turbocharger or front mounted turbocharger (FMT) configurations. Contact Caterpillar A&I team for FMT configurations.

FMT configurations require remote mounted (shipped loose) duplex oil filters and heat exchanger for the oil cooler. Plumbing is required. Single circuit cooling system is not available for FMT configurations.

# C280-16

## PROPULSION ENGINE

Electronic Control System

# DEP

## DIESEL ELECTRIC PROPULSION - 50 HZ

(continued)

### SPECIFICATIONS

V 16, 4-Stroke-Cycle Diesel		
<b>Aspiration</b>	TTA	
<b>Bore x Stroke</b>	11.0 x 11.8 in	280 x 300 mm
<b>Displacement</b>	18,062 in <sup>3</sup>	296 liter
<b>Rotation (from flywheel end)</b>	Counterclockwise or Clockwise	
<b>Engine dry weight (approx)</b>	68,343 lb	31,000 kg

### DIMENSIONS

	L	H	W
<b>approximate</b>	188.2 in/4780 mm	132.6 in/3367 mm	78.7 in/1999 mm

### RATINGS AND FUEL CONSUMPTION

	bhp	bkW	rpm	U.S. g/h	g/bkWh	IMO	U.S. EPA	EU	China
<b>C4.4<sup>1</sup></b>	95.3	71.1	1500	5.3	258.6	NST	T3C	EUV	NC
<b>C4.4<sup>1</sup></b>	116.4	86.8	1500	6.2	227.5	NST	T3C	EUV	C-II
<b>C4.4<sup>1</sup></b>	145.6	108.6	1500	7.4	217.9	NST	T3C	EUV	C-II
<b>C7.1</b>	146.5	109.3	1500	7.9	229.6	NST	T3C	EUV	C-II
<b>C7.1</b>	172.9	129	1500	9.2	227.5	NST	T3C	EUV	C-II
<b>C7.1</b>	219.8	164	1500	11.2	216.5	II/III	T3C	NC	C-II
<b>C9.3</b>	292	218	1500	13.5	198.7	II	NC	NC	NC
<b>C9.3</b>	282	210	1500	13.4	204.7	II/III	NC	NC	NC
<b>C9.3</b>	362	270	1500	16.6	198.3	II	NC	NC	NC
<b>C9.3</b>	351	262	1500	16.9	206.9	II/III	NC	NC	NC
<b>C18</b>	404	301	1500	19.2	205.6	II	NC	NC	NC
<b>C18</b>	514	383	1500	24.4	205.0	II	NC	NC	NC
<b>C18<sup>2</sup></b>	514	383	1500	24.9	206.6	II/III	NC	NC	NC
<b>C18</b>	514	383	1500	23.7	198.9	NC	NC	EUV	NC
<b>C18</b>	587	438	1500	28.7	208.2	II	NC	NC	NC
<b>C18</b>	587	438	1500	28.2	204.8	II/III	NC	NC	NC
<b>C18</b>	617	460	1500	28.2	197.3	NC	NC	EUV	NC
<b>C18</b>	660	492	1500	31.3	204.7	II	NC	NC	NC
<b>C18</b>	660	492	1500	31.1	203.8	II/III	NC	NC	NC
<b>C32</b>	791	590	1500	36.7	200.0	II	NC	NC	C-I
<b>C32</b>	923	688	1500	42.6	199.1	II	NC	NC	C-I
<b>C32</b>	1172	874	1500	53.8	198.2	III	NC	NC	NC
<b>C32</b>	1172	874	1500	55.2	203.1	II/III	NC	NC	NC
<b>C32</b>	1172	874	1500	55.4	204.0	NC	NC	EUV	NC

<sup>1</sup> C4.4 electronic.

<sup>2</sup> Only available via DTO. Fuel sulfur restrictions apply.

(continued)

# DEP

DIESEL ELECTRIC PROPULSION - 50 HZ

(continued)

## RATINGS AND FUEL CONSUMPTION

	bhp	bkW	rpm	U.S. g/h	g/bkWh	IMO	U.S. EPA	EU	China
<b>3512C<sup>3</sup></b>	1826	1362	1500	82.0	193.7	II	NC	NC	NC
<b>3512E<sup>3</sup></b>	1694	1263	1500	74.6	190.0	II/III	NC	NC	NC
<b>3516C<sup>3</sup></b>	2303	1717	1500	106.8	200.0	II	NC	NC	NC
<b>3516C<sup>3</sup></b>	2602	1940	1500	118.7	196.9	II	NC	NC	NC
<b>3516E<sup>3</sup></b>	2303	1717	1500	103.3	193.7	II/III	NC	NC	NC
<b>3516E<sup>3</sup></b>	2602	1940	1500	116.3	193.2	II/III	NC	NC	NC
<b>C280-6</b>	2481	1850	1000	116	201.2	II	NC	NC	NC
<b>C280-6</b>	2722	2030	1000	126	200.0	II	NC	NC	NC
<b>C280-8</b>	3299	2460	1000	153	200.1	II	NC	NC	NC
<b>C280-8</b>	3634	2710	1000	168	199.8	II	NC	NC	NC
<b>C280-12</b>	4962	3700	1000	231	201.2	II	NC	NC	NC
<b>C280-12</b>	5445	4060	1000	252	200.0	II	NC	NC	NC
<b>C280-16</b>	6598	4920	1000	306	200.1	II	NC	NC	NC
<b>C280-16</b>	7268	5420	1000	336	199.8	II	NC	NC	NC

C280 fuel rate at rated power, BSFC is at full power condition.

<sup>3</sup>High displacement engine (HD)

# DEP

DIESEL ELECTRIC PROPULSION - 60 HZ

## RATINGS AND FUEL CONSUMPTION

	bhp	bkW	rpm	U.S. g/h	g/bkWh	IMO	U.S. EPA	EU	China
<b>C4.4<sup>1</sup></b>	95.3	71.1	1800	5.5	247.1	NST	T3C	EUV	NC
<b>C4.4<sup>1</sup></b>	109.2	81.5	1800	5.9	222.8	NST	T3C	EUV	C-II
<b>C4.4<sup>1</sup></b>	145.6	108.6	1800	7.5	217.5	NST	T3C	EUV	C-II
<b>C4.4<sup>1</sup></b>	172.9	129	1800	8.3	211.0	NST	T3C	EUV	C-II
<b>C7.1</b>	172.9	129	1800	9.5	221.2	NST	T3C	EUV	C-II
<b>C7.1</b>	219.7	163.9	1800	11.3	212.6	II/III	T3C	NC	C-II
<b>C7.1</b>	256.4	191.3	1800	13.2	208.6	II/III	T3C	NC	C-II
<b>C7.1</b>	293.0	218.6	1800	14.9	207.1	II/III	T3C	NC	C-II
<b>C9.3</b>	369	275	1800	18.0	211.0	II	T3C	NC	C-II
<b>C9.3</b>	363	271	1800	17.9	212.7	II/III	NC	NC	NC
<b>C9.3</b>	436	325	1800	21.1	208.7	II	T3C	NC	C-II
<b>C18</b>	499	372	1800	24.6	212.5	II	NC	NC	C-I
<b>C18</b>	624	465	1800	30.5	211.0	II	NC	NC	NC
<b>C18</b>	624	465	1800	31.2	216.0	II	T3C	NC	C-II
<b>C18</b>	624	465	1800	31.1	215.1	NC	NC	EUV	NC
<b>C18</b>	803	599	1800	39.1	209.9	II	NC	NC	NC
<b>C18</b>	803	599	1800	39.9	214.1	II/III	NC	NC	C-II
<b>C18</b>	803	599	1800	39.2	210.6	NC	NC	EUV	NC
<b>C32</b>	916	683	1800	43.9	206.8	II	NC	NC	C-I
<b>C32</b>	1047	781	1800	50.1	206.4	II	NC	NC	C-I
<b>C32</b>	1047	781	1800	52.6	216.6	II/III	NC	NC	NC
<b>C32</b>	1333	994	1800	62.8	203.3	II/III	NC	NC	C-I
<b>C32</b>	1333	994	1800	62.0	200.5	III	T4C	NC	NC
<b>C32</b>	1333	994	1800	63.8	206.5	NC	NC	EUV	NC

<sup>1</sup>C4.4 electronic

<sup>2</sup>High displacement engine (HD)

(continued)

(continued)

### RATINGS AND FUEL CONSUMPTION

	bhp	bkW	rpm	U.S. g/h	g/bkWh	IMO	U.S. EPA	EU	China
<b>3512C<sup>2</sup></b>	1920	1431	1800	88.9	199.8	II	NC	NC	NC
<b>3512C<sup>2</sup></b>	2186	1630	1800	106.6	210.5	II	NC	NC	NC
<b>3512C<sup>2</sup></b>	2400	1790	1800	115.8	208.1	II	NC	NC	NC
<b>3512E<sup>2</sup></b>	1920	1432	1800	88.7	199.4	II/III	NC	NC	NC
<b>3512E<sup>2</sup></b>	2188	1632	1800	100.7	198.6	II/III	T4C	NC	NC
<b>3512E<sup>2</sup></b>	2400	1789	1800	109.6	197.0	II/III	T4C	NC	NC
<b>3516C<sup>2</sup></b>	2575	1920	1800	118.3	198.2	II	NC	NC	NC
<b>3516C<sup>2</sup></b>	2809	2095	1800	127.7	196.7	II	NC	NC	NC
<b>3516C<sup>2</sup></b>	2984	2225	1800	136.1	196.8	II	NC	NC	NC
<b>3516C<sup>2</sup></b>	3151	2350	1800	143.6	196.5	II	NC	NC	NC
<b>3516E<sup>2</sup></b>	2576	1921	1800	118.3	198.1	II/III	T4C	NC	NC
<b>3516E<sup>2</sup></b>	2823	2105	1800	130.1	198.9	II/III	T4C	NC	NC
<b>3516E<sup>2</sup></b>	3176	2368	1800	146.8	199.4	II/III	T4C	NC	NC
<b>C280-6</b>	2320	1730	900	106	197.7	II	NC	NC	NC
<b>C280-6</b>	2548	1900	900	115	194.4	II	NC	NC	NC
<b>C280-8</b>	3084	2300	900	138	193.2	III	T4C	NC	NC
<b>C280-8</b>	3084	2300	900	139	195.0	II	NC	NC	NC
<b>C280-8</b>	3393	2530	900	149	189.2	III	T4C	NC	NC
<b>C280-8</b>	3393	2530	900	151	192.4	II	NC	NC	NC
<b>C280-12</b>	4640	3460	900	210	195.2	III	T4C	NC	NC
<b>C280-12</b>	4640	3460	900	213	197.7	II	NC	NC	NC
<b>C280-12</b>	5096	3800	900	228	193.4	III	T4C	NC	NC
<b>C280-12</b>	5096	3800	900	229	194.4	II	NC	NC	NC
<b>C280-16</b>	6169	4600	900	269	188.6	III	T4C	NC	NC
<b>C280-16</b>	6169	4600	900	279	195.0	II	NC	NC	NC
<b>C280-16</b>	6786	5060	900	300	190.8	III	T4C	NC	NC
<b>C280-16</b>	6786	5060	900	302	192.4	II	NC	NC	NC

<sup>2</sup> High displacement engine (HD)

C280 fuel rate at rated power, BSFC is at full power condition.

### Variable Speed DEP

	bhp	bkW	rpm	U.S. g/h	g/bkWh	IMO	U.S. EPA	EU	China
<b>3512C</b>	1810	1350	1600	82.1	195.7	NC	NC	NC	C-II
<b>3512C</b>	2250	1678	1800	110.6	212.1	NC	NC	NC	C-II
<b>3512E</b>	2400	1789	1800	112	201.5	II/III	NC	NC	NC
<b>3512E</b>	2400	1789	1800	112	201.5	III	T4C	NC	NC
<b>3516C</b>	2347	1750	1600	107.3	197.3	NC	NC	NC	C-II
<b>3516C</b>	3004	2240	1800	146.3	210.1	NC	NC	NC	C-II
<b>3516E</b>	2576	1921	1800	121.1	202.9	II/III	NC	NC	NC
<b>3516E</b>	2576	1921	1800	121.1	202.9	III	T4C	NC	NC
<b>3516E</b>	3176	2368	1800	147.5	200.4	II/III	NC	NC	NC
<b>3516E</b>	3176	2368	1800	147.5	200.4	III	T4C	NC	NC

All ratings are high displacement.



Cat Reman offers a range of complete engines across commercial and leisure applications. With power ranges from 224 kW - 524 kW (304 mhp - 710 mhp), there are Cat Reman propulsion solutions for you.

Your engine is the heart of your vessel. Keep it running strong — and reduce your costs and increase your uptime with Cat® Reman complete engines. They're expertly salvaged, carefully validated and engineered with the latest critical design elements and upgrades.

### RATINGS AND FUEL CONSUMPTION

	mhp	bhp	kW	rpm	U.S. g/h	g/kWh	IMO	U.S. EPA	EU	China
E	304	300	224	2800	15.8	224.0	–	NC	–	–
E	355	350	261	2800	19.2	233.0	–	NC	–	–

Cat Reman Complete Engine Part Numbers:  
 300 bhp - 20R7565  
 350 bhp - 20R7566

### SPECIFICATIONS

In-line 6, 4-Stroke-Cycle Diesel	
Aspiration	T
Bore x Stroke	105 x 127 mm
Displacement	6.6 liter
Rotation (from flywheel end)	Counterclockwise
Engine dry weight (approx)	681 kg

### DIMENSIONS

L	H	W
65.5 in/1663 mm	33.8 in/860 mm	33.9/816 mm



# 3126

Mechanical Control System

## CAT REMAN MARINE PROPULSION ENGINE

### RATINGS AND FUEL CONSUMPTION

	mhp	bhp	bkW	rpm	U.S. g/h	g/bkWh	IMO	U.S. EPA	EU	China
<b>E</b>	355	350	261	2800	18.0	218.4	IMO I	NC	–	–
<b>E</b>	426	420	313	2800	22.9	231.7	IMO I	NC	–	–

Cat Reman Complete Engine Part Numbers:

350 bhp - 20R7562

420 bhp - 20R7563

420 bhp - 20R7564

### SPECIFICATIONS

In-line 6, 4-Stroke-Cycle Diesel	
<b>Aspiration</b>	T
<b>Bore x Stroke</b>	110 x 127 mm
<b>Displacement</b>	7.2 liter
<b>Rotation (from flywheel end)</b>	Counterclockwise
<b>Engine dry weight (approx)</b>	722 kg

### DIMENSIONS

	L	H	W
<b>approximate</b>	46.6 in/1184 mm	35.6 in/906 mm	36.9 in/937 mm

# 3126B

Electronic Control System

## CAT REMAN MARINE PROPULSION ENGINE

### RATINGS AND FUEL CONSUMPTION

	mhp	bhp	bkW	rpm	U.S. g/h	g/bkWh	IMO	U.S. EPA	EU	China
<b>E</b>	456	450	336	2800	24.8	234.9	IMO I	NC	–	–

Cat Reman Complete Engine Part Number:

450 bhp - 20R3503

### SPECIFICATIONS

In-line 6, 4-Stroke-Cycle Diesel	
<b>Aspiration</b>	T
<b>Bore x Stroke</b>	110 x 127 mm
<b>Displacement</b>	7.2 liter
<b>Rotation (from flywheel end)</b>	Counterclockwise
<b>Engine dry weight (approx)</b>	722 kg

### DIMENSIONS

	L	H	W
<b>approximate</b>	46.6 in/1184 mm	35.6 in/906 mm	36.9 in/937 mm

## RATINGS AND FUEL CONSUMPTION

	mhp	bhp	bkW	rpm	U.S. g/h	g/bkWh	IMO	U.S. EPA	EU	China
<b>E</b>	710	700	522	2300	35.5	218.6	IMO I	NC	–	–

Cat Reman Complete Engine Part Number:  
700 bhp - 20R6567

## SPECIFICATIONS

In-line 6, 4-Stroke-Cycle Diesel	
<b>Aspiration</b>	T
<b>Bore x Stroke</b>	130 x 150 mm
<b>Displacement</b>	12.0 liter
<b>Rotation (from flywheel end)</b>	Counterclockwise
<b>Engine dry weight (approx)</b>	1174 kg

## DIMENSIONS

	L	H	W
<b>approximate</b>	62.0 in/1574 mm	39.5 in/1005 mm	38.1 in/969 mm

## RATINGS AND FUEL CONSUMPTION

	mhp	bhp	bkW	rpm	U.S. g/h	g/bkWh	IMO	U.S. EPA	EU	China
<b>A</b>	370	365	272	1800	17.6	208.1	IMO I	NC	–	–

Cat Reman Complete Engine Part Number:  
365 bhp - 20R6163

## SPECIFICATIONS

In-line 6, 4-Stroke-Cycle Diesel	
<b>Aspiration</b>	T
<b>Bore x Stroke</b>	137 x 165 mm
<b>Displacement</b>	14.6 liter
<b>Rotation (from flywheel end)</b>	Clockwise
<b>Engine dry weight (approx)</b>	1325 kg

## DIMENSIONS

	L	H	W
<b>min.</b>	57.2 in/1454 mm	50.4 in/1279 mm	35.9 in/914 mm
<b>max.</b>	–	–	–

# Cat Generator Sets and Auxiliary Engines

# C1.5 GENERATOR SET

Mechanical Control System

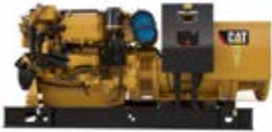

With more than 80 years of marine power experience, we offer a wide array of generator sets spanning from 10 ekW (10 kVA) to 5200 ekW (6500 kVA). Cat marine generator sets and auxiliary engines combine proven design and manufacturing methods with the latest technology, such as advanced control for more power and efficiency, and enhanced monitoring that helps keep you ahead of issues that could potentially affect your uptime.

We're built to provide the power you work with and live by.

## RATINGS AND FUEL CONSUMPTION

Three Phase ekW@.8pf	Single Phase ekW@1.0pf	kVA	Hz	rpm	U.S. g/h	g/bkWh	IMO	U.S. EPA	EU	China
12.0		15.0	60	1800	1.2	269.0	NST	T3C	NST	NC
10.0		12.5	50	1500	1.0	259.4	NST	NC	NST	NC
	12.0	12.0	60	1800	1.2	269.0	NST	T3C	NST	NC
	10.0	10.0	50	1500	1.0	259.4	NST	NC	NST	NC

[Click here for more information](#)

## SPECIFICATIONS

In-line 3, 4-Stroke-Cycle Diesel		
Aspiration	NA	
Bore x Stroke	3.31 x 3.5 in	84 x 90 mm
Displacement	91 in <sup>3</sup>	1.5 liter
Rotation (from flywheel end)	Counterclockwise	
Generator set weight (approx)	703 - 908 lb	319 - 412 kg

## DIMENSIONS

	L	H	W
Open	40.8 in/1038 mm	27.1 in/689 mm	21.1 in/535 mm
Enclosed	43.1 in/1095 mm	27.9 in/711 mm	24.0 in/608 mm

### RATINGS AND FUEL CONSUMPTION

Three Phase kW@.8pf	Single Phase kW@1.0pf	kVA	Hz	rpm	U.S. g/h	g/bkWh	IMO	U.S. EPA	EU	China
18.0		22.5	60	1800	1.63	256.4	NST	T3C	NC	NC
25.0		31.25	60	1800	2.24	239.8	NST	T3C	NC	NC
15.0		18.75	50	1500	1.37	242.6	NST	NC	NC	NC
20.0		25.0	50	1500	1.88	233.0	NST	NC	NC	NC
	18.0	18.0	60	1800	1.63	256.4	NST	T3C	NC	NC
	25.0	25.0	60	1800	2.24	239.8	NST	T3C	NC	NC
	15.0	15.0	50	1500	1.37	242.6	NST	NC	NC	NC
	20.0	20.0	50	1500	1.88	233.0	NST	NC	NC	NC

[Click here for more information](#)

### SPECIFICATIONS

In-line 4, 4-Stroke-Cycle Diesel		
<b>Aspiration</b>	NA, T	
<b>Bore x Stroke</b>	3.31 x 3.94 in	84 x 100 mm
<b>Displacement</b>	135 in <sup>3</sup>	2.2 liter
<b>Rotation (from flywheel end)</b>	Counterclockwise	
<b>Generator set weight (approx)</b>	857/1027 lb	389/466 kg

### DIMENSIONS

	L	H	W
<b>Open</b>	47.9 in/1219 mm	32.8 in/835 mm	22.3 in/567 mm
<b>Enclosed</b>	50.7 in/1290 mm	31.0 in/775 mm	24.7 in/628 mm

### RATINGS AND FUEL CONSUMPTION

PC Rating Single Phase kW@1.0pf *	Single Phase kW@1.0pf	kVA	Hz	rpm	U.S. g/h	g/bkWh	IMO	U.S. EPA	EU	China
19.8	18.0	18.0	60	1800	1.63	256.4	NST	T3C	NC	NC
27.5	25.0	25.0	60	1800	2.24	239.8	NST	T3C	NC	NC
16.5	15.0	15.0	50	1500	1.37	242.6	NST	T3C	NC	NC
22.0	20.0	20.0	50	1500	1.88	233.0	NST	NC	NC	NC

\* PC Rating based on ISO 8528-1 prime power inclusive of +10% capacity. Operating unlimited annual hours with load factor < 50%. No overload is permitted.

### SPECIFICATIONS

In-line 4, 4-Stroke-Cycle Diesel		
<b>Aspiration</b>	NA, T	
<b>Bore x Stroke</b>	3.31 x 3.94 in	84 x 100 mm
<b>Displacement</b>	135 in <sup>3</sup>	2.2 liter
<b>Rotation (from flywheel end)</b>	Counterclockwise	
<b>Generator set weight (approx)</b>	1030 lb	470 kg

### DIMENSIONS

	L	H	W
<b>Enclosed</b>	43.3 in/1100 mm	29.1 in/740 mm	24.7 in/628 mm

### RATINGS AND FUEL CONSUMPTION

ekW@.8pf	kVA	Hz	rpm	U.S. g/h	g/bkWh	IMO	U.S. EPA	EU	China
38.0	47.5	50	1500	2.9	195.1	NST	NC	NC	NC
51.0	64.5	50	1500	3.9	201.5	NST	NC	NC	NC
69.0	86.0	50	1500	4.9	207.7	NST	NC	NC	NC
86.0	107.0	50	1500	6.5	206.1	NST	NC	NC	NC
44.0	55.0	60	1800	3.4	204.1	NST	NC	NC	NC
58.0	73.0	60	1800	4.2	206.3	NST	NC	NC	NC
76.0	95.0	60	1800	5.8	213.3	NST	NC	NC	NC
99.0	123.0	60	1800	7.3	205.2	NST	NC	NC	NC
36.0R	45.0	50	1500	2.9	195.1	NST	NC	NC	NC
49.0R	61.0	50	1500	3.9	201.5	NST	NC	NC	NC
65.0R	81.0	50	1500	4.9	207.7	NST	NC	NC	NC
82.0R	103.0	50	1500	6.5	206.1	NST	NC	NC	NC
42.0R	53.0	60	1800	3.4	204.1	NST	NC	NC	NC
56.0R	70.0	60	1800	4.5	206.3	NST	NC	NC	NC
72.0R	90.0	60	1800	5.8	213.3	NST	NC	NC	NC
95.0R	119.0	60	1800	7.3	205.2	NST	NC	NC	NC

R - Radiator cooled only.

Engine type approval available from ABS, BV, CCS, CRS, DNV, LR, RINA.

(continued)

[Click here for more information](#)

(continued)

### SPECIFICATIONS

In-line 4, 4-Stroke-Cycle Diesel		
<b>Aspiration</b>	NA, T, TA	
<b>Bore x Stroke</b>	4.13 x 5.0 in	105 x 127 mm
<b>Displacement</b>	269 in³	4.4 liter
<b>Rotation (from flywheel end)</b>	Counterclockwise	
<b>Generator set weight (approx)</b>	1664 - 2372 lb	754 - 1076 kg

### DIMENSIONS

	L	H	W
<b>Open min.</b>	56.0 in/1422 mm	39.8 in/1010 mm	27.6 in/700 mm
<b>Open max.</b>	73.3 in/1861 mm	46.2 in/1174 mm	32.3 in/821 mm
<b>Enclosed</b>	68.9 in/1750 mm	47.8 in/1215 mm	39.4 in/1000 mm

### RATINGS AND FUEL CONSUMPTION

#### IMO II and U.S. EPA Tier 3

ekW@.8pf	kVA	Hz	rpm	U.S. g/h	g/bkWh	IMO	U.S. EPA	EU	China
65	81	50	1500	5.3	247.7	NST	T3C	EUV	NC
80	100	50	1500	5.7	221.7	NST	T3C	EUV	C-II
99	124	50	1500	6.8	210.8	NST	T3C	EUV	C-II
65	81	60	1800	5.5	248.0	NST	T3C	EUV	NC
75	94	60	1800	5.3	217.7	NST	T3C	EUV	C-II
99	124	60	1800	6.7	208.9	NST	T3C	EUV	C-II
118	148	60	1800	7.9	206.6	NST	T3C	EUV	C-II
58R	73	50	1500	5.3	247.4	NST	T3C	EUV	NC
73R	91	50	1500	5.7	209.0	NST	T3C	EUV	C-II
88R	110	50	1500	6.8	196.1	NST	T3C	EUV	C-II
56R	64	60	1800	5.5	247.2	NST	T3C	EUV	NC
66R	83	60	1800	5.3	213.3	NST	T3C	EUV	C-II
90R	113	60	1800	6.7	204.9	NST	T3C	EUV	C-II
105R	131	60	1800	7.9	200.8	NST	T3C	EUV	C-II

Engine type approval available from ABS, BV, CCS, DNV, LR, NKK, PR, RINA.

(continued)

[Click here for more information](#)

(continued)

### SPECIFICATIONS

In-line 4, 4-Stroke-Cycle Diesel		
<b>Aspiration</b>	T, TA	
<b>Bore x Stroke</b>	4.13 x 5.0 in	105 x 127 mm
<b>Displacement</b>	269 in³	4.4 liter
<b>Rotation (from flywheel end)</b>	Counterclockwise	
<b>Generator set weight (approx)</b>	2736 - 3389 lb	1241 - 1537 kg

### DIMENSIONS

	L	H	W
<b>min.</b>	66.4 in/1687 mm	49 in/1245 mm	38.3 in/974 mm
<b>max.</b>	80.2 in/2037 mm	78.7 in/1999 mm	38.8 in/986 mm

### RATINGS AND FUEL CONSUMPTION

IMO II and IMO II/III Switchable, U.S. EPA Tier 3

ekW@.8pf	kVA	Hz	rpm	U.S. g/h	g/bkWh	IMO	U.S. EPA	EU	China
100	125	50	1500	7.9	233.7	NST	T3C	EUV	C-II
118	148	50	1500	9.2	224.1	NST	T3C	EUV	C-II
150	188	50	1500	11.2	210.2	II/III	T3C	NC	C-II
118	148	60	1800	9.5	221.5	NST	T3C	EUV	C-II
150	188	60	1800	11.3	212.9	II/III	T3C	NC	C-II
175	219	60	1800	13.2	208.9	II/III	T3C	NC	C-II
200	250	60	1800	14.9	207.3	II/III	T3C	NC	C-II
92R	115	50	1500	7.8	223.7	NST	T3C	EUV	C-II
111R	139	50	1500	9.3	221.8	NST	T3C	EUV	C-II
143R	179	50	1500	11.3	207.5	II/III	T3C	NC	C-II
106R	133	60	1800	9.1	228.7	NST	T3C	EUV	C-II
138R	173	60	1800	11.1	212.8	II/III	T3C	NC	C-II
163R	204	60	1800	12.7	215.9	II/III	T3C	NC	C-II

Engine type approval available from ABS, BV, DNV, LR, NKK, RINA, CRS, CCS.

All ratings subject to IMO can be configured as an IMO II engine without aftertreatment.

[Click here for more information](#)

### SPECIFICATIONS

In-line 6, 4-Stroke-Cycle Diesel		
Aspiration	TA	
Bore x Stroke	4.13 x 5.3 in	105 x 135 mm
Displacement	433.3 in <sup>3</sup>	7.01 liter
Rotation (from flywheel end)	Counterclockwise	
Generator set weight (approx)	3355 - 4718 lb	1522 - 2140 kg

### DIMENSIONS

	L	H	W
min.	76.3 in/1940 mm	49.7 in/1263 mm	37.6 in/956 mm
max.	102 in/2582 mm	62.3 in/1583 mm	39.0 in/993 mm

### RATINGS AND FUEL CONSUMPTION

ekW@.8pf	kVA	Hz	rpm	U.S. g/h	g/bkWh	IMO	U.S. EPA	EU	China
200	250	50	1500	13.2	199.1	II	NC	NC	NC
195	244	50	1500	13.2	204.8	II/III	NC	NC	NC
250	313	50	1500	16.5	198.5	II	NC	NC	NC
245	306	50	1500	16.8	207.0	II/III	NC	NC	NC
250	313	60	1800	17.6	212.3	II	T3C	NC	C-II <sup>2</sup>
250	313	60	1800	17.7	213.4	II/III	NC	NC	NC
300	375	60	1800	20.8	208.9	II	T3C	NC	C-II <sup>2</sup>
185R	231	50	1500	13.2	199.1	II	NC	NC	NC
180R	225	50	1500	13.2	204.8	II/III	NC	NC	NC
235R	294	50	1500	16.5	198.5	II	NC	NC	NC
230R	288	50	1500	16.8	207.0	II/III	NC	NC	NC
224R	280	60	1800	17.6	212.3	II	T3C	NC	NC
224R	280	60	1800	17.7	213.4	II/III	NC	NC	NC
274R	343	60	1800	20.8	208.9	II	T3C	NC	NC

<sup>2</sup> Only available via DTO.

(continued)

[Click here for more information](#)

(continued)

### SPECIFICATIONS

In-line 6, 4-Stroke-Cycle Diesel		
Aspiration	TA	
Bore x Stroke	4.13 x 5.31 in	115 x 149 mm
Displacement	568 in <sup>3</sup>	9.3 liter
Rotation (from flywheel end)	Counterclockwise	
Generator set weight (approx)	5219 lb	2367 kg

### DIMENSIONS

	L	H	W
min.	85.8 in/2179 mm	56.5 in/1436 mm	50.4 in/1260 mm
max.	85.8 in/2179 mm	56.5 in/1436 mm	50.4 in/1260 mm

### RATINGS AND FUEL CONSUMPTION

#### IMO II

ekW@.8pf	kVA	Hz	rpm	U.S. g/h	g/bkWh	IMO	U.S. EPA	EU	China
280	350	50	1500	19.4	205.9	II	NC	NC	NC
360	450	50	1500	24.5	205.4	II	NC	NC	NC
360 <sup>1</sup>	450	50	1500	24.3	203.7	II/III	NC	NC	NC
410	513	50	1500	27.9	204.5	II	NC	NC	NC
410	513	50	1500	27.5	201.9	II/III	NC	NC	NC
465	581	50	1500	31.4	205.4	II	NC	NC	NC
465	581	50	1500	31.2	203.8	II/III	NC	NC	NC
345	431	60	1800	24.7	213.3	II	NC	NC	C-II <sup>2</sup>
430	538	60	1800	30.6	211.3	II	NC	NC	C-II <sup>2</sup>
565	706	60	1800	39.3	210.4	II	NC	NC	C-II <sup>2</sup>
565	706	60	1800	39.9	214.1	II/III	NC	NC	NC
260R	325	50	1500	19.2	205.6	II	NC	NC	NC
335R	419	50	1500	24.4	205.0	II	NC	NC	NC
335R <sup>1</sup>	419	50	1500	24.3	203.7	II/III	NC	NC	NC
390R	486	50	1500	27.9	205.0	II	NC	NC	NC
390R	486	50	1500	27.5	201.9	II/III	NC	NC	NC
445R	556	50	1500	31.3	204.7	II	NC	NC	NC
445R	556	50	1500	31.2	203.8	II/III	NC	NC	NC
310R	388	60	1800	24.7	213.3	II	NC	NC	NC
395R	494	60	1800	30.5	211.0	II	NC	NC	NC
530R	663	60	1800	39.1	209.9	II	NC	NC	NC
530R	663	60	1800	39.9	214.1	II/III	NC	NC	NC

Generator set package includes SRMP generator.

<sup>1</sup> Only available via DTO. Fuel sulfur restrictions apply.

<sup>2</sup> Only available by DTO.

[Click here for more information](#)

(continued)

# C18

## GENERATOR SET

Electronic Control System

# C32

## GENERATOR SET

Electronic Control System

(continued)

### RATINGS AND FUEL CONSUMPTION

IMO II and U.S. EPA Tier 3

ekW@.8pf	kVA	Hz	rpm	U.S. g/h	g/bkWh	IMO	U.S. EPA	EU	China
430	538	60	1800	31.3	214.9	II	T3C	NC	C-II <sup>2</sup>
565	706	60	1800	38.9	206.9	II	NC	NC	C-II <sup>2</sup>
565	706	60	1800	39.9	214.1	II/III	NC	NC	NC
395R	594	60	1800	31.2	216	II	T3C	NC	C-II <sup>2</sup>
530R	663	60	1800	38.9	206.9	II	NC	NC	C-II <sup>2</sup>
530R	663	60	1800	39.9	214.1	II/III	NC	NC	NC

Generator set package includes SRMP generator.

<sup>2</sup> Only available by DTO.

[Click here for more information](#)

### SPECIFICATIONS

In-line 6, 4-Stroke-Cycle Diesel		
<b>Aspiration</b>	TA, TTA	
<b>Bore x Stroke</b>	5.7 x 7.2 in	145 x 183 mm
<b>Displacement</b>	1106 in <sup>3</sup>	18.1 liter
<b>Rotation (from flywheel end)</b>	Counterclockwise	
<b>Generator set weight (approx)</b>	8733 - 9974 lb	3961 - 4524 kg

### DIMENSIONS

	L	H	W
<b>min.</b>	119.7 in/3040 mm	66.3 in/1684 mm	60.9 in/1547 mm
<b>max.</b>	119.7 in/3040 mm	66.3 in/1684 mm	60.9 in/1547 mm

### RATINGS AND FUEL CONSUMPTION

IMO II/IMO III

ekW@.8pf	kVA	Hz	rpm	U.S. g/h	g/bkWh	IMO	U.S. EPA	EU	China
550	688	50	1500	37.2	199.8	II	NC	NC	NC
830	1038	50	1500	55.9	203.1	II	NC	NC	NC
830	1038	50	1500	56.7	206.3	II/III	NC	NC	NC
730	913	60	1800	50.8	206.4	II	NC	NC	C-II
730	913	60	1800	52.6	216.6	II/III	NC	NC	NC
940	1175	60	1800	62.8	203.3	II	NC	NC	C-II
940	1175	60	1800	62.8	203.3	II/III	NC	NC	NC
525R	656	50	1500	37.2	199.8	II	NC	NC	NC
795R	994	50	1500	55.9	203.1	II	NC	NC	NC
795R	994	50	1500	56.7	206.3	II/III	NC	NC	NC
675R	844	60	1800	50.8	206.4	II	NC	NC	C-II
675R	844	60	1800	52.6	216.6	II/III	NC	NC	NC
880R	1100	60	1800	62.8	203.3	II	NC	NC	C-II
880R	1100	60	1800	62.8	203.3	II/III	NC	NC	NC

Heat Exchanger (32 °C Sea Water Temp), Keel Cooled (52 °C SCAC Temp).

Check with your local dealer for availability.

(continued)

[Click here for more information](#)

# C32

## GENERATOR SET

Electronic Control System

# 3500

## CUSTOM GENERATOR SET

Electronic Control System

(continued)

### RATINGS AND FUEL CONSUMPTION

IMO III and U.S. EPA Tier 4 Final

ekW@.8pf	kVA	Hz	rpm	U.S. g/h	g/bkWh	IMO	U.S. EPA	EU	China
830	1038	50	1500	54.1	198.3	III	NC	NC	NC
940	1175	60	1800	61.9	200.4	III	T4C	NC	NC
795R	994	50	1500	54.1	198.3	III	NC	NC	NC
880R	844	60	1800	61.9	200.4	III	T4C	NC	NC

Heat Exchanger (32 °C Sea Water Temp), Keel Cooled (52 °C SCAC Temp)  
Check with your local dealer for availability.

[Click here for more information](#)

### SPECIFICATIONS

V 12, 4-Stroke-Cycle Diesel		
Aspiration	TTA	
Bore x Stroke	5.7 x 6.4 in	145 x 162 mm
Displacement	1959 in <sup>3</sup>	32.1 liter
Rotation (from flywheel end)	Counterclockwise	
Generator set weight (approx)	15,721 lb	7131 kg

### DIMENSIONS

	L	H	W
min.	168.2 in/4271 mm	65.6 in/1667 mm	59.9 in/1521 mm
max.	175.3 in/4452 mm	65.6 in/1667 mm	89.8 in/2280 mm

### RATINGS AND FUEL CONSUMPTION

	ekW @.8pf	Hz	rpm	U.S. g/h	g/bkWh	IMO	U.S. EPA	EU	China
<b>3512C</b>	1360	60	1800	88.9	199.7	II	NC	NC	NC
<b>3512C</b>	1550	60	1800	99.0	195.2	II	NC	NC	NC
<b>3512C</b>	1700	60	1800	108.9	196.4	II	NC	NC	NC
<b>3516C</b>	2250	60	1800	143.6	196.5	II	NC	NC	NC
<b>3512E</b>	1550	60	1800	100.7	197.0	II/III	T4C	NC	NC
<b>3512E</b>	1700	60	1800	109.6	197.0	II/III	T4C	NC	NC
<b>3516E</b>	1825	60	1800	118.3	198.1	II/III	T4C	NC	NC
<b>3516E</b>	2000	60	1800	130.1	198.9	II/III	T4C	NC	NC
<b>3516E</b>	2250	60	1800	146.8	199.4	II/III	T4C	NC	NC
<b>3512E</b>	1200	50	1500	74.6	190.0	II/III	NC	NC	NC
<b>3516E</b>	1630	50	1500	107.0	200.5	II/III	NC	NC	NC
<b>3516E</b>	1840	50	1500	118.7	197.2	II/III	NC	NC	NC

Custom package solutions available via DTO, contact your local dealer for more information.  
ekW is based on a 95% generator efficiency

[Click here for more information](#)

# C280-6

## GENERATOR SET

Electronic Control System

# C280-8

## GENERATOR SET

Electronic Control System

### RATINGS AND FUEL CONSUMPTION

ekW@.8pf	kVA	Hz	rpm	U.S. g/h	g/bkWh	IMO	U.S. EPA	EU	China
1650	2063	60	900	106	197.7	II	NC	NC	NC
1820	2275	60	900	115	194.4	II	NC	NC	NC
1760	2200	50	1000	116	201.2	II	NC	NC	NC
1940	2425	50	1000	126	200.0	II	NC	NC	NC

Custom package solutions available via DTO, contact your local dealer for more information

[Click here for more information](#)

### SPECIFICATIONS

In-line 6, 4-Stroke-Cycle Diesel		
<b>Aspiration</b>	TA	
<b>Bore x Stroke</b>	11.0 x 11.8 in	280 x 300 mm
<b>Displacement</b>	6773 in <sup>3</sup>	111 liter
<b>Rotation (from flywheel end)</b>	Counterclockwise	
<b>Engine dry weight (approx)</b>	34,500 lb	15,680 kg
<b>Generator weight (approx)</b>	18,000 lb	8165 kg

### DIMENSIONS

	L	H	W
<b>approximate</b>	134.8 in/3426 mm	115.4 in/2929 mm	70.6 in/1794 mm

### RATINGS AND FUEL CONSUMPTION

#### IMO II

ekW@.8pf	kVA	Hz	rpm	U.S. g/h	g/bkWh	IMO	U.S. EPA	EU	China
2200	2750	60	900	139	195.0	II	NC	NC	NC
2420	3025	60	900	151	192.4	II	NC	NC	NC
2350	2938	50	1000	153	200.1	II	NC	NC	NC
2600	3250	50	1000	168	199.8	II	NC	NC	NC

[Click here for more information](#)

#### IMO III and U.S. EPA Tier 4

ekW@.8pf	kVA	Hz	rpm	U.S. g/h	g/bkWh	IMO	U.S. EPA	EU	China
2200	2750	60	900	138	193.2	III	T4C	NC	NC
2420	3025	60	900	149	189.2	III	T4C	NC	NC

C280 fuel rate is at full load on the prop curve, BSFC is at full power condition.

[Click here for more information](#)

### SPECIFICATIONS

In-line 8, 4-Stroke-Cycle Diesel		
<b>Aspiration</b>	TA	
<b>Bore x Stroke</b>	11.0 x 11.8 in	280 x 300 mm
<b>Displacement</b>	9031 in <sup>3</sup>	148 liter
<b>Rotation (from flywheel end)</b>	Counterclockwise	
<b>Engine dry weight (approx)</b>	41,800 lb	19,000 kg
<b>Generator weight (approx)</b>	25,000 lb	11,340 kg

### DIMENSIONS

	L	H	W
<b>approximate</b>	175.7 in/4463 mm	115.3 in/2930 mm	75.4 in/1914 mm

# C280-12

## GENERATOR SET

Electronic Control System

# C280-16

## GENERATOR SET

Electronic Control System

### RATINGS AND FUEL CONSUMPTION

#### IMO II

ekW@.8pf	kVA	Hz	rpm	U.S. g/h	g/bkWh	IMO	U.S. EPA	EU	China
3300	4125	60	900	213	197.7	II	NC	NC	NC
3640	4550	60	900	229	194.4	II	NC	NC	NC
3520	4400	50	1000	231	201.2	II	NC	NC	NC
3880	4850	50	1000	252	200.0	II	NC	NC	NC

[Click here for more information](#)

#### IMO III and U.S. EPA Tier 4

ekW@.8pf	kVA	Hz	rpm	U.S. g/h	g/bkWh	IMO	U.S. EPA	EU	China
3300	4125	60	900	210	195.2	III	T4C	NC	NC
3640	4550	60	900	228	193.4	III	T4C	NC	NC

Custom package solutions available via DTO, contact your local dealer for more information

[Click here for more information](#)

### SPECIFICATIONS

V 12, 4-Stroke-Cycle Diesel		
<b>Aspiration</b>	TA	
<b>Bore x Stroke</b>	11.0 x 11.8 in	280 x 300 mm
<b>Displacement</b>	13,546 in <sup>3</sup>	296 liter
<b>Rotation (from flywheel end)</b>	Counterclockwise	
<b>Engine dry weight (approx)</b>	57,276 lb	25,980 kg
<b>Generator weight (approx)</b>	33,000 lb	14,790 kg

### DIMENSIONS

	L	H	W
<b>approximate</b>	162.2 in/4121 mm	132.6 in/3368 mm	78.7 in/1999 mm

### RATINGS AND FUEL CONSUMPTION

#### IMO II

ekW@.8pf	kVA	Hz	rpm	U.S. g/h	g/bkWh	IMO	U.S. EPA	EU	China
4400	5500	60	900	279	195.0	II	NC	NC	NC
4840	6050	60	900	302	192.4	II	NC	NC	NC
4700	5875	50	1000	306	200.1	II	NC	NC	NC
5200	6500	50	1000	336	199.8	II	NC	NC	NC

[Click here for more information](#)

#### IMO III and U.S. EPA Tier 4

ekW@.8pf	kVA	Hz	rpm	U.S. g/h	g/bkWh	IMO	U.S. EPA	EU	China
4400	5500	60	900	269	188.6	III	T4C	NC	NC
4840	6050	60	900	300	190.8	III	T4C	NC	NC

Custom package solutions available via DTO, contact your local dealer for more information

[Click here for more information](#)

### SPECIFICATIONS

V 16, 4-Stroke-Cycle Diesel		
<b>Aspiration</b>	TA	
<b>Bore x Stroke</b>	11.0 x 11.8 in	280 x 300 mm
<b>Displacement</b>	18,062 in <sup>3</sup>	222 liter
<b>Rotation (from flywheel end)</b>	Counterclockwise	
<b>Engine dry weight (approx)</b>	68,343 lb	31,000 kg
<b>Generator weight (approx)</b>	40,000 lb	18,145 kg

### DIMENSIONS

	L	H	W
<b>approximate</b>	188.2 in/4780 mm	132.6 in/3367 mm	78.7 in/1999 mm

# C4.4

## GENERATOR SET ENGINE / AUXILIARY

Electronic Control System

### RATINGS AND FUEL CONSUMPTION

bhp	bkW	rpm	U.S. g/h	g/bkWh	IMO	U.S. EPA	EU	China
95.3	71.1	1500	5.3	247.5	NST	T3C	EUV	NC
116.4	86.8	1500	5.7	225.1	NST	T3C	EUV	C-II
145.6	108.6	1500	6.8	217.0	NST	T3C	EUV	C-II
95.3	71.1	1800	5.5	247.1	NST	T3C	EUV	NC
109.3	81.5	1800	5.3	222.8	NST	T3C	EUV	C-II
145.6	108.6	1800	6.7	217.5	NST	T3C	EUV	C-II
173.0	129.0	1800	7.9	211.0	NST	T3C	EUV	C-II

[Click here for more information](#)

### SPECIFICATIONS

In-line 4, 4-Stroke-Cycle Diesel		
Aspiration	T, TA	
Bore x Stroke	4.13 x 5.0 in	105 x 127 mm
Displacement	269 in <sup>3</sup>	4.4 liter
Rotation (from flywheel end)	Counterclockwise	
Engine dry weight (approx)	1200 - 1278 lb	545 - 580 kg

### DIMENSIONS

	L	H	W
min.	33.7 in/856 mm	40.9 in/1038 mm	30.6 in/778 mm
max.	33.7 in/856 mm	40.9 in/1038 mm	32.0 in/814 mm

# C7.1

## VARIABLE SPEED AUXILIARY ENGINE

Electronic Control System

### RATINGS AND FUEL CONSUMPTION

#### Variable Speed Auxiliary

bhp	bkW	rpm	U.S. g/h	g/bkWh	IMO	U.S. EPA	EU	China
280	208	2300	14.9	215.1	II	T3C	NC	C-II

[Click here for more information](#)

### SPECIFICATIONS

In-line 6, 4-Stroke-Cycle Diesel		
Aspiration	TA	
Bore x Stroke	4.13 x 5.31 in	105 x 135 mm
Displacement	428 in <sup>3</sup>	7.01 liter
Rotation (from flywheel end)	Counterclockwise	
Engine dry weight (approx)	1676 lb	760 kg

### DIMENSIONS

	L	H	W
min.	43.1 in/1095 mm	34.5 in/876 mm	31.4 in/798 mm
max.	43.1 in/1095 mm	34.5 in/876 mm	31.4 in/798 mm

### RATINGS AND FUEL CONSUMPTION

#### Variable Speed Auxiliary

bhp	bkW	rpm	U.S. g/h	g/bkWh	IMO	U.S. EPA	EU	China
249.4	186	2400	14.6	240.0	II	T3C	NC	NC
199.8	149	2400	12.6	256.5	II	T3C	NC	NC
172.9	129	2400	11.3	266.3	II	T3C	EUV	NC

[Click here for more information](#)

#### Constant Speed Auxiliary

bhp	bkW	rpm	U.S. g/h	g/bkWh	IMO	U.S. EPA	EU	China
146.2	109.3	1500	7.9	233.6	NST	T3C	EUV	C-II
172.9	129.0	1500	9.2	224.0	NST	T3C	EUV	C-II
219.9	164.0	1500	11.2	210.0	II	T3C	NC	C-II
172.9	129.0	1800	9.5	221.2	NST	T3C	EUV	C-II
219.9	164.0	1800	11.3	212.6	II	T3C	NC	C-II
256.5	191.3	1800	13.2	208.6	II	T3C	NC	C-II
292.3	218.6	1800	14.9	207.1	II	T3C	NC	C-II

[Click here for more information](#)

(continued)

(continued)

### SPECIFICATIONS

In-line 6, 4-Stroke-Cycle Diesel		
<b>Aspiration</b>	TA	
<b>Bore x Stroke</b>	4.13 x 5.31 in	105 x 135 mm
<b>Displacement</b>	428 in <sup>3</sup>	7.01 liter
<b>Rotation (from flywheel end)</b>	Counterclockwise	
<b>Engine dry weight (approx)</b>	1512 - 1653 lb	686 - 750 kg

### DIMENSIONS

	L	H	W
<b>min.</b>	43.8 in/1112 mm	41.6 in/1056 mm	32.2 in/817 mm
<b>max.</b>	43.8 in/1112 mm	41.6 in/1056 mm	32.6 in/829 mm

### RATINGS AND FUEL CONSUMPTION

#### Constant Speed

bhp	bkW	rpm	U.S. g/h	g/bkWh	IMO	U.S. EPA	EU	China
292	218	1500	13.5	198.7	II	NC	NC	NC
282	210	1500	13.4	204.7	II/III <sup>1</sup>	NC	NC	NC
362	270	1500	16.6	198.3	II	NC	NC	NC
351	262	1500	16.9	206.9	II/III <sup>1</sup>	NC	NC	NC
369	275	1800	18.0	211.0	II	T3C	NC	C-II
363	271	1800	17.9	212.7	II/III <sup>1</sup>	NC	NC	NC
436	325	1800	21.1	208.7	II	T3C	NC	C-II

[Click here for more information](#)

#### Variable Speed Auxiliary

bhp	bkW	rpm	U.S. g/h	g/bkWh	IMO	U.S. EPA	EU	China
375	280	1800	19.3	219.1	II	T3C	NC	C-II

<sup>1</sup> Contact your local dealer for details on availability on IMO III ratings. Power may vary slightly from IMO II rating.

[Click here for more information](#)

### SPECIFICATIONS

In-line 6, 4-Stroke-Cycle Diesel		
<b>Aspiration</b>	TA	
<b>Bore x Stroke</b>	4.53 x 5.87 in	115 x 149 mm
<b>Displacement</b>	568 in <sup>3</sup>	9.3 liter
<b>Rotation (from flywheel end)</b>	Counterclockwise	
<b>Engine dry weight (approx)</b>	2083 - 2474 lb	945 - 1122 kg

### DIMENSIONS

	L	H	W
<b>min.</b>	57.2 in/1452 mm	43.0 in/1093 mm	38.5 in/978 mm
<b>max.</b>	57.2 in/1452 mm	43.0 in/1093 mm	38.5 in/978 mm

### RATINGS AND FUEL CONSUMPTION

#### IMO II/ U.S. EPA Tier 3/ EU Stage V

bhp	bkW	rpm	U.S. g/h	g/bkWh	IMO	U.S. EPA	EU	China
404	301	1500	19.2	205.6	II	NC	NC	NC
514	383	1500	24.4	205.0	II	NC	NC	NC
514 <sup>1</sup>	383	1500	24.1	202.7	II/III	NC	NC	NC
587	438	1500	27.9	205.0	II	NC	NC	NC
587	438	1500	27.5	201.9	II/III	NC	NC	NC
660	492	1500	31.3	204.7	II	NC	NC	NC
660	492	1500	31.1	203.8	II/III	NC	NC	NC
499	372	1800	24.6	212.5	II	NC	NC	NC
624	465	1800	30.5	211.0	II	NC	NC	NC
775	577	1800	37.9	211.1	NC	T3	NC	NC
803	599	1800	39.1	209.9	II	NC	NC	NC
803	599	1800	39.9	214.1	II/III	NC	NC	NC
624	465	1800	31.2	216.0	II	T3C	NC	C-II
803	599	1800	39.1	209.9	II	NC	NC	C-II
803	599	1800	39.9	214.1	II/III	NC	NC	NC
514	383	1500	23.7	198.9	NC	NC	EUV	NC
617	460	1500	28.2	197.3	NC	NC	EUV	NC
624	465	1800	31.1	215.1	NC	NC	EUV	NC
803	599	1800	39.2	210.6	NC	NC	EUV	NC

<sup>1</sup> Only available via DTO. Fuel sulfur restrictions apply.

[Click here for more information](#)

(continued)

# C18

Electronic Control System

## GENERATOR SET ENGINE/AUXILIARY

(continued)

### SPECIFICATIONS

In-line 6, 4-Stroke-Cycle Diesel

<b>Aspiration</b>	TA, TTA	
<b>Bore x Stroke</b>	5.7 x 7.2 in	145 x 183 mm
<b>Displacement</b>	1106 in <sup>3</sup>	
<b>Rotation (from flywheel end)</b>	Counterclockwise	
<b>Generator set weight (approx)</b>	4299 lb	1950 kg

### DIMENSIONS

	L	H	W
<b>min.</b>	73.0 in/1854 mm	51.2 in/1300 mm	44.6 in/1134 mm
<b>max.</b>	73.0 in/1854 mm	51.2 in/1300 mm	44.6 in/1134 mm

# C32

Electronic Control System

## GENERATOR SET ENGINE/AUXILIARY

### RATINGS AND FUEL CONSUMPTION

IMO II/IMO III/U.S. EPA Tier 4

bhp	bkW	rpm	U.S. g/h	g/bkWh	IMO	U.S. EPA	EU	China
791	590	1500	36.7	199.9	II	NC	NC	NC
923	688	1500	42.6	199.1	II	NC	NC	NC
1172	874	1500	55.2	203.1	II	NC	NC	NC
1172	874	1500	55.2	203.1	II/III	NC	NC	NC
916	683	1800	43.9	206.8	II	NC	NC	NC
1047	781	1800	50.1	206.4	II	NC	NC	C-II
1047	781	1800	52.6	216.6	II/III	NC	NC	NC
1333	994	1800	62.8	203.3	II	NC	NC	C-II
1333	994	1800	62.8	203.3	II/III	NC	NC	NC
1172	874	1500	53.9	198.3	III	NC	EUV	NC
1333	994	1800	61.9	200.5	III	T4C	EUV	NC

Contact your local dealer for availability.

[Click here for more information](#)

### SPECIFICATIONS

V 12, 4-Stroke-Cycle Diesel

<b>Aspiration</b>	TTA	
<b>Bore x Stroke</b>	5.7 x 6.4 in	145 x 162 mm
<b>Displacement</b>	1959 in <sup>3</sup>	32.1 liter
<b>Rotation (from flywheel end)</b>	Counterclockwise	
<b>Engine dry weight (approx)</b>	6950 - 7160 lb	3152 - 3248 kg

### DIMENSIONS

	L	H	W
<b>min.</b>	83.5 in/2121 mm	60.9 in/1547 mm	60.2 in/1528 mm
<b>max.</b>	89.9 in/2284 mm	62.5 in/1587 mm	60.2 in/1528 mm

### RATINGS AND FUEL CONSUMPTION

#### IMO II/IMO III/U.S. EPA T4

bhp	bkW	rpm	U.S. g/h	g/bkWh	IMO	U.S. EPA	EU	China
1411	1053	1500	66.5	203.3	II/III	NC	NC	NC
1623	1211	1800	78.0	207.7	II/III	T4C	NC	NC

Contact your local dealer for availability.

All ratings can be configured as an IMO II engine without aftertreatment.

[Click here for more information](#)

### SPECIFICATIONS

#### V 12, 4-Stroke-Cycle Diesel

<b>Aspiration</b>	TTA	
<b>Bore x Stroke</b>	5.7 x 6.4 in	145 x 162 mm
<b>Displacement</b>	1959 in <sup>3</sup>	32.1 liter
<b>Rotation (from flywheel end)</b>	Counterclockwise	
<b>Engine dry weight (approx)</b>	7495 - 8775 lb	3400 - 3980 kg

### DIMENSIONS

	L	H	W
<b>min.</b>	84 in/2133 mm	64 in/1625 mm	61 in/1550 mm
<b>max.</b>	92 in/2336 mm	70 in/1778 mm	61 in/1550 mm

### RATINGS AND FUEL CONSUMPTION

	bhp	bkW	rpm	U.S. g/h	g/bkWh	IMO	U.S. EPA	EU	China
<b>3512C<sup>1</sup></b>	1826	1362	1500	82	193.7	II	NC	NC	NC
<b>3516C<sup>1</sup></b>	2303	1717	1500	106.8	200	II	NC	NC	NC
<b>3516C<sup>1</sup></b>	2602	1940	1500	118.7	196.9	II	NC	NC	NC
<b>3512C</b>	1920	1431	1800	88.9	199.7	II	NC	NC	NC
<b>3512C<sup>1</sup></b>	2183	1628	1800	99	195.2	II	NC	NC	NC
<b>3512C<sup>1</sup></b>	2394	1786	1800	108.9	196.4	II	NC	NC	NC
<b>3516C<sup>1</sup></b>	2575	1920	1800	118.1	197.8	II	NC	NC	NC
<b>3516C<sup>1</sup></b>	2809	2095	1800	127.7	196.7	II	NC	NC	NC
<b>3516C<sup>1</sup></b>	2984	2225	1800	136.1	196.8	II	NC	NC	NC
<b>3516C<sup>1</sup></b>	3151	2350	1800	143.6	196.5	II	NC	NC	NC
<b>3512E<sup>1</sup></b>	1694	1263	1500	74.6	190	II/III	NC	NC	NC
<b>3516E<sup>1</sup></b>	2303	1717	1500	103.3	193.7	II/III	NC	NC	NC
<b>3516E<sup>1</sup></b>	2602	1940	1500	116.3	193.2	II/III	NC	NC	NC
<b>3512E<sup>1</sup></b>	1920	1432	1800	88.7	199.4	II/III	NC	NC	NC
<b>3512E<sup>1</sup></b>	2188	1632	1800	101.9	200.9	II/III	T4	NC	NC
<b>3512E<sup>1</sup></b>	2400	1789	1800	111.7	200.9	II/III	T4	NC	NC
<b>3516E<sup>1</sup></b>	2576	1921	1800	118.3	198.1	II/III	T4	NC	NC
<b>3516E<sup>1</sup></b>	2823	2105	1800	130.1	198.9	II/III	T4	NC	NC
<b>3516E<sup>1</sup></b>	3176	2368	1800	146.8	199.4	II/III	T4	NC	NC
<b>3512C<sup>1</sup></b>	1810	1350	1600	82.1	195.7	NC	NC	NC	C-II
<b>3516C<sup>1</sup></b>	2347	1750	1600	107.3	197.3	NC	NC	NC	C-II
<b>3512C<sup>1</sup></b>	2250	1678	1800	110.6	212.1	NC	NC	NC	C-II
<b>3516C<sup>1</sup></b>	3004	2240	1800	146.3	210.1	NC	NC	NC	C-II

<sup>1</sup> Ratings are high displacement (HD).

[3512E: Click here for more information](#)

[3516E: Click here for more information](#)

(continued)

(continued)

## SPECIFICATIONS

V 12, V 16, 4-Stroke-Cycle Diesel			
<b>Aspiration</b>		TA	
<b>Bore x Stroke</b>		6.7 x 8.5 in	170 x 215 mm
<b>Displacement</b>	<b>3512E</b>	3576 in <sup>3</sup>	58.6 liter
	<b>3516E</b>	4766 in <sup>3</sup>	78.1 liter
<b>Engine dry weight (approx)</b>	<b>3512E</b>	19,103 lb	8665 kg
	<b>3516E</b>	22,408 lb	10,164 kg

## DIMENSIONS

		L	H	W
<b>3512E</b>	<b>min.</b>	127.2 in/3232 mm	86.8 in/2205 mm	85.0 in/2160 mm
	<b>max.</b>	127.2 in/3232 mm	86.8 in/2205 mm	85.0 in/2160 mm
<b>3516E</b>	<b>min.</b>	148.5 in/3773 mm	87.6 in/2224 mm	89.9 in/2284 mm
	<b>max.</b>	148.5 in/3773 mm	87.6 in/2224 mm	89.9 in/2284 mm

## RATINGS AND FUEL CONSUMPTION

	bhp	bkW	rpm	U.S. g/h	g/bkWh	IMO	U.S. EPA	EU	China
<b>C280-6</b>	2320	1730	900	106	197.7	II	NC	NC	NC
<b>C280-6</b>	2481	1850	1000	116	201.2	II	NC	NC	NC
<b>C280-6</b>	2548	1900	900	115	194.4	II	NC	NC	NC
<b>C280-6</b>	2722	2030	1000	126	200.0	II	NC	NC	NC
<b>C280-8</b>	3084	2300	900	138	193.2	III	T4C	NC	NC
<b>C280-8</b>	3084	2300	900	139	195.0	II	NC	NC	NC
<b>C280-8</b>	3299	2460	1000	153	200.1	II	NC	NC	NC
<b>C280-8</b>	3393	2530	900	149	189.2	III	T4C	NC	NC
<b>C280-8</b>	3393	2530	900	151	192.4	II	NC	NC	NC
<b>C280-8</b>	3634	2710	1000	168	199.8	II	NC	NC	NC
<b>C280-12</b>	4640	3460	900	210	195.2	III	T4C	NC	NC
<b>C280-12</b>	4640	3460	900	213	197.7	II	NC	NC	NC
<b>C280-12</b>	4962	3700	1000	231	201.2	II	NC	NC	NC
<b>C280-12</b>	5096	3800	900	228	193.4	III	T4C	NC	NC
<b>C280-12</b>	5096	3800	900	229	194.4	II	NC	NC	NC
<b>C280-12</b>	5444	4060	1000	252	200.0	II	NC	NC	NC
<b>C280-16</b>	6169	4600	900	269	188.6	III	T4C	NC	NC
<b>C280-16</b>	6169	4600	900	249	195.0	II	NC	NC	NC
<b>C280-16</b>	6598	4920	1000	306	200.1	II	NC	NC	NC
<b>C280-16</b>	6785	5060	900	300	190.8	III	T4C	NC	NC
<b>C280-16</b>	6785	5060	900	302	192.4	II	NC	NC	NC
<b>C280-16</b>	7268	5420	1000	336	199.8	II	NC	NC	NC

C280 fuel rate is at rated power, BSFC is at full power condition.  
 Custom package solutions available via DTO, contact your local dealer  
 for more information.

(continued)

[Click here for more information](#)

# C280 SERIES

AUXILIARY

Electronic Control System

(continued)

## SPECIFICATIONS

In-line 6, In-line 8, V 12, V 16, 4-Stroke-Cycle Diesel

Aspiration		TA	
Bore x Stroke		11.0 x 11.8 in	280 x 300 mm
Displacement	C280-6	6773 in <sup>3</sup>	111 liter
	C280-8	9031 in <sup>3</sup>	148 liter
	C280-12	13,546 in <sup>3</sup>	222 liter
	C280-16	18,062 in <sup>3</sup>	296 liter
Engine dry weight (approx)	C280-6	34,496 lb	15,680 kg
	C280-8	41,800 lb	19,000 kg
	C280-12	57,276 lb	25,980 kg
	C280-16	68,343 lb	31,000 kg

## DIMENSIONS

	L	H	W
C280-6	134.8 in / 3426 mm	115.4 in / 2929 mm	70.6 in / 1794 mm
C280-8	175.7 in / 4463 mm	115.3 in / 2930 mm	75.4 in / 1914 mm
C280-12	162.2 in / 4121 mm	132.6 in / 3368 mm	78.7 in / 1999 mm
C280-16	188.2 in / 4780 mm	132.6 in / 3367 mm	78.7 in / 1999 mm

# TOUGHER THAN EVER.

## FOR GOVERNMENTAL & DEFENSE



Designed for Mission Readiness  
 Outstanding Power Density & Performance  
 Lower Signature  
 Best Servicability



THE NEW  
**C280 SERIES**  
**POWER RANGE: 1.7 - 8 MW**  
 DESTROYER | LPD | FRIGATE | OPV & CORVETTE

# Cat Controls and Displays

## Propulsion Control System

### Cat MPC100 – Propulsion Control System for Conventional Drive Systems

MPC100 is a proven Propulsion Control System solution for both single and twin propeller applications. By providing redundant control capability it is integrating both primary and secondary (back-up) control ability of engine and marine transmission. Built in trolling valve control together with very flexible configuration allows MPC100 to be adopted to each installation as well as customized to high demands of each captain.

- Highly reliable with built in redundancy
- Simplified installation and configuration
- Safety and quality compliance (CE, USCG, ABYC, IACS)
- Supporting both 12 and 24 VDC powered applications
- Highly configurable for multiple powertrain configurations using Cat Electronic Technician (ET)
- Supporting all Cat electronically controlled propulsion engines from Cat C7.1 – C280.
- Compatible with all major marine transmissions
- Up to 8 command stations
- Built in control of the engine, transmission incl. trolling valve
- Mode selector incl. warm up, trolling, advanced trolling, slow vessel and cruising mode with possibility to adapt modes of operation
- Synchronization mode allowing user to operate twin propeller boats using single lever
- Optional back-up control capability
- Configurable shaft brake control
- Engine start interlocks

[Click here for more information](#)



## Propulsion Control System

### Cat MPC300 – Propulsion Control System

MPC300 is a proven Propulsion Control System designed specifically for commercial vessels, super yachts, and governmental applications. Cat® MPC300's main strength lies in its innovative redundancy design, seamlessly integrating backup components for all critical system sections.

- Provides hot standby for innovative redundant design of power supply, control processor and communication channels
- Suitable for commercial and safety-critical applications
- Offers programmable auxiliary I/Os, NMEA 2K and Modbus RTU for ease of integration
- Nicely integrates with modern bridge designs
- Facilitates single and twin-screw propulsion applications, shaft brake control and shaft speed sensor (optional)
- Enables up to 8 remote command stations
- Supports all electronically controlled Cat Marine Propulsion Engines and major marine transmissions
- Configurable shaft brake control

#### Type approved by Marine Class Societies

- Bureau Veritas
- American Bureau of Shipping
- Croatian Register of Shipping
- ABS Quality Evaluations, Inc



[Click here for more information](#)



## Displays

### Cat Marine Displays (CMD)

The Cat Marine Display (CMD) provides the operator with easy-to-read, high resolution graphics to monitor all vessel operations. The modifiable screen offers complete user customization and a visually streamlined experience. All electronics are environmentally sealed for increased durability and safety and are built to perform reliably in extreme conditions.



The CMD is available in 5", 8", or 13" screen sizes. The CMD5, in particular, boasts a more compact design, front and rear waterproof IP66 rating, and a highly appreciated tactile feel for its navigation keys.

New CMD8 and CMD13 Gen II displays offer an appealing design and easy to use touch screen navigations. Additional features include multiple graphic skin options, configurable splash and monitoring screens, embedded manuals, Modbus, and IT camera support.

## Propulsion, Auxiliary Engine and Genset Control Panels

Cat Control Panels provide complete propulsion engine and generator set control and monitoring from local and remote locations, including engine start/stop capability, alarm and protection, user and integration interfaces. System modularity allows expansion of remote monitoring, input/output capabilities and programmable relays.

### Control Panels – Marine Propulsion Engines

#### C7.1 - C32

#### Remote Analogue Panel

For remote monitoring of engine basic parameters (available with C7.1 only).

#### MECP IB

The MECP IB is an affordable, basic control panel that can be mounted directly on the engine. For non MCS approved installations.

#### C9.3-3500 (C280)\*

\* See dealer for availability.

#### MECP II/LECP II

The MECP II/LECP II is MCS type-approved for manned and un-manned engine rooms. It provides local throttle control, a color display, advanced diagnostics, and integration possibilities. This engine control panel is enhanced by built-in connectivity solution allowing easy onboarding and access to variety of Customer Value Agreements (CVAs) offerings.

#### MECP IIIB/LECP III

The MECP IIIB has all the features of the MECP II and has additional I/O, it supports more expansion modules, and has extra space for customer options. This engine control and integration panel is enhanced by built-in connectivity solution allowing easy onboarding and access to variety of CVA offerings.

## Control Panels – Marine Generator Set and Auxiliary Engines

### C4.4 - C7.1

#### MGGP 200

*(for electronically controlled engines only)*

The MGGP 200 is an analogue gauge panel providing basic instrumentation of engine parameters, as well as alarm indication and engine start/stop buttons.

#### MCS3

The MCS3 MCS type-approved (not Cyber-security compliant) panel provides generator and engine monitoring for manned and un-manned engine rooms.

It includes MODbus and CANbus (J1939) interfaces (on electronically controlled engines only), AC monitoring, and optional load-share control for multiple genset installations.

Multi-position and remote mountable options.

### C2.2B

#### MDC100/150

The MDC panel range provides configurable digital controls, which are not MCS type approved, enables comprehensive monitoring of both the engine and generator. It is equipped with customizable I/Os and supports ModBUS RTU/TCP/IP for seamless integration.

The MDC150, in addition to all standard features, offers built-in capabilities for paralleling and load sharing.

### C4.4 - C32

#### EMCP 4.2B

*(for electronically controlled engines only)*

The EMCP 4.2B non MCS type-approved panel provides generator and engine monitoring.

#### MGCP II

The MGCP II is MCS type-approved for manned and un-manned engine rooms. It provides local throttle control, a color display and advanced diagnostics and communications. This generator control and integration panel is enhanced by built in connectivity solution allowing easy onboarding and access to variety of CVA offerings.

### C9.3 - 3500 (C280)\*

*\* See dealer for availability.*

#### MGCP IIIB/LECP III

The MGCP II is MCS type-approved for manned and un-manned engine rooms. It provides local throttle control, a color display and advanced diagnostics and communications. This generator control and integration panel is enhanced by built in connectivity solution allowing easy onboarding and access to variety of CVA offerings.

#### L2

The L2 includes a CMPD as the main operator interface. It includes switches for engine protection override, prelude override, torque limit and manual speed control.

## Accessories

### RTD Module

The RTD Module monitors 8 RTD temperature sensors. The RTD Module is often used on generators.

### Thermocouple Module

The TC Module monitors 20 thermocouple temperature sensors. The TC Module is generally used on an engine.

### Remote Panel 220E (MECP/MGCP II and III only)

The RP 220E can remotely monitor and start/stop two engines or gensets. Multiple RPs can be installed on a ship.

### Remote Panel 410E (MECP/MGCP II and III only)

The RP 410E can remotely monitor and start/stop eight engines or gensets and four IP cameras. Multiple RPs can be installed on a ship.

### Remote I/O 410 Module (MECP/MGCP II and III only)

The RIO 410 provides additional switch and sensor inputs for the control panel, as well as relay outputs. Up to four RIOs can be used with the IIIB panels, one with the II panels.

### Relay Module (MECP/MGCP III only)

The ARM provides 14 programmable relays. It can be connected to the Local Control Panel or to an RP.

### Power Analyzer Module (MGCP II and III only)

The PAM provides generator power information, such as phase voltage, current, power factor, Total Harmonic Distortion (THD), etc.

### MSDU – Emergency Shutdown Module

Basic shutdown unit available as an option with C4.4 and C7.1 electronically controlled engine.

# Cat Selective Catalytic Reduction (SCR)

## A simple technical solution can help you meet today's stringent maritime emission standards.

The easy-to-install Cat SCR System is an exhaust gas aftertreatment solution compliant with U.S. Environmental Protection Agency (EPA) Tier 4 Final and International Maritime Organization (IMO) III emission standards. It is a sustainable solution to reduce NO<sub>x</sub> emissions without sacrificing Caterpillar's marine engine efficiency, as well as maintain the durability and reliability that our customers expect. Regional initiatives from environmentally friendly governments are already in effect with incentives benefitting ship owners who invest in NO<sub>x</sub> emissions reduction technology. Caterpillar has evaluated multiple solutions, and the conclusion has been that SCR is the optimal solution to meet U.S. EPA Tier 4 and IMO III requirements. SCR allows for the lowest total cost of ownership when compared to other solutions, such as EGR.

### Features and Benefits

- Designed for NO<sub>x</sub> emissions reduction. Meets IMO III, U.S. EPA Tier 4, and EU Stage V emission standards
- Compact package and flexible mounting configurations
- A fully integrated and certified solution, all available from the engine OEM
- Available for new vessel construction and retrofit / repower projects
- Easy to install with minimum impact to vessel design
- Common control and monitoring system for reliable and safe operation
- Global dealer network for installation and service in any location

## Clean Emission Module (CEM)

Caterpillar designed the SCR System for Cat marine applications with a compact and easy to install Clean Emission Module (CEM), you will benefit from an optimally matched system with minimum impact to vessel design. Cat offers numerous CEM options with varying configurations and mounting options to suit all markets and vessel types.



Cat C7.1 and C9.3 CEM Airless, IMO II/III switchable



Cat C18 double CEM with Y-Pipe Airless, IMO II/III switchable

Cat C18 CEM Airless, EU Stage V with DPF



Cat C18 and C32 CEM Air-Assist, U.S. EPA Tier 4 and IMO III U-Flow or Z-Flow configured.



U-flow and Z-Flow options are available but not pictured.



Cat 3500 series CEM Air-Assist, U.S. EPA Tier 4, IMO II/III switchable U-Flow or Z-Flow configured



Cat C32/3512 series EU Stage V, DPF



Cat C280 CEM Air-Assist, U.S. EPA Tier 4 and IMO III vertical stack



Examples: Dosing cabinet

**Contact your local dealer for more information.**

*All pictures shown are for illustration purpose only. Product may vary due to product enhancement.*

# Engine Upgrades for Performance & Emission Improvements

Thinking of repowering to improve performance or meet new emission standards? Before you do, consider giving your engine an upgrade. An upgrade can help you achieve the specifications you want, but with less investment than purchasing new. It's a proven interim solution for customers navigating the energy transition, especially since upgrades can be implemented during a scheduled major overhaul so there's no additional downtime.

## Emission Upgrades

Upgrade your engines to current emission regulations and gain the benefits of the newest Caterpillar Marine technology without replacing your engine.

- Emissions Reduction

Get the most out of your vessel with reduced criteria emissions while maximizing the power of your fleet. Our innovative solutions can meet emission standards for different parts of the world while optimizing your engine efficiency.

- Sustainability

Reduce emissions while meeting EPA and IMO emission standards. Emissions upgrades are available for select engine ratings.

Emission Upgrades are currently available for select Cat® 3500, 3600 and C280 engines. Upgrade to the Latest Emissions Technology available for your engine. Download upgrade options here - [CM20240823-89146-ac428](https://www.caterpillar.com/CM20240823-89146-ac428) (scene7.com)

## Performance Upgrades

Optimize engine response time and fuel efficiency, and experience improved acceleration with less vibration and noise—potentially adding decades to your existing engine's lifecycle. It's all possible with a Caterpillar performance upgrade.

- Better Performance and Monitoring

Improve engine response with electronic unit injection. Reduce downtime with improved diagnostic capability.

- Cost Effectiveness

You'll experience significant fuel reduction, which means ongoing cost savings—all without the cost of removing and replacing the engine.

- Sustainability

Decreased fuel consumption leads to a reduction in greenhouse gas emissions.

Performance upgrades are currently available on select 3500 and 3600 engines, including genuine Cat parts bringing the customer's engines performance in line with current standards.



Watch this video!

**UPGRADE YOUR SPORTFISHING EXPERIENCE**

**CAT® C32B**

**DRIVEN BY**  
**TORQUE**  
**AND**  
**DETERMINATION**

**AVAILABLE FROM**  
**1800 to 2400 BHP**

**RATED SPEED**  
**2300 RPM**



**Customer Value Agreements**



# Marine CVAs

## Confidence on Board

### Why invest in a Customer Value Agreement (CVA)?

Caterpillar Marine can help you drive key business outcomes, such as achieving the lowest Total Cost of Ownership (TCO), optimizing the lifecycle of your engine and a lot more, with a customized CVA.

You likely have set expectations about the performance and lifecycle of your Marine assets and a recipe for meeting them. CVAs from your Cat® dealer provide you with exceptional structure, solutions and services for even better results.

Anchored in the security of Genuine Cat Parts and expert dealer support, CVAs ensure that all stakeholders – owners, operators, technicians – are informed of maintenance and repair needs, risks and any associated costs today and in the future to help you increase productivity and enhance your ownership experience.

With a Marine CVA, you structure the services you need to create the outcomes you want, including:

- **Self-service planned maintenance (PM) kits** enable a convenient, cost-effective solution that supports the lowest TCO.
- **Dealer-led repair options**, coupled with demand planning, help mitigate the risk of last-minute major repairs.
- **Data-driven insights** through digital solutions like Cat Remote Fleet Vision (RFV) identify capacity or uptime opportunities.



- **Financing or extended service coverage (ESC) options** help you manage your cash flow and mitigate unexpected costs.
- **Engine upgrades and other services** help you minimize fuel usage, decrease your engine's environmental impact, lower TCO and meet emissions standards. Regardless of where you are in your energy transition, services from Caterpillar can provide visibility to your emissions and drive reductions through emissions assessments.

**Contact your Cat dealer for more information about how a Marine CVA can help you achieve key outcomes.** Whether you choose self-service or dealer-supported options, or select services direct from Caterpillar, you can tailor your CVAs to support newly delivered, mid-life or end-of-life engines for the solution that works best for you!



# CAT<sup>®</sup> C7.1

EU STAGE V\* • U.S. EPA Tier 3  
CHINA STAGE II

## FLEXIBILITY TO NAVIGATE NEW WATERS

### C7.1 Marine Auxiliary Engine

109 bkW – 164 bkW @1500 rpm  
129 bkW – 218 bkW @1800 rpm

### C7.1 Marine Generator Set

100 ekW – 150 ekW @1500 rpm  
118 ekW – 200 ekW @1800 rpm

### C7.1 Marine Variable Speed

Auxiliary Engine  
129 bkW – 149 bkW – 186 bkW  
(600 – 2400 rpm)



Watch the Video

\* Refer to product pages for more detail.

## EMD Medium-Speed Diesel and Dual Fuel Solutions



# EMD Propulsion and Dual Fuel Engines

## EMD E 23 & E 23B (710 Series) Marine Propulsion and Generator Set Engines

EMD Engines have been in the marine propulsion business since 1935. EMD brings two-cycle medium-speed engines to the Caterpillar Marine family, with over 78,000 engines delivered globally, making it one of the largest medium-speed engine families in operation around the world.

Built on the successful 710 Series, the current EMD product line consists of medium-speed two-cycle diesel and dual fuel engines models ranging in power from 1490 to 4100 kW.

The E 23 (IMO II/U.S. EPA Tier 3) and E 23B (IMO III/ U.S. EPA Tier 4) are available in 8, 12, 16 and 20 cylinder configurations with continuous power ratings from 1249 bkW (1675 hp) to 3729 bkW (5000 hp).



## E 23B Specifications

- IMO III emissions compliant
- Meets the U.S. EPA Tier 4 emission standard
- 200 rpm minimum idle speed
- 900 rpm maximum rated speed
- 230 mm bore x 279 mm stroke
- Welded 710 Series “G” Crankcase
- Turbocharged-aftercooled aspiration
- Electronically governed
- Available as clockwise or counterclockwise rotation
- Engine diagnostics and general alarm
- Programmable parameters

## The EMD E 23 Series offers the following features:

### Performance Advantage

- Performance of a high-speed engine, with the durability advantage of a medium-speed engine
- Excellent transient response. Idle to full power in 10 seconds in fixed pitch propeller applications
- 200 rpm low idle speed improves fuel efficiency and operating range flexibility

### Total Cost of Ownership Advantage

- 30,000 hour or greater overhaul interval with no midlife top end overhaul or oil change required
- Easy, non-invasive inspection of cylinder power assembly component for simple predictive maintenance
- Global dealer network for consistent service

### Emission Advantage

- Integrated SCR to optimize NO<sub>x</sub> reduction, fuel efficiency, and compact footprint
- Closed crankcase ventilation system and valve stem seals for additional PM reduction
- Meets U.S. EPA Tier 4 and IMO III emission standards

## Selective Catalytic Reduction (SCR) System

The EMD SCR system is co-designed by EMD and Caterpillar. The EMD SCR System has been developed especially for the EMD two cycle medium-speed engines to meet IMO III and U.S. EPA Tier 4 emission standards. Every component in the EMD SCR System is designed and manufactured to EMD product standards with highest quality.

### EMD E23B Model Standard SCR Configuration:

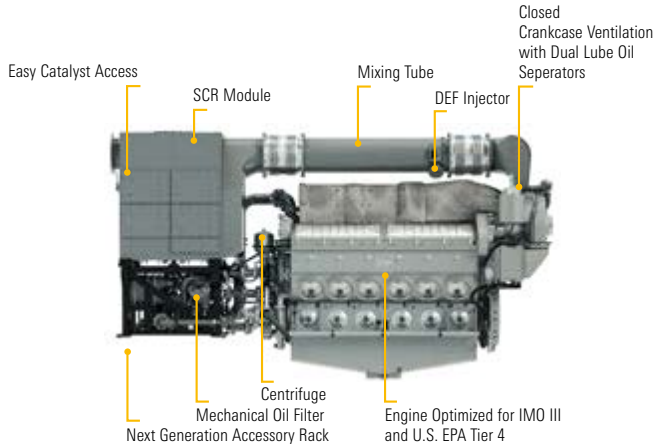

### EMD E23B Model Remotely Mounted SCR Configuration:

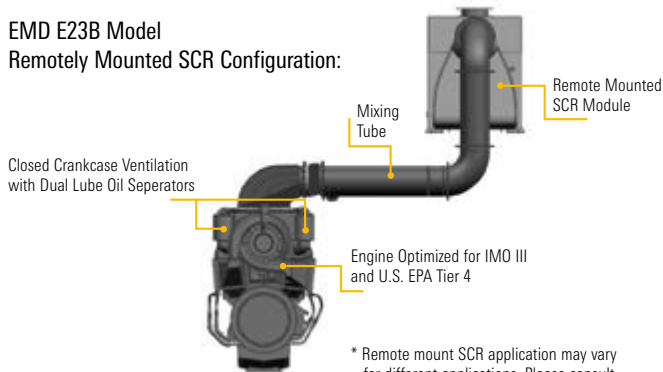

\* Remote mount SCR application may vary for different applications. Please consult your dealer for details.

## Biodiesel, Renewable Diesel and other Alternate Fuels

Progress Rail is committed to providing fuel flexibility for our new and existing customers. Biodiesel [FAME] and Renewable Diesel [HVO or HDRD] are two fuels that provide lower lifecycle greenhouse gas emissions while maintaining essentially the same GHGs at the stack when compared with diesel. EMD is committed to the operation and reliability of these fuels in the EMD engines – providing our customers economical and durable ways to reduce lifecycle GHGs. EMD currently approves the usage of up to 20% biodiesel blend (B20) and is testing additional blends of biodiesel and renewable diesel fuel in many applications.

EMD has developments in progress in other areas of alternate fuels. This includes work on methanol and natural gas, with a focus on assisting our customers' fuel flexibility efforts.

Consult your EMD Power Products Distributor or visit

[https://www.progressrail.com/en/Segments/Engines/Marine\\_Stationary\\_Engines.html](https://www.progressrail.com/en/Segments/Engines/Marine_Stationary_Engines.html)

for more information regarding Medium Speed Engines, dual fuel solutions, biodiesel and renewable diesel fuels.

# E 23

## DIMENSIONS (mm) AND WEIGHTS (kg)

Type	A	B	C	D	E	F	G	H	Engine Weight	Acc. Rack Weights
<b>8 E 23</b>	3246	2573	479	2790	2134	1864	6202	929	13,018	1723
<b>12 E 23</b>	3410	2764	632	2948	2240	2734	7178	1050	17,690	1723
<b>16 E 23</b>	3410	2764	632	2948	2240	3715	8171	1050	20,865	1723
<b>20 E 23</b>	3642	2966	835	3150	2240	4559	9015	1050	23,949	1769

## DIMENSIONS (in) AND WEIGHTS (lb)

Type	A	B	C	D	E	F	G	H	Engine Weight	Acc. Rack Weights
<b>8 E 23</b>	127.8	101.3	18.9	109.9	84.0	73.4	244.2	36.6	28,700	3799
<b>12 E 23</b>	134.3	108.8	24.9	116.1	88.2	107.6	282.6	41.3	39,000	3799
<b>16 E 23</b>	134.3	108.8	24.9	116.1	88.2	146.3	321.7	41.3	45,999	3799
<b>20 E 23</b>	143.4	116.8	32.9	124.0	88.2	179.5	354.9	41.3	52,799	3900

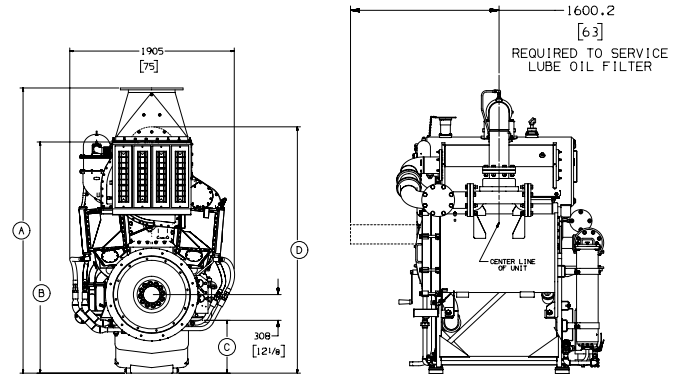
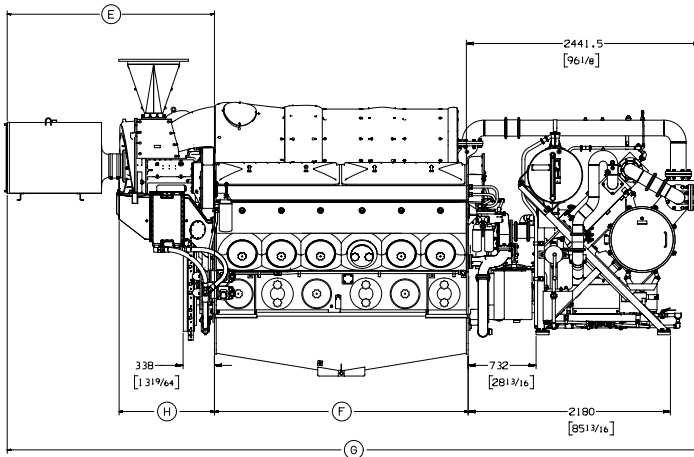

(shown with accessory rack)

## TECHNICAL DATA

Model	Cylinders	Rating	bkW	bhp	rpm	g/bkW-h	IMO	U.S. g/h	EPA
<b>8 E 23</b>	8	CS	1491	2000	900	201	II	93	T3
<b>12 E 23</b>	12	CS	2237	3000	900	198	II	138	T3
<b>16 E 23</b>	16	CS	2983	4000	900	196	II	182	T3
<b>20 E 23</b>	20	CS	3729	5000	900	209	II	236	T3
<b>8 E 23</b>	8	INT	1641	2200	900	200	II	103	T3
<b>12 E 23</b>	12	INT	2461	3300	900	197	II	152	T3
<b>16 E 23</b>	16	INT	3281	4400	900	195	II	201	T3
<b>20 E 23</b>	20	INT	4101	5500	900	210	II	261	T3

**Note:** EMD E 23 engines were formerly EMD 710 Series. INT equals Intermittent Service Rating. CS equals Continuous Service Rating. 750 rpm (50 Hz) and dual fuel options are available. Contact local dealer for detail.

# E 23B

## DIMENSIONS (mm) AND WEIGHTS (kg)

Type	A	B	C	D	E	F	G	H	Engine Weight	Acc. Rack Weight
<b>8 E 23B</b>	3533	2573	479	2740	2034	1864	5572	1038	14808	3562
<b>12 E 23B</b>	3685	2764	632	2836	2034	2734	6591	1143	19608	3562
<b>16 E 23B</b>	3685	2764	632	2836	2034	3715	7548	1143	21339	3904

## DIMENSIONS (in) AND WEIGHTS (lb)

Type	A	B	C	D	E	F	G	H	Engine Weight	Acc. Rack Weight
<b>8 E 23B</b>	139.1	101.3	18.9	107.9	80.1	73.4	219.4	40.9	32646	7853
<b>12 E 23B</b>	145.1	108.8	24.9	111.7	80.1	107.6	259.5	45.0	43228	7853
<b>16 E 23B</b>	145.1	108.8	24.9	111.7	80.1	146.3	297.2	45.0	47044	8607

Note: Completely Integrated System

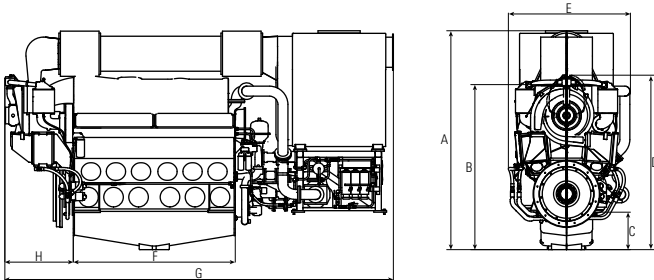

## TECHNICAL DATA

Model	Cylinders	Rating	bkW	bhp	rpm	IMO	EPA	EU
<b>8 E 23B</b>	8	CS	1491	2000	900	III	T 4	NC
<b>12 E 23B</b>	12	CS	2237	3000	900	III	T 4	NC
<b>16 E 23B</b>	16	CS	2983	4000	900	III	T 4	NC
<b>20 E 23B*</b>	20	CS	3729	5000	900	III	T 4	NC
<b>8 E 23B</b>	8	INT	1641	2200	900	III	T 4	NC
<b>12 E 23B</b>	12	INT	2461	3300	900	III	T 4	NC
<b>16 E 23B</b>	16	INT	3281	4400	900	III	T 4	NC
<b>20 E 23B*</b>	20	INT	4101	5500	900	III	T 4	NC

Note: INT equals Intermittent rating

\* Contact your local dealer for details

## E 23B Enhancements:

- IMO III and U.S. EPA Tier 4
- Completely integrated SCR System – no need to worry about mounting or where to place it in the engine room
- Closed crankcase
- High pressure lube oil system
- Mechanical oil filtration with centrifuge
- Next generation Accessory Rack

## Standard Equipment

- EMDEC/CAT ADEM Engine control module, including EUI injectors, wiring harness and sensors.
- Fuel pump, duplex spin-on primary filters/bypass, and manual priming pump.
- Single oil pump, cooler, strainer, centrifuge, self-cleaning filter, turbocharger primary and soakback filter
- Gear-driven HT and LT centrifugal coolant pumps and automatic thermostatic valves
- Single-stage scavenging air turbocharger with two (2) aftercoolers.
- Individual cylinder exhaust thermocouples and exhaust manifold thermal blankets (SOLAS)
- SCR Module, DEF dosing cabinet, DEF mixing tube, and flex connections
- Air start system

## Options

- Marine society certifications
- Alarm & Protection panels and remote displays
- Power takeoff (free end).
- Main bearing thermocouples
- Vibration isolation mounts
- Torsional Vibration Analysis.
- Custom color finish paint (cement gray standard).
- Engine-driven sea water pump
- Oil mist detection
- Water expansion tanks (HT & LT)
- Close-coupled intake air filter
- Closed crankcase ventilation

## Rating Definitions and Conditions

**Continuous Service Rating** is suitable for continuous duty applications with no limit on operating hours at maximum load. **Intermittent Rating** is suitable for continuous duty applications involving varying loads. Maximum engine power produced is limited by application guidelines, leaving a power reserve for intermittent operating conditions. Operating time at loads above the Continuous Service Rating is limited to one hour in 12 or 8% of total operating hours.

# GLOSSARY



# Emissions Standards

U.S. Environmental Protection Agency (EPA), Transport Canada, China Ministry of the Environment and the European Union have enacted programs to reduce emissions from all domestic diesel vessels. International vessels are subject to the requirements of the country where the vessel is registered (flagged) and if regulated, typically follow the requirements of the International Maritime Organization (IMO). Caterpillar Marine has a key focus on emissions regulations to ensure that our marine engines meet global requirements. Caterpillar continues to support our customers as they navigate the evolving energy landscape.

## U.S. EPA Standards

U.S. EPA applies for marine diesel engines installed in a variety of U.S. flagged recreational and workboat vessels.

### High Performance Applications:

**EPA Tier 3:** Cat C7.1, C18 & C32

### Commercial Applications:

**EPA Tier 3:** Cat C1.5, C2.2, C4.4, C7.1, C9.3, C18, C32 (< 600 kW)

**EPA Tier 4:** Cat C32, 3500, C280 (> 600 kW)

## Glossary of U.S. EPA Regulatory References

<b>NC</b>	Not U.S. EPA Marine Certified for use in the U.S. or Canada.
<b>T3C</b>	Meets U.S. EPA Marine Tier 3 Commercial standards.
<b>T3R</b>	Meets U.S. EPA Marine Tier 3 Recreational standards.
<b>T3CR</b>	Meets U.S. EPA Marine Tier 3 Commercial standards and U.S. EPA Marine Tier 3 Recreational standards.
<b>T4C</b>	Meets U.S. EPA Marine Tier 4 Final Commercial standards.
<b>Emergency</b>	Meets U.S. EPA Marine Tier 2 or Tier 3, as applicable for emergency power.

## Canada Regulations

As of January 1, 2016, Category 2 engines (7 to 30 L/cylinder) on Canadian flagged vessels must meet U.S. EPA requirements or have an equivalent certificate that has been provided by another country. Unless otherwise exempted, all other marine engines must meet IMO requirements for vessels constructed after January 1, 2016 (IMO III). Engines on vessels of equal or less than 15 meters in length with a combined propulsion power of less than 750 kW must meet IMO II emission standards.

## China Regulations

China Domestic Marine regulation (GB15097) China Stage II went into effect after July 1, 2022. International vessels subject to the requirements of IMO are not subject to China Domestic Marine regulations.

### Engine Certification Descriptions

**C-II** Engines meeting China inland water regulations.

## IMO Certification

The International Maritime Organization (IMO) regulates exhaust gas emissions on diesel engines > 130 kW. Since January 1, 2011 the IMO has regulated NO<sub>x</sub> exhaust emission to their prescribed IMO II levels except for special emissions control areas (ECA's). There are seven NO<sub>x</sub> emission control areas that are or will be subject IMO II to IMO III. These include the North American ECA, Canadian Arctic ECA, Norwegian Sea ECA, North East Atlantic ECA, U.S. Caribbean ECA, North Sea ECA, and the Baltic Sea ECA. Vessels that operate within these ECA's must be compliant with IMO III. Engines that are used for emergency power are not subject to IMO regulations.

## EU Certification

### Commercial Marine Engine Regulation 2016/1628 (EU Stage V)

This directive is in effect and applies to all propulsion and auxiliary engines. Caterpillar has certified some engines with a rated power of greater than 560 kW to this standard. Most of these are to be used for inland waterway vessels. These engines also became effective by reciprocity agreement with CCNR Stage II, on July 1, 2007. (97/68 directive was repealed January 1, 2017 although 97/68 (IIIA) standards apply to marine engines until Stage V came into effect January 1, 2019 for < 300 kW and January 1, 2020 for ≥ 300 kW and all references to 97/68 are now references to EU 2016/1628 (Stage V)).

### Engine Certification Descriptions

- IW** Meets EU Directive 2016/1629 Technical Requirements for Inland Waterway.
- NC** Not Certified for specific regulations.
- NST** Engines ≤ 19 kW are not subject to EU Directive 2016/1629.
- RCD** Recreational Craft Directive, meets 2013/53/EU.  
This directive is in effect and applies to all recreational engines used in the European Union areas.
- EUV** Engines meeting Stage V.

# Marine Rating Definition

## Propulsion Engines

Rating definitions provide guidelines to help determine the appropriate rating for specific applications based on vessel operation. Cat marine propulsion engine rating applications for C7.1 through 3516E are based on load factor, time at full throttle, and operational hours per year.

Contact your local Cat dealer for assistance in determining the appropriate rating for your specific application.

### A Rating (Unrestricted Continuous)

**Typical applications:** For vessels operating at rated load and rated speed up to 100% of the time without interruption or load cycling (80% to 100% load factor).

Typical operation ranges from 5000 to 8000 hours per year.

### B Rating (Heavy Duty)

**Typical applications:** For vessels operating at rated load and rated speed up to 80% of the time with some load cycling (40% to 80% load factor).

Typical operation ranges from 3000 to 5000 hours per year.

### C Rating (Maximum Continuous)

**Typical applications:** For vessels operating at rated load and rated speed up to 50% of the time with cyclical load and speed (20% to 80% load factor).

Typical operation ranges from 2000 to 4000 hours per year.

### D Rating (Intermittent Duty)

**Typical applications:** For vessels operating at rated load and rated speed up to 16% of the time (up to 50% load factor).

Typical operating ranges from 1000 to 3000 hours per year.

### E Rating (High Performance)

**Typical applications:** For vessels operating at rated load and rated speed up to 8% of the time (up to 30% load factor).

Typical operation ranges from 250 to 1000 hours per year.

### For C280-6, C280-8, C280-12 and C280-16

#### Engines Only:

**Continuous Service (CS) Rating** is suitable for continuous duty applications, including dredges, for operation without interruption or load cycling. Up to 100% of the time at 80-100% load factor.

### For C280-6, C280-8, C280-12, C280-16, and EMD E 23

#### Engines Only:

**Maximum Continuous (MC) Rating** or EMD Intermittent rating is generally used for vessel applications involving varying loads. The engine power actually produced is limited by application guidelines, leaving a power reserve for unusual operating conditions. Operating time at loads above the Continuous Service Rating for a given rpm is limited to one hour out of every 12. or 8.3% of total operating hours.

**FCVR – Fast Commercial Vessel Rating:** 85% of operating hours at rated speed, 15% of hours at less than 50% rated power. TBO approximately 20,000 - 25,000 hours. The propulsion system design should consider heavy ship condition, sea state, hull fouling and propulsion system power losses for proper match between engine and prop/jet.

### DEP Ratings (Diesel Electric Propulsion, Electric Drive)

**Typical applications:** For vessels operating with generator sets that provide power to the propulsion systems. All ratings are Prime Ratings according to ISO 8528-1 for unlimited usage per year at a load factor of  $\leq 70\%$ . 10% overload capability is required for a maximum of 1 hour out of every 12 and a maximum of 25 hours total per year.

**Typical applications could include but are not limited to supply vessels, cruise vessels, research vessels, or any other ship using diesel electric drive systems.**

## Rating Conditions for 3500s and Smaller Engines

Ratings are based on SAE J1228 standard conditions of 29.61 in Hg (100 kPa) and 77 °F (25 °C). These ratings also apply at ISO3046-1:2002E, ISO8665, DIN6271-3, and BS5514 conditions of 29.61 in Hg (100 kPa), 81 °F (27 °C) and 60% relative humidity.

Caterpillar maintains ISO9001 certified quality management systems for engine test facilities to assure accurate calibration of test equipment. Electronically controlled engines are set at the factory at the advertised power corrected to standard ambient conditions. The published fuel consumption rates are in accordance with ISO3046-1:2002E.

**Fuel consumption** is based on SAE J1995 with +/- 3% tolerance at rated power for fuel having an LHV of 18,390 Btu/lb (42,780 kJ/kg) when used at 84.2 °F (29 °C) and weighing 7.001 lb/gal (U.S.) (838.9 g/L). Additional ratings may be available for specific customer requirements. Consult your Cat representative for details.

## Rating Conditions for C280 Engines

Ratings are based on SAE J1349 standard conditions of 29.61 in Hg (100 kPa) and 77 °F (25 °C). These ratings also apply at ISO3046-1:2002E, ISO8665, DIN6271-3, and BS5514 standard reference conditions. Ratings also meet classification society maximum temperature requirements of 113 °F (45 °C) temperature to turbo and 90 °F (32 °C) seawater temperature without derate.

**Fuel consumption** is based on ISO3046/1 with +5% tolerance at rated power for fuel having an LHV of 18,390 Btu/lb (42,780 kJ/kg) and weighing 7.001 lb/gal (U.S.) (838.9 gal/liter). Includes engine mounted fresh water and lube oil pumps. BSFC without pumps, 2% less. Additional ratings may be available for specific customer requirements. Consult your Cat representative for details.

## Performance Data

Power rated in accordance with NMMA procedure as crankshaft power. For units equipped with Caterpillar supplied marine gears, reduce crankshaft power by 3% for propeller shaft power.

# Marine Rating Definition Generator Sets and Auxiliary Engines

Caterpillar has offered packaged power systems for over 70 years. We verify power and performance ratings, as advertised, through extensive factory testing.

Cat generator sets typically exceed NEMA and IEEE standards for load acceptance. All rotor designs have been tested to at least 120% overspeed at 338 °F (170 °C) ambient temperature.

## Rating Definition

All Cat marine auxiliary engines and generator sets are rated for prime power for continuous electric service according to ISO 8528-1.

Hours per Year	Unlimited
Load Factor	< 70%
Overload Capacity	+ 10%
	maximum of 1 hour out of every 12 hours
	maximum of 25 hours total per year

## Rating Conditions

Ratings are based on SAE J3046 and J1349 standard conditions of 29.61 inHg (100 kPa) and 77 °F (25 °C). These ratings also apply at ISO8665, ISO3046-1:2002E, DIN6271-3, and BS5514 standard conditions of 29.61 in. Hg (100 kPa), 81 °F (27 °C), and 60% relative humidity.

Fuel rates are based on fuel oil of 35° API [60 °F (16 °C)] gravity having an LHV of 18,390 Btu/lb (42 780 kJ/kg) when used at 85 °F (29 °C) and weighing 7.001 lb/gal (U.S.). (838.9 gal/L).

Marine Auxiliary Engines are mainly used as generator set engines; however, they can be used for mechanically driven pumps, winches, conveyors, thrusters, when it is specified. Engines can be radiator cooled or heat exchanger/keel cooled.

# Abbreviations

<b>bhp</b>	Brake Horsepower	<b>MCS</b>	Marine Classification Society
<b>bkW</b>	Brake Kilowatts	<b>NA</b>	Naturally Aspirated
<b>CEM</b>	Clean Emission Module	<b>R</b>	Radiator Cooled
<b>DEF</b>	Diesel Exhaust Fluid	<b>SAE</b>	Society of Automotive Engineers
<b>DIN</b>	German Standards Organization	<b>SCAC</b>	Separate Circuit Aftercooled
<b>DF</b>	Dual Fuel	<b>SCR</b>	Selective Catalytic Reduction
<b>ekW</b>	Electrical Kilowatts	<b>STA</b>	Sequential Turbocharged Aftercooled
<b>EPA</b>	Environmental Protection Agency	<b>T</b>	Turbocharged
<b>EU</b>	European Union	<b>TA</b>	Turbocharged, Aftercooled
<b>EUI</b>	Electronic Unit Injection	<b>TTA</b>	Twin Turbo Aftercooled
<b>g/bkWh</b>	Grams per Brake Kilowatt Hour	<b>gal/h (U.S.)</b>	U.S. Gallons per Hour
<b>H</b>	Height of Engine	<b>W</b>	Overall Width
<b>HE</b>	Heat Exchanger Cooled		
<b>IMO</b>	International Maritime Organization		
<b>ISO</b>	International Standards Organization		
<b>kVA</b>	Kilovolt-Ampere		
<b>L</b>	Overall Engine Length		

# Global Dealer Network

Caterpillar's global dealer network has broad capabilities and has a strong global presence, allowing customer access to complete solutions for your equipment needs. From people at the local branch to those at the corporate level – we offer global support at the local level. Service locations offer dealer personnel who know and understand their local industry, their customers, and their customers' businesses.

Cat dealer field service capability is exceptional. Your uptime is increased with prompt response times, and qualified, experienced field service technicians with the expertise and equipment to quickly diagnose and fix problems. Our technicians know Cat products and solutions, and deliver the same world-class support to you – wherever and whenever you need it.



To find your nearest dealer, please visit:  
[https://www.cat.com/en\\_US/support/dealer-locator.html](https://www.cat.com/en_US/support/dealer-locator.html)



**HEADQUARTERS****Caterpillar Marine**

10203 Sam Houston Park Dr  
Houston, TX 77064/USA

**EUROPE, AFRICA, MIDDLE EAST****Caterpillar Marine**

Große Elbstraße 279 a  
22767 Hamburg/Germany

**Caterpillar Marine Power UK Ltd.**

22 Cobham Road  
Wimborne  
Dorset  
BH21 7 PW  
United Kingdom

**ASIA-PACIFIC****Caterpillar Marine Trading (Shanghai)****Co., Ltd**

19/F, Caterpillar Marine Center  
1319, Yan'an West Road  
200050 Shanghai/P.R. China

**Caterpillar Marine Asia Pacific Pte Ltd**

No. 5 Tukang Innovation Grove  
Singapore 618304  
Republic of Singapore

**Caterpillar SARL Middle East**

Jebel Ali Free Zone, South 3,  
P.O.Box 262147  
Dubai, United Arab Emirates

For more information  
please visit:  
[www.cat.com/marine](http://www.cat.com/marine)



**CATERPILLAR**

© 2025 Caterpillar. All Rights Reserved. CAT, CATERPILLAR, LET'S DO THE WORK, their respective logos, "Caterpillar Yellow", the "Power Edge" and Cat "Modern Hex" trade dress as well as corporate and product identity used herein, are trademarks of Caterpillar and may not be used without permission.

LEDM3457-31