

Operation and Maintenance Manual

1600 Series Industrial Engine

XGA (Engine)
XGB (Engine)
XGD (Engine)
XGE (Engine)
XGF (Engine)
XGH (Engine)

Important Safety Information

Most accidents that involve product operation, maintenance and repair are caused by failure to observe basic safety rules or precautions. An accident can often be avoided by recognizing potentially hazardous situations before an accident occurs. A person must be alert to potential hazards. This person should also have the necessary training, skills and tools to perform these functions correctly.

Incorrect operation, lubrication, maintenance or repair of this product can be dangerous and could result in injury or death.

Do not operate or perform any lubrication, maintenance or repair on this product, until you have read and understood the operation, lubrication, maintenance and repair information.

Safety precautions and warnings are provided in this manual and on the product. If these hazard warnings are not heeded, bodily injury or death could occur to you or to other persons.

The hazards are identified by the "Safety Alert Symbol" and followed by a "Signal Word" such as "DANGER", "WARNING" or "CAUTION". The Safety Alert "WARNING" label is shown below.



The meaning of this safety alert symbol is as follows:

Attention! Become Alert! Your Safety is Involved.

The message that appears under the warning explains the hazard and can be either written or pictorially presented.

Operations that may cause product damage are identified by "NOTICE" labels on the product and in this publication.

Perkins cannot anticipate every possible circumstance that might involve a potential hazard. The warnings in this publication and on the product are, therefore, not all inclusive. You must not use this product in any manner different from that considered by this manual without first satisfying yourself that you have considered all safety rules and precautions applicable to the operation of the product in the location of use, including site-specific rules and precautions applicable to the worksite. If a tool, procedure, work method or operating technique that is not specifically recommended by Perkins is used, you must satisfy yourself that it is safe for you and for others. You should also ensure that you are authorized to perform this work, and that the product will not be damaged or become unsafe by the operation, lubrication, maintenance or repair procedures that you intend to use.

The information, specifications, and illustrations in this publication are on the basis of information that was available at the time that the publication was written. The specifications, torques, pressures, measurements, adjustments, illustrations, and other items can change at any time. These changes can affect the service that is given to the product. Obtain the complete and most current information before you start any job. Perkins dealers or Perkins distributors have the most current information available.



When replacement parts are required for this product Perkins recommends using Perkins replacement parts.

Failure to heed this warning can lead to premature failures, product damage, personal injury or death.

In the United States, the maintenance, replacement, or repair of the emission control devices and systems may be performed by any repair establishment or individual of the owner's choosing.

Table of Contents

Foreword	4
----------------	---

Safety Section

Safety Messages	6
-----------------------	---

General Hazard Information	8
----------------------------------	---

Burn Prevention	12
-----------------------	----

Fire Prevention and Explosion Prevention	13
--	----

Crushing Prevention and Cutting Prevention ..	15
---	----

Mounting and Dismounting	15
--------------------------------	----

High Pressure Oil Lines	15
-------------------------------	----

Before Starting Engine	16
------------------------------	----

Engine Starting	17
-----------------------	----

Engine Stopping	17
-----------------------	----

Electrical System	18
-------------------------	----

Engine Electronics	18
--------------------------	----

Product Information Section

General Information	20
---------------------------	----

Product Identification Information	25
--	----

Operation Section

Lifting and Storage	30
---------------------------	----

Features and Controls	31
-----------------------------	----

Engine Diagnostics	42
--------------------------	----

Engine Starting	43
-----------------------	----

Engine Operation	45
------------------------	----

Cold Weather Operation	46
------------------------------	----

Engine Stopping	49
-----------------------	----

Maintenance Section

Refill Capacities	50
-------------------------	----

Maintenance Recommendations	63
-----------------------------------	----

Maintenance Interval Schedule	66
-------------------------------------	----

Warranty Section

Warranty Information	90
----------------------------	----

Index Section

Index	91
-------------	----

Foreword

California Proposition 65 Warning

Diesel engine exhaust and some of its constituents are known to the State of California to cause cancer, birth defects, and other reproductive harm.



WARNING – This product can expose you to chemicals including ethylene glycol, which is known to the State of California to cause birth defects or other reproductive harm. For more information go to:

www.P65Warnings.ca.gov

Do not ingest this chemical. Wash hands after handling to avoid incidental ingestion.



WARNING – This product can expose you to chemicals including lead and lead compounds, which are known to the State of California to cause cancer, birth defects, or other reproductive harm. For more information go to:

www.P65Warnings.ca.gov

Wash hands after handling components that may contain lead.

Literature Information

This manual contains safety, operation instructions, lubrication, and maintenance information. This manual should be stored in or near the engine area in a literature holder or literature storage area. Read, study, and keep the manual with the literature and engine information.

English is the primary language for all Perkins publications. The English used facilitates translation and consistency.

Some photographs or illustrations in this manual show details or attachments that may be different from your engine. Guards and covers may have been removed for illustrative purposes. Continuing improvement and advancement of product design may have caused changes to your engine which are not included in this manual. Whenever a question arises regarding your engine, or this manual, please consult with your Perkins dealer or your Perkins distributor for the latest available information.

Safety

This safety section lists basic safety precautions. In addition, this section identifies hazardous, warning situations. Read and understand the basic precautions listed in the safety section before operating or performing lubrication, maintenance, and repair on this product.

Operation

Operating techniques outlined in this manual are basic. The operating techniques assist with developing the skills and techniques required to operate the engine more efficiently and economically. Skill and techniques develop as the operator gains knowledge of the engine and the capabilities of the engine.

The operation section is a reference for operators. Photographs and illustrations guide the operator through procedures of inspecting, starting, operating, and stopping the engine. This section also includes a discussion of electronic diagnostic information.

Maintenance

The maintenance section is a guide to engine care. The illustrated, step-by-step instructions are grouped by service hours and/or calendar time maintenance intervals. Items in the maintenance schedule are referenced to detailed instructions that follow.

Recommended service should be performed at the appropriate intervals as indicated in the Maintenance Interval Schedule. The actual operating environment of the engine also governs the Maintenance Interval Schedule. Therefore, under severe, dusty, wet, or freezing cold operating conditions, more frequent lubrication, and maintenance than is specified in the Maintenance Interval Schedule may be necessary.

The maintenance schedule items are organized for a preventive maintenance management program. If the preventive maintenance program is followed, a periodic tune-up is not required. The implementation of a preventive maintenance management program should minimize operating costs through cost avoidances resulting from reductions in unscheduled downtime and failures.

Maintenance Intervals

Perform maintenance on items at multiples of the original requirement. Each level and/or individual items in each level should be shifted ahead or back depending upon your specific maintenance practices, operation, and application. Perkins recommends that the maintenance schedules be reproduced and displayed near the engine as a convenient reminder. Perkins also recommends that a maintenance record be maintained as part of the permanent record of the engine.

Your authorized Perkins dealer or your Perkins distributor can assist you in adjusting your maintenance schedule to meet the needs of your operating environment.

Overhaul

Major engine overhaul details are not covered in the Operation and Maintenance Manual except for the interval and the maintenance items in that interval. Major repairs are best left to trained personnel or an authorized Perkins distributor or dealer. Your Perkins dealer or your Perkins distributor offers various options regarding overhaul programs. If you experience a major engine failure, there are also numerous after failure overhaul options available. Consult with your Perkins dealer or your Perkins distributor for information regarding these options.

Safety Section

i04257112

Safety Messages

There may be several specific warning signs on your engine. The exact location and a description of the warning signs are reviewed in this section. Please become familiar with all warning signs.

Ensure that all of the warning signs are legible. Clean the warning signs or replace the warning signs if the words cannot be read or if the illustrations are not visible. Use a cloth, water, and soap to clean the warning signs. Do not use solvents, gasoline, or other harsh chemicals. Solvents, gasoline, or harsh chemicals could loosen the adhesive that secures the warning signs. The warning signs that are loosened could drop off the engine.

Replace any warning sign that is damaged or missing. If a warning sign is attached to a part of the engine that is replaced, install a new warning sign on the replacement part. Your Perkins distributor can provide new warning signs.

(1) Universal Warning



Do not operate or work on this equipment unless you have read and understand the instructions and warnings in the Operation and Maintenance Manuals. Failure to follow the instructions or heed the warnings could result in serious injury or death.

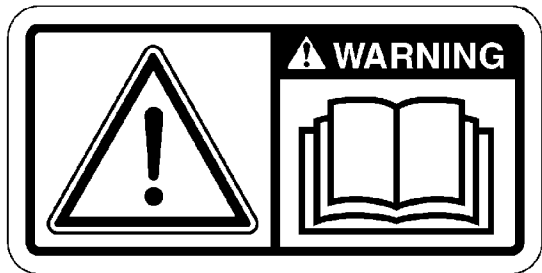

Illustration 1
Typical example

g01154807

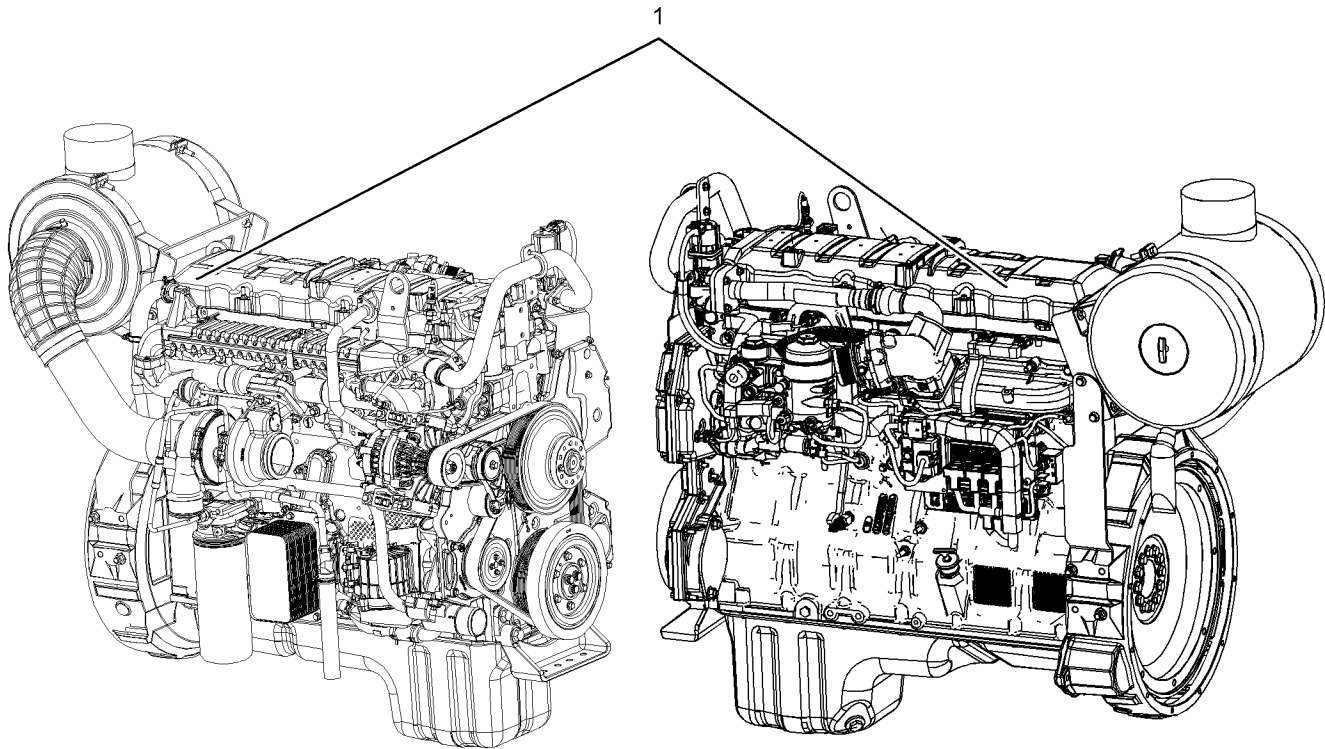

Illustration 2

g02428016

(1) Universal warning

The universal warning labels (1) are located on the rear left side of the valve mechanism cover and the rear right side of the valve mechanism cover.

(2) Hand (High Pressure)

WARNING

Contact with high pressure fuel may cause fluid penetration and burn hazards. High pressure fuel spray may cause a fire hazard. Failure to follow these inspection, maintenance and service instructions may cause personal injury or death.

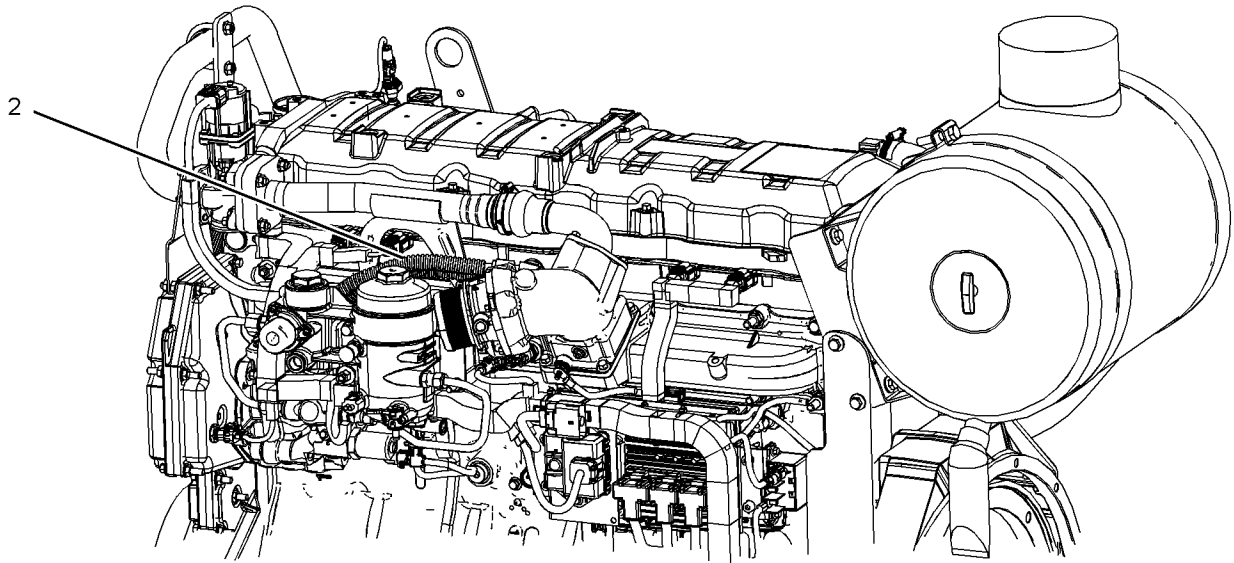

Illustration 3

g02835016

(2) Hand (High Pressure)

The warning label for the Hand (High Pressure) (2) is a wrap around label that is installed on the high-pressure oil line.

i08344120

General Hazard Information

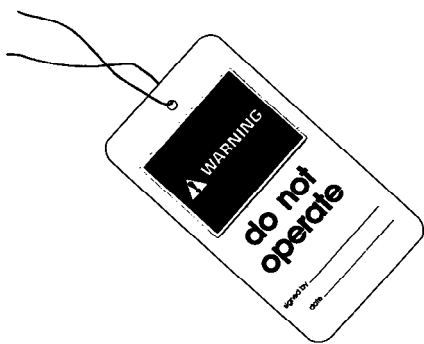

Illustration 4

g00104545

Attach a “Do Not Operate” warning tag or a similar warning tag to the start switch or to the controls before the engine is serviced or before the engine is repaired. Attach the warning tags to the engine and to each operator control station. When appropriate, disconnect the starting controls.

Do not allow unauthorized personnel on the engine, or around the engine when the engine is being serviced.

- Tampering with the engine installation or tampering with the OEM supplied wiring can be dangerous. Personal injury, death and/or engine damage could result.
- Vent the engine exhaust to the outside when the engine is operated in an enclosed area.
- Wear a hard hat, protective glasses, and other protective equipment, as required.
- When work is performed around an engine that is operating, wear protective devices for ears in order to help prevent damage to hearing.
- Do not wear loose clothing or jewelry that can snag on controls or on other parts of the engine.
- Ensure that all protective guards and all covers are secured in place on the engine.
- Never put maintenance fluids into glass containers. Glass containers can break.
- Use all cleaning solutions with care.
- Report all necessary repairs.

Unless other instructions are provided, perform the maintenance under the following conditions:

- The engine is stopped. Ensure that the engine cannot be started.
- The protective locks or the controls are in the applied position.

- Disconnect the batteries when maintenance is performed or when the electrical system is serviced. Disconnect the battery ground leads. Tape the leads in order to help prevent sparks.
- Disconnect the connector for the unit injector that is located on the valve cover base. This will help prevent personal injury from the high voltage to the unit injectors. Do not come in contact with the unit injector terminals while the engine is operating.
- Do not attempt any repairs or any adjustments to the engine while the engine is operating.
- Do not attempt any repairs that are not understood. Use the proper tools. Replace any equipment that is damaged or repair the equipment.
- For initial start-up of a new engine or for starting an engine that has been serviced, make provisions to stop the engine if an overspeed occurs. This may be accomplished by shutting off the fuel supply and/or the air supply to the engine.
- Start the engine from the operators station (cab). Never short across the starting motor terminals or the batteries. This could bypass the engine neutral start system and/or the electrical system could be damaged.

Engine exhaust contains products of combustion which may be harmful to your health. Always start the engine and operate the engine in a well ventilated area. If the engine is in an enclosed area, vent the engine exhaust to the outside.

Cautiously remove the following parts. To help prevent spraying or splashing of pressurized fluids, hold a rag over the part that is being removed.

- Filler caps
- Grease fittings
- Pressure taps
- Breathers
- Drain plugs

Use caution when cover plates are removed. Gradually loosen, but do not remove the last two bolts or nuts that are located at opposite ends of the cover plate or the device. Before removing the last two bolts or nuts, pry the cover loose in order to relieve any spring pressure or other pressure.

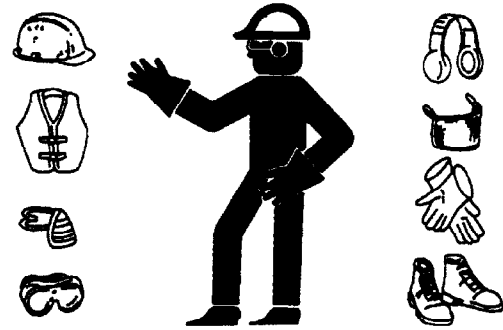

Illustration 5

g00702020

- Wear a hard hat, protective glasses, and other protective equipment, as required.
- When work is performed around an engine that is operating, wear protective devices for ears in order to help prevent damage to hearing.
- Do not wear loose clothing or jewelry that can snag on controls or on other parts of the engine.
- Ensure that all protective guards and all covers are secured in place on the engine.
- Never put maintenance fluids into glass containers. Glass containers can break.
- Use all cleaning solutions with care.
- Report all necessary repairs.

Unless other instructions are provided, perform the maintenance under the following conditions:

- The engine is stopped. Ensure that the engine cannot be started.
- Disconnect the batteries when maintenance is performed or when the electrical system is serviced. Disconnect the battery ground leads. Tape the leads in order to help prevent sparks.
- Do not attempt any repairs that are not understood. Use the proper tools. Replace any equipment that is damaged or repair the equipment.

Hexavalent Chromium

Perkins equipment and replacement parts comply with applicable regulations and requirements where originally sold. Perkins recommends the use of only genuine Perkins replacement parts.

Hexavalent chromium has occasionally been detected on exhaust and heat shield systems on Perkins engines. Although laboratory testing is the only accurate way to know if hexavalent chromium is, in fact, present, the presence of a yellow deposit in areas of high heat (for example, exhaust system components or exhaust insulation) may be an indication of the presence of hexavalent chromium.

Use caution if you suspect the presence of hexavalent chromium. Avoid skin contact when handling items that you suspect may contain hexavalent chromium, and avoid inhalation of any dust in the suspect area. Inhalation of, or skin contact with, hexavalent chromium dust may be hazardous to your health.

If such yellow deposits are found on the engine, engine component parts, or associated equipment or packages, Perkins recommends following local health and safety regulations and guidelines, utilizing good hygiene, and adhering to safe work practices when handling the equipment or parts. Perkins also recommends the following:

- Wear appropriate Personal Protective Equipment (PPE)
- Wash your hands and face with soap and water prior to eating, drinking, or smoking, and also during rest room breaks, to prevent ingestion of any yellow powder
- Never use compressed air for cleaning areas suspected of containing hexavalent chromium
- Avoid brushing, grinding, or cutting materials suspected of containing hexavalent chromium
- Obey environmental regulations for the disposal of all materials that may contain or have come into contact with hexavalent chromium
- Stay away from areas that might have hexavalent chromium particles in the air.

Pressurized Air and Water

Pressurized air and/or water can cause debris and/or hot water to be blown out. This could result in personal injury.

When pressurized air and/or pressurized water is used for cleaning, wear protective clothing, protective shoes, and eye protection. Eye protection includes goggles or a protective face shield.

The maximum air pressure for cleaning purposes must be below 205 kPa (30 psi). The maximum water pressure for cleaning purposes must be below 275 kPa (40 psi).

Fluid Penetration

Pressure can be trapped in the hydraulic circuit long after the engine has been stopped. The pressure can cause hydraulic fluid or items such as pipe plugs to escape rapidly if the pressure is not relieved correctly.

Do not remove any hydraulic components or parts until pressure has been relieved or personal injury may occur. Do not disassemble any hydraulic components or parts until pressure has been relieved or personal injury may occur. Refer to the OEM information for any procedures that are required to relieve the hydraulic pressure.

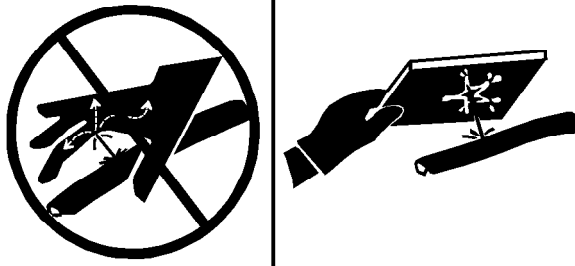

Illustration 6

g00687600

Always use a board or cardboard when you check for a leak. Leaking fluid that is under pressure can penetrate body tissue. Fluid penetration can cause serious injury and possible death. A pin hole leak can cause severe injury. If fluid is injected into your skin, you must get treatment immediately. Seek treatment from a doctor that is familiar with this type of injury.

Containing Fluid Spillage

NOTICE

Care must be taken to ensure that fluids are contained during performance of inspection, maintenance, testing, adjusting and repair of the product. Be prepared to collect the fluid with suitable containers before opening any compartment or disassembling any component containing fluids.

Dispose of all fluids according to local regulations and mandates.

Asbestos Information

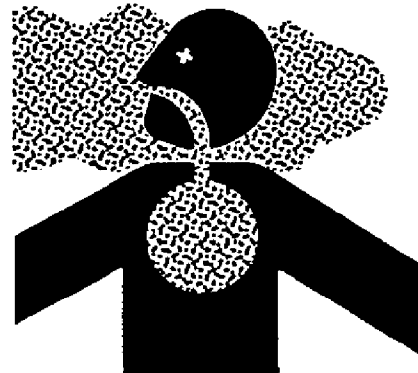

Illustration 7

g00702022

Perkins replacement parts that are shipped from Perkins are asbestos free. Perkins recommends the use of only genuine Perkins replacement parts. Use the following guidelines when you handle any replacement parts that contain asbestos or when you handle asbestos debris.

Use caution. Avoid inhaling dust that might be generated when you handle components that contain asbestos fibers. Inhaling this dust can be hazardous to your health. The components that may contain asbestos fibers are brake pads, brake bands, lining material, clutch plates, and some gaskets. The asbestos that is used in these components is usually bound in a resin or sealed in some way. Normal handling is not hazardous unless airborne dust that contains asbestos is generated.

If dust that may contain asbestos is present, there are several guidelines that should be followed:

- Never use compressed air for cleaning.
- Avoid brushing materials that contain asbestos.
- Avoid grinding materials that contain asbestos.
- Use a wet method in order to clean up asbestos materials.
- A vacuum cleaner that is equipped with a high efficiency particulate air filter (HEPA) can also be used.
- Use exhaust ventilation on permanent machining jobs.
- Wear an approved respirator if there is no other way to control the dust.
- Comply with applicable rules and regulations for the work place. In the United States, use Occupational Safety and Health Administration (OSHA) requirements. These OSHA requirements can be found in "29 CFR 1910.1001".

- Obey environmental regulations for the disposal of asbestos.
- Stay away from areas that might have asbestos particles in the air.

Dispose of Waste Properly

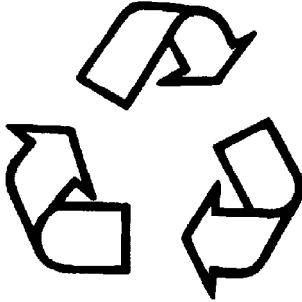

Illustration 8

g00706404

Improperly disposing of waste can threaten the environment. Potentially harmful fluids should be disposed of according to local regulations.

Always use leakproof containers when you drain fluids. Do not pour waste onto the ground, down a drain, or into any source of water.

i04259330

Burn Prevention

Do not touch any part of an operating engine system. Allow the engine system to cool before any maintenance is performed.

Relieve all pressure in the following systems, hydraulic system, lubrication system, fuel system, and the coolant system before the related items are disconnected.

After the engine has stopped, you must wait for 10 minutes in order to allow the pressure to be purged from the high-pressure lines before any service or repair is performed on the engine lines.

Allow the pressure to be purged in the air system, in the hydraulic system, in the lubrication system, or in the cooling system before any lines, fittings, or related items are disconnected.

Induction System

WARNING

Sulfuric Acid Burn Hazard may cause serious personal injury or death.

The exhaust gas cooler may contain a small amount of sulfuric acid. The use of fuel with sulfur levels greater than 15 ppm may increase the amount of sulfuric acid formed. The sulfuric acid may spill from the cooler during service of the engine. The sulfuric acid will burn the eyes, skin and clothing on contact. Always wear the appropriate personal protective equipment (PPE) that is noted on a material safety data sheet (MSDS) for sulfuric acid. Always follow the directions for first aid that are noted on a material safety data sheet (MSDS) for sulfuric acid.

Coolant

When the engine is at operating temperature, the engine coolant is hot. The coolant is also under pressure. The radiator and all lines to the heaters or to the engine contain hot coolant.

Any contact with hot coolant or with steam can cause severe burns. Allow cooling system components to cool before the cooling system is drained.

Check that the coolant level after the engine has stopped and the engine has been allowed to cool.

Ensure that the filler cap is cool before removing the filler cap. The filler cap must be cool enough to touch with a bare hand. Remove the filler cap slowly in order to relieve pressure.

Cooling system conditioner contains alkali. Alkali can cause personal injury. Do not allow alkali to contact the skin, the eyes, or the mouth.

Oils

Hot oil and hot lubricating components can cause personal injury. Do not allow hot oil to contact the skin. Also, do not allow hot components to contact the skin.

Batteries

Electrolyte is an acid. Electrolyte can cause personal injury. Do not allow electrolyte to contact the skin or the eyes. Always wear protective glasses for servicing batteries. Wash hands after touching the batteries and connectors. Use of gloves is recommended.

i04259389

Fire Prevention and Explosion Prevention



Illustration 9

g00704000

All fuels, most lubricants, and some coolant mixtures are flammable.

Flammable fluids that are leaking or spilled onto hot surfaces or onto electrical components can cause a fire. Fire may cause personal injury and property damage.

A flash fire may result if the covers for the engine crankcase are removed within 15 minutes after an emergency shutdown.

Determine whether the engine will be operated in an environment that allows combustible gases to be drawn into the air inlet system. These gases could cause the engine to overspeed. Personal injury, property damage, or engine damage could result.

If the application involves the presence of combustible gases, consult your Perkins dealer and/or your Perkins distributor for additional information about suitable protection devices.

Remove all flammable combustible materials or conductive materials such as fuel, oil, and debris from the engine. Do not allow any flammable combustible materials or conductive materials to accumulate on the engine.

Store fuels and lubricants in correctly marked containers away from unauthorized persons. Store oily rags and any flammable materials in protective containers. Do not smoke in areas that are used for storing flammable materials.

Do not expose the engine to any flame.

Exhaust shields (if equipped) protect hot exhaust components from oil or fuel spray in case of a line, a tube, or a seal failure. Exhaust shields must be installed correctly.

Do not weld on lines or tanks that contain flammable fluids. Do not flame cut lines or tanks that contain flammable fluid. Clean any such lines or tanks thoroughly with a nonflammable solvent prior to welding or flame cutting.

Wiring must be kept in good condition. All electrical wires must be correctly routed and securely attached. Check all electrical wires daily. Repair any wires that are loose or frayed before you operate the engine. Clean all electrical connections and tighten all electrical connections.

Eliminate all wiring that is unattached or unnecessary. Do not use any wires or cables that are smaller than the recommended gauge. Do not bypass any fuses and/or circuit breakers.

Arcing or sparking could cause a fire. Secure connections, recommended wiring, and correctly maintained battery cables will help to prevent arcing or sparking.

Inspect all lines and hoses for wear or for deterioration. The hoses must be correctly routed. The lines and hoses must have adequate support and secure clamps. Tighten all connections to the recommended torque. Leaks can cause fires.

Oil filters and fuel filters must be correctly installed. The filter housings must be tightened to the correct torque.



Illustration 10

g00704059

Use caution when you are refueling an engine. Do not smoke while you are refueling an engine. Do not refuel an engine near open flames or sparks. Always stop the engine before refueling.

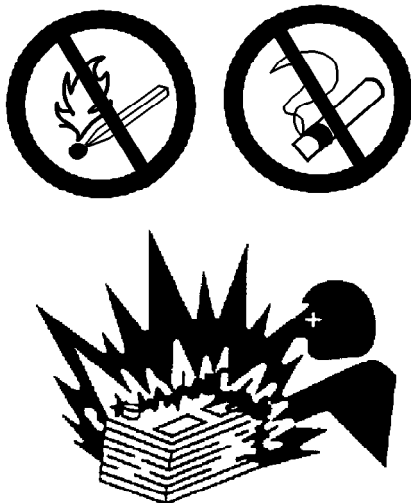

Illustration 11

g00704135

Gases from a battery can explode. Keep any open flames or sparks away from the top of a battery. Do not smoke in battery charging areas.

Never check the battery charge by placing a metal object across the terminal posts. Use a voltmeter or a hydrometer.

Incorrect jumper cable connections can cause an explosion that can result in injury. Refer to the Operation Section of this manual for specific instructions.

Do not charge a frozen battery. This may cause an explosion.

The batteries must be kept clean. The covers (if equipped) must be kept on the cells. Use the recommended cables, connections, and battery box covers when the engine is operated.

Fire Extinguisher

Make sure that a fire extinguisher is available. Be familiar with the operation of the fire extinguisher. Inspect the fire extinguisher and service the fire extinguisher regularly. Obey the recommendations on the instruction plate.

Lines, Tubes, and Hoses

Do not bend high-pressure lines. Do not strike high-pressure lines. Do not install any lines that are bent or damaged. Do not clip any other items to the high-pressure lines.

Repair any lines that are loose or damaged. Leaks can cause fires. Consult your Perkins dealer or your Perkins distributor for repair or for replacement parts.

Check lines, tubes, and hoses carefully. Do not use your bare hand to check for leaks. Use a board or cardboard to check for leaks. Tighten all connections to the recommended torque.

Replace the parts if any of the following conditions are present:

- End fittings are damaged or leaking.
- Outer coverings are chafed or cut.
- Wires are exposed.
- Outer coverings are ballooning.
- Flexible parts of the hoses are kinked.
- Outer covers have embedded armoring.
- End fittings are displaced.

Make sure that all clamps, guards, and heat shields are installed correctly. During engine operation, this will help to prevent vibration, rubbing against other parts, and excessive heat.

High-pressure oil within the high-pressure oil line is used in order to create high-pressure fuel in the unit injectors.

i02143194

Crushing Prevention and Cutting Prevention

Support the component correctly when work beneath the component is performed.

Unless other maintenance instructions are provided, never attempt adjustments while the engine is running.

Stay clear of all rotating parts and of all moving parts. Leave the guards in place until maintenance is performed. After the maintenance is performed, reinstall the guards.

Keep objects away from moving fan blades. The fan blades will throw objects or cut objects.

When objects are struck, wear protective glasses in order to avoid injury to the eyes.

Chips or other debris may fly off objects when objects are struck. Before objects are struck, ensure that no one will be injured by flying debris.

i05768982

Mounting and Dismounting

Do not climb on the engine or the engine aftertreatment system. The engine and aftertreatment system have not been designed with mounting or dismounting locations.

Refer to the OEM for the location of foot and hand holds for your specific application.

i04553464

High Pressure Oil Lines

 **WARNING**

Personal injury can result from oil under high pressure.

DO NOT allow high pressure oil to contact skin.

Wear appropriate protective equipment while working with high pressure oil systems.

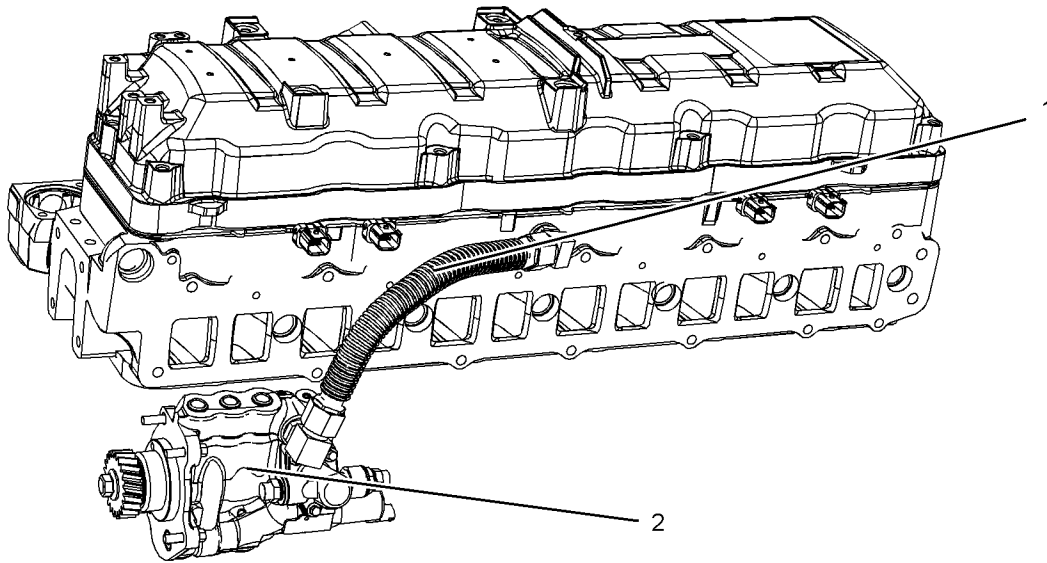

Illustration 12

g02722895

(1) High-pressure oil line

(2) High-pressure oil pump

The high-pressure oil line is the line that is between the high-pressure oil pump and the high-pressure oil manifold within the cylinder head. This high-pressure line is different from fuel lines on other fuel systems.

These differences are because of the following items:

- The high-pressure oil line is constantly charged with high pressure.
- The internal pressure of the high-pressure oil line is higher than other types of fuel systems.

Do not step on the high-pressure oil line. Do not deflect the high-pressure oil line. Do not bend or strike the high-pressure oil line. Deformation or damage of the high-pressure oil line may cause a point of weakness and potential failure.

Do not check the high-pressure oil line with the engine or the starting motor in operation. After the engine has stopped, wait 10 minutes in order to allow the pressure to be purged from the high-pressure oil line, before any service or repair is performed.

Visually inspect the high-pressure oil line before the engine is started. This inspection should be each day.

If you inspect the engine in operation, always use the proper inspection procedure in order to avoid a fluid penetration hazard. Refer to Operation and Maintenance Manual, "General hazard Information".

- Inspect the high-pressure oil line for damage, deformation, a nick, a cut, a crease, or a dent.

- Do not operate the engine with a leak. Refer to Disassembly and Assembly, "High-Pressure Oil Line- Remove and Install".
- If the high-pressure oil line is torqued correctly, and the high-pressure oil line is leaking the high-pressure oil line must be replaced.
- Do not attach any other item to the high-pressure oil line.

i05874054

Before Starting Engine

NOTICE

For initial start-up of a new or rebuilt engine, and for start-up of an engine that has been serviced, make provision to shut the engine off should an overspeed occur. This may be accomplished by shutting off the air and/or fuel supply to the engine.

WARNING

Engine exhaust contains products of combustion which may be harmful to your health. Always start and operate the engine in a well ventilated area and, if in an enclosed area, vent the exhaust to the outside.

Inspect the engine for potential hazards.

Do not start the engine or move any of the controls if there is a "DO NOT OPERATE" warning tag or similar warning tag attached to the start switch or to the controls.

Before starting the engine, ensure that no one is on, underneath, or close to the engine. Ensure that the area is free of personnel.

If equipped, ensure that the lighting system for the engine is suitable for the conditions. Ensure that all lights work properly, if equipped.

All protective guards and all protective covers must be installed if the engine must be started in order to perform service procedures. To help prevent an accident that is caused by parts in rotation, work around the parts carefully.

Do not bypass the automatic shutoff circuits. Do not disable the automatic shutoff circuits. The circuits are provided in order to help prevent personal injury. The circuits are also provided in order to help prevent engine damage.

See the Service Manual for repairs and for adjustments.

i07828827

Engine Starting

S/N: XGA1–Up

S/N: XGB1–Up

S/N: XGD1–Up

S/N: XGF1–Up

S/N: XGH1–Up

WARNING

Do not use aerosol types of starting aids such as ether. Such use could result in an explosion and personal injury.

WARNING

Engine exhaust contains products of combustion which may be harmful to your health. Always start and operate the engine in a well ventilated area and, if in an enclosed area, vent the exhaust to the outside.

If a warning tag is attached to the engine start switch or to the controls, DO NOT start the engine or move the controls. Consult with the person that attached the warning tag before the engine is started.

All protective guards and all protective covers must be installed if the engine must be started to perform service procedures. To help prevent an accident that is caused by parts in rotation, work around the parts carefully.

Start the engine from the operator's compartment or from the engine start switch.

Always start the engine according to the procedure that is described in the Operation and Maintenance Manual, "Engine Starting" topic in the Operation Section. Knowing the correct procedure will help to prevent major damage to the engine components. Knowing the procedure will also help to prevent personal injury.

To ensure that the jacket water heater (if equipped) is working correctly, check the water temperature gauge and/or the oil temperature gauge during the heater operation.

Note: The engine may be equipped with a device for cold starting. If the engine will be operated in very cold conditions, then an extra cold starting aid may be required. Normally, the engine will be equipped with the correct type of starting aid for your region of operation.

i02234873

Engine Stopping

Stop the engine according to the procedure in the Operation and Maintenance Manual, "Engine Stopping (Operation Section)" in order to avoid overheating of the engine and accelerated wear of the engine components.

Use the Emergency Stop Button (if equipped) ONLY in an emergency situation. Do not use the Emergency Stop Button for normal engine stopping. After an emergency stop, DO NOT start the engine until the problem that caused the emergency stop has been corrected.

Stop the engine if an overspeed condition occurs during the initial start-up of a new engine or an engine that has been overhauled.

To stop an electronically controlled engine, cut the power to the engine and/or shutting off the air supply to the engine.

i04259711

Electrical System

Never disconnect any charging unit circuit or battery circuit cable from the battery when the charging unit is operating. A spark can cause the combustible gases that are produced by some batteries to ignite.

To help prevent sparks from igniting combustible gases that are produced by some batteries, the negative “-” cable should be connected last from the external power source to the primary position for grounding.

Check the electrical wires daily for wires that are loose or frayed. Tighten all loose electrical connections before the engine is started. Repair all frayed electrical wires before the engine is started. See the Operation and Maintenance Manual for specific starting instructions.

Grounding Practices

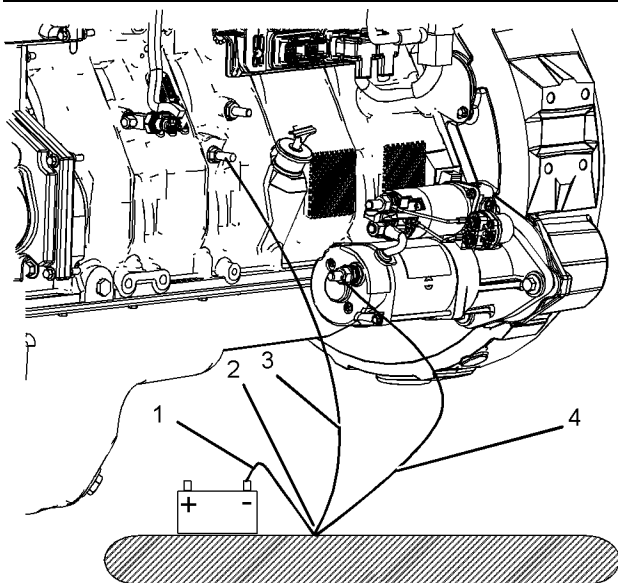

Illustration 13

g02430157

Typical example

- (1) Ground to battery
- (2) Primary position for grounding
- (3) Ground to engine block
- (4) Ground to starting motor

Correct grounding for the engine electrical system is necessary for optimum engine performance and reliability. Incorrect grounding will result in uncontrolled electrical circuit paths and in unreliable electrical circuit paths.

Uncontrolled electrical circuit paths can result in damage to the crankshaft bearing journal surfaces and to aluminum components.

Engines that are installed without engine-to-frame ground straps can be damaged by electrical discharge.

To ensure that the engine and the engine electrical systems function correctly, an engine-to-frame ground strap with a direct path to the battery must be used. This path may be provided by way of a direct engine ground to the frame.

The connections for the grounds should be tight and free of corrosion. The engine alternator must be grounded to the negative “-” battery terminal with a wire that is adequate to handle the full charging current of the alternator.

The power supply connections and the ground connections for the engine electronics should always be from the isolator to the battery.

i04259752

Engine Electronics

WARNING

Tampering with the electronic system installation or the OEM wiring installation can be dangerous and could result in personal injury or death and/or engine damage.

This engine has a comprehensive, programmable Engine Monitoring System. The Engine Control Module (ECM) has the ability to monitor the engine operating conditions. If any of the engine parameters extend outside an allowable range, the ECM will initiate an immediate action.

The following actions are available for engine monitoring control: WARNING, ACTION ALERT and SHUTDOWN.

Many of the parameters that are monitored by the ECM can be programmed for the engine monitoring functions. The following parameters can be monitored as a part of the Engine Monitoring System:

- Intake Manifold Air Pressure
- Intake Manifold Temperature
- Coolant Temperature
- Engine Oil Pressure
- Engine Oil Temperature
- Crankshaft Position
- Camshaft Position
- Fuel Pressure

- System Voltage

The Engine Monitoring package can vary for different engine models and different engine applications. However, the monitoring system and the engine monitoring control will be similar for all engines.

Product Information Section

General Information

i04260031

Model View Illustrations

1600D Engine

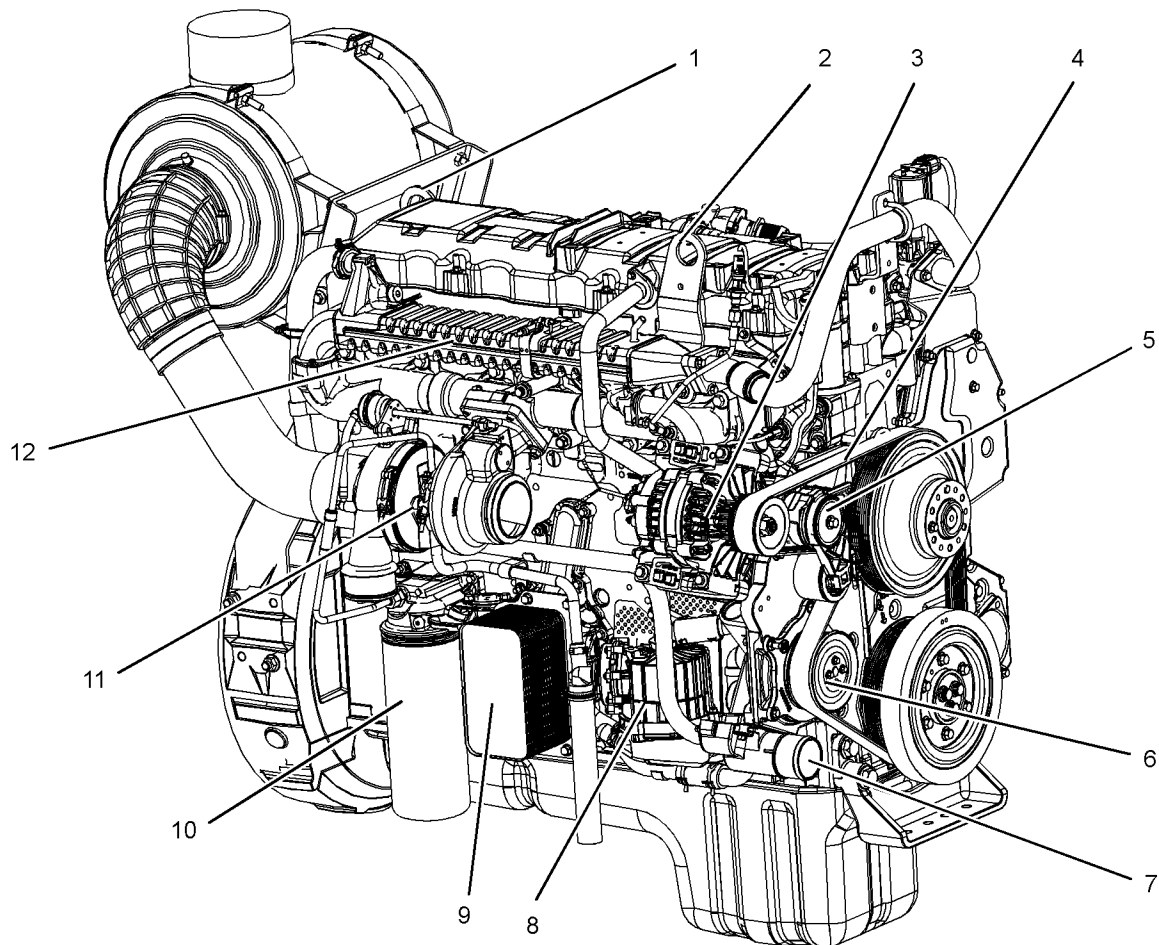

Illustration 14

g02757356

- (1) Rear lifting eye
- (2) Front lifting eye
- (3) Alternator
- (4) Drive belt

- (5) Belt tensioner
- (6) Coolant pump
- (7) Coolant intake connection
- (8) Crankcase breather

- (9) Oil cooler
- (10) Oil filter
- (11) Turbocharger
- (12) NOx Reduction cooler

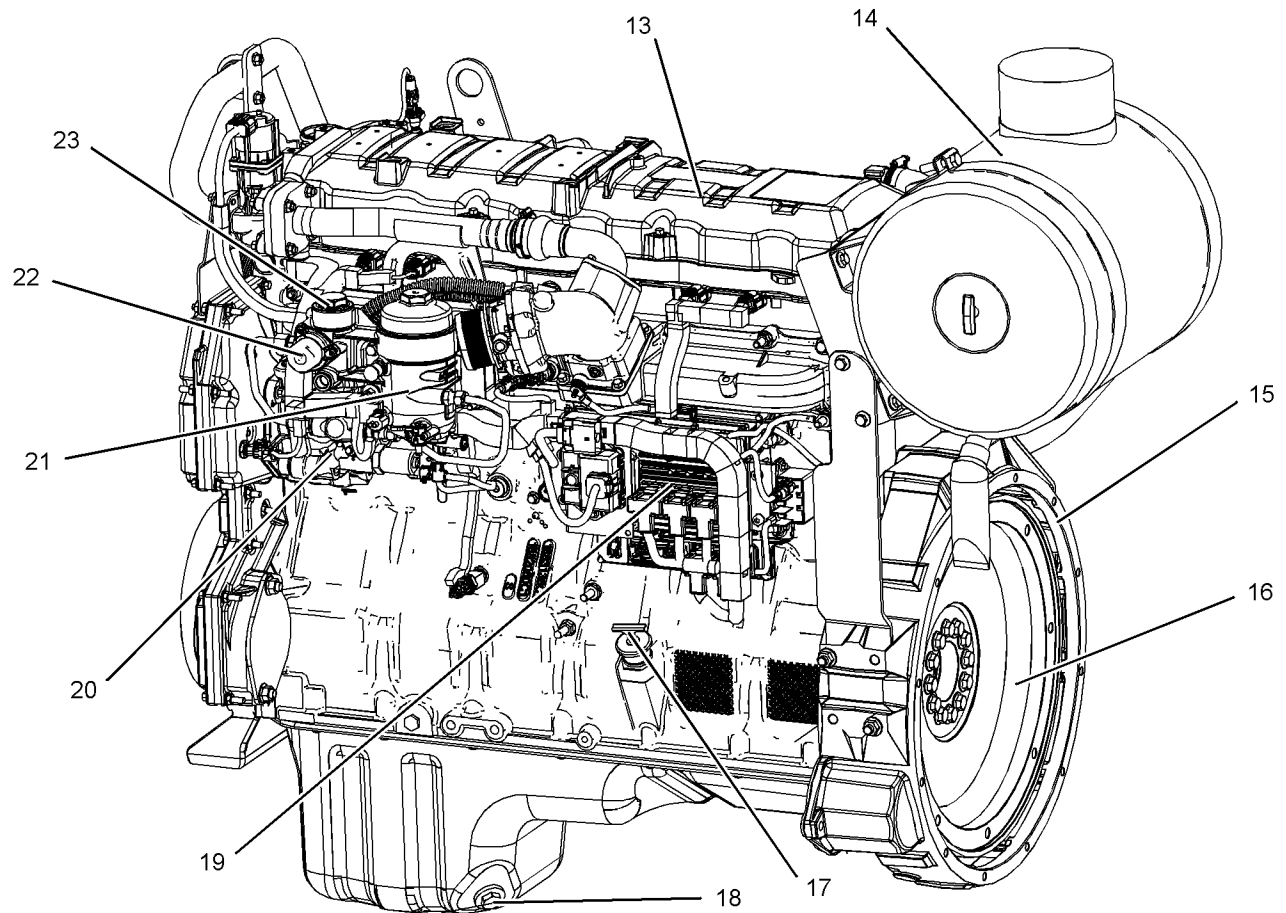

Illustration 15

g02430477

(13) Valve mechanism cover
 (14) Air cleaner
 (15) Flywheel housing
 (16) Flywheel

(17) Oil filler
 (18) Oil drain plug
 (19) Control module
 (20) High-pressure oil pump

(21) Secondary fuel filter
 (22) Hand prime pump
 (23) Primary fuel filter

Coolant System for 1600D Engine

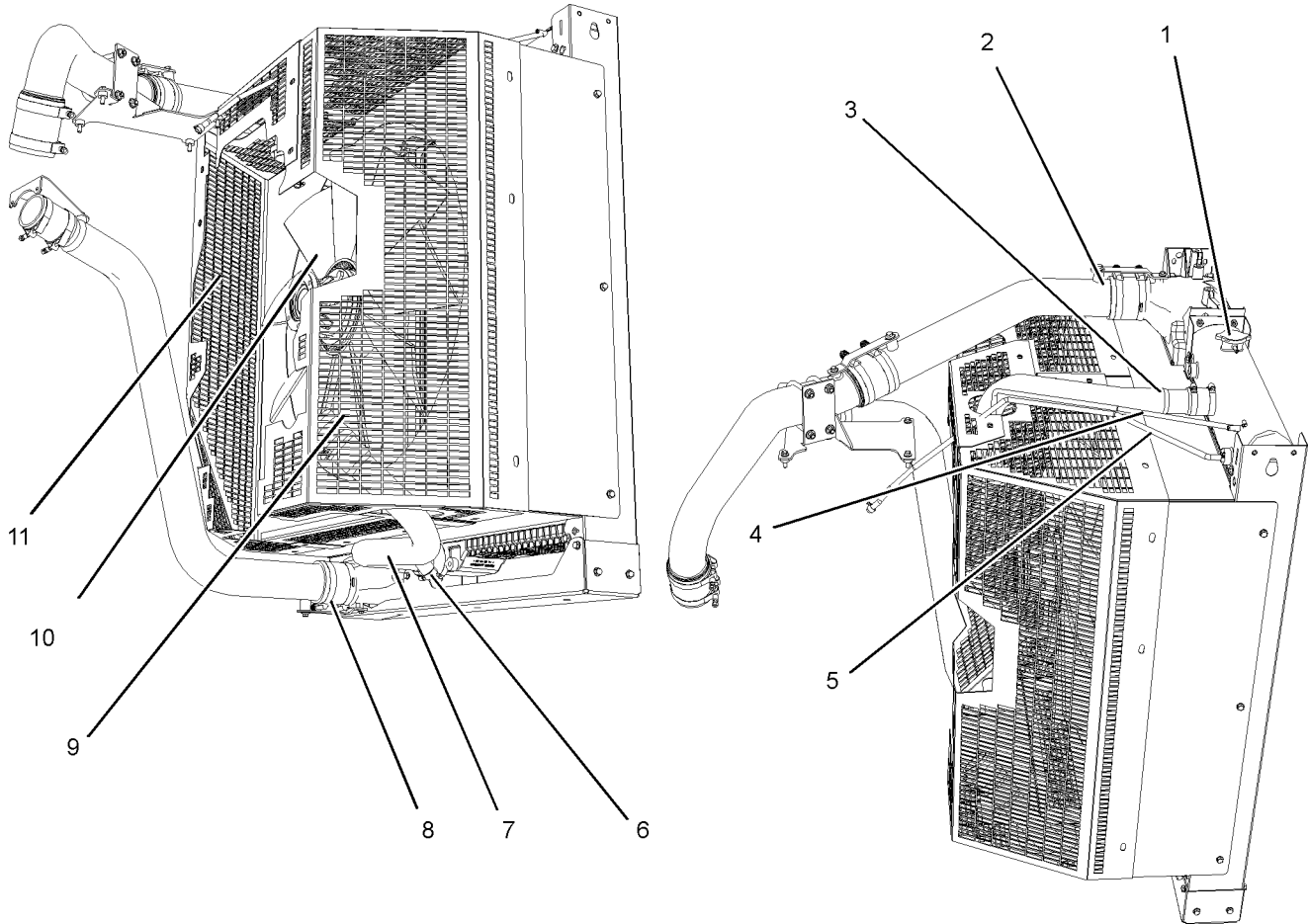

Illustration 16

g02430617

- (1) Radiator filler cap
- (2) Air to air charge cooler connection
- (3) Coolant inlet connection
- (4) Front vent line

- (5) Rear vent liner
- (6) Coolant drain plug
- (7) Coolant outlet connection
- (8) Air to air charge cooler connection

- (9) Fan guard
- (10) Fan
- (11) Fan guard

1600A Engine

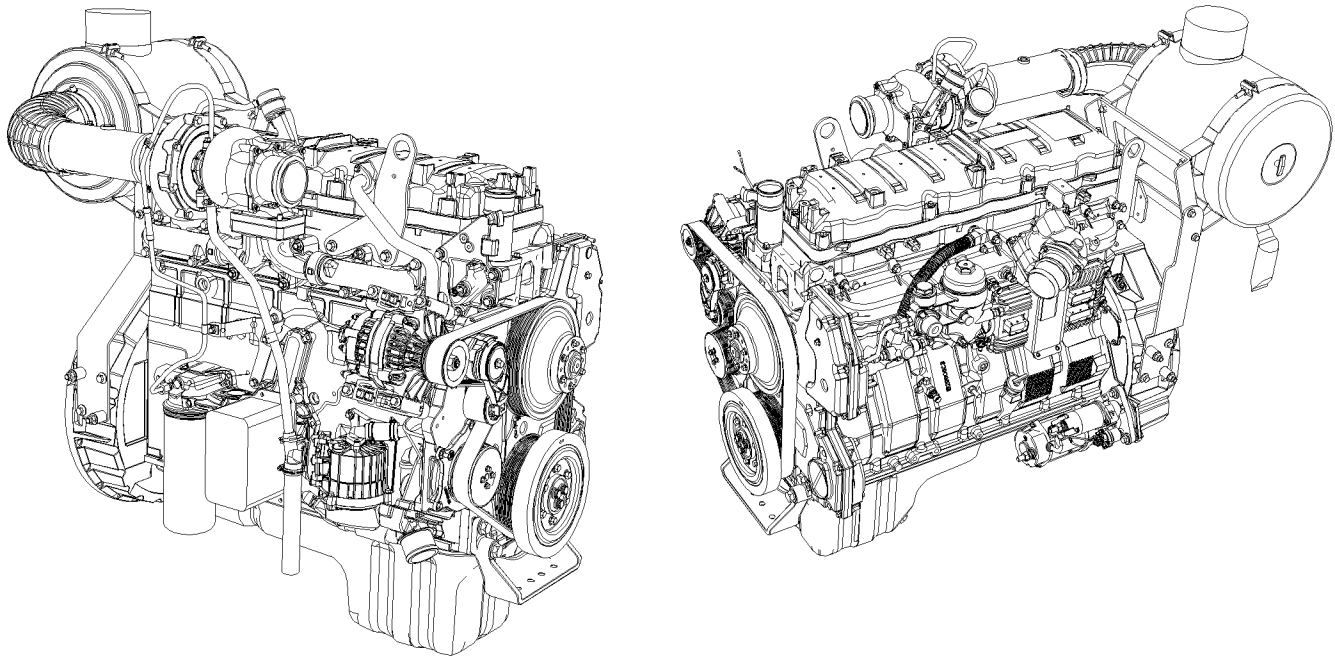

Illustration 17

Typical example

g02794993

i04261592

The 1606D engines will have NOx Reduction System (NRS) installed.

Product Description

The Perkins 1600 Series Industrial Engines has the following characteristics.

- In-line Six cylinder
- Four stroke cycle
- Turbocharged charge cooled

The 1600 series engines can be divided into two different engine groups. The 1606A LBSFC unregulated engine and the 1606D EU stage 3A compliant engine.

Engine Specifications

Note: The front end of the engine is opposite the flywheel end of the engine. The left and the right sides of the engine are determined from the flywheel end. The number 1 cylinder is the front cylinder.

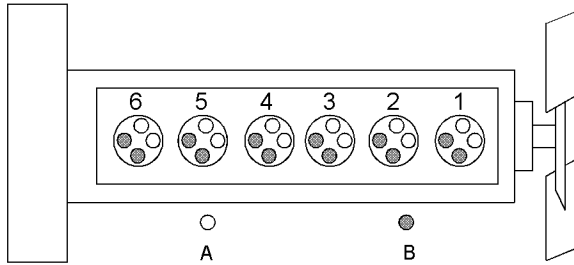

Illustration 18

g02433836

Cylinder and valve location

- (A) Inlet valves
(B) Exhaust valves

Table 1

1600 Series Engine Specifications	
Operating Range (rpm)	1500 to 1800 ⁽¹⁾
Number of Cylinders	6 In-Line
Bore	116.6 mm sleeve diameter
Stroke	146
Power	298 to 315 kW (400 to 422 hp) ⁽²⁾
Aspiration	Turbocharged charge cooled
Compression Ratio	17.2 to 1
Displacement	9.3 L
Firing Order	1-5-3-6-2-4
Rotation (flywheel end)	Counterclockwise

⁽¹⁾ Depending upon application.

⁽²⁾ Gross power

The crankshaft has a seven main bearing journals, a fractured split connecting rods is connected to each crankshaft journal. The pistons have an off set axis and made from a one piece steel construction. The cylinder block has wet liners with a single seal. Four bushing support the camshaft, and the camshaft is driven by a drive gear. The camshaft operates the over head valves. Each cylinder has two inlet valves and, two exhaust valves.

The engine lubricating oil is supplied by a gerotor oil pump. The engine has an oil cooler and a spin on oil filter.

The diesel fuel is drawn from the fuel tank into a strainer and into a fuel pump. The fuel pump sends the fuel into the main fuel filter. From the main fuel filter the fuel is sent internally to the fuel injectors by means of an internal fuel manifold. The fuel injectors use engine lubricating oil from a high-pressure pump in order to increase the injection pressure. The injectors are controlled by the engine electronic control module (ECM).

Aftermarket Products and Perkins Engines

Perkins does not warrant the quality or performance of non-Perkins fluids and filters.

When auxiliary devices, accessories, or consumables (filters, additives, catalysts,) which are made by other manufacturers are used on Perkins products, the Perkins warranty is not affected simply because of such use.

However, failures that result from the installation or use of other manufacturers devices, accessories, or consumables are NOT Perkins defects. Therefore, the defects are NOT covered under the Perkins warranty.

Product Identification Information

i04266129

Plate Locations and Film Locations

Perkins engines are identified by serial numbers. These numbers are shown on the engine serial number plate. Perkins distributors need these numbers in order to determine the components that were included with the engine. This information permits accurate identification of replacement part numbers.

Engine Identification

Perkins engines are identified by an engine serial number.

A typical example of an engine serial number is XGE F**** U00001W.

X _____ Made in Stafford
 G _____ Application (Table 2)
 E _____ Type of engine (Table 3)
 F _____ Number of cylinders (Table 4)
 ***** _____ Fixed build number
 N _____ Built in the USA
 00001 _____ Engine Number
 W _____ Year of Manufacture

Table 2

Application	
G	Genset

Table 3

Type of engine (Diesel)	
A	TAG1
B	TAG2
D	TAG3
E	TAG4
F	TAG5
H	TAG6

Table 4

Number of Cylinders	
F	6
H	8
M	12
R	16

Perkins dealers and Perkins distributors require all of these numbers in order to determine the components that were included in the engine. This information permits accurate identification of replacement part numbers.

Serial Number Plate (1)

Perkins Engine Company LTD. England	
	
Engine No.	<input type="text"/>
Designation.	<input type="text"/>
Engine Rating.	<input type="text"/>
For spares quote Engine No.	

Illustration 19

g02435523

Typical example

The engine serial number plate is located on right side of the cylinder block above the engine oil filter.

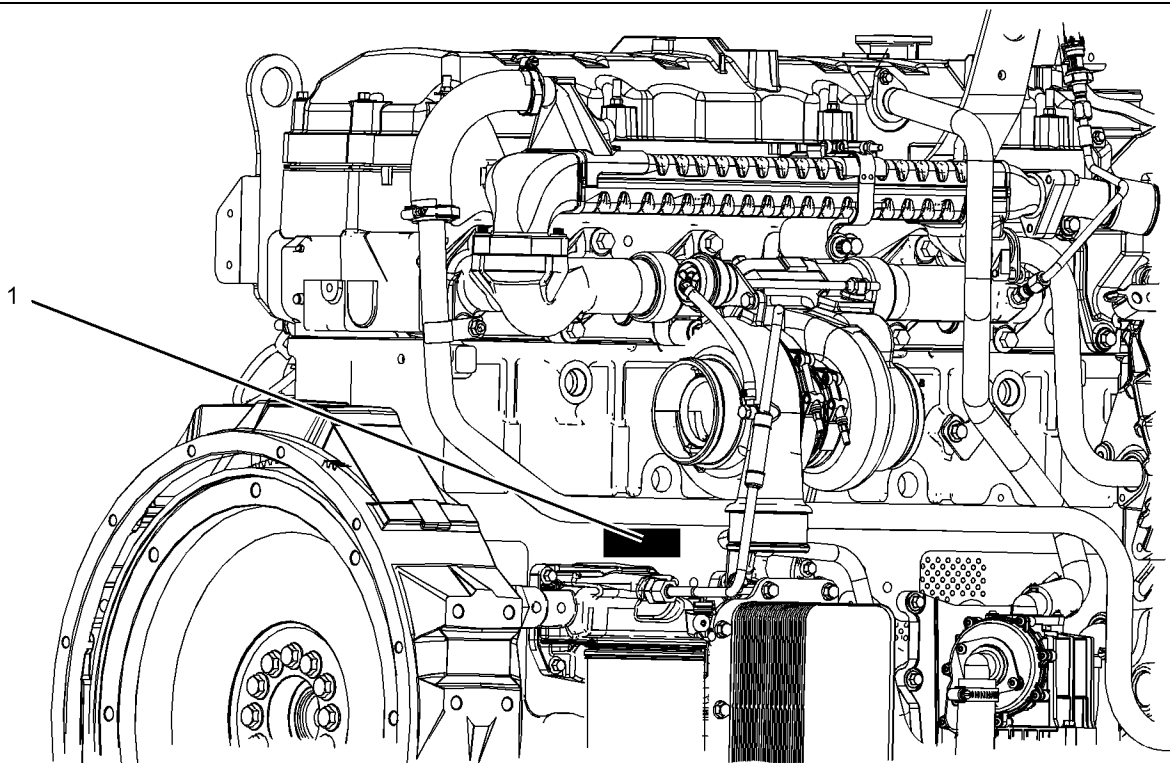

Illustration 20

g02435519

Typical example

i04266330

Emissions Certification Film

The emission label for the 1600D engine is installed on rear of the valve mechanism cover.

IMPORTANT ENGINE INFORMATION		
ENGINE FAMILY: #####	Initial Injector Timing: Electronic	
Engine Type: #####	Displacement: 9.3 Litres	
Emissions Control System: ####		
Valve Lash Cold Inlet - ## Exhaust - ##		
<p style="text-align: center;">This engine conforms to EU 97/68/EC directive for large non road and off-road compression ignition engines, constant speed only. This engine is certified to operate on commercially available diesel fuel.</p>		
		Part No. #####

Illustration 21

g02435679

Typical example

The emission label for the 1600A engine is installed on rear of the valve mechanism cover.

EMISSION CONTROL INFORMATION	
INFORMATION APPLICABLE TO USA ONLY	
THIS ENGINE IS SOLELY FOR EXPORT AND IS THEREFORE EXEMPT UNDER 40 CFR 1068.230 FROM U.S. EMISSIONS STANDARDS AND RELATED REQUIREMENTS.	
Part No. #####	

Illustration 22

g02834955

i04266250

Reference Information

Information for the following items may be needed to order parts. Locate the information for your engine. Record the information in the appropriate space. Make a copy of this list for a record. Keep the information for future reference.

Record for Reference

Engine Model _____

Engine Serial number _____

Engine rpm _____

Fuel Strainer _____

Fuel Filter Element _____

Lubrication Oil Filter _____

Total Lubrication System Capacity _____

Total Cooling System Capacity _____

Air Cleaner Element _____

Drive Belt _____

Operation Section

i04823376

Lifting and Storage

i07444656

Product Lifting

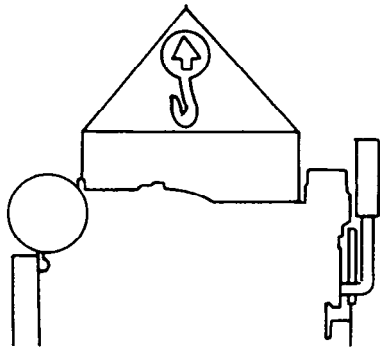

Illustration 23

g00103219

NOTICE

Always inspect lifting eyebolts and all other lifting equipment for damage before performing any lifting. Never bend the eyebolts and the brackets. Never perform product lifting if components are damaged. Only load the eyebolts and the brackets under tension. Remember that the capacity of an eyebolt is less as the angle between the supporting members and the object becomes less than 90 degrees.

Use a hoist to remove heavy components. Use an adjustable lifting beam to lift the engine. All supporting members (chains and cables) should be parallel to each other. The chains and cables should be perpendicular to the top of the object that is being lifted.

Some removals require lifting the fixtures to obtain proper balance and safety.

To remove the engine ONLY, use the lifting eyes that are on the engine.

Lifting eyes are designed and installed for specific engine arrangements. Alterations to the lifting eyes and/or the engine make the lifting eyes and the lifting fixtures obsolete. If alterations are made, ensure that proper lifting devices are provided. Consult your Perkins dealer for information regarding fixtures for proper engine lifting.

Product Storage

Refer to Perkins Engine Company limited, Stafford for information on engine storage.

There are three different levels of engine storage. Level "A, B and C" .

Level "A "

Level "A" will give protection for 12 month for diesel engines and 12 month protection for gas engines. This level is for engines that are transported by a container or a truck. Level "A" is for the transportation of items that are within the United kingdom and within Europe.

Level "B "

This level is additional to level "A" . Level "B" will give protection under normal storage condition from -15° to $+55^{\circ}\text{C}$ (5° to 99°F) and "90%" relative humidity for 2 year. Level "B" is for the transportation of items overseas.

Level "C "

In order to protect the product to Level "C" , contact Perkins Engines Company Limited Stafford.

Features and Controls

i04266770

i04266369

Alarms and Shutoffs

Engine Shutoffs

The shutoffs are electrically operated or mechanically operated. The electrically operated shutoffs are controlled by the ECM.

Shutoffs are set at critical levels for the following items:

- Operating temperature
- Operating pressure
- Operating level

The particular shutoff may need to be reset before the engine will start.

NOTICE

Always determine the cause of the engine shutdown. Make necessary repairs before attempting to restart the engine.

Be familiar with the following items:

- Types and locations of the shutoff
- Conditions which cause each shutoff to function
- The resetting procedure that is required to restart the engine

Engine Alarms

The alarms are electrically operated. The operation of the alarms is controlled by the ECM.

The alarm is operated by a sensor or by a switch. When the sensor or the switch is activated, a signal is sent to the ECM. An event code is created by the ECM. The ECM will send a signal in order to illuminate the lamp.

Your engine may be equipped with the following sensors or switches:

- Engine oil temperature sensor
- Engine oil pressure sensor

- Engine coolant temperature sensor

Gauges and Indicators

Your engine may not have the same gauges or all of the gauges that are described. For more information about the gauge package, see the OEM information.

Gauges provide indications of engine performance. Ensure that the gauges are in good working order. Determine the normal operating range by observing the gauges over a period of time.

Noticeable changes in gauge readings indicate potential gauge or engine problems. Problems may also be indicated by gauge readings that change even if the readings are within specifications. Determine and correct the cause of any significant change in the readings. Consult your Perkins distributor for assistance.

NOTICE

If no oil pressure is indicated, STOP the engine. If maximum coolant temperature is exceeded, STOP the engine. Engine damage can result.



Engine Oil Pressure – The engine oil pressure at idle is 103 kPa (15 psi).

- The 1600A oil pressure at full load can range between 340 to 360 kPa (49 to 52 psi)
- The 1600D oil pressure at full load operates at 370 kPa (53 psi)



Jacket Water Coolant Temperature – Typical water temperature into the engine is 88° to 109°C (190° to 228°F).

Higher temperatures may occur under certain conditions. The water temperature reading may vary according to load. The reading should never exceed 109° C (228° F).

1. A high water temperature switch is installed in the cooling system.



Tachometer – This gauge indicates engine speed (rpm).



Ammeter – This gauge indicates the amount of charge or discharge in the battery charging circuit. Operation of the indicator should be to the right side of “0” (zero).



Service Hour Meter – The gauge indicates operating hours of the engine.

i04266490

Monitoring System

WARNING

If the Shutdown mode has been selected and the warning indicator activates, engine shutdown may take as little as 20 seconds from the time the warning indicator is activated. Depending on the application, special precautions should be taken to avoid personal injury. The engine can be restarted following shutdown for emergency maneuvers, if necessary.

NOTICE

The Engine Monitoring System is not a guarantee against catastrophic failures. Programmed delays and derate schedules are designed to minimize false alarms and provide time for the operator to stop the engine.

The following parameters are monitored:

- Coolant temperature
- Intake manifold air temperature
- Intake manifold air pressure
- Oil pressure
- Oil temperature
- Fuel pressure
- Engine speed/timing
- Fuel temperature
- Atmospheric pressure (Barometric pressure)
- Injection control pressure
- Water in fuel switch

Programmable Options and Systems Operation

WARNING

If the Warning/Derate/Shutdown mode has been selected and the warning indicator activates, bring the engine to a stop whenever possible. Depending on the application, special precautions should be taken to avoid personal injury.

The engine can be programmed to the following modes:

“Warning”

The orange “Warning” lamp will turn “ON” and the warning signal is activated continuously in order to alert the operator that one or more of the engine parameters is not within normal operating range.

“Derate”

The engine will be derated if the engine exceeds preset operational limits. The engine derate is achieved by restricting the amount of fuel that is available for each injection. The amount of this reduction of fuel is dependent on the severity of the fault that has caused the engine derate, typically up to a limit of 50%. This reduction in fuel results in a predetermined reduction in engine power.

“Shutdown”

The orange warning will turn “ON” and the red shutdown lamp will also turn “ON” .

A shutdown of the engine may occur in as little as 3 seconds. The engine can be restarted after a shutdown for use in an emergency. However, the cause of the initial shutdown may still exist. The engine may shut down again in as little as 3 seconds.

For more information or assistance for repairs, consult your Perkins distributor or your Perkins dealer.

i04266532

Sensors and Electrical Components

The illustrations within the section show the typical location of the sensors. Specific engines may appear different from the illustration due to differences in applications.

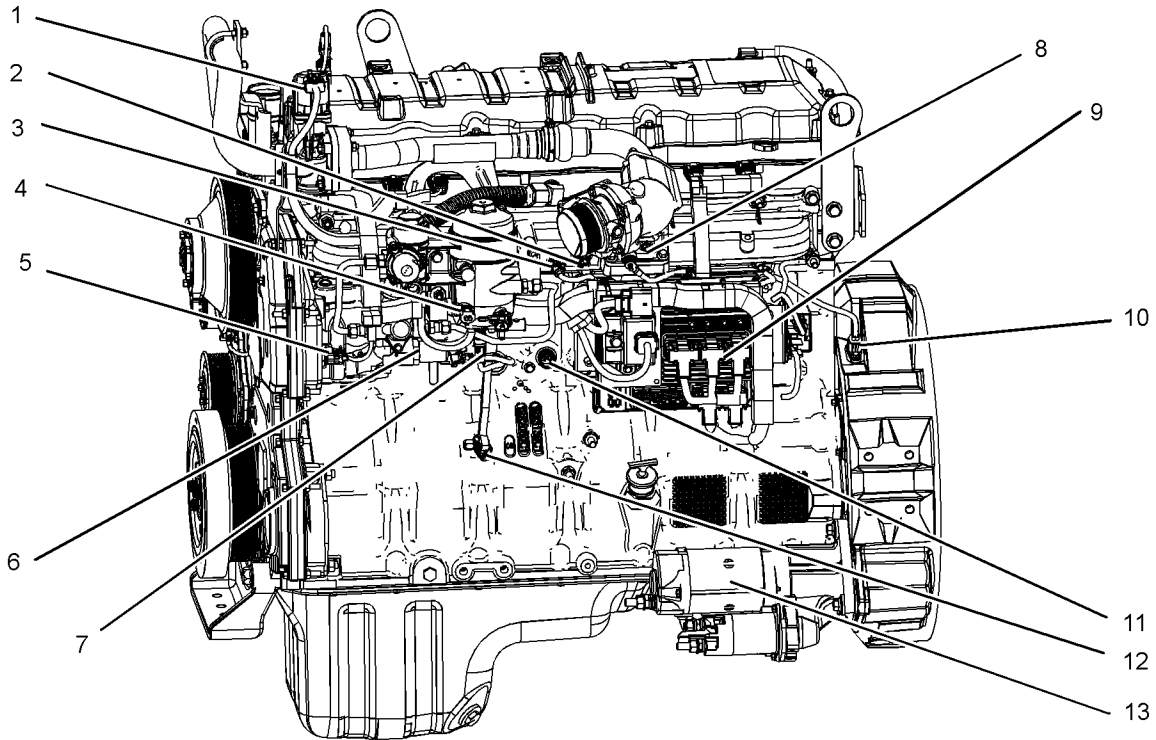

Illustration 24

g02435937

- (1) Valve for the NOx Reduction System (NRS)
- (2) Manifold absolute pressure sensor
- (3) Manifold air temperature sensor
- (4) Water in fuel sensor

- (5) Engine oil temperature sensor
- (6) Injection pressure regulator
- (7) Engine fuel pressure sensor
- (8) Air inlet heater
- (9) Control Module

- (10) Crankshaft position sensor
- (11) Coolant jacket heater
- (12) Engine oil pressure sensor
- (13) Starting motor

Operation Section
Sensors and Electrical Components

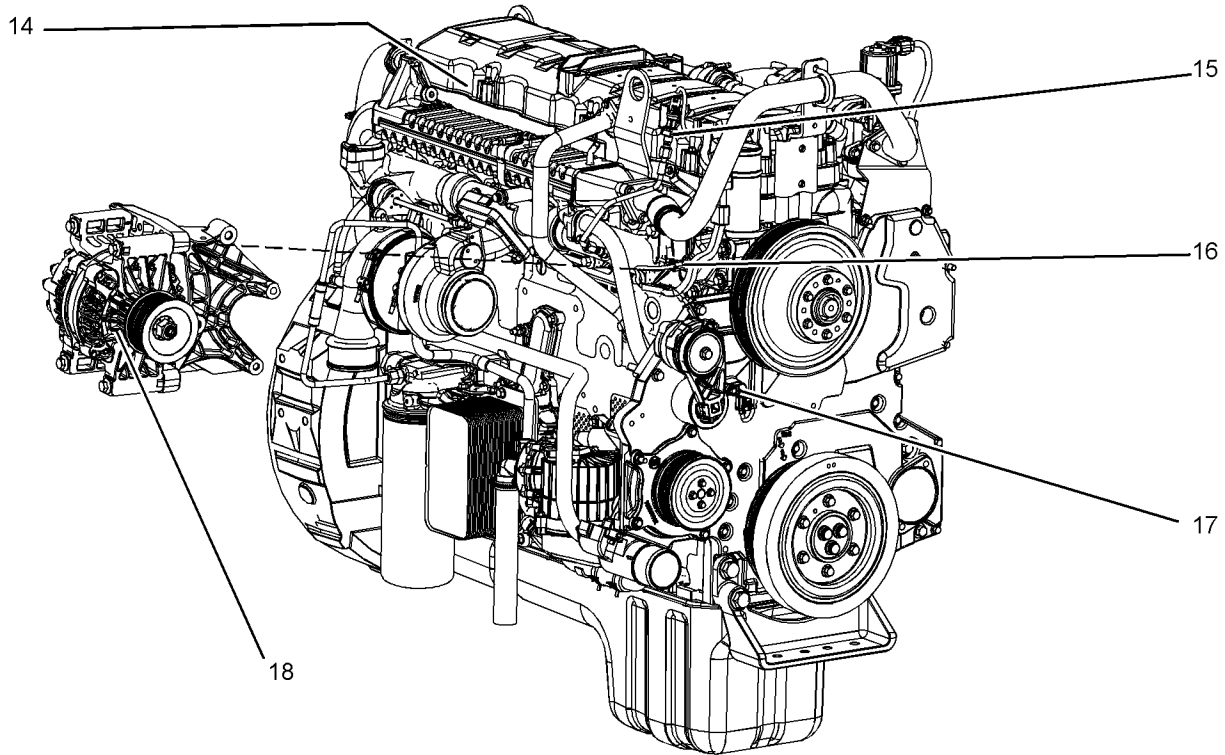

Illustration 25

g02731387

(14) Injection control pressure sensor
(Internal)

(15) Exhaust back pressure sensor
(16) Engine coolant temperature sensor

(17) Camshaft position sensor
(18) Alternator

Alternator has been shown separately for clarity.

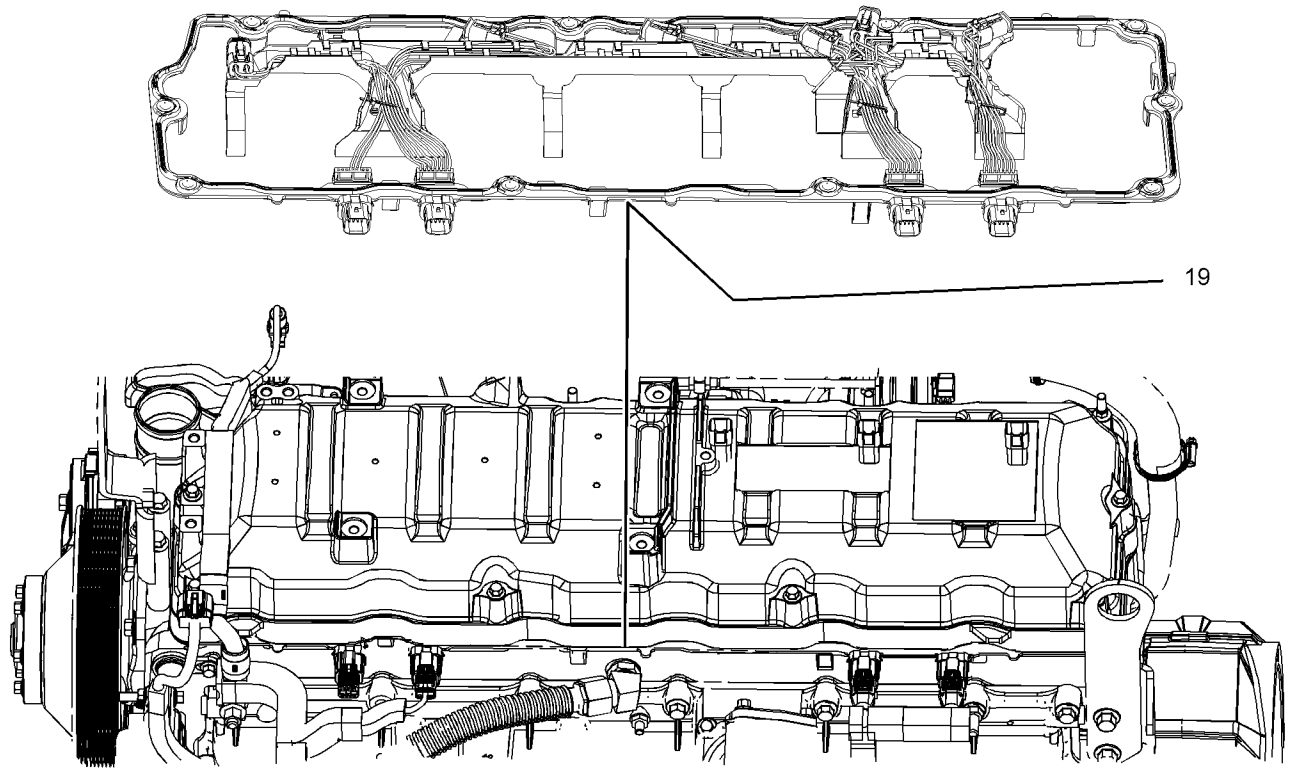

Illustration 26

g02740697

(19) Connector and seal

Operation Section
Sensors and Electrical Components

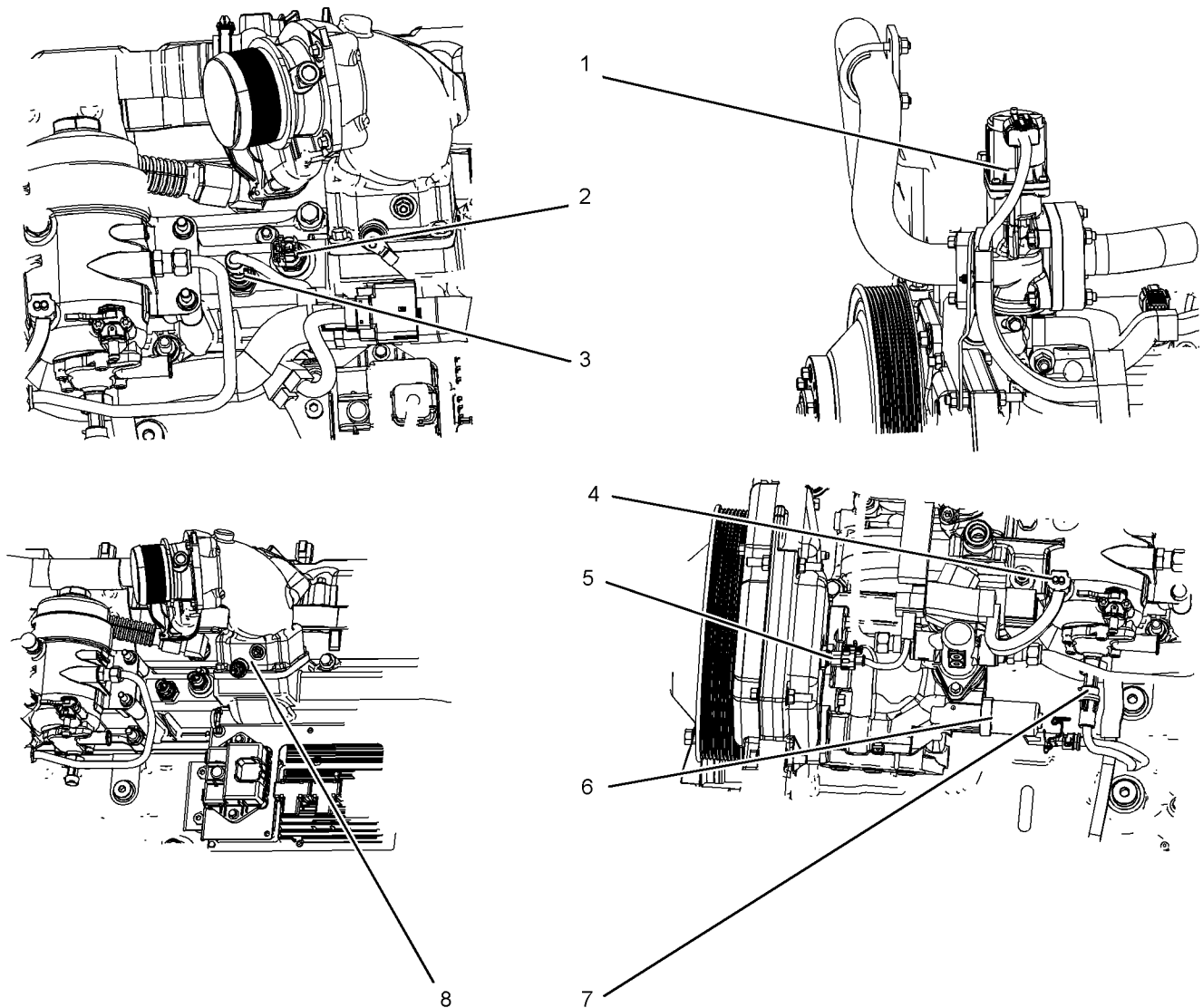

Illustration 27

g02732035

- (1) Valve for the NOx Reduction System (NRS)
(2) Manifold absolute pressure sensor

- (3) Manifold air temperature sensor
(4) Water in fuel sensor
(5) Engine oil temperature sensor

- (6) Injection pressure regulator
(7) Engine fuel pressure sensor
(8) Air inlet heater

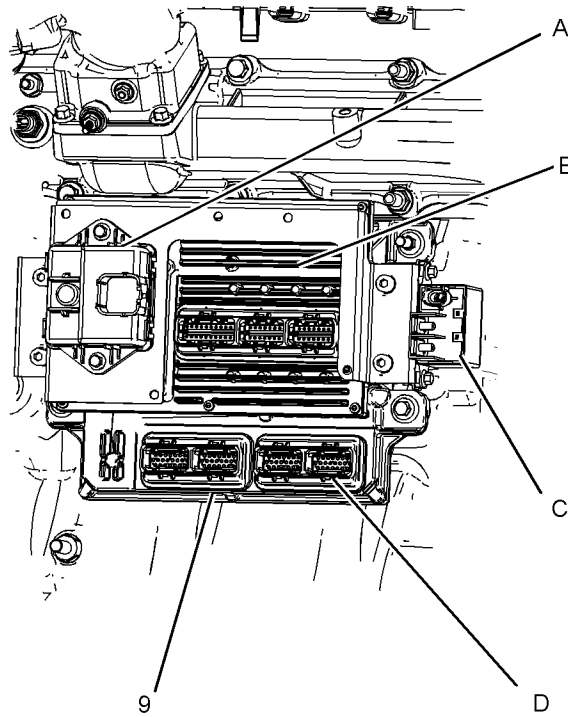

Illustration 28

g02732036

(9) Control module
(A) Driver for the NRS valve

(B) Injection Drive Module (IDM)
(C) High current relay

(D) Electronic Control Module (ECM)

Operation Section
Sensors and Electrical Components

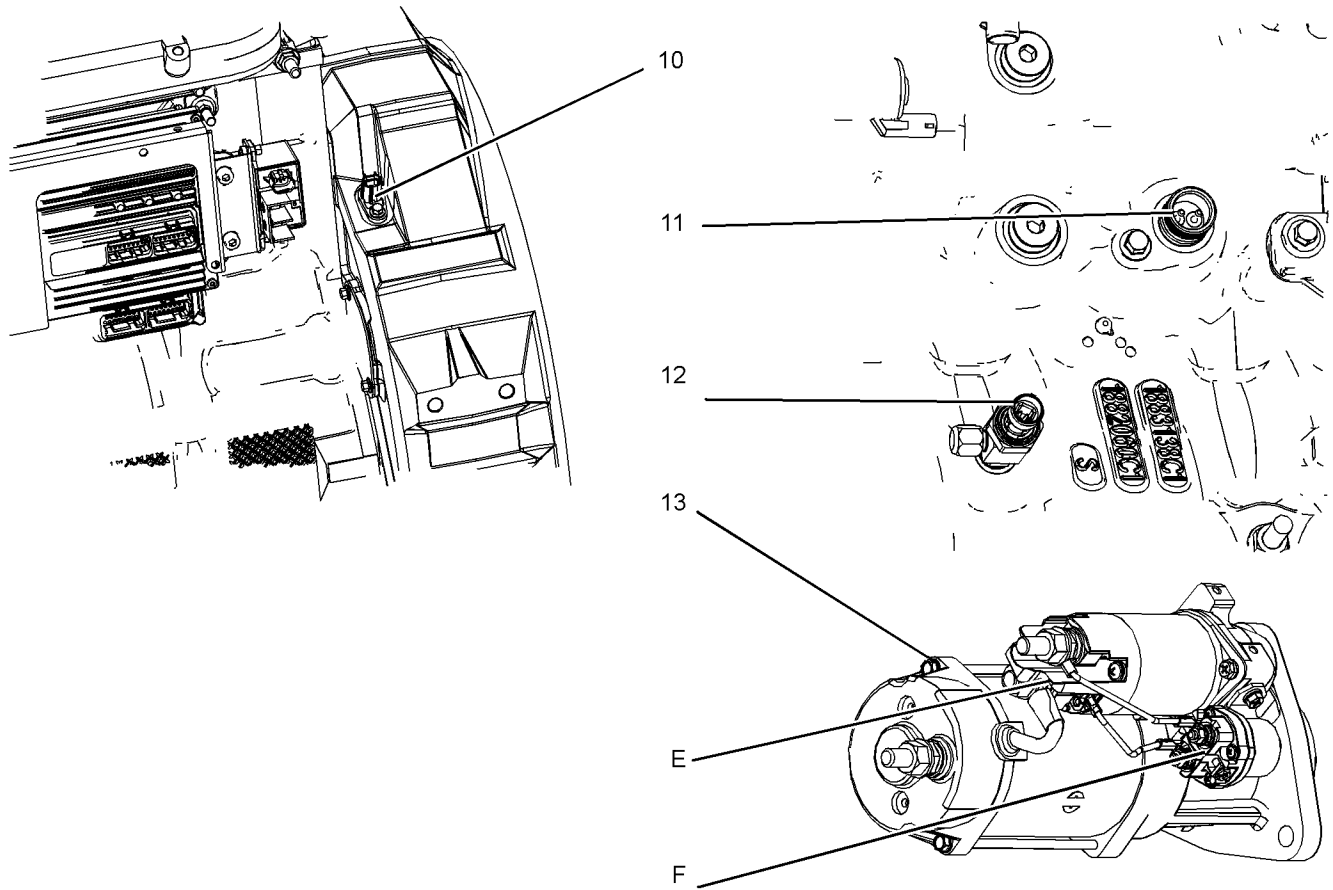

Illustration 29

g02732039

(10) Crankshaft position sensor
(11) Coolant jacket heater

(12) Engine oil pressure sensor
(13) Starting motor

(E) Solenoid
(F) Relay

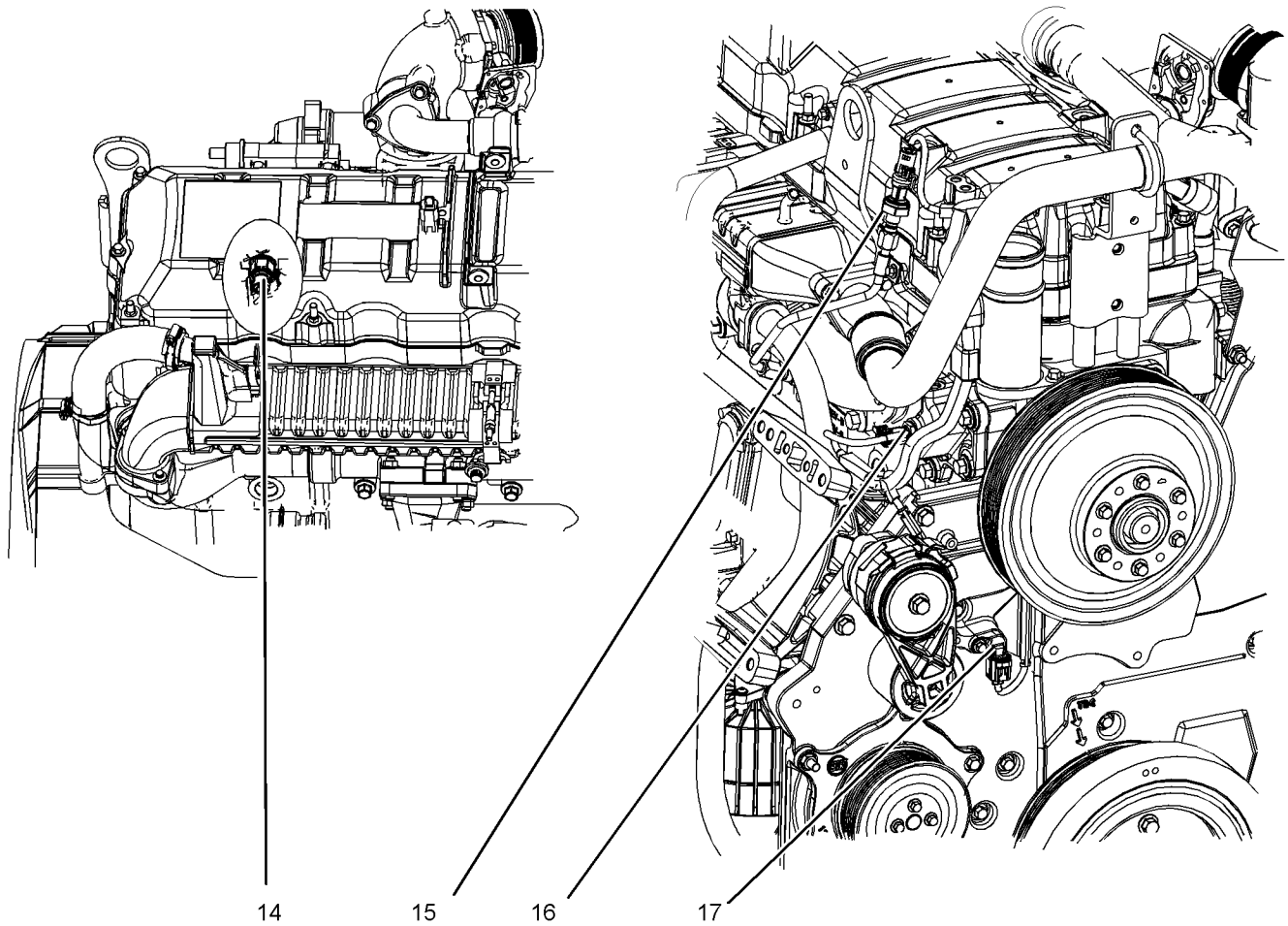

Illustration 30

g02732040

(14) Injection control pressure sensor
(15) Exhaust back pressure sensor

(16) Coolant temperature sensor
(17) Camshaft position sensor

Operation Section
Sensors and Electrical Components

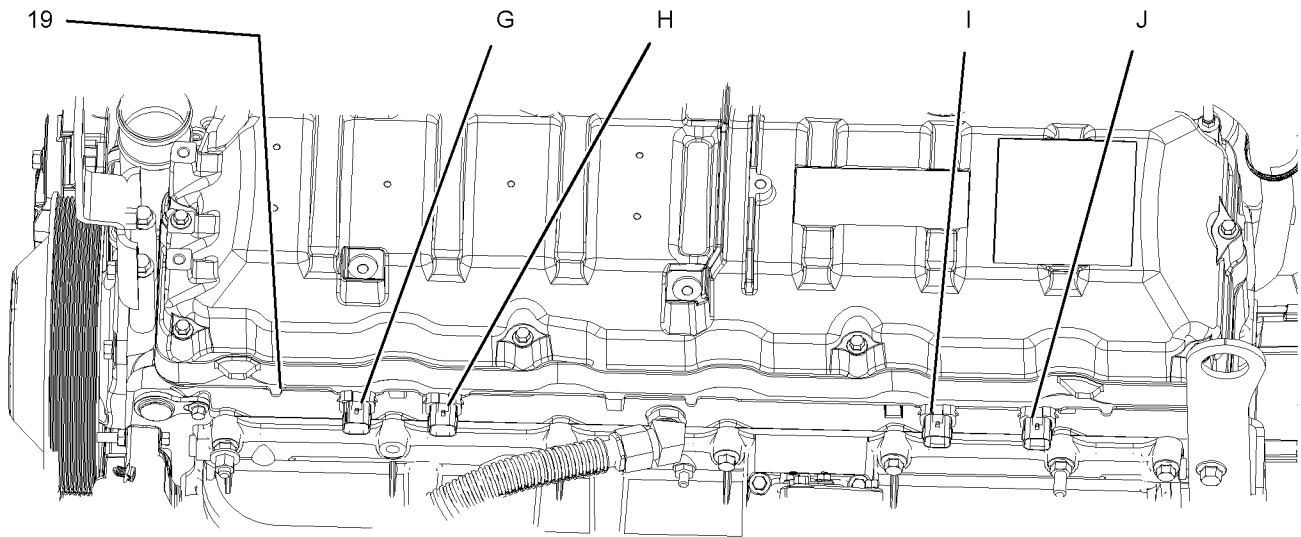

Illustration 31

g02740857

Item 18 alternator not shown.

(19) Connector and seal

(G) Injection control pressure connection

(H) Connector for injectors 1 and injector 2

(I) Connector for injectors 3 and injector 4

(J) Connector for injectors 5 and injector 6

Wiring Harness

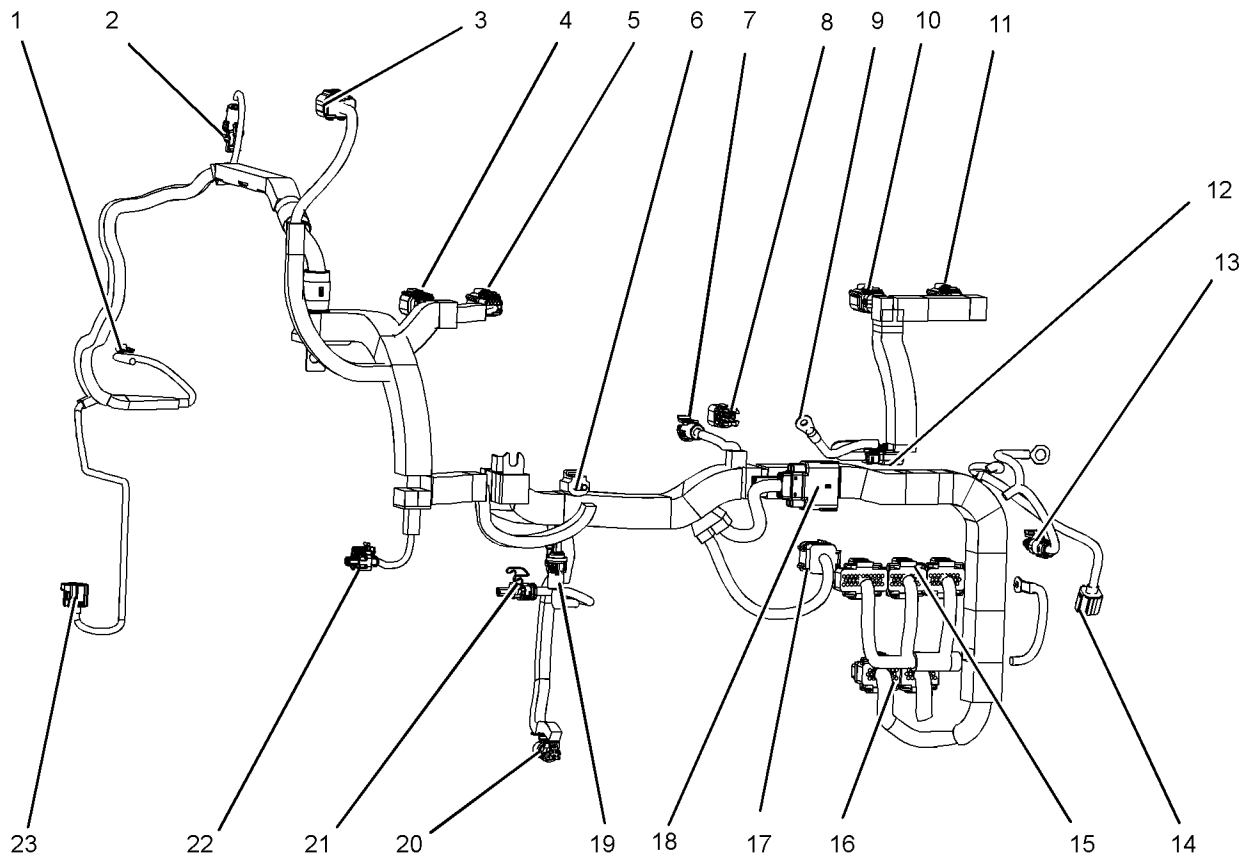

Illustration 32

g02740876

- | | | |
|--------------------------------|---------------------------------|-----------------------------------|
| (1) Coolant temperature | (9) Inlet heater terminal | (17) NRS drive |
| (2) Exhaust back pressure | (10) Injectors 3 and 4 | (18) Customer connection |
| (3) NRS | (11) Injectors 5 and 6 | (19) Low-pressure fuel |
| (4) Injection control | (12) Plug for inlet heater | (20) Engine oil pressure |
| (5) Injectors 1 and 2 | (13) Relay | (21) Injection pressure regulator |
| (6) Water in fuel | (14) Crankshaft position | (22) Oil temperature |
| (7) Inlet air temperature | (15) Injector drive connections | (23) Camshaft position connection |
| (8) Manifold absolute pressure | (16) ECM | |

Engine Diagnostics

i02784187

Self-Diagnostics

The electronic control module has some self-diagnostic ability. When an electronic problem with an input or an output is detected, a diagnostic code is generated. This indicates the specific problem with the circuitry.

A diagnostic code which represents a problem that currently exists is called an active code.

A diagnostic code that is stored in memory is called a logged code. Always service active codes prior to servicing logged codes. Logged codes may indicate intermittent problems.

Logged codes may not indicate that a repair is needed. The problems may have been repaired since the logging of the code. Logged codes may be helpful to troubleshoot intermittent problems.

i04801080

Fault Logging

The system provides the capability of Fault Logging. When the Electronic Control Module (ECM) generates an active diagnostic code, the code will be logged in the memory of the ECM. The Perkins electronic service tool can retrieve codes that have been logged. The codes that have been logged can be cleared with the Perkins electronic service tool.

i02651197

Engine Operation with Active Diagnostic Codes

If a diagnostic lamp illuminates during normal engine operation, the system has identified a situation that is not within the specification. Use the electronic service tool to check the active diagnostic codes.

The active diagnostic code should be investigated. The cause of the problem should be corrected as soon as possible. If the cause of the active diagnostic code is repaired and there is only one active diagnostic code, the diagnostic lamp will turn off.

Operation of the engine and performance of the engine can be limited as a result of the active diagnostic code that is generated. Acceleration rates may be significantly slower and power outputs may be automatically reduced. Refer to Troubleshooting , "Troubleshooting with a Diagnostic Code" for more information on the relationship between each active diagnostic code and the possible effect on engine performance.

i02784585

Engine Operation with Intermittent Diagnostic Codes

If a diagnostic lamp illuminates during normal engine operation and the diagnostic lamp shuts OFF, an intermittent fault may have occurred. If a fault has occurred, the fault will be logged into the memory of the Electronic Control Module (ECM).

In most cases, it is not necessary to stop the engine because of an intermittent code. However, the operator should retrieve the logged fault codes and the operator should reference the appropriate information in order to identify the nature of the fault. The operator should log any observation that could have caused the lamp to light.

- Low power
- Limits of the engine speed
- Excessive smoke, etc

This information can be useful to help troubleshoot the situation. The information can also be used for future reference. For more information on diagnostic codes, refer to the Troubleshooting guide for this engine.

Engine Starting

i02815193

i04268175

Before Starting Engine

Before the engine is started, perform the required daily maintenance and any other periodic maintenance that is due. Refer to the Operation and Maintenance Manual, "Maintenance Interval Schedule" for more information.

- Open the fuel supply valve (if equipped).

NOTICE

All valves in the fuel return line must be open before and during engine operation to help prevent high fuel pressure. High fuel pressure may cause filter housing failure or other damage.

If the engine has not been started for several weeks, fuel may have drained from the fuel system. Air may have entered the filter housing. Also, when fuel filters have been changed, some air pockets will be trapped in the engine. In these instances, prime the fuel system. Refer to the Operation and Maintenance Manual, "Fuel System - Prime" for more information on priming the fuel system.

WARNING

Engine exhaust contains products of combustion which may be harmful to your health. Always start and operate the engine in a well ventilated area and, if in an enclosed area, vent the exhaust to the outside.

- Do not start the engine or move any of the controls if there is a "DO NOT OPERATE" warning tag or similar warning tag attached to the start switch or to the controls.
- Reset all of the shutoffs or alarm components (if equipped).
- Ensure that any equipment that is driven by the engine has been disengaged from the engine. Minimize electrical loads or remove any electrical loads.
- Ensure that the coolant level is correct.
- Ensure that the engine oil level is correct.

Cold Weather Starting

WARNING

Do not use aerosol types of starting aids such as ether. Such use could result in an explosion and personal injury.

The engine will start at a temperature of -10°C (14°F). The ability to start at temperatures below 10°C (50°F) will improve by the use of a cylinder block coolant heater or a device which heats the crankcase oil. This will help to reduce white smoke and misfires when the engine is started in cold weather.

If the engine has not been run for several weeks, fuel may have drained. Air may have moved into the filter housing. Also, when fuel filters have been changed, some air will be left in the filter housing. Refer to Operation and Maintenance Manual, "Fuel System - Prime" in order to remove air from the fuel system.

Use the procedure that follows for cold weather starting.

NOTICE

Do not engage the starting motor when flywheel is turning. Do not start the engine under load.

If the engine fails to start within 30 seconds, release the starter switch or button and wait thirty seconds to allow the starting motor to cool before attempting to start the engine again.

1. If equipped, press the start button. If equipped, turn the keyswitch to the START position in order to engage the electric starting motor and crank the engine.
2. Repeat step 1 three times if the engine fails to start.
3. If the engine fails to start, investigate the problem. Use the Perkins electronic service tool. A system fault may be indicated after the engine is started. If this occurs the ECM has detected a problem with the system. Investigate the cause of the problem. Use the Perkins electronic service tool.

Note: Oil pressure should rise within 15 seconds after the engine starts. The electronic engine controls monitor the oil pressure. The electronic controls will stop the engine if the oil pressure is below normal.

4. Operate the engine at no load until all the coolant temperature starts to rise. Check the gauges during the warm-up period.

Note: The oil pressures and fuel pressures should be in the normal range on the instrument panel. Do not apply a load to the engine until the oil pressure gauge indicates at least normal pressure. Inspect the engine for leaks and/or unusual noises.

Note: After the ECM has completed the cold mode, cold mode cannot be enabled again until the ECM is switched OFF.

Note: Do not attempt to restart the engine until the engine has completely stopped.

i04268176

Starting the Engine

Note: Do not adjust the engine speed control during start-up. The electronic control module (ECM) will control the engine speed during start-up.

Starting the Engine

1. Disengage any equipment that is driven by the engine.
2. Turn the keyswitch to the ON position and wait for the wait to stat lamp to go off.

Note: The air inlet heat will be required in low ambient temperatures. The ECM will decide if the air heater element will be required to warm the intake air in order to start the engine.

3. Turn the keyswitch to the START position. Release the keyswitch when the engine starts. The keyswitch will return to the ON position.

NOTICE

Do not engage the starting motor when flywheel is turning. Do not start the engine under load.

If the engine fails to start within 30 seconds, release the starter switch or button and wait two minutes to allow the starting motor to cool before attempting to start the engine again.

4. With the engine in operation check the oil pressure. Oil pressure should be 103 kPa (15 psi) within seconds of engine operation, if oil pressure is incorrect, stop the engine and investigate immediately. If the engine cannot reach minimum oil pressure 276 kPa (40 psi) or other warning are activated, stop the engine and investigate immediately.
5. If the engine fails to start, repeat steps 2 to step 3.

6. If the engine fails to start after three attempts, determine the cause.

i02428473

Starting with Jump Start Cables

Do not use jump start cables in order to start the engine. Charge the batteries or replace the batteries. Refer to Operation and Maintenance Manual, "Battery - Replace".

i01646248

After Starting Engine

Note: In temperatures from 0 to 60°C (32 to 140°F), the warm-up time is approximately three minutes. In temperatures below 0°C (32°F), additional warm-up time may be required.

Note: Ensure that the self test for the monitoring system (if equipped) is completed before operating the engine under load.

When the engine idles during warm-up, observe the following conditions:

- Check for any fluid or for any air leaks at idle rpm and at one-half full rpm (no load on the engine) before operating the engine under load. This is not possible in some applications.
- Operate the engine at low idle until all systems achieve operating temperatures. Check all gauges during the warm-up period.

Note: Gauge readings should be observed and the data should be recorded frequently while the engine is operating. Comparing the data over time will help to determine normal readings for each gauge. Comparing data over time will also help detect abnormal operating developments. Significant changes in the readings should be investigated.

Engine Operation

i02578030

Engine Operation

Correct operation and maintenance are key factors in obtaining the maximum life and economy of the engine. If the directions in the Operation and Maintenance Manual are followed, costs can be minimized and engine service life can be maximized.

Gauge readings should be observed and the data should be recorded frequently while the engine is operating. Comparing the data over time will help to determine normal readings for each gauge. Comparing data over time will also help detect abnormal operating developments. Significant changes in the readings should be investigated.

i02583385

Fuel Conservation Practices

The efficiency of the engine can affect the fuel economy. Perkins design and technology in manufacturing provides maximum fuel efficiency in all applications. Follow the recommended procedures in order to attain optimum performance for the life of the engine.

- Avoid spilling fuel.

Fuel expands when the fuel is warmed up. The fuel may overflow from the fuel tank. Inspect fuel lines for leaks. Repair the fuel lines, as needed.

- Be aware of the properties of the different fuels. Use only the recommended fuels.
- Avoid unnecessary operation at no load.

Shut off the engine instead of operating the engine at no load for long periods of time.

- Observe the service indicator for the air cleaner frequently, if equipped. Keep the air cleaner elements clean.
- Maintain a good electrical system.

One bad battery cell will overwork the alternator. This will consume excess power and excess fuel.

- Ensure that the belts are properly adjusted. The belts should be in good condition.
- Ensure that all of the connections of the hoses are tight. The connections should not leak.

- Ensure that the driven equipment is in good working order.
- Cold engines consume excess fuel. Keep cooling system components clean and keep cooling system components in good repair. Never operate the engine without water temperature regulators. All of these items will help maintain operating temperatures.

Cold Weather Operation

i04564559

Cold Weather Operation

Perkins Diesel Engines can operate effectively in cold weather. During cold weather, the starting and the operation of the diesel engine is dependent on the following items:

- The type of fuel that is used
- The viscosity of the engine oil
- Optional Cold starting aid
- Battery condition

The operation and maintenance of an engine in freezing temperatures is complex, because of the following conditions:

- Weather conditions
- Engine applications

Recommendations from your Perkins distributor are based on past proven practices. The information that is contained in this section provides guidelines for cold-weather operation.

Hints for Cold Weather Operation

- If the engine will start, operate the engine until a minimum operating temperature of 81 °C (177.8 °F) is achieved. Achieving operating temperature will help prevent the intake valves and exhaust valves from sticking.
- The cooling system and the lubrication system for the engine do not lose heat immediately upon shutdown. This means that an engine can be shut down for a time and the engine can still have the ability to start readily.
- Install the correct specification of engine lubricant before the beginning of cold weather.
- Check all rubber parts (hoses, drive belts,) weekly.
- Check all electrical wiring and connections for any fraying or damaged insulation.
- Keep all batteries fully charged and warm.
- Check the air cleaners and the air intake daily.

WARNING

Personal injury or property damage can result from alcohol or starting fluids.

Alcohol or starting fluids are highly flammable and toxic and if improperly stored could result in injury or property damage.

WARNING

Do not use aerosol types of starting aids such as ether. Such use could result in an explosion and personal injury.

Viscosity of the Engine Lubrication Oil

Correct engine oil viscosity is essential. Oil viscosity affects the amount of torque that is needed to crank the engine. Refer to Operation and Maintenance Manual, "Fluid Recommendations" for the recommended viscosity of oil.

Recommendations for the Coolant

Provide cooling system protection for the lowest expected outside temperature. Refer to this Operation and Maintenance Manual, "Fluid Recommendations" for the recommended coolant mixture.

In cold weather, check the coolant often for the correct glycol concentration in order to ensure adequate freeze protection.

Coolant Jacket Heaters

If installed, the coolant jacket heater heats the engine jacket coolant that surrounds the cylinder block. This added heat provides the following function:

- Startability is improved.

An electric heater can be activated once the engine is stopped. An effective heater is typically a 1250 W at 120 V. If your engine is to operate in a cold environment, consult your Perkins distributor for more information. An oil pan heater may also be required.

i02576035

Fuel and the Effect from Cold Weather

Note: Only use grades of fuel that are recommended by Perkins. Refer to this Operation and Maintenance Manual, "Fluid Recommendations".

The following fuels can be used in this series of engine.

- Group 1
- Group 2
- Group 3
- Special Fuels

Perkins prefer only Group 1 and Group 2 fuels for use in this series of engines.

Group 1 fuels are the preferred Group of Fuels for general use by Perkins. Group 1 fuels maximize engine life and engine performance. Group 1 fuels are usually less available than Group 2 fuels. Frequently, Group 1 fuels are not available in colder climates during the winter.

Note: Group 2 fuels must have a maximum wear scar of 650 micrometers (HFRR to ISO 12156-1).

Group 2 fuels are considered acceptable for issues of warranty. This group of fuels may reduce the life of the engine, the engine's maximum power, and the engine's fuel efficiency.

When Group 2 diesel fuels are used the following components provide a means of minimizing problems in cold weather:

- Glow plugs (if equipped)
- Engine coolant heaters, which may be an OEM option
- Fuel heaters, which may be an OEM option
- Fuel line insulation, which may be an OEM option

There are three major differences between Group 1 fuels and Group 2 fuels. Group 1 fuels have the following different characteristics to Group 2 fuels.

- A lower cloud point

- A lower pour point
- A lower energy per unit volume of fuel

Note: Group 3 fuels reduce the life of the engine. The use of Group 3 fuels is not covered by the Perkins warranty.

Group 3 fuels include Low Temperature Fuels and Aviation Kerosene Fuels.

Special fuels include Biofuel.

The cloud point is a temperature that allows wax crystals to form in the fuel. These crystals can cause the fuel filters to plug.

The pour point is the temperature when diesel fuel will thicken. The diesel fuel becomes more resistant to flow through fuel lines, fuel filters, and fuel pumps.

Be aware of these facts when diesel fuel is purchased. Consider the average ambient air temperature for the engine's application. Engines that are fueled in one climate may not operate well if the engines are moved to another climate. Problems can result due to changes in temperature.

Before troubleshooting for low power or for poor performance in the winter, check the fuel for waxing.

Low temperature fuels may be available for engine operation at temperatures below 0 °C (32 °F). These fuels limit the formation of wax in the fuel at low temperatures.

For more information on cold weather operation, refer to the Operation and Maintenance Manual, "Cold Weather Operation and Fuel Related Components in Cold Weather".

i04268370

Fuel Related Components in Cold Weather

Fuel Tanks

Condensation can form in partially filled fuel tanks. Top off the fuel tanks after you operate the engine.

Fuel tanks should contain some provision for draining water and sediment from the bottom of the tanks. Some fuel tanks use supply pipes that allow water and sediment to settle below the end of the fuel supply pipe.

Some fuel tanks use supply lines that take fuel directly from the bottom of the tank. If the engine is equipped with this system, regular maintenance of the fuel system filter is important.

Drain the water and sediment from any fuel storage tank at the following intervals: weekly, oil changes and refueling of the fuel tank. This draining will help prevent water and/or sediment from being pumped from the fuel storage tank and into the engine fuel tank.

Fuel Filter

A strainer and fuel filter is installed between the fuel tank and the electronic fuel injectors. After you change the fuel filter, always prime the fuel system in order to remove air bubbles from the fuel system. Refer to the Operation and Maintenance Manual in the Maintenance Section for more information on priming the fuel system.

Engine Stopping

i02583411

Stopping the Engine

i04268255

NOTICE

Stopping the engine immediately after it has been working under load, can result in overheating and accelerated wear of the engine components.

Avoid accelerating the engine prior to shutting it down.

Avoiding hot engine shutdowns will maximize turbo-charger shaft and bearing life.

Note: Individual applications will have different control systems. Ensure that the shutoff procedures are understood. Use the following general guidelines in order to stop the engine.

1. Remove the load from the engine. Allow the engine to run under no load conditions for 5 minutes in order to cool the engine.
2. Stop the engine after the cool down period according to the shutoff system on the engine and turn the ignition keyswitch to the OFF position. If necessary, refer to the instructions that are provided by the OEM.

i07764840

Emergency Stopping

NOTICE

Emergency shutoff controls are for EMERGENCY use ONLY. DO NOT use emergency shutoff devices or controls for normal stopping procedure.

The Original Equipment Manufacturer (OEM) may have equipped the application with an emergency stop button. For more information about the emergency stop button, refer to the OEM information.

Ensure that any components for the external system that support the engine operation are secured after the engine is stopped.

After Stopping Engine

Note: Before you check the engine oil, do not operate the engine for at least 10 minutes in order to allow the engine oil to return to the oil pan.

- Check the crankcase oil level. Maintain the oil level between the “LOW” mark and the “HIGH” mark on the oil level gauge.

Note: Only use oil that is recommended in this Operation and Maintenance Manual, “Fluid Recommendations”. Failure to use the recommended oil may result in engine damage.

- If necessary, perform minor adjustments. Repair any leaks and tighten any loose bolts.
- Note the service hour meter reading. Perform the maintenance that is in the Operation and Maintenance Manual, “Maintenance Interval Schedule”.
- Fill the fuel tank in order to help prevent accumulation of moisture in the fuel. Do not overfill the fuel tank.
- Allow the engine to cool. Check the coolant level. Maintain the cooling system at 13 mm (0.5 inch) from the bottom of the pipe for filling.

Note: Only use coolant that is recommended in this Operation and Maintenance Manual, “Fluid Recommendations”. Failure to use the recommended oil may result in engine damage.

- If freezing temperatures are expected, check the coolant for proper antifreeze protection. The cooling system must be protected against freezing to the lowest expected outside temperature. Add the proper coolant/water mixture, if necessary.
- Perform all required periodic maintenance on all driven equipment. This maintenance is outlined in the instructions from the OEM.

Maintenance Section

Refill Capacities

i04268391

Refill Capacities

Lubrication System

The refill capacities for the engine crankcase reflect the approximate capacity of the crankcase or sump plus standard oil filters. Auxiliary oil filter systems will require additional oil. Refer to the OEM specifications for the capacity of the auxiliary oil filter. Refer to the Operation and Maintenance Manual, "Maintenance Section" for more information on Lubricant Specifications.

Table 5

Engine Refill Capacities	
Compartment or System	Maximum
Crankcase Oil Sump ⁽¹⁾	35.96 L (7.9 Imp gal)

⁽¹⁾ These values are the approximate capacities for the crankcase oil sump which includes the standard factory installed oil filters. Engines with auxiliary oil filters will require additional oil. Refer to the OEM specifications for the capacity of the auxiliary oil filter.

Cooling System

Refer to the OEM specifications for the External System capacity. This capacity information will be needed in order to determine the amount of coolant that is required for the Total Cooling System.

Table 6

Engine Refill Capacities	
Compartment or System	
1600A Engine Only	11.8 L (2.6 Imp gal)
1600A Total System	30.9 L (6.8 Imp gal)

(continued)

(Table 6, contd)

Engine Refill Capacities	
Compartment or System	
1600D Engine Only	13.2 L (2.9 Imp gal)
1600D Total System	32.3 L (7.1 Imp gal)

i04268496

Fluid Recommendations

General Coolant Information

NOTICE

Never add coolant to an overheated engine. Engine damage could result. Allow the engine to cool first.

NOTICE

If the engine is to be stored in, or shipped to an area with below freezing temperatures, the cooling system must be either protected to the lowest outside temperature or drained completely to prevent damage.

NOTICE

Frequently check the specific gravity of the coolant for proper freeze protection or for anti-boil protection.

Clean the cooling system for the following reasons:

- Contamination of the cooling system
- Overheating of the engine
- Foaming of the coolant

NOTICE

Never operate an engine without water temperature regulators in the cooling system. Water temperature regulators help to maintain the engine coolant at the proper operating temperature. Cooling system problems can develop without water temperature regulators.

Many engine failures are related to the cooling system. The following problems are related to cooling system failures: Overheating, leakage of the water pump and plugged radiators or heat exchangers.

These failures can be avoided with correct cooling system maintenance. Cooling system maintenance is as important as maintenance of the fuel system and the lubrication system. Quality of the coolant is as important as the quality of the fuel and the lubricating oil.

Coolant Recommendations

- ELC _____ Extended Life Coolant
- SCA _____ Supplement Coolant Additive
- ASTM _____ American Society for Testing and Materials

The following two coolants are used in Perkins diesel engines:

Preferred – Perkins ELC

Acceptable – A commercial heavy-duty antifreeze that meets “ASTM D6210” specifications

NOTICE

The 1600 series industrial engines must be operated with a 1:1 mixture of water and glycol. This concentration allows the NOx reduction system to operate correctly at high ambient temperatures.

NOTICE

Do not use a commercial coolant/antifreeze that only meets the ASTM D3306 specification. This type of coolant/antifreeze is made for light automotive applications.

Perkins recommends a 1:1 mixture of water and glycol. This mixture of water and glycol will provide optimum heavy-duty performance as an antifreeze. This ratio may be increased to 1:2 water to glycol if extra freezing protection is required.

Table 7

Coolant Service Life	
Coolant Type	Service Life ⁽¹⁾
Perkins ELC	6,000 Service Hours or Three Years ⁽²⁾
Commercial Heavy-Duty Antifreeze that meets “ASTM D6210”	3000 Service Hours or Two Year

⁽¹⁾ Use the interval that occurs first. The cooling system must also be flushed out at this time.

⁽²⁾ ELC can be extended to 12000 hours by using an approved extender.

ELC

Perkins provides ELC for use in the following applications:

- Heavy-duty spark ignited gas engines
- Heavy-duty diesel engines
- Automotive applications

The anti-corrosion package for ELC is different from the anti-corrosion package for other coolants. ELC is an ethylene glycol base coolant. However, ELC contains organic corrosion inhibitors and antifoam agents with low amounts of nitrite. Perkins ELC has been formulated with the correct amount of these additives in order to provide superior corrosion protection for all metals in engine cooling systems.

ELC is available in a premixed cooling solution with distilled water. ELC is a 1:1 mixture. The Premixed ELC provides freeze protection to -36 °C (-33 °F). The Premixed ELC is recommended for the initial fill of the cooling system. The Premixed ELC is also recommended for topping off the cooling system.

Containers of several sizes are available. Consult your Perkins distributor for the part numbers.

ELC Cooling System Maintenance

Correct additions to the Extended Life Coolant

NOTICE

Use only Perkins products for pre-mixed or concentrated coolants.

Mixing Extended Life Coolant with other products reduces the Extended Life Coolant service life. Failure to follow the recommendations can reduce cooling system components life unless appropriate corrective action is performed.

In order to maintain the correct balance between the antifreeze and the additives, you must maintain the recommended concentration of ELC. Lowering the proportion of antifreeze lowers the proportion of additive. This lowering will lower the ability of the coolant to protect the system from pitting, from cavitation, from erosion, and from deposits.

NOTICE

Do not use a conventional coolant to top-off a cooling system that is filled with Extended Life Coolant (ELC).

Do not use standard supplemental coolant additive (SCA).

When using Perkins ELC, do not use standard SCA's or SCA filters.

ELC Cooling System Cleaning

Note: If the cooling system is already using ELC, cleaning agents are not required to be used at the specified coolant change interval. Cleaning agents are only required if the system has been contaminated by the addition of some other type of coolant or by cooling system damage.

Clean water is the only cleaning agent that is required when ELC is drained from the cooling system.

Before the cooling system is filled, the heater control (if equipped) must be set to the HOT position. Refer to the OEM in order to set the heater control. After the cooling system is drained and the cooling system is refilled, operate the engine until the coolant level reaches the normal operating temperature and until the coolant level stabilizes. As needed, add the coolant mixture in order to fill the system to the specified level.

Changing to Perkins ELC

To change from heavy-duty antifreeze to the Perkins ELC, perform the following steps:

NOTICE

Care must be taken to ensure that all fluids are contained during performance of inspection, maintenance, testing, adjusting and the repair of the product. Be prepared to collect the fluid with suitable containers before opening any compartment or disassembling any component containing fluids.

Dispose of all fluids according to local regulations and mandates.

1. Drain the coolant into a suitable container.
2. Dispose of the coolant according to local regulations.
3. Flush the system with clean water in order to remove any debris.
4. Use an approved Perkins cleaner to clean the system. Follow the instruction on the label.
5. Drain the cleaner into a suitable container. Flush the cooling system with clean water.
6. Fill the cooling system with clean water and operate the engine until the engine is warmed to 49° to 66°C (120° to 150°F).

NOTICE

Incorrect or incomplete flushing of the cooling system can result in damage to copper and other metal components.

To avoid damage to the cooling system, make sure to completely flush the cooling system with clear water. Continue to flush the system until all the signs of the cleaning agent are gone.

7. Drain the cooling system into a suitable container and flush the cooling system with clean water.

Note: The cooling system cleaner must be thoroughly flushed from the cooling system. Cooling system cleaner that is left in the system will contaminate the coolant. The cleaner may also corrode the cooling system.

8. Repeat Steps 6 and repeat steps 7 until the system is completely clean.
9. Fill the cooling system with the Perkins Premixed ELC.

ELC Cooling System Contamination

NOTICE

Mixing ELC with other products reduces the effectiveness of the ELC and shortens the ELC service life. Use only Perkins Products for premixed or concentrate coolants. Failure to follow these recommendations can result in shortened cooling system component life.

ELC cooling systems can withstand contamination to a maximum of 10 percent of conventional heavy-duty antifreeze or SCA. If the contamination exceeds 10 percent of the total system capacity, perform ONE of the following procedures:

- Drain the cooling system into a suitable container. Dispose of the coolant according to local regulations. Flush the system with clean water. Fill the system with the Perkins ELC.
- Drain a portion of the cooling system into a suitable container according to local regulations. Then, fill the cooling system with premixed ELC. This procedure should lower the contamination to less than 10 percent.
- Maintain the system as a conventional Heavy-Duty Coolant. Treat the system with an SCA. Change the coolant at the interval that is recommended for the conventional Heavy-Duty Coolant.

Commercial Heavy-Duty Antifreeze and SCA

NOTICE

Commercial Heavy-Duty Coolant which contains Amine as part of the corrosion protection system must not be used.

NOTICE

Never operate an engine without water temperature regulators in the cooling system. Water temperature regulators help to maintain the engine coolant at the correct operating temperature. Cooling system problems can develop without water temperature regulators.

Check the antifreeze (glycol concentration) in order to ensure adequate protection against boiling or freezing. Perkins recommends the use of a refractometer for checking the glycol concentration. A hydrometer should not be used.

Perkins engine cooling systems should be tested at 500 hour intervals for the concentration of SCA.

Additions of SCA are based on the results of the test. An SCA that is liquid may be needed at 500 hour intervals.

Adding the SCA to Heavy-Duty Coolant at the Initial Fill

Commercial heavy-duty antifreeze that meets “ASTM D4985” specifications MAY require an addition of SCA at the initial fill. Read the label or the instructions that are provided by the OEM of the product.

Use the equation that is in Table 8 to determine the amount of Perkins SCA that is required when the cooling system is initially filled.

Table 8

Equation For Adding The SCA To The Heavy-Duty Coolant At The Initial Fill
$V \times 0.045 = X$
V is the total volume of the cooling system.
X is the amount of SCA that is required.

Table 9 is an example for using the equation that is in Table 8 .

Table 9

Example Of The Equation For Adding The SCA To The Heavy-Duty Coolant At The Initial Fill		
Total Volume of the Cooling System (V)	Multiplication Factor	Amount of SCA that is Required (X)
15 L (4 US gal)	× 0.045	0.7 L (24 oz)

Adding The SCA to The Heavy-Duty Coolant For Maintenance

Heavy-duty antifreeze of all types REQUIRE periodic additions of an SCA.

Test the antifreeze periodically for the concentration of SCA. For the interval, refer to the Operation and Maintenance Manual, “Maintenance Interval Schedule” (Maintenance Section). Test the concentration of SCA.

Additions of SCA are based on the results of the test. The size of the cooling system determines the amount of SCA that is needed.

Use the equation that is in Table 10 to determine the amount of Perkins SCA that is required, if necessary:

Table 10

Equation For Adding The SCA To The Heavy-Duty Coolant For Maintenance
$V \times 0.014 = X$
V is the total volume of the cooling system.
X is the amount of SCA that is required.

Table 11 is an example for using the equation that is in Table 10 .

Table 11

Example Of The Equation For Adding The SCA To The Heavy-Duty Coolant For Maintenance		
Total Volume of the Cooling System (V)	Multiplication Factor	Amount of SCA that is Required (X)
15 L (4 US gal)	× 0.014	0.2 L (7 oz)

Cleaning the System of Heavy-Duty Antifreeze

Perkins cooling system cleaners are designed to clean the cooling system of harmful scale and corrosion. Perkins cooling system cleaners dissolve mineral scale, corrosion products, light oil contamination, and sludge.

- Clean the cooling system after used coolant is drained or before the cooling system is filled with new coolant.

- Clean the cooling system whenever the coolant is contaminated or whenever the coolant is foaming.

i04268520

Fluid Recommendations

General Lubricant Information

Because of government regulations regarding the certification of exhaust emissions from the engine, the lubricant recommendations must be followed.

- API _____ American Petroleum Institute
- SAE _____ Society Of Automotive Engineers Inc.

Licensing

The Engine Oil Licensing and Certification System by the American Petroleum Institute (API) is recognized by Perkins. For detailed information about this system, see the latest edition of the “API publication No. 1509”. Engine oils that bear the API symbol are authorized by API.

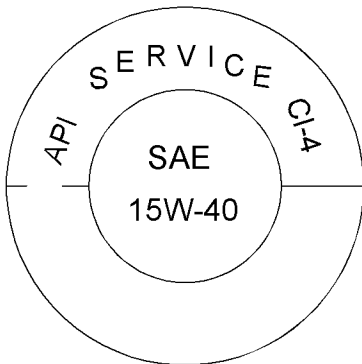

Illustration 33

Typical API symbol

g02956479

Terminology

Certain abbreviations follow the nomenclature of “SAE J754”. Some classifications follow “SAE J183” abbreviations, and some classifications follow the “EMA Recommended Guideline on Diesel Engine Oil”. In addition to Perkins definitions, there are other definitions that will be of assistance in purchasing lubricants. Recommended oil viscosities can be found in this publication, “Fluid Recommendations/ Engine Oil” topic (Maintenance Section).

Engine Oils

Commercial Oils

NOTICE

Perkins require the use of the following specification of engine oil. Failure to use the appropriate specification of engine oil will reduce the life of your engine.

Table 12

Classifications for the 1600 Series Industrial Engine
Oil Specification
API CI-4

Maintenance intervals for engines that use biodiesel – The oil change interval can be adversely affected by the use of biodiesel. Use oil analysis in order to monitor the condition of the engine oil. Use oil analysis also in order to determine the oil change interval that is optimum.

Lubricant Viscosity Recommendations for Direct Injection (DI) Diesel Engines

The correct SAE viscosity grade of oil is determined by the minimum ambient temperature during cold engine start-up, and the maximum ambient temperature during engine operation.

Refer to illustration 34 (minimum temperature) in order to determine the required oil viscosity for starting a cold engine.

Refer to illustration 34 (maximum temperature) in order to select the oil viscosity for engine operation at the highest ambient temperature that is anticipated.

Generally, use the highest oil viscosity that is available to meet the requirement for the temperature at start-up.

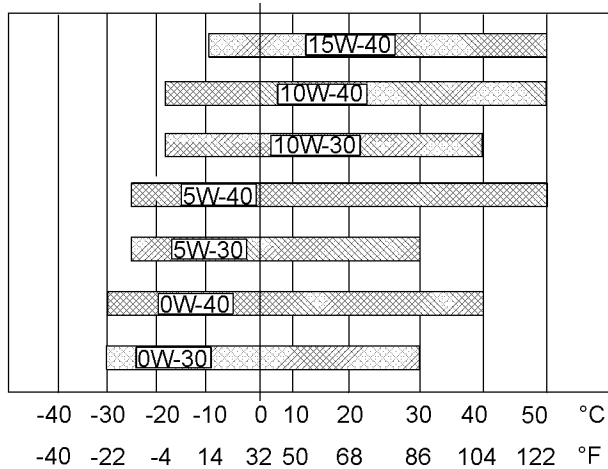

Illustration 34

g02940936

Lubricant Viscosities

Supplemental heat is recommended for cold soaked starts below the minimum ambient temperature. Supplemental heat may be required for cold soaked starts that are above the minimum temperature that is stated, depending on the parasitic load and other factors. Cold soaked starts occur when the engine has not been operated for a period of time. This interval will allow the oil to become more viscous due to cooler ambient temperatures.

Aftermarket Oil Additives

Perkins does not recommend the use of aftermarket additives in oil. It is not necessary to use aftermarket additives in order to achieve the engines maximum service life or rated performance. Fully formulated, finished oils consist of base oils and of commercial additive packages. These additive packages are blended into the base oils at precise percentages in order to help provide finished oils with performance characteristics that meet industry standards.

There are no industry standard tests that evaluate the performance or the compatibility of aftermarket additives in finished oil. Aftermarket additives may not be compatible with the finished oils additive package, which could lower the performance of the finished oil. The aftermarket additive could fail to mix with the finished oil. This failure could produce sludge in the crankcase. Perkins discourages the use of aftermarket additives in finished oils.

To achieve the best performance from a Perkins engine, conform to the following guidelines:

- See the appropriate “Lubricant Viscosities”. Refer to the illustration 34 in order to find the correct oil viscosity grade for your engine.

- At the specified interval, service the engine. Use new oil and install a new oil filter.
- Perform maintenance at the intervals that are specified in the Operation and Maintenance Manual, “Maintenance Interval Schedule”.

Oil analysis

Some engines may be equipped with an oil sampling valve. If oil analysis is required, the oil sampling valve is used to obtain samples of the engine oil. The oil analysis will complement the preventive maintenance program.

The oil analysis is a diagnostic tool that is used to determine oil performance and component wear rates. Contamination can be identified and measured by using oil analysis. The oil analysis includes the following tests:

- The Wear Rate Analysis monitors the wear of the engines metals. The amount of wear metal and type of wear metal that is in the oil is analyzed. The increase in the rate of engine wear metal in the oil is as important as the quantity of engine wear metal in the oil.
- Tests are conducted in order to detect contamination of the oil by water, glycol, or fuel.
- The Oil Condition Analysis determines the loss of the oils lubricating properties. An infrared analysis is used to compare the properties of new oil to the properties of the used oil sample. This analysis allows technicians to determine the amount of deterioration of the oil during use. This analysis also allows technicians to verify the performance of the oil according to the specification during the entire oil change interval.

i04268521

Fluid Recommendations

- **Glossary**
- ISO International Standards Organization
- ASTM American Society for Testing and Materials
- HFRR High Frequency Reciprocating Rig for Lubricity testing of diesel fuels
- FAME Fatty Acid Methyl Esters
- CFR Co-ordinating Fuel Research
- LSD Low Sulfur Diesel
- RME Rape Methyl Ester

- SME Soy Methyl Ester
- EPA Environmental Protection Agency of the United States

General Information

NOTICE

Every attempt is made to provide accurate, up-to-date information. By use of this document you agree that Perkins Engines Company Limited is not responsible for errors or omissions.

NOTICE

These recommendations are subject to change without notice. Contact your local Perkins distributor for the most up-to-date recommendations.

Diesel Fuel Requirements

Perkins is not in a position to continuously evaluate and monitor all worldwide distillate diesel fuel specifications that are published by governments and technological societies.

Table 13 provides a known reliable baseline in order to judge the expected performance of distillate diesel fuels that are derived from conventional sources.

Satisfactory engine performance is dependent on the use of a good quality fuel. The use of a good quality fuel will give the following results: long engine life and acceptable exhaust emissions levels. The fuel must meet the minimum requirements that are stated in table 13 .

NOTICE

The footnotes are a key part of the Perkins Specification for Distillate Diesel Fuel Table. Read ALL of the footnotes.

Table 13

Perkins Specification for Distillate Diesel Fuel				
Property	UNITS	Requirements	"ASTM"Test	"ISO"Test
Aromatics	%Volume	35% maximum	D1319	"ISO"3837
Ash	%Weight	0.01% maximum	D482	"ISO"6245
Carbon Residue on 10% Bottoms	%Weight	0.35% maximum	D524	"ISO"4262
Cetane Number ⁽¹⁾	-	40 minimum	D613/D6890	"ISO"5165
Cloud Point	°C	The cloud point must not exceed the lowest expected ambient temperature.	D2500	"ISO"3015

(continued)

(Table 13, contd)

Copper Strip Corrosion	-	No. 3 maximum	D130	"ISO"2160
Density at 15 °C (59 °F) (2)	Kg / M ³	801 minimum and 876 maximum	No equivalent test	"ISO 3675""ISO 12185"
Distillation	°C	10% at 282 °C (539.6 °F) maximum 90% at 360 °C (680 °F) maximum	D86	"ISO"3405
Flash Point	°C	legal limit	D93	"ISO"2719
Thermal Stability	-	Minimum of 80% reflectance after aging for 180 minutes at 150 °C (302 °F)	D6468	No equivalent test
Pour Point	°C	6 °C (42.8 °F) minimum below ambient temperature	D97	"ISO"3016
Sulfur (3)	%mass	1606A Engine 1% maximum	D5453/D26222	"ISO 20846""ISO 20884"
		1606D Engine 0.05% maximum		
Kinematic Viscosity (4)	"MM" ² /S (cSt)"	The viscosity of the fuel that is delivered to the fuel injection pump. "1.4 minimum/ 4.5 maximum"	D445	"ISO"3405
Water and sediment	% weight	0.1% maximum	D1796	"ISO"3734
Water	% weight	0.1% maximum	D6304	No equivalent test
Sediment	% weight	0.05% maximum	D473	"ISO"3735
Gums and Resins (5)	mg/100mL	10 mg per 100 mL maximum	D381	"ISO"6246
Lubricity corrected wear scar diameter at 60 °C (140 °F). (6)	mm	0.46 maximum	D6079	"ISO"12156-1

(1) A fuel with a higher cetane number is recommended in order to operate at a higher altitude or in cold weather.

(2) "Via standards tables, the equivalent API gravity for the minimum density of 801 kg / m³ (kilograms per cubic meter) is 45 and for the maximum density of 876 kg / m³ is 30".

(3) Regional regulations, national regulations, or international regulations can require a fuel with a specific sulfur limit. Consult all applicable regulations before selecting a fuel for a given engine application. The **1606A** engine models can operate with fuels sulphur >500 PPM (0.05%) where legislation allows use of such a fuel. sulfur fuels. The **1606D** engine models have been developed to operate with LSD fuel ≤500 (0.05%) sulphur. High sulfur fuels also increase the potential for corrosion of internal components. Fuel sulfur levels above 0.5% may significantly shorten the oil change interval. For additional information, refer to this manual, "Fluid recommendations (General lubricant Information)".

(4) The values of the fuel viscosity are the values as the fuel is delivered to the fuel injection pumps. Fuel should also meet the minimum viscosity requirement and the fuel should meet the maximum viscosity requirements at 40 °C (104 °F) of either the "ASTM D445" test method or the "ISO 3104" test method. If a fuel with a low viscosity is used, cooling of the fuel may be required to maintain 1.4 cSt or greater viscosity at the fuel injection pump. Fuels with a high viscosity might require fuel heaters in order to lower the viscosity to 4.5 cSt at the fuel injection pump.

(5) Follow the test conditions and procedures for gasoline (motor).

(6) The lubricity of a fuel is a concern with low sulfur and ultra low sulfur fuel. To determine the lubricity of the fuel, use the "ISO 12156-1 or ASTM D6079 High Frequency Reciprocating Rig (HFRR)" test. If the lubricity of a fuel does not meet the minimum requirements, consult your fuel supplier. Do not treat the fuel without consulting the fuel supplier. Some additives are not compatible. These additives can cause problems in the fuel system.

NOTICE

Operating with fuels that do not meet the Perkins recommendations can cause the following effects: Starting difficulty, poor combustion, deposits in the fuel injectors, reduced service life of the fuel system, deposits in the combustion chamber and reduced service life of the engine.

Engines that are manufactured by Perkins are certified with the fuel that is prescribed by the United States Environmental Protection Agency. Engines that are manufactured by Perkins are certified with the fuel that is prescribed by the European Certification and other regulatory agencies. Perkins does not certify diesel engines on any other fuel.

Note: The owner and the operator of the engine has the responsibility of using the fuel that is prescribed by the EPA and other appropriate regulatory agencies.

Diesel Fuel Characteristics

Perkins Recommendations

Cetane Number

Fuel that has a high cetane number will give a shorter ignition delay. A high cetane number will produce a better ignition quality. Cetane numbers are derived for fuels against proportions of cetane and heptamethylnonane in the standard CFR engine. Refer to "ISO 5165" for the test method.

Cetane numbers in excess of 45 are normally expected from current diesel fuel. However, a cetane number of 40 may be experienced in some territories. The United States of America is one of the territories that can have a low cetane value. A minimum cetane value of 40 is required during average starting conditions. A higher cetane value may be required for operations at high altitudes or in cold-weather operations.

Fuel with a low cetane number can be the root cause of problems during cold start.

Viscosity

Viscosity is the property of a liquid of offering resistance to shear or flow. Viscosity decreases with increasing temperature. This decrease in viscosity follows a logarithmic relationship for normal fossil fuel. The common reference is to kinematic viscosity. This is the quotient of the dynamic viscosity that is divided by the density. The determination of kinematic viscosity is normally by readings from gravity flow viscometers at standard temperatures. Refer to "ISO 3104" for the test method.

The viscosity of the fuel is significant because fuel serves as a lubricant for the fuel system components. Fuel must have sufficient viscosity in order to lubricate the fuel system in both cold temperatures and hot temperatures. If the kinematic viscosity of the fuel is lower than 1.4 cSt at the fuel injection pump, damage to the fuel injection pump can occur. This damage can be excessive scuffing and seizure. Low viscosity may lead to difficult hot restarting, stalling, and loss of performance. High viscosity may result in seizure of the pump.

Perkins recommends kinematic viscosities of 1.4 and 4.5 cSt that is delivered to the fuel injection pump. If a fuel with a low viscosity is used, cooling of the fuel may be required to maintain 1.4 cSt or greater viscosity at the fuel injection pump. Fuels with a high viscosity might require fuel heaters in order to lower the viscosity to 4.5 cSt at the fuel injection pump.

Density

Density is the mass of the fuel per unit volume at a specific temperature. This parameter has a direct influence on engine performance and a direct influence on emissions. This influence determines the heat output from a given injected volume of fuel. This parameter is quoted in the following kg/m³ at 15 °C (59 °F).

Perkins recommends a value of density of 841 kg/m³ in order to obtain the correct power output. Lighter fuels are acceptable but these fuels will not produce the rated power.

Sulfur

The level of sulfur is governed by emissions legislations. Regional regulation, national regulations, or international regulations can require a fuel with a specific sulfur limit. The sulfur content of the fuel and the fuel quality must comply with all existing local regulations for emissions.

NOTICE

The **1606A** engine models can operate with higher sulfur fuels above 500 PPM (mg/kg) or 0.05% mass. The **1606D** engine models have been developed to operate with LSD. By using the test methods "ASTM D5453, ASTM D2622, or ISO 20846 ISO 20884", the content of sulfur in LSD fuel must be below 500 PPM (mg/kg) or 0.05% mass.

In some parts of the world and for some applications, high sulfur fuels above 0.5% by mass might only be available. Fuel with a high sulfur content can cause engine wear. High sulfur fuel will have a negative impact on emissions of particulates. High sulfur fuel can be used if the local emissions legislation will allow the use. High sulfur fuel can be used in countries that do not regulate emissions.

When only high sulfur fuels are available, it will be necessary that high alkaline lubricating oil is used, or reduce the oil change interval. Refer to Operation and Maintenance Manual, "Fluid Recommendations (Lubricant Information)" for information on sulfur in fuel.

Lubricity

Lubricity is the capability of the fuel to prevent pump wear. The lubricity of the fluid describes the ability of the fluid to reduce the friction between surfaces that are under load. This ability reduces the damage that is caused by friction. Fuel injection systems rely on the lubricating properties of the fuel. Until fuel sulfur limits were mandated, the lubricity of the fuel was believed to be a function of fuel viscosity.

The lubricity has particular significance to the current low viscosity fuel, low sulfur fuel, and low aromatic fossil fuel. These fuels are made in order to meet stringent exhaust emissions.

The lubricity of these fuels must not exceed wear scar diameter of 0.46 mm (0.01811 inch). The fuel lubricity test must be performed on an HFRR, operated at 60 °C (140 °F). Refer to "ISO 12156-1".

NOTICE

The fuels system has been qualified with fuel having lubricity up to 0.46 mm (0.01811 inch) wear scar diameter as tested by "ISO 12156-1". Fuel with higher wear scar diameter than 0.46 mm (0.01811 inch) will lead to reduced service life and premature failure of the fuel system.

In case of the fuels which do not meet specified lubricity requirement appropriate lubricity additive can be used to enhance the lubricity of the fuel.

Contact your fuel supplier for those circumstances when fuel additives are required. Your fuel supplier can make recommendations for additives to use and for the proper level of treatment.

Distillation

Distillation is an indication of the mixture of different hydrocarbons in the fuel. A high ratio of light weight hydrocarbons can affect the characteristics of combustion.

Classification of the Fuels

Diesel engines have the ability to burn wide variety of fuels. Below is a list of typically encountered fuel specifications that have been assessed as to their acceptability and are divided into following categories:

Group 1: Preferred Fuels

The following fuel specifications are considered acceptable.

Fuels meeting the requirements that are listed in the table 13 .

"EN590 - Grades A to F and class 0 to 4"

"ASTM D975 Grade No. 1-D and 2-D"

"JIS K2204 Grades 1, 2 & 3 & Special Grade 3" acceptable provided lubricity wear scar diameter does not exceed of 0.46 mm (0.01811 inch) as per "ISO 12156-1" .

"BS2869 - Class A2 Off Highway Gas Oil, Red Diesel"

Note: The lubricity of these fuels must not exceed wear scar diameter of 0.46 mm (0.01811 inch) as per "ISO 12156-1" . Refer to "Lubricity".

Group 2: Aviation Kerosene Fuels

Following kerosene and jet fuel specifications are acceptable alternative fuels and may be used on a contingency bases, for emergency or continuous use, where standard diesel fuel is not available and where legislation allows their use:

"MIL-DTL-83133 NATO F34 (JP-8)"

"MIL-DTL-83133 NATO F35"

"MIL-DTL-5624 NATO F44 (JP-5)"

"MIL-DTL-38219 (USAF) (JP7)"

"NATO XF63"

"ASTM D1655 JET A"

"ASTM D1655 JET A1"

NOTICE

These fuels are only acceptable when used with appropriate lubricity additive and must meet minimum requirements that are listed in table 13 . The lubricity of these fuels must not exceed wear scar diameter of 0.46 mm (0.01811 inch) as per "ISO 12156-1" . Refer to "Lubricity".

Note: Minimum cetane number of 40 is recommended otherwise cold starting problems or light load misfire might occur. Since jet fuel specifications do not mention cetane requirements, Perkins recommends that a fuel sample is taken to determine the cetane number.

Note: Fuels must have minimum viscosity of 1.4 cSt delivered to the fuel injection pump. Cooling of the fuel may be required to maintain 1.4 cSt or greater viscosity at the fuel injection pump. Perkins recommends that the actual viscosity of the fuel be measured in order to determine if a fuel cooler is needed. Refer to "Viscosity".

Note: Rated power loss of up to 10 percent is possible due to lower density and lower viscosity of jet fuels compared to diesel fuels.

Biodiesel Fuel

Biodiesel is a fuel that can be defined as mono-alkyl esters of fatty acids. Biodiesel is a fuel that can be made from various feedstock. The most commonly available biodiesel in Europe is Rape Methyl Ester (REM). This biodiesel is derived from rapeseed oil. Soy Methyl Ester (SME) is the most common biodiesel in the United States. This biodiesel is derived from soybean oil. Soybean oil or rapeseed oil are the primary feedstocks. These fuels are together known as Fatty Acid Methyl Esters (FAME).

Raw pressed vegetable oils are NOT acceptable for use as a fuel in any concentration in compression engines. Without esterification, oil will gel in the crankcase and the fuel tank. These fuels may not be compatible with many of the elastomers that are used in engines that are manufactured today. In original forms, these oils are not suitable for use as a fuel in compression engines. Alternate base stocks for biodiesel may include animal tallow, waste cooking oils, or various other feedstocks. In order to use any of the products that are listed as fuel, the oil must be esterified.

Fuel made of 100 percent FAME is generally referred to as B100 biodiesel or neat biodiesel.

Biodiesel can be blended with distillate diesel fuel. The blends can be used as fuel. The most commonly available biodiesel blends are B5, which is 5 percent biodiesel and 95 percent distillate diesel fuel. B20, which is 20 percent biodiesel and 80 percent distillate diesel fuel.

Note: The percentages given are volume-based. The U.S. distillate diesel fuel specification "ASTM D975-09a" includes up to B5 (5 percent) biodiesel.

European distillate diesel fuel specification "EN590:2010" includes up to B7 (7 percent) biodiesel.

Note: Engines that are manufactured by Perkins are certified by use of the prescribed Environmental Protection Agency (EPA) and European Certification fuels. Perkins does not certify engines on any other fuel. The user of the engine has the responsibility of using the correct fuel that is recommended by the manufacturer and allowed by the EPA and other appropriate regulatory agencies.

Specification Requirements

The neat biodiesel must conform to "EN14214" or "ASTM D6751" (in the USA) and can only be blended in mixture of up to 20% by volume in acceptable mineral diesel fuel meeting requirements that are listed in table 13 or the latest edition of "EN590" and "ASTM D 975" commercial standards. This blend is commonly known as B20.

Biodiesel blends are denoted as "BXX" with "XX" representing the content of neat biodiesel contained in the blend with mineral diesel fuel (for example B5, B10, B20).

In United States Biodiesel blends of B6 to B20 must meet the requirements listed in the latest edition of "ASTM D7467" (B6 to B20) and must be of an API gravity of 30-45.

In North America biodiesel and biodiesel blends must be purchased from the BQ-9000 accredited producers and BQ-9000 certified distributors.

In other areas of the world, the use of biodiesel that is BQ-9000 accredited and certified, or that is accredited and certified by a comparable biodiesel quality body to meet similar biodiesel quality standards is required.

Engine Service Requirements with B20

Aggressive properties of biodiesel fuel may cause debris in the fuel tank and fuel lines. The aggressive properties of biodiesel will clean the fuel tank and fuel lines. This cleaning of the fuel system can prematurely block of the fuel filters. Perkins recommends that after the initial usage of B20 biodiesel blended fuel the fuel filters must be replaced at 50 hours.

Glycerides present in biodiesel fuel will also cause fuel filters to become blocked more quickly. Therefore the regular service interval should be reduced to 250 hours.

When biodiesel fuel is used, crank case oil and aftertreatment systems may be influenced. This influence is due to the chemical composition and characteristics of biodiesel fuel, such as density and volatility, and to chemical contaminants that can be present in this fuel, such as alkali and alkaline metals (sodium, potassium, calcium, and magnesium).

- Crankcase oil fuel dilution can be higher when biodiesel or biodiesel blends are used. This increased level of fuel dilution when using biodiesel or biodiesel blends is related to the typically lower volatility of biodiesel. In-cylinder emissions control strategies utilized in many of the industrial latest engine designs may lead to a higher level of biodiesel concentration in the engine oil pan. The long-term effect of biodiesel concentration in crankcase oil is currently unknown.
- Perkins recommends the use of oil analysis in order to check the quality of the engine oil if biodiesel fuel is used. Ensure that the level of biodiesel in the fuel is noted when the oil sample is taken.

Performance Related Issues with B20

Due to the lower energy content than the standard distillate fuel B20 will cause a power loss in order of 2 to 4 percent. In addition, over time the power may deteriorate further due to deposits in the fuel injectors.

Biodiesel and biodiesel blends are known to cause an increase in fuel system deposits, most significant of which are deposits within the fuel injector. These deposits can cause a loss in power due to restricted or modified fuel injection or cause other functional issues associated with these deposits.

Note: Perkins T400012 Fuel Cleaner is most effective in cleaning and preventing the formation of deposits. Perkins Diesel Fuel Conditioner helps to limit deposit issues by improving the stability of biodiesel and biodiesel blends. Refer to “Perkins Diesel Fuel System Cleaner, and Perkins” for more information.

General Requirements

Biodiesel has poor oxidation stability, which can result in long-term problems in the storage of biodiesel. Biodiesel fuel should be used within 6 months of manufacture. Equipment should not be stored with the B20 biodiesel blends in the fuel system for longer than 3 months.

Due to poor oxidation stability and other potential issues, it is strongly recommended that engines with limited operational time either not use B20 biodiesel blends or, while accepting some risk, limit biodiesel blend to a maximum of B5. Examples of applications that should limit the use of biodiesel are the following: Standby generator sets and certain emergency vehicles.

Perkins strongly recommends that seasonally operated engines have the fuel systems, including fuel tanks, flashed with conventional diesel fuel before prolonged shutdown periods. An example of an application that should seasonally flush the fuel system is a combine harvester.

Microbial contamination and growth can cause corrosion in the fuel system and premature plugging of the fuel filter. Consult your supplier of fuel for assistance in selecting appropriate antimicrobial additive.

Water accelerates microbial contamination and growth. When biodiesel is compared to distillate fuels, water is naturally more likely to exist in the biodiesel. Therefore essential to check frequently and if necessary, drain the water separator.

Materials such as brass, bronze, copper, lead, tin, and zinc accelerate the oxidation process of the biodiesel fuel. The oxidation process can cause deposits formation therefore these materials must not be used for fuel tanks and fuel lines.

Fuel for Cold Weather Operation

The European standard “EN590” contains climate dependant requirements and a range of options. The options can be applied differently in each country. There are five classes that are given to arctic climates and severe winter climates. 0, 1, 2, 3 and 4.

Fuel that complies with “EN590 ” CLASS 4 can be used at temperatures as low as $-44\text{ }^{\circ}\text{C}$ ($-47.2\text{ }^{\circ}\text{F}$). Refer to “EN590” for a detailed discretion of the physical properties of the fuel.

The diesel fuel “ASTM D975 1-D” used in the United States of America may be used in cold temperatures that are below $-18\text{ }^{\circ}\text{C}$ ($-0.4\text{ }^{\circ}\text{F}$).

In extreme cold ambient conditions, you may use Aviation, kerosene fuels specified in the section Group 2 Aviation Kerosene Fuels. These fuels are intended to be used in temperatures that can be as low as $-54\text{ }^{\circ}\text{C}$ ($-65.2\text{ }^{\circ}\text{F}$). Refer to the section Group 2 Aviation Kerosene Fuels for detail and conditions of use.

WARNING

Mixing alcohol or gasoline with diesel fuel can produce an explosive mixture in the engine crankcase or the fuel tank. Alcohol or gasoline must not be used in order to dilute diesel fuel. Failure to follow this instruction may result in death or personal injury.

There are many other diesel fuel specifications that are published by governments and by technological societies. Usually, those specifications do not review all the requirements that are addressed in table 13 . To ensure optimum engine performance, a complete fuel analysis should be obtained before engine operation. The fuel analysis should include all of the properties that are stated in the table 13 .

Aftermarket Fuel Additives

NOTICE

Perkins does not warrant the quality or performance of non-Perkins fluids and filters.

When auxiliary devices, accessories, or consumables (filters, additives) which are made by other manufacturers are used on Perkins products, the Perkins warranty is not affected simply because of such use.

However, failures that result from the installation or use of other manufacturers devices, accessories, or consumables are NOT Perkins defects. Therefore, the defects are NOT covered under the Perkins warranty.

Supplemental diesel fuel additives are not recommended. This is due to potential damage to the fuel system or the engine. Your fuel supplier or the fuel manufacturer will add the appropriate supplemental diesel fuel additives.

Perkins recognizes the fact that additives may be required in some special circumstances. Fuel additives need to be used with caution. Contact your fuel supplier for those circumstances when fuel additives are required. Your fuel supplier can recommend the appropriate fuel additive and the correct level of treatment.

Note: For the best results, your fuel supplier should treat the fuel when additives are required. The treated fuel must meet the requirements that are stated in table 13 .

Perkins Diesel Fuel System Cleaner

Perkins T400012 Fuel Cleaner is the only fuel cleaner that is recommended by Perkins.

If biodiesel or biodiesel blends of fuel are to be used, Perkins require the use of Perkins fuel cleaner. For more information on the use of biodiesel and biodiesel blends refer to "Biodiesel Fuel".

Perkins fuel cleaner will remove deposits that can form in the fuel system with the use of biodiesel and biodiesel blends. These deposits can create a loss of power and engine performance.

Once the fuel cleaner has been added to the fuel, the deposits within the fuel system are removed after 30 hours of engine operation. For maximum results, continue to use the fuel cleaner for up to 80 hours. Perkins fuel cleaner can be used on an on-going basis with no adverse impact on engine or fuel system durability.

Detailed instructions on the rate of which the fuel cleaner must be use are on the container.

Maintenance Recommendations

i04268553

System Pressure Release

Coolant System

WARNING

Pressurized system: Hot coolant can cause serious burn. To open cap, stop engine, wait until radiator is cool. Then loosen cap slowly to relieve the pressure.

The engine can have the ability to auto start. Ensure that the power supply is isolated before any service or repair is performed.

To relieve the pressure from the coolant system, turn off the engine. Allow the cooling system pressure cap to cool. Remove the cooling system pressure cap slowly in order to relieve pressure.

Fuel System

To relieve the pressure from the fuel system, turn off the engine.

High Pressure Line for Fuel Injectors

The high-pressure line is between the high-pressure pump and the high-pressure manifold within the cylinder head. The line is different from pressure lines on other systems.

The high-pressure line is different for the following reasons:

- The high-pressure line is constantly charged with high-pressure fluid.
- The internal pressures of the high-pressure lines are higher than other types of system.

Before any service or repair is performed on the engine lines, perform the following tasks:

1. Stop the engine.
2. Wait for 10 minutes.

Do not loosen the high-pressure line in order to remove air from the system.

Engine Oil

To relieve pressure from the lubricating system, turn off the engine.

i04268569

Welding on Engines with Electronic Controls

NOTICE

Because the strength of the frame may decrease, some manufacturers do not recommend welding onto a chassis frame or rail. Consult the OEM of the equipment or your Perkins dealer regarding welding on a chassis frame or rail.

Proper welding procedures are necessary in order to avoid damage to the engines ECM, sensors, and associated components. When possible, remove the component from the unit and then weld the component. If removal of the component is not possible, the following procedure must be followed when you weld on a unit equipped with an Electronic Engine. The following procedure is considered to be the safest procedure to weld on a component. This procedure should provide a minimum risk of damage to electronic components.

NOTICE

Do not ground the welder to electrical components such as the ECM or sensors. Improper grounding can cause damage to the drive train bearings, hydraulic components, electrical components, and other components.

Clamp the ground cable from the welder to the component that will be welded. Place the clamp as close as possible to the weld. This will help reduce the possibility of damage.

Note: Perform the welding in areas that are free from explosive hazards.

1. Stop the engine. Turn the switched power to the OFF position.
2. Ensure that the fuel supply to the engine is turned off.
3. Disconnect the negative battery cable from the battery. If a battery disconnect switch is provided, open the switch.
4. Disconnect all electronic components from the wiring harnesses. Include the following components:

Maintenance Section
Severe Service Application

- Electronic components for the driven equipment
- ECM
- Sensors
- Electronically controlled valves
- Relays

NOTICE

Do not use electrical components (ECM or ECM sensors) or electronic component grounding points for grounding the welder.

5. Connect the welding ground cable directly to the part that will be welded. Place the ground cable as close as possible to the weld in order to reduce the possibility of welding current damage to the following components. Bearings, hydraulic components, electrical components, and ground straps.

Note: If electrical/electronic components are used as a ground for the welder, or electrical/electronic components are located between the welder ground and the weld, current flow from the welder could severely damage the component.

6. Protect the wiring harness from welding debris and spatter.
7. Use standard welding practices to weld the materials.

i04150276

Severe Service Application

Severe service is the application of an engine that exceeds the current published standards for that engine. Perkins maintains standards for the following engine parameters:

- Performance such as power range, speed range, and fuel consumption
- Fuel quality
- Operational Altitude
- Maintenance intervals
- Oil selection and maintenance
- Coolant type and maintenance
- Environmental qualities
- Installation
- The temperature of the fluid in the engine

Refer to the standards for the engine or consult your Perkins dealer or your Perkins distributor in order to determine if the engine is operating within the defined parameters.

Severe service operation can accelerate component wear. Engines that operate under severe conditions may need more frequent maintenance intervals in order to ensure maximum reliability and retention of full service life.

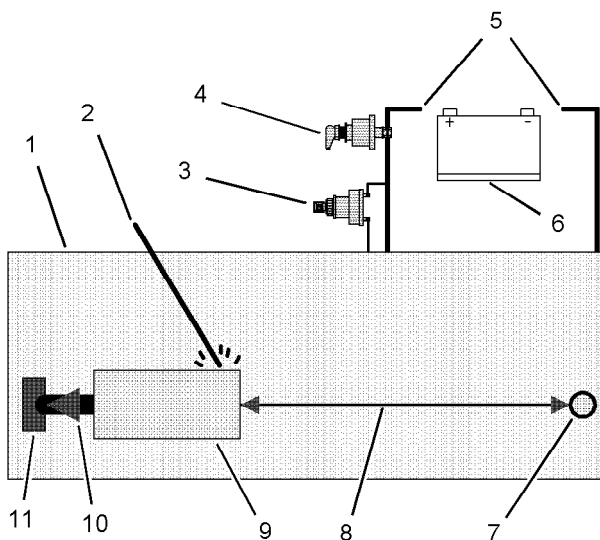

Illustration 35

g01075639

Use the example above. The current flow from the welder to the ground clamp of the welder will not damage any associated components.

- (1) Engine
- (2) Welding electrode
- (3) Keyswitch in the OFF position
- (4) Battery disconnect switch in the open position
- (5) Disconnected battery cables
- (6) Battery
- (7) Electrical/Electronic component
- (8) Minimum distance between the component that is being welded and any electrical/electronic component
- (9) The component that is being welded
- (10) Current path of the welder
- (11) Ground clamp for the welder

Due to individual applications, it is not possible to identify all of the factors which can contribute to severe service operation. Consult your Perkins dealer or your Perkins distributor for the unique maintenance that is necessary for the engine.

The operating environment, incorrect operating procedures, and incorrect maintenance procedures can be factors which contribute to a severe service application.

Environmental Factors

Ambient temperatures – The engine may be exposed to extended operation in cold environments or hot environments. Valve components can be damaged by carbon buildup if the engine is frequently started and stopped in cold temperatures. Hot intake air reduces engine performance.

Quality of the air – The engine may be exposed to extended operation in an environment that is dirty or dusty, unless the equipment is cleaned regularly. Mud, dirt, and dust can encase components. Maintenance can be difficult. The buildup can contain corrosive chemicals.

Buildup – Compounds, elements, corrosive chemicals, and salt can damage some components.

Altitude – Problems can arise when the engine is operated at altitudes that are higher than the intended settings for that application. Necessary adjustments should be made.

Incorrect Operating Procedures

- Extended operation at low idle
- Frequent hot shutdowns
- Operating at excessive loads
- Operating at excessive speeds
- Operating outside the intended application

Incorrect Maintenance Procedures

- Extending the maintenance intervals
- Failure to use recommended fuel, lubricants, and coolant/antifreeze

i04268574

Maintenance Interval Schedule

Note: The oil and filter change period for the 1606A engine is different to the 1606D engine. The 1606A engine is 500 hours and the 1606D engine is 400 hours.

Note: Ensure that table 1 is referred to in the information in This Manual, "Engine Valve Lash - Check", in order to select the correct maintenance interval schedule.

When Required

" Battery - Replace"	68
" Battery or Battery Cable - Disconnect"	69
" Engine - Clean"	76
" Fuel System - Prime"	82

Daily

" Coolant Level - Check"	74
" Driven Equipment - Check"	76
" Engine Air Cleaner Service Indicator - Inspect"	77
" Engine Air Precleaner - Check/Clean"	77
" Engine Oil Level - Check"	77
" Fuel System Water Separator - Check/Drain"	84
"Walk-Around Inspection"	88

Every 250 Service Hours or 1 Year

" Battery Electrolyte Level - Check"	69
" Fuel Tank Water and Sediment - Drain"	85

Every 400 Service Hours

" Engine Oil and Filter - Change"	80
---	----

Every 500 Service Hours

" Belt - Inspect"	70
" Engine Air Cleaner Element (Single Element) - Inspect/Clean/Replace"	76
" Engine Oil and Filter - Change"	78
" Engine Valve Lash - Check"	80

" Fan Clearance - Check"	81
" Fuel System Primary Filter - Clean/Inspect/Replace"	83
" Fuel System Secondary Filter - Replace"	84

Every 500 Service Hours or 1 Year

" Aftercooler Core - Inspect/Clean/Test"	67
" Cooling System Supplemental Coolant Additive (SCA) - Test/Add"	74
" Hoses and Clamps - Inspect/Replace"	85
" Radiator - Clean"	86

Every 2000 Service Hours

" Engine Mounts - Inspect"	77
" Starting Motor - Inspect"	87
" Turbocharger - Inspect"	87

Every 3000 Service Hours

" Alternator - Inspect"	67
" Alternator and Fan Belts - Replace"	68
" Belt Tensioner - Check"	70
" Crankshaft Vibration Damper - Inspect"	75
" Water Pump - Inspect"	89

Every 3000 Service Hours or 2 Years

" Coolant (Commercial Heavy-Duty) - Change" ..	70
--	----

Every 6000 Service Hours or 3 Years

" Coolant (ELC) - Change"	72
---------------------------------	----

Commissioning

" Fan Clearance - Check"	81
--------------------------------	----

i04272910

i02322311

Aftercooler Core - Inspect/ Clean/Test

Note: Adjust the frequency of cleaning according to the effects of the operating environment.

Inspect the cooling air side of the aftercooler for these items: damaged fins, corrosion, dirt, grease, insects, leaves, oil and other debris. Clean the cooling air side of the aftercooler, if necessary.

For air-to-air aftercoolers, use the same methods that are used for cleaning the outside of radiators.

WARNING

Personal injury can result from air pressure.

Personal injury can result without following proper procedure. When using pressure air, wear a protective face shield and protective clothing.

Maximum air pressure at the nozzle must be less than 205 kPa (30 psi) for cleaning purposes.

Pressurized air is the preferred method for removing loose debris. Hold the nozzle approximately 6 mm (0.25 inch) away from the fins. Slowly move the air nozzle in a direction that is parallel with the tubes. This will remove debris that is between the tubes.

Pressurized water may also be used for cleaning. The maximum water pressure for cleaning purposes must be less than 275 kPa (40 psi). Use pressurized water in order to soften mud.

Use a degreaser and steam for removal of oil and grease. Wash the core with detergent and hot water. Thoroughly rinse the core with clean water.

After cleaning, start the engine. Run the engine for 2 minutes. Operating the engine will help in the removal of debris and drying of the core. Stop the engine. Inspect the core for cleanliness. Repeat the cleaning, if necessary.

Inspect the fins for damage. Bent fins may be opened with a "comb".

Inspect these items for good condition: welds, mounting brackets, air lines, connections, clamps and seals. Make repairs, if necessary.

Alternator - Inspect

Perkins recommends a scheduled inspection of the alternator. Inspect the alternator for loose connections and correct battery charging. Check the ammeter (if equipped) during engine operation in order to ensure correct battery performance and/or correct performance of the electrical system. Make repairs, as required.

Check the alternator and the battery charger for correct operation. If the batteries are correctly charged, the ammeter reading should be very near zero. All batteries should be kept charged. The batteries should be kept warm because temperature affects the cranking power. If the battery is too cold, the battery will not crank the engine. When the engine is not run for long periods of time or if the engine is run for short periods, the batteries may not fully charge. A battery with a low charge will freeze more easily than a battery with a full charge.

i04766049

i01878164

Alternator and Fan Belts - Replace

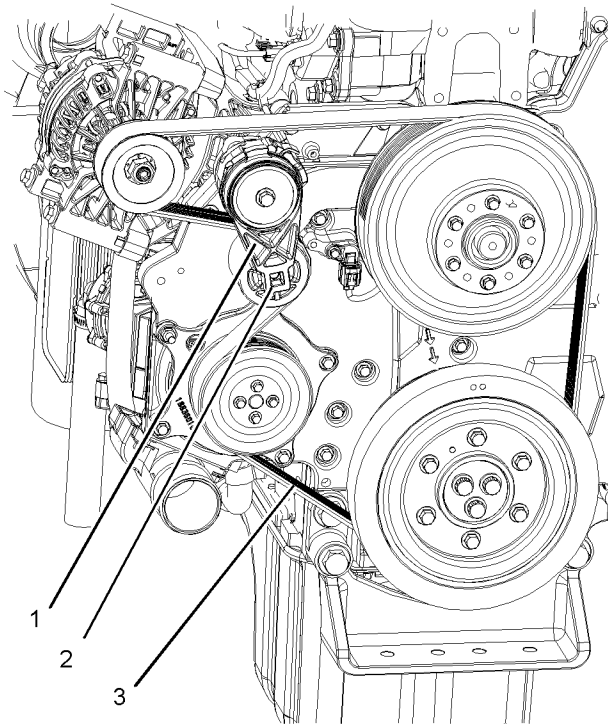

Illustration 36

g02862817

Typical example

Ensure that the battery disconnect switch is in the off position. Remove the fan guards, refer to OEM.

Install a suitable tool into the half inch square hole (2). Rotate tensioner (1) clockwise in order to release tension on the belt (3). With all the tension removed from the belt, remove the belt from the engine.

Note: With the belt removed all the pulleys bearing and the tensioner should be checked for wear or damage.

Install the belt on to the pulleys. Install a suitable tool into the tensioner. Rotate the tensioner in order to allow installation of the belt. Install the belt over all the pulleys and slowly release the tensioner. Check that the belt is correctly installed on the pulleys.

Install the fan guards, refer to OEM.

Battery - Replace

WARNING

Batteries give off combustible gases which can explode. A spark can cause the combustible gases to ignite. This can result in severe personal injury or death.

Ensure proper ventilation for batteries that are in an enclosure. Follow the proper procedures in order to help prevent electrical arcs and/or sparks near batteries. Do not smoke when batteries are serviced.

WARNING

The battery cables or the batteries should not be removed with the battery cover in place. The battery cover should be removed before any servicing is attempted.

Removing the battery cables or the batteries with the cover in place may cause a battery explosion resulting in personal injury.

1. Switch the engine to the OFF position. Remove all electrical loads.
2. Turn off any battery chargers. Disconnect any battery chargers.
3. The NEGATIVE “-” cable connects the NEGATIVE “-” battery terminal to the NEGATIVE “-” terminal on the starter motor. Disconnect the cable from the NEGATIVE “-” battery terminal.
4. The POSITIVE “+” cable connects the POSITIVE “+” battery terminal to the POSITIVE “+” terminal on the starting motor. Disconnect the cable from the POSITIVE “+” battery terminal.

Note: Always recycle a battery. Never discard a battery. Return used batteries to an appropriate recycling facility.

5. Remove the used battery.
6. Install the new battery.

Note: Before the cables are connected, ensure that the engine start switch is OFF.

7. Connect the cable from the starting motor to the POSITIVE “+” battery terminal.

8. Connect the cable from the NEGATIVE “-” terminal on the starter motor to the NEGATIVE “-” battery terminal.

i02563861

Battery Electrolyte Level - Check

When the engine is not run for long periods of time or when the engine is run for short periods, the batteries may not fully recharge. Ensure a full charge in order to help prevent the battery from freezing. If batteries are correctly charged, the ammeter reading should be very near zero, when the engine is in operation.

WARNING

All lead-acid batteries contain sulfuric acid which can burn the skin and clothing. Always wear a face shield and protective clothing when working on or near batteries.

1. Remove the filler caps. Maintain the electrolyte level to the “FULL” mark on the battery.

If the addition of water is necessary, use distilled water. If distilled water is not available use clean water that is low in minerals. Do not use artificially softened water.

2. Check the condition of the electrolyte with a suitable battery tester.
3. Install the caps.
4. Keep the batteries clean.

Clean the battery case with one of the following cleaning solutions:

- A mixture of 0.1 kg (0.2 lb) of washing soda or baking soda and 1 L (1 qt) of clean water
- A mixture of 0.1 L (0.11 qt) of ammonia and 1 L (1 qt) of clean water

Thoroughly rinse the battery case with clean water.

Use a fine grade of sandpaper to clean the terminals and the cable clamps. Clean the items until the surfaces are bright or shiny. DO NOT remove material excessively. Excessive removal of material can cause the clamps to not fit properly. Coat the clamps and the terminals with a suitable petroleum jelly.

i08246088

Battery or Battery Cable - Disconnect

WARNING

The battery cables or the batteries should not be removed with the battery cover in place. The battery cover should be removed before any servicing is attempted.

Removing the battery cables or the batteries with the cover in place may cause a battery explosion resulting in personal injury.

1. Turn the start switch to the OFF position. Turn the ignition switch (if equipped) to the OFF position and remove the key and all electrical loads.
2. Turn off any battery chargers. Disconnect any battery chargers.
3. Disconnect the negative battery terminal at the battery that goes to the start switch. Ensure that the cable cannot contact the terminal. When four 12 volt batteries are involved, the negative side of two batteries must be disconnected.
4. Tape the leads to help prevent accidental starting.
5. Proceed with necessary system repairs. Reverse the steps to reconnect all cables.

i04633290

Belt Tensioner - Check

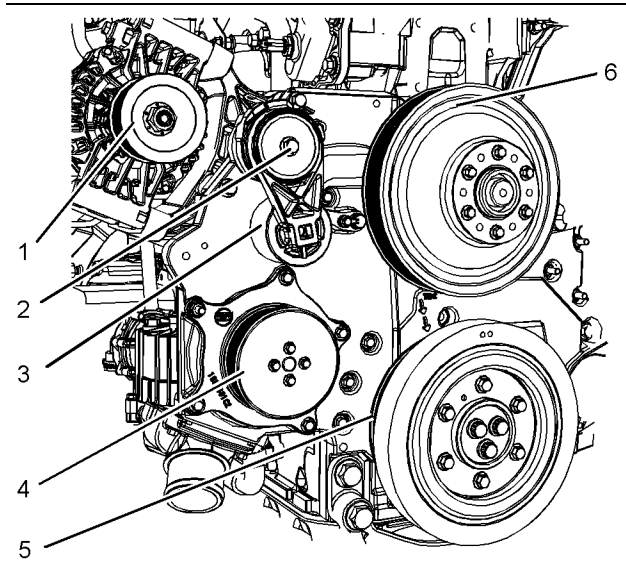

Illustration 37

g02778118

Typical example

1. Remove belt, refer to this Operation and Maintenance Manual, "Alternator and Fan Belts-Replace".
2. With the belt removed check the alternator pulley (1), the fan pulley (6), and water pump pulley (4). Ensure that all these pulleys rotated freely. Ensure that all pulleys are clean and free from damage including the crankshaft pulley (5).
3. Check the pulley (3) on the tensioner. Ensure that the pulley can rotate freely. Check the bearing for lateral movement.
4. Check the securing bolt (2). The torque for the bolt is 50 N·m (37 lb ft).

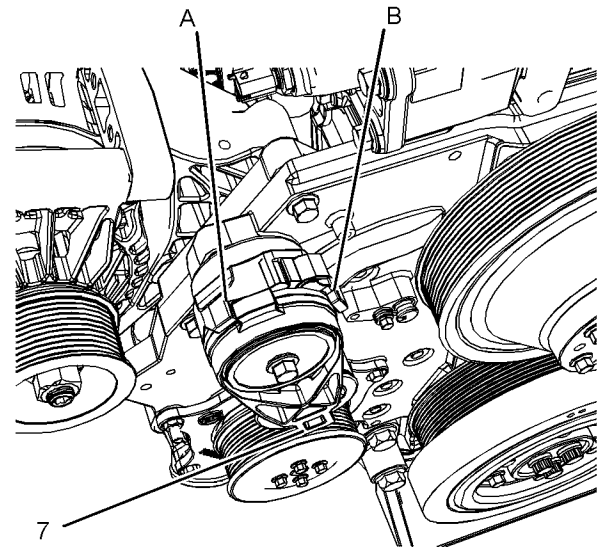

Illustration 38

g02865556

Typical example

5. Install a suitable tool into the half inch square hole (7). Rotate the tensioner between the point (A) and point (B). Ensure that there is an even resistance when rotating between the two travel points.

Replace parts as necessary, for replacing the tensioner. Refer to Disassembly and Assembly, "Belt Tensioner - Remove and Install".

i04766012

Belt - Inspect

Inspect the belt for wear, cracks, spites, grease, damage to the cord, or fluid contamination.

i04269949

Coolant (Commercial Heavy-Duty) - Change

NOTICE

Care must be taken to ensure that fluids are contained during performance of inspection, maintenance, testing, adjusting and repair of the product. Be prepared to collect the fluid with suitable containers before opening any compartment or disassembling any component containing fluids.

Dispose of all fluids according to Local regulations and mandates.

NOTICE

Keep all parts clean from contaminants.

Contaminants may cause rapid wear and shortened component life.

Clean the cooling system and flush the cooling system before the recommended maintenance interval if the following conditions exist:

- The engine overheats frequently.
- Foaming of the coolant is observed.
- The oil has entered the cooling system and the coolant is contaminated.
- The fuel has entered the cooling system and the coolant is contaminated.

Note: When the cooling system is cleaned, only clean water is needed.

NOTICE

When any servicing or repair of the engine cooling system is performed the procedure must be performed with the engine on level ground. This will allow you to accurately check the coolant level. This will also help in avoiding the risk of introducing an air lock into the coolant system.

Drain**WARNING**

Pressurized System: Hot coolant can cause serious burns. To open the cooling system filler cap, stop the engine and wait until the cooling system components are cool. Loosen the cooling system pressure cap slowly in order to relieve the pressure.

1. Stop the engine and allow the engine to cool. Loosen the cooling system filler cap slowly in order to relieve any pressure. Remove the cooling system filler cap.

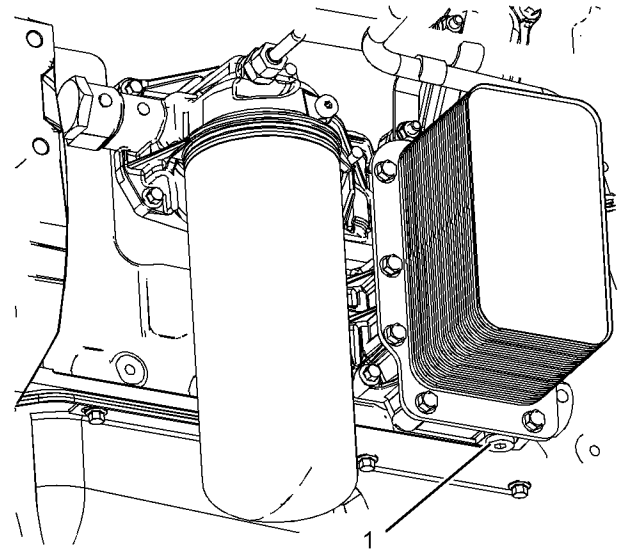

Illustration 39

g02439857

2. Open the drain cock or remove the drain plug (1).

Allow the coolant to drain.

NOTICE

Dispose of used engine coolant or recycle. Various methods have been proposed to reclaim used coolant for reuse in engine cooling systems. The full distillation procedure is the only method acceptable by Perkins to reclaim the coolant.

For information regarding the disposal and the recycling of used coolant, consult your Perkins dealer or your Perkins distributor.

Flush

1. Flush the cooling system with clean water in order to remove any debris.
2. Close the drain plug (1). Close the drain cock or install the drain plug on the radiator.

NOTICE

Do not fill the cooling system faster than 5 L (1.3 US gal) per minute, in order to avoid air locks.

Cooling system air locks may result in engine damage.

3. Fill the cooling system with clean water. Install the cooling system filler cap.
4. Start and run the engine at low idle until the temperature reaches 49 to 66 °C (120 to 150 °F).

5. Stop the engine and allow the engine to cool. Loosen the cooling system filler cap slowly in order to relieve any pressure. Remove the cooling system filler cap. Open the drain cock or remove the drain plug on the engine. Open the drain cock or remove the drain plug on the radiator. Allow the water to drain. Flush the cooling system with clean water.

Fill

1. Close the drain plug (1). Close the drain cock or install the drain plug on the radiator.

NOTICE

Do not fill the cooling system faster than 5 L (1.3 US gal) per minute, in order to avoid air locks.

Cooling system air locks may result in engine damage.

2. Fill the cooling system with Commercial Heavy-Duty Coolant. Add Supplemental Coolant Additive to the coolant. For the correct amount, refer to the Operation and Maintenance Manual, "Fluid Recommendations" topic (Maintenance Section) for more information on cooling system specifications. Do not install the cooling system filler cap.
 3. Start and run the engine at low idle. Increase the engine rpm to high idle. Operate the engine in order to open the engine thermostat. This procedure will allow any air in the system to be purged. Decrease the engine speed to low idle. Stop the engine.
 4. Maintain the coolant level at the maximum mark that is correct for your application.
-

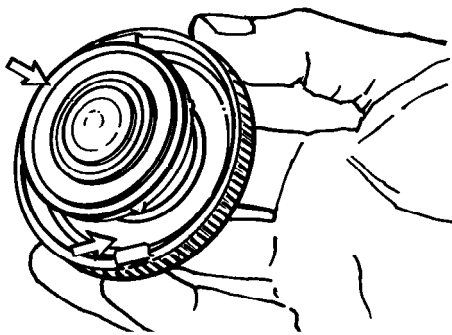

Illustration 40
Filler cap

g00103639

5. Clean the cooling system filler cap and inspect the gasket. If the gasket is damaged, discard the old filler cap and install a new filler cap. If the gasket is not damaged, use a suitable pressurizing pump in order to pressure test the filler cap. The correct pressure is stamped on the face of the filler cap. If the filler cap does not retain the correct pressure, install a new filler cap.
6. Start the engine. Inspect the cooling system for leaks and for correct operating temperature.

i04269950

Coolant (ELC) - Change

NOTICE

Care must be taken to ensure that fluids are contained during performance of inspection, maintenance, testing, adjusting and repair of the product. Be prepared to collect the fluid with suitable containers before opening any compartment or disassembling any component containing fluids.

Dispose of all fluids according to Local regulations and mandates.

NOTICE

Keep all parts clean from contaminants.

Contaminants may cause rapid wear and shortened component life.

Clean the cooling system and flush the cooling system before the recommended maintenance interval if the following conditions exist:

- The engine overheats frequently.
- Foaming of the coolant is observed.
- The oil has entered the cooling system and the coolant is contaminated.
- The fuel has entered the cooling system and the coolant is contaminated.

Note: When the cooling system is cleaned, only clean water is needed when the ELC is drained and replaced.

Note: Inspect the water pump and the water temperature regulator after the cooling system has been drained. The inspection is a good opportunity to replace the water pump, the water temperature regulator, and the hoses, if necessary.

Drain

WARNING

Pressurized System: Hot coolant can cause serious burns. To open the cooling system filler cap, stop the engine and wait until the cooling system components are cool. Loosen the cooling system pressure cap slowly in order to relieve the pressure.

1. Stop the engine and allow the engine to cool. Loosen the cooling system filler cap slowly in order to relieve any pressure. Remove the cooling system filler cap.
2. Open the drain cock or remove the drain plug on the radiator.
Allow the coolant to drain.

NOTICE

Dispose of used engine coolant or recycle. Various methods have been proposed to reclaim used coolant for reuse in engine cooling systems. The full distillation procedure is the only method acceptable by Perkins to reclaim the coolant.

For information regarding the disposal and the recycling of used coolant, consult your Perkins dealer or your Perkins distributor.

Flush

1. Flush the cooling system with clean water in order to remove any debris.
2. Close the drain cock or install the drain plug on the radiator.

NOTICE

Do not fill the cooling system faster than 5 L (1.3 US gal) per minute to avoid air locks.

Cooling system air locks may result in engine damage.

3. Fill the cooling system with clean water. Install the cooling system filler cap.
4. Start and run the engine until the water temperature regulator opens and the fluid levels decrease in the header tank.

5. Stop the engine and allow the engine to cool. Loosen the cooling system filler cap slowly in order to relieve any pressure. Remove the cooling system filler cap. Open the drain cock or remove the drain plug on the radiator. Allow the water to drain. Flush the cooling system with clean water.

Fill

1. Close the drain cock or install the drain plug on the radiator.

NOTICE

Do not fill the cooling system faster than 5 L (1.3 US gal) per minute to avoid air locks.

Cooling system air locks may result in engine damage.

2. Fill the cooling system with Extended Life Coolant (ELC). Refer to the Operation and Maintenance Manual, "Fluid Recommendations" topic (Maintenance Section) for more information on cooling system specifications. Do not install the cooling system filler cap.
3. Start and run the engine for 1 minute in order to purge the air from the cavities of the engine block. Stop the engine.
4. Check the coolant level. Maintain the coolant level within 13 mm (0.5 inch) below the bottom of the pipe for filling. If necessary, repeat step 3. Maintain the coolant level in the expansion bottle (if equipped) at the correct level.

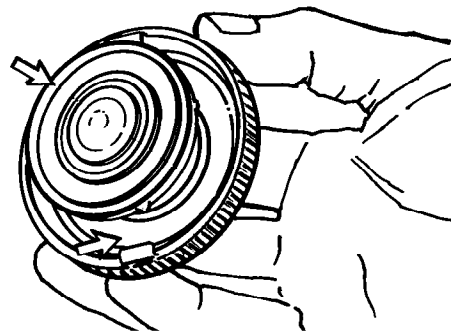

Illustration 41
Filler cap

g00103639

5. Clean the cooling system filler cap and inspect the gasket. If the gasket is damaged, discard the old filler cap and install a new filler cap. If the gasket is not damaged, use a suitable pressurizing pump in order to pressure test the filler cap. The correct pressure is stamped on the face of the filler cap. If the filler cap does not retain the correct pressure, install a new filler cap.
6. Start the engine. Inspect the cooling system for leaks and for correct operating temperature.

i04272912

Coolant Level - Check

Check the coolant level when the engine is stopped and cool.

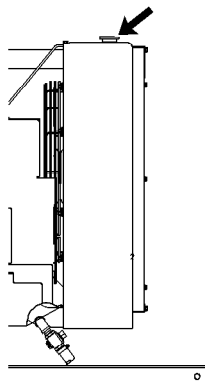

Illustration 42

g00285520

Cooling system filler cap

⚠ WARNING

Pressurized System: Hot coolant can cause serious burns. To open the cooling system filler cap, stop the engine and wait until the cooling system components are cool. Loosen the cooling system pressure cap slowly in order to relieve the pressure.

1. Remove the cooling system filler cap slowly in order to relieve pressure.
2. Maintain the coolant level within 13 mm (0.5 inch) of the bottom of the filler pipe. If the engine is equipped with a sight glass, maintain the coolant level to the proper level in the sight glass.

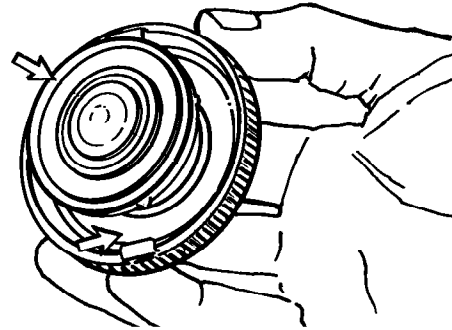

Illustration 43

g00103639

Typical filler cap gaskets

3. Clean the cooling system filler cap and check the condition of the filler cap gaskets. Replace the cooling system filler cap if the filler cap gaskets are damaged. Reinstall the cooling system filler cap.
4. Inspect the cooling system for leaks.

i03644948

Cooling System Supplemental Coolant Additive (SCA) - Test/Add

⚠ WARNING

Cooling system coolant additive contains alkali. To help prevent personal injury, avoid contact with the skin and the eyes. Do not drink cooling system coolant additive.

Test for SCA Concentration

Heavy-Duty Coolant/Antifreeze and SCA

NOTICE

Do not exceed the recommended six percent supplemental coolant additive concentration.

Use a Coolant Conditioner Test Kit in order to check the concentration of the SCA.

Add the SCA, If Necessary

NOTICE

Do not exceed the recommended amount of supplemental coolant additive concentration. Excessive supplemental coolant additive concentration can form deposits on the higher temperature surfaces of the cooling system, reducing the engine's heat transfer characteristics. Reduced heat transfer could cause cracking of the cylinder head and other high temperature components. Excessive supplemental coolant additive concentration could also result in radiator tube blockage, overheating, and/or accelerated water pump seal wear. Never use both liquid supplemental coolant additive and the spin-on element (if equipped) at the same time. The use of those additives together could result in supplemental coolant additive concentration exceeding the recommended maximum.

WARNING

Pressurized System: Hot coolant can cause serious burns. To open the cooling system filler cap, stop the engine and wait until the cooling system components are cool. Loosen the cooling system pressure cap slowly in order to relieve the pressure.

NOTICE

When any servicing or repair of the engine cooling system is performed the procedure must be performed with the engine on level ground. This will allow you to accurately check the coolant level. This will also help in avoiding the risk of introducing an air lock into the coolant system.

1. Slowly loosen the cooling system filler cap in order to relieve the pressure. Remove the cooling system filler cap.

Note: Always discard drained fluids according to local regulations.

2. If necessary, drain some coolant from the cooling system into a suitable container in order to allow space for the extra SCA.
3. Add the correct amount of SCA. Refer to the Operation and Maintenance Manual, "Refill Capacities and Recommendations" for more information on SCA requirements.

4. Clean the cooling system filler cap and inspect the gasket. If the gasket is damaged, discard the old filler cap and install a new filler cap. If the gasket is not damaged, use a suitable pressurizing pump in order to pressure test the filler cap. The correct pressure is stamped on the face of the filler cap. If the filler cap does not retain the correct pressure, install a new filler cap.

i04751069

Crankshaft Vibration Damper - Inspect

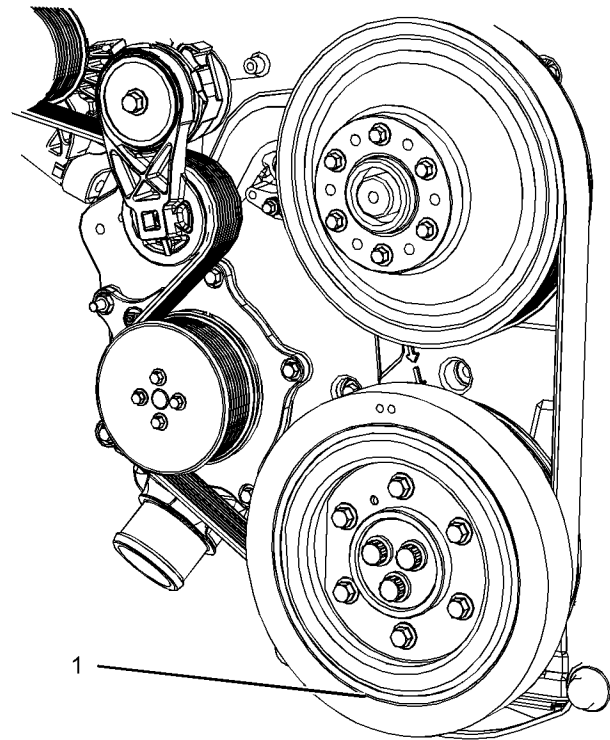

Illustration 44

g02847558

Typical example

Damage to the crankshaft vibration damper or failure of the crankshaft vibration damper can increase torsional vibrations. The torsional vibration can result in damage to the crankshaft and to other engine components. A deteriorating damper can cause excessive gear train noise at variable points in the speed range.

Check the damper for damage and runout. For more information refer to System Operation Testing and Adjusting, "Vibration Damper - Check".

i02151646

i04633632

Driven Equipment - Check

Refer to the OEM specifications for more information on the following maintenance recommendations for the driven equipment:

- Inspection
- Adjustment
- Lubrication
- Other maintenance recommendations

Perform any maintenance for the driven equipment which is recommended by the OEM.

i02568158

Engine - Clean

WARNING

Personal injury or death can result from high voltage.

Moisture can create paths of electrical conductivity.

Make sure that the electrical system is OFF. Lock out the starting controls and tag the controls "DO NOT OPERATE".

NOTICE

Accumulated grease and oil on an engine is a fire hazard. Keep the engine clean. Remove debris and fluid spills whenever a significant quantity accumulates on the engine.

Periodic cleaning of the engine is recommended. Steam cleaning the engine will remove accumulated oil and grease. A clean engine provides the following benefits:

- Easy detection of fluid leaks
- Maximum heat transfer characteristics
- Ease of maintenance

Note: Caution must be used in order to prevent electrical components from being damaged by excessive water when you clean the engine. Avoid electrical components such as the alternator, the starter, and the Electronic Control Module (ECM).

Engine Air Cleaner Element (Single Element) - Inspect/Clean/Replace

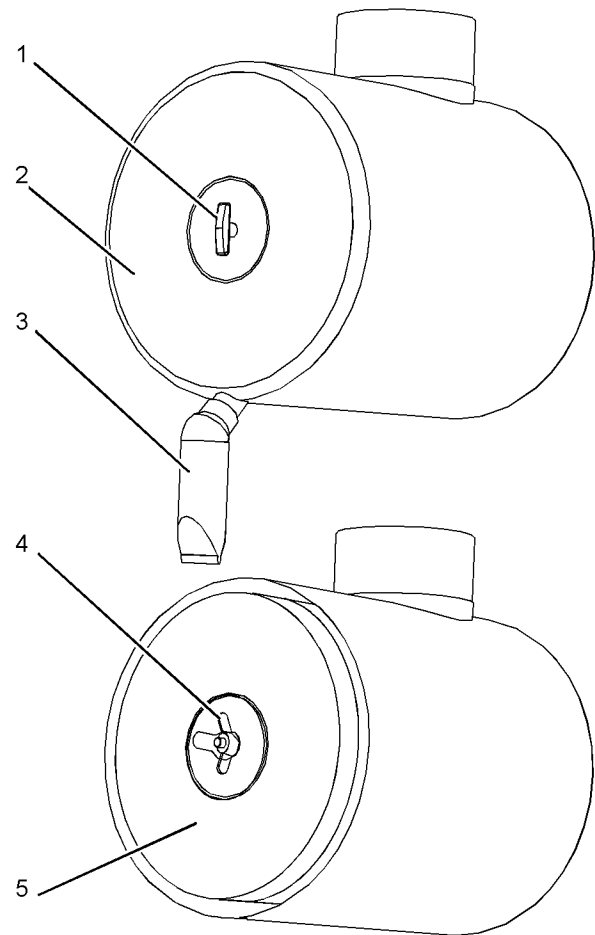

Illustration 45

g02795542

Typical example

1. Rotate fastener (1) counter clockwise and remove end cover (2). Remove inner fastener (4) and remove old element (5).
2. Insure that all components are clean and free from dirt. Do not allow dirt to enter the induction system. Check all induction hoses.
3. Install new element and install fastener (4). Tighten fastener securely.
4. Install end cover (2). Insure that valve (3) is vertically down and tighten fastener (1) securely.

i02568159

i07819538

Engine Air Cleaner Service Indicator - Inspect (If Equipped)

Some engines may be equipped with a different service indicator.

Some engines are equipped with a differential gauge for inlet air pressure. The differential gauge for inlet air pressure displays the difference in the pressure that is measured before the air cleaner element and the pressure that is measured after the air cleaner element. As the air cleaner element becomes dirty, the pressure differential rises. If your engine is equipped with a different type of service indicator, follow the OEM recommendations in order to service the air cleaner service indicator.

The service indicator may be mounted on the air cleaner housing or in a remote location.

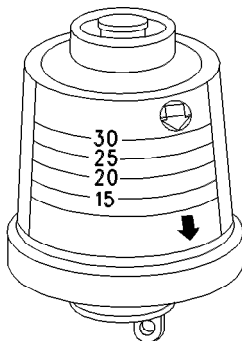

Illustration 46

g00103777

Typical service indicator

Observe the service indicator. The air cleaner element should be cleaned or the air cleaner element should be replaced when the following condition occurs:

- The red piston locks in the visible position.

i04654709

Engine Air Precleaner - Check/Clean

If equipped, the precleaner should be checked daily and cleaned as required.

Engine Mounts - Inspect

Note: The engine mounts may not have been supplied by Perkins. Refer to the Original Equipment Manufacturer (OEM) information for further details on the engine mounts and the correct bolt torque.

Inspect the engine mounts for deterioration and for correct bolt torque. Excessive engine vibration can be caused by the following conditions:

- Incorrect mounting of the engine
- Deterioration of the engine mounts
- Loose engine mounts

Any engine mount that shows deterioration should be replaced. Refer to the OEM information for the recommended torques.

When the engine mounts are supplied by Perkins the maintenance procedure will be supplied in the Disassembly and Assembly manual for your engine.

i04760772

Engine Oil Level - Check

WARNING

Hot oil and hot components can cause personal injury. Do not allow hot oil or hot components to contact the skin.

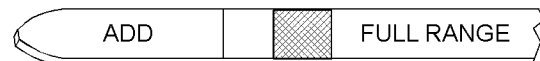

Illustration 47

g02854696

Typical example

NOTICE

Perform this maintenance with the engine stopped.

Maintenance Section
Engine Oil and Filter - Change

Note: Ensure that the engine is either level or that the engine is in the normal operating position in order to obtain a true level indication.

Note: After the engine has been switched OFF, wait for 10 minutes in order to allow the engine oil to drain to the oil pan before checking the oil level.

1. Maintain the oil level between the **FULL RANGE** marks on the engine oil dipstick. Refer to illustration 47. Do not fill the crankcase above the **FULL RANGE** marks.

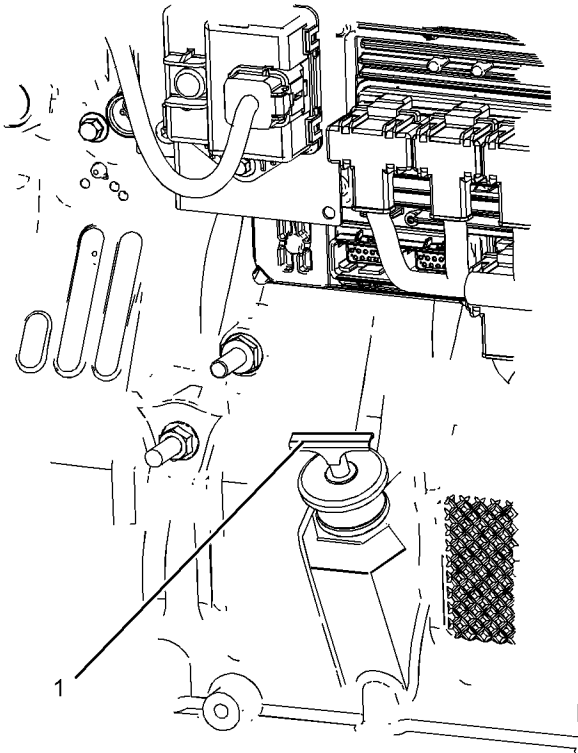

Illustration 48

g02854697

Typical example

NOTICE

Operating your engine when the oil level is above the **FULL RANGE** marks could cause your crankshaft to dip into the oil. The air bubbles created from the crankshaft dipping into the oil reduces the oils lubricating characteristics and could result in the loss of power.

2. Remove the oil filler cap (1), by rotating counterclock wise, and add oil, if necessary. Clean the oil filler cap. Install the oil filler cap. Tighten oil fill cap clockwise, ensure that the oil filler cap is secure.

i04272814

Engine Oil and Filter - Change (1606A Engine)

⚠ WARNING

Hot oil and hot components can cause personal injury. Do not allow hot oil or hot components to contact the skin.

NOTICE

Care must be taken to ensure that fluids are contained during performance of inspection, maintenance, testing, adjusting and repair of the product. Be prepared to collect the fluid with suitable containers before opening any compartment or disassembling any component containing fluids.

Dispose of all fluids according to local regulations and mandates.

NOTICE

Keep all parts clean from contaminants.

Contaminants may cause rapid wear and shortened component life.

NOTICE

The procedure to change the engine oil and oil filter for both types of engine are the same, but the service interval for both engine are different.

Do not drain the engine lubricating oil when the engine is cold. As the engine lubricating oil cools, suspended waste particles settle on the bottom of the oil pan. The waste particles are not removed with draining cold oil. Drain the oil pan with the engine stopped. Drain the oil pan with the oil warm. This draining method allows the waste particles that are suspended in the oil to be drained properly.

Failure to follow this recommended procedure will cause the waste particles to be recirculated through the engine lubrication system with the new oil.

Drain the Engine Lubricating Oil

Note: Ensure that the vessel that will be used is large enough to collect the waste oil.

After the engine has been run at the normal operating temperature, stop the engine.

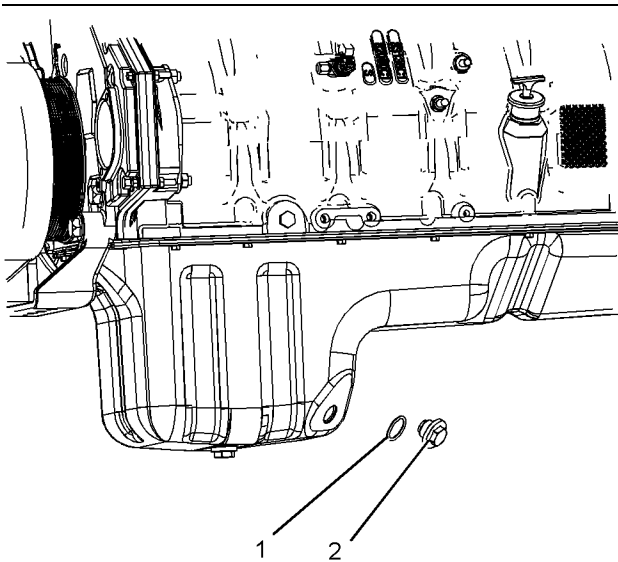

Illustration 49

g02725694

Typical example

1. Remove the drain plug (2) and allow the oil to drain.
2. After the oil has drained, the drain plug should be cleaned and installed. Install a new O ring seal (1) onto the drain plug.

3. Install the drain plug and tighten to 68 N·m (50 lb ft).

Replace the Oil Filter

Illustration 50

g02725761

Use a suitable container in order to catch the oil that will drain from the filter. Ensure that the filter assembly is clean and free from dirt.

1. Using a suitable tool remove the oil filter (2).

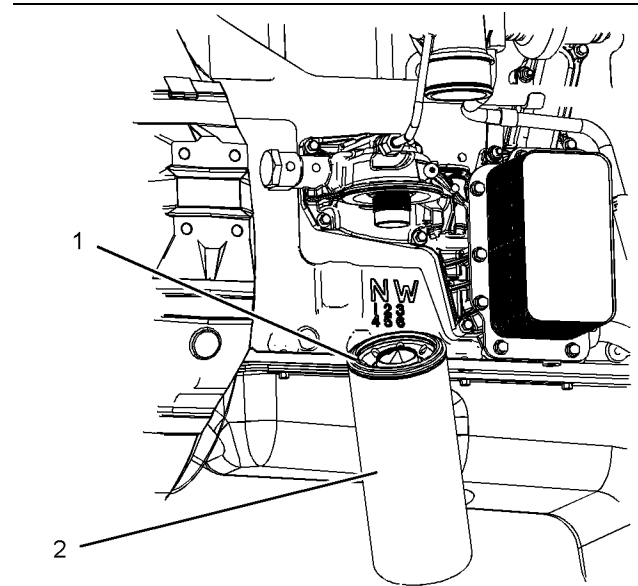
Note: Ensure that the sealing faces is clean.

2. Lubricate the O ring seal (1) on the new oil filter with clean engine oil. Spin on the new oil filter until the O ring seal contacts the sealing face, then turn the oil filter $\frac{3}{4}$ of a turn.

Fill the Oil Pan

1. Remove the oil filler cap. Refer to this Operation and Maintenance Manual, "Fluid Recommendations" for more information on suitable oils. Fill the oil pan with the correct amount of new engine lubricating oil. Refer to this Operation and Maintenance Manual, "Refill Capacities" for more information on refill capacities.
2. Start the engine and operate the engine without load for approximately 2 minutes, in order to allow the oil to fill the oil filter. Check that the oil pressure is correct and check for oil leaks. Stop the engine and allow the oil to drain back to the oil pan for 10 minutes.

Note: Ensure that the crankcase is not over full.

3. Check the engine oil level and add oil as necessary. Replace the filler cap and start the engine.

i04807924

Engine Oil and Filter - Change (1606D Engine)

NOTICE

Changing the engine oil and oil filter for both types of engine are the same, but the Maintenance interval for both engines are different.

The maintenance interval for the 1606D engine is 400 hours.

i04272831

Engine Valve Lash - Check

Table 14

Table 1 Valve Lash Schedule	
Schedule Type	Hours
Standby Power	Every 500
Prime Power	Initial 500
	Every 1000

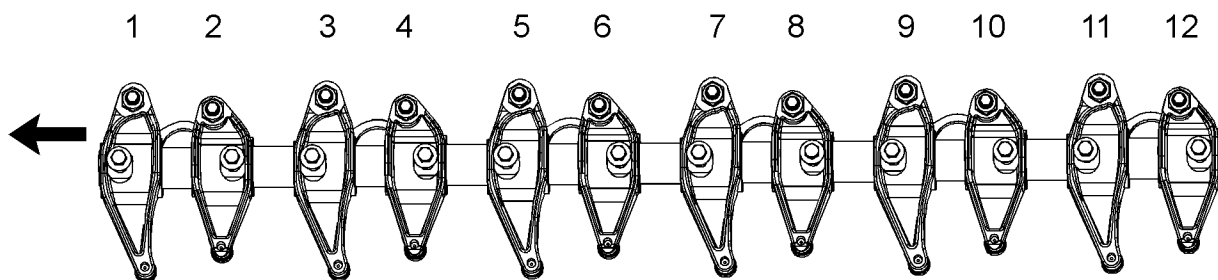

Illustration 51

Typical example

g02793297

Remove the valve mechanism cover. Refer to Disassembly and Assembly, "Valve Mechanism Cover-Remove and Install"

Rotate crankshaft in order to get number one piston at top dead center position with both valves on number six cylinder on overlap. Set the valve lash, use table 2 valve lash. The inlet valve lash and exhaust Valve lash is set cold to 0.48 mm (0.019 inch).

Table 15

Table 2 Valve Lash					
1 Inlet	2 Exhaust	3 Inlet	6 Exhaust	7 Inlet	10 Exhaust

Rotate crankshaft 360 degrees and set the valve lash, use table 3 valve lash in order to set the remaining valves.

Table 16

Table 3 Valve Lash					
4 Exhaust	5 Inlet	8 Exhaust	9 Inlet	11 Inlet	12 Exhaust

i04633518

Fan Clearance - Check

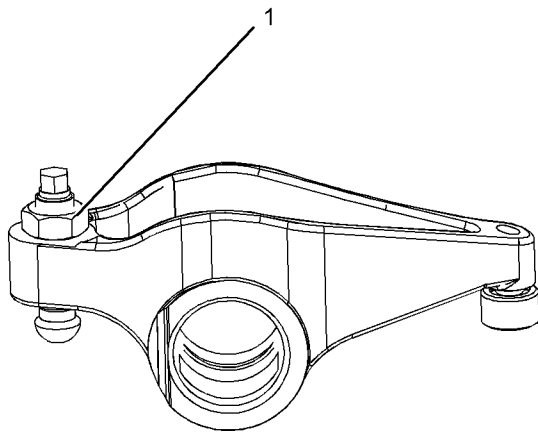

Illustration 52

g02793699

Typical example

The adjuster screw (1) must be torque to 27 N·m (20 lb ft). After tightening the adjuster screw the valve lash must be checked again.

Install the valve mechanism cover. For more information refer to System Operation Testing and Adjusting, "Engine Valve Lash -Inspect/Adjust".

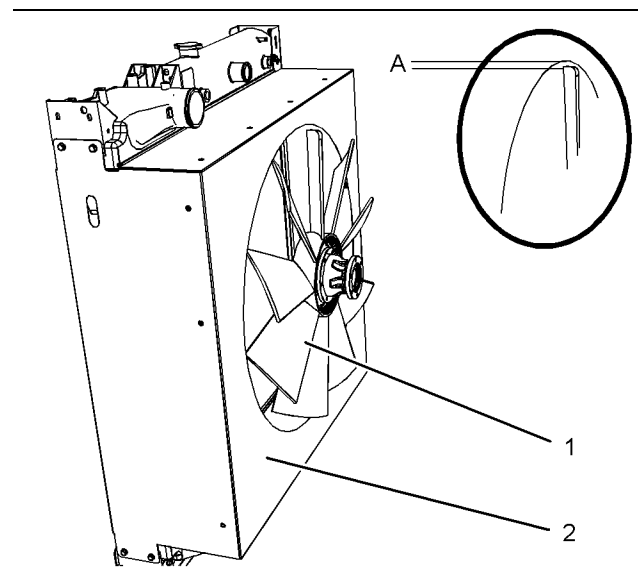

Illustration 53

g02778616

Typical example

Ensure that the engine is stopped. Ensure that the battery disconnect switch is in the OFF position.

Ensure that the cooling system is full. The clearance between the cover (2) and the fan (1) will require checking. The gap (A) between the cover and the edge of the fan blade must be checked in five equally spaced positions.

Adjustment of the cover will change the clearance gap between the cover and the edge of the fan blade. Ensure that the cover is centralized to the fan. The clearance (A) must be 21 ± 2 mm (0.82677 ± 0.07874 inch).

i04272833

Fuel System - Prime

Ensure that all adjustments and repairs are performed by authorized personnel that have had the correct training.

NOTICE

Do not crank the engine continuously for more than 30 seconds. Allow the starting motor to cool for two minutes before cranking the engine again.

If air enters the fuel system, the air must be purged from the fuel system before the engine can be started. Air can enter the fuel system when the following events occur:

- The fuel tank is empty or the fuel tank has been partially drained.
- The low-pressure fuel lines are disconnected.
- A leak exists in the low-pressure fuel system.
- The fuel filter has been replaced.

If you inspect the engine in operation, always use the proper inspection procedure in order to avoid a fluid penetration hazard. Refer to Operation and Maintenance Manual, "General hazard Information".

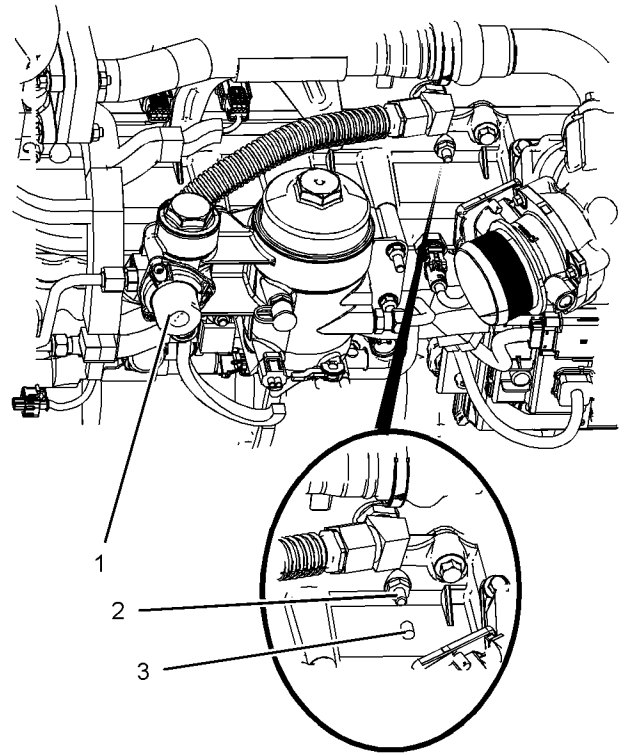

Illustration 54

g02837626

Typical example

Priming with leak off Tool

In order to purge air from the fuel system a tool is required. Use a PCL Air Technology Single Clip on Connector CO2H03 or similar. Install a suitable length of clear hose onto connector (A).

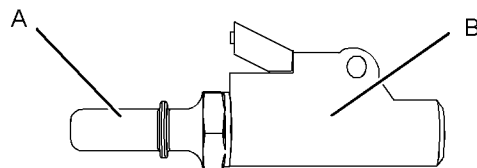

Illustration 55

g02948436

Typical example

1. Remove the dust cap (3) and install tool (B) onto schrader valve (2). Put the clear hose into a suitable container.

2. Depress the priming pump (1) in order to release the air from the system.
3. When fuel free from air comes from the schrader valve, stop depressing the priming pump. Remove the tool and install the dust cap.
4. Depress the priming pump for a short time in order to pressurize the system. Check the low-pressure system for leaks.
5. Priming the fuel filter from empty should take approximately 3 minutes. The time will be dependent on the location of the fuel tank.
6. Remove any container and clean any split fuel from the engine. The system is now primed and the engine ready to start. Operate the starting motor and start the engine.

i04557295

Fuel System Primary Filter - Clean/Inspect/Replace

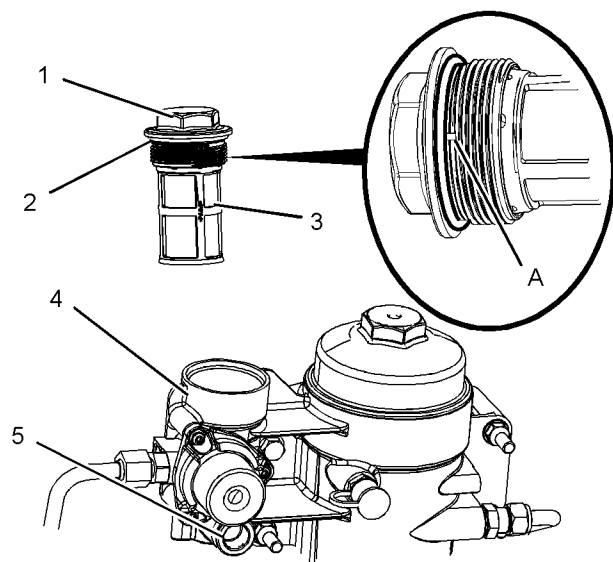

Illustration 56

g02791202

Typical example

Note: If the fuel system is gravity supplied, turn the inline tap to the OFF position before servicing the fuel system.

1. Ensure that the outer body of the filter assembly is clean and free from dirt. Remove cap (1) with element from filter body (4).

2. Remove O ring seal (2). Use cutout (A) in order to remove the O ring seal.
3. Ensure that the assembly is clean and free from dirt. Remove the element (6) from cap (2). Ensure that the element housing is clean and free from dirt. If dirt remains within the housing, the fuel line (5) must be removed, in order to allow cleaning of the housing.

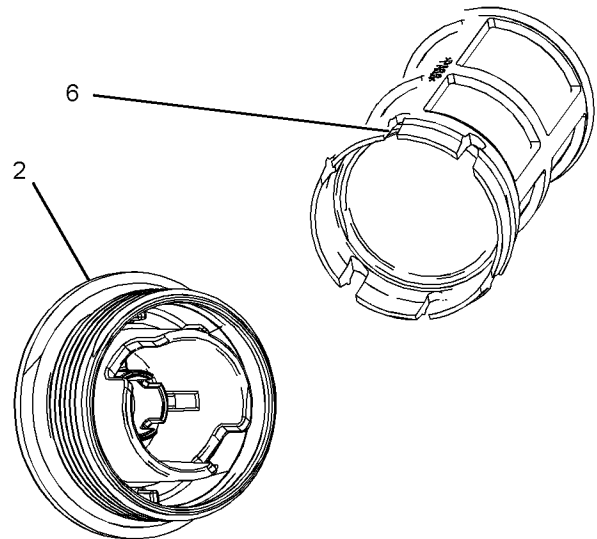

Illustration 57

g02791860

Typical example

4. Inspect the element, if the element is damaged, replace the element.
5. Align the element to the cap and push together. Install cap and element assembly into filter body and tighten to 18 N·m (13 lb ft). Turn the fuel inline supply tap to the ON position

i04654710

Fuel System Secondary Filter - Replace

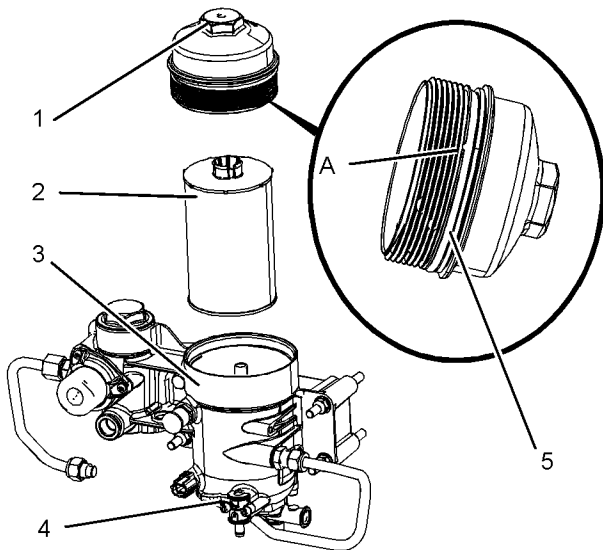

Illustration 58

g02792418

Typical example

1. Place a suitable container under the water separator in order to catch any fluid that might spill. Clean up any spilled fluid. Ensure that the outer body of the filter assembly is clean and free from dirt.
2. Install a suitable tube onto drain valve (4). Loosen the cap (1) in order to allow atmospheric pressure to act upon the fuel. Rotate the cap three and a half turns in order to allow the vent hole to be accessed. Open the drain valve (4) and allow the fluid to drain.
3. After the fluid has drained, Close the drain valve and remove the tube. Remove cap from filter body (3). Removing the cap will also remove the filter element (2). Remove filter element from the cap. Remove the O ring seal (5) from the cap. Use the cutout (A) in order to remove the O ring seal. Discard the O ring seal and the filter element.
4. Ensure that the cap, and the inner of the filter housing are clean and free from dirt.

5. Install new O ring seal to cap. Align new filter element to cap and push together. Lubricate the O ring seal and the threads on the cap with clean fuel and install the cap assembly into the filter housing.
6. Tighten the cap to 25 N·m (18 lb ft). Clean any split fluid and remove the container. Depose of all fluids in accordance with local regulations. Operate engine and check for leaks.

i04557309

Fuel System Water Separator - Check/Drain

WARNING

Fuel leaked or spilled onto hot surfaces or electrical components can cause a fire. To help prevent possible injury, turn the start switch off when changing fuel filters or water separator elements. Clean up fuel spills immediately.

NOTICE

Ensure that the engine is stopped before any servicing or repair is performed.

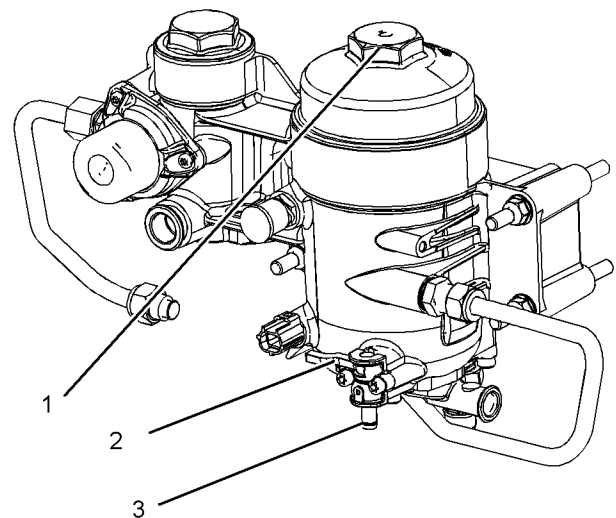

Illustration 59

g02724758

Typical example

1. Place a suitable container under the water separator in order to catch any fluid that might spill. Clean up any spilled fluid. Ensure that the outer body of the filter assembly is clean and free from dirt.
2. Install a suitable tube onto drain (3). Loosen the cap (1) in order to allow atmospheric pressure to act upon the fuel. Rotate the cap 3 and a half turns in order to allow the vent hole to be accessed. Open the drain valve (2) and allow the fluid to drain.
3. When fuel free of water comes from the drain valve, close the drain valve and tighten the vent cap to 30 N·m (22 lb ft)
4. Remove the drain tube and dispose of the drain fluid in accordance with local regulations.

i02568194

Fuel Tank Water and Sediment - Drain

NOTICE

Care must be taken to ensure that fluids are contained during performance of inspection, maintenance, testing, adjusting and repair of the product. Be prepared to collect the fluid with suitable containers before opening any compartment or disassembling any component containing fluids.

Dispose of all fluids according to local regulations and mandates.

Fuel Tank

Fuel quality is critical to the performance and to the service life of the engine. Water in the fuel can cause excessive wear to the fuel system.

Water can be introduced into the fuel tank when the fuel tank is being filled.

Condensation occurs during the heating and cooling of fuel. The condensation occurs as the fuel passes through the fuel system and the fuel returns to the fuel tank. This causes water to accumulate in fuel tanks. Draining the fuel tank regularly and obtaining fuel from reliable sources can help to eliminate water in the fuel.

Drain the Water and the Sediment

Fuel tanks should contain some provision for draining water and draining sediment from the bottom of the fuel tanks.

Open the drain valve on the bottom of the fuel tank in order to drain the water and the sediment. Close the drain valve.

Check the fuel daily. Allow five minutes after the fuel tank has been filled before draining water and sediment from the fuel tank.

Fill the fuel tank after operating the engine in order to drive out moist air. This will help prevent condensation. Do not fill the tank to the top. The fuel expands as the fuel gets warm. The tank may overflow.

Some fuel tanks use supply pipes that allow water and sediment to settle below the end of the fuel supply pipe. Some fuel tanks use supply lines that take fuel directly from the bottom of the tank. If the engine is equipped with this system, regular maintenance of the fuel system filter is important.

Fuel Storage Tanks

Drain the water and the sediment from the fuel storage tank at the following intervals:

- Service intervals
- Refill of the tank

This will help prevent water or sediment from being pumped from the storage tank into the engine fuel tank.

If a bulk storage tank has been refilled or moved recently, allow adequate time for the sediment to settle before filling the engine fuel tank. Internal baffles in the bulk storage tank will also help trap sediment. Filtering fuel that is pumped from the storage tank helps to ensure the quality of the fuel. When possible, water separators should be used.

i02568190

Hoses and Clamps - Inspect/ Replace

Inspect all hoses for leaks that are caused by the following conditions:

- Cracking
- Softness
- Loose clamps

Replace hoses that are cracked or soft. Tighten any loose clamps.

NOTICE

Do not bend or strike high pressure lines. Do not install bent or damaged lines, tubes or hoses. Repair any loose or damaged fuel and oil lines, tubes and hoses. Leaks can cause fires. Inspect all lines, tubes and hoses carefully. Tighten all connections to the recommended torque.

Check for the following conditions:

- End fittings that are damaged or leaking
- Outer covering that is chafed or cut
- Exposed wire that is used for reinforcement
- Outer covering that is ballooning locally
- Flexible part of the hose that is kinked or crushed
- Armoring that is embedded in the outer covering

A constant torque hose clamp can be used in place of any standard hose clamp. Ensure that the constant torque hose clamp is the same size as the standard clamp.

Due to extreme temperature changes, the hose will heat set. Heat setting causes hose clamps to loosen. This can result in leaks. A constant torque hose clamp will help to prevent loose hose clamps.

Each installation application can be different. The differences depend on the following factors:

- Type of hose
- Type of fitting material
- Anticipated expansion and contraction of the hose
- Anticipated expansion and contraction of the fittings

Replace the Hoses and the Clamps

WARNING

Pressurized System: Hot coolant can cause serious burns. To open the cooling system filler cap, stop the engine and wait until the cooling system components are cool. Loosen the cooling system pressure cap slowly in order to relieve the pressure.

1. Stop the engine. Allow the engine to cool.
2. Loosen the cooling system filler cap slowly in order to relieve any pressure. Remove the cooling system filler cap.

Note: Drain the coolant into a suitable, clean container. The coolant can be reused.

3. Drain the coolant from the cooling system to a level that is below the hose that is being replaced.
4. Remove the hose clamps.
5. Disconnect the old hose.
6. Replace the old hose with a new hose.
7. Install the hose clamps.
8. Refill the cooling system.
9. Clean the cooling system filler cap. Inspect the cooling system filler cap's gaskets. Replace the cooling system filler cap if the gaskets are damaged. Install the cooling system filler cap.
10. Start the engine. Inspect the cooling system for leaks.

i02857274

Radiator - Clean

The following text describes a typical cleaning procedure for the radiator. For information on equipment that is not supplied by Perkins, refer to the OEM.

Note: Adjust the frequency of cleaning according to the effects of the operating environment.

Inspect the radiator for these items: damaged fins, corrosion, dirt, grease, insects, leaves, oil and other debris. Clean the radiator, if necessary.

WARNING

Personal injury can result from air pressure.

Personal injury can result without following proper procedure. When using pressure air, wear a protective face shield and protective clothing.

Maximum air pressure at the nozzle must be less than 205 kPa (30 psi) for cleaning purposes.

Pressurized air is the preferred method for removing loose debris. Direct the air in the opposite direction of the fan's air flow. Hold the nozzle approximately 6 mm (0.25 inch) away from the fins. Slowly move the air nozzle in a direction that is parallel with the tubes. This will remove debris that is between the tubes.

Pressurized water may also be used for cleaning. The maximum water pressure for cleaning purposes must be less than 275 kPa (40 psi). Use pressurized water in order to soften mud. Clean the core from both sides.

Use a degreaser and steam for removal of oil and grease. Clean both sides of the core. Wash the core with detergent and hot water. Thoroughly rinse the core with clean water.

If the radiator is blocked internally, refer to the OEM for information regarding flushing the cooling system.

After cleaning the radiator, start the engine. This will help in the removal of debris and the drying of the core. Run the engine for two minutes and then stop the engine. Inspect the core for cleanliness. Repeat the cleaning, if necessary.

i02568202

Starting Motor - Inspect

Perkins recommends a scheduled inspection of the starting motor. If the starting motor fails, the engine may not start in an emergency situation.

Check the starting motor for proper operation. Check the electrical connections and clean the electrical connections. Refer to the Service Manual for more information on the checking procedure and for specifications or consult your Perkins distributors for assistance.

i04762414

Turbocharger - Inspect

Periodic inspection and cleaning are recommended for the turbocharger compressor housing (inlet side). Any fumes from the crankcase on the 1600D engine are filtered through the air inlet system. Therefore, by-products from oil and from combustion can collect in the turbocharger compressor housing. Over time, this buildup can contribute to loss of engine power, increased black smoke and overall loss of engine efficiency.

Note: An inspection is recommended for both engines, 1600A and 1600D.

If the turbocharger fails during engine operation, damage to the turbocharger compressor wheel and/or to the engine may occur. Damage to the turbocharger compressor wheel can cause additional damage to the pistons, the valves, and the cylinder head.

NOTICE

Turbocharger bearing failures can cause large quantities of oil to enter the air inlet and exhaust systems. Loss of engine lubricant can result in serious engine damage.

Minor leakage of a turbocharger housing under extended low idle operation should not cause problems as long as a turbocharger bearing failure has not occurred.

When a turbocharger bearing failure is accompanied by a significant engine performance loss (exhaust smoke or engine rpm up at no load), do not continue engine operation until the turbocharger is repaired or replaced.

An inspection of the turbocharger can minimize unscheduled downtime. An inspection of the turbocharger can also reduce the chance for potential damage to other engine parts.

Note: Turbocharger components require precision clearances. The turbocharger cartridge must be balanced due to high rpm. Severe Service Applications can accelerate component wear. Severe Service Applications require more frequent inspections of the cartridge.

Removal and Installation

For options regarding the removal, installation, repair, and replacement, consult your Perkins distributor. Refer to the Service Manual for this engine for the procedure and specifications.

Cleaning and Inspecting

1. Remove the exhaust outlet piping and remove the air inlet piping from the turbocharger. Visually inspect the piping for the presence of oil. Clean the interior of the pipes in order to prevent dirt from entering during reassembly.
2. Turn the compressor wheel and the turbine wheel by hand. The assembly should turn freely. Inspect the compressor wheel and the turbine wheel for contact with the turbocharger housing. There should not be any visible signs of contact between the turbine wheel or compressor wheel and the turbocharger housing. If there is any indication of contact between the rotating turbine wheel or the compressor wheel and the turbocharger housing, the turbocharger must be reconditioned.

3. Check the compressor wheel for cleanliness. If only the blade side of the wheel is dirty, dirt and/or moisture is passing through the air filtering system. If oil is found only on the back side of the wheel, there is a possibility of a failed turbocharger oil seal.

The presence of oil may be the result of extended engine operation at low idle. The presence of oil may also be the result of a restriction of the line for the inlet air (plugged air filters), which causes the turbocharger to slobber.

4. Use a dial indicator to check the end clearance on the shaft. If the measured end play is greater than the Service Manual specifications, the turbocharger should be repaired or replaced. An end play measurement that is less than the minimum Service Manual specifications could indicate carbon buildup on the turbine wheel. The turbocharger should be disassembled for cleaning and for inspection if the measured end play is less than the minimum Service Manual specifications.
5. Inspect the bore of the turbine housing for corrosion.
6. Clean the turbocharger housing with standard shop solvents and a soft bristle brush.
7. Fasten the air inlet piping and the exhaust outlet piping to the turbocharger housing.

i02568213

Walk-Around Inspection

Inspect the Engine for Leaks and for Loose Connections

A walk-around inspection should only take a few minutes. When the time is taken to perform these checks, costly repairs and accidents can be avoided.

For maximum engine service life, make a thorough inspection of the engine compartment before starting the engine. Look for items such as oil leaks or coolant leaks, loose bolts, worn belts, loose connections and trash buildup. Make repairs, as needed:

- The guards must be in the proper place. Repair damaged guards or replace missing guards.
- Wipe all caps and plugs before the engine is serviced in order to reduce the chance of system contamination.

NOTICE

For any type of leak (coolant, lube, or fuel) clean up the fluid. If leaking is observed, find the source and correct the leak. If leaking is suspected, check the fluid levels more often than recommended until the leak is found or fixed, or until the suspicion of a leak is proved to be unwarranted.

NOTICE

Accumulated grease and/or oil on an engine or deck is a fire hazard. Remove this debris with steam cleaning or high pressure water.

- Ensure that the cooling lines are properly clamped and that the cooling lines are tight. Check for leaks. Check the condition of all pipes.
- Inspect the water pumps for coolant leaks.

Note: The water pump seal is lubricated by coolant in the cooling system. It is normal for a small amount of leakage to occur as the engine cools down and the parts contract.

Excessive coolant leakage may indicate the need to replace the water pump seal. For the removal of water pumps and the installation of water pumps and/or seals, refer to the Service Manual for the engine or consult your Perkins distributor.

- Inspect the lubrication system for leaks at the front crankshaft seal, the rear crankshaft seal, the oil pan, the oil filters and the valve cover.
- Inspect the fuel system for leaks. Look for loose fuel line clamps or for loose fuel line tie-wraps.
- Inspect the piping for the air inlet system and the elbows for cracks and for loose clamps. Ensure that hoses and tubes are not contacting other hoses, tubes, wiring harnesses, etc.
- Inspect the alternator belt and the accessory drive belts for cracks, breaks or other damage.

Belts for multiple groove pulleys must be replaced as matched sets. If only one belt is replaced, the belt will carry more load than the belts that are not replaced. The older belts are stretched. The additional load on the new belt could cause the belt to break.

- Drain the water and the sediment from fuel tanks on a daily basis in order to ensure that only clean fuel enters the fuel system.
- Inspect the wiring and the wiring harnesses for loose connections and for worn wires or frayed wires.
- Inspect the ground strap for a good connection and for good condition.

- Inspect the ECM to the cylinder head ground strap for a good connection and for good condition.
- Disconnect any battery chargers that are not protected against the current drain of the starting motor. Check the condition and the electrolyte level of the batteries, unless the engine is equipped with a maintenance free battery.
- Check the condition of the gauges. Replace any gauges that are cracked. Replace any gauge that can not be calibrated.

i02568235

Water Pump - Inspect

A failed water pump might cause severe engine overheating problems that could result in the following conditions:

- Cracks in the cylinder head
- A piston seizure
- Other potential damage to the engine

Visually inspect the water pump for leaks. If any leaking is observed, replace the water pump seal or the water pump assembly. Refer to the Service Manual for the disassembly and assembly procedure.

Note: Refer to the Service Manual or consult your Perkins distributor if any repair is needed or any replacement is needed.

Warranty Section

Warranty Information

i06590874

Emissions Warranty Information

This engine may be certified to comply with exhaust emission and gaseous emission standards that are prescribed by the law at the time of manufacture. This engine may be covered by an Emissions Warranty. Consult your authorized Perkins dealer or distributor to determine if your engine is emissions certified and if your engine is subject to an Emissions Warranty.

Index

A

After Starting Engine	44
After Stopping Engine	49
Aftercooler Core - Inspect/Clean/Test	67
Alarms and Shutoffs	31
Engine Alarms	31
Engine Shutoffs	31
Alternator - Inspect	67
Alternator and Fan Belts - Replace	68

B

Battery - Replace	68
Battery Electrolyte Level - Check	69
Battery or Battery Cable - Disconnect	69
Before Starting Engine	16, 43
Belt - Inspect	70
Belt Tensioner - Check	70
Burn Prevention	12
Batteries	13
Coolant	12
Induction System	12
Oils	13

C

Cold Weather Operation	46
Hints for Cold Weather Operation	46
Recommendations for the Coolant	46
Viscosity of the Engine Lubrication Oil	46
Cold Weather Starting	43
Coolant (Commercial Heavy-Duty) -	
Change	70
Drain	71
Fill	72
Flush	71
Coolant (ELC) - Change	72
Drain	73
Fill	73
Flush	73
Coolant Level - Check	74
Cooling System Supplemental Coolant	
Additive (SCA) - Test/Add	74
Add the SCA, If Necessary	75
Test for SCA Concentration	74
Crankshaft Vibration Damper - Inspect	75
Crushing Prevention and Cutting Prevention ..	15

D

Driven Equipment - Check	76
--------------------------------	----

E

Electrical System	18
Grounding Practices	18
Emergency Stopping	49
Emissions Certification Film	27
Emissions Warranty Information	90
Engine - Clean	76
Engine Air Cleaner Element (Single	
Element) - Inspect/Clean/Replace	76
Engine Air Cleaner Service Indicator -	
Inspect (If Equipped)	77
Engine Air Precleaner - Check/Clean	77
Engine Diagnostics	42
Engine Electronics	18
Engine Mounts - Inspect	77
Engine Oil and Filter - Change (1606A	
Engine)	78
Drain the Engine Lubricating Oil	78
Fill the Oil Pan	79
Replace the Oil Filter	79
Engine Oil and Filter - Change (1606D	
Engine)	80
Engine Oil Level - Check	77
Engine Operation	45
Engine Operation with Active Diagnostic	
Codes	42
Engine Operation with Intermittent	
Diagnostic Codes	42
Engine Starting	17, 43
Engine Stopping	17, 49
Engine Valve Lash - Check	80

F

Fan Clearance - Check	81
Fault Logging	42
Features and Controls	31
Fire Prevention and Explosion Prevention	13
Fire Extinguisher	14
Lines, Tubes, and Hoses	14
Fluid Recommendations	50, 54–55
Diesel Fuel Characteristics	58
Diesel Fuel Requirements	56
ELC Cooling System Maintenance	51
Engine Oils	54

General Coolant Information	50	M	
General Information	56	Maintenance Interval Schedule	66
General Lubricant Information	54	Commissioning	66
Foreword	4	Daily	66
California Proposition 65 Warning	4	Every 2000 Service Hours	66
Literature Information	4	Every 250 Service Hours or 1 Year	66
Maintenance	4	Every 3000 Service Hours	66
Maintenance Intervals	5	Every 3000 Service Hours or 2 Years	66
Operation	4	Every 400 Service Hours	66
Overhaul	5	Every 500 Service Hours	66
Safety	4	Every 500 Service Hours or 1 Year	66
Fuel and the Effect from Cold Weather	47	Every 6000 Service Hours or 3 Years	66
Fuel Conservation Practices	45	When Required	66
Fuel Related Components in Cold Weather ...	47	Maintenance Recommendations	63
Fuel Filter	48	Maintenance Section	50
Fuel Tanks	47	Model View Illustrations	20
Fuel System - Prime	82	1600A Engine	23
Priming with leak off Tool	82	1600D Engine	20
Fuel System Primary Filter - Clean/Inspect/ Replace	83	Coolant System for 1600D Engine	22
Fuel System Secondary Filter - Replace	84	Monitoring System	32
Fuel System Water Separator - Check/Drain..	84	Programmable Options and Systems Operation	32
Fuel Tank Water and Sediment - Drain	85	Mounting and Dismounting	15
Drain the Water and the Sediment	85	O	
Fuel Storage Tanks	85	Operation Section	30
Fuel Tank	85	P	
G		Plate Locations and Film Locations	25
Gauges and Indicators	31	Engine Identification	25
General Hazard Information	8	Serial Number Plate (1)	26
Asbestos Information	11	Product Description	23
Containing Fluid Spillage	11	Aftermarket Products and Perkins Engines	24
Dispose of Waste Properly	12	Engine Specifications	23
Fluid Penetration	10	Product Identification Information	25
Hexavalent Chromium	9	Product Information Section	20
Pressurized Air and Water	10	Product Lifting	30
General Information	20	Product Storage	30
H		Level "A "	30
High Pressure Oil Lines	15	Level "B "	30
Hoses and Clamps - Inspect/Replace	85	Level "C "	30
Replace the Hoses and the Clamps	86	R	
I		Radiator - Clean	86
Important Safety Information	2	Reference Information	29
L		Record for Reference	29
Lifting and Storage	30	Refill Capacities	50
		Cooling System	50

Lubrication System 50

S

Safety Messages.....	6
(1) Universal Warning	6
(2) Hand (High Pressure)	7
Safety Section	6
Self-Diagnostics	42
Sensors and Electrical Components.....	32
Wiring Harness	41
Severe Service Application	64
Environmental Factors.....	65
Incorrect Maintenance Procedures	65
Incorrect Operating Procedures	65
Starting Motor - Inspect.....	87
Starting the Engine.....	44
Starting the Engine	44
Starting with Jump Start Cables.....	44
Stopping the Engine	49
System Pressure Release.....	63
Coolant System	63
Engine Oil	63
Fuel System.....	63

T

Table of Contents	3
Turbocharger - Inspect	87
Cleaning and Inspecting	87
Removal and Installation	87

W

Walk-Around Inspection	88
Inspect the Engine for Leaks and for Loose Connections	88
Warranty Information.....	90
Warranty Section.....	90
Water Pump - Inspect.....	89
Welding on Engines with Electronic Controls	63

Product and Dealer Information

Note: For product identification plate locations, see the section "Product Identification Information" in the Operation and Maintenance Manual.

Delivery Date: _____

Product Information

Model: _____

Product Identification Number: _____

Engine Serial Number: _____

Transmission Serial Number: _____

Generator Serial Number: _____

Attachment Serial Numbers: _____

Attachment Information: _____

Customer Equipment Number: _____

Dealer Equipment Number: _____

Dealer Information

Name: _____ Branch: _____

Address: _____

Dealer Contact

Phone Number

Hours

Sales: _____

Parts: _____

Service: _____

SEBU8455
©2021 Perkins Engines Company Limited
All Rights Reserved