



Cat[®] D4K2

TRACK-TYPE TRACTOR

FEATURES:

- **Slope Indicate** – New optional grade control feature provides you slope of blade in cross slope direction and mainfall (fore/aft) direction without having to estimate.
- **Slope Assist** – New optional grade control feature which helps you more easily achieve the desired blade mainfall and cross slope automatically.
- **Stable Blade** – New optional blade control feature helps you obtain a finish grade with less operator effort.
- **Traction Control** – New optional traction control feature reduces track slip and undercarriage wear for lower operating costs.
- **Eco Mode** – New engine throttle settings reduce fuel consumption up to 25% to save you more money.
- **Heated and Ventilated Seat** – Experience a new level of comfort in all climates with the new optional heated and ventilated air suspension seat.
- **Power Pitch Blade** – This option lets the operator easily adjust the blade pitch to optimize productivity.
- **Engine** – Cat[®] C4.4 ACERT™ diesel engine equivalent to U.S. EPA Tier 3 emissions levels.
- **Heated, Seat-Mounted Controls** – Heated joysticks (optional) offer even greater comfort in cold climates.
- **AccuGrade™** – Optional grade control system enables operators to cut and fill to grade with increased accuracy, minimizing the need for traditional stakes and grade checkers. Large AccuGrade monitor is built into the machine's dash for easy viewing during operation.
- **Undercarriage** – Choice of undercarriage to give you the lowest costs per hour. Select either the standard sealed and lubricated track (SALT) undercarriage or the innovative SystemOne™ undercarriage.

Specifications

Engine

Engine Model	Cat C4.4 ACERT	
Rated Net Power @ 2,200 rpm		
SAE J1349	62.6 kW	84 hp
ISO 9249/EEC 80/1269	62.6 kW	84 hp
Bore	105 mm	4.13 in
Stroke	127 mm	5 in
Displacement	4.4 L	269 in ³

- Engine equivalent to Tier 3 emissions levels.

Weights

Operating Weight – XL	8072 kg	17,796 lb
Operating Weight – LGP	8380 kg	18,475 lb

- Specifications shown are for machine equipped with dozer blade, canopy ROPS, back-up alarm, operator, coolant, lubricants and full fuel tank.

Cab

Sound Levels:	
ISO 6396:2008	79 dB(A)
SAE J1166 FEB2008	79 dB(A)
ROPS	ISO 3471:2008
FOPS	ISO 3449:2005 Level II

Transmission

Drive Pumps	1	
Track Motors	2	
Relief Valve Settings	48 500 kPa	7,033 psi
Maximum Travel Speed – Forward	9 km/h	5.6 mph
Maximum Travel Speed – Reverse	10 km/h	6.2 mph

Undercarriage

Number of Rollers (each side)	7	
Number of Shoes (each side) – Sealed and Lubricated Track (SALT) Undercarriage	43	
Number of Shoes (each side) – SystemOne Undercarriage	38	
Shoe Width – XL	460 mm	18 in
Shoe Width – LGP	635 mm	25 in
Length of Track on Ground – XL	2248 mm	89 in
Length of Track on Ground – LGP	2248 mm	89 in
Track Gauge – XL	1550 mm	61 in
Track Gauge – LGP	1725 mm	68 in
Ground Contact Area – XL	20 682 cm ²	3,206 in ²
Ground Contact Area – LGP	28 550 cm ²	4,425 in ²
Ground Pressure – XL	38.6 kPa	5.6 psi
Ground Pressure – LGP	29.2 kPa	4.2 psi



D4K2 Track-Type Tractor

Service Refill Capacities

Fuel Tank	195 L	51.5 gal
Crankcase and Filter	11 L	2.91 gal
Final Drives, XL (each side)	10 L	2.6 gal
Final Drives, LGP (each side)	10 L	2.6 gal
Cooling System	22.4 L	5.92 gal
Transmission/Hydraulic Tank	59.5 L	15.7 gal

Hydraulic Controls

Pump Output	68 L/min	17.7 gal/min
Relief Valve Settings	20 600 kPa	2,988 psi

Ripper

Type	Parallelogram	
Number of Shanks	3	
Maximum Digging Depth	337.5 mm	13.3 in
Maximum Reach at Ground Line	596 mm	23.5 in
Maximum Ground Clearance Under Tip	448 mm	17.6 in
Overall Width	1710 mm	67.3 in
Height	165 mm	6.5 in
Weight	554 kg	1,222 lb

Winch

Weight	610 kg	1,345 lb
Winch Drive	Hydrostatic	
Control	Hydraulic	
Speed	Variable	
Winch Length	705 mm	27.76 in
Overall Width	741 mm	29.2 in
Drum Diameter	254 mm	10 in
Drum Width	274 mm	10.8 in
Throat Clearance	171.5 mm	6.75 in
Rope Diameter – recommended	16 mm	0.63 in
Rope Diameter – optional	19 mm	0.75 in
Drum Capacity – recommended cable	113 m	371 ft
Drum Capacity – optional cable	78 m	256 ft
Maximum Line Pull – bare drum	18 144 kg	40,000 lb
Maximum Line Pull – full drum	11 340 kg	25,000 lb
Maximum Line Speed – bare drum	40 m/min	131 ft/min
Maximum Line Speed – full drum	63 m/min	207 ft/min

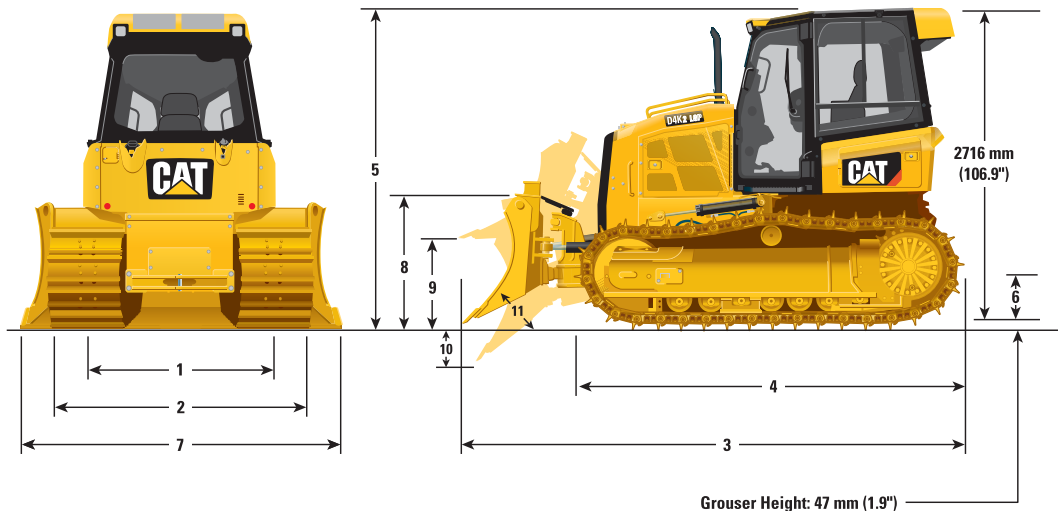

Dimensions

	XL		LGP			
1 Track Gauge	1550 mm	61 in	1725 mm	67.9 in		
2 Width of Tractor (standard shoes, no blade)	2010 mm	79.1 in	2360 mm	92.9 in		
3 Overall Length (with blade)	4274 mm	168.3 in	4274 mm	168.3 in		
4 Length of Basic Tractor (without blade)	3275 mm	128.9 in	3275 mm	128.9 in		
5 Tractor Height	2763 mm	108.8 in	2763 mm	108.8 in		
6 Ground Clearance	332 mm	13 in	332 mm	13 in		
BLADE						
		XL	Intermediate		LGP	
7 Blade Width	2782 mm	109.5 in	2921 mm	115 in	3149 mm	124 in
8 Blade Height	1010 mm	39.8 in	860 mm	33.9 in	910 mm	35.8 in
9 Blade Lift Height	743 mm	29.3 in	743 mm	29.3 in	708 mm	27.9 in
10 Digging Depth	573 mm	22.5 in	590 mm	23.2 in	590 mm	23.2 in
11 Blade Cutting Edge Angle, Adjustable		52° to 58°	52° to 58°		52° to 58°	
Maximum Tilt	387 mm	15.2 in	448 mm	17.6 in	438 mm	17.2 in
Maximum Angle (either side)		25°		25°		25°
Blade Width at Maximum Angle	2542 mm	100.1 in	2669 mm	105.1 in	2874 mm	113.1 in
Blade Capacity (SAE)	1.98 m ³	2.59 yd ³	1.50 m ³	1.96 yd ³	1.85 m ³	2.42 yd ³

STANDARD EQUIPMENT

ELECTRICAL

- Alternator, 12 volt, 120 Amp, heavy duty brushless
- Alarm, backup
- Batteries, heavy duty, maintenance free, 1,500 CCA
- Diagnostic connector
- Horn, electric
- Lights, halogen, 2 front and 2 rear
- Starter, electric, 12 volt

OPERATOR STATION

- ROPS/FOPS canopy
- Seat, air suspended, cloth or vinyl
- Seatbelt, retractable 76 mm (3 in)
- Foot pads, dash
- Electronic Monitoring System with:
 - Gauges for engine coolant temperature, hydraulic oil temperature and fuel level
 - Travel speed limiter, electronic
 - Engine RPM and gear display
 - Hour meter, electric
 - Engine air cleaner service indicator, electronic
 - Water-in-fuel indicator, electronic
- Throttle switch, rotary
- Eco mode
- Controls, seat mounted, fore/aft adjustment
- Armrests, adjustable
- Mirror, rearview, inside
- Single pedal combining deceleration and braking functions
- Independent forward/reverse speed settings
- Power port, 12 volt
- Coat hook
- Storage compartment
- Cup holder
- Floor mat, rubber, heavy duty

HYDRAULICS

- Hydraulics, 3 valve
- Load sensing hydraulics
- Single lever, three function control
- Hydraulic pump and oil

POWER TRAIN

- Cat C4.4 ACERT diesel engine, turbocharged, equivalent to Tier 3 emissions levels
- Aftercooler, Air-to-Air (ATAAC)
- Aluminum bar plate cooling system (radiator, power train)
- Air cleaner with precleaner, automatic dust ejection and under-hood intake
- Dual path, closed-loop hydrostatic transmission
- Electric fuel priming pump
- Fuel/water separator

UNDERCARRIAGE

- SALT Undercarriage
- 7 roller track frame
- Track rollers, lifetime lubricated
- Carrier rollers
- Track adjusters, hydraulic
- Guards, front/rear guiding
- Master link

OTHER STANDARD EQUIPMENT

- Cat Product Link™ PL631 Satellite/PL641 Cellular
- C-Frame, VPAT, hydraulic cylinders and lines
- Lockable engine enclosures
- Front pull device
- Rigid drawbar
- Ecology drains (engine, power train and implement oil and engine coolant)
- Scheduled oil sampling ports (engine, power train implement oil)
- Vandalism protection
- Heavy duty crankcase guard

ANTIFREEZE

- Extended life coolant, -37° C (-35° F)

D4K2 Track-Type Tractor

OPTIONAL EQUIPMENT

ELECTRICAL

- Integrated four front halogen lights, two rear halogen lights

POWER TRAIN

- Automatic Traction Control
- Installation, winch

UNDERCARRIAGE

- Track Pairs, XL:
 - Track, 460 mm (18 in) MS SystemOne
- Track Pairs, LGP:
 - Track, 635 mm (25 in) MS SystemOne

OPERATOR STATION

- Cab with air conditioning
- Cab, polycarbonate windows and air conditioning
- Seat, air suspension, choice of:
 - Vinyl, heated seat with heated controls
 - Cloth, heated seat with heated controls
 - Cloth, heated and ventilated seat with heated controls
- Radio, AM/FM, Bluetooth
- Sound suppression

HYDRAULICS

- Hydraulics, 4 valve for use with ripper
- Hydraulics, 4 valve for use with winch

GUARDS

- Guard, rear, heavy duty
- Grill, radiator, heavy duty
- Guard, track guiding, center
- Guard, track roller, full length
- Screen, rear, cab
- Screen, side, cab
- Screen, rear, canopy
- Screen, front and doors, canopy
- Sweeps, front
- Sweeps, rear

BLADES

- VPAT XL blade
- VPAT LGP blade
- VPAT Intermediate blade

REAR ATTACHMENTS

- Drawbar, towing
- Mounting, winch
- Ripper, parallelogram, includes three shanks and teeth

REAR ATTACHMENT CONTROL

- Control, ripper
- Control, winch
- Control, ripper and winch

MACHINE CONTROL AND GUIDANCE

- Stable Blade
- Slope Indicate
- Installation, AccuGrade ready, includes Cat Grade Control Slope Assist
- Power Pitch blade control

STARTING AIDS

- Heater, engine, coolant, 120 volt
- Starting aid, ether

OTHER ATTACHMENTS

- Machine Security System

ANTIFREEZE

- Extended life coolant, -50° C (-58° F)

FIELD INSTALLED ATTACHMENT

- Winch, hydrostatic

For more complete information on Cat products, dealer services, and industry solutions, visit us on the web at www.cat.com

© 2017 Caterpillar
All rights reserved

Materials and specifications are subject to change without notice. Featured machines in photos may include additional equipment. See your Cat dealer for available options.

CAT, CATERPILLAR, SAFETY.CAT.COM, their respective logos, "Caterpillar Yellow" and the "Power Edge" trade dress, as well as corporate and product identity used herein, are trademarks of Caterpillar and may not be used without permission.

AEHQ7502-02 (11-2017)
Replaces AEHQ7502-01

