



Cat[®] CS34

Smooth Drum Vibratory Soil Compactor

The Cat[®] CS34 features a smooth drum and is ideally suited for granular soil applications.

Comfortable and Ergonomic Operator Station

- Features adjustable seat with integrated multifunction LCD display and control console
- Outstanding visibility to the front and rear of machine
- Low sound levels and vibration for greater operator comfort and productivity

Rear Vision Camera

- The rear vision camera enhances visibility for more complete operator control and safety

Exceptional Propel System

- Built around the exclusive Cat[®] dual pump propel system, two pumps provide separate dedicated flow to drum drive motor and rear axle motor for exceptional gradeability and traction in forward and reverse

Virtually Maintenance Free

- Extended maintenance intervals for vibratory system and hydraulic system, providing more uptime and lower maintenance costs

Powerful Cat[®] C3.4B Engine

- Meets US EPA Tier 4 Final and EU Stage IV emissions standards

Compact, Highly Maneuverable, and Transportable



Cat® CS34 Smooth Drum Vibratory Soil Compactor

Standard and Optional Equipment

Standard and optional equipment may vary. Consult your Cat dealer for details.

	Standard	Optional		Standard	Optional
OPERATOR ENVIRONMENT			POWER TRAIN		
ROPS/FOPS Platform	✓		Cat® C3.4B Engine	✓	
Vinyl Adjustable Seat with Integrated Console and LCD Display with Lockable Vandalism Guard	✓		Air Cleaner, Dual Element	✓	
Rear Vision Camera System with Color Touchscreen Display	✓		Two-Speed Throttle Switch, Eco-mode	✓	
Seat Belt	✓		Dual Propel Pumps; One for Drum Drive, One for Rear Axle	✓	
12-volt Power Outlet	✓		Fuel Filter, Water Separator, Priming Pump, Water Indicator	✓	
Horn, Backup Alarm	✓		Tilting Radiator/Hydraulic Oil Cooler	✓	
VIBRATORY SYSTEM			Dual Braking System	✓	
Smooth Drum	✓		Two-speed Hydrostatic Transmission	✓	
Single Amplitude, Single Frequency	✓		Transmission Guard		✓
Front Adjustable Steel Scraper	✓		ELECTRICAL		
			12-volt Electrical System	✓	
			120 ampere Alternator	✓	
			750 Cold-cranking Amps Battery Capacity	✓	
			OTHER		
			Sight Gauges for Hydraulic Oil Level and Radiator Coolant Level	✓	
			S•O•S SM Sampling Valves: Engine Oil, Hydraulic Oil, and Coolant	✓	
			Amber Rotating Light Package		✓
			Lockable Engine Enclosure, Hydraulic and Fuel Tanks	✓	

Cat® CS34 Smooth Drum Vibratory Soil Compactor

Technical Specifications

Engine - Powertrain

Engine Model	Cat® C3.4B	
Emissions	U.S. EPA Tier 4 Final	
Engine Power ISO 14396:2002	55.0 kW	74.0 hp
Gross Power SAE J1995:2014		
Net Power ISO 9249:2007*		
Net Power SAE J1349:2011*		
Displacement	3.4 L	207 in ³
Stroke	110 mm	3.9 in
Bore	99 mm	3.9 in
Max. Travel Speed (Forward or Reverse)	8.9 km/h	5.5 mph

Weights**

Operating Weight w/ ROPS/FOPS Canopy	4445 kg	9800 lb
Weight at Drum w/ ROPS/FOPS Canopy	2040 kg	4497 lb

Vibratory System Specifications

Frequency	35 Hz	2100 vpm
Nominal Amplitude	1.3 mm	0.05 in
Centrifugal Force	66.8 kN	15,000 lb
Static Linear Load	16 kg/cm	90 lbs/in

Service Refill Capacities

Fuel Tank, total capacity	113 L	30.0 gal
Cooling System	20.8 L	5.5 gal
Engine Oil w/ Filter	9.0 L	2.4 gal
Eccentric Weight Housing	53 L	14 gal
Axle and Final Drives	8.0 L	2.1 gal
Hydraulic Tank (service refill)	60 L	15.9 gal

* Net power advertised is the power available at the engine flywheel when equipped with a fan at maximum speed, air cleaner, clean emissions module, and alternator.

** Standard operating weight considers full fluids and 80 kg operator.

Cat® CS34 Smooth Drum Vibratory Soil Compactor

Technical Specifications

Dimensions

1	Overall Length	4.2 m	13.7 ft
2	Overall Width	1.4 m	4.5 ft
3	Drum Width	1270 mm	50.0 in
4	Drum Shell Thickness	20 mm	0.8 in
5	Drum Diameter	1016 mm	40.0 in
6	Overall Height	2.5 m	8.2 ft
7	Wheelbase	2.2 m	7.3 ft
8	Ground Clearance	348 mm	13.7 in
9	Curb Clearance	344 mm	13.5 in
	Inside Turning Radius	2.6 m	8.6 ft
	Hitch Articulation Angle	38°	
	Hitch Oscillation Angle	15°	

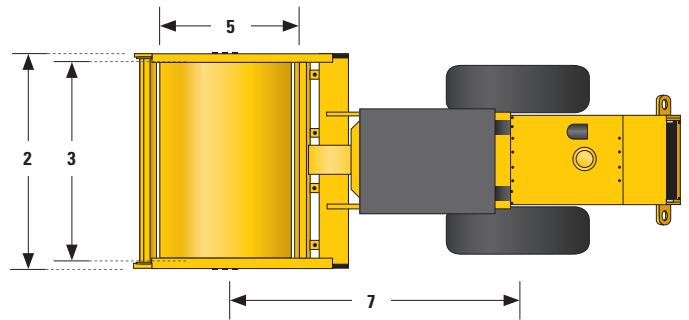
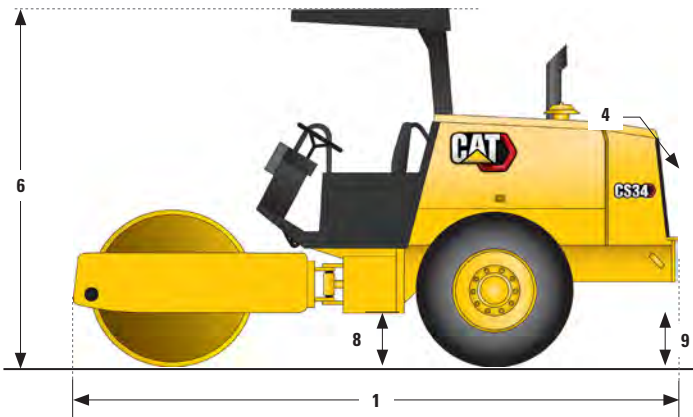

Environmental Declaration

The following information applies to the machine at the time of final manufacture as configured for sale in the regions covered in this document. The content of this declaration is valid as of the date issued; however, content related to machine features and specifications are subject to change without notice. For additional information, please see the machine's Operation and Maintenance Manual.

For more information on sustainability in action and our progress, please visit www.caterpillar.com/en/company/sustainability.html.

ENGINE

- The Cat C3.4B engine is available in configurations that meet U.S. EPA Tier 4 Final emission standards.
- Cat diesel engines are required to use ULSD (ultra-low sulfur diesel fuel with 15 ppm of sulfur or less) or ULSD blended with the following lower-carbon intensity fuels up to:
 - ✓ 20% biodiesel FAME (fatty acid methyl ester)*
 - ✓ 100% renewable diesel, HVO (hydrotreated vegetable oil) and GTL (gas-to-liquid) fuels

Refer to guidelines for successful application. Please consult your Cat dealer or "Caterpillar Machine Fluids Recommendations" (SEBU6250) for details.

**Engines with no aftertreatment devices can use higher blends, up to 100% biodiesel.*

PAINT

- Based on best available knowledge, the maximum allowable concentration, measured in parts per million (PPM), of the following heavy metals in paint are:
 - Barium < 0.01%
 - Cadmium < 0.01%
 - Chromium < 0.01%
 - Lead < 0.01%

SOUND PERFORMANCE

With cooling fan speed at maximum value:

Exterior Sound Pressure Level (SAE J88:2013) – 106 dB(A)

Operator Sound Pressure Level (ISO 6396:2008) – 94.4 dB(A)

- Hearing protection may be needed when operating with an open operator station for extended periods or in a noisy environment.

OILS AND FLUIDS

- Caterpillar factory fills with ethylene glycol coolants. Cat Diesel Engine Antifreeze/Coolant (DEAC) and Cat Extended Life Coolant (ELC) can be recycled. Consult your Cat dealer for more information.
- Cat BIO HYDO™ Advanced is an EU Ecolabel approved biodegradable hydraulic oil.
- Additional fluids are likely to be present, please consult the Operations and Maintenance Manual or the Application and Installation guide for complete fluid recommendations and maintenance intervals.

Cat® CS34 Smooth Drum Vibratory Soil Compactor

Cat® CS34 Smooth Drum Vibratory Soil Compactor

For more information on Cat products, dealer services, and industry solutions visit us on the web at www.cat.com.

© 2022 Caterpillar
All rights reserved.

Materials and specifications are subject to change without notice. Featured machines in photos may include additional equipment. See your Cat dealer for available options.

CAT, CATERPILLAR, LET'S DO THE WORK, their respective logos, "Caterpillar Corporate Yellow," the "Power Edge" and Cat "Modern Hex" trade dress as well as corporate and product identity used herein, are trademarks of Caterpillar and may not be used without permission.

QEHQ1848-02 (11-2022)
Build Number 01A

