



Cat[®] 272D2

SKID STEER LOADER

FEATURES:

The Cat[®] 272D2 Skid Steer Loader, with its long wheel base and vertical lift design, delivers extended reach and lift height for quick and easy truck loading. Its stability and lifting performance provides excellent material handling. The 272D2 features the following:

- **Industry leading sealed and pressurized cab option** provides a cleaner and quieter operating environment with excellent work tool visibility.
- **Available high-back, heated, air ride seat with seat mounted adjustable joystick controls** makes Cat Skid Steer Loaders the industry leader in operator comfort.
- **High performance power train** provides maximum performance and production capability through the Electronic Torque Management system, optional two speed travel and an electronic hand/foot throttle with decel pedal capability.
- **High Flow XPS hydraulic system** is available for applications that demand maximum hydraulic work tool performance.
- **Electronically controlled Cat C3.8 engine** provides high horsepower and torque while meeting U.S. EPA Tier 4 Final/EU Stage IV emission standards.
- **Cat "Intelligent Leveling" system (ILEV)** provides industry leading technology, integration and optional features such as dual direction self level, work tool return to dig and work tool positioner.
- **Speed Sensitive Ride Control option** improves operation on rough terrain, enabling better load retention, increased productivity and greater operator comfort.
- **Maximize machine capability and control** with the standard Advanced Display providing on-screen adjustments for implement response, hystat response and creep control. Also features multi-language functionality with customizable layouts, security system and rearview camera.
- **Ground level access** to all daily service and routine maintenance points helps reduce machine downtime for greater productivity.
- **Broad range of performance matched Cat Work Tools** make the Cat Skid Steer Loader the most versatile machine on the job site.

Specifications

Engine

Engine Model	Cat C3.8 DIT (turbo)	
Gross Power SAE J1995	73 kW	98 hp
Net Power SAE 1349	71 kW	95 hp
Net Power ISO 9249	71 kW	96 hp
Peak Torque at 1,500 rpm SAE J1995	334 N·m	246 lbf·ft
Displacement	3.8 L	232 in ³
Stroke	120 mm	4.7 in
Bore	100 mm	3.9 in

Weights*

Operating Weight	3977 kg	8,768 lb
------------------	---------	----------

Power Train

Travel Speed (Forward or Reverse):		
One Speed	10.6 km/h	6.6 mph
Two Speed Option	15.1 km/h	9.4 mph

Operating Specifications*

Rated Operating Capacity	1542 kg	3,400 lb
Rated Operating Capacity with Optional Counterweight	1656 kg	3,650 lb
Tipping Load	3084 kg	6,800 lb
Breakout Force, Tilt Cylinder	3376 kg	7,443 lb
Breakout Force, Lift Cylinder	2755 kg	6,074 lb

Hydraulic System

Hydraulic Flow – Standard:			
Loader Hydraulic Pressure	23 000 kPa	3,335 psi	
Loader Hydraulic Flow	86 L/min	23 gal/min	
Hydraulic Power (calculated)	33 kW	44 hp	
Hydraulic Flow – High Flow XPS:			
Maximum Loader Hydraulic Pressure	28 000 kPa	4,061 psi	
Maximum Loader Hydraulic Flow	121 L/min	32 gal/min	
Hydraulic Power (calculated)	57 kW	76 hp	

Cab

ROPS	ISO 3471:2008
FOPS	ISO 3449:2005 Level I
FOPS Level II	ISO 3449:2005 Level II

Service Refill Capacities

Chain Box, each side	10.2 L	2.7 gal
Cooling System	16 L	4.1 gal
Diesel Exhaust Fluid (DEF) Tank	19 L	5 gal
Engine Crankcase	13 L	3.5 gal
Fuel Tank	122 L	32.2 gal
Hydraulic System	55 L	14.5 gal
Hydraulic Tank	39 L	10.3 gal



272D2 Skid Steer Loader

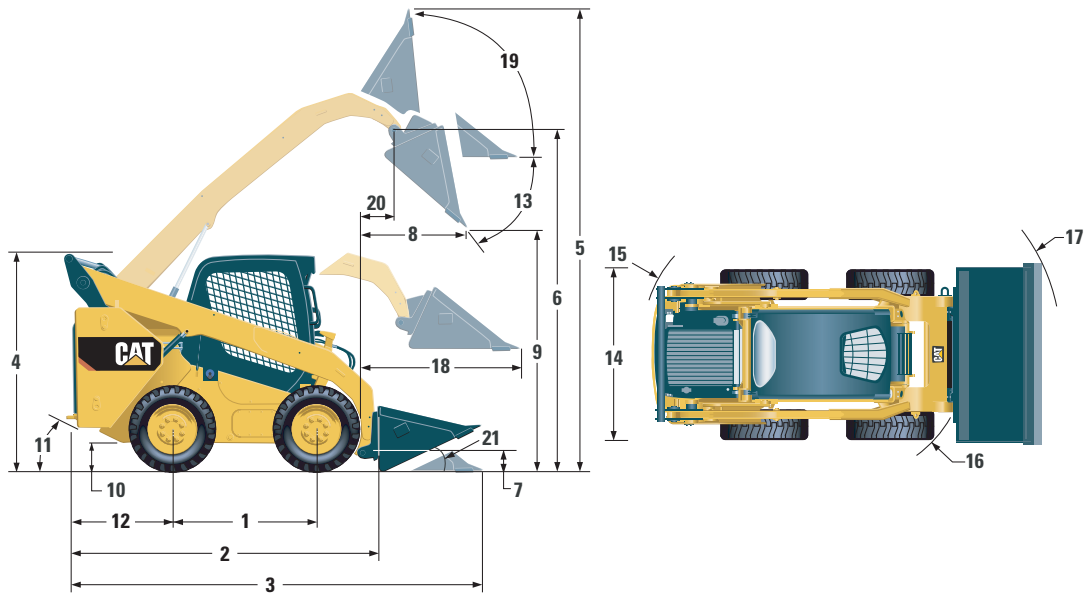

Dimensions*

1 Wheelbase	1386 mm	54.6 in	12 Bumper Overhang behind Rear Axle	1175 mm	46.2 in
2 Length without Bucket	3242 mm	127.6 in	13 Maximum Dump Angle		51°
3 Length with Bucket on Ground	3954 mm	155.7 in	14 Vehicle Width over Tires	1829 mm	72.0 in
4 Height to Top of Cab	2094 mm	82.4 in	15 Turning Radius from Center – Machine Rear	1899 mm	74.7 in
5 Maximum Overall Height	4067 mm	160.1 in	16 Turning Radius from Center – Coupler	1482 mm	58.3 in
6 Bucket Pin Height at Maximum Lift	3229 mm	127.1 in	17 Turning Radius from Center – Bucket (racked)	2280 mm	89.8 in
7 Bucket Pin Height at Carry Position	198 mm	7.8 in	18 Maximum Reach with Arms Parallel to Ground	1282 mm	50.5 in
8 Reach at Maximum Lift and Dump	769 mm	30.3 in	19 Rack Back Angle at Maximum Height		84°
9 Clearance at Maximum Lift and Dump	2438 mm	96.0 in	20 Bucket Pin Reach at Maximum Lift	374 mm	14.7 in
10 Ground Clearance	226 mm	8.9 in	21 Roll Back Angle		28°
11 Departure Angle		27°			

*Operating Weight, Operating Specifications and Dimensions all based on 75 kg (165 lb) operator, all fluids, one speed, enclosed cab with glass door, side windows, heater, mechanical suspension seat, advanced display, standard flow hydraulics, 880 CCA battery, 1829 mm (72 in) dirt bucket, no optional counterweights, Cat PC 12 x 16.5 tires and manual quick coupler (unless otherwise noted).

Noise Level

Inside Cab**	83 dB(A)
Outside Cab***	102 dB(A)

- Cab and Rollover Protective Structures (ROPS) are standard in North America and Europe.

**The declared dynamic operator sound pressure levels per ISO 6396:2008. The measurements were conducted with the cab doors and windows closed and at 70% of the maximum engine cooling fan speed. The sound level may vary at different engine cooling fan speeds.

***The labeled sound power level for the CE marked configurations when measured according to the test procedure and conditions specified in 2000/14/EC.

Air Conditioning System

The air conditioning system on this machine contains the fluorinated greenhouse gas refrigerant R134a (Global Warming Potential = 1430). The system contains 0.81 kg of refrigerant which has a CO₂ equivalent of 1.158 metric tonnes.

MANDATORY EQUIPMENT

- Hydraulics, Standard or High Flow XPS
- Quick Coupler, Mechanical or Powered
- Seat Belt, 50 mm (2 in) or 75 mm (3 in)
- Power Train: One Speed, Two Speed or Two Speed with Speed Sensitive Ride Control
- Tires, 12 × 16.5 or 14 × 17.5

PERFORMANCE PACKAGE *(must select one of the following)*

- Performance Package H1: *Standard Flow Hydraulics (No Self Level)*
- Performance Package H2: *Standard Flow, Dual Direction Electronic Self Level (Raise and Lower), Electronic Snubbing (Raise and Lower)*
- Performance Package H3: *High Flow XPS, Dual Direction Electronic Self Level (Raise and Lower), Electronic Snubbing (Raise and Lower)*

STANDARD EQUIPMENT

ELECTRICAL

- 12 volt Electrical System
- 100 ampere Alternator
- Ignition Key Start/Stop Switch
- Lights: *Gauge Backlighting, Two Rear Tail Lights, Two Rear Halogen Working Lights, Two Adjustable Front Halogen Lights, Dome Light*
- Backup Alarm
- Heavy Duty Battery, 880 CCA

OPERATOR ENVIRONMENT

- Gauges: *Fuel Level, DEF Level, Hour Meter*
- Operator Warning System Indicators: *Air Filter Restriction, Alternator Output, Armrest Raised/Operator Out of Seat, Engine Coolant Temperature, Engine Oil Pressure, Air Inlet Heater Activation, Hydraulic Filter Restriction, Hydraulic Oil Temperature, Park Brake Engaged, Engine Emission System*
- Adjustable Vinyl Seat
- Fold In Ergonomic Contoured Armrest
- Control Interlock System, when operator leaves seat or armrest raised: *Hydraulic System Disables, Hydrostatic Transmission Disables, Parking Brake Engages*
- ROPS Cab, Open, Tilt Up
- FOPS, Level I
- Top and Rear Windows
- Floor Mat
- Interior Rearview Mirror
- 12 volt Electric Socket
- Horn
- Hand (Dial) and Foot Throttle, Electronic with Decel Feature
- Adjustable Joystick Controls
- Advanced Display: *Full Color, 127 mm (5 in) LCD Screen, Advanced Multi-operator Security System, On-screen Adjustments for Implement Response, Hystat Drive Response and Creep Control*
- Storage Compartment with Netting

OPTIONAL ATTACHMENTS

- External Counterweights
- Beacon, Rotating
- Engine Block Heater – 120V
- Oil, Hydraulic, Cold Operation
- Paint, Custom
- Heavy Duty Battery, 880 CCA, with Battery Disconnect
- Heavy Duty Battery, 1,000 CCA, with Battery Disconnect

COMFORT PACKAGE *(must select one of the following)*

- Open ROPS (C0): *Static Seat (No Foot Throttle, Headliner, Heater or Door)*
- Open ROPS (C1): *Foot Throttle, Headliner, Cup Holder, and choice of Seat (Mechanical Suspension or High Back, Heated, Air Ride Seat) (No Heater or Door)*
- Enclosed ROPS with Heater (C2): *Foot Throttle, Headliner, Heater and Defroster, Side Windows, Cup Holder, Radio Ready, choice of Seat (Mechanical Suspension or High Back, Heated, Air Ride Seat) and Door (Glass or Polycarbonate)*
- Enclosed ROPS with A/C (C3): *C2 + Air Conditioner*

POWER TRAIN

- Cat C3.8, Turbo Diesel Engine, Meeting Tier 4 Final/Stage IV Emission Standards
- Air Cleaner, Dual Element, Radial Seal
- S-O-SSM Sampling Valve, Hydraulic Oil
- Filters, Cartridge-type, Hydraulic
- Filters, Cartridge-type, Fuel and Water Separator
- Radiator/Hydraulic Oil Cooler (side-by-side)
- Spring Applied, Hydraulically Released Parking Brakes
- Hydrostatic Transmission
- Four Wheel Chain Drive

OTHER

- Engine Enclosure, Lockable
- Extended Life Antifreeze, –37° C (–34° F)
- Machine Tie Down Points (6)
- Support, Lift Arm
- Hydraulic Oil Level Sight Gauge
- Radiator Coolant Level Sight Gauge
- Radiator, Expansion Bottle
- Cat ToughGuard™ Hose
- Auxiliary, Hydraulics, Continuous Flow
- Heavy Duty, Flat Faced Quick Disconnects with Integrated Pressure Release
- Split D-Ring to Route Work Tool Hoses Along Side of Left Lift Arm
- Electrical Outlet, Beacon
- Belly Pan Cleanout
- Variable Speed Demand Fan
- Product Link™ PL240, Cellular

- Product Link PL641, Cellular
- Variable Speed Demand Fan with Reversing Functionality
- Advanced Display: Rearview Camera Included
- Work Tool Return to Dig and Work Tool Positioner
- Bluetooth Radio with Microphone (AM/FM/Weather Band Receiver with USB and Auxiliary Input Jack)

272D2 Skid Steer Loader

For more complete information on Cat products, dealer services, and industry solutions, visit us on the web at www.cat.com

© 2017 Caterpillar
All rights reserved

Materials and specifications are subject to change without notice. Featured machines in photos may include additional equipment. See your Cat dealer for available options.

CAT, CATERPILLAR, SAFETY.CAT.COM, their respective logos, "Caterpillar Yellow" and the "Power Edge" trade dress, as well as corporate and product identity used herein, are trademarks of Caterpillar and may not be used without permission.

AEHQ7438-01 (06-2017)
Replaces AEHQ7438
(NACD, EU, ANZ)

