



Cat[®] AP1055F PAVER

FEATURES:

HIGH RETURN ON INVESTMENT

- Higher resale value: long-life components, and latest engine emissions technology
- Exclusive 70 kW integrated generator, designed for long life by the same team that developed the D7E electric drive dozer
- Fast heating screed leads to more daily production, heating time in as little as 15 minutes
- Mobil-trac™ undercarriage limits tow-point movement for excellent paving results
- Exclusive air flow design improves operating conditions for the crew and keeps components cooler for lasting durability

ADVANCED TECHNOLOGY

- Exclusive screed heating system monitors elements for failure conditions, eliminates unnecessary replacement
- Cat[®] Grade and Slope option integrated in the tractor and screed displays for optimized operator efficiency
- Propel and feeder system settings transfer between stations with a single switch; Cat exclusive
- Auto-fill feeder system simplifies setup
- Single touch feeder system activation optimizes efficiency
- Automated travel feature; augers and hydraulic mainframe extensions raise with the screed, preventing damage during transport
- Product Link™ remotely monitors machine location, daily hours of operation, fuel consumption, fault codes, and preventative maintenance status, for optimal machine support

HIGH QUALITY RESULTS, HIGHER EARNINGS

- SE60 XW screeds deliver excellent ride, density, and mat texture while providing superior adjustment capabilities up to 10 m (33')
- SE60 V screed delivers great ride and mat qualities while providing versatility in urban areas as well as interstate applications
- Tow-point utilizes exclusive linkage design for optimal screed flotation
- Exclusive 2-speed proportional control on the screed extenders

LOW OWNING AND OPERATING COSTS

- Exclusive Eco-mode and Automatic Engine Speed Control reduce fuel consumption and lower sound levels for better comfort and communication
- 4-pump feeder system is designed for high production in Eco-mode, leads to lower fuel consumption
- Keypad switches have been tested to 1-million cycles without failure
- Conveyor bed plates and chain guards designed to minimize labor requirements and provide lower cost replacement
- Heating elements slide-out for easy replacement
- Machined screed frames simplify screed plate replacement

UNMATCHED AFTER-THE-SALE SUPPORT

- Strategically located dealers with 24/7 support
- In-the-Iron service training for technicians
- Paver Operator Training helps maximize machine performance
- Project consulting helps improve technique and job site management

Specifications:

Engine – Powertrain

Cat C7.1 ACERT™ Engine			
Australia, U.S., and Canada*	168 kW	225 hp	
* Engine meets U.S. EPA Tier 4 Final/E.U. Stage IV emission standards.			
Cat C7.1 Engine			
China, Middle-East, Russia, South America**	186 kW	249 hp	
** Engine meets emissions equivalent to U.S. EPA Tier 3 and E.U. Stage IIIA requirements.			
Number of cylinders	6		
Engine speed - maximum/minimum	2200/1100 rpm		
Eco-mode	1650 rpm		
Screed heating - standard width (Quiet)	1300 rpm		
Screed heating - w/extensions (Quick)	1300 to 2200 rpm		
Speed ranges:			
Paving	70 mpm	230 fpm	
With Tamper-bar screed	25 mpm	82 fpm	
Travel	14.5 km/hr	9 mph	

Weights - Australia, U.S. and Canada

AP1055F (tractor only - shipping)	16 691 kg	36,804 lb
AP1055F (tractor only - operating)	17 031 kg	37,553 lb
AP1055F with SE60 V screed	20 452 kg	45,090 lb
AP1055F with SE60 V XW screed	21 128 kg	46,580 lb
AP1055F with SE60 VT XW screed	21 918 kg	48,320 lb

Weights - China, Middle-East, Russia, South America

AP1055F (tractor only - shipping)	16 716 kg	36,852 lb
AP1055F (tractor only - operating)	17 355 kg	38,261 lb
AP1055F with SE60 V screed	20 618 kg	45,455 lb
AP1055F with SE60 V XW screed	21 128 kg	46,580 lb
AP1055F with SE60 VT XW screed	21 918 kg	48,320 lb

Operating weights include full fuel tank and 75 kg (165 lb) operator.



AP1055F Specifications

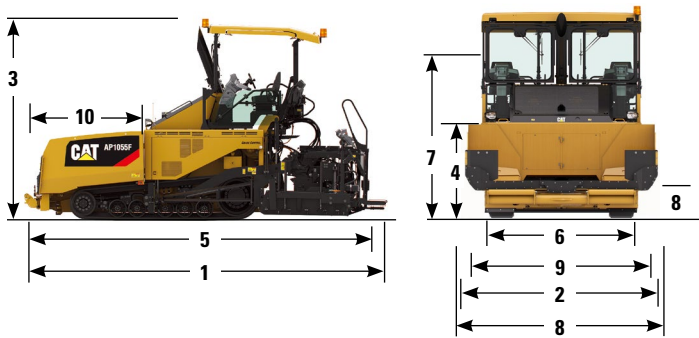

Dimensions:

1	Operating length with SE60 V screed	6840 mm	22' 5"
	Operating length with SE60 V XW, VT XW screed	7030 mm	23' 1"
	Operating length without screed	5609 mm	18' 5"
2	Operating width – standard entry hopper	3350 mm	11' 0"
	Operating width – low entry hopper	3604 mm	11' 10"
3	Operating height with canopy, (top of beacon)	4000 mm	13' 1"
	Operating height without canopy	3715 mm	12' 2"
4	Operating deck height	1791 mm	5' 11"
5	Transport length with SE60 V screed	6710 mm	22' 0"
	Transport length with SE60 V XW, VT XW screed	6900 mm	22' 8"
6	Transport width - with endgates	3211 mm	10' 6"
	Transport width - endgates folded	3000 mm	9' 10"
7	Transport height - canopy retracted	3060 mm	10'
	Transport height - without canopy	2930 mm	9' 7"
8	Truck entry height with standard entry hopper		
	Manual apron	570 mm	22.5"
8	Hydraulic apron	616 mm	24"
	Truck entry height with low entry hopper		
8	Manual apron	521 mm	20.5"
	Hydraulic apron	587 mm	23"
9	Truck entry width - standard entry hopper	3224 mm	10' 7"
	Truck entry width - low entry hopper	3490 mm	11' 6"
10	Hopper length with pushroller - minimum	2414 mm	7' 11"

Screed Specifications

Standard paving range	3.0 - 5.95 m	10' - 19' 6"
Maximum paving width with extensions	10 m	33'
Maximum paving depth	305 mm	12"
Crown range - SE60 V, V XW*	-3% to +10%	
SE60 VT XW**	-1.5% to 5%	
Extender height range	-20 mm to + 50 mm	
Extender slope range	-3% to +10%	

* Scale indicator represents total crown for the screed.

** Scale indicator represents crown for each side of the screed.

Note: Total crown capability is the same for both vibratory and tamper bar screeds.

Electrical System

Starting and Charging	24-volt
Alternator	115 amp
Batteries	Two, 1400 CCA
Generator	70 kW
Auxiliary power capability	6.6 kW
Machine Security System	Wire-ready
Product Link System	Wire-ready
Remote jump-start	Yes
Cat Grade and Slope	Integrated

Capacities

Maximum throughput capacity	1602 tonnes/h	1,766 tph
Hopper capacity with tunnels		
Standard entry hopper	7.6 m ³	267 ft ³
Low entry hopper	8.1 m ³	286 ft ³
Fuel tank	348 L	92 gal
DEF (Urea) capacity	19.1 L	5 gal
Cooling system	45.4 L	12 gal
Engine oil	16 L	4.2 gal
Hydraulic tank	219 L	58 gal

Optional Equipment

- Air-ride Seat w/Heat
- Auger and Mainframe Extensions
- Ballast (front bumper)
- Cat Grade and Slope Controls
- Decelerator Pedals
- Ecological Washdown System
- Feeder Sensor (mechanical or sonic)
- Friction Steering
- Hard Top Canopy
- HID Lights
- Leveling Devices
- Lights (Working or Roading)
- Smooth/treadbar belt
- Oscillating Push Roller
- Power Folding Front Apron
- Power Mainframe Extensions
- Product Link
- Tow-point Indicators (Upper)
- Track Plow
- Truck Hitch
- Umbrella
- Up-time Kit
- Warning Beacon
- Wide Width Paving Packages
- Windshield w/hard top canopy

Materials and specifications are subject to change without notice.

Featured machines in photos may include additional equipment.

For more complete information on Cat products, dealer services, and industry solutions, visit us on the web at www.cat.com

©2017 Caterpillar Inc.

All Rights Reserved.

CAT, CATERPILLAR, ACERT, SAFETY.CAT.COM, their respective logos, "Caterpillar Yellow" and the "PowerEdge" trade dress, as well as corporate and product identity used herein, are trademarks of Caterpillar and may not be used without permission.

Product ID: AP1055F

QEHQ1817-06 (9-2017)

