

Installation Manual

415GM

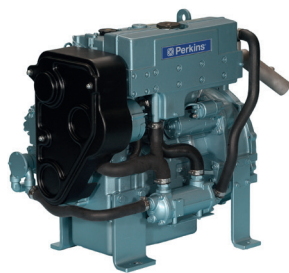

422GM



422TGM

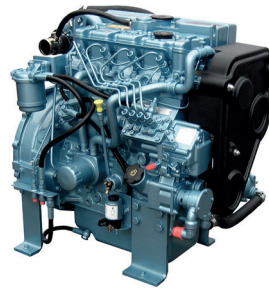

700GM



4.4GM



4.4TGM



**4.4TWGM &
4.4TW2GM**



4GM

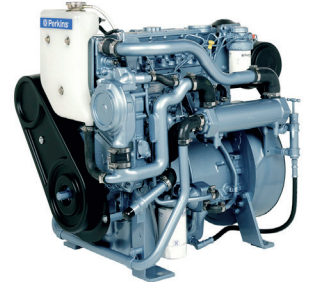

4TGM

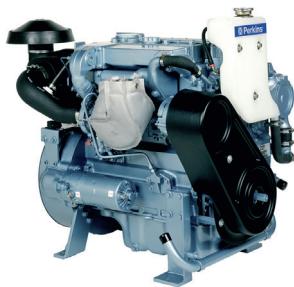

6TG2AM



6TWGM



4.4GM Radiator

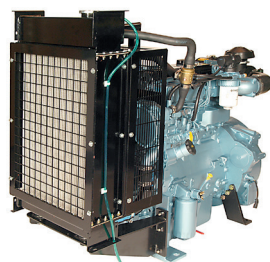

**4.4TWGM &
4.4TW2GM Radiator**

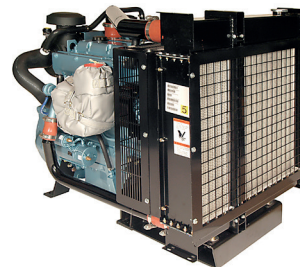

Perkins Marine Auxiliary Engines Installation Manual

415GM

422GM

422TGM

700GM

4GM

4TGM

4.4GM

4.4TGM

4.4TWGM

4.4TW2GM

6TG2AM

6TWGM

4.4GM Radiator

4.4TWGM Radiator

4.4TW2GM Radiator

Introduction

The aim of this publication is to provide information in the form of technical data and installation guidance, enabling auxiliary engines to be installed in a manor which will ensure safety, reliability and ease of servicing.

Introduction.....	4
Engine room ventilation.....	1
Radiator Cooling:	2
Exhaust systems	7
Wet Systems	7
Water lift systems	8
Syphon break.....	9
Part wet/part dry systems.....	10
Water separator	11
Dry systems	12
Fuel systems.....	15
Fuel connections	15
Fuel connections - 415GM, 422GM, 422TGM & 700GM	15
Fuel connections - 4GM, 4TGM 4.4GM, 4.4TGM, 4.4TWGM, 4.4TW2GM, 6TG2AM 6TWGM & Radiator Versions.....	15
Fuel tank connections.....	16
Typical fuel systems.....	16
Raw water systems	19
Keel cooling or skin cooling.....	21
Sizing the coolers.....	21
Keel cooling connections- 415GM, 422GM & 422TGM.....	23
Keel cooling connections - 700GM.....	24
Keel cooling connections - 4GM and 4TGM.....	25
Keel cooling connections - 4.4GM and 4.4TGM.....	26
Keel cooling connections - 4.4TWGM and 4.4TW2GM.....	27
Keel cooling connections - 6TG2AM	28
Keel cooling connections - 6TGWM	29
De-aeration.....	30
Radiator cooled	30
Expansion Tank	30
Engine bleed (Vents)	30
Remote expansion tank - 4.4GM, 4.4TGM & 4.4TW2GM	32
Power take-off (not optional on the 415GM, 422GM & 422TGM). 39	
PTO Fitting Instructions.....	39
Belt drives - 4.4GM, 4.4TGM, 4.4TWGM and 4.4TW2GM only.....	40
Belt drives - 700GM only.....	41
Belt drives - 4GM and 4TGM only.....	42
Belt drives - 6TG2AM and 6TWGM only.	43

Electrical system	45
Electrolytic corrosion.....	45
Definition of galvanic and electrolytic corrosion.....	45
Avoiding electrolytic corrosion.....	45
Zinc Anode bonding system	46
Battery and starter cables	46
Other electrical features 415GM, 422GM & 422TGM	48
APECS calibration tool (ACT) part number 36204.....	50
Electronic governor overview	51
Electronic governor in detail	52
Controller installation and wiring diagram	52
Controller wiring table	53
System wiring.....	53
Other electrical features 700GM.....	54
APECS calibration tool (ACT) part number 36204.....	56
Electronic governor overview	57
Electronic governor in detail	58
Controller installation and wiring diagram	58
Controller wiring table	59
System wiring.....	59
Other electrical features 4GM & 4TGM.....	60
L Series electronic governor guidelines	61
Other electrical features 4.4GM, 4.4TGM, 4.4TWGM & 4.4TW2GM	62
Standard control system (optional on 4.4 range).....	64
Voltage Converter Fitting Instructions	64
For the 4.4 range of engines supplied without a loom	65
Other electrical features 6TG2AM.....	66
Other electrical features 6TWGM.....	67
Electronic governor.....	68
6TWGM from March 2014.....	70
L Series electronic governor guidelines	70
Data - 415GM.....	71
Data - 422GM.....	73
Data - 422TGM.....	75
Data - 700GM.....	77
Data - 4GM.....	79
Data - 4TGM.....	81
Data - 4.4GM.....	83
Data - 4.4TGM.....	85
Data - 4.4TWGM	87
Data - 4.4TW2GM	89
Data - 6TG2AM	91
Data - 6TWGM	93
Data - 4.4GM Radiator	95
Data - 4.4TGM Radiator.....	97
Data - 4.4TWGM Radiator.....	99
Data - 4.4TW2GM Radiator.....	101

Engine room ventilation

The engine room must be ventilated for two reasons:

- To supply the engine with air for combustion.
- To provide a flow of air through the engine room to prevent an excessive temperature build up, which may cause components such as the generator to overheat.

In most applications in temperate climates, the engine will draw air from the engine room. If this is the case then, as a rough guide, it can be taken that every horsepower produced by the engines requires, as a minimum, 0.25 sq.ins. of vent area. If the boat is likely to be used in hot climates, and if engine room ventilation fans are fitted, then a vent area of 0.5 sq.ins. per horsepower should be provided, (see the table below). Wherever possible a flow of air through the engine room should be encouraged by using forward facing intake vents to take advantage of ram airflow, together with other vents to allow hot air to escape.

With an effective ventilation system the engine air intake temperature will be no more than 10 Centigrade degrees higher than the outside air temperature.

Minimum cross section of air duct per engine		
Engine	For hot climates	For temperate climates
415GM	103sq.cm (16sq.ins)	52sq.cm (8sq.ins)
422GM		
422TGM		
700GM	135sq.cm (21sq.ins)	71sq.cm (11sq.ins)
4GM	200sq.cm (31sq.ins)	103sq.cm (16sq.ins)
4TGM	348sq.cm (54sq.ins)	174sq.cm (27sq.ins)
4.4GM	213sq.cm (33sq.ins)	106sq.cm (16.5sq.ins)
4.4TGM	275sq.cm (42.6sq.ins)	139sq.cm (21.5sq.ins)
4.4TWGM	358sq.cm (55.5sq.ins)	181sq.cm (28sq.ins)
4.4TW2GM	474sq.cm (73.5sq.ins)	240sq.cm (37sq.ins)
6TG2AM	477sq.cm (74sq.ins)	240sq.cm (37sq.ins)
6TWGM	626sq.cm (97sq.ins)	316sq.cm (49sq.ins)
4.4GM Radiator	For radiator cooled engines, the air flow requirements for engine room ventilation are provided by the air flow through the radiator. Air ducting for radiator cooled engines must be given great design consideration. The radiators are design to have a maximum duct restriction of 200Pa. Duct design should ensure this pressure limit is not exceeded. The radiator air volume flows are given in the data section at the back of this manual.	
4.4TGM Radiator		
4.4TWGM Radiator		
4.4TW2GM Radiator		
Note: This is in addition to the ventilation needs of the main propulsion engines.		

Radiator Cooling:

Note: Only flexible ducts to be used on the front of the radiator.

Note: Ducting or duct-work should not be hard mounted to the genset or radiator. The genset is fitted with flexible mounts and therefore is able to vibrate and slightly move in operation. A flexible compensation section should be used in any duct which is fitted to the genset or radiator, in order to take up slight movements without causing undue stress to either the duct-work or genset components.

The radiator cooling pack option uses air to cool the engine, rather than sea water. As such a good supply of air is vital to achieving the correct cooling performance. Not only is the supply of air important but so is the exhaust of air from the radiator. The complete air circuit must be given great consideration to achieve the correct cooling performance.

Illustration A shows the cooling air circuit. Although the exact details of the layout will need to vary from installation to installation, the basic air circuit will remain the same. The marine genset utilises a pusher fan, which draws cooling air from the inlet (A2) over the generator and engine (A1), and then pushes through the radiator and charge air cooler. Typically the exhaust from the radiator and charge air cooler then exit the engine room via a vent to outside (A3). Cool air enters the engine room from outside through another set of vents.

The radiator cooling system is designed for a maximum air temperature behind the genset of 50°C. The design accounts for the radiated heat from the engine and generator which will lead to air temperatures greater than 50°C at the inlet to of the radiator fan. The design does not account for any other heat sources in the engine bay. If other sources of heat are present then additional ventilation will need to be considered. This is especially important for gensets likely to operate in hotter climates.

The radiator cooling system is designed to operate with a maximum duct restriction pressure of 127Pa (0.5 in H₂O). The pressure is measured from a location in-front of the fan (typically along the length of the engine) to a location directly in-front of the radiator outlet, illustrations (B3) and (C). In this way the total pressure over the cooling pack(B2) is measured, including both the restrictions encountered in drawing the air into the engine and the restriction encountered in air exiting the engine room. When designing the engine room ventilation a pressure restriction target of 63.5Pa should be aimed for, although lower is better.

In order to measure the duct restriction of an installation, static pressure tubes will be required. Use of any other means is likely to give inaccurate results. A water manometer (B4) is normally sufficient for measuring the pressure. The static tube should be aligned parallel with the air flow. A fine thread on a stick is a useful tool in identifying the direction of air flow over the engine. (Care should be taken to keep it away from rotating parts, including the fan) Illustrations B and C shows typical locations of the static tubes used for taking pressure readings.

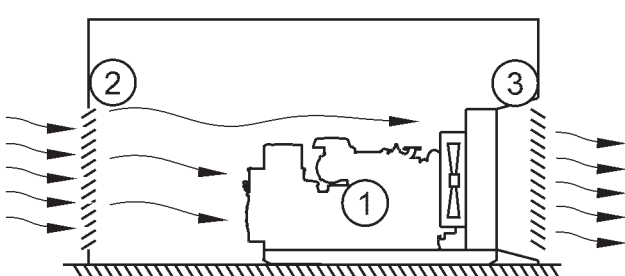

A

Illustration IM7179

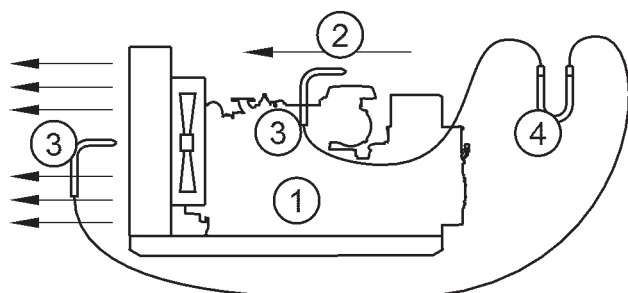

B

Illustration IM7180

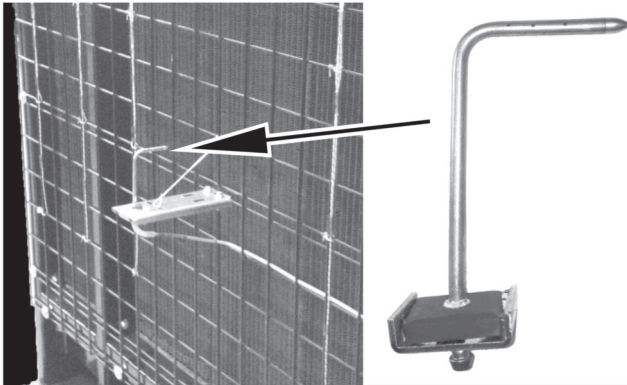

C

Illustration IM7182

Air Flow Measurements

- 1 Width.
- 2 Height.
- 3 Air flow.

An alternative to taking pressure measurements is to measure the air flow through the radiator. This can be done using an anemometer to measure the air velocity through an opening of known area, from which the volumetric flow can be calculated. As air density decreases with temperature, to get an accurate reading air flow measurements should be taken with the generator running, but at no load, such that there is minimum heating of the air flow.

Anemometers are specifically available for ventilation and duct work, an instrument of this type should be used where possible. Measurements should be made where air flow is uniform, ideally just after the radiator outlet, but not after any louvers, bends or obstructions which could lead to non-uniform air velocities. An accurate measurement of volumetric flow is best made by taking at least twelve air velocity readings across the opening.

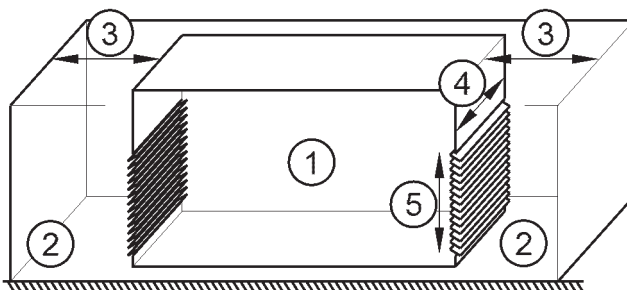

D

Illustration IM7181

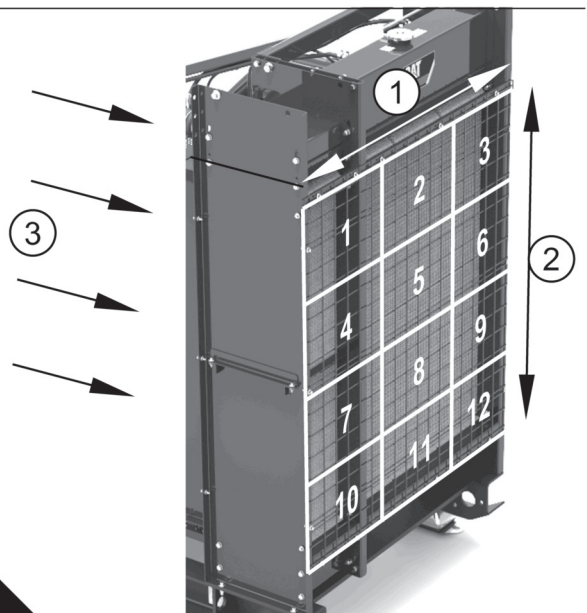

E

Illustration IM7184

It is best to draw up a grid with each cell being of equal area. Air velocity readings are then averaged, to give a total average air velocity through the opening. This is then multiplied by the opening area to give the volumetric air flow.

Illustration (E) shows the layout of the grid for calculating the volumetric flow

TMI contains air flow data for the fans fitted to CAT generator sets along with the restriction curves for radiator cores. Overlaying the two curves will give the operating volumetric air flow at the curve intersection point. If the air flow is measured then the total pressure across the fan can be measured of the fan curve. Given the air flow reading, the pressure drop can also be read off the radiator restriction curve. The difference in the two pressures is the total duct restriction present within the air system.

Volumetric Flow is given by:

- $Q = h \times w \times v_m$
- $v_m = (v_1 + v_2 + v_3 + v_4 + \dots + v_{12}) / 12$

Where:

- V_{1-12} : Air velocity readings 1->12 (m/s or ft/min)
- v_m : Average air velocity (m/s or ft/min)
- h : Opening height (m or ft)
- w : Opening width (m or ft)
- Q : Air volumetric flow (m^3/s or cfm)

Whilst taking pressure and air flow measurements can be useful verification methods, good design practice should be used to correctly size and locate inlet and exhaust vents. The biggest restriction around the air circuit is likely to be due to the inlet and exhaust vents themselves. As such the supplier of the vents should be consulted for correct sizing. Other good practices include:

- Exhaust pipes should be lagged, right from the turbine outlet. The lagging should be sufficient to ensure that the external surface temperature does not exceed $220^{\circ}C$ at full load. This helps to ensure that no extra heat is carried into the radiator air.
- Exhaust routing should, where possible, be away from the radiator so that the air flow into the radiator is not impeded.
- Ensure there is sufficient space in front and behind of any exhaust or inlet vent (see illustration (D), this includes:
 - Fire / heavy weather hatches should be able to fully open away from the vent.
 - Placing the vent such that a bulkhead is not immediately in front or behind the opening.
 - A suggested clearance between the vent and any bulkhead or otherwise is at least the longest of the height or width of the vent itself.
- Inlet air vents should be placed such that they pick up cool ambient air, not air which has picked up any additional heat, such as air exhausted from another engine room.
- The exhaust vent should have a frontal area equivalent to the total radiator exit area and ideally the same dimensions. If this cannot be achieved then tapered ductwork should be used to adapt the two together. A minimum length of 1m (3' 3") is recommended for any adapting ductwork, where a significant dimension change needs to take place.

Illustration D shows the basic considerations for allowing the genset to cool and breath.

1 Engine room.

2 Vents.

3 *D_M: minimum distance.

4 V_w: vent width.

5 V_H: vent height.

*D_m should meet the following conditions:

$$D_m \geq V_w$$

and

$$D_m \geq V_H$$

Power Variability

All engines are subject to variability of power output dependant on various external factors. Two of these factors with high significance are inlet air and fuel. Inlet air is largely affected by temperature, with atmospheric pressure variation being minor for marine sea-level installations. Diesel engines inject fuel by volume, and as such density changes vary the mass of fuel being injected.

The graphs below show the variation on engine power output based on changes to air inlet temperature and fuel density. The power output change with fuel is the same across all engines regardless of cooling system. The power output change with inlet air temperature does however depend on the charge air cooling method. Engines using an air to water cooler, Heat Exchanged and Keel Cooled, have less variation. This is due to the water being a more stable heat-sink, with resulting inlet manifold air temperatures being stable also. Air to air cooling methods, Radiators, are less stable with the ambient air being used to cool the charge air, leading to high output variability.

CAT engines have their rated power defined at standardised conditions; typically these are 25°C air and 850 kg/m³ fuel. As such operating in conditions away from these will likely cause engine power output to drop. This should be born in mind when designing engine room ventilation, so that ambient air temperatures are kept to a minimum.

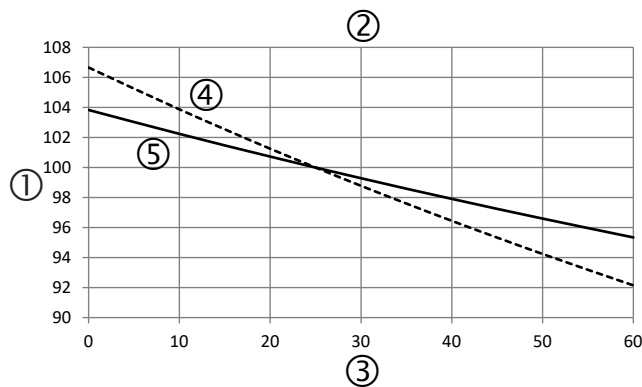

1 Power adjustment - %.

2 Engine power adjustment by ambient temperature. SAE J1995 rating standard.

3 Ambient temperature.

4 Radiator.

5 Heat exchanger & keel cooled.

$$6 P_{\text{Baro}} = 100 \text{ kPa}$$

$$7 P_{\text{vap}} = 1 \text{ kPa}$$

$$8 F_m = 0.614 \text{ (engine factor).}$$

9 Turbocharged engines only.

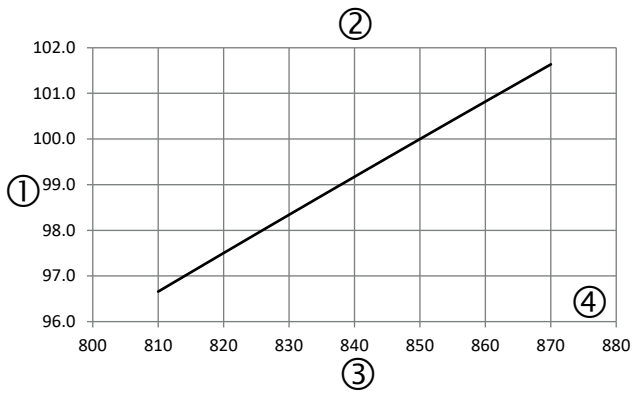

1 Power adjustment - %.

2 Engine power adjustment by fuel density. SAE J1995 rating standard.

3 Fuel density - kg/m³.

4 All cooling options.

Exhaust systems

The exhaust system should conduct exhaust gases from the engine to the atmosphere with acceptable back pressure at the same time reducing exhaust noise to the minimum, avoiding gas leaks and excessive surface temperatures while accommodating engine movement on flexible mounts.

There are two types of systems used, wet and dry.

Caution: *In all types of exhaust system, when measured within 305mm (12 inches) of the exhaust outlet from the engine, the exhaust back pressure must not exceed the amount stated in the relevant data section at the back of this manual*

Wet Systems

Wet exhaust systems, where the raw water used to circulate through the heat exchangers on the engine is finally injected into the exhaust pipe to cool the exhaust gases, are the most common choice for small craft. Their principal advantage is that a rubber exhaust hose may be used, with a fairly low surface temperature, which presents no risk of fire.

A general arrangement for such a system is shown on (A). In many cases the exhaust outlet passes through the transom, just above the waterline (A1). It will be seen that a minimum fall of 10 degrees is required (A2), and that the point of water injection must be at least 200mm (8 inches) above the waterline (A3), although the actual height necessary for a particular boat can only be decided in the light of the exhaust system design, and the pitch and roll which may be encountered in service.

Caution: *It is essential that the exhaust system is designed so that water from the exhaust does not enter the engine under any conceivable operational condition.*

Exhaust pipes			
Engine model	Exhaust bore	Engine mode	Exhaust bore
415GM	50mm (2.0ins)	4.4GM & Rad.	76mm (3.0 ins)
422GM		4.4TGM & Rad.	
422TGM		4.4TWGM & Rad.	
700GM	63.5mm (2.5ins)	4.4TW2GM & Rad.	100mm (4.0ins)
4GM	76mm (3ins)	6TG2AM	
4TGM		6TWGM	

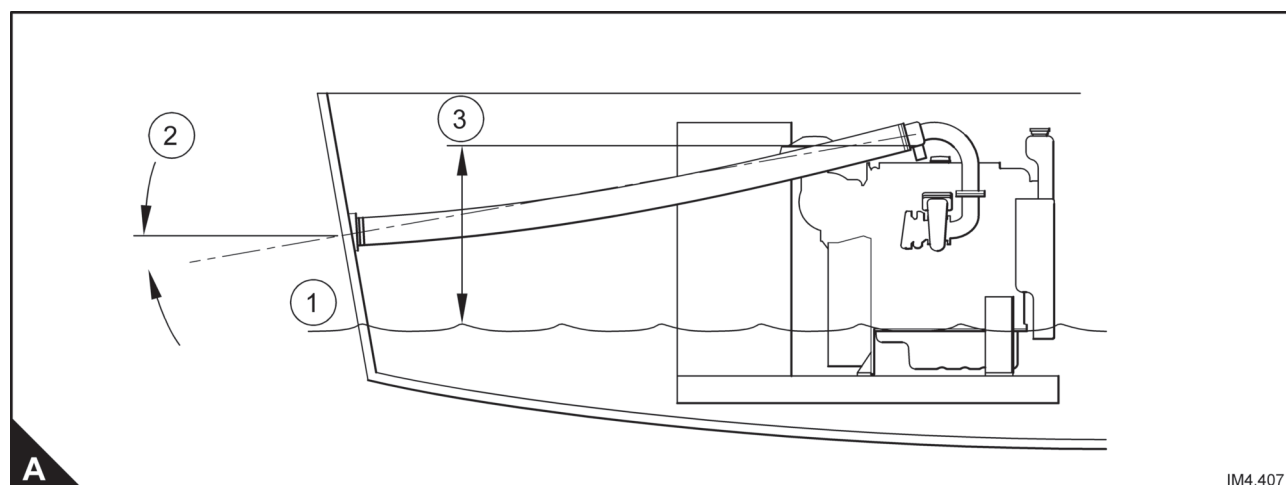

A

IM4.407

Water lift systems

For applications where the engine is installed below the water line, and in any installations where it is possible for water from the exhaust pipe to run back into the engine there are a number of solutions which can be considered.

In sailing yachts and deep draught displacement boats it may be found that the engine exhaust outlet is near or below the waterline, a water lift exhaust system is then an option that may be considered.

The main features of such a system are shown in (B). Pressure developed by the exhaust gases force a mixture of gas and water to a height which may be considerably above the engine. When the engine is stopped the exhaust tank (B1) contains the water which falls back from the exhaust riser (B2).

If a commercially available unit is used the manufacturers instructions should be carefully followed, but the key features are shown in (B).

The exhaust muffler/water lift (B1) should have a minimum volume equal to 3 times the volume of the water that could be contained in the exhaust riser (B2). On sailing craft the muffler/water lift should be installed near the centre-line of the vessel.

Particular care should be taken to prevent water from siphoning into the system and then flooding the engine. There are two routes by which this could happen; from the exhaust outlet or by the sea water feed to the engine.

The top of the exhaust riser (B3) should be a minimum of 450mm (18 inches) above the static water-line (B7), and the exhaust outlet (B4) should either be well above the static water level, or a siphon break should be fitted at (B5).

The exhaust system may also become flooded by water entering through the sea water system on the engine, as the sea water pump impeller can not be relied upon to seal when stationary. To prevent such flooding the above system should be implemented.

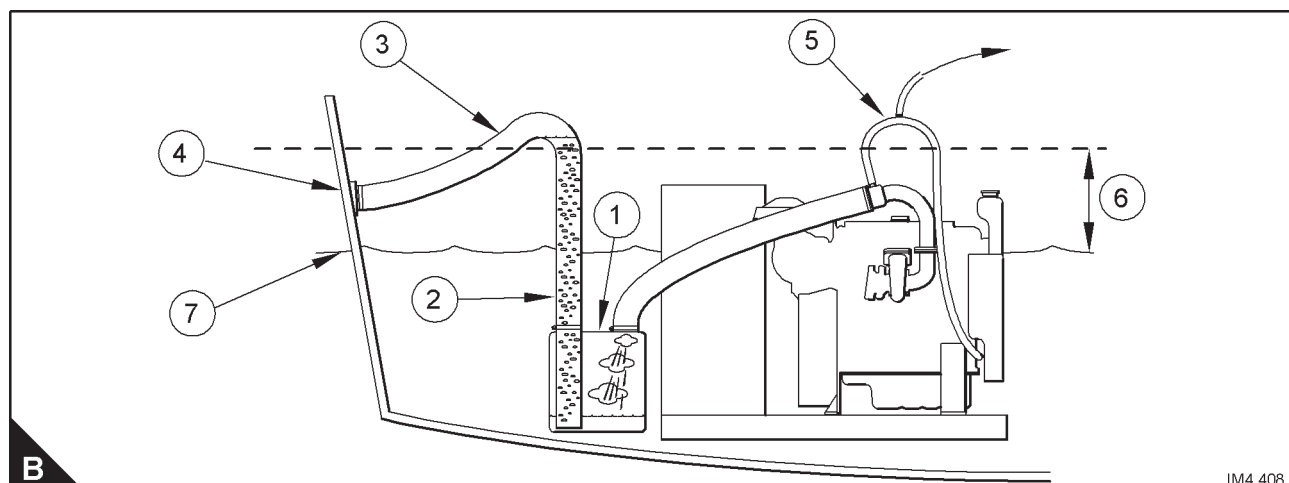

Syphon break

A syphon break admits air to the top of any 'inverted U bend and prevents unwanted syphonic action.

The syphon break should vent through a skin fitting well above the water level.

Some commercially available syphon break units contain a valve to prevent water loss through the vent pipe and vent within the vessel.

Note: Syphon breaks with a valve requires periodic maintenance, checks should be carried out every time the engine oil is changed.

Caution: Do not overcrank your engine when it will not start or crank the engine to bleed the fuel system, as there will not be the exhaust gas present to empty the exhaust riser. Water fills the riser and can back up the exhaust and fill the engine. The seacock must be closed and raw water pump impeller removed if the engine is to be cranked for more than one minute. Remember to replace the impeller and open the seacock when finished.

Top of the exhaust riser and the point at which the syphon break (C1) is connected to the engine pipework must be above the water line (C6) under the worst possible conditions (normally a distance of 450mm (18 inches) (C2) under static conditions will be sufficient). There should be a minimum distance of 300mm (12 inches) (C3) between the exhaust tank inlet (C4) and the water injection elbow (C5).

Note: Minimum volume of exhaust muffler/water lift should be three times the volume of the water in the riser. The tank should be installed near the centre-line of sailing craft.

Warning! Sea water inlet fittings with a scoop must not be used. The pressure generated when the vessel is under way can force the water past the raw water pump when the generator is not in operation, thus allowing water to fill up the water lift. With no exhaust pressure to force the water out of the system, water can enter the engine via the exhaust manifold.

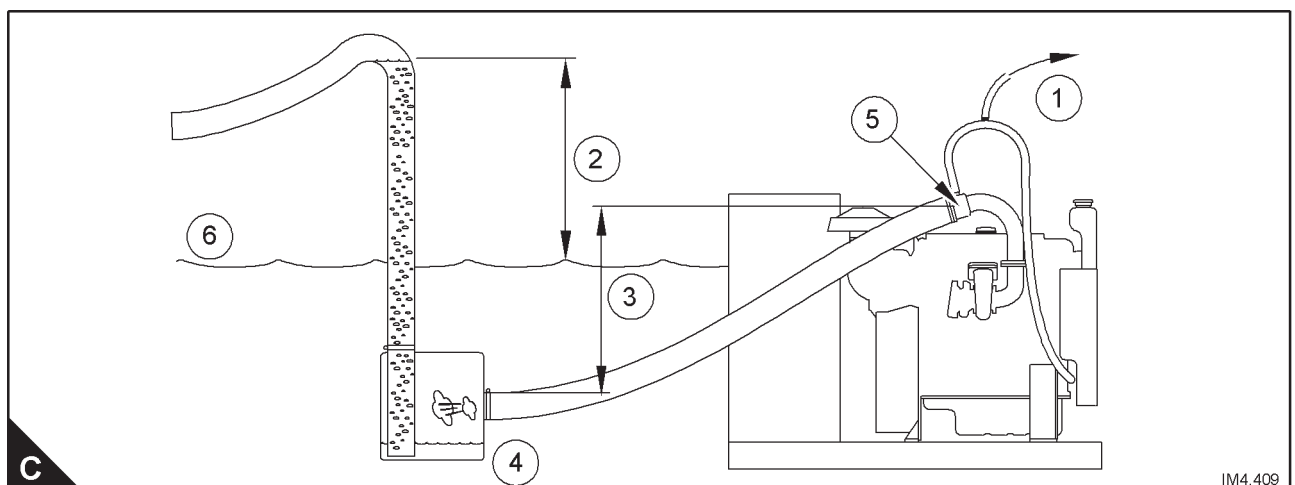

Part wet/part dry systems

In some installations this arrangement may be chosen in place of a water lift. The part wet/part dry system allows the engine exhaust manifold outlet to be near or below the waterline, and provides protection against sea water back-flooding into the engine exhaust.

The general arrangement (D) shows that the dry part of the system extends to a safe height above the water line, using an elbow (D1), a stainless steel bellows (D2), a riser pipe to give the required height (D3), and a further elbow (D4), which is supported from the deck head by a flexible hanger (D5), which supports the weight of the system but permits movement side to side and fore and aft.

At this point water is injected into the exhaust through the injection elbow (D6), and the remainder of the system follows usual wet exhaust practice, with a rubber hose falling to a transom fitting.

The point of water injection should be at least 200mm (8") above the water-line (D7), and the wet exhaust should have an average fall of at least 10°. The table below shows the recommended minimum sizes.

Model	Minimum diameter of dry part of exhaust system	Minimum diameter of wet part of exhaust system
415GM	40mm (1.6ins)	51mm (2ins)
422GM		63.5mm (2.5ins)
422TGM		
700GM		
4GM	60mm (2.36ins)	76mm (3ins)
4TGM		
4.4GM & Rad		
4.4TGM & Rad		
4.4TWGM & Rad.	76mm (3ins)	102mm (4ins)
4.4TW2GM & Rad.		
6TG2AM		
6TWGM		
	The dry part of the system should be insulated to avoid excessive heat loss to the engine compartment.	

Note: The bellows should be in an unstrained condition when installed, so that the full bellows movement is available to absorb expansion and engine movement. The weight of the exhaust system should be supported by brackets, and not carried by the bellows.

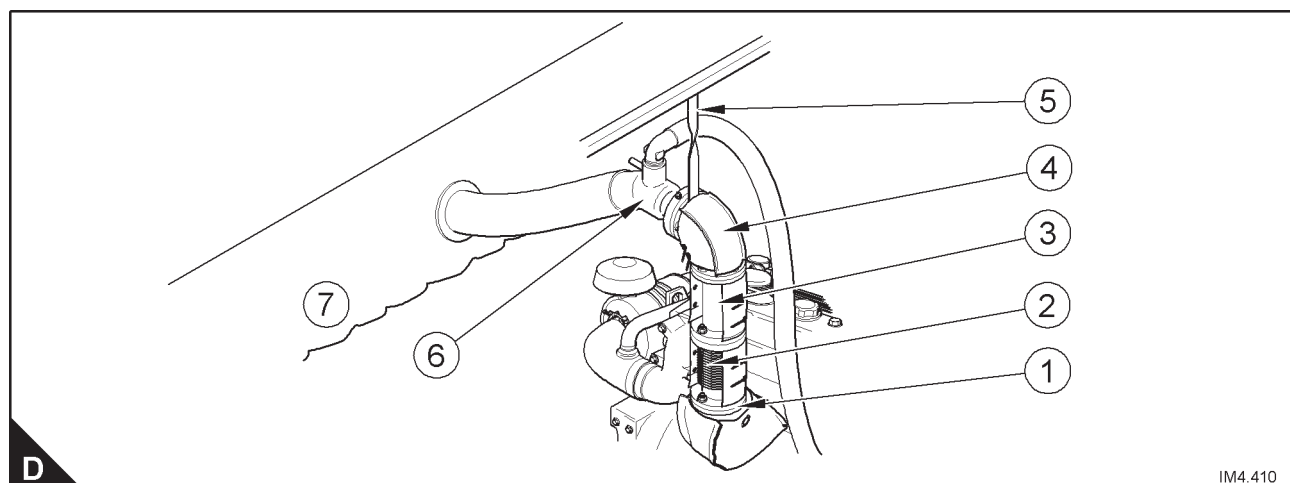

IM4.410

Water separator

The benefit of a water separator (E1) in addition to a water lift silencer, is that it separates the water from the water/gas mix and discharges below the waterline (E3) thus avoiding the often irritating spluttering noise associated with water cooled generators, especially in a quiet marina. A water separator also reduces exhaust back pressure in long exhaust runs.

Warning! *Sailing yachts can present special problems when considering the amount of heel and therefore care must be taken when designing the system.*

When designing the exhaust system for sailing yachts the predicted heel and any engine installation offset from the centreline must be taken into account.

The designer may include in the system a gate valve or sea cock (E2), if there is any likelihood of the engine being at risk in extreme heel conditions as a precaution.

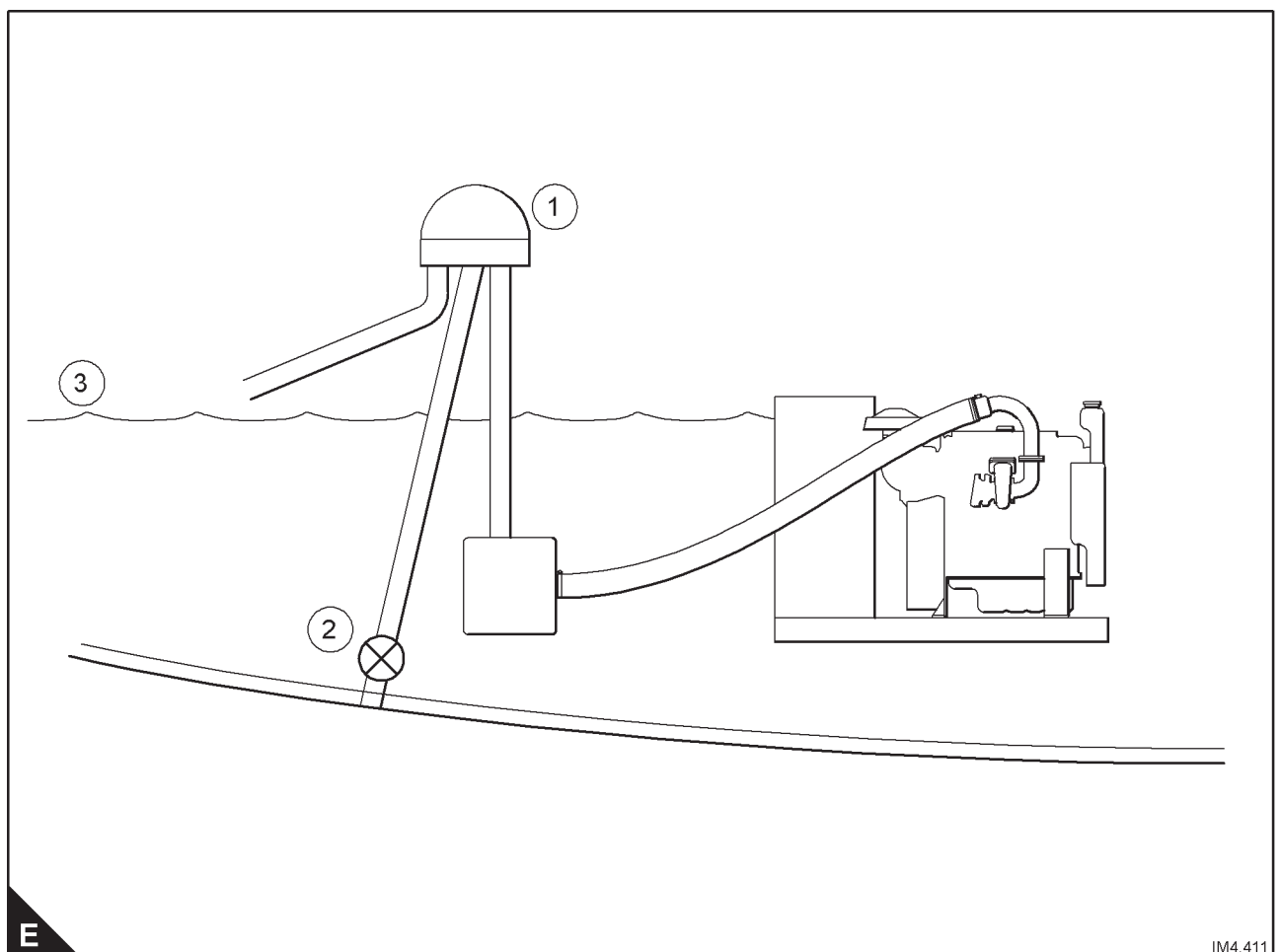

Dry systems

Dry exhaust systems are most commonly used with engines which are keel cooled and are used for environmental reasons in some areas. This arrangement is particularly useful for commercial or pleasure craft operating in heavily silted water with debris and with radiator cooled engines.

Dry exhaust systems for marine installations need careful design to minimise the disadvantages of enclosing components that are at a high temperature in confined spaces. A typical system is shown in (F).

The first part of a dry system should include flexible connections (F2) to permit movement between the engine and the fixed part of the exhaust except the 415GM and 422GM which have a simple flange (F1) for the customer to connect to. Connections of the stainless steel bellows type are suitable, but care must be taken to ensure that they are only required to accommodate movements that do not involve twisting the ends of the bellows relative to each other. Fitting a second bellows (F4) 90 degrees to the first will achieve this. The bellows and elbows should be covered with fire blankets (F3).

The remainder of the exhaust system should be well insulated to avoid fire risk.

If there is a long exhaust run which gains height as it leaves the exhaust manifold, it may be necessary to incorporate a trap to collect condensate and allow it to be drained.

Minimum bore of the exhaust pipe	
415GM	40mm (1.6ins)
422GM	
422TGM	
700GM	
4GM	60mm (2.4ins)
4TGM	
4.4GM & Rad.	
4.4TGM & Rad.	
4.4TWGM & Rad.	76mm (3ins)
4.4TW2GM & Rad.	
6TG2AM	
6TWGM	

Bellows should be in an unstrained condition when installed, so that the full bellows movement is available to absorb expansion and engine movement.

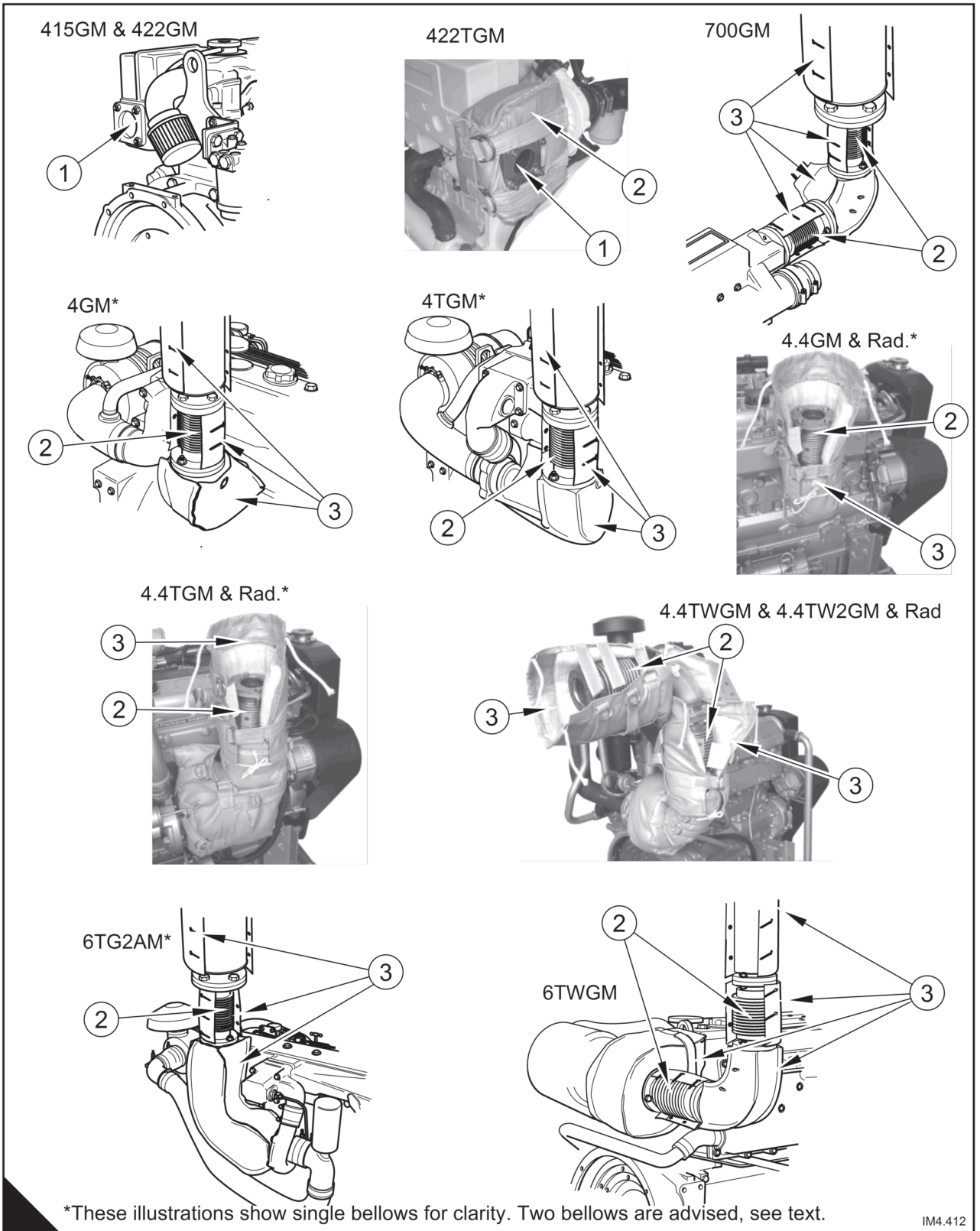

The weight of the exhaust system should be supported by brackets and not carried by the bellows, as shown in (G).

1. Bracket with link to allow movement due to expansion in the exhaust system (horizontal exhaust systems should be suspended from the deck head using similar brackets).

Note: Rigid brackets should not be used

2. Insulating lagging
3. Rigid bracket to support the weight of the vertical exhaust system
4. Heat blanket
5. Twin stainless steel bellows fitted to avoid torsional load on bellows unit - it is strongly recommended that twin bellows are used.
6. Turbocharger adaptor (except 415GM, 422GM, 700GM, 4GM, & 4.4GM)
7. 90° elbow

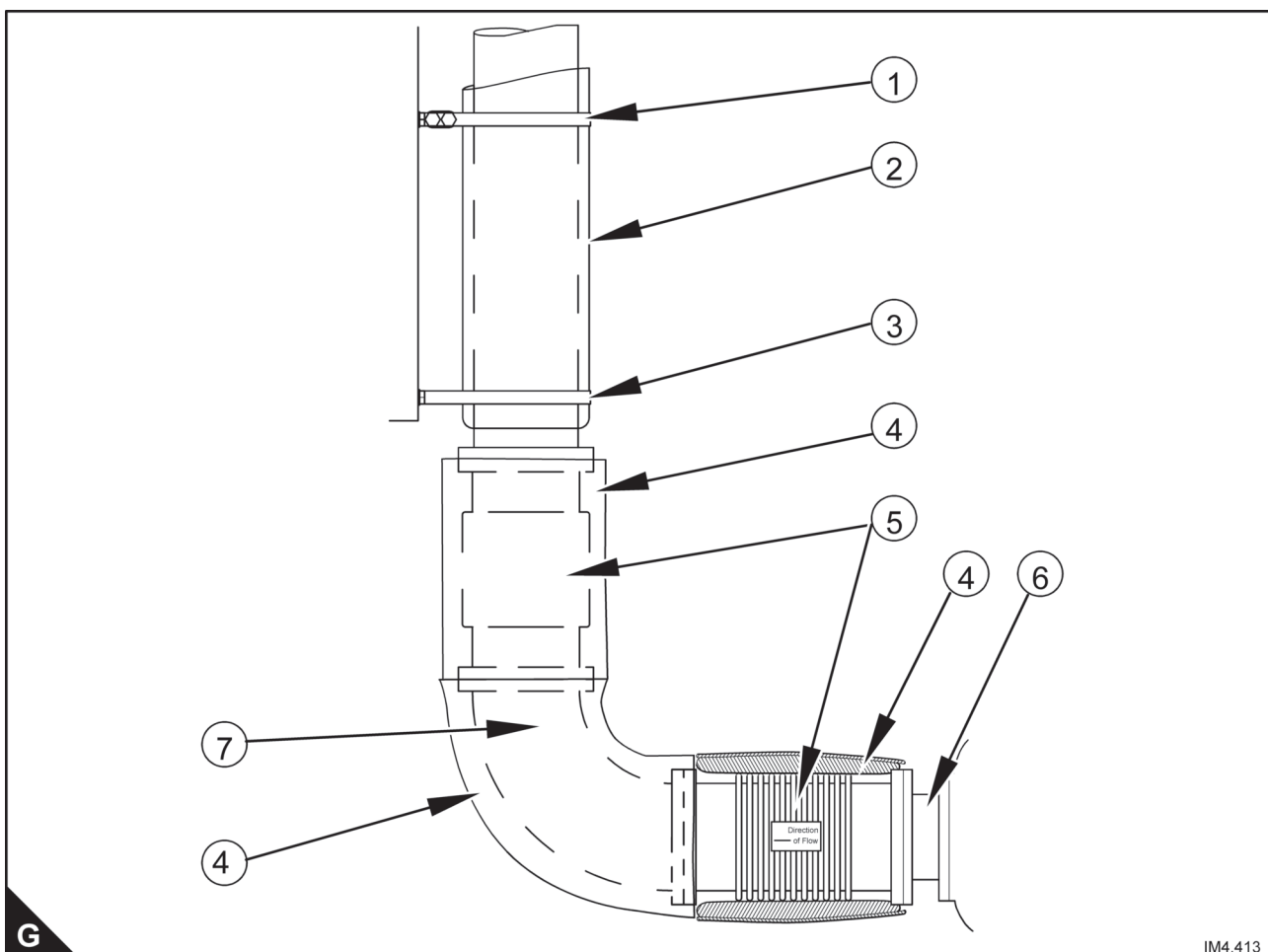
**G**

IM4.413

Fuel systems

Fuel connections

A common reason for service problems with fuel systems is the use of poor or incompatible connectors, where the pressure tightness depends upon the use of sealing compounds, hose clamps, fibre washers trapped between inadequate and unmachined faces, or compression fittings which have been over-tightened to the point where they no longer seal.

Cleanliness during initial assembly is also of vital importance, particularly when fuel tanks are installed, as glass fibres and other rubbish may enter tanks through uncovered apertures.

It is strongly recommended that the flexible fuel pipes available as an option with the engine are used, which are as follows:

Fuel connections - 415GM, 422GM, 422TGM & 700GM

Standard Fuel Feed

The free end of the flexible fuel pipe has either:

- 1/4" BSP male thread.

Standard Fuel Return

The free end of the flexible pipe has either:

- a 1/4" BSP male thread.

Optional Fuel Feed

The free end of the flexible fuel pipe has either:

- 1/4" BSP male thread.

Optional Fuel Return

The free end of the flexible pipe has either:

- a 1/4" BSP male thread.

Caution: Ensure that flexible fuel hose routing avoids coming into contact with parts of the engine which can lead to abrasion of the hose.

Fuel connections - 4GM, 4TGM 4.4GM, 4.4TGM, 4.4TWGM, 4.4TW2GM, 6TG2AM 6TWGM & Radiator Versions

Standard Fuel Feed

- 5/16" OD, nut and olive to suit 5/16" OD steel or copper tube.

Standard Fuel Return

- a 1/4" OD, nut and olive to suit 1/4" OD steel or copper tube.

Optional Fuel Feed

- 5/16" BSP male thread, nut and olive to suit 5/16" OD steel or copper tube.

Optional Fuel Return

- a 1/4" BSP male thread, nut and olive to suit 1/4" OD steel or copper tube.

Caution: Ensure that flexible fuel hose routing avoids coming into contact with parts of the engine which can lead to abrasion of the hose.

Fuel tank connections

The more simple the fuel system, the better it will perform in service.

Fuel tanks should have the following features as shown in (A):

- The filler neck should be raised so that water will not enter when filling.
- The filler cap should seal effectively to prevent water entering when under way.
- A vent pipe should be fitted, again in such a way as to avoid the entry of water.
- The tank (A1) should have a sump or angled bottom with a drain tap (A5) so that water and sediment can be removed. (This is not always possible).
- Stop cocks can be fitted where necessary (A6).
- Internal baffles may be required to prevent fuel surge.
- The tank should have a removable panel to simplify cleaning.
- The fuel pipework should be as simple as possible with the minimum of valves and cross connections, so that obscure fuel feed problems are minimised.
- A fuel sedimenter (water separator) (A2) is required in the fuel system between the fuel tank and the engine mounted lift pump. To avoid problems when venting air after draining the sedimenter, it should preferably be installed below the normal minimum level of fuel in the fuel tank. (This is not always possible!).
- The tank should have at least two connections; a fuel feed connection, (A3) and a fuel return connection (A4). Whenever possible a tank should only supply one engine, but in any case each engine should have its own fuel pipes, from tank to engine.

Typical fuel systems

The more simple the fuel system, the better it will perform in service. Figure (A) shows an ideal system.

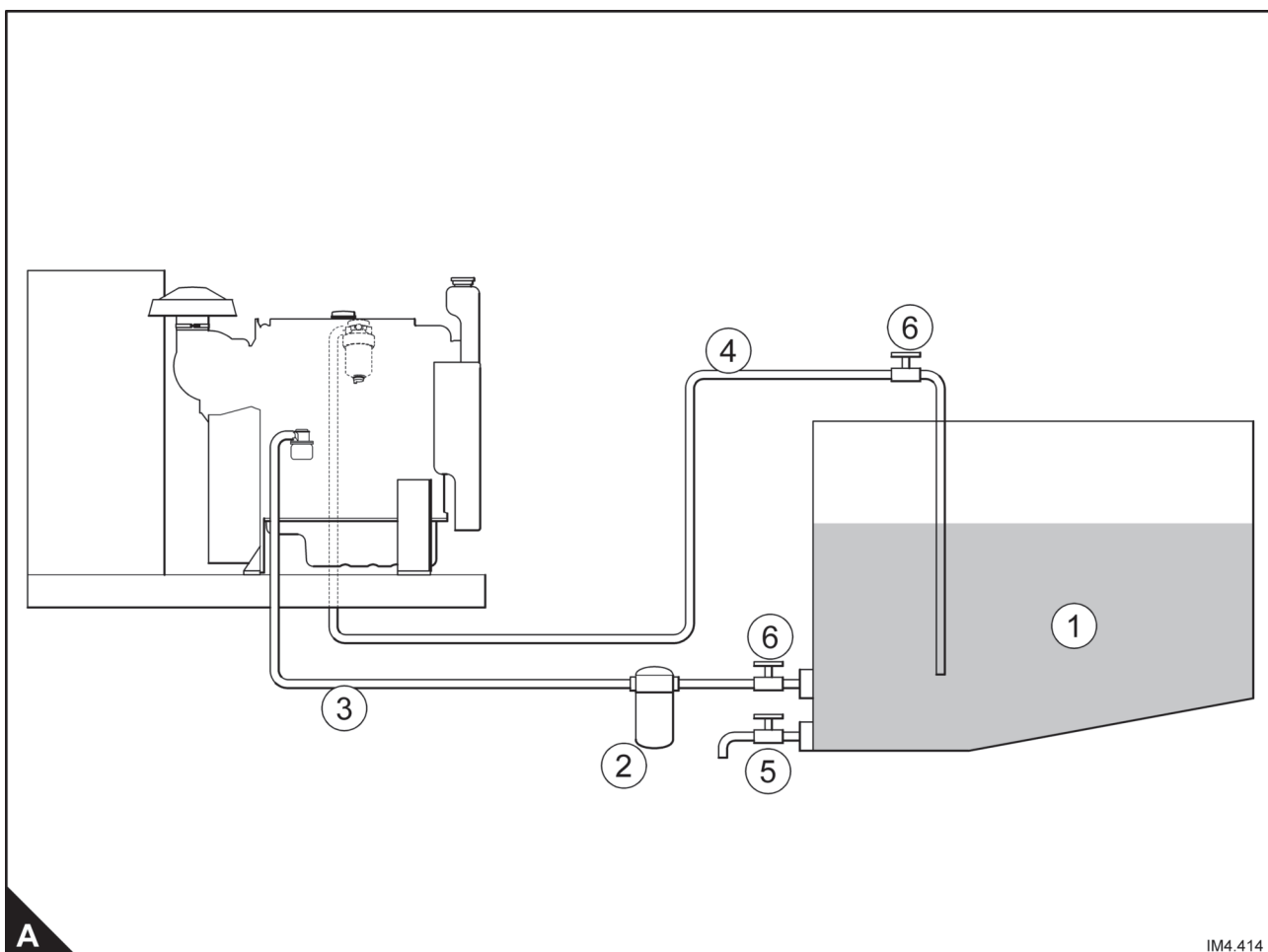

In some applications there may be legislation that requires that fuel lines draw from, and return to, the top of the tank. Figure (B) shows an acceptable arrangement.

- The fuel tank may be steel, aluminium, or G.R.P. (Glass Reinforced Plastic) or, alternatively, a rubber bag tank may be used.
- The main fuel connection is taken from the rear of the tank (B1) so that all the fuel is available for use when under way when the hull will be at an angle.
- The fuel return (B4) is extended within the tank to near the bottom in order to prevent air locks which can arise due to syphoning of the fuel when the engines are stopped
- The fuel returned to the tank should be kept away from the main fuel feed, to avoid recirculation.
- A drain tube (B5) should be fitted to aid servicing and cleaning.
- From the tank the main engine feed line (B2) goes first to a water separator (B3), preferably one fitted with a thick clear plastic bottom and a drain cock (use only if allowed by local regulations).
- The fuel lines may be of metal, either copper or seamless steel tubing used either with compression fittings or preferably soldered nipples, with a flexible armoured rubber hose to connect to the fuel lift pump.
- Stop cocks (B6) may also be fitted where necessary.

This simple fuel system is satisfactory when one or more engines are run from a single fuel tank, and it may also be used when there are two tanks each supplying one engine. In the latter case the system may include a cross connection, between the tanks by means of a balancing pipe, with a valve, at each end. In some installations cross connecting pipes between the two engine feed pipes and the two engine return pipes have been used, but valves are necessary in every line so that the appropriate system may be selected, and the complexity of installation and operation is such that the advantages in operating flexibility are out-weighted by the possibility of obscure problems due to component malfunctions, incorrect operation or engine interaction.

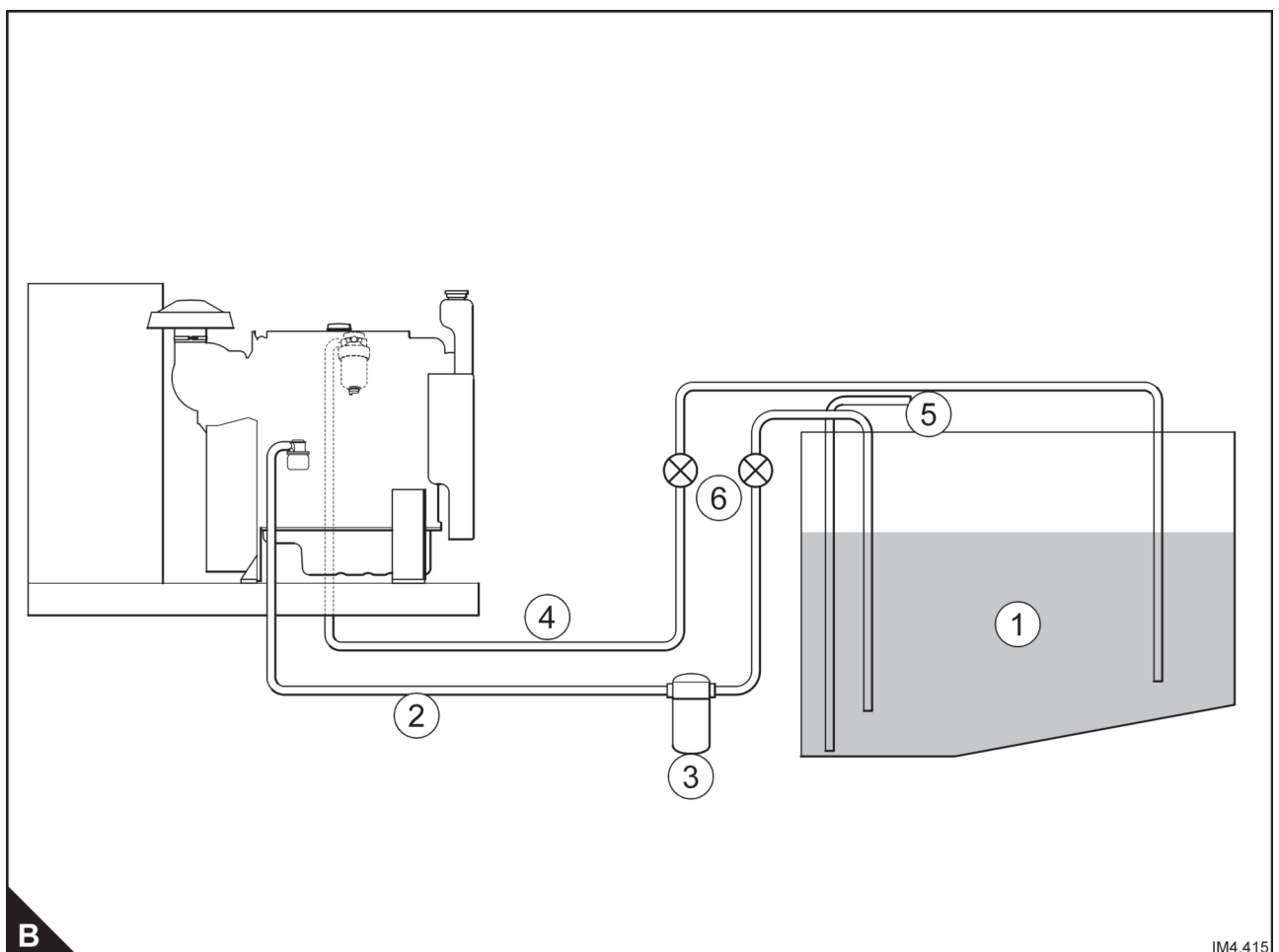

In some cases it is necessary to have a number of fuel tanks in order to achieve the required operating range. In such cases, where possible, one tank should be regarded as the main tank for each engine and the other tanks should be arranged so that they will drain into the main tank by gravity. If a gravity system is not possible, then the system shown in figure (C) should be used.

Figure (C) shows a collector tank (C1), fed by all the storage tanks (C2) and connected to the engine feed and return systems, but with a vent pipe (C3) taken to any convenient tank and connected to it at the highest point. The fuel feeds (C5) should be taken from the bottom of the collector tank and the fuel returns (C6) at the top.

A water separator (C4) should be installed which should suit the total flow for all the installed engines.

There is no doubt however, that a simple fuel system as illustrated in Figure (A) or (B) should be used wherever possible, as having a completely separate tank and supply to each engine guarantees that if an engine stops, due to running out of fuel or to water or foreign matter in the fuel, the other engine will not be affected simultaneously. This will give some time for appropriate manoeuvring action to be taken. The simple system will also require the minimum number of valves and fittings, which ensures maximum reliability in service.

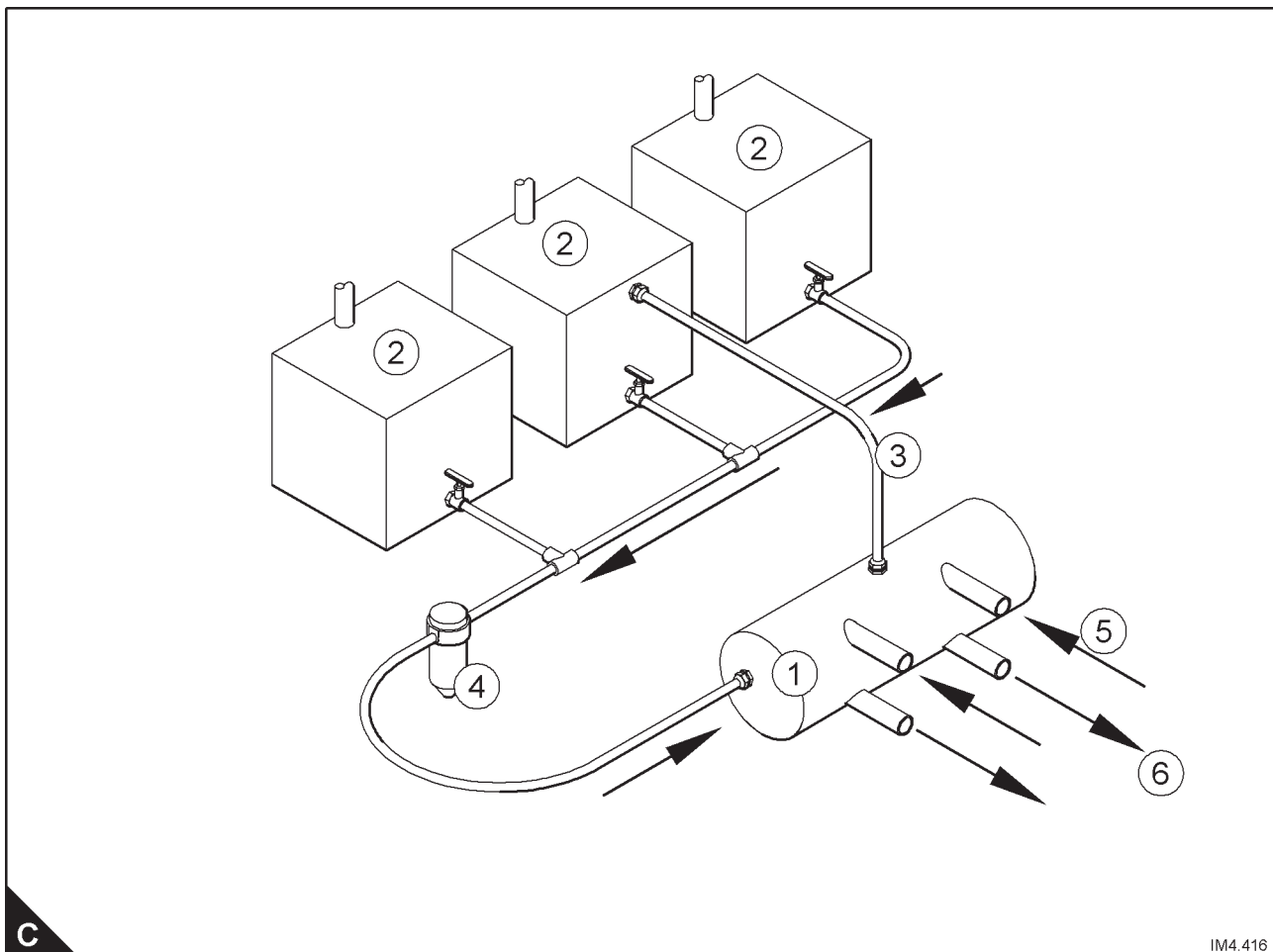

IM4.416

Raw water systems

A completely separate sea water system should be provided for each engine to prevent a blockage resulting in the need to shut down more than one engine.

A typical system is shown in figure (A).

The water intake fitting (A6), situated below the water line (A1), should not project appreciably below the bottom of the hull and it should be situated well clear of other components such as shafts, logs, rudders to prevent flow problems at high speeds.

The intake fittings and pipework should have a minimum bore of 25mm (1") (A2). Inboard of the intake fitting a 1 inch BSP or NPT sea cock (A3) must be provided. This should be of the full flow type giving unobstructed passage to the water in the open position, with a minimum bore of 25mm (1").

Between the intake fitting and the sea water pump (A4) on the engine, there should be a strainer (A5) which should be easily accessible for routine examination, and should be easily removable.

Note: Ensure a separate feed for each engine. A shared supply is not recommended.

From the sea water strainer a pipe should be run to the sea water pump inlet connection on the engine (see figure A). The pipe may either be mainly rigid, of for example copper or cupro-nickel, or flexible, but only flexible hose which is reinforced to prevent collapse should be used. The system must be sufficiently flexible to permit the engine to move on its flexible mountings. The sea water pump connection is for hose with a 32mm (1.25") bore.

Care should be taken to use compatible materials in the sea water systems, to prevent excessive galvanic corrosion. Systems incorporating copper, cupro-nickel, stainless steel Type 316, gun-metal, silver solder, and aluminium brass will generally be satisfactory. Components made from lead, iron, steel, aluminium or its alloys, zinc or magnesium, should be generally avoided.

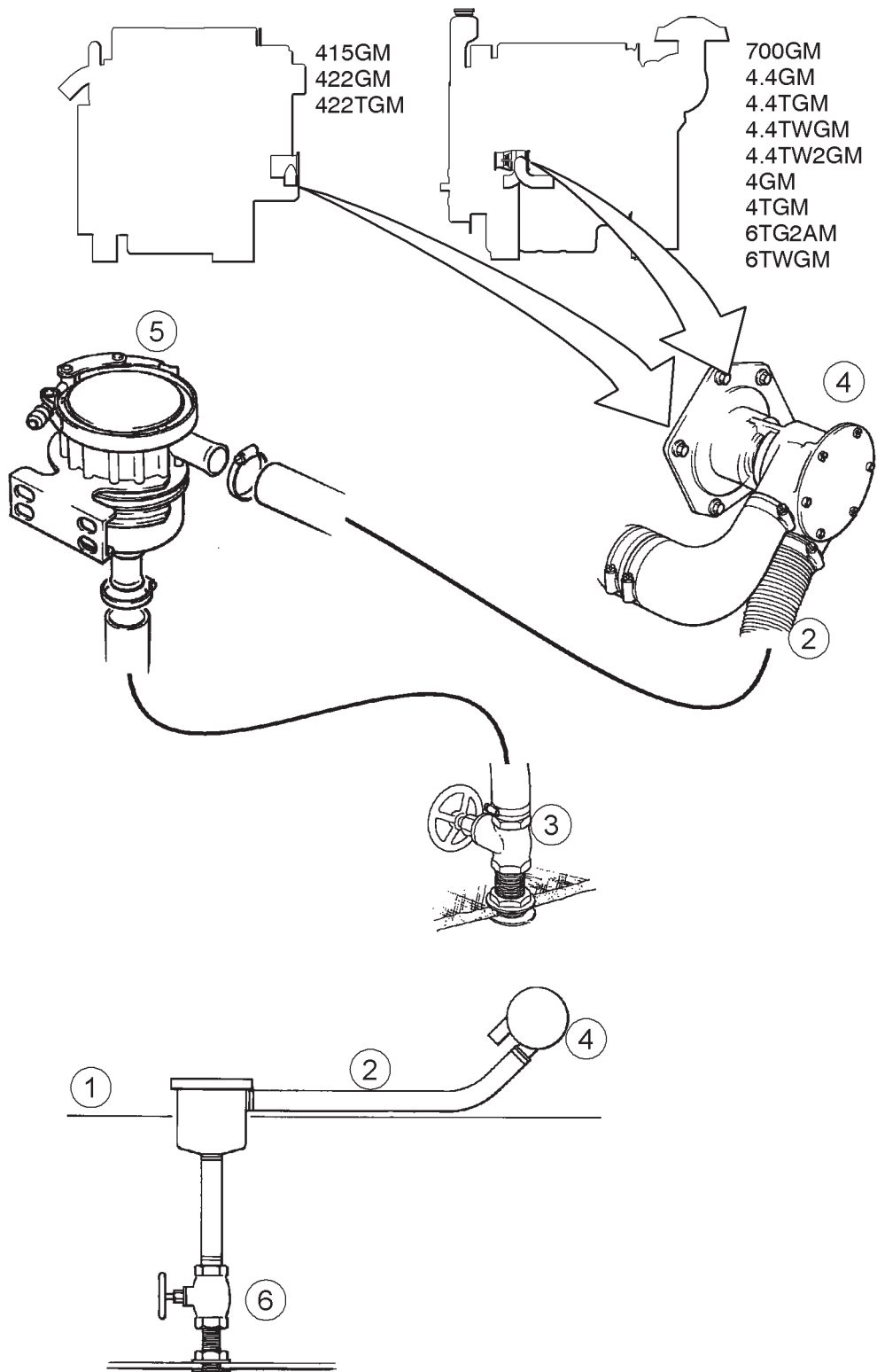

A

IM4.417

Note: Where possible mount the strainer so that the top is just above the waterline to facilitate cleaning.

Keel cooling or skin cooling

Keel cooling or skin cooling is a closed circuit method of cooling that uses only coolant with 50/50 antifreeze mix.

A properly designed and installed cooling system is essential for satisfactory engine life and performance.

This system uses a group of tubes, pipes or channels attached to the outside of the hull below the waterline as a heat exchanger. Keel coolers are used in preference to the standard raw water cooled engine mounted heat exchanger when operating in areas that have heavy silt and debris in the water that would erode the heat exchanger tubes or block them.

Keel cooling is used in Arctic conditions to avoid the problems of freezing that is experienced with the raw water circuit on the heat exchanger cooling system.

Keel coolers are available in standard designs from several manufacturers. These units are simple to install and are sized by the manufacturer for the engine model and boat application. Commercial coolers are made of erosion resistant materials and have a relatively high heat transfer efficiency.

The disadvantage of external keel coolers is that they are vulnerable to damage and must be guarded. An alternative to the commercially available coolers are fabricated keel coolers manufactured by the boat builder as part of the hull construction. These coolers are not as efficient and must be designed oversize to allow for a decrease in performance that follows the formation of rust, scale and marine growth on the keel cooler.

If the genset is a replacement package and the original cooling system, keel cooler and expansion tank, is to be reused, then it is essential that the system thoroughly flushed to remove sludge that may be in the system. Failure to remove sludge could block air bleeds leading to the engine overheating.

Sizing the coolers

Commercial keel coolers are manufactured in a variety of sizes and shapes. The keel cooler manufacturer will recommend a keel cooler when provided with the following data:-

- Engine model and rating
- Engine data sheet, see section 7
- Heat Rejection (see table below)
- Engine coolant flow rates are at a system resistance of 28kPa (4 lbf/in²)
- Max. coolant temperatures from grid cooler
- Maximum raw water temperature
- Pipe connections - see illustrations on following pages.
- Coolant - 50/50 antifreeze mix

Warning! Twin grid coolers are required for the 4.4TWGM, 4.4TW2GM and 6TWGM

Heat rejection data						
Engine model	415GM	422GM	422TGM	700GM	4GM	4TGM
Heat rejection						
Jacket water - Engine Btu/min	1109	1302	2098	-	2250	3424
kW	19.5	22.9	36.9	TBA	39.5	60.2
Aftercooler - Intercooler Btu/min	-	-	-	-	-	-
kW	-	-	-	-	-	-
Water flow rate, thermostat fully open						
Engine US gals/min	12.9	13.7	13.7		25.6	25.6
Litres/min	49	52	52	TBA	97	97
Intercooler US gals/min	-	-	-	-	-	-
Litres/min	-	-	-	-	-	-
Max coolant temp						
(from grid cooler)				140	140	140
Engine °F				60	60	60
°C				-	-	-
Intercooler °F				-	-	-
°C						

Heat rejection data (cont.)						
Engine model	4.4GM	4.4TGM	4.4TWGM	4.4TW2GM	6TG2AM	6TWGM
Heat rejection						
Jacket water - Engine Btu/min	2440	2838	3338	4172	5198	6541
kW	42.9	49.9	58.7	73.3	91.4	115
Aftercooler - Intercooler Btu/min	-	-	774	956	-	1570
kW	-	-	13.6	16.8	-	27.6
Water flow rate, thermostat fully open						
Engine US gals/min	39.6	39.6	39.6	39.6	22-40	20-40
Litres/min	150	150	150	150	77-150	77-150
Intercooler US gals/min	-	-	27	27	-	20
Litres/min	-	-	102	102	-	91
Max coolant temp						
(from grid cooler)						
Engine °F	140	140	140	140	140	140
°C	60	60	60	60	60	60
Intercooler °F	-	-	100	100	-	100
°C	-	-	38	38	-	38

As a general rule the pressure drop across the grid cooler should be between 14 - 28kPa (2 to 4 psi) this can be achieved by keeping the water velocity below 0.46m/s (5ft/s).

The above table shows data that will satisfy all world wide operational conditions. However, if the application is known to be only operating in areas where the sea water temperature is unlikely to exceed 25°C, then when sizing the grid coolers the maximum coolant temperature returning to the intercooler of 43°C could be used and 75°C coolant temperatures returning to the engine circuit.

Keel cooling connections- 415GM, 422GM & 422TGM

Figure (B) shows the connections

Connections are both 32mm (1.25 inches).

- 1. Connections
- 2. Flow
- 3. Keel cooler
- 4. Engine

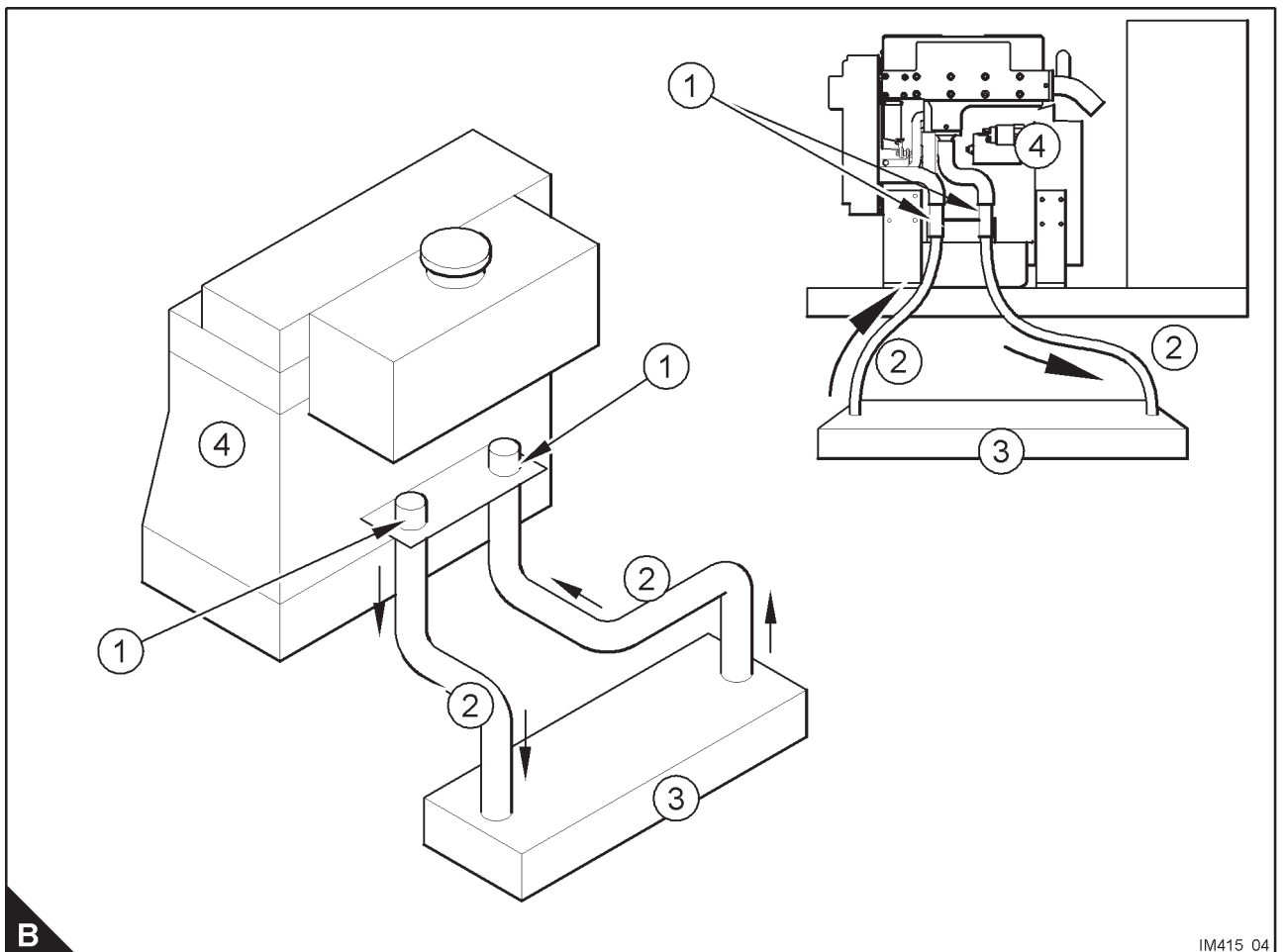

IM415_04

Keel cooling connections - 700GM

Figure (C) shows the connections and flow.

Connections sizes are both 38mm (1.5 inches).

1. Connections
2. Flow
3. Keel cooler
4. Combined header tank and exhaust manifold
5. Thermostat
6. Engine
7. Fresh water pump
8. By pass

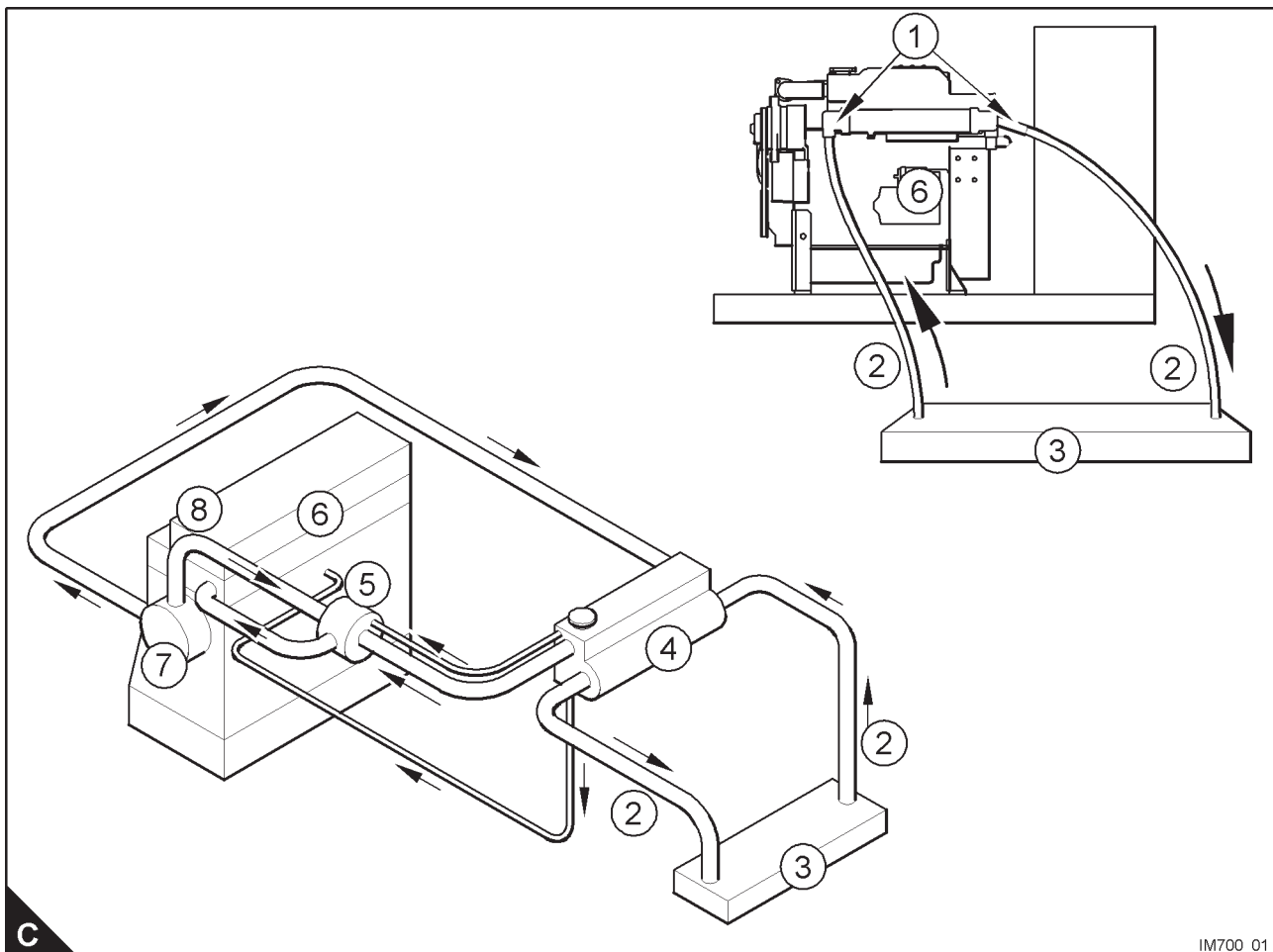
**C**

IM700_01

Keel cooling connections - 4GM and 4TGM

Figure (D) shows the connections and flow.

Connections sizes are both 38mm (1.5 inches).

- 1. Connections
- 2. Flow
- 3. Keel cooler
- 4. Engine oil cooler
- 5. Fresh water pump
- 6. By pass
- 7. Engine
- 8. Thermostat
- 9. Exhaust manifold
- 10. Header tank

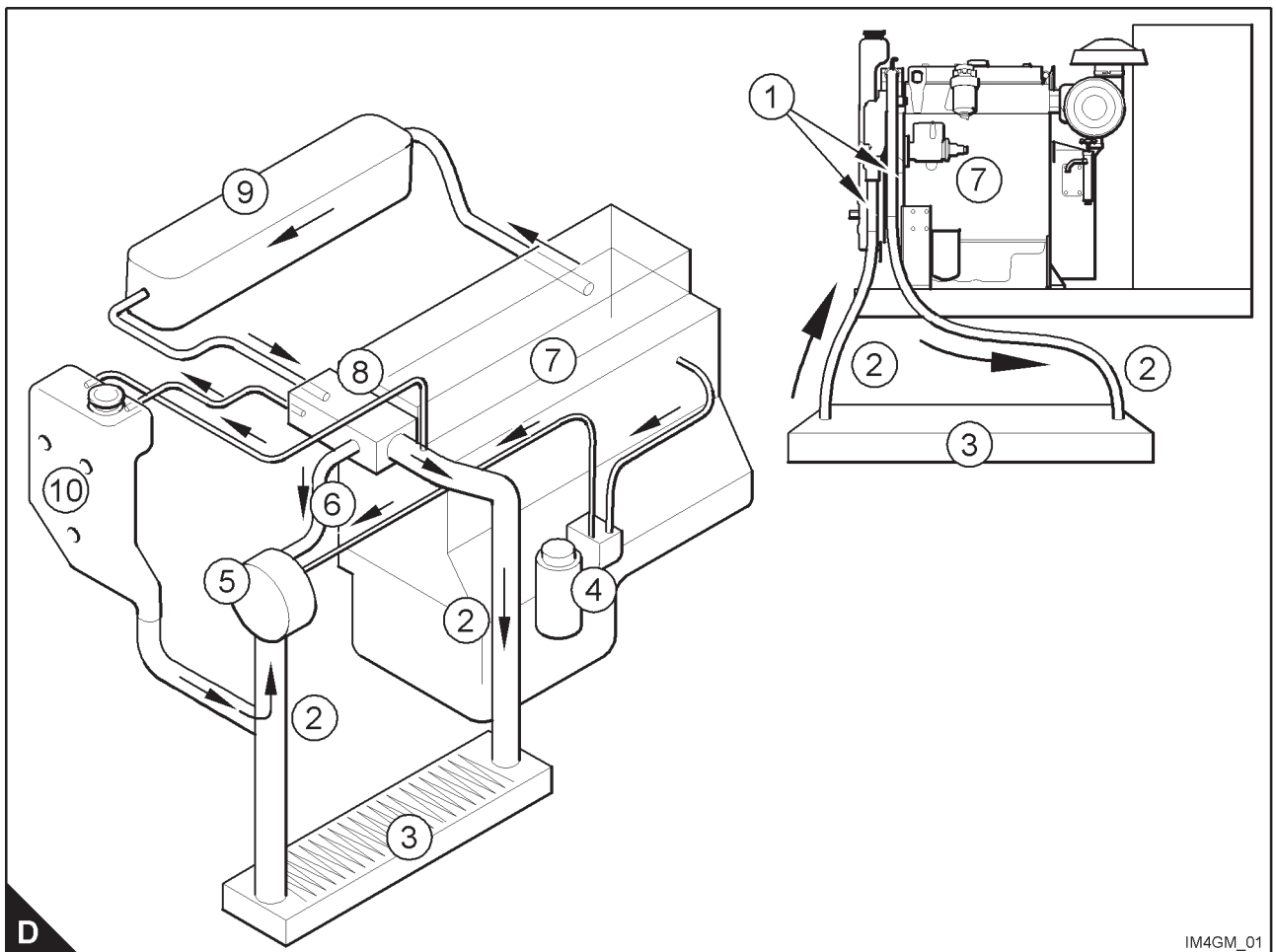

IM4GM_01

Keel cooling connections - 4.4GM and 4.4TGM

These engines do not have a header tank as part of the engine package, but have a remotely mounted expansion tank.

Figure (E) shows the connections and flow.

Connections sizes are both 38mm (1.5 inches).

1. Connections
2. Flow
3. Keel cooler
4. Remote tank
5. Fresh water pump
6. Thermostat
7. Engine
8. Integral engine oil cooler
9. Exhaust manifold

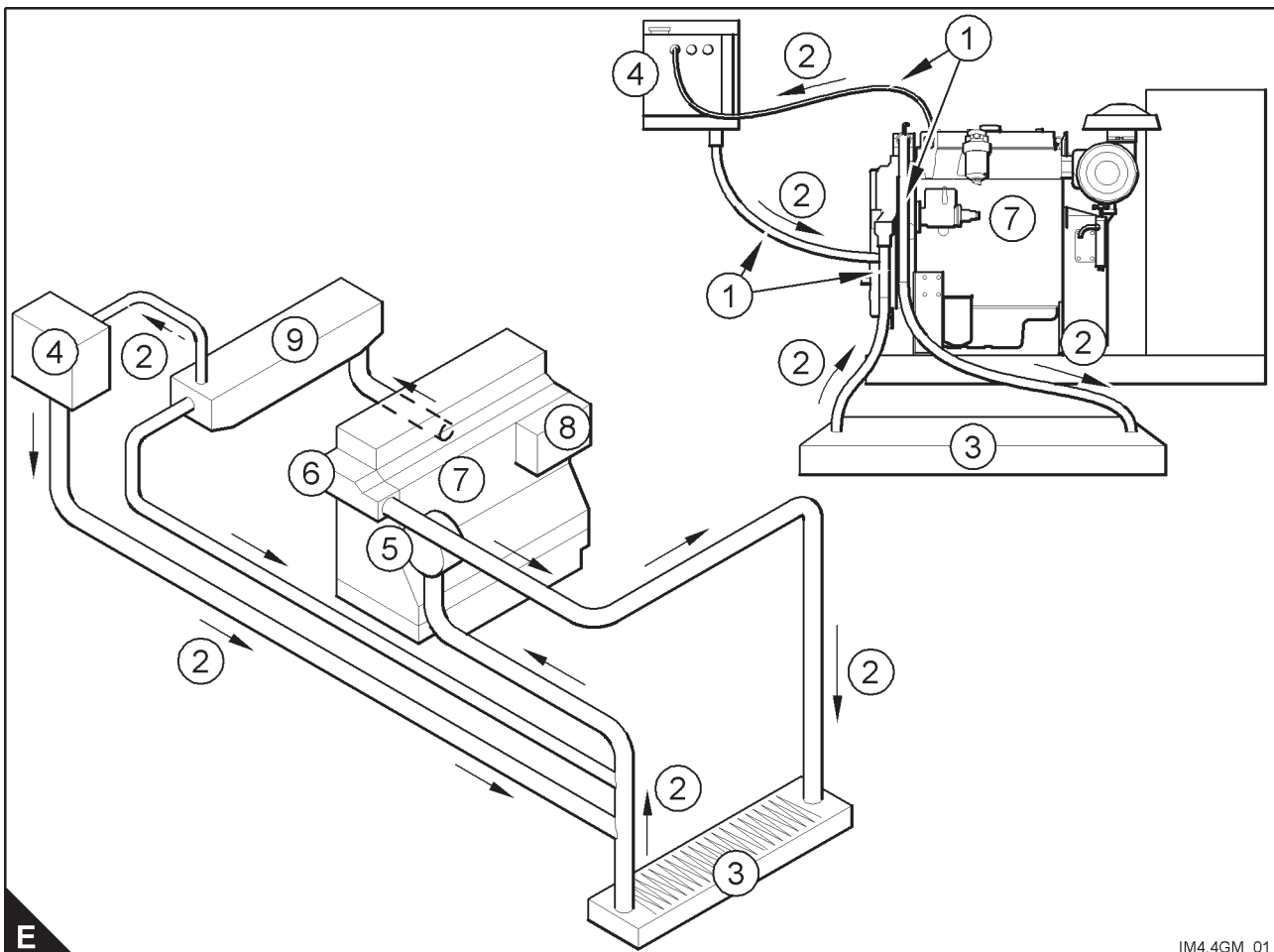

E

IM4.4GM_01

Keel cooling connections - 4.4TWGM and 4.4TW2GM

These engines require two keel coolers and do not have a header tank as part of the engine package, but have a remotely mounted expansion tank. Figure (F) shows the connections and flow. Connections sizes are 38mm (1.5 ins) for the water jacket circuit and 32mm (1.25 ins) for the aftercooler circuit.

- | | | |
|----------------|-------------------------------|---------------------|
| 1. Connections | 5. Fresh water pump | 9. Exhaust manifold |
| 2. Flow | 6. Thermostat | 10. Aftercooler |
| 3. Keel cooler | 7. Engine | 11. Bleed |
| 4. Remote tank | 8. Integral engine oil cooler | 12. Raw water pump |

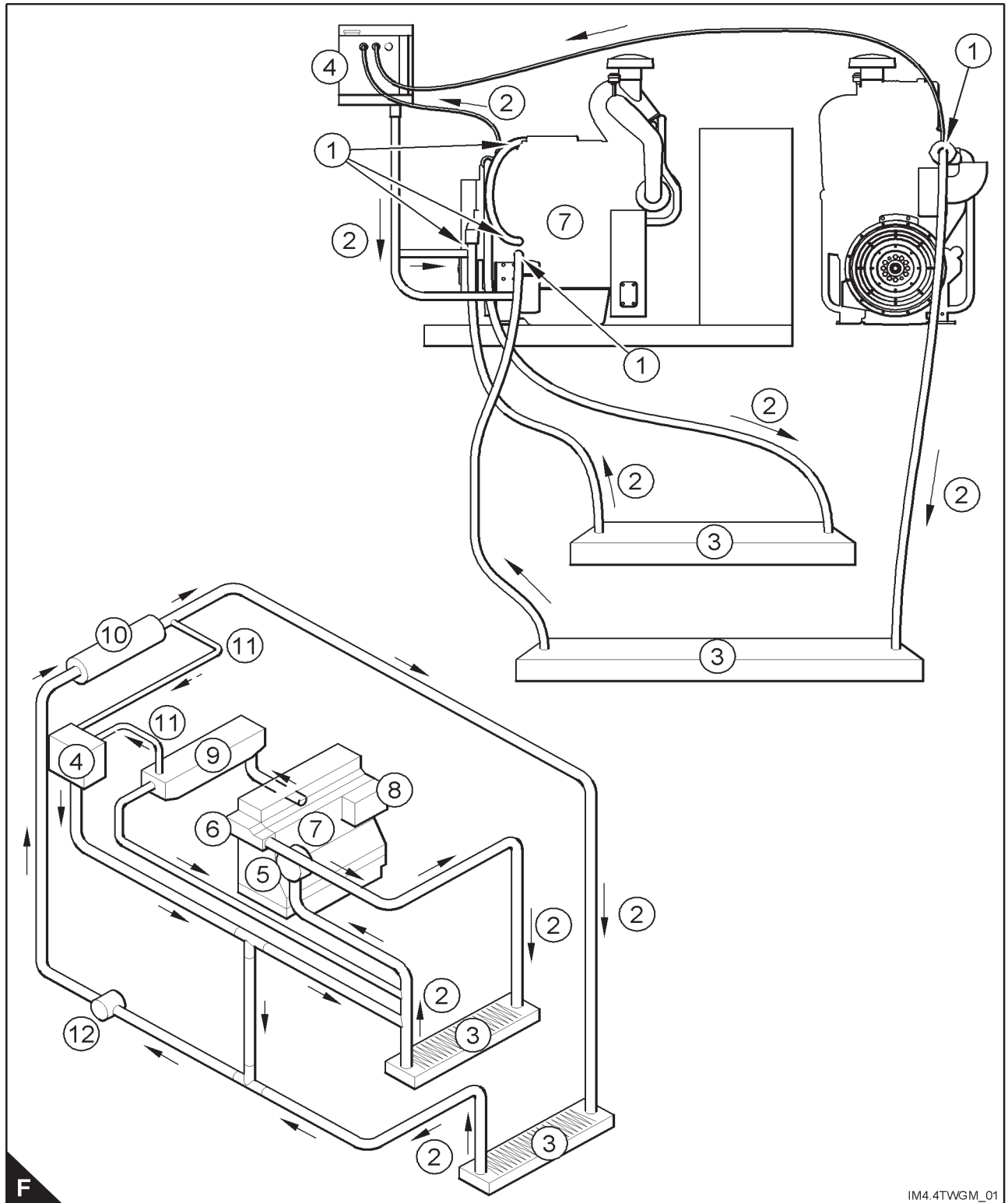

F

IM4.4TWGM_01

Keel cooling connections - 6TG2AM

Figure (G) shows the connections and flow.

Connections sizes are both 45mm (1.75 inches).

1. Connections
2. Flow
3. Keel cooler
4. Thermostat
5. Bleed pipe
6. Engine oil filter
7. Engine oil cooler
8. Fresh water pump
9. Engine
10. High water temperature switch
11. Header tank
12. Exhaust manifold

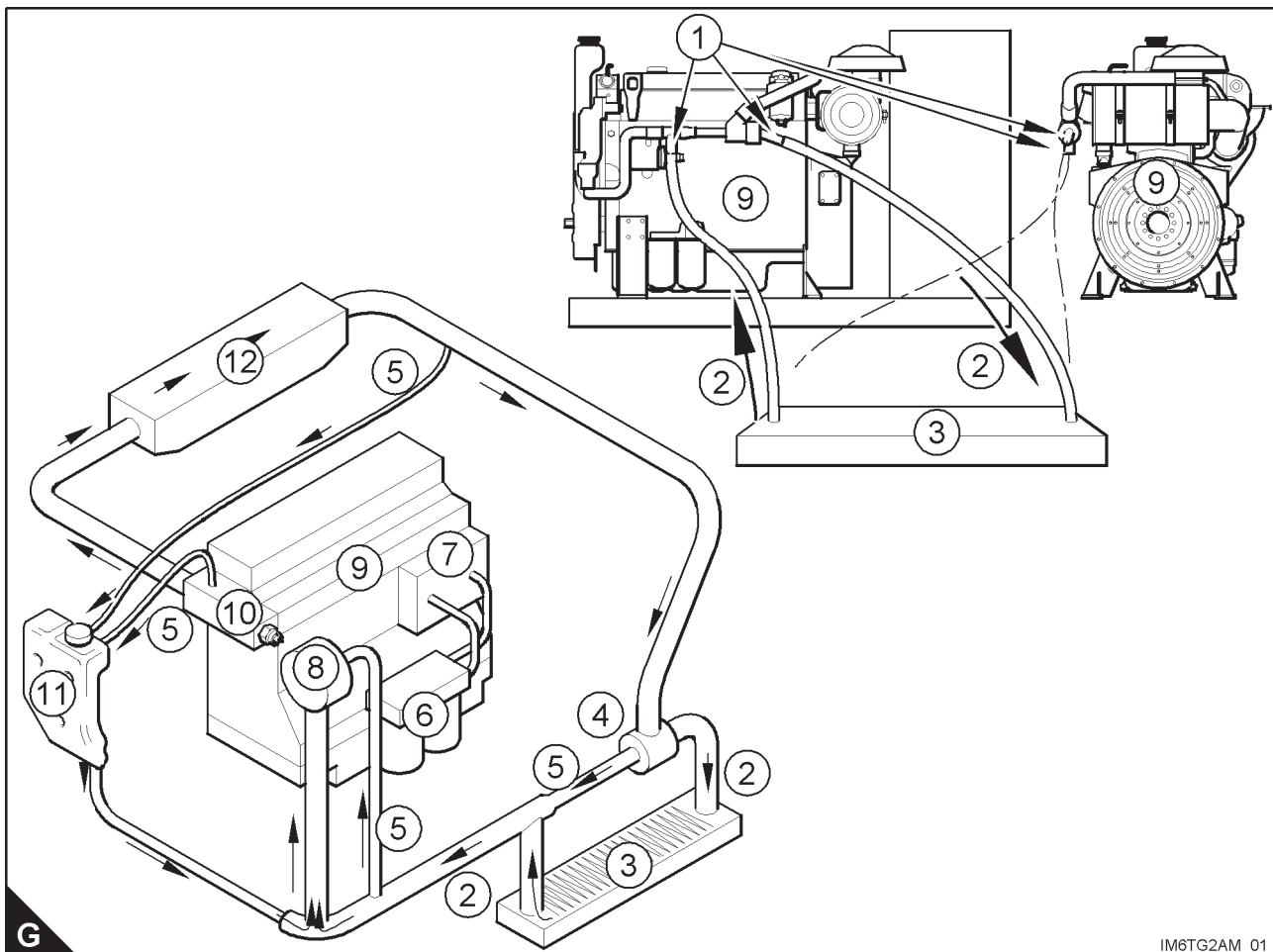

IM6TG2AM_01

Keel cooling connections - 6TGWM

Figure (H) shows the connections and flow. Connections sizes are 44.5mm (1.75 ins) for the water jacket circuit and 32mm (1.25 ins) for the aftercooler circuit.

- | | | |
|----------------|---------------------|----------------------|
| 1. Connections | 5. Thermostat | 9. Header tank |
| 2. Flow | 6. Bleed | 10. Exhaust manifold |
| 3. Keel cooler | 7. Raw water pump | 11. Intercooler |
| 4. Engine | 8. Fresh water pump | |

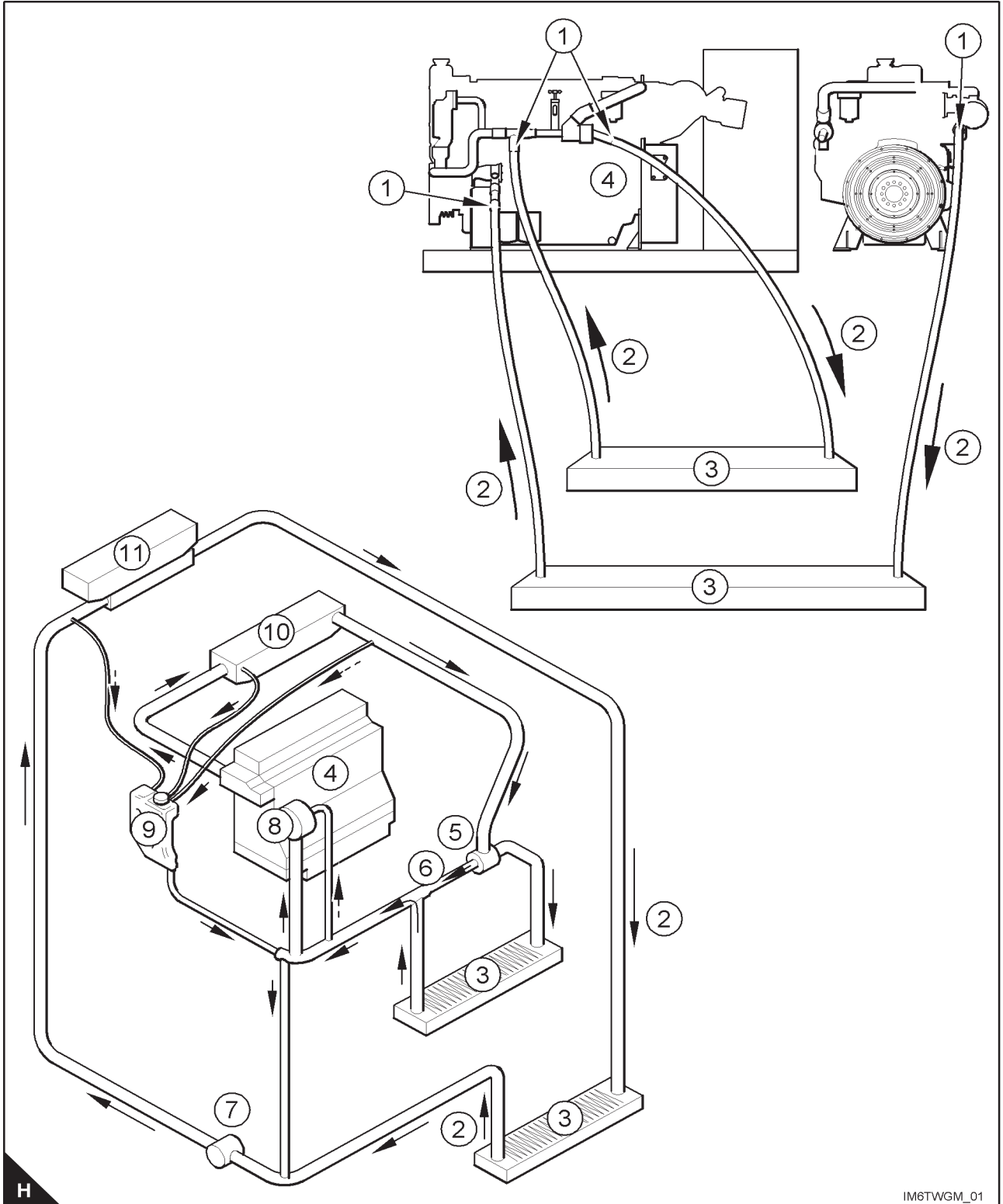

H

IM6TGWM_01

Keel coolers should be installed below the waterline far enough to avoid the aerated water close to the surface. Recessed and shielded coolers must allow for unobstructed flow around the coolers. The keel coolers should be installed so that air pockets are not present during the initial fill. Vents at all high points along the connecting pipes will be necessary.

Keel coolers should not be fitted where they would be exposed to pounding seas or hull flexing. The bow of the vessel is not considered to be a good location whereas adjacent to the keel, where it is the strongest area of the vessel, is the preferred location.

De-aeration

Warning! Air in the engine coolant can cause the following problems:

1. Air accelerates the corrosion within the engine water passages that can lead to high water temperatures as silt deposits on the surface of the cooler reducing the heat transfer. Premature failure of the engine can occur.
2. Air expands more than coolant when heated and may cause loss of coolant from the engine system through the expansion tank overflow.
3. In an extreme case, air will collect in one area and cause a loss of coolant flow around the cylinder block resulting in piston seizure and major engine damage.

Radiator cooled

Radiator cooled engines are typically used for emergency units or if the engine is located more than 4m above the sea water, such as on the deck of barges.

The radiator cores are fully tinned to give the best corrosion protection and are therefore capable of operating in worldwide environments. The design allows for air on temperatures of 50°C at both 1500 and 1800 rev/min, 50% ethylene glycol and 200Pa duct allowance. The air velocity over the radiator is 5m/s for both the NA/turbo and turbo aftercooled engines. A pusher fan is used that has an airflow of 1.8m³/s for the Na/turbo and 2.5m³/s for the aftercooled engines at 1800 rpm.

Expansion Tank

The expansion volume in the tank must be large enough for the entire cooling system. Since the engine coolant expands about 5% between cold and hot engine operating temperatures, the expansion tank must have a volume equal to 5% of the entire cooling system volume.

When designing the larger expansion tank the following allowance should be made:

- A 50 kPa pressure cap should be fitted to pressurise the system.
- 3% to 5% of total system capacity for expansion losses
- 10% of total system capacity for volume loss on hot shut down
- 5% of total system capacity for working volume

The illustration (I) shows the allowances required when designing a larger expansion tank.

Engine bleed (Vents)

Warning! Joining the bleed pipes into a common vent will reduce the total water flow and may result in aerated water flowing back into the engine resulting in the engine overheating and possible failure.

The engine bleed system provides a continuous flow of water through the expansion tank as a method of removing air from the engine coolant. Depending on the model of the engine there can be up to three bleed pipes which need to be connected to the top of the expansion tank. Each bleed must be connected to the expansion tank without using tee's or other fittings that would join the bleed pipes together in a common vent.

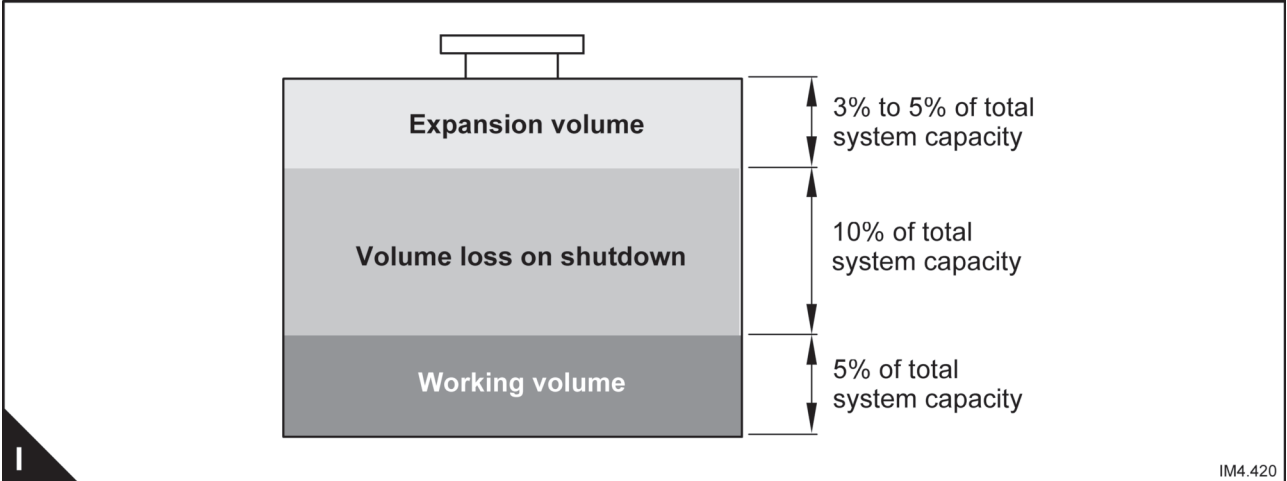

Remote expansion tank - 4.4GM, 4.4TGM & 4.4TW2GM

A remotely mounted expansion tank is supplied as standard with a capacity of 19 litres. A remote cooler expansion tank kit can be fitted using the following procedure.

1. Mount the remote expansion tank in a position where the bottom of the unit is as shown in figure (J).
2. Connect the new bleed hoses (J2) to the tank and the fittings on the engine.
3. Connect the main inlet hose to the engine (J3).

4.4GM & 4.4TGM

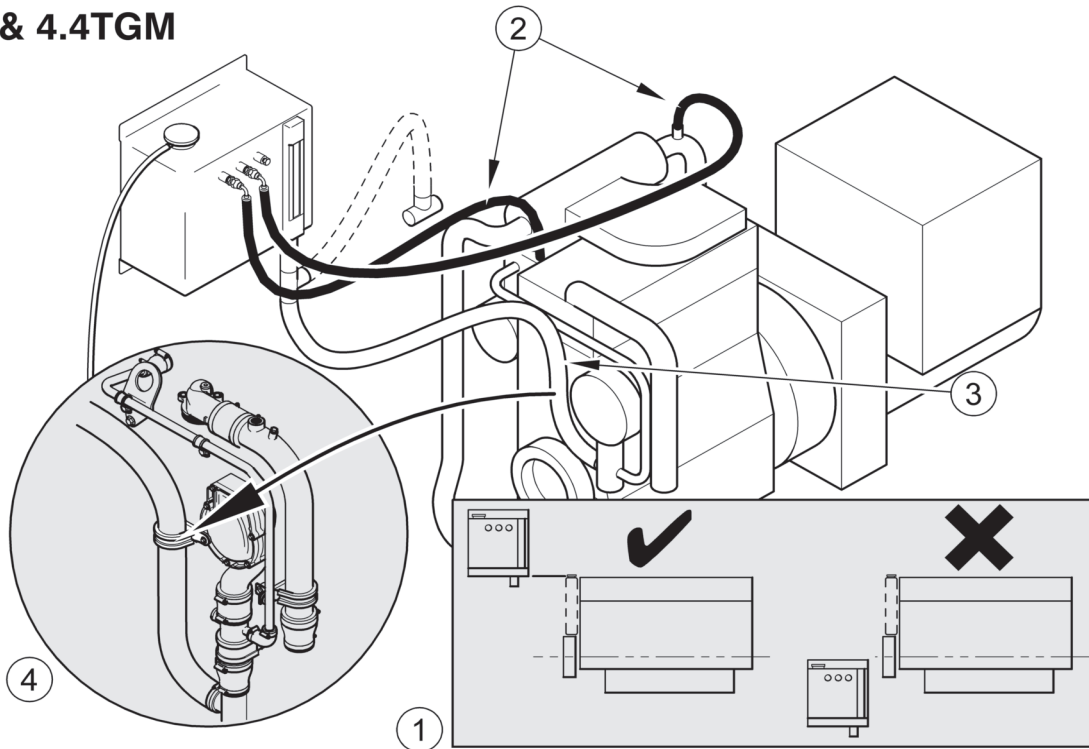

4.4TGM & 4.4TW2GM

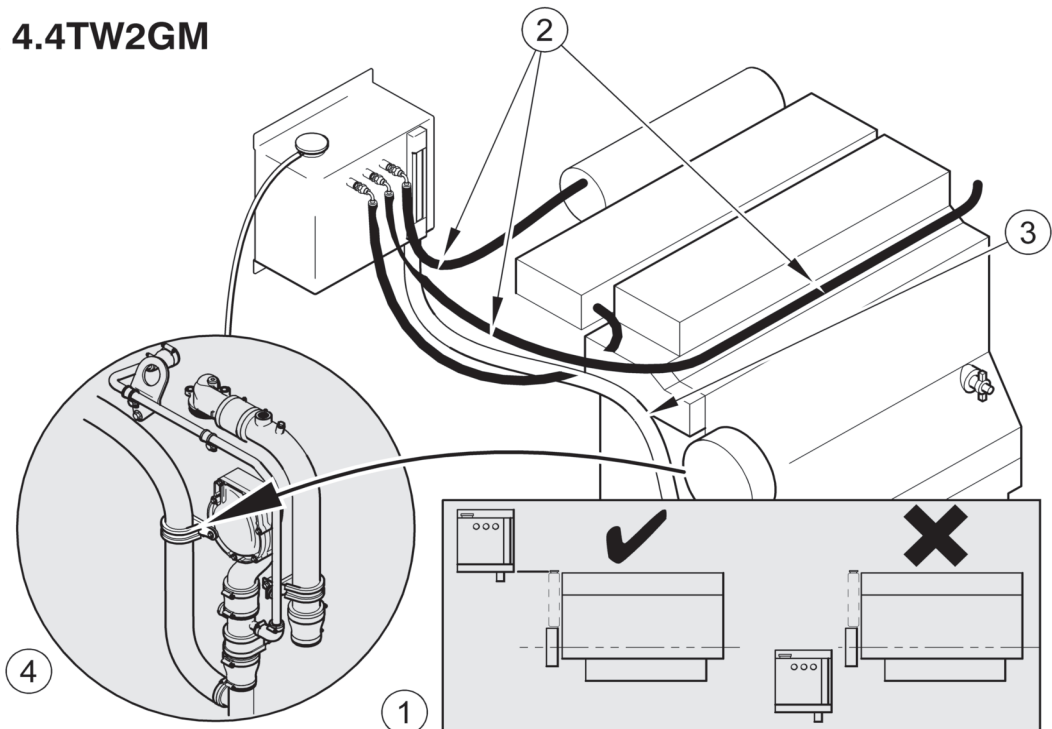

J

IM4.421

4. Secure the inlet hose (J3) the front of the engine in the position shown in (J4) with the hose clip.
5. Fill the remote expansion tank with 50% antifreeze solution (K1) to the maximum position on the sight glass (K2).

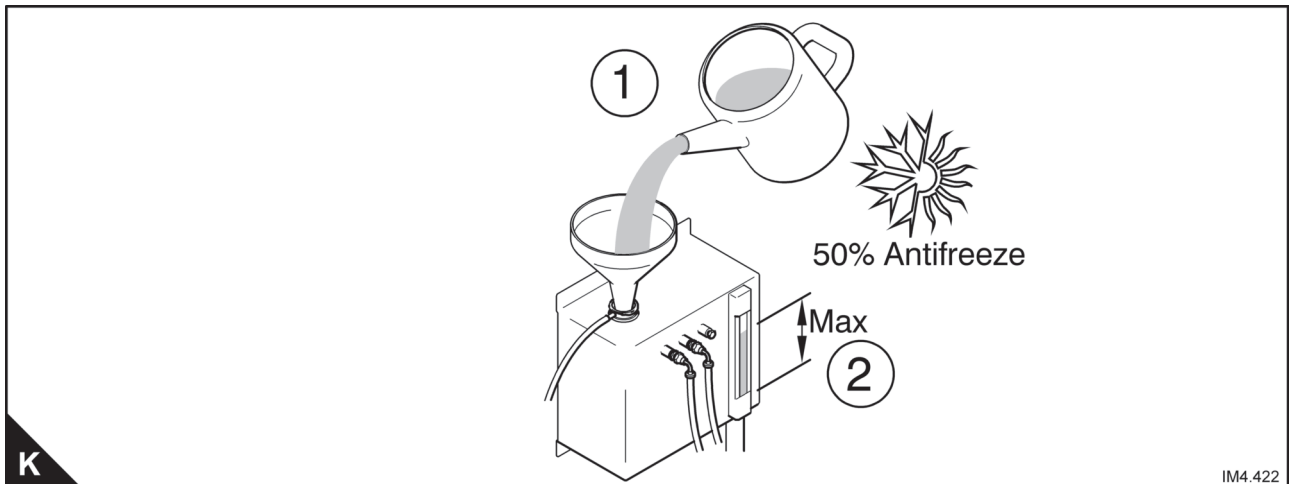

6. Start engine (L1).
7. Run engine until normal working temperature is reached, between 82 to 88oC (L2).
8. Stop engine (L3).
9. Switch off panel (L4).

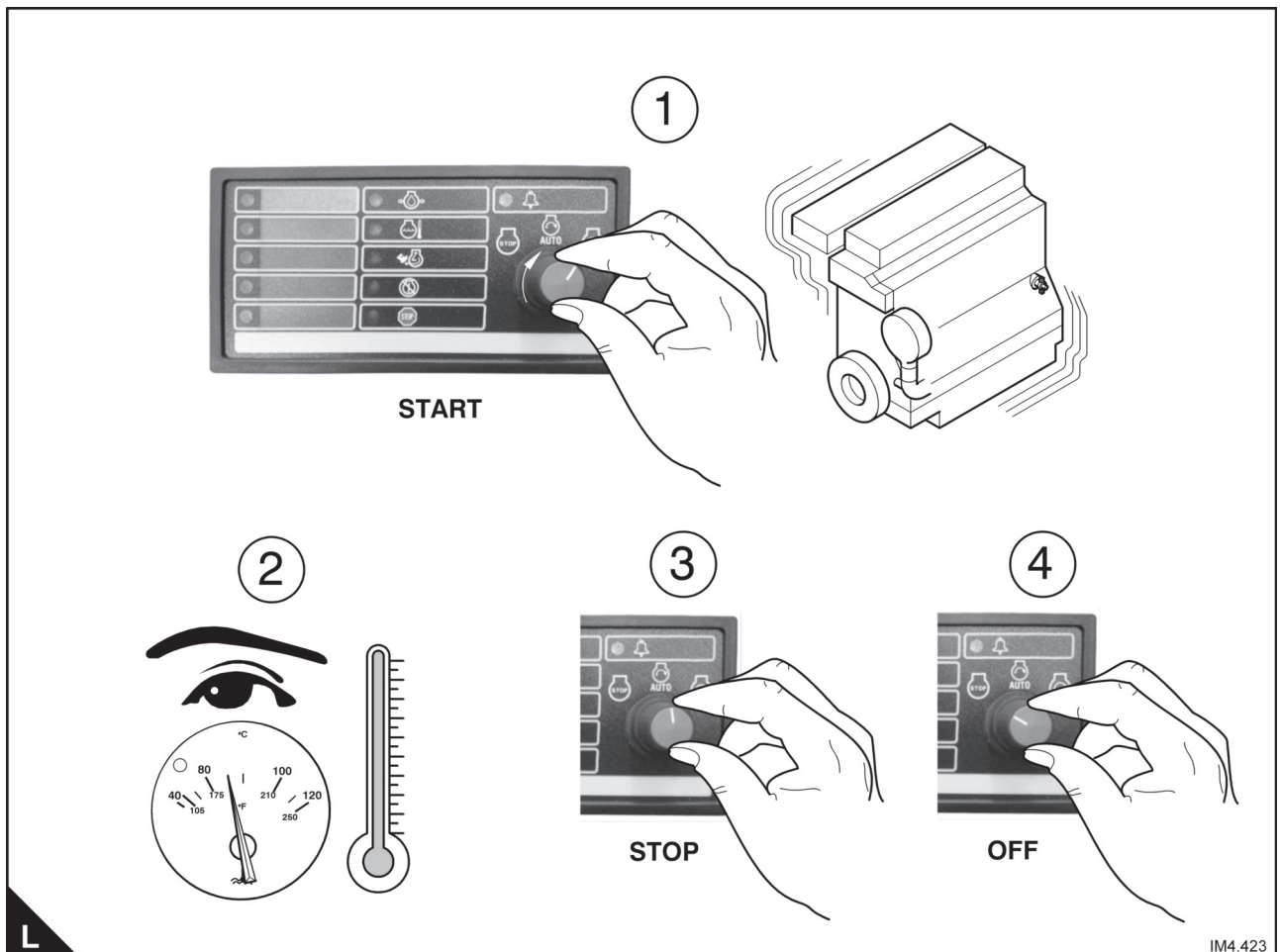

10. Check coolant level in the sight glass (M1)

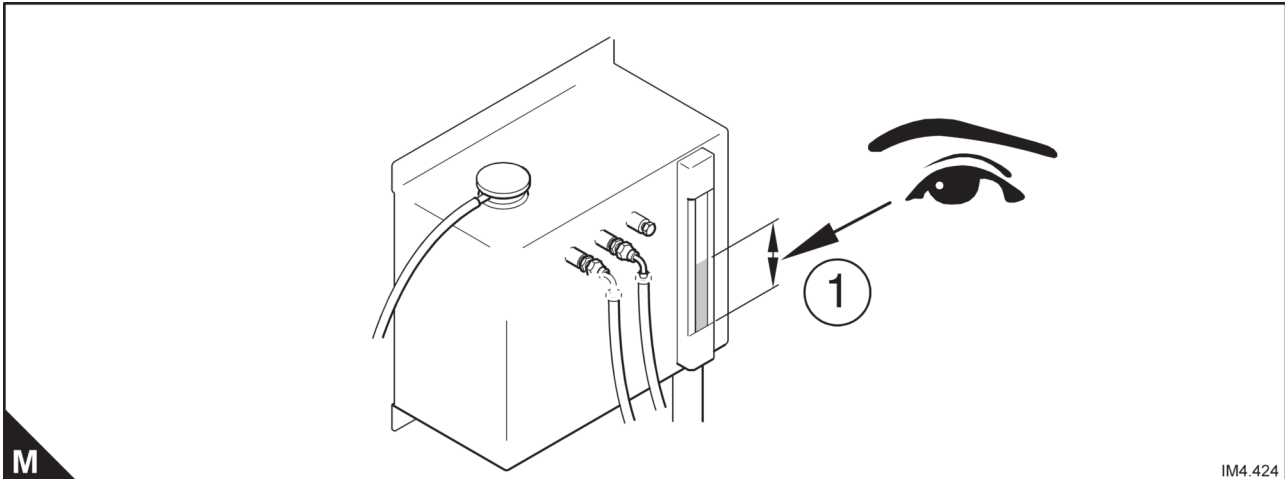

IM4.424

Warning! Hot coolant is under pressure and can cause severe burns when removing the pressure cap. First release the pressure in the system by loosening the pressure cap.

11. Top-up with 50% antifreeze to maximum level (N1).

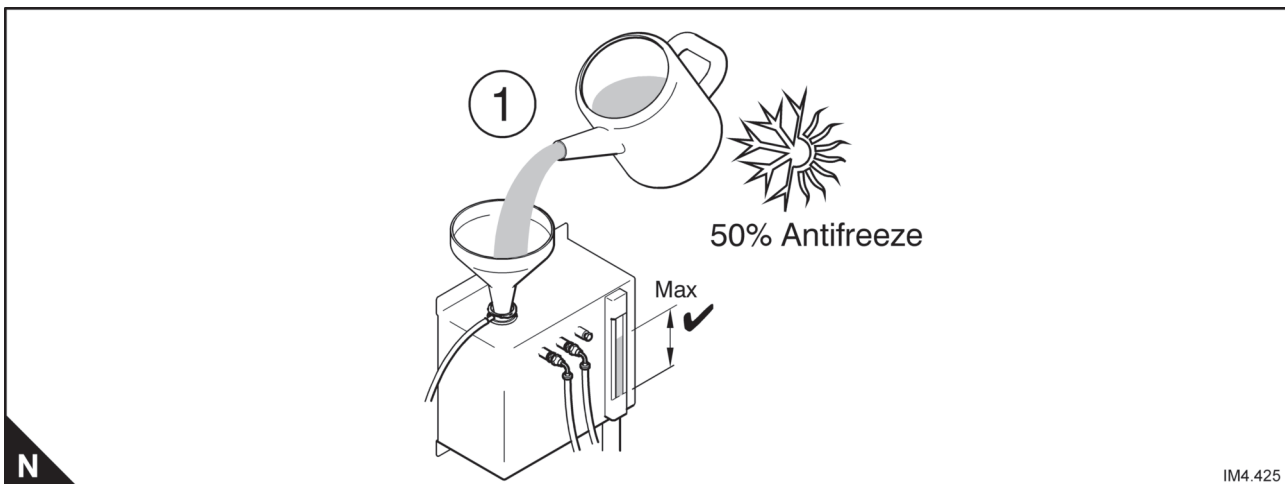

IM4.425

Remote expansion tank - 4GM, 4TGM and 6TG2AM

A remotely mounted expansion tank is recommended where longer pipe runs are required and where fabricated coolers are used. A remote cooler expansion tank kit can be fitted using the following procedure.

1. Figure (O) shows draining the engine coolant (O1), cutting, removing and discarding the bleed pipes (O2), and removing the existing expansion tank (O3) and disposing of the rubber elbow (O4) at the base.

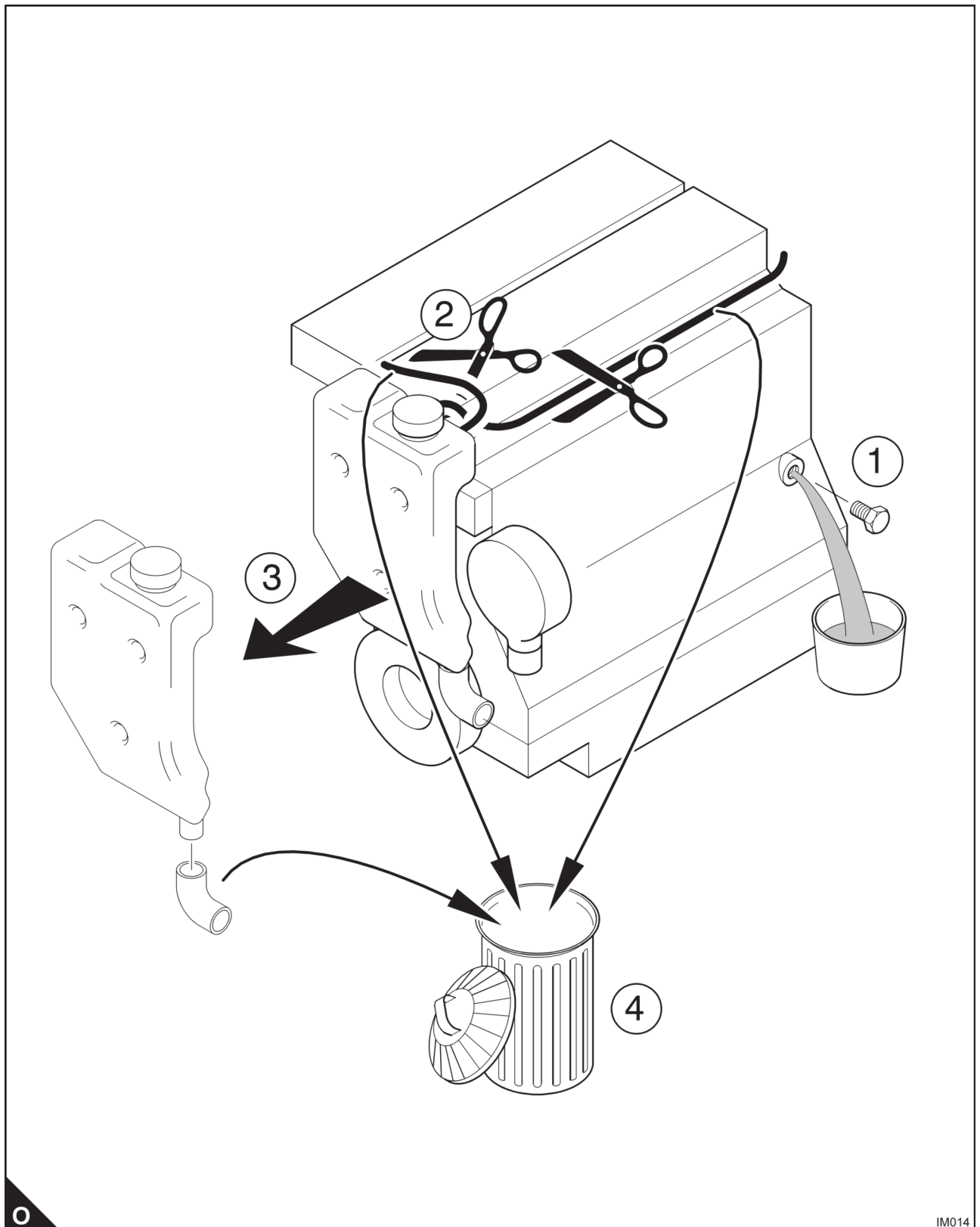

2. Mount the remote expansion tank in a position where the bottom of the unit is no lower than where the filler cap was (P1) on the original expansion tank, as shown in figure (P).
3. Connect the new bleed hoses (P2) to the tank and the original fittings on the engine.
4. Connect the main inlet hose to the engine (P3).
5. Secure the inlet hose (P3) the front of the engine in the position shown in (P4) with the hose clip.

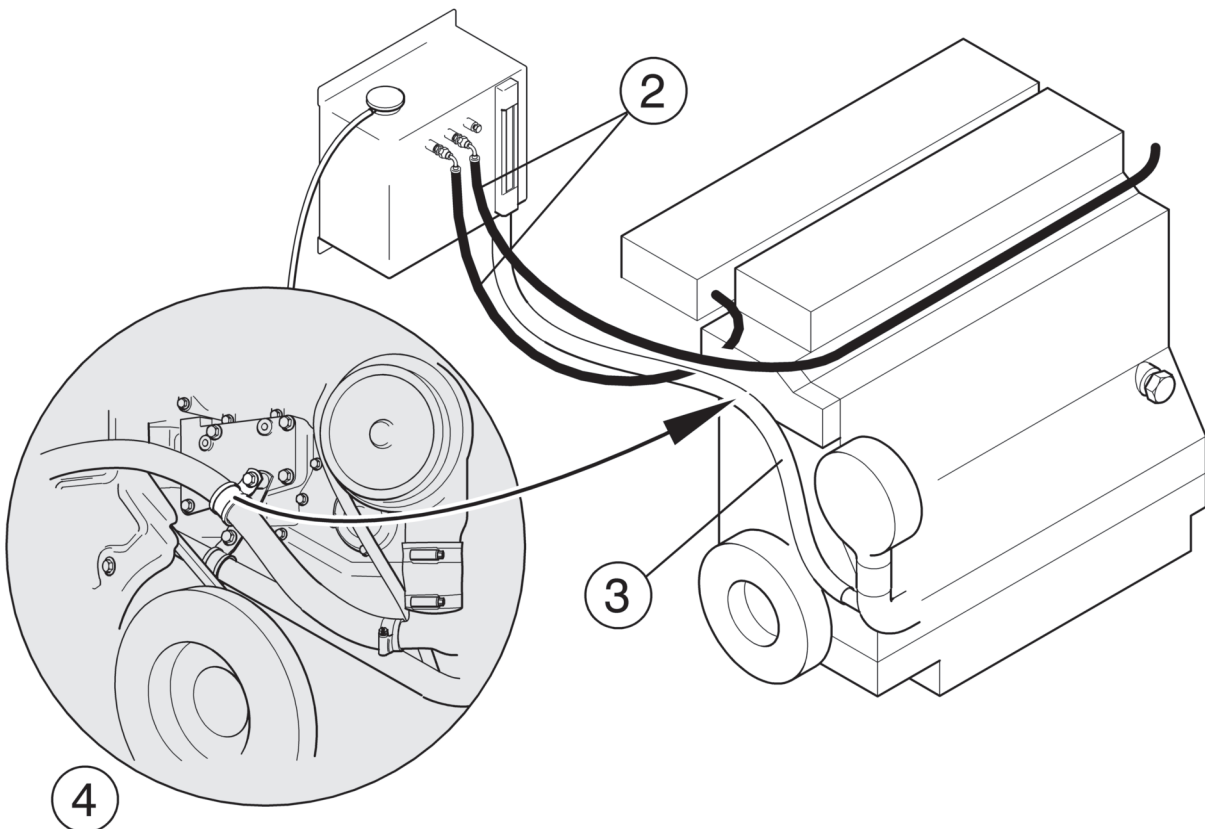
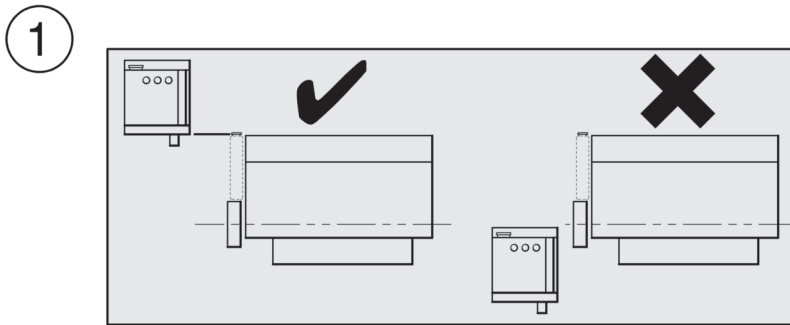

P

IM015

6. Fill the remote expansion tank with 50% antifreeze solution (Q1) to the maximum position on the sight glass (Q2).

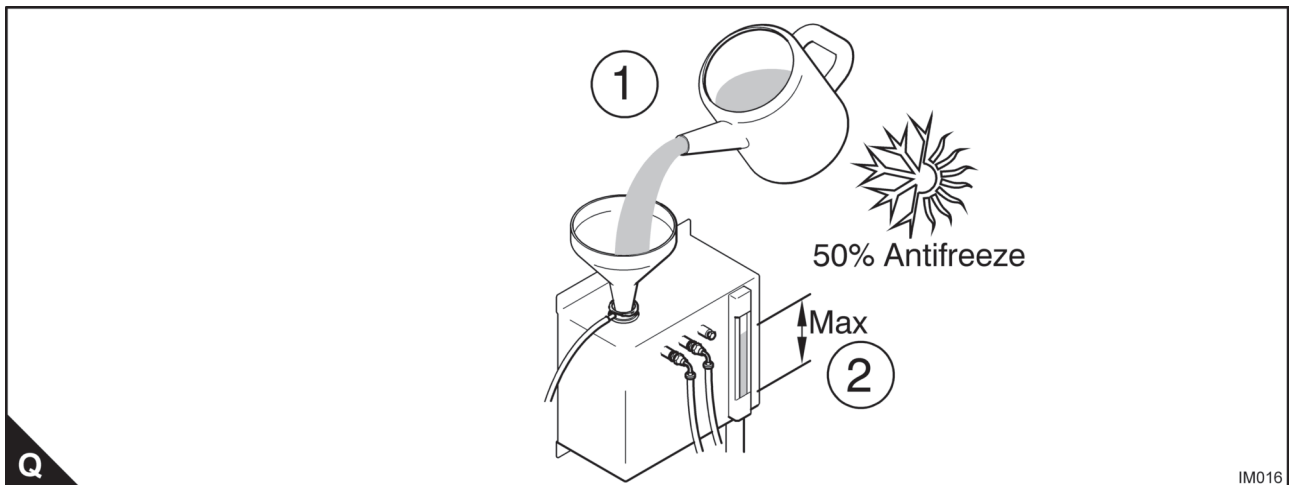

7. Switch on engine panel (R1).
8. Start engine (R2).
9. Run engine until normal working temperature is reached, between 82 to 88oC (R3).
10. Stop engine (R4).
11. Switch off panel (R5).

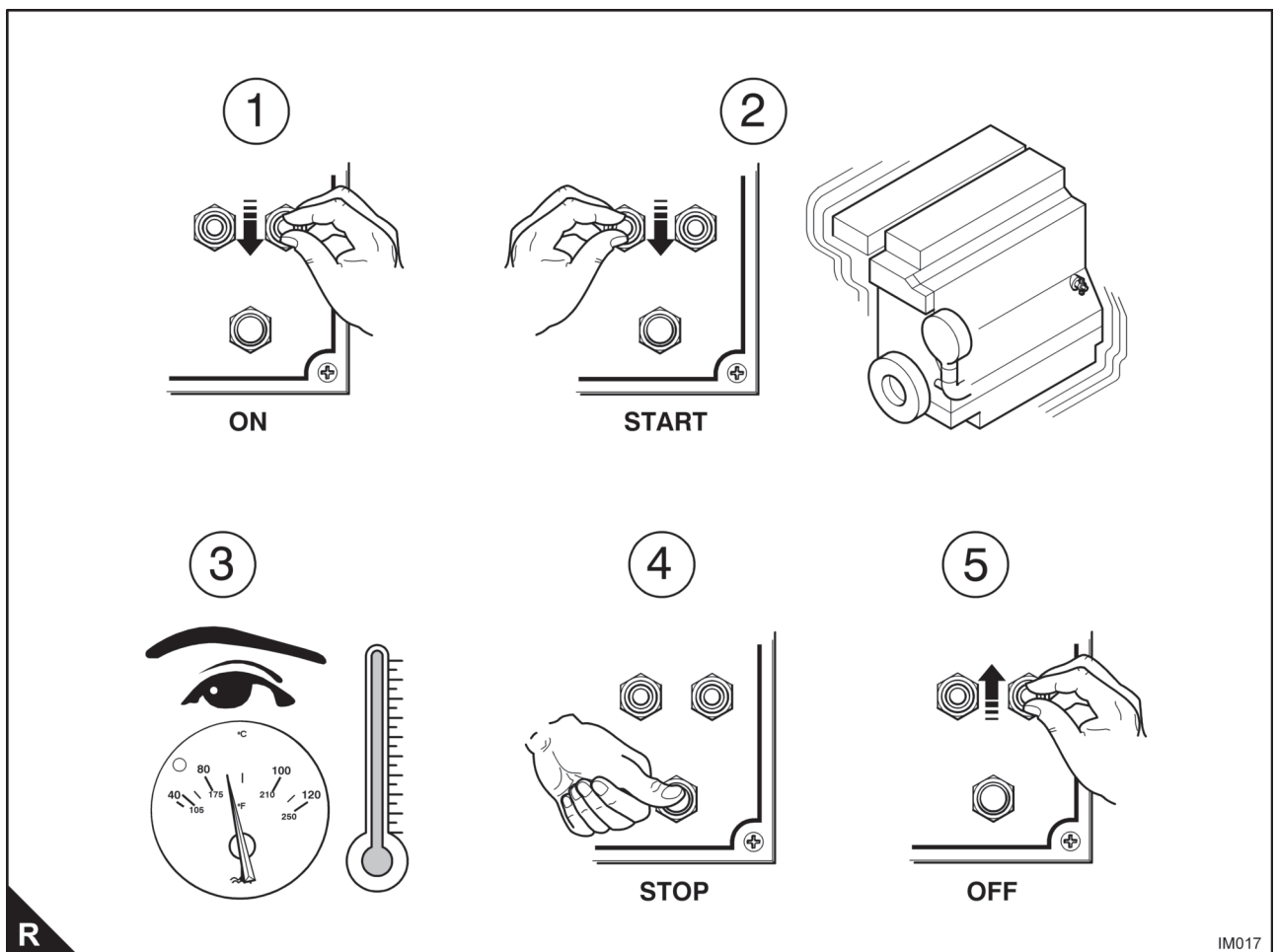

- 12. Check coolant level in the sight glass (S1)

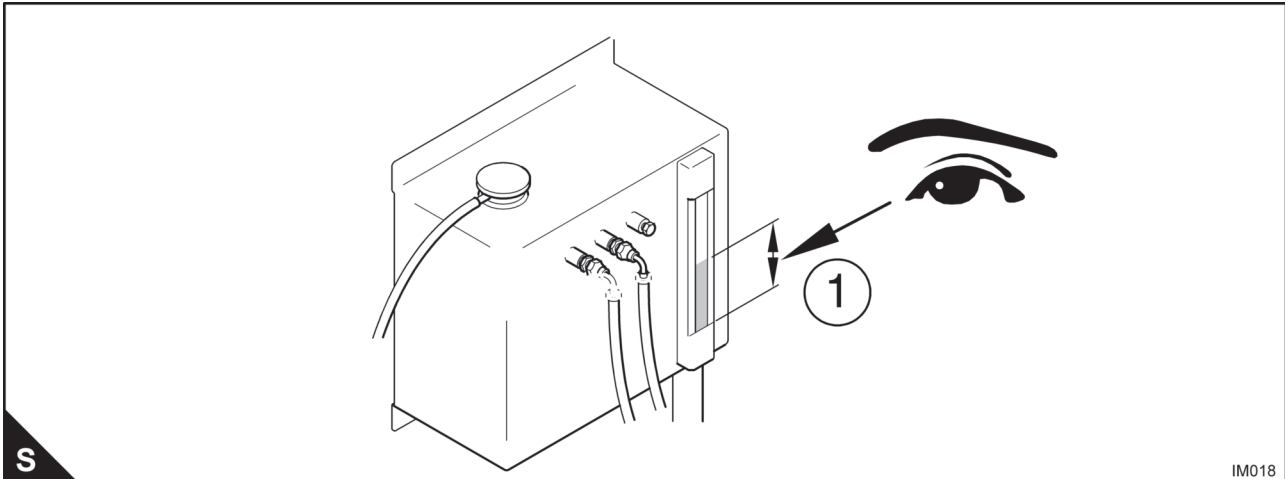

Warning! Hot coolant is under pressure and can cause severe burns when removing the pressure cap. First release the pressure in the system by loosening the pressure cap.

- 13. Top-up with 50% antifreeze to maximum level (T1).

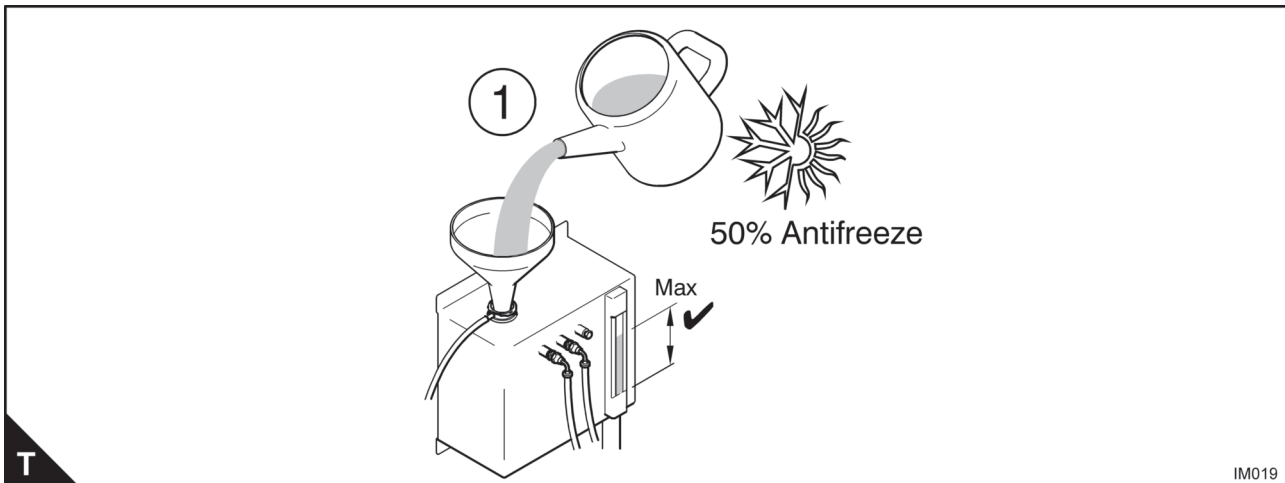

Power take-off (not optional on the 415GM, 422GM & 422TGM)

PTO Fitting Instructions

Key	Size	Torque
1	M12	100 Nm
2	7/16"	70 Nm
3	M10	55 Nm

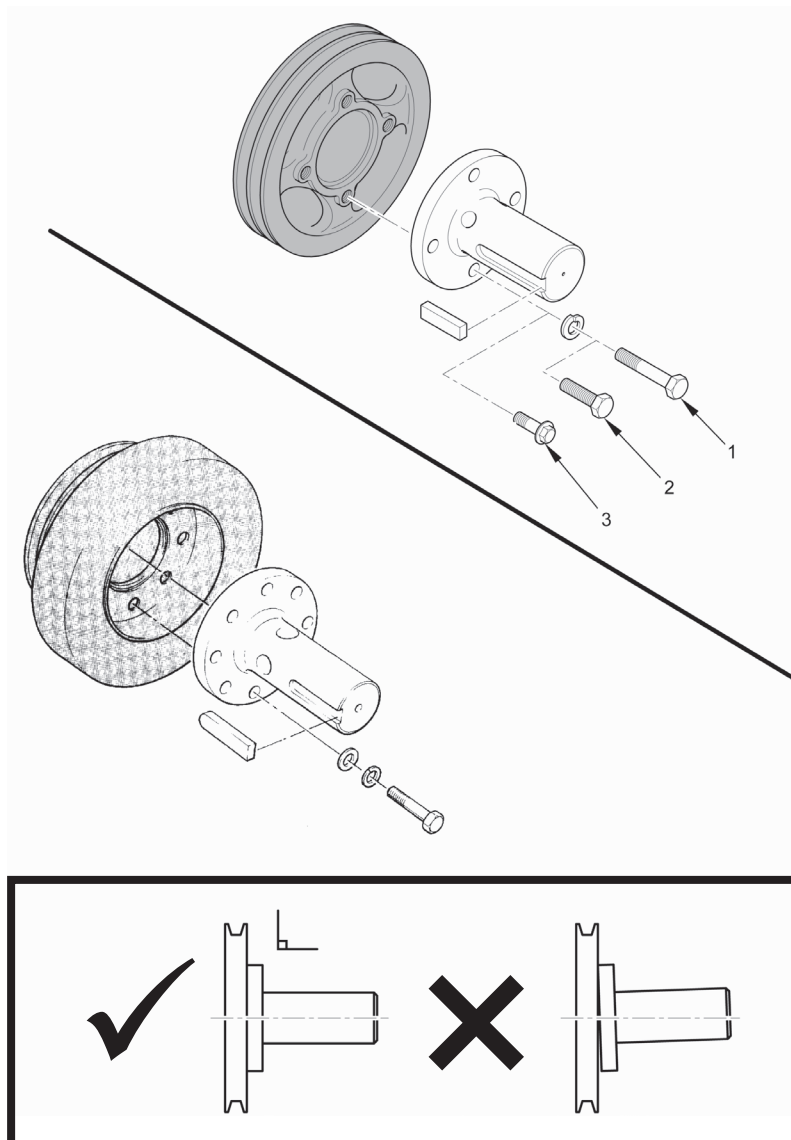

Note: Fitting the PTO should be undertaken by a qualified marine engineer.

Warning! For safety reasons, all moving parts should be shielded by a guard.

Belt drives - 4.4GM, 4.4TGM, 4.4TWGM and 4.4TW2GM only.

Standard options are:-

- Fenner 5" A section pulley with three grooves (A1) and taper lock (A2).
- or

- A Fenner 5" B section pulley with two grooves (A3) and taper locks (A4).

In this case the maximum power which can be taken will be limited by the belts, and it will be necessary to calculate for marginal applications.

Caution: Additional inertia must not be added to the P.T.O. shaft without specialist advice. Consult your distributor if you need advice about non-standard drive arrangements.

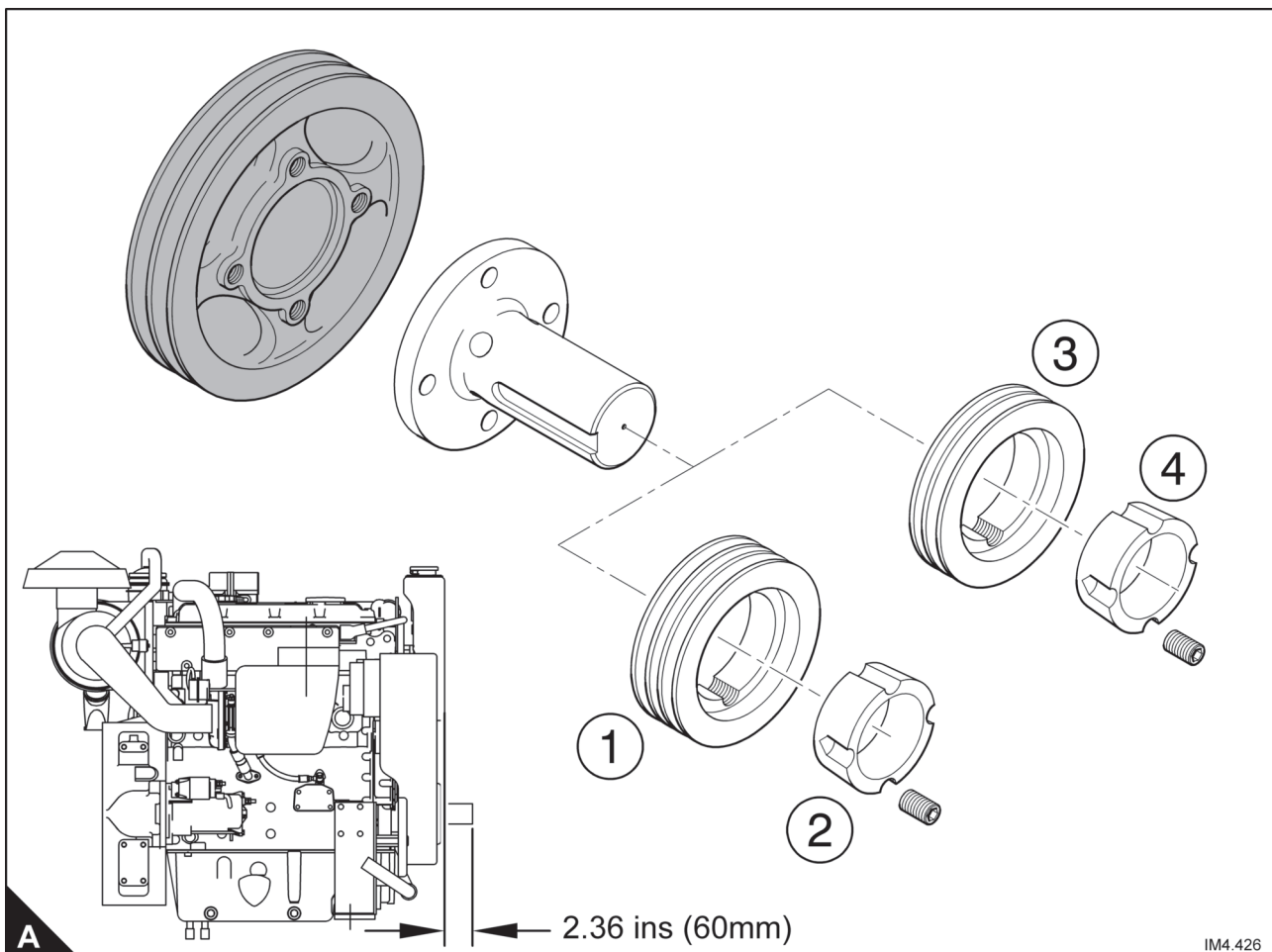

Belt drives - 700GM only.

Standard options are:-

- An A section pulley with three grooves (B1) at 195mm (7.7ins) diameter.
- or

- An A section pulley with one groove (B2) at 143mm (5.6ins) diameter.

In this case the maximum power which can be taken will be limited by the belts, and it will be necessary to calculate for marginal applications.

Caution: Additional inertia must not be added to the P.T.O. without specialist advice. Consult your distributor if you need advice about non-standard drive arrangements.

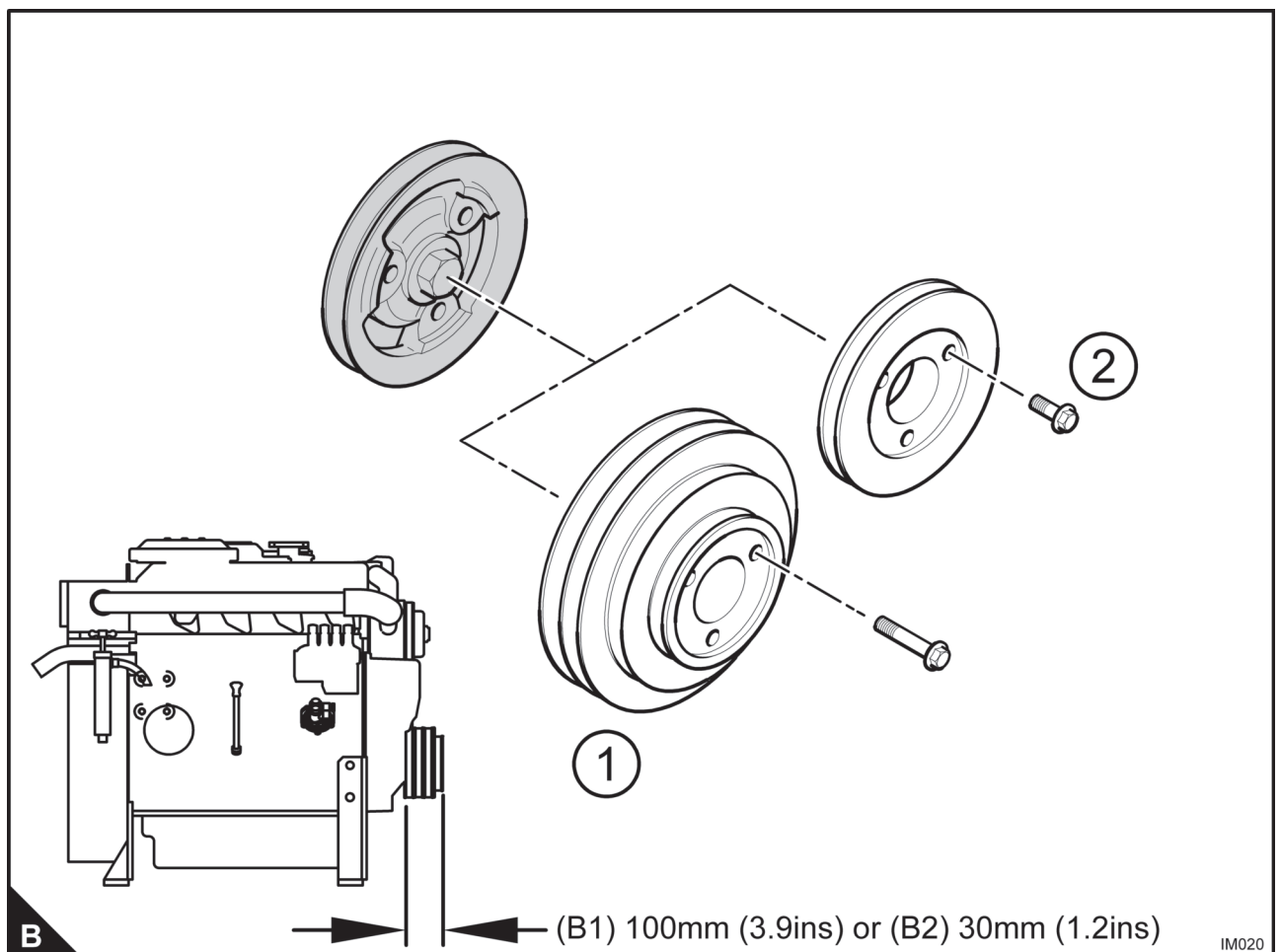

Belt drives - 4GM and 4TGM only.

Standard options are:-

- Fenner 5" A section pulley with three grooves (A1) and taper lock (A2).
- or

- A Fenner 5" B section pulley with two grooves (A3) and taper locks (A4).

In this case the maximum power which can be taken will be limited by the belts, and it will be necessary to calculate for marginal applications.

Caution: Additional inertia must not be added to the P.T.O. shaft without specialist advice. Consult your distributor if you need advice about non-standard drive arrangements.

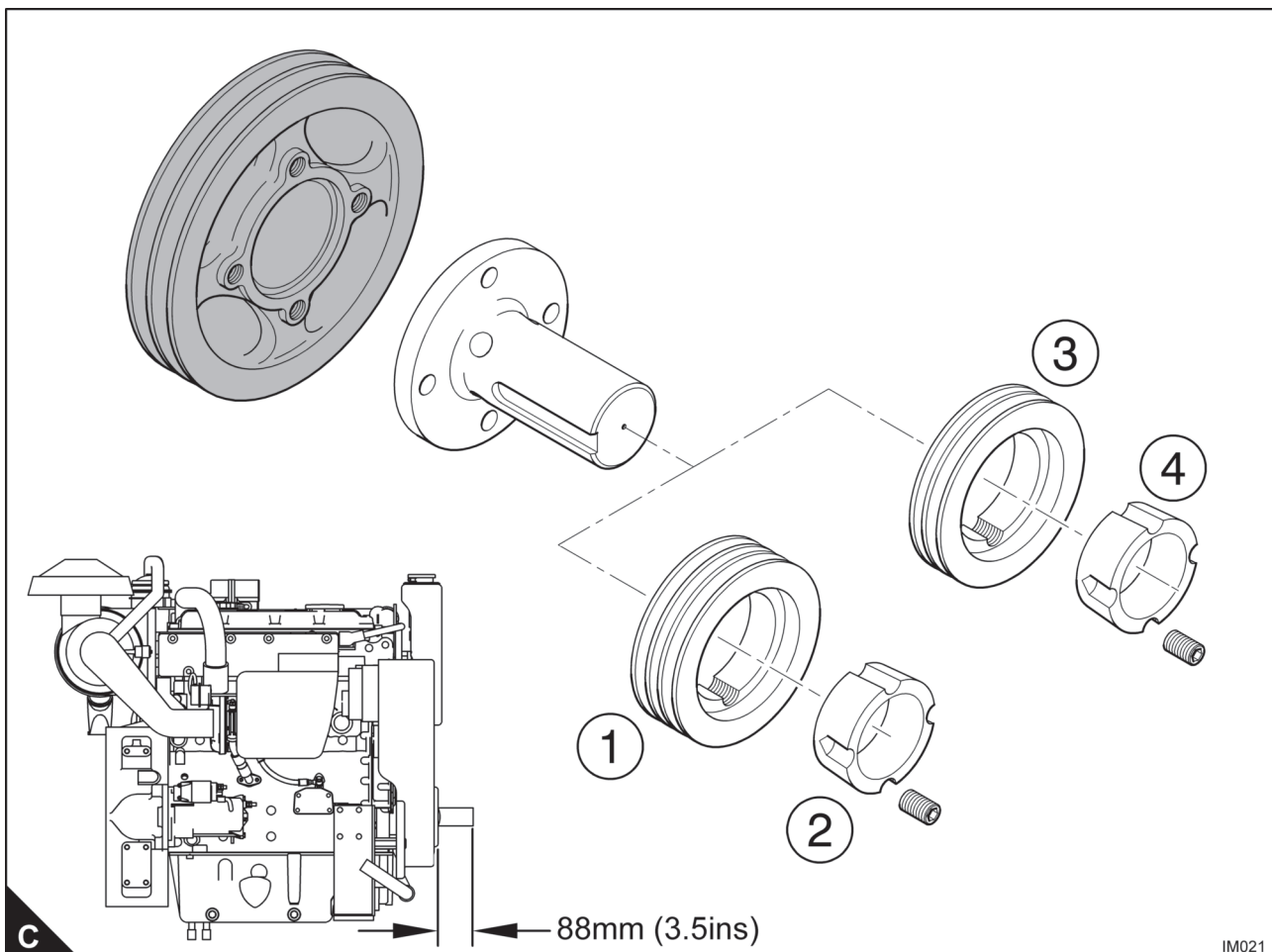

Belt drives - 6TG2AM and 6TWGM only.

Standard options are:-

- Fenner 5" A section pulley with three grooves (A1) and taper lock (A2).
- or

- A Fenner 5" B section pulley with two grooves (A3) and taper locks (A4).

In this case the maximum power which can be taken will be limited by the belts, and it will be necessary to calculate for marginal applications.

Caution: Additional inertia must not be added to the P.T.O. shaft without specialist advice. Consult your distributor if you need advice about non-standard drive arrangements.

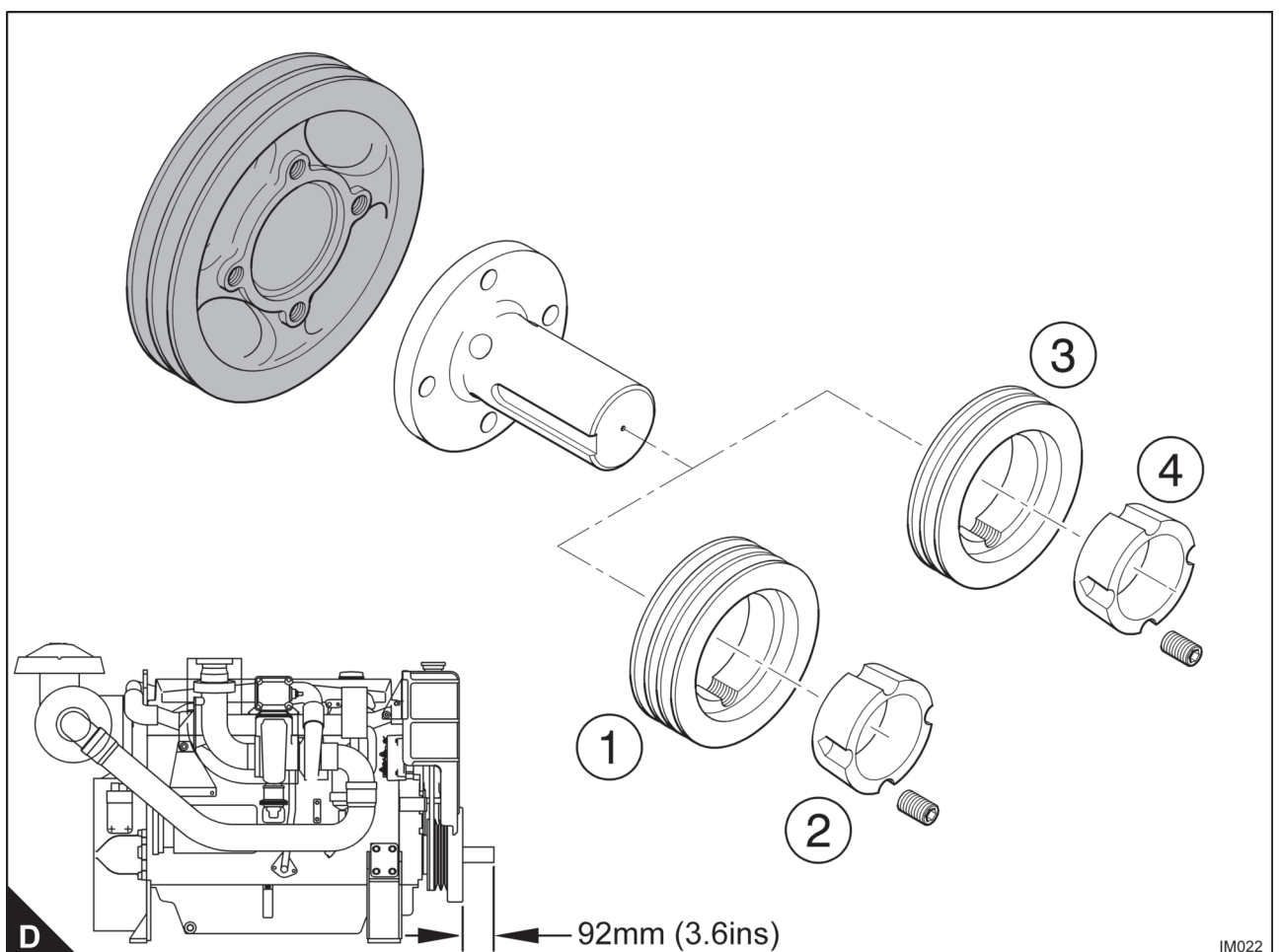

Electrolytic corrosion

Caution: The engine may be damaged by electrolytic corrosion (stray current corrosion) if the correct bonding procedure is not adopted.

Definition of galvanic and electrolytic corrosion.

Galvanic corrosion is caused when two different metals are immersed in a conductive fluid such as seawater (called electrolyte), with a connection between them, an electric current is generated in the same way as a battery.

Electrolytic corrosion (stray current corrosion) is caused by a current from an external source such as the boats battery or shore supply.

Avoiding electrolytic corrosion

The current that causes electrolytic action is called 'stray current' which can emanate from two sources.

The first is the batteries on board the vessel where the negative terminal is earthed to the hull at a central earth terminal. If other negative connections are made elsewhere on the vessel then the resulting small differences in voltage between the earth terminals can cause the same chemical action as in galvanic corrosion, but it must be stressed that this is not GALVANIC CORROSION but stray current known as electrolysis caused by an external electrical current.

The way to prevent electrolytic corrosion is to ensure a good electrical installation and to bond the genset to the bonding system in the boat which is providing a low resistance connection between all the metals in contact with the sea water. The bonding system should be connected to a zinc sacrificial anode that is fixed to the outside of the hull below sea level. A typical layout is shown in (A).

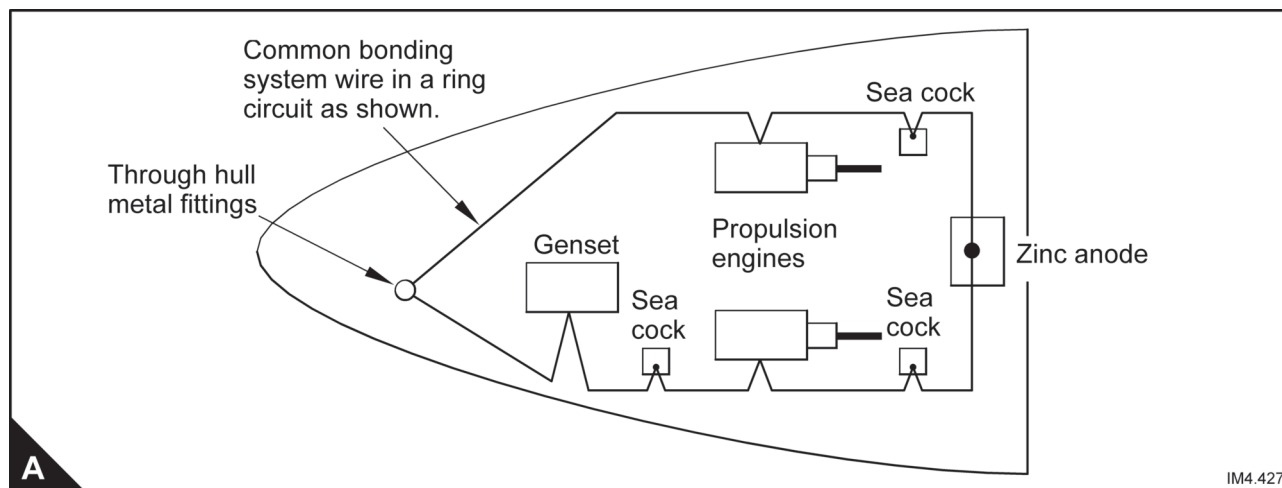

The bonding should consist of heavy stranded wire (not braiding or wire with fine strands). It is an advantage if the wire is tinned. Insulation is also an advantage and should preferably be green in colour. Although the current carried by the bonding system will not normally exceed 1 amp, the cable sizes should be generous as shown in the table below:

Length of run to zinc anode	Suggested cable size
Up to 30 feet	7 strand / 0.185mm (4mm ²)
30 - 40 feet	7 strand / 1.04mm (6mm ²)

As many of the connections may be splashed with sea water they should be soldered wherever possible and clamped elsewhere, with the joint protected from corrosion by neoprene paint, or a similar material, to exclude water.

Bonding of aluminium boats is a special case as the various appliances on board should be earth free and therefore to avoid stray currents all appliances must be earthed to a single terminal.

Grounding is required for safety if voltages are high, i.e. when there is a 240 volt generator on board or when a shore line is connected. Grounding (or earthing) must not be confused with the term 'earth return'. Earth return carries current, whereas grounding (earthing) does not.

Another source of unplanned current giving rise to a form of stray current corrosion is an earth connection from a shore line. When a shore line is in use the boat system should be protected from earth leakage by an earth leakage switch on shore but as additional safety there should be a switch on board the boat.

Caution: This section on bonding covers a typical system and has been included for guidance purposes only. It may not be appropriate for your boat. As installations vary, it is advised that specific recommendations from a specialist in the subject of electrolytic corrosion are obtained.

Zinc Anode bonding system

(a) Electrolytic corrosion within the engine cooling system and transmission can be much reduced or eliminated by bonding the engine to a Zinc anode which is used to protect through the hull metal fittings and other metal components that are in contact with sea water. The engine is fitted with a stud that may be used for this purpose. The stud is identified by a label, (B) shown below:

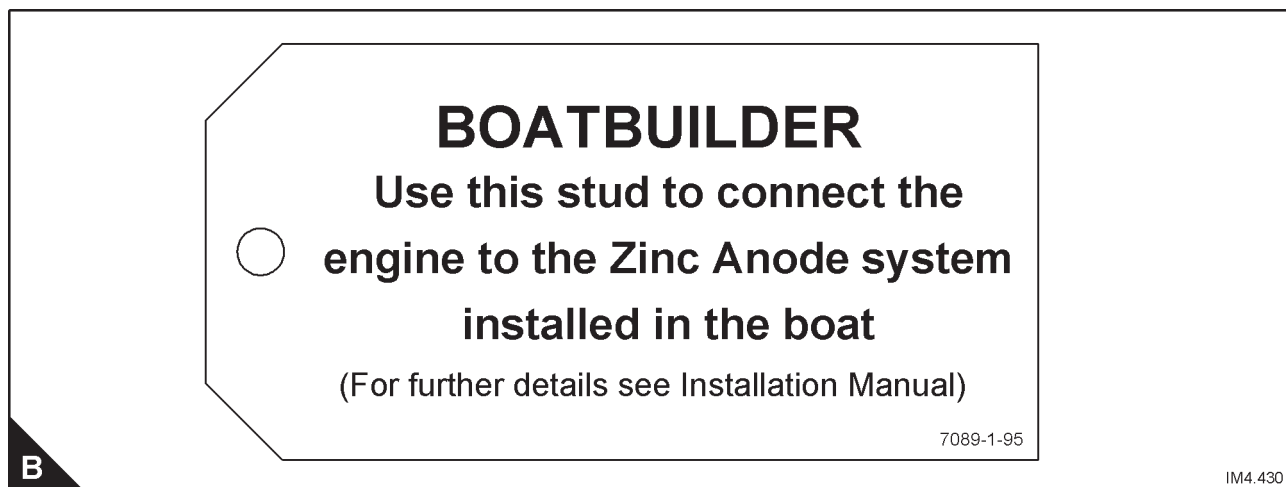

Battery and starter cables

(a) Batteries

There are two standards by which battery performance is commonly stated:-

- BS3911 uses the current which can be maintained for 60 seconds, without the voltage of a nominal 12V battery dropping below 8.4 volts, whilst at a temperature of -18°C .
- SAE J537 is similar except that the current is only maintained for 30 seconds and the voltage is allowed to fall to 7.2 volts.

Model	Batteries for temperatures down to -5°C (23°F)	
	12 Volt	24 Volt
415GM 422GM 422TGM	One battery - 520 Amps BS3911 or 800 Amps SAE J537	Two 12V batteries in series - each 315 Amps BS3911 or 535 Amps SAE J537
415GM 422GM 422TGM 700GM 4GM 4TGM	Two 12V batteries in parallel - each 315 Amps BS3911 or 535 Amps SAE J537	
700GM 4GM 4TGM 4.4GM 4.4TGM 4.4TWGM 4.4TW2GM 6TG2AM 6TWGM	One battery - 520 Amps BS3911 or 800 Amps SAE J537	Two 12V batteries in series - each 440 Amps BS3911
Batteries for temperatures down to -15°C (5°F)		
700GM 4GM 4TGM 4.4GM 4.4TGM 4.4TWGM 4.4TW2GM	Two 12V batteries in parallel, each 520 Amps BS3911 or 800 Amps SAE J537	Two 12V batteries in series, each 520 Amps BS3911 or 800 Amps SAE J537
415GM 422GM 422TGM 700GM 4GM 4TGM	Two 12V batteries in parallel - each 315 Amps BS3911 or 535 Amps SAE J537	Two 12V batteries in series - each 315 Amps or 535 Amps SAE J537

Note: Where starting at temperatures below freezing is an important requirement, a 24 volt system is the preferred choice

Starter cables for 12 or 24 volt systems								
*Maximum total length		Cable size metric	Nominal C.S.A.		Nominal resistance in ohms		Approx. equivalent size	
Metres	Feet		mm ²	in ²	Per metre	Per foot	English imperial	America B&S SAE
5.6	19.00	61/1,13	61	0.0948	0,000293	0.0000890	61/.044	00
9,0	28.30	19/2,52	95	0.1470	0,000189	0.0000600	513/.018	000

* The length of all cables in the starter circuit (whether positive or negative), should be added together to give the 'Total Length'

(b) Grounding the battery negative

It is recommended that the battery negative busbar is grounded as close as possible to the battery, by a substantial connection to the bonding system in the boat. This will reduce the likelihood of interference between items of electrical and electronic equipment fitted to the boat.

(c) Battery isolator switches

A switch should be fitted in the positive lead to the starter, as close to the battery as is convenient. The switch should be suitable for a momentary current of at least 1000 Amps.

Other electrical features 415GM, 422GM & 422TGM

Wiring loom derived from drawing number 02-1188-3

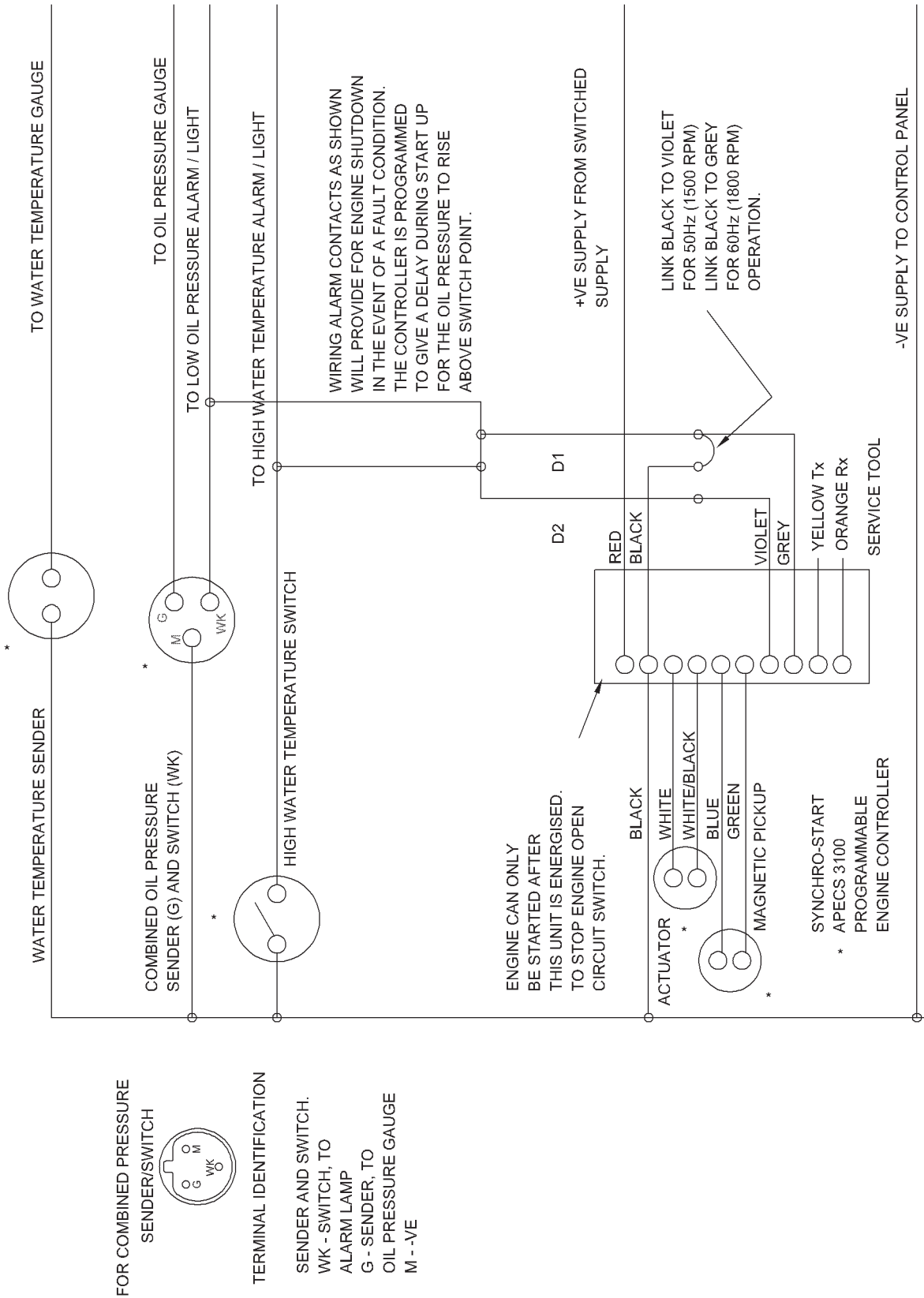

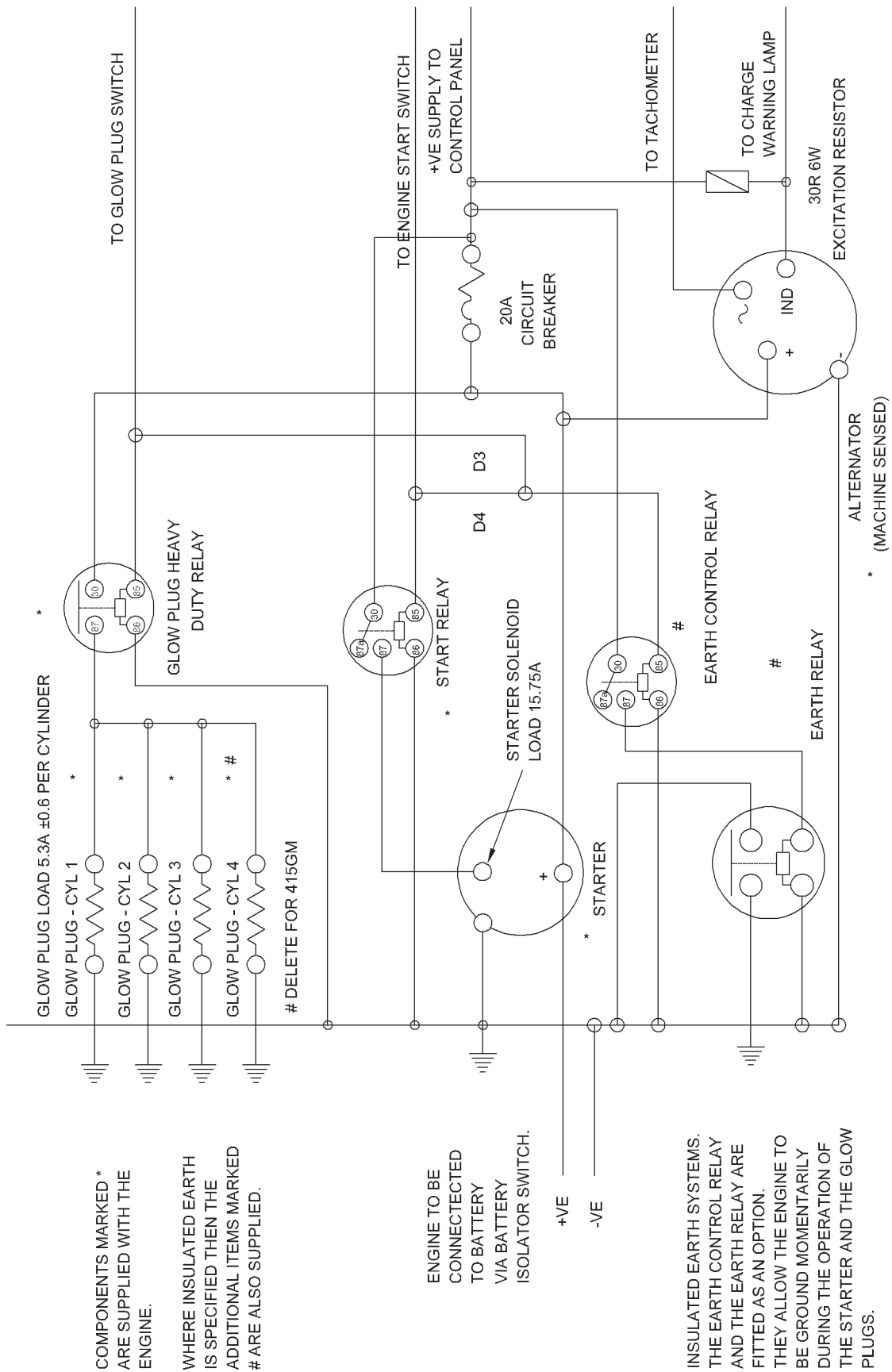

* COMPONENTS MARKED * ARE SUPPLIED WITH THE ENGINE.

WHERE INSULATED EARTH IS SPECIFIED THEN THE ADDITIONAL ITEMS MARKED # ARE ALSO SUPPLIED.

ENGINE TO BE CONNECTED TO BATTERY VIA BATTERY ISOLATOR SWITCH.

INSULATED EARTH SYSTEMS. THE EARTH CONTROL RELAY AND THE EARTH RELAY ARE FITTED AS AN OPTION. THEY ALLOW THE ENGINE TO BE GROUND MOMENTARILY DURING THE OPERATION OF THE STARTER AND THE GLOW PLUGS.

APECS calibration tool (ACT) part number 36204

Refer to the figure (C) for setting up the ACT for APECS calibration. The ACT software can be run from the 3.5" floppy disk supplied with the kit. You can also install the ACT software on your personal computer (please refer to the APECS 3000 user's manual SE-3872).

Note: The APECS unit must be powered up, but need not be mounted on the engine to carry out the calibration procedure.

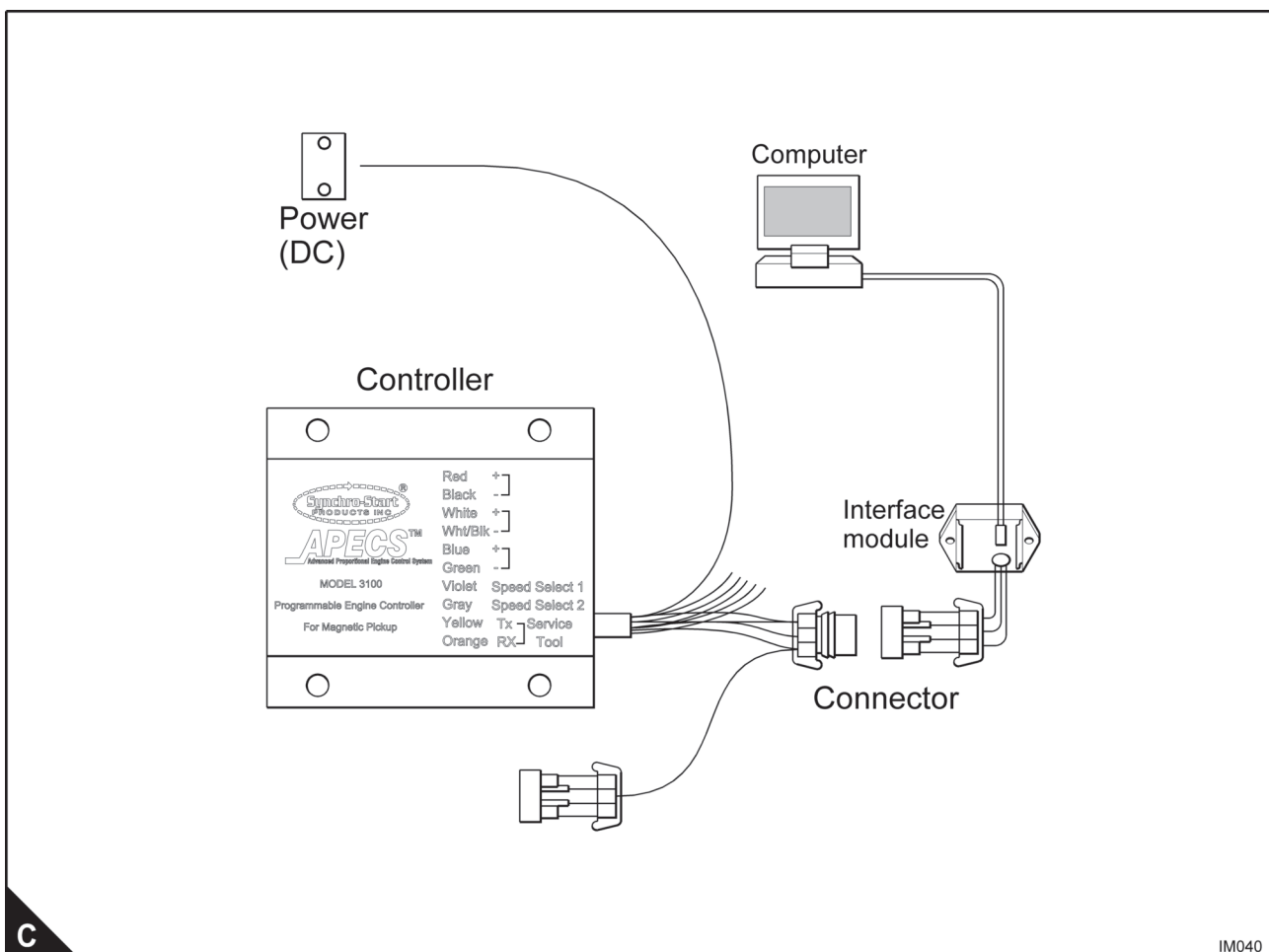

Electronic governor overview

The engines are fitted with both mechanical and electronic governors. The electronic governor controls the engine speed within $\pm 0.25\%$.

If the electronic governor fails, the mechanical governor will control the maximum engine speed to 2050 rev/min.

The electronic governor is made up of three parts:

1. The engine speed controller is set at the factory or can be adjusted using a laptop computer and data link.
2. The actuator - This is fitted to the fuel injection pump and controls the engine speed.
3. The electro-magnetic sensor - This is fitted to the flywheel housing and measures the engine speed.

Caution: *Ensure that the electro-magnetic sensor is set correctly, and the cables are connected in accordance with the wiring diagram. Ensure that there is electrical continuity between the frame for the engine and the frame for the control panel.*

Electronic governor in detail

The Synchro-Start APECS® (Advanced Proportional Engine Control System) series 3000 is an isochronous engine governor that provides a means of controlling and limiting engine speed. The controller is set up using an APECS Calibration Tool (ACT, part number 36204). The ACT is computer based software that can be used for monitoring and is available separately.

Controller installation and wiring diagram

- Use the drawing (D) and table to install and wire the controller
- Connect power leads directly to the switched power source. Use of a 10 amp slow-blow fuse is recommended in the battery (positive) wire.
- Use proper terminations and crimping techniques to avoid elevated resistance and shorts.
- Use of convoluted tubing or other wire shielding is recommended to minimize mechanical damage to the wires. Avoid sharp edges and pinching when routing wires.
- Mount the controller in a location where the effects of vibration and temperature are minimal.

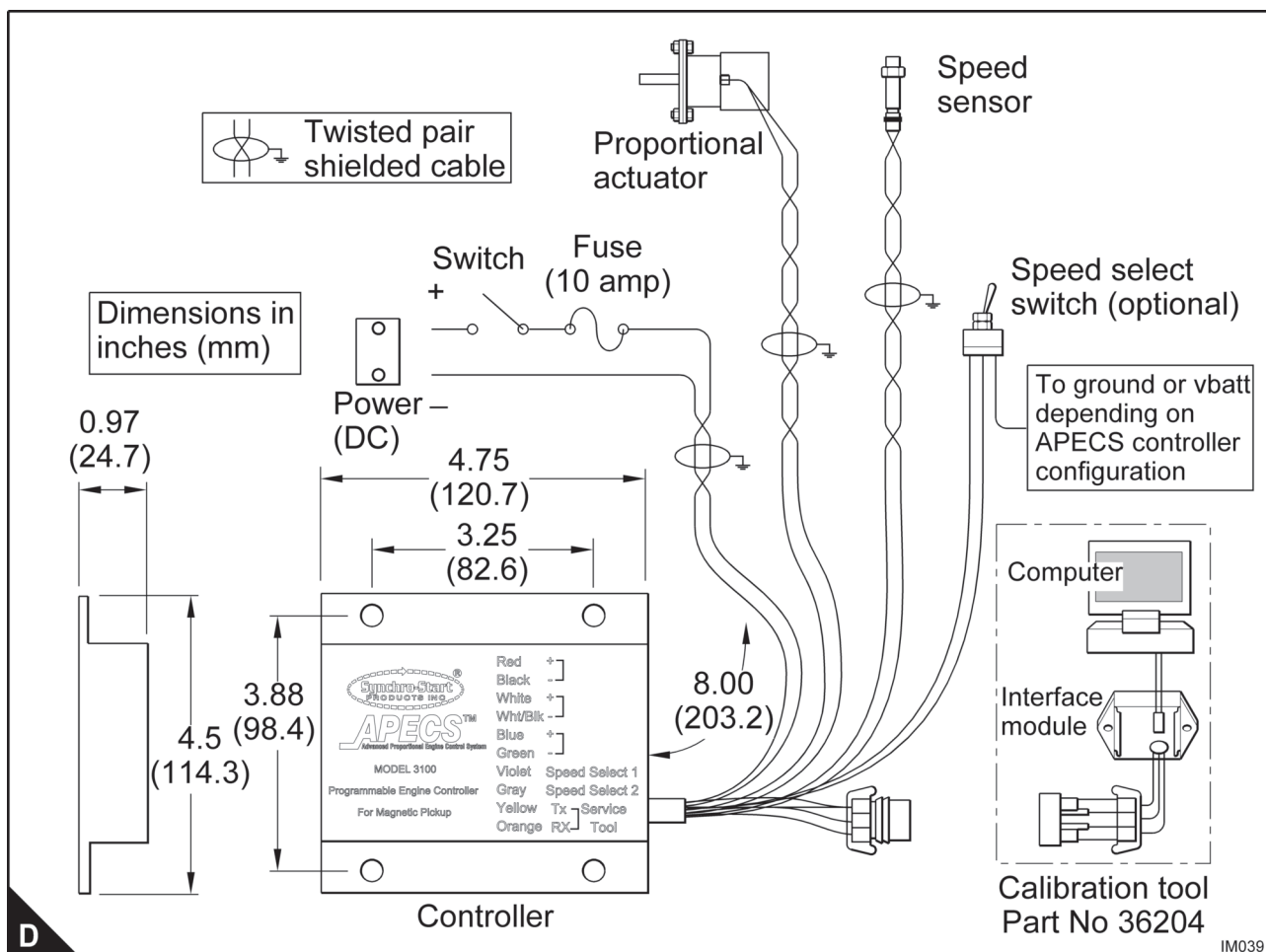

Controller wiring table

	Model 3100
Battery	Red + Black -
Actuator	White + White/Black -
Speed signal input	<u>Magnetic pickup</u> Blue + Green -
1500 (50Hz)	Violet
1800 (60Hz)	Gray
Service tool	Yellow Tx Orange Rx

System wiring

Resistance in the wiring, due to inadequate wire gauge or excessive wire length, will result in insufficient force from the actuator. The table shows the recommended gauges and maximum lengths of wires. Wire length is the total length used to connect the actuator to the controller and controller to the system power.

System wiring table		
AWG14 (2.50mm ²)	AWG16 (1.50mm ²)	AWG18 (1.00mm ²)
66ft (20m)	33ft (10m)	22ft (6.7m)

Other electrical features 700GM

Wiring loom derived from document number 5153-1-02

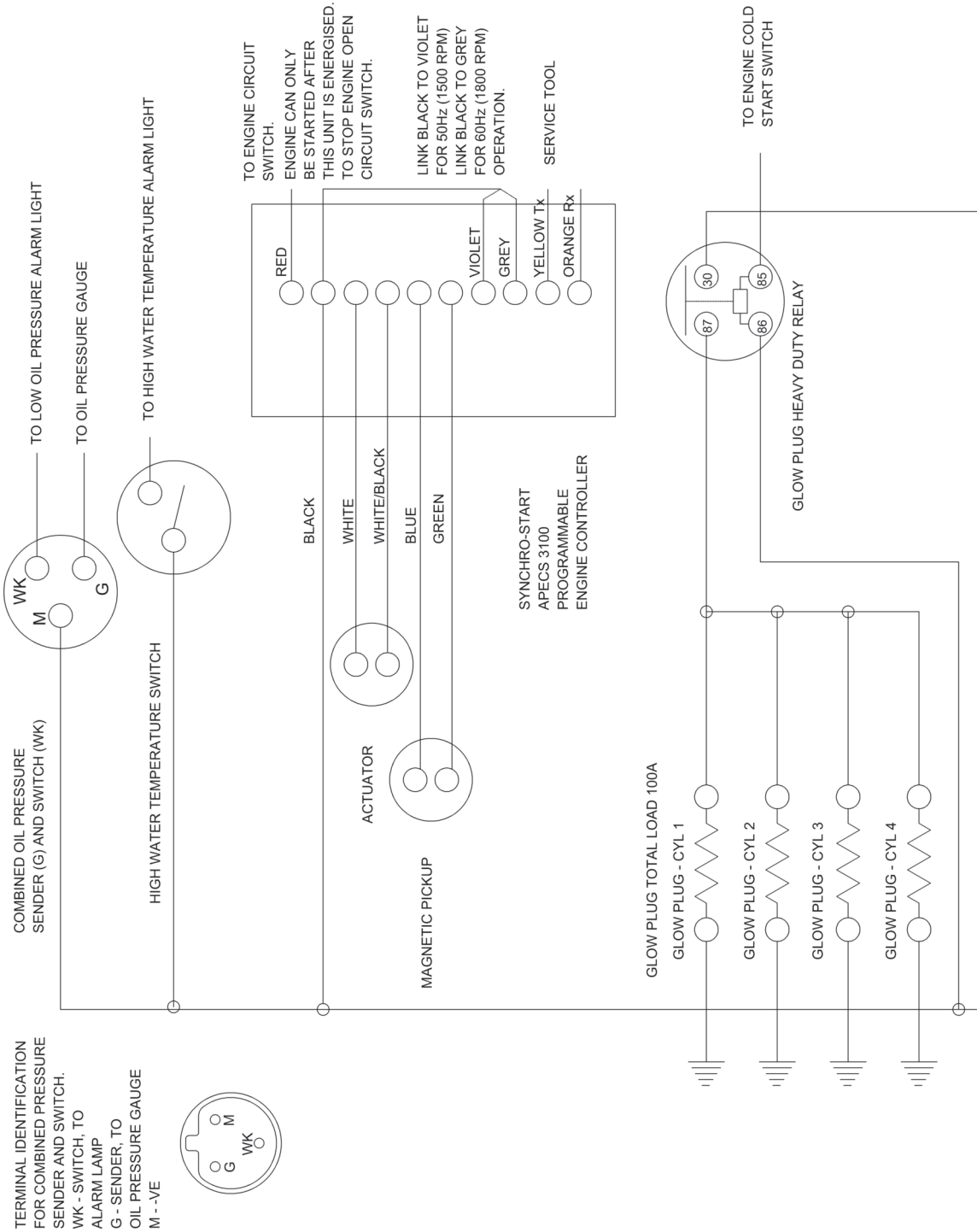

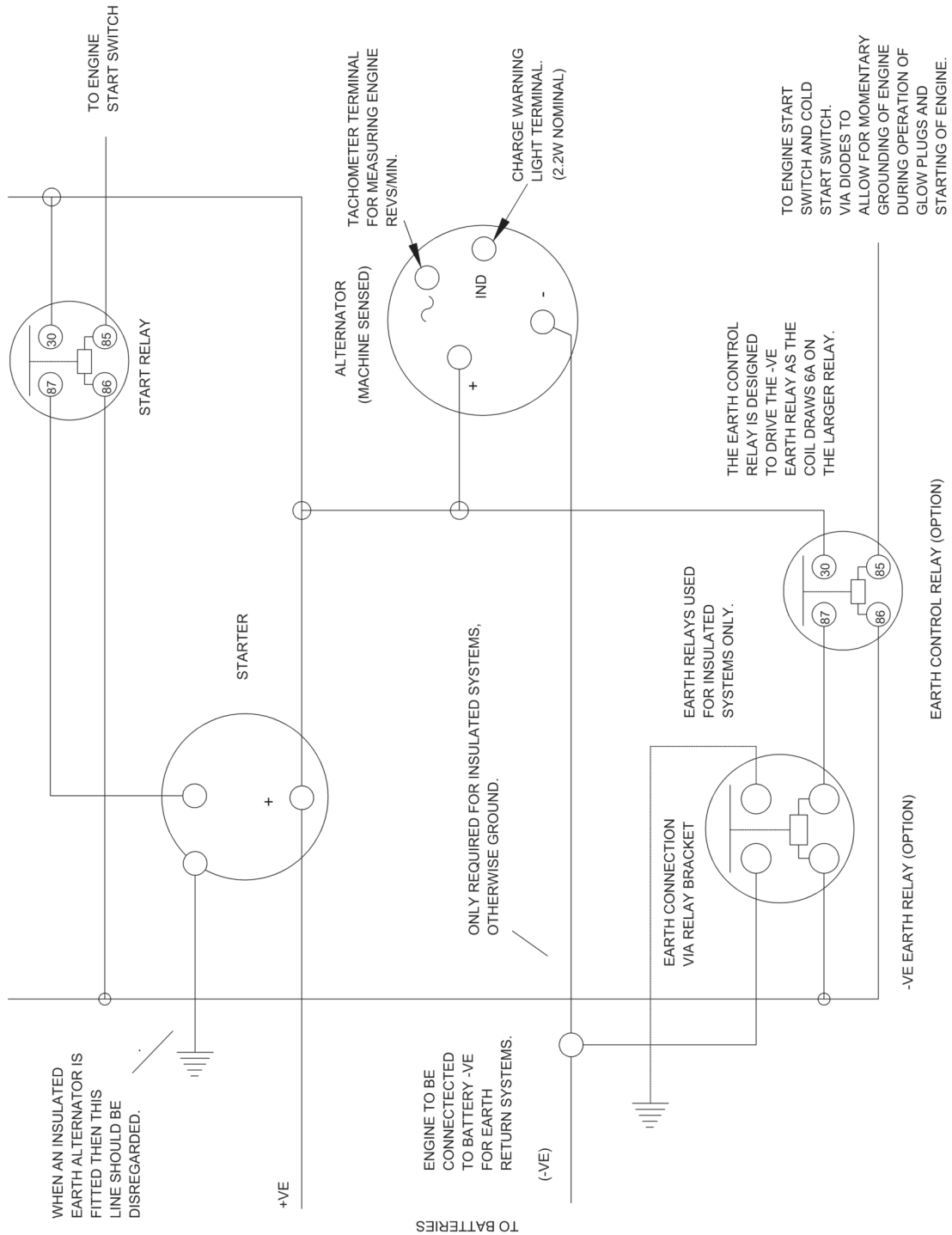

NOE THIS CIRCUIT SHOWS THE BASIC SCHEME USING PARTS SUPPLIED WITH THE ENGINE. ALL CIRCUITS SHOULD BE PROTECTED BY FUSES OR CIRCUIT BREAKERS.

APECS calibration tool (ACT) part number 36204

Refer to the figure (E) for setting up the ACT for APECS calibration. The ACT software can be run from the 3.5" floppy disk supplied with the kit. You can also install the ACT software on your personal computer (please refer to the APECS 3000 user's manual SE-3872).

Note: The APECS unit must be powered up, but need not be mounted on the engine to carry out the calibration procedure.

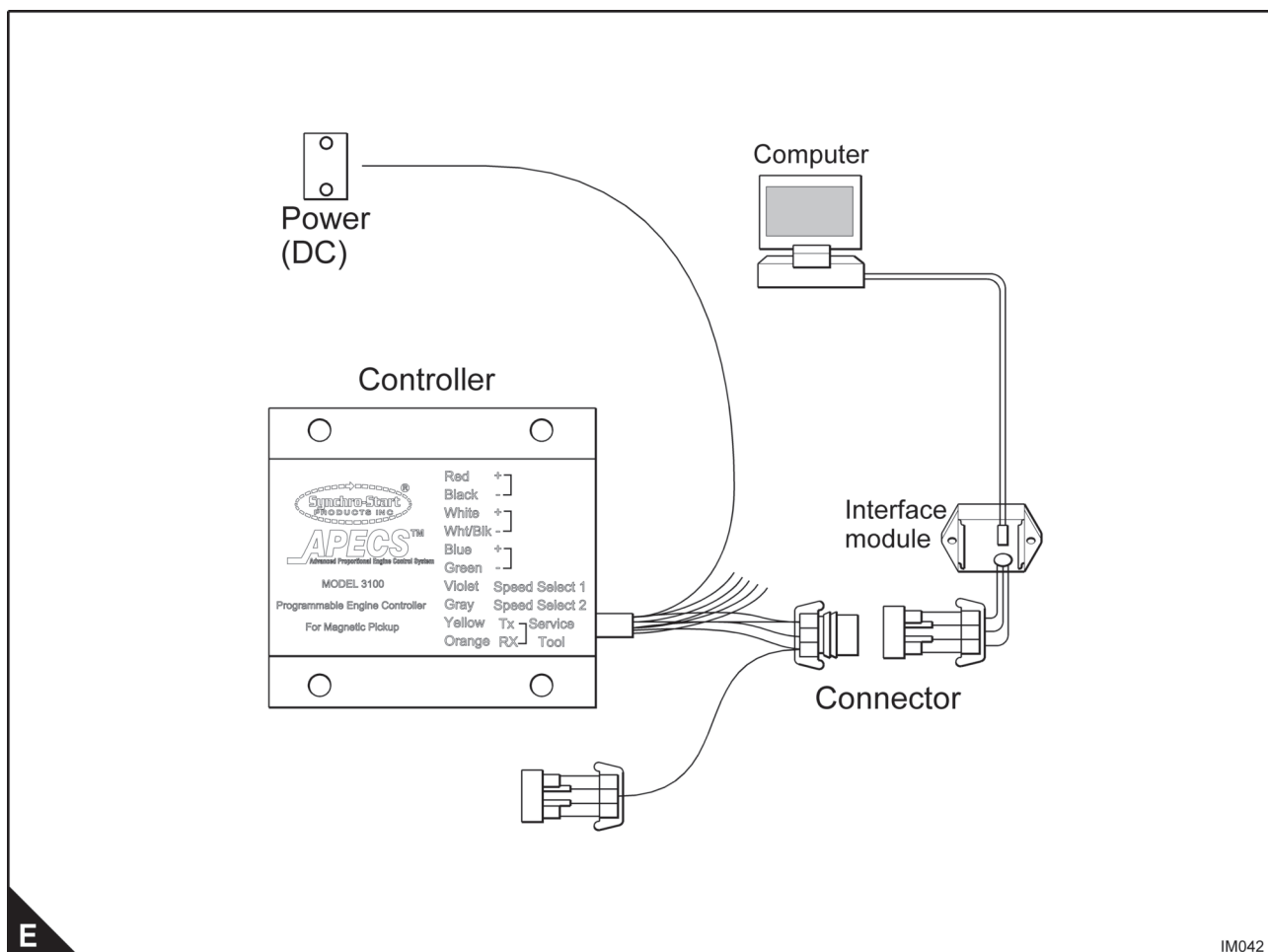

Electronic governor overview

The engines are fitted with both mechanical and electronic governors. The electronic governor controls the engine speed within $\pm 0.25\%$.

If the electronic governor fails, the mechanical governor will control the maximum engine speed to 2050 rev/min.

The electronic governor is made up of three parts:

1. The engine speed controller is set at the factory or can be adjusted using a laptop computer and data link.
2. The actuator - This is fitted to the fuel injection pump and controls the engine speed.
3. The electro-magnetic sensor - This is fitted to the flywheel housing and measures the engine speed.

Caution: *Ensure that the electro-magnetic sensor is set correctly, and the cables are connected in accordance with the wiring diagram. Ensure that there is electrical continuity between the frame for the engine and the frame for the control panel.*

Electronic governor in detail

The Synchro-Start APECS® (Advanced Proportional Engine Control System) series 3000 is an isochronous engine governor that provides a means of controlling and limiting engine speed. The controller is set up using an APECS Calibration Tool (ACT, part number 36204). The ACT is computer based software that can be used for monitoring and is available separately.

Controller installation and wiring diagram

- Use the drawing (F) and table to install and wire the controller
- Connect power leads directly to the switched power source. Use of a 10 amp slow-blow fuse is recommended in the battery (positive) wire.
- Use proper terminations and crimping techniques to avoid elevated resistance and shorts.
- Use of convoluted tubing or other wire shielding is recommended to minimize mechanical damage to the wires. Avoid sharp edges and pinching when routing wires.
- Mount the controller in a location where the effects of vibration and temperature are minimal.

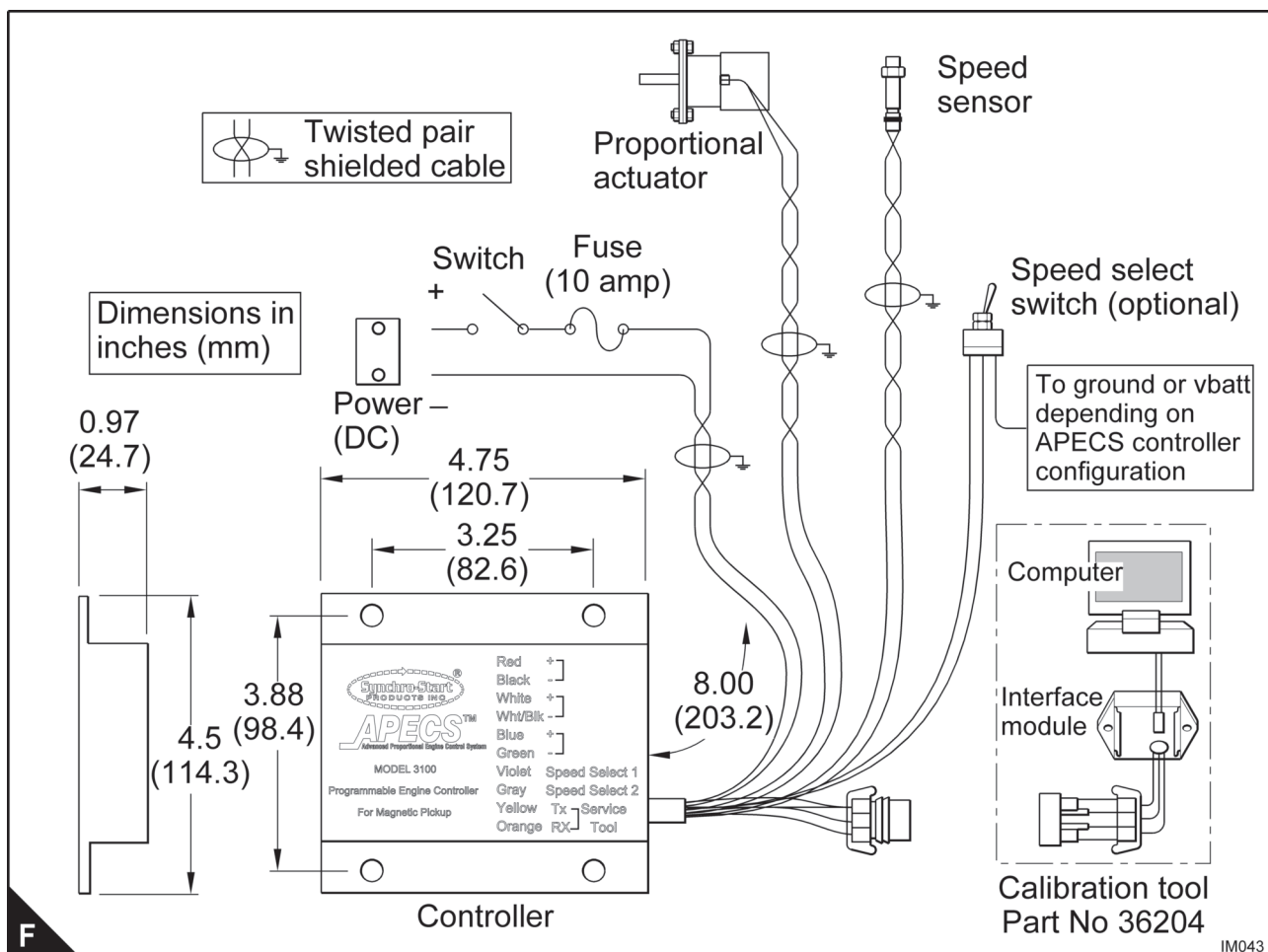

F

IM043

Controller wiring table

	Model 3100
Battery	Red + Black -
Actuator	White + White/Black -
Speed signal input	<u>Magnetic pickup</u> Blue + Green -
1500 (50Hz)	Violet
1800 (60Hz)	Gray
Service tool	Yellow Tx Orange Rx

System wiring

Resistance in the wiring, due to inadequate wire gauge or excessive wire length, will result in insufficient force from the actuator. The table shows the recommended gauges and maximum lengths of wires. Wire length is the total length used to connect the actuator to the controller and controller to the system power.

System wiring table		
AWG14 (2.50mm ²)	AWG16 (1.50mm ²)	AWG18 (1.00mm ²)
66ft (20m)	33ft (10m)	22ft (6.7m)

Other electrical features 4GM & 4TGM

Wiring loom derived from document number 97-1084-3

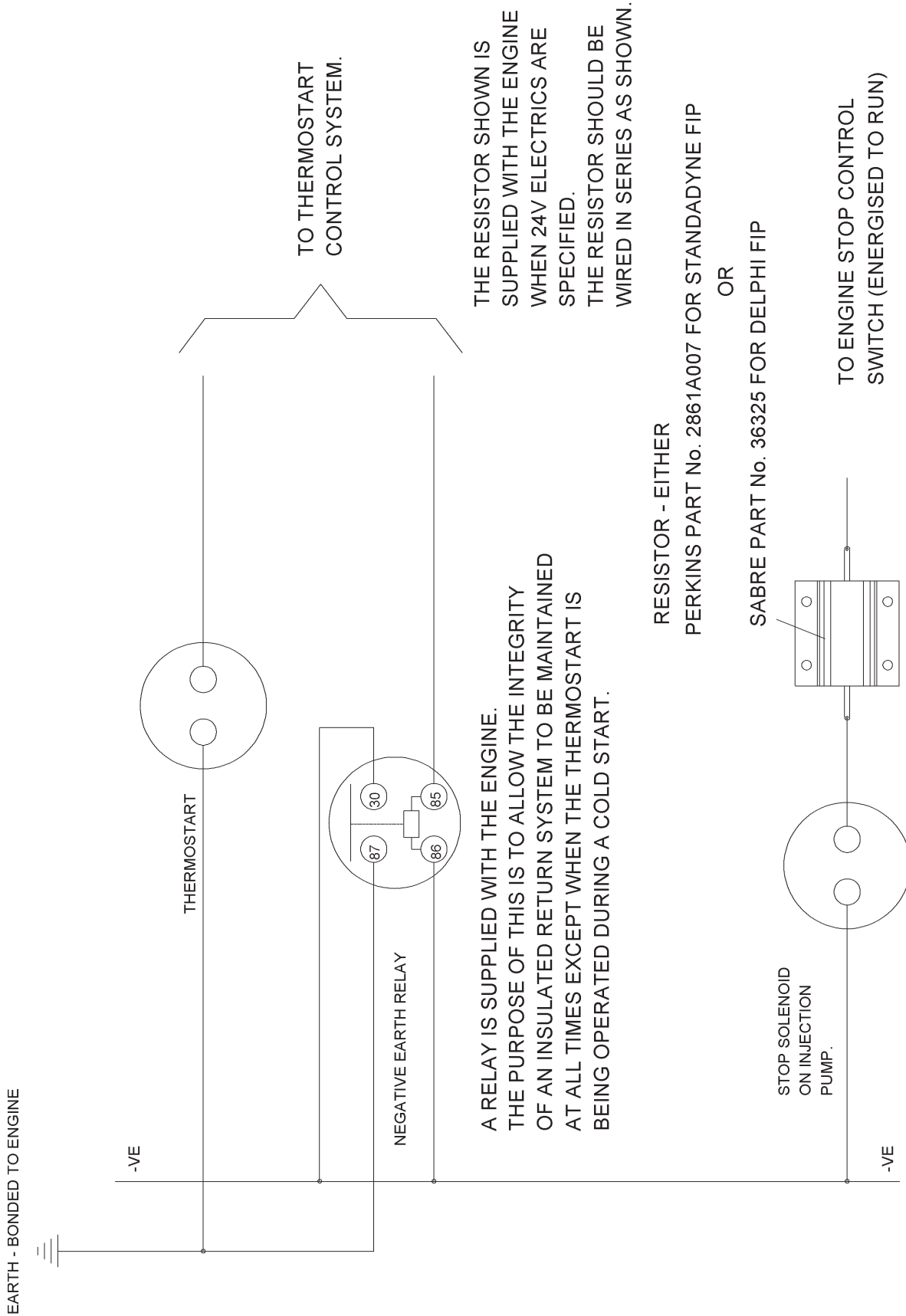

THE RESISTOR SHOWN IS SUPPLIED WITH THE ENGINE WHEN 24V ELECTRICS ARE SPECIFIED. THE RESISTOR SHOULD BE WIRED IN SERIES AS SHOWN.

A RELAY IS SUPPLIED WITH THE ENGINE. THE PURPOSE OF THIS IS TO ALLOW THE INTEGRITY OF AN INSULATED RETURN SYSTEM TO BE MAINTAINED AT ALL TIMES EXCEPT WHEN THE THERMOSTART IS BEING OPERATED DURING A COLD START.

RESISTOR - EITHER PERKINS PART No. 2861A007 FOR STANDADYNE FIP OR SABRE PART No. 36325 FOR DELPHI FIP

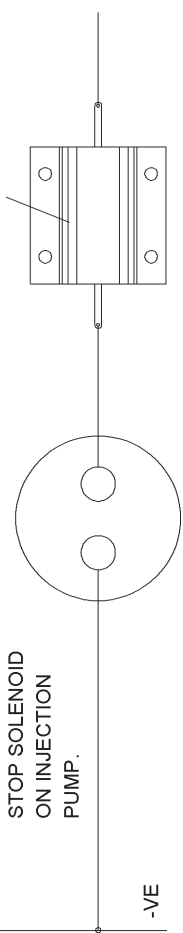

L Series electronic governor guidelines

A pinout of the L Series governor, as viewed into the control connector, is shown below (G). This information derived from document 5198-1-05.

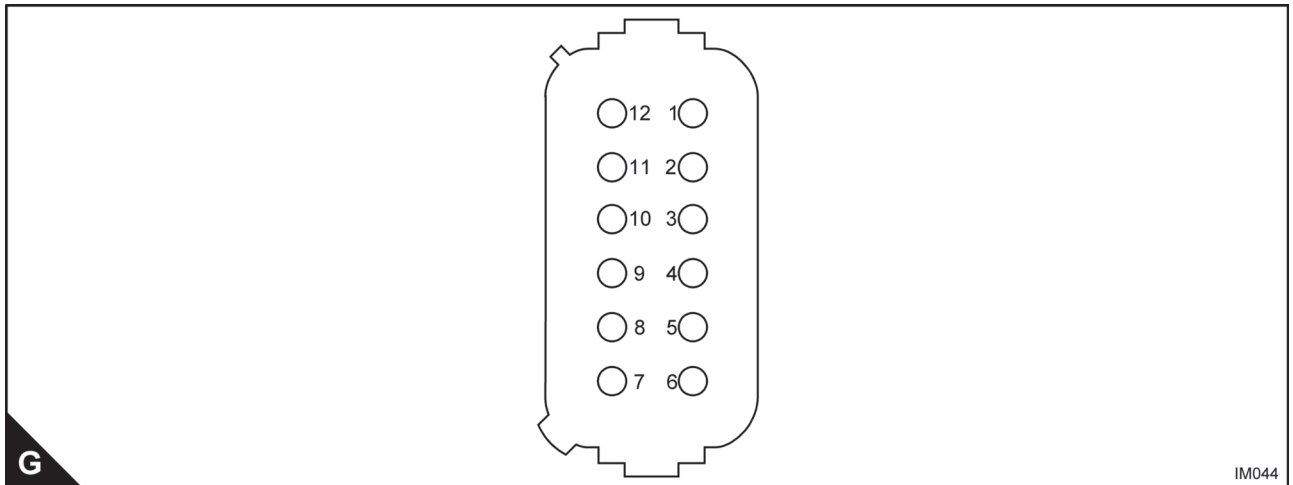

Connector pin#	Description	Comment
1	+12/24 VDC input power	Supply power
2	TPS signal output	Direct position feedback output indication
3	AUX - (sig gnd)	Ground for AUX inputs
4	Aux input 3 / RS-232 transmit	Combination Aux 3 and service tool input
5	Input power ground	Ground for the 12/24V input power
6	Aux input 4 / RS-232 receive	Combination Aux 4 and service tool input
7	5V out	Power for external sensors (10mA max)
8	Aux input 1	Aux 1 input
9	Relay driver output	Status / fault detection output
10	Aux input 2	Aux 2 input
11	MPU +	MPU speed signal input
12	Ignition input	Ignition speed signal input

Note: If any features are not required in the application, the related wiring may be omitted.

Other electrical features 4.4GM, 4.4TGM, 4.4TWGM & 4.4TW2GM

Wiring loom derived from document number 04-1006-1

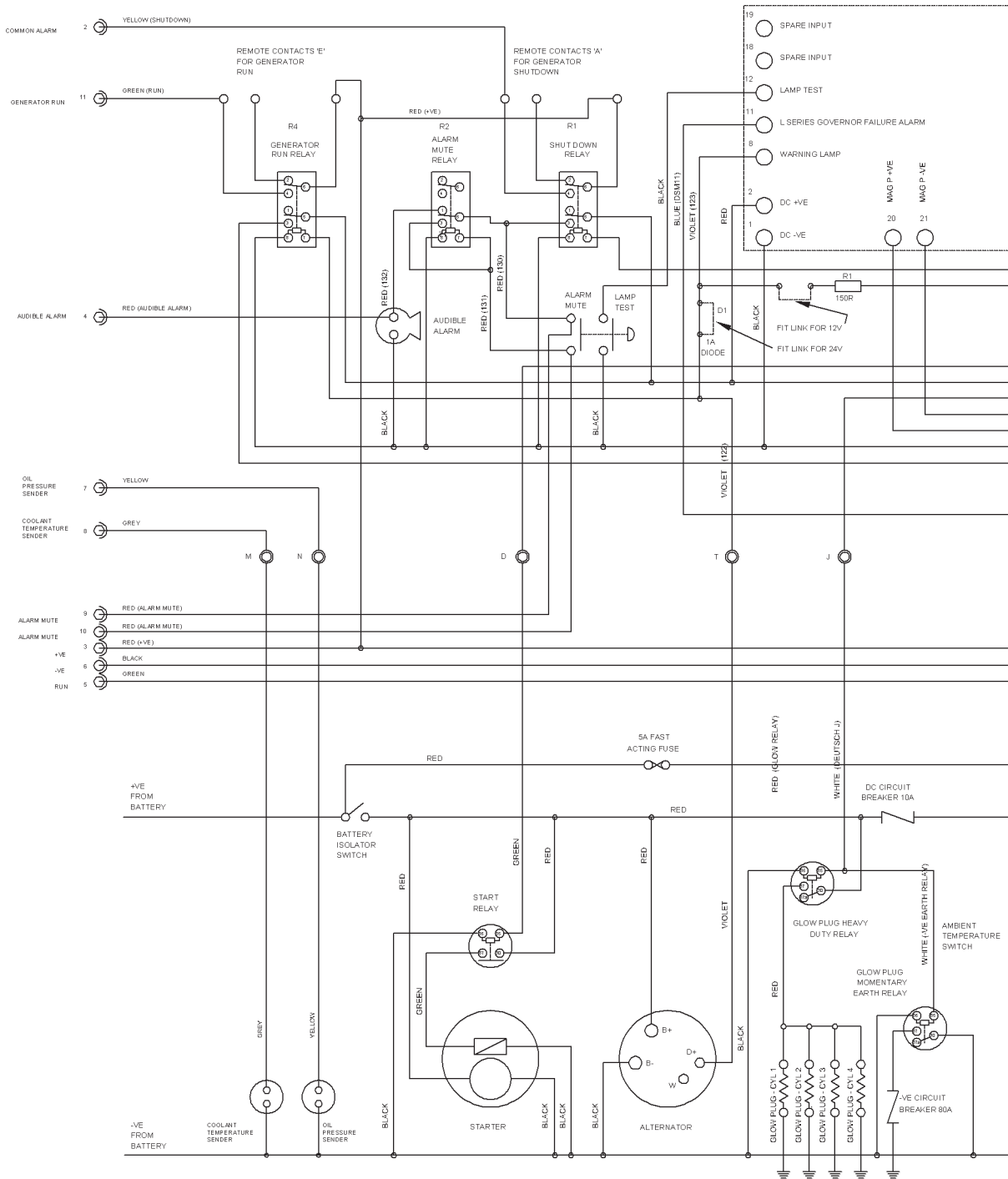

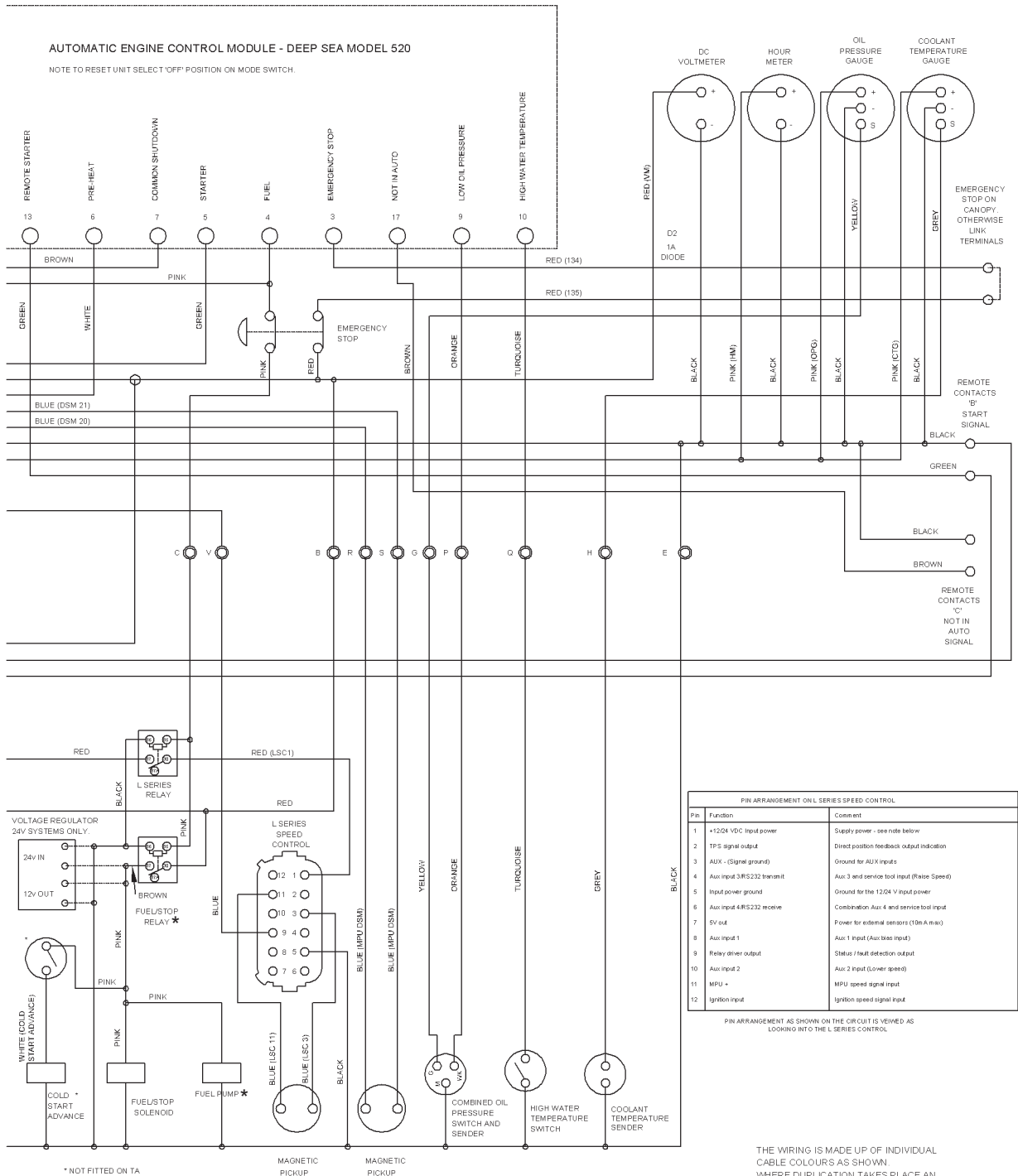

THE WIRING IS MADE UP OF INDIVIDUAL CABLE COLOURS AS SHOWN. WHERE DUPLICATION TAKES PLACE AN ADDITIONAL IDENTIFICATION IS PRINTED ON TO THE CABLE AS SHOWN IN

***Stop Solenoid and Fuel Lift Pump are 12v only**

Standard control system (optional on 4.4 range)

A standard control system is available when used with a factory supplied engine wiring harness, that allows for the control of the genset including start and stop functions, which can be performed remotely with the appropriate panel. The control module is able to display any fault condition that may occur with automatic shutdowns being available where programmed. The main control also includes three analogue gauges, indicating the operational status of the engine.

The automatic engine control module contains the following features:

The following relay outputs are provided:

- Fuel solenoid output
- Start output
- Pre-heat
- Common shutdown
- Not in auto

The following inputs are provided:

- Governor failure alarm
- Lamp test
- Two spare inputs

Multiple alarm channels are provided to monitor the following:

- Under/overspeed
- DC alternator charge fail
- Emergency stop
- Low oil pressure
- High coolant temperature
- Fail to start
- Loss of speed sensing

The standard control can be mounted remotely if required. This is achieved by using a 4.57m (15ft) extension lead which is inserted between the connectors at the rear of the control box. This places the extension lead in series with the two connectors, one from the engine and the other in the rear of the control box.

Voltage Converter Fitting Instructions

Note: The voltage converter must not be engine mounted and is supplied with an extension lead for this purpose.

1. Select a cool, dry and ventilated position.
2. Use the bracket to mark the position of the holes.
3. Drill 3.5mm holes.
4. Fix the clip using screws provided.
5. Click the unit onto the clip.
6. First connect both input wires. Second connect the output wires.
7. Max. temp. 55°C. Mount unit remote from engine in a cool, dry and ventilated position.

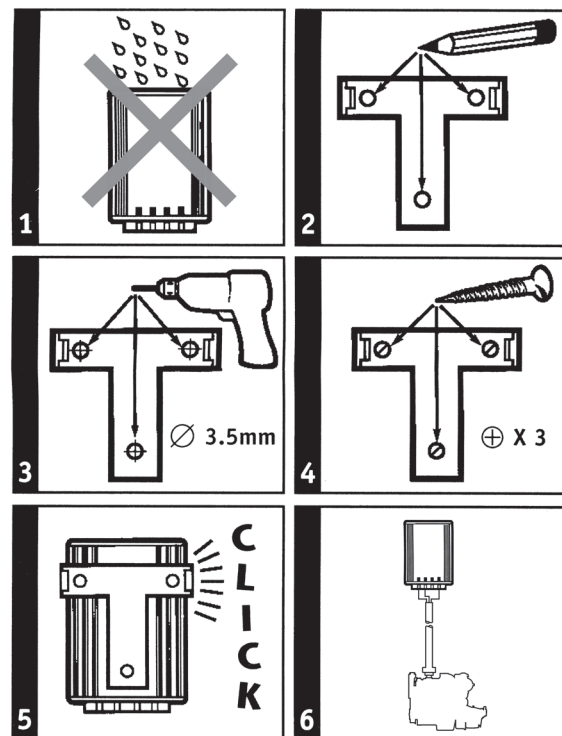

For the 4.4 range of engines supplied without a loom

For the 4.4 range of engines supplied without a loom a connector is provided for the L Series speed controller. This information derived from drawing 05-1257-3

A pinout of the L Series speed controller, as viewed into the control connector, is shown below. (H)

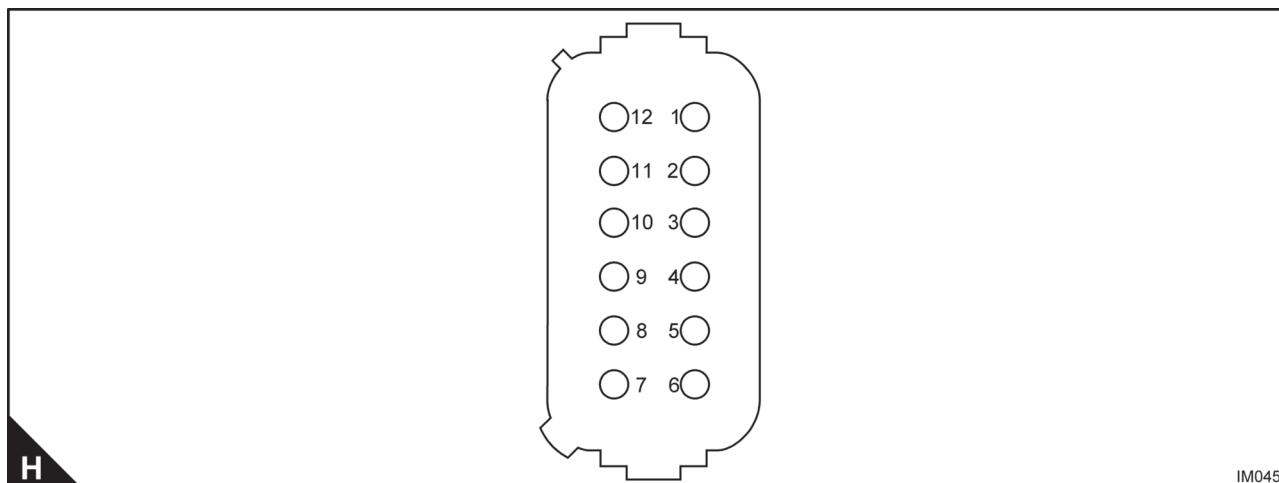

Connector pin#	Description	Comment
1	+12/24 VDC input power	Supply power - see note below
2	TPS signal output	Direct position feedback output indication
3	AUX - (sig gnd)	Ground for AUX inputs
4	Aux input 3 / RS-232 transmit	Combination Aux 3 and service tool input
5	Input power ground	Ground for the 12/24V input power
6	Aux input 4 / RS-232 receive	Combination Aux 4 and service tool input
7	5V out	Power for external sensors (10mA max)
8	Aux input 1	Aux 1 input
9	Relay driver output	Status / fault detection output
10	Aux input 2	Aux 2 input
11	MPU +	MPU speed signal input
12	Ignition input	Ignition speed signal input

Note: Power supply must be connected directly from the associated battery to pin 1 via a 5A fast acting fuse.

Other electrical features 6TG2AM

Wiring loom derived from document number 95-1034-3

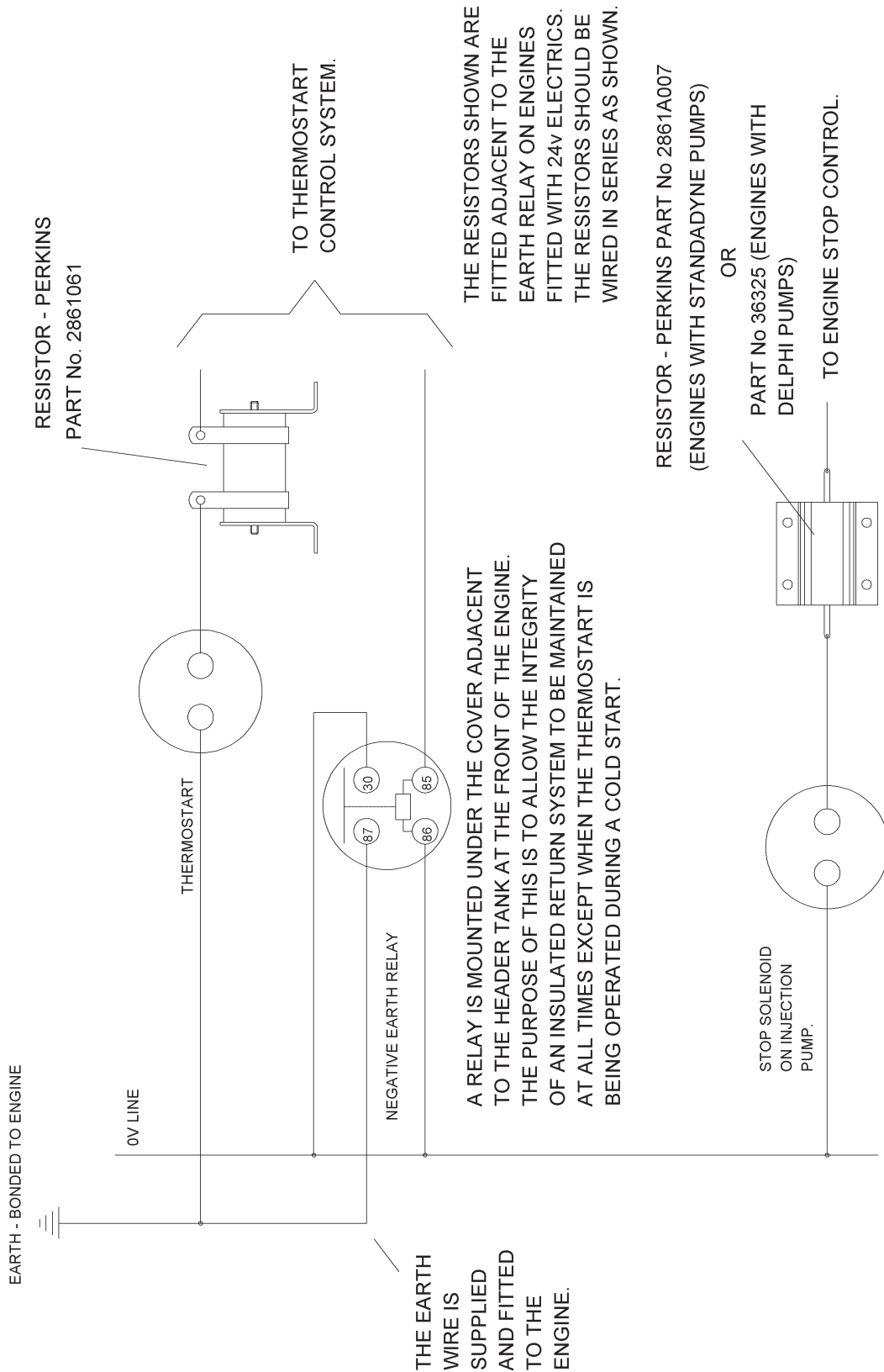

THE EARTH WIRE IS SUPPLIED AND FITTED TO THE ENGINE.

A RELAY IS MOUNTED UNDER THE COVER ADJACENT TO THE HEADER TANK AT THE FRONT OF THE ENGINE. THE PURPOSE OF THIS IS TO ALLOW THE INTEGRITY OF AN INSULATED RETURN SYSTEM TO BE MAINTAINED AT ALL TIMES EXCEPT WHEN THE THERMOSTART IS BEING OPERATED DURING A COLD START.

THE RESISTORS SHOWN ARE FITTED ADJACENT TO THE EARTH RELAY ON ENGINES FITTED WITH 24v ELECTRICS. THE RESISTORS SHOULD BE WIRED IN SERIES AS SHOWN.

RESISTOR - PERKINS PART No 2861A007 (ENGINES WITH STANDADYNE PUMPS)

OR

PART No 36325 (ENGINES WITH DELPHI PUMPS)

TO ENGINE STOP CONTROL.

Note: The engine speed controller is mechanical and contains the adjustment screws to set the engine speed for the 6TG2AM.

Other electrical features 6TWGM

Wiring loom derived from document number 98-1178-3

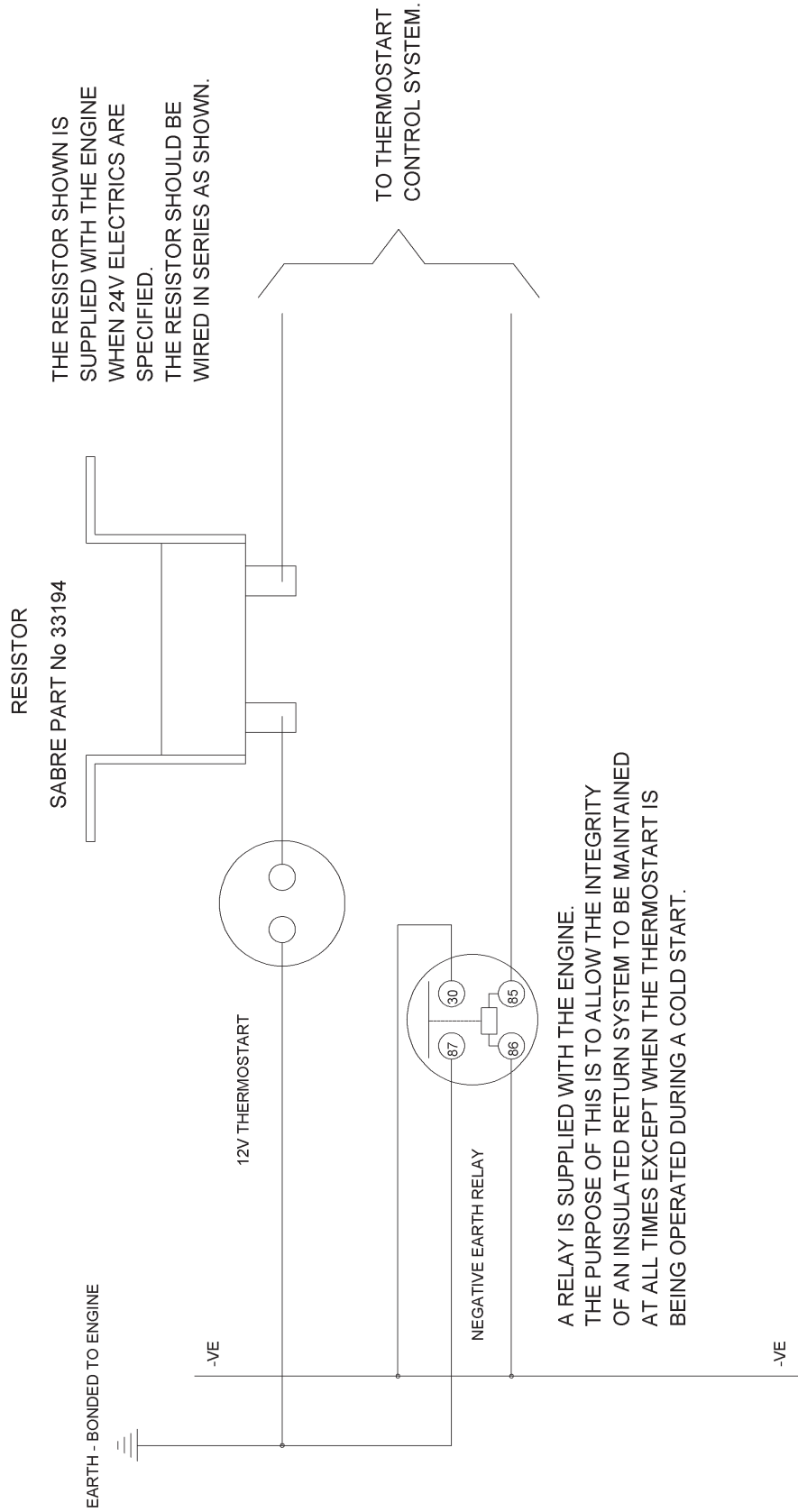

Electronic governor

To set the engine speed

1. Ensure that the speed control lever (I3) on the fuel injection pump is held in the fixed position and that adjustment screws are both locked.
2. Set the screw (I2) to position 30 on the dial.

Note: The settings on the dial are in increments of 10.

3. Turn the adjustment screw (I1) for the engine speed, in a counter-clockwise direction 20 complete turns. Then turn the screw in a clockwise direction 5 complete turns.
4. Start the engine and allow it to reach its normal temperature of operation. Initially, the engine speed will be low. To increase the speed of the engine, gradually turn the speed adjustment screw (I1) in a clockwise direction, until the correct engine speed is obtained.

Note: As load is applied to or removed from the engine, the engine speed will be electronically governed to within $\pm 0.25\%$. If this does not happen, further adjustments will be necessary.

5. If the time taken is too long for the engine to return to its correct speed, turn the adjustment screw (I2) gradually in a clockwise direction, to a position just above 30 on the dial.
6. Apply a load to the engine and check that the speed and governing are correct. If necessary, repeat operation 5.
7. If the time taken is too quick and the engine is erratic, turn the adjustment screw (I2) gradually in a counter-clockwise direction, to a position just below 30 on the dial.
8. Apply load to the engine and check that the speed and governing are correct. If necessary, repeat operation 7.

Note: It may be necessary to make further adjustments to the screws (I1) and (I2) until the correct speed and governing are obtained.

Caution: Any adjustments to these screws must be made gradually.

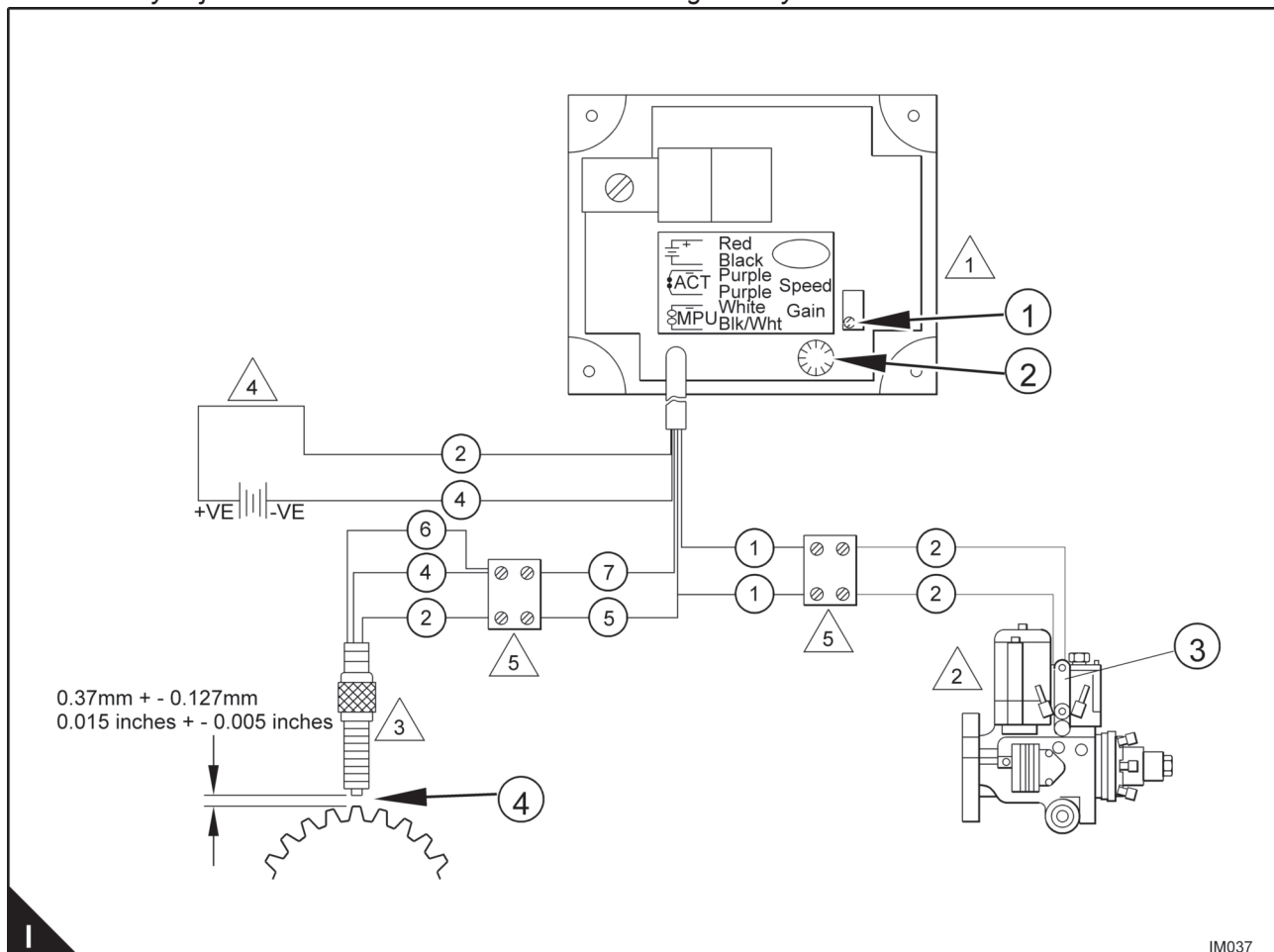

Identification of component numbers in triangles

Number	Description
1	Controller for engine speed
2	Actuator
3	Electro-magnetic sensor
4	Battery
5	Connector

Details for cables identified in circles

Circuit	Number	Colour
Controller to actuator	1	Purple
	2	Red
Controller to battery	2	Red
	4	Black
Controller to sensor	2	Red
	7	Black/white
	5	White
	6	Earth/Shield

Caution: The plastic connector that is supplied (loose) for the circuit 'controller to actuator', should be fitted with a crimping tool of the correct size. If it is not, the connector may be damaged.

6TWGM from March 2014

L Series electronic governor guidelines

A pinout of the L Series governor, as viewed into the control connector, is shown below (G). This information derived from document 5198-1-05.

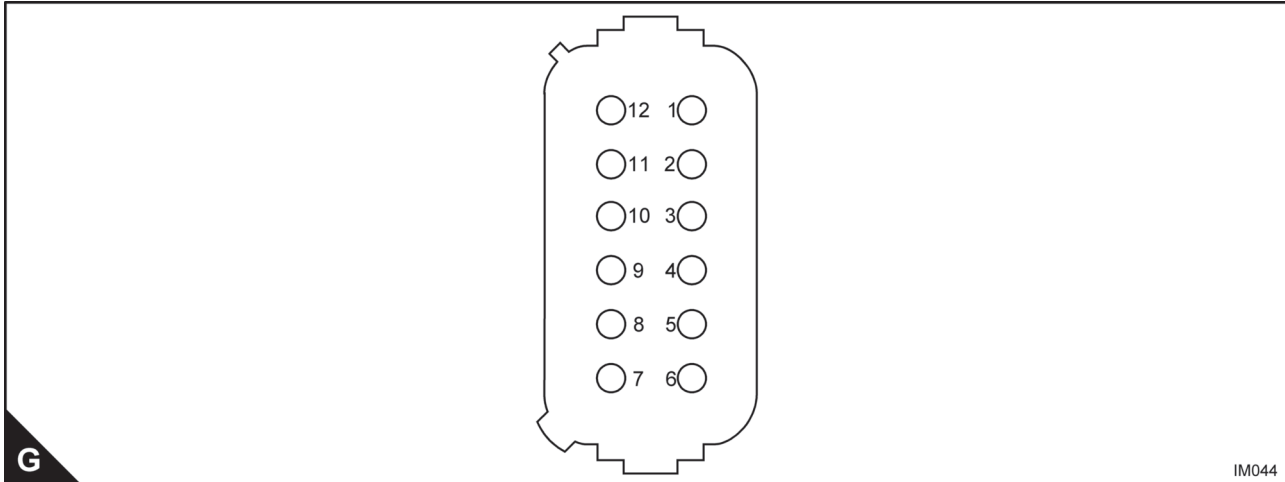

Connector pin#	Description	Comment
1	+12/24 VDC input power	Supply power
2	TPS signal output	Direct position feedback output indication
3	AUX - (sig gnd)	Ground for AUX inputs
4	Aux input 3 / RS-232 transmit	Combination Aux 3 and service tool input
5	Input power ground	Ground for the 12/24V input power
6	Aux input 4 / RS-232 receive	Combination Aux 4 and service tool input
7	5V out	Power for external sensors (10mA max)
8	Aux input 1	Aux 1 input
9	Relay driver output	Status / fault detection output
10	Aux input 2	Aux 2 input
11	MPU +	MPU speed signal input
12	Ignition input	Ignition speed signal input

Note: If any features are not required in the application, the related wiring may be omitted.

Data - 415GM

1500 rev/min 1800 rev/min

Basic Technical Data

Prime power, (mechanical).....	12.3kW (16.5 hp)	14.7kW (19.7hp)
Number of cylinders.....	3	
Cylinder arrangement.....	In-line	
Cycle.....	4 stroke	
Induction system.....	Naturally Aspirated	
Bore	84mm (3.31")	
Stroke	90mm (3.54")	
Compression ratio	22.5:1	
Cubic capacity	1496cc	
Valves per cylinder	2	
Direction of rotation	Anti-clockwise viewed on flywheel	
Firing order	1, 2, 3	
Total weight (wet).....	213kg (470lbs) engine only including starter and generator.	

Cooling System

The coolant shown below is mandatory for use in all climates to ensure that adequate levels of corrosion inhibitor are present. It will give frost protection to -37°C. (-34.6°F)

Coolant	50% inhibited ethylene glycol or 50% inhibited propylene glycol with 50% fresh clean water	
Fresh water flow	41 l/min (10.8 US galls/min) ...	49 l/min (12.9 US galls/min)
Coolant pump speed and method of drive.....	1.25:1 ratio, belt driven	
System capacity	8 litres (2.4 US galls)	
Pressure cap setting.....	50 kPa (7 psi)	
Protection switch setting.....	96°C (205°F)	
Sea water pump type.....	Jabsco gear driven model size 40	
Sea water suggested inlet hose diameter.....	25.4mm (1.00")	
Sea cock.....	Full flow 25.4mm (1.00") max lift of seawater pump 2m	
Strainer	A raw water strainer must be included in the suction side of the circuit.	
Maximum sea water temperature.....	38°C (100°F)	
Sea water flow	31.9 l/min (8.4 US galls/min) .	40.1 l/min (10.6 US galls/min)

Fuel System

Recommended fuel specifications.....	BS2869 Class A2 ASTM D 975 Number 2D.	
Cetane number.....	45 minimum.	
Fuel injection pump	Cassette type, inline pump with electronic governor	
Fuel lift pump	Mechanical	
Governor type.....	Electronic	

Pipe size:

- Supply - Outside diameter..... 7.9mm (0.315")
- Supply - Bore 6.53mm (0.257")
- Return - Outside diameter..... 6.3mm (0.25")
- Return - Bore..... 4.93mm (0.194")

Maximum lift pump lift (clean filter)..... 0.8m (2.6ft) To bottom of tank suction pipe

Maximum fuel lift pump depression at inlet. 127mm (5")Hg

Fuel consumption at full power. 3.7 l/hr (1.0 US galls/hr)4.5 l/hr (1.2 US galls/hr)

Air Intake

Combustion airflow 1.07m³/min (37.9 ft³/min) 1.26m³/min (44.4 ft³/min)

Maximum engine compartment air temperature.....60°C (140°F)

Maximum air temperature at engine inlet.52°C (126°F)

Ventilation - maximum engine
room depression..... 125mm H₂O (5in H₂O)

Minimum cross section
of air duct (per engine)65 cm²(10 sq ins) for hot climates.
..... 32 cm² (5 sq ins) for temperate climates.

Exhaust

Exhaust gas flow 2.75m³/min (97ft³/min) 3.37m³/min (119ft³/min)

Maximum restriction measured
within (305 mm) 12" outlet..... 10.13kPa (3.0" Hg)

Recommended pipe bore (wet exhaust)..... 50mm (2.0")

Recommended pipe bore (dry)..... 40mm (1.6")

Minimum rise from sea water level
to exhaust outlet centreline..... 203mm (8.0")

Lubricating System

Recommended lubricating oil. AP1 CH4 ACEA E5

Sump capacity maximum6 litres (1.5 US galls/min)

Normal operating angles 25° from horizontal in any direction

Oil pressure, in operating
speed range (steady state).....200kPa (29psi)

Low oil pressure switch setting.....80kPa (12psi)

Electrical System

Generator55A (12V)

Starter..... 12 volt 2.0 kW

Number of teeth in flywheel..... 109

Number of teeth on starter.....9

Cold Start Limits

Minimum cold start temperature (with aid). -15°C(5°F)

Batteries for min cold start..... 1 x 12 volt 540 amp SAE to BS3911
or 1 x 12 volt 740 amps to SAE J537

Data - 422GM

1500 rev/min 1800 rev/min

Basic Technical Data

Prime power, (mechanical) 18.4kW (24.7 hp) 22kW (29.5hp)
 Number of cylinders 4
 Cylinder arrangement In-line
 Cycle 4 stroke
 Induction system Naturally Aspirated
 Bore 84mm (3.31")
 Stroke 100mm (3.94")
 Compression ratio 23.3:1
 Cubic capacity 2216cc
 Valves per cylinder 2
 Direction of rotation Anti-clockwise viewed on flywheel
 Firing order 1, 3, 4, 2
 Total weight (wet) 277kg (611lbs) engine only including starter and generator.

Cooling System

The coolant shown below is mandatory for use in all climates to ensure that adequate levels of corrosion inhibitor are present. It will give frost protection to -37°C. (-34.6°F)

Coolant 50% inhibited ethylene glycol or 50% inhibited propylene glycol with 50% fresh clean water
 Fresh water flow 48 l/min (12.7 US galls/min) ... 56 l/min (14.8 US galls/min)
 Coolant pump speed and method of drive 1.25:1 ratio, belt driven
 System capacity 10.5 litres (2.4 US galls)
 Pressure cap setting 50kPa (7psi)
 Protection switch setting 96°C (205°F)
 Sea water pump type Jabsco gear driven model size 40
 Sea water suggested inlet hose diameter 25.4mm (1.00")
 Sea cock Full flow 25.4mm (1.00") max lift of seawater pump 2m
 Strainer A raw water strainer **must** be included in the suction side of the circuit.
 Maximum sea water temperature 38°C (100°F)
 Sea water flow 31.9 l/min (8.4 US galls/min) . 40.1 l/min (10.6 US galls/min)

Fuel System

Recommended fuel specifications BS2869 Class A2 ASTM D 975 Number 2D.
 Cetane number 45 minimum.
 Fuel injection pump Cassette type, inline pump with electronic governor
 Fuel lift pump Mechanical
 Governor type Electronic

Pipe size:

- Supply - Outside diameter..... 7.9mm (0.315")
- Supply - Bore 6.53mm (0.257")
- Return - Outside diameter 6.3mm (0.25")
- Return - Bore..... 4.93mm (0.194")

Maximum lift pump lift (clean filter).....0.8m (2.6ft) to bottom of tank suction pipe

Maximum fuel lift pump depression at inlet. 127mm (5") Hg

Fuel consumption at full power. 5.2 l/hr (1.4 US galls/hr)6.2 l/hr (1.6 US galls/hr)

Air Intake

Combustion airflow 1.46m³/min (51.5ft³/min)..... 1.76m³/min (62ft³/min)

Maximum engine compartment air temperature.....60°C (140°F)

Maximum air temperature at engine inlet.52°C (126°F)

Ventilation - maximum engine

room depression..... 125mm H₂O (5in H₂O)

Minimum cross section

of air duct (per engine)103cm²(16sq ins) for hot climates.

.....52cm² (8sq ins) for temperate climates.

Exhaust

Exhaust gas flow 3.51m³/min (124ft³/min) 4.45m³/min (157ft³/min)

Maximum restriction measured

within (305 mm) 12" outlet..... 10.13 kPa (3.0" Hg)

Recommended pipe bore (wet exhaust)..... 50mm (2.0")

Recommended pipe bore (dry)..... 40mm (1.6")

Minimum rise from sea water level

to exhaust outlet centreline..... 203mm (8.0")

Lubricating System

Recommended lubricating oil. AP1 CH4 ACEA E5

Sump capacity maximum 10.6 litres (2.7 US galls/min)

Normal operating angles25° continuously at all angles

Oil pressure, in operating

speed range (steady state).....200kPa (29psi)

Low oil pressure switch setting.....80kPa (12psi)

Electrical System

Generator55A (12V)

Starter..... 12 volt 2.0 kW

Number of teeth in flywheel..... 126

Number of teeth on starter.....9

Cold Start Limits

Minimum cold start temperature (with aid). -15°C(5°F)

Batteries for min cold start..... 1 x 12 volt 540 amps to BS3911

.....or 1 x 12 volt 740 amps to SAE J537

Data - 422TGM

1500 rev/min 1800 rev/min

Basic Technical Data

Prime power, (mechanical) 24.5kW (33.7hp) 30.3kW (40.6hp)
 Number of cylinders 4
 Cylinder arrangement In-line
 Cycle 4 stroke
 Induction system Turbocharged
 Bore 84mm (3.31")
 Stroke 100mm (3.94")
 Compression ratio 23.3:1
 Cubic capacity 2216cc
 Valves per cylinder 2
 Direction of rotation Anti-clockwise viewed on flywheel
 Firing order 1, 3, 4, 2
 Total weight (wet) 285kg (628lbs) engine only including starter and generator.

Cooling System

The coolant shown below is mandatory for use in all climates to ensure that adequate levels of corrosion inhibitor are present. It will give frost protection to -37°C. (-34.6°F)

Coolant 50% inhibited ethylene glycol or 50% inhibited propylene glycol with 50% fresh clean water
 Fresh water flow 48 l/min (12.7 US galls/min) ... 56 l/min (14.8 US galls/min)
 Coolant pump speed and method of drive 1.25:1 ratio, belt driven
 System capacity 10.5 litres (2.4 US galls)
 Pressure cap setting 50kPa (7psi)
 Protection switch setting 96°C (205°F)
 Sea water pump type Jabsco gear driven model size 40
 Sea water suggested inlet hose diameter 25.4mm (1.00")
 Sea cock Full flow 25.4mm (1.00") max lift of seawater pump 2m
 Strainer A raw water strainer must be included in the suction side of the circuit.
 Maximum sea water temperature 38°C (100°F)
 Sea water flow 31.9 l/min (8.4 US galls/min) . 40.1 l/min (10.6 US galls/min)

Fuel System

Recommended fuel specifications BS2869 Class A2 ASTM D 975 Number 2D.
 Cetane number 45 minimum.
 Fuel injection pump Cassette type, inline pump with electronic governor
 Fuel lift pump Mechanical
 Governor type Electronic

Pipe size:

- Supply - Outside diameter..... 7.9mm (0.315")
- Supply - Bore 6.53mm (0.257")
- Return - Outside diameter..... 6.3mm (0.25")
- Return - Bore..... 4.93mm (0.194")

Maximum lift pump lift (clean filter).....0.8m (2.6ft) to bottom of tank suction pipe

Maximum fuel lift pump depression at inlet. 127mm (5")Hg

Fuel consumption at full power. 5.2 l/hr (1.4 US galls/hr)6.2 l/hr (1.6 US galls/hr)

Air Intake

Combustion airflow1.46 m³/min (51.5ft³/min).....1.76m³/min (62 ft³/min)

Maximum engine compartment air temperature.....60°C (140°F)

Maximum air temperature at engine inlet.52°C (126°F)

Ventilation - maximum engine

room depression.....125mm H₂O (5 in H₂O)

Minimum cross section

of air duct (per engine) 103cm² (16sq ins) for hot climates.

.....52cm² (8sq ins) for temperate climates.

Exhaust

Exhaust gas flow 4.13m³/min (146ft³/min) 5.01m³/min (177ft³/min)

Maximum restriction measured

within (305 mm) 12" outlet.....10.21kPa (3.0" Hg)

Recommended pipe bore (wet exhaust)..... 63.5mm (2.5")

Recommended pipe bore (dry)..... 50mm (2.0")

Minimum rise from sea water level

to exhaust outlet centreline..... 203mm (8.0")

Lubricating System

Recommended lubricating oil. AP1 CH4 ACEA E5

Sump capacity maximum 10.6 litres (2.7 US galls/min)

Normal operating angles25° continuously at all angles

Oil pressure, in operating

speed range (steady state).....200kPa (29psi)

Low oil pressure switch setting.....80kPa (12psi)

Electrical System

Generator55A (12V)

Starter..... 12 volt 2.0 kW

Number of teeth in flywheel.....126

Number of teeth on starter.....9

Cold Start Limits

Minimum cold start temperature (with aid). -15°C(5°F)

Batteries for min cold start..... 1 x 12 volt 540 Amp to BS3911

.....or 1 x 12 volt 740 amps to SAE J537

Data - 700GM

1500 rev/min 1800 rev/min

Basic Technical Data

Prime power	27.2kW (36.5 hp)	31.8kW (42.7 hp)
Number of cylinders.....	4	
Cylinder arrangement.....	In-line	
Cycle.....	4 stroke	
Induction system.....	Naturally Aspirated	
Bore	97mm (3.82")	
Stroke	100mm (3.94")	
Compression ratio	17.5:1	
Cubic capacity	3.0 litres (183in ³)	
Valves per cylinder	2	
Direction of rotation	Anti-clockwise viewed on flywheel	
Firing order	1, 3, 4, 2	
Total weight (wet).....	282kg (622 lbs) engine only including starter and generator.	

Cooling System

The coolant shown below is mandatory for use in all climates to ensure that adequate levels of corrosion inhibitor are present. It will give frost protection to -37°C. (-34.6°F)

Coolant	50% inhibited ethylene glycol or 50% inhibited propylene glycol with 50% fresh clean water	
Fresh water flow	80 l/min (21 US galls/min)	97 l/min (25.6 US galls/min)
Coolant pump speed and method of drive.....	1.25:1 ratio, belt driven	
System capacity	8.75 litres (2.31 US galls)	
Pressure cap setting.....	50kPa (7 psi)	
Protection switch setting.....	96°C (205°F)	
Sea water pump type.....	Jabsco gear driven model 19mm (0.75") 3/4 cam.	
Sea water suggested inlet hose diameter.....	32mm (1.25")	
Sea cock.....	Full flow 25.4mm (1.00") max lift of seawater pump 2m Full flow 38.1mm (1.25") max lift of seawater pump 4m	
Strainer	A raw water strainer must be included in the suction side of the circuit.	
Maximum sea water temperature.....	38°C (100°F)	
Sea water flow	53 l/min (14 US galls/min)	69 l/min (18 US galls/min)

Fuel System

Recommended fuel specifications.....	BS2869 Class A2 ASTM D 975 Number 2D.	
Cetane number.....	45 minimum.	
Fuel injection pump	Zexel PTR, inline pump with electronic governor	
Fuel lift pump.....	FCM type XY - lever operated diaphragm pump	
Pressure	42 - 70 kPa (6.1 - 10.2 lbf/in ²)	
Governor type.....	Electronic	

Pipe size:

- Supply - Outside diameter..... 7.9 mm (0.315")
- Supply - Bore 6.53 mm (0.257")
- Return - Outside diameter..... 6.3 mm (0.25")
- Return - Bore..... 4.93 mm (0.194")

Maximum lift pump lift..... 1.53 m (5 ft) to bottom of tank suction pipe.

Maximum fuel lift pump depression at inlet. 120 mm (4.72") Hg

Fuel consumption at full power. 6.7 l/hr (1.8 US galls/hr) 7.4 l/hr (2.0 US galls/hr)

Air Intake

Combustion airflow 1.8 m³/min (65 ft³/min)..... 2.2 m³/min (77 ft³/min)

Maximum engine compartment air temperature..... 60°C (140°F)

Maximum air temperature at engine inlet. 52°C (126°F)

Ventilation - maximum engine
room depression..... 125mm H₂O (5 in H₂O)

Minimum cross section
of air duct (per engine) 135 cm²(21 sq ins) for hot climates.
..... 71 cm² (11 sq ins) for temperate climates.

Exhaust

Exhaust gas flow 5.0 m³/min (175 ft³/min) 5.75 m³/min (203 ft³/min)

Maximum restriction measured
within (305 mm) 12" outlet..... 10.2 kPa (3.0" Hg)

Recommended pipe bore (wet exhaust)..... 63.5 mm (2.5")

Recommended pipe bore (dry)..... 40 mm (1.6")

Minimum rise from sea water level
to exhaust outlet centreline..... 203 mm (8.0")

Lubricating System

Recommended lubricating oil.AP1 CD/SE CCMC D4

Sump capacity maximum 15 litres (4 US galls/min)

Normal operating angles 25° from horizontal in any direction

Oil pressure, in operating
speed range (steady state)..... 310 to 390 kPa (45 to 57 psi)

Low oil pressure switch setting..... 83kPa (12 psi)

Electrical System

Generator 70A (12V)

Starter type Magneti Marelli 12V 2.5 kW

Number of teeth in flywheel..... 126

Number of teeth on starter..... 10

Cold Start Limits

Minimum cold start temperature (with aid). -15°C(5°F)

Batteries for min cold start..... 1 x 12 volt 540 Amp SAE (340 Amp IEC)

Data - 4GM

1500 rev/min 1800 rev/min

Basic Technical Data

Prime power	39.5kW (53 hp).....	46.5kW (62.3 hp)
Number of cylinders.....	4	
Cylinder arrangement.....	In-line	
Cycle.....	4 stroke	
Induction system.....	Naturally Aspirated	
Bore	100 mm (3.937")	
Stroke	127 mm (5.00")	
Compression ratio	16:1	
Cubic capacity	3.99 litres (243.0 in ³)	
Valves per cylinder	2	
Direction of rotation	Anti-clockwise viewed on flywheel	
Firing order	1, 3, 4, 2	
Total weight (wet).....	449 kg (990 lbs) engine only including starter and generator.	

Cooling System

The coolant shown below is mandatory for use in all climates to ensure that adequate levels of corrosion inhibitor are present. It will give frost protection to -37°C. (-34.6°F)

Coolant	50% inhibited ethylene glycol or 50% inhibited propylene glycol with 50% fresh clean water	
Fresh water flow	80 l/min (21 US galls/min)	97 l/min (25.6 US galls/min)
Coolant pump speed and method of drive.....	1.25:1 ratio, belt driven	
System capacity	18 litres (4.8 US galls)	
Pressure cap setting.....	50 kPa (7 psi)	
Protection switch setting.....	96°C (205°F)	
Sea water pump type.....	Jabsco gear driven model 25.4 mm (1") full cam.	
Sea water suggested inlet hose diameter.....	32 mm (1.25")	
Sea cock.....	Full flow 25.4mm (1.00") max lift of seawater pump 2m Full flow 38.1mm (1.25") max lift of seawater pump 4m	
Strainer	A raw water strainer must be included in the suction side of the circuit.	
Maximum sea water temperature.....	38°C (100°F)	
Sea water flow	73 l/min (19 US galls/min)	91 l/min (24 US galls/min)

Fuel System

Recommended fuel specifications.....	BS2869 Class A2 ASTM D 975 Number 2D.	
Cetane number.....	45 minimum.	
Fuel injection pump	Stanadyne rotary and electric stop. (Energised to run).	
Fuel lift pump	AC Delco type LU	
Delivery/hour	89 l/hr (23.5 US galls/min)	98 l/hr (25.9 US galls/min)
Pressure	30 kPa (4.4 PSI)	
Governor type.....	Mechanical	

Pipe size:

- Supply - Outside diameter..... 7.9 mm (0.315")
- Supply - Bore 6.53 mm (0.257")
- Return - Outside diameter..... 6.3 mm (0.25")
- Return - Bore..... 4.93 mm (0.194")

Maximum lift pump lift..... 1.8m (6 ft) to bottom of tank suction pipe.

Maximum fuel lift pump depression at inlet. 127 mm (5") Hg

Fuel consumption at full power. 9.4 l/hr (2.5 US galls/hr) 13.6 l/hr (3.6 US galls/hr)

Air Intake

Combustion airflow 2.64m³/min (93 ft³/min)..... 3.19m³/min (112 ft³/min)

Maximum engine compartment air temperature..... 60°C (140°F)

Maximum air temperature at engine inlet. 52°C (126°F)

Ventilation - maximum engine room depression..... 125mm H₂O (5 in H₂O)

Suggested ventilation airflow including combustion air. 18.6m³/min (657ft³/in)

Minimum cross section of air duct (per engine) 200 cm²(31 sq ins) for hot climates.
..... 103 cm² (16 sq ins) for temperate climates.

Exhaust

Exhaust gas flow 7.54 m³/min (266 ft³/min) 9.09 m³/min (321 ft³/min)

Maximum restriction measured within (305 mm) 12" outlet..... 6 kPa (1.76" Hg)

Recommended pipe bore (wet exhaust)..... 76.2mm (3.0")

Recommended pipe bore (dry)..... 60mm (2.36")

Minimum rise from sea water level to exhaust outlet centreline..... 203mm (8.0")

Lubricating System

Recommended lubricating oil.AP1 CD/SE CCMC D4

Sump capacity maximum 15 litres (4 US galls/min)

Normal operating angles 25° from horizontal in any direction

Oil pressure, in operating speed range (steady state)..... 310 to 390kPa (45 to 57psi)

Low oil pressure switch setting..... 83kPa (12 psi)

Electrical System

Generator Prestolite AS128 90A (24V) or 55A (12V)

Starter type.....Prestolite S115

Number of teeth in flywheel..... 126

Number of teeth on starter..... 10

Cold Start Limits

Minimum cold start temperature (with aid).-15C(5F)

Batteries for min cold starta qty of 2 12V 315 Amps to BS3911 or 2 off - 12V, 535 amps to SAE J537

Data - 4TGM

1500 rev/min 1800 rev/min

Basic Technical Data

Prime power	68.5kW (91.9hp).....	80.5kW (108hp)
Number of cylinders.....	4	
Cylinder arrangement.....	In-line	
Cycle.....	4 stroke	
Induction system.....	Turbocharged	
Bore	100mm (3.937")	
Stroke	127mm (5.00")	
Compression ratio	16:1	
Cubic capacity	3.99 litres (243 in ³)	
Valves per cylinder	2	
Direction of rotation	Anti-clockwise viewed on flywheel	
Firing order	1, 3, 4, 2	
Total weight (wet).....	456kg (1005lbs) engine only including starter and generator.	

Cooling System

The coolant shown below is mandatory for use in all climates to ensure that adequate levels of corrosion inhibitor are present. It will give frost protection to -37°C (-34.6°F).

Coolant	50% inhibited ethylene glycol or 50% inhibited propylene glycol with 50% fresh clean water	
Fresh water flow	80 l/min (21 US galls/min)	97 l/min (25.6 US galls/min)
Coolant pump speed and method of drive.....	1:1 Gear driven	
System capacity	18 litres (4.8 US galls)	
Pressure cap setting.....	50kPa (7psi)	
Protection switch setting.....	96°C (205°F)	
Sea water pump type.....	Jabsco gear driven model 25.4 mm (1") full cam.	
Sea water suggested inlet hose diameter.....	32mm (1.25")	
Sea cock.....	Full flow 25.4mm (1.00") max lift of seawater pump 2m Full flow 38.1mm (1.25") max lift of seawater pump 4m	
Strainer	A raw water strainer must be included in the suction side of the circuit.	
Maximum sea water temperature.....	38°C (100°F)	
Sea water flow	73 l/min (19 galls/min)	91 l/min (24 US galls/min)

Fuel System

Recommended fuel specifications.....	BS2869 Class A2 ASTM D 975 Number 2D.	
Cetane number.....	45 minimum	
Fuel injection pump	Stanadyne rotary and electric stop. (Energised to run).	
Fuel lift pump.....	AC Delco type LU	
Delivery.....	89 l/hr (23.5 US galls/hr)	98 l/hr (25.9 US galls/min)
Pressure	30kPa (4.4 PSI)	
Governor type.....	Mechanical	

Pipe size:

- Supply - Outside diameter..... 7.9mm (0.315")
- Supply - Bore 6.53mm (0.257")
- Return - Outside diameter..... 6.3mm (0.25")
- Return - Bore..... 4.93mm (0.194")

Maximum lift pump lift.....1.8m (6ft) to bottom of tank suction pipe.

Maximum fuel lift pump depression at inlet. 127mm (5")Hg

Fuel consumption at full power. 17.1 l/hr (4.5 US galls/hr) 19.9 l/hr (5.3 US galls/hr)

Air Intake

Combustion airflow.....4.52m³/min (159 ft³/min)..... 5.85m³/min (206 ft³/min)

Maximum engine compartment air temperature..... 60°C (140°F)

Maximum air temperature at engine inlet. 52°C (126°F)

Ventilation - maximum engine room depression.....125mm H₂O (5 in H₂O)

Suggested ventilation airflow

including combustion air. 31m³/min (1095 ft³/min)

Minimum cross section of

air duct (per engine) 348cm² (54sq ins) for hot climates.

..... 174cm² (27sq ins) for temperate climates.

Exhaust

Exhaust gas flow 13.1m³/min (462 ft³/min)..... 15.9m³/min (561 ft³/min)

Maximum restriction measured

within(305 mm) 12" outlet..... 6kPa (1.76" Hg)

Recommended pipe bore (wet exhaust)..... 76.2mm (3.0")

Recommended pipe bore (dry)..... 60mm (2.36")

Minimum rise from sea water level to

exhaust outlet centreline..... 203mm (8.0")

Lubricating System

Recommended lubricating oil.AP1 CD/SE CCMC D4

Sump capacity maximum15 litres (4 US gallons)

Normal operating angles 25° from horizontal in any direction

Oil pressure, in operating

speed range (steady state).....310 to 390 kPa (45 to 57 psi)

Low oil pressure switch setting..... 83kPa (12 psi)

Electrical System

Generator Prestolite AS128 90A (12V) or 55A (24V)

Starter type.....Prestolite S115

Number of teeth in flywheel..... 126

Number of teeth on starter..... 10

Cold Start Limits

Minimum cold start temperature (with aid). -15°C (5°F)

Batteries for min cold starta qty of 2 off 12V 315 Amps to BS3911 or 2 off - 12V, 535 amps to SAE J537

Data - 4.4GM

1500 rev/min 1800 rev/min

Basic Technical Data

Prime power, (mechanical).....	42.7kW (57.3 hp)	49.1kW (65.8 hp)
Number of cylinders.....	4		
Cylinder arrangement.....	In-line		
Cycle.....	4 stroke		
Induction system.....	Naturally Aspirated		
Bore.....	100mm (3.937")		
Stroke.....	127mm (5.00")		
Compression ratio.....	18.23:1		
Cubic capacity.....	4.4 litres		
Valves per cylinder.....	2		
Direction of rotation.....	Anti-clockwise viewed on flywheel		
Firing order.....	1, 3, 4, 2		
Total weight (dry).....	489kg (1078lbs) engine only including starter and generator.		

Cooling System

The coolant shown below is mandatory for use in all climates to ensure that adequate levels of corrosion inhibitor are present. It will give frost protection to -37°C. (-34.6°F)

Coolant.....	50% inhibited ethylene glycol or 50% inhibited propylene glycol with 50% fresh clean water		
Fresh water flow.....	100 l/min (26.4 US galls/min)..	116 l/min (30.6 US galls/min)
Coolant pump speed and method of drive.....	Gear driven		
System capacity.....	16.5 litres (4.4 US galls)		
Pressure cap setting.....	50kPa (7 psi)		
Protection switch setting.....	96°C (205°F)		
Sea water pump type.....	Jabsco gear driven model size 25.4mm (1")		
Sea water suggested inlet hose diameter.....	32mm (1.25")		
Sea cock.....	Full flow 25.4mm (1.00") max lift of seawater pump 2m		
.....	Full flow 38.1mm (1.50") max lift of seawater pump 4m		
Strainer.....	A raw water strainer must be included in the suction side of the circuit.		
Maximum sea water temperature.....	38°C (100°F)		
Sea water flow.....	86 l/min (22.7 US galls/min)...	102 l/min (26.9 US galls/min)

Fuel System

Recommended fuel specifications.....	BS2869 Class A2 ASTM D 975 Number 2D.		
Cetane number.....	45 minimum.		
Fuel injection pump.....	Delphi rotary		
Fuel lift pump.....	Electric		
Pressure.....	30 - 75kPa (4.4 - 10.9 PSI)		
Delivery/hr.....	120 - 150 ltr/hr (31.7 US galls/hr to 39.6 US galls/hr)		
Governor type.....	L Series, electronic governor		

Pipe size:

- Supply - Outside diameter..... 7.9mm (0.315")
- Supply - Bore 6.53mm (0.257")
- Return - Outside diameter..... 6.3mm (0.25")
- Return - Bore..... 4.93mm (0.194")

Maximum lift pump lift (clean filter)..... 17kPa at 1.7m using 8mm dia. bore pipe

Maximum fuel lift pump depression at inlet. 127mm (5") Hg

Fuel consumption at full power. 12.2 l/hr (3.2 US galls/hr) 14.5 l/hr (3.8 US galls/hr)

Air Intake

Combustion airflow 3.19m³/min (113 ft³/min)..... 3.58m³/min (126 ft³/min)

Maximum engine compartment air temperature..... 60°C (140°F)

Maximum air temperature at engine inlet. 52°C (126°F)

Ventilation - maximum engine room depression..... 125mm H₂O (5 in H₂O)

Minimum cross section of air duct (per engine) 232 cm²(36 sq ins) for hot climates.
..... 116 cm² (18 sq ins) for temperate climates.

Exhaust

Exhaust gas flow 7.6m³/min (268 ft³/min)..... 8.8m³/min (311 ft³/min)

Maximum restriction measured within (305 mm) 12" outlet..... 15kPa (4.4" Hg)

Recommended pipe bore (wet exhaust)..... 76mm (3.0")

Recommended pipe bore (dry)..... 57mm (2.25")

Minimum rise from sea water level to exhaust outlet centreline..... 203mm (8.0")

Lubricating System

Recommended lubricating oil. AP1 CG4/CH4 ACEA E3/E5

Sump capacity maximum 8.5 litres (2.2 US galls/min)

Normal operating angles 25° from horizontal in any direction

Oil pressure, in operating speed range (steady state)..... 250kPa (36 psi)

Low oil pressure switch setting..... 83kPa (12 psi)

Electrical System

Generator 100A (12V), 55A (24V)

Starter..... 12 volt 4.0 kW

Number of teeth in flywheel..... 126

Number of teeth on starter..... 9

Cold Start Limits

Minimum cold start temperature (with aid). -15°C(5°F)

Batteries for min cold start..... 1 x 12 volt 660 Amp SAE

Data - 4.4TGM

1500 rev/min 1800 rev/min

Basic Technical Data

Prime power (mechanical).....	56.4 kW (75.6 hp).....	63.6 kW (85.3 hp)
Number of cylinders.....	4	
Cylinder arrangement.....	In-line	
Cycle.....	4 stroke	
Induction system.....	Turbocharged	
Bore.....	100mm (3.937")	
Stroke.....	127mm (5.00")	
Compression ratio.....	19.3:1	
Cubic capacity.....	4.4 litres	
Valves per cylinder.....	2	
Direction of rotation.....	Anti-clockwise viewed on flywheel	
Firing order.....	1, 3, 4, 2	
Total weight (wet).....	505kg (1113 lbs) engine only including starter and generator.	

Cooling System

The coolant shown below is mandatory for use in all climates to ensure that adequate levels of corrosion inhibitor are present. It will give frost protection to -37°C. (-34.6°F)

Coolant.....	50% inhibited ethylene glycol or 50% inhibited propylene glycol with 50% fresh clean water	
Fresh water flow.....	145 l/min (37.3 US galls/min)...	171 l/min (45.2 US galls/min)
Coolant pump speed and method of drive.....	Gear driven	
System capacity.....	16.5 litres (4.4 US galls)	
Pressure cap setting.....	50kPa (7 psi)	
Protection switch setting.....	96°C (205°F)	
Sea water pump type.....	Jabsco gear driven model 25.4 (1")	
Sea water suggested inlet hose diameter.....	32mm (1.25")	
Sea cock.....	Full flow 25.4mm (1.00") max lift of seawater pump 2m	
	Full flow 38.1mm (1.25") max lift of seawater pump 4m	
Strainer.....	A raw water strainer must be included in the suction side of the circuit.	
Maximum sea water temperature.....	38°C (100°F)	
Sea water flow.....	86 l/min (22.7 US galls/min)...	102 l/min (26.9 US galls/min)

Fuel System

Recommended fuel specifications.....	BS2869 Class A2 ASTM D 975 Number 2D.	
Cetane number.....	45 minimum.	
Fuel injection pump.....	Delphi rotary	
Fuel lift pump.....	Electric	
Delivery/hr.....	120 - 150 ltr/hr (31.7 US galls/hr to 39.6 US galls/hr)	
	30 - 75 kPa (4.4 - 10.9 PSI)	
Governor type.....	L series electronic governor	

Pipe size:

- Supply - Outside diameter..... 7.9mm (0.315")
- Supply - Bore 6.53mm (0.257")
- Return - Outside diameter..... 6.3mm (0.25")
- Return - Bore..... 4.93mm (0.194")

Maximum lift pump lift (clean filter)..... 17kPa at 1.7m using 8mm dia. bore pipe.

Maximum fuel lift pump depression at inlet. 127mm (5.00") Hg

Fuel consumption at full power. 14.8 l/hr (3.9 US galls/hr) 16.9 l/hr (4.5 US galls/hr)

Air Intake

Combustion airflow 5.0 m³/min (177 ft³/min) 5.97 m³/min (211 ft³/min)

Maximum engine compartment air temperature..... 60°C (140°F)

Maximum air temperature at engine inlet. 52°C (126°F)

Ventilation - maximum engine
room depression..... 125mm H₂O (5 in H₂O)

Minimum cross section
of air duct (per engine) 302cm² (47sq ins) for hot climates.
..... 159cm² (24.7sq ins) for temperate climates.

Exhaust

Exhaust gas flow 10.1m³/min (357 ft³/min)..... 13.0m³/min (459 ft³/min)

Maximum restriction measured
within (305 mm) 12" outlet..... 15kPa (4.4" Hg)

Recommended pipe bore (wet exhaust)..... 76.2mm (3.0")

Recommended pipe bore (dry)..... 57mm (2.24")

Minimum rise from sea water level
to exhaust outlet centreline..... 203mm (8.0")

Lubricating System

Recommended lubricating oil. AP1 CG4/CH4 or ACEA E3/E5

Sump capacity maximum 8.5 litres (2.2 US galls/min)

Normal operating angles 25° from horizontal in any direction

Oil pressure, in operating
speed range (steady state)..... 250kPa (36 psi)

Low oil pressure switch setting..... 83kPa (12 psi)

Electrical System

Generator 100A (12V), 55A (24V)

Starter type 12V 4.0kW

Number of teeth in flywheel..... 126

Number of teeth on starter..... 10

Cold Start Limits

Minimum cold start temperature (with aid). -15°C(5°F)

Batteries for min cold start..... 1 x 12 volt 660 Amp SAE

Data - 4.4TWGM

1500 rev/min 1800 rev/min

Basic Technical Data

Prime power (mechanical)..... 75kW (101 hp) 82.7kW (111 hp)
 Number of cylinders..... 4
 Cylinder arrangement..... In-line
 Cycle..... 4 stroke
 Induction system..... Turbocharged, aftercooled
 Bore 100mm (3.937")
 Stroke 127mm (5.00")
 Compression ratio 19.3:1
 Cubic capacity 4.4 litres (19.3 in³)
 Valves per cylinder 2
 Direction of rotation Anti-clockwise viewed on flywheel
 Firing order 1, 3, 4, 2
 Total weight (wet)..... 522kg (1151 lbs) engine only including starter and generator.

Cooling System

The coolant shown below is mandatory for use in all climates to ensure that adequate levels of corrosion inhibitor are present. It will give frost protection to -37°C. (-34.6°F)

Coolant 50% inhibited ethylene glycol or 50% inhibited propylene glycol with 50% fresh clean water
 Fresh water flow 145 l/min (37.3 US galls/min).. 171 l/min (45.2 US galls/min)
 Coolant pump speed and method of drive..... 1:1 Gear driven
 System capacity 16.5 litres (4.4 US galls)
 Pressure cap setting..... 50kPa (7 psi)
 Protection switch setting..... 96°C (205°F)
 Sea water pump type..... Jabsco gear driven model 25.4mm
 Sea water suggested inlet hose diameter..... 32mm (1.25")
 Sea cock..... Full flow 25.4mm (1.00") max lift of seawater pump 2m
 Full flow 38.1mm (1.25") max lift of seawater pump 4m
 Strainer A raw water strainer must be included in the suction side of the circuit.
 Maximum sea water temperature..... 38°C (100°F)
 Sea water flow 86 l/min (22.7 US galls/min)... 102 l/min (26.9 US galls/min)

Fuel System

Recommended fuel specifications..... BS2869 Class A2 ASTM D 975 Number 2D.
 Cetane number..... 45 minimum.
 Fuel injection pump Delphi rotary
 Fuel lift pump Electric
 Delivery/hour 120 - 150 l/hr (31.7 US galls/hr to 39.6 US galls/hr)
 Pressure 30 - 75kPa (4.4 - 10.9 PSI)
 Governor type..... L series electronic governor

Pipe size:

- Supply - Outside diameter 7.9mm (0.315")
- Supply - Bore 6.53mm (0.257")
- Return - Outside diameter 6.3mm (0.25")
- Return - Bore 4.93mm (0.194")

Maximum lift pump lift (clean filter) 17kPa at 1.7m using 8mm dia. bore pipe

Maximum fuel lift pump depression at inlet. 127mm (5") Hg

Fuel consumption at full power. 18.6 l/hr (4.9 US galls/hr) 22 l/hr (5.8 US galls/hr)

Air Intake

Combustion airflow 7.3 m³/min (258 ft³/min) 9.4 m³/min (332 ft³/min)

Maximum engine compartment air temperature 60°C (140°F)

Maximum air temperature at engine inlet. 52°C (126°F)

Ventilation - maximum engine room depression 125mm H₂O (5 in H₂O)

Minimum cross section of air duct (per engine) 358cm² (55.5sq ins) for hot climates.
 81cm² (28sq ins) for temperate climates.

Exhaust

Exhaust gas flow 17.7m³/min (625 ft³/min) 21.2m³/min (749 ft³/min)

Maximum restriction measured within (305 mm) 12" outlet 15kPa (4.4" Hg)

Recommended pipe bore (wet exhaust) 100mm (4.0")

Recommended pipe bore (dry) 76.2mm (3.0")

Minimum rise from sea water level to exhaust outlet centreline 203mm (8.0")

Lubricating System

Recommended lubricating oil. AP1 CG4/CH4 or ACEA E3/E5

Sump capacity maximum 15 litres (4 US galls/min)

Normal operating angles 25° from horizontal in any direction

Oil pressure, in operating speed range (steady state) 250kPa (36 psi)

Low oil pressure switch setting 83kPa (12 psi)

Electrical System

Generator 100A (12V), 55A (24V)

Starter type 12 V 4.0 kW

Number of teeth in flywheel 126

Number of teeth on starter 10

Cold Start Limits

Minimum cold start temperature (with aid). -15°C(5°F)

Batteries for min cold start 1 x 12 volt 660 amp SAE

Data - 4.4TW2GM

1500 rev/min 1800 rev/min

Basic Technical Data

Prime power	93.6kW (125.3 hp)	106.8kW (143 hp)
Number of cylinders.....	4	
Cylinder arrangement.....	In-line	
Cycle.....	4 stroke	
Induction system.....	Turbocharged/Aftercooled	
Bore	100mm (3.937")	
Stroke	127mm (5.00")	
Compression ratio	19.3:1	
Cubic capacity	3.99 litres (243 in ³)	
Valves per cylinder	2	
Direction of rotation	Anti-clockwise viewed on flywheel	
Firing order	1, 3, 4, 2	
Total weight (wet).....	522kg (1151 lbs) engine only including starter and generator.	

Cooling System

The coolant shown below is mandatory for use in all climates to ensure that adequate levels of corrosion inhibitor are present. It will give frost protection to -37°C (-34.6°F).

Coolant	50% inhibited ethylene glycol or 50% inhibited propylene glycol with 50% fresh clean water	
Fresh water flow	145 l/min (37.3 US galls/min) ..	171 l/min (45.2 US galls/min)
Coolant pump speed and method of drive.....	1:1 Gear driven	
System capacity	16.5 litres (4.8 US galls)	
Pressure cap setting.....	50kPa (7 psi)	
Protection switch setting.....	96°C (205°F)	
Sea water pump type.....	Jabsco gear driven model 25.4mm (1") full cam.	
Sea water suggested inlet hose diameter.....	32mm (1.25")	
Sea cock.....	Full flow 25.4mm (1.00") max lift of seawater pump 2m	
	Full flow 38.1mm (1.25") max lift of seawater pump 4m	
Strainer	A raw water strainer must be included in the suction side of the circuit.	
Maximum sea water temperature.....	38°C (100°F)	
Sea water flow	86 l/min (22.7 US galls/min) ...	102 l/min (26.9 US galls/min)

Fuel System

Recommended fuel specifications.....	BS2869 Class A2 ASTM D 975 Number 2D.	
Cetane number.....	45 minimum	
Fuel injection pump	Delphi rotary	
Fuel lift pump.....	Electric	
Delivery.....	120-150l/hr (31.7 US galls/hr to 39.6 US galls/hr)	
Pressure	30-75kPa (4.4-10.9 PSI)	
Governor type.....	L series electronic governor	

Pipe size:

- Supply - Outside diameter..... 7.9mm (0.315")
- Supply - Bore 6.53mm (0.257")
- Return - Outside diameter 6.3mm (0.25")
- Return - Bore..... 4.93mm (0.194")

Maximum lift pump lift..... 1.8m (6 ft) to bottom of tank suction pipe.

Maximum fuel lift pump depression at inlet. 127mm (5") Hg

Fuel consumption at full power. 24.6 l/hr (6.5 US galls/hr)27.7 l/hr (7.3 US galls/hr)

Air Intake

Combustion airflow 7.9m³/min (279 ft³/min)..... 9.9m³/min (350 ft³/min)

Maximum engine compartment air temperature..... 60°C (140°F)

Maximum air temperature at engine inlet. 52°C (126°F)

Ventilation - maximum engine room depression..... 125mm H₂O (5 in H₂O)

Suggested ventilation airflow

including combustion air. 31m³/min (1095 ft³/min)

Minimum cross section of

air duct (per engine) 461 cm² (71.5 sq ins) for hot climates.

..... 231 cm² (35.8 sq ins) for temperate climates.

Exhaust

Exhaust gas flow 19.5m³/min (689 ft³/min)..... 24.3m³/min (858 ft³/min)

Maximum restriction measured

within(305 mm) 12" outlet..... 15kPa (4.4" Hg)

Recommended pipe bore (wet exhaust)..... 100mm (4.0")

Recommended pipe bore (dry)..... 76.2mm (3.0")

Minimum rise from sea water level to

exhaust outlet centreline..... 203mm (8.0")

Lubricating System

Recommended lubricating oil.AP1 CD/SE CCMC D4

Sump capacity maximum 15 litres (4 US gallons)

Normal operating angles 25° from horizontal in any direction

Oil pressure, in operating

speed range (steady state)..... 250kPa (36 psi)

Low oil pressure switch setting..... 83kPa (12 psi)

Electrical System

Generator 100A (12V), 55A (24V)

Starter type 12V, 4 kW

Number of teeth in flywheel..... 126

Number of teeth on starter..... 10

Cold Start Limits

Minimum cold start temperature (with aid). -15°C (5°F)

Batteries for min cold start..... 1 x 12V, 660 amp SAE

Data - 6TG2AM

1500 rev/min 1800 rev/min

Basic Technical Data

Prime power	92.5kW (124 hp).....	99kW (133 hp)
Number of cylinders.....	6	
Cylinder arrangement.....	In-line	
Cycle.....	4 stroke	
Induction system.....	Turbocharged	
Bore	100mm (3.937")	
Stroke	127mm (5.00")	
Compression ratio	16:1	
Cubic capacity	5.99 litres (365.0 in ³)	
Valves per cylinder	2	
Direction of rotation	Anti-clockwise viewed on flywheel	
Firing order	1, 5, 3, 6, 2, 4	
Total weight (wet).....	626 kg (1380 lbs) engine only including starter and generator.	

Cooling System

The coolant shown below is mandatory for use in all climates to ensure that adequate levels of corrosion inhibitor are present. It will give frost protection to -37°C (-34.6°F).

Coolant	50% inhibited ethylene glycol or 50% inhibited propylene glycol with 50% fresh clean water	
Fresh water flow	123 l/min (32.5 US galls/min)...	150 l/min (40 US galls/min)
Coolant pump speed and method of drive.....	1:1 Gear driven	
System capacity	24 litres (6.3 US galls)	
Pressure cap setting.....	50 kPa (7 psi)	
Protection switch setting.....	96°C (205°F)	
Sea water pump type.....	Jabsco gear driven model 25.4mm (1") full cam.	
Sea water suggested inlet hose diameter.....	32mm (1.25")	
Sea cock.....	Full flow 25.4mm (1.00") max lift of seawater pump 2m Full flow 38.1mm (1.25") max lift of seawater pump 4m	
Strainer	A raw water strainer must be included in the suction side of the circuit.	
Maximum sea water temperature.....	38°C (100°F)	
Sea water flow	71 l/min (18.8 US galls/min).....	91 l/min (24 US galls/min)

Fuel System

Recommended fuel specifications.....	BS2869 Class A2 ASTM D 975 Number 2D.	
Cetane number.....	45 minimum	
Fuel injection pump	Stanadyne rotary and electric stop. (Energised to run).	
Fuel lift pump	AC Delco type LU	
Delivery/hour	122 l/hr (32 US galls/min)	134 l/hr (35 US galls/min)
Pressure	30 kPa (4.4 PSI)	

Governor type.....Mechanical

Pipe size:

- Supply - Outside diameter..... 7.9mm (0.315")
- Supply - Bore 6.53mm (0.257")
- Return - Outside diameter..... 6.3mm (0.25")
- Return - Bore..... 4.93mm (0.194")

Maximum lift pump lift..... 1.8m (6 ft) to bottom of tank suction pipe.

Maximum fuel lift pump depression at inlet. 127mm (5") Hg

Fuel consumption at full power. 23.6 l/hr (6.2 US galls/hr)27.8 l/hr (7.3 US galls/hr)

Air Intake

Combustion airflow 6.12m³/min (216 ft³/min)..... 7.78m³/min (275 ft³/min)

Maximum engine compartment air temperature..... 60°C (140°F)

Maximum air temperature at engine inlet. 52°C (126°F)

Ventilation - maximum engine room depression.... 125mm H₂O (5in H₂O)

Suggested ventilation airflow

including combustion air. 32m³/min (1130 ft³/min)

Minimum cross section

of air duct (per engine). 477cm² (74sq ins) for hot climates.

.....240cm² (37sq ins) for temperate climates.

Exhaust

Exhaust gas flow 16.6m³/min (586 ft³/min20m³/min (706 ft³/min)

Maximum restriction measured

within (305 mm) 12" of turbocharger outlet..... 6kPa (1.26" Hg)

Recommended pipe bore (wet exhaust)..... 100mm (4.0")

Recommended pipe bore (dry)..... 76.2mm (3.0")

Minimum rise from sea water level

to exhaust outlet centreline..... 203mm (8.0")

Lubricating System

Recommended lubricating oil.AP1 CD/SE CCMC D4

Sump capacity maximum15 litres (4 US galls)

Normal operating angles 25° from horizontal in any direction

Oil pressure, in operating

speed range (steady state)..... 300 to 340 kPa (44 to 49 PSI)

Low oil pressure switch setting..... 83kPa (12 psi)

Electrical System

Generator Prestolite AS128 90A (12V) or 55A (24V)

Starter type.....Prestolite S115

Number of teeth in flywheel..... 126

Number of teeth on starter..... 10

Cold Start Limits

Minimum cold start temperature (with aid). -15°C (5°F)

Batteries for min

cold start.....a quantity of 2 off - 12V 315 Amps to BS3911 or 2 off - 12V, 535 amps to SAE J537

Data - 6TWGM

1500 rev/min 1800 rev/min

Basic Technical Data

Prime power	125.5kW (168.2 hp)	146kW (195.7 hp)
Number of cylinders.....	6	
Cylinder arrangement.....	In-line	
Cycle.....	4 stroke	
Induction system.....	Turbocharged, water to air charged cooled	
Bore	100mm (3.937")	
Stroke	127mm (5.00")	
Compression ratio	17:1	
Cubic capacity	5.99 litres (365.0 in3)	
Valves per cylinder	2	
Direction of rotation	Anti-clockwise viewed on flywheel	
Firing order	1, 5, 3, 6, 2, 4	
Total weight (wet).....	659kg (1450lbs) engine only including starter and generator.	

Cooling System

The coolant shown below is mandatory for use in all climates to ensure that adequate levels of corrosion inhibitor are present. It will give frost protection to -37°C (-34.6°F).

Coolant	50% inhibited ethylene glycol or 50% inhibited propylene glycol with 50% fresh clean water	
Fresh water flow	140 l/min (37 US galls/min)	172 l/min (45 US galls/min)
Coolant pump speed and method of drive.....	1:1 Gear driven	
System capacity	24 litres (6.3 US galls)	
Pressure cap setting.....	50 kPa (7 psi)	
Protection switch setting.....	96°C (205°F)	
Sea water pump type.....	Jabsco gear driven model 25.4 mm (1") full cam.	
Sea water suggested inlet hose diameter.....	32mm (1.25")	
Sea cock.....	Full flow 25.4mm (1.00") max lift of seawater pump 2m Full flow 38.1mm (1.25") max lift of seawater pump 4m	
Strainer	A raw water strainer must be included in the suction side of the circuit.	
Maximum sea water temperature.....	38°C (100°F)	
Sea water flow	71 l/min (18.8 US galls/min).....	91 l/min (24 US galls/min)

Fuel System

Recommended fuel specifications.....	BS2869 Class A2 ASTM D 975 Number 2D.	
Cetane number.....	45 minimum	
Fuel injection pump ...	Stanadyne rotary and electric stop. (Energised to run) / *Delphi DP200EG (Energised to run)	
Fuel lift pump	AC Delco type LU	
Delivery/hour	122 l/hr (32 US galls/min)	134 l/hr (35 US galls/min)
Pressure	30 kPa (4.4 PSI)	

*From March 2014.

Governor type..... Mechanical / **Electrical

Pipe size:

- Supply - Outside diameter..... 7.9mm (0.315")
- Supply - Bore 6.53mm (0.257")
- Return - Outside diameter..... 6.3mm (0.25")
- Return - Bore..... 4.93mm (0.194")

Maximum lift pump lift..... 1.8 m (6 ft) to bottom of tank suction pipe.

Maximum fuel lift pump depression at inlet. 127mm (5") Hg

Fuel consumption at full power. ... 31.5 l/hr (6.93 US galls/hr) 37.6 l/hr (8.3 US galls/hr)

Air Intake

Combustion airflow 8.07m³/min (285 ft³/min) 10.62m³/min (375 ft³/min)

Maximum engine compartment air temperature..... 60°C (140°F)

Maximum air temperature at engine inlet. 52°C (126°F)

Ventilation - maximum engine room depression..... 125mm H₂O (5in H₂O)

Minimum cross section

of air duct (per engine). 626 cm² (97 sq ins) for hot climates.

..... 316 cm² (49 sq ins) for temperate climates.

Exhaust

Exhaust gas flow 27.8m³/min (800 ft³/min 33m³/min (950 ft³/min)

Maximum restriction measured

within (305 mm) 12" of turbocharger outlet..... 6kPa (1.26" Hg)

Recommended pipe bore (wet exhaust)..... 127mm (5.0")

Recommended pipe bore (dry)..... 76.2mm (3.0")

Minimum rise from sea water level

to exhaust outlet centreline..... 203mm (8.0")

Lubricating System

Recommended lubricating oil. AP1 CD/SE CCMC D4

Sump capacity maximum 15 litres (4 US galls)

Normal operating angles 25° from horizontal in any direction

Oil pressure, in operating

speed range (steady state)..... 300 to 340kPa (44 to 49 PSI)

Low oil pressure switch setting..... 83kPa (12 psi)

Electrical System

Generator Prestolite AS128 90A (12V) or 55A (24V)

Starter type..... Prestolite S115

Number of teeth in flywheel..... 126

Number of teeth on starter..... 10

Cold Start Limits

Minimum cold start temperature (with aid). -15°C (5°F)

Batteries for min

cold start..... a quantity of 2 off - 12V 340 Amps to BS3911 or 2 off - 12V, 540 amps to SAE J537

**From March 2014.

Data - 4.4GM Radiator

1500 rev/min 1800 rev/min

Basic Technical Data

Prime power, (mechanical).....	427kW (57.3 hp).....	49.1kW (65.8 hp)
Number of cylinders.....	4	
Cylinder arrangement.....	In-line	
Cycle.....	4 stroke	
Induction system.....	Naturally Aspirated	
Bore.....	100mm (3.937")	
Stroke.....	127mm (5.00")	
Compression ratio.....	18.23:1	
Cubic capacity.....	4.4 litres	
Valves per cylinder.....	2	
Direction of rotation.....	Anti-clockwise viewed on flywheel	
Firing order.....	1, 3, 4, 2	
Total weight (dry).....	484kg (1067lbs) engine only including starter and alternator.	

Cooling System

The coolant shown below is mandatory for use in all climates to ensure that adequate levels of corrosion inhibitor are present. It will give frost protection to -37°C. (-34.6°F)

Maximum Airon.....	55°C	
Air Velocity.....	5 m/s	
Volume Flow.....	1.53 m ³ /s	
Air pressure Drop over Radiator.....	320 kPa	
Maximum Duct Restriction.....	200 Pa	
Combustion air flow.....	3.92 m ³ /min @ 1500.....	3.58 m ³ /min @ 1800
Coolant.....	50% inhibited ethylene glycol or 50% inhibited propylene glycol with 50% fresh clean water	
Coolant water flow.....	100 l/min (26.4 US galls/min).....	116 l/min (30.6 US galls/min)
Coolant pump speed and method of drive.....	Gear driven	
System capacity.....	16.5 litres (4.4 US galls)	
Pressure cap setting.....	100kPa (14.5 psi)	
Protection switch setting.....	96°C (205°F)	

Fuel System

Recommended fuel specifications.....	BS2869 Class A2 ASTM D 975 Number 2D.	
Cetane number.....	45 minimum.	
Fuel injection pump.....	Delphi rotary	
Fuel lift pump.....	Electric	
Pressure.....	30 - 75kPa (4.4 - 10.9 PSI)	
Delivery/hr.....	120 - 150 ltr/hr (31.7 US galls/hr to 39.6 US galls/hr)	
Governor type.....	L Series, electronic governor	

Pipe size:

- Supply - Outside diameter..... 7.9mm (0.315")
- Supply - Bore 6.53mm (0.257")
- Return - Outside diameter 6.3mm (0.25")
- Return - Bore..... 4.93mm (0.194")

Maximum lift pump lift (clean filter)..... 17kPa at 1.7m using 8mm dia. bore pipe

Maximum fuel lift pump depression at inlet. 127mm (5") Hg

Fuel consumption at full power. 12.2 l/hr (3.2 US galls/hr) 14.5 l/hr (3.8 US galls/hr)

Air Intake

Combustion airflow 3.19m³/min (113 ft³/min) 3.58m³/min (126 ft³/min)

Maximum engine compartment air temperature..... 52°C (126°F)

Maximum air temperature at engine inlet. 52°C (126°F)

Exhaust

Exhaust gas flow 7.6m³/min (268 ft³/min)..... 8.8m³/min (311 ft³/min)

Maximum restriction measured
within (305 mm) 12" outlet..... 15kPa (4.4" Hg)

Recommended pipe bore (wet exhaust)..... 76mm (3.0")

Recommended pipe bore (dry)..... 57mm (2.25")

Minimum rise from sea water level
to exhaust outlet centreline..... 203mm (8.0")

Lubricating System

Recommended lubricating oil. AP1 CG4/CH4 ACEA E3/E5

Sump capacity maximum 8.5 litres (2.2 US galls/min)

Normal operating angles 25° from horizontal in any direction

Oil pressure, in operating
speed range (steady state)..... 250kPa (36 psi)

Low oil pressure switch setting..... 83kPa (12 psi)

Electrical System

Generator 100A (12V), 55A (24V)

Starter..... 12 volt 4.0 kW

Number of teeth in flywheel..... 126

Number of teeth on starter..... 9

Cold Start Limits

Minimum cold start temperature (with aid). -15°C(5°F)

Batteries for min cold start..... 1 x 12 volt 660 Amp SAE

Data - 4.4TGM Radiator

1500 rev/min 1800 rev/min

Basic Technical Data

Prime power (mechanical).....	56.4 kW (75.6 hp).....	63.6 kW (85.3 hp)
Number of cylinders.....	4	
Cylinder arrangement.....	In-line	
Cycle.....	4 stroke	
Induction system.....	Turbocharged	
Bore.....	100mm (3.937")	
Stroke.....	127mm (5.00")	
Compression ratio.....	19.3:1	
Cubic capacity.....	4.4 litres	
Valves per cylinder.....	2	
Direction of rotation.....	Anti-clockwise viewed on flywheel	
Firing order.....	1, 3, 4, 2	
Total weight (wet).....	527kg (1162 lbs) engine only including starter and alternator.	

Cooling System

The coolant shown below is mandatory for use in all climates to ensure that adequate levels of corrosion inhibitor are present. It will give frost protection to -37°C. (-34.6°F)

Maximum Airon.....	55°C	
Air Velocity.....	5 m/s	
Volume Flow.....	1.53 m ³ /s	
Air pressure Drop over Radiator.....	320 kPa	
Maximum Duct Restriction.....	200 Pa	
Combustion air flow.....	5.2 m ³ /min @ 1500.....	6.1 m ³ /min @ 1800
Coolant.....	50% inhibited ethylene glycol or 50% inhibited propylene glycol with 50% fresh clean water	
Coolant water flow.....	145 l/min (37.3 US galls/min).....	171 l/min (45.2 US galls/min)
Coolant pump speed and method of drive.....	Gear driven	
System capacity.....	15.5 litres (4 US galls)	
Pressure cap setting.....	100kPa (14.5 psi)	
Protection switch setting.....	96°C (205°F)	

Fuel System

Recommended fuel specifications.....	BS2869 Class A2 ASTM D 975 Number 2D.	
Cetane number.....	45 minimum.	
Fuel injection pump.....	Delphi rotary	
Fuel lift pump.....	Electric	
Delivery/hr.....	120 - 150 ltr/hr (31.7 US galls/hr to 39.6 US galls/hr)	
 30 - 75 kPa (4.4 - 10.9 PSI)	
Governor type.....	L series electronic governor	

Pipe size:

- Supply - Outside diameter..... 7.9mm (0.315")
- Supply - Bore 6.53mm (0.257")
- Return - Outside diameter 6.3mm (0.25")
- Return - Bore..... 4.93mm (0.194")

Maximum lift pump lift (clean filter)..... 17kPa at 1.7m using 8mm dia. bore pipe.

Maximum fuel lift pump depression at inlet. 127mm (5.00") Hg

Fuel consumption at full power. 14.8 l/hr (3.9 US galls/hr) 16.9 l/hr (4.5 US galls/hr)

Air Intake

Combustion airflow 5.0 m³/min (177 ft³/min) 5.97 m³/min (211 ft³/min)

Maximum engine compartment air temperature..... 52°C (126°F)

Maximum air temperature at engine inlet. 52°C (126°F)

Exhaust

Exhaust gas flow 10.1m³/min (357 ft³/min)..... 13.0m³/min (459 ft³/min)

Maximum restriction measured
within (305 mm) 12" outlet..... 15kPa (4.4" Hg)

Recommended pipe bore (wet exhaust)..... 76.2mm (3.0")

Recommended pipe bore (dry)..... 57mm (2.24")

Minimum rise from sea water level
to exhaust outlet centreline..... 203mm (8.0")

Lubricating System

Recommended lubricating oil. AP1 CG4/CH4 or ACEA E3/E5

Sump capacity maximum 8.5 litres (2.2 US galls/min)

Normal operating angles 25° from horizontal in any direction

Oil pressure, in operating
speed range (steady state)..... 250kPa (36 psi)

Low oil pressure switch setting..... 83kPa (12 psi)

Electrical System

Generator 100A (12V), 55A (24V)

Starter type..... 12V 4.0kW

Number of teeth in flywheel..... 126

Number of teeth on starter..... 10

Cold Start Limits

Minimum cold start temperature (with aid). -15°C(5°F)

Batteries for min cold start..... 1 x 12 volt 660 Amp SAE

Data - 4.4TWGM Radiator

1500 rev/min 1800 rev/min

Basic Technical Data

Prime power (mechanical)..... 75kW (101 hp) 82.7kW (111 hp)
 Number of cylinders..... 4
 Cylinder arrangement..... In-line
 Cycle..... 4 stroke
 Induction system..... Turbocharged, aftercooled
 Bore 100mm (3.937")
 Stroke 127mm (5.00")
 Compression ratio 18.23:1
 Cubic capacity 4.4 litres (19.3 in³)
 Valves per cylinder 2
 Direction of rotation Anti-clockwise viewed on flywheel
 Firing order 1, 3, 4, 2
 Total weight (wet)..... 570kg (1257 lbs) engine only including starter and alternator.

Cooling System

The coolant shown below is mandatory for use in all climates to ensure that adequate levels of corrosion inhibitor are present. It will give frost protection to -37°C. (-34.6°F)

Maximum Airon.....55°C
 Air Velocity..... 5 m/s
 Volume Flow 1.53 m³/s
 Air pressure Drop over Radiator..... 320 kPa
 Maximum Duct Restriction..... 200 Pa
 Combustion air flow 7.6 m³/min @ 1500 9.56 m³/min @ 1800
 Coolant 50% inhibited ethylene glycol or 50% inhibited propylene glycol with 50% fresh clean water
 Coolant water flow 145 l/min (37.3 US galls/min) .. 171 l/min (45.2 US galls/min)
 Coolant pump speed and method of drive..... 1:1 Gear driven
 System capacity 20 litres (4.4 US galls)
 Pressure cap setting..... 100kPa (14.5 psi)
 Protection switch setting..... 96°C (205°F)

Fuel System

Recommended fuel specifications..... BS2869 Class A2 ASTM D 975 Number 2D.
 Cetane number..... 45 minimum.
 Fuel injection pump Delphi rotary
 Fuel lift pump Electric
 Delivery/hour 120 - 150 l/hr (31.7 US galls/hr to 39.6 US galls/hr)
 Pressure 30 - 75kPa (4.4 - 10.9 PSI)
 Governor type..... L series electronic governor

Pipe size:

- Supply - Outside diameter 7.9mm (0.315")
- Supply - Bore 6.53mm (0.257")
- Return - Outside diameter 6.3mm (0.25")
- Return - Bore..... 4.93mm (0.194")

Maximum lift pump lift (clean filter)..... 17kPa at 1.7m using 8mm dia. bore pipe

Maximum fuel lift pump depression at inlet. 127mm (5") Hg

Fuel consumption at full power. 18.6 l/hr (4.9 US galls/hr) 22 l/hr (5.8 US galls/hr)

Air Intake

Combustion airflow 7.3 m³/min (258 ft³/min) 9.4 m³/min (332 ft³/min)

Maximum engine compartment air temperature..... 52°C (126°F)

Maximum air temperature at engine inlet. 52°C (126°F)

Exhaust

Exhaust gas flow 17.7m³/min (625 ft³/min)..... 21.2m³/min (749 ft³/min)

Maximum restriction measured
within (305 mm) 12" outlet..... 15kPa (4.4" Hg)

Recommended pipe bore (wet exhaust)..... 100mm (4.0")

Recommended pipe bore (dry)..... 76.2mm (3.0")

Minimum rise from sea water level
to exhaust outlet centreline..... 203mm (8.0")

Lubricating System

Recommended lubricating oil. AP1 CG4/CH4 or ACEA E3/E5

Sump capacity maximum 15 litres (4 US galls/min)

Normal operating angles 25° from horizontal in any direction

Oil pressure, in operating
speed range (steady state)..... 250kPa (36 psi)

Low oil pressure switch setting..... 83kPa (12 psi)

Electrical System

Generator 100A (12V), 55A (24V)

Starter type..... 12 V 4.0 kW

Number of teeth in flywheel..... 126

Number of teeth on starter..... 10

Cold Start Limits

Minimum cold start temperature (with aid). -15°C(5°F)

Batteries for min cold start..... 1 x 12 volt 660 amp SAE

Data - 4.4TW2GM Radiator

1500 rev/min 1800 rev/min

Basic Technical Data

Prime power	93.4kW (125.3 hp)	106.8kW (143 hp)
Number of cylinders.....	4	
Cylinder arrangement.....	In-line	
Cycle.....	4 stroke	
Induction system.....	Turbocharged/Aftercooled	
Bore	100mm (3.937")	
Stroke	127mm (5.00")	
Compression ratio	19.3:1	
Cubic capacity	4.4 litres (243 in ³)	
Valves per cylinder	2	
Direction of rotation	Anti-clockwise viewed on flywheel	
Firing order	1, 3, 4, 2	
Total weight (wet).....	570kg (1257 lbs) engine only including starter and generator.	

Cooling System

The coolant shown below is mandatory for use in all climates to ensure that adequate levels of corrosion inhibitor are present. It will give frost protection to -37°C (-34.6°F).

Maximum Airon.....	55°C	
Air Velocity.....	5 m/s	
Volume Flow	1.53 m ³ /s	
Air pressure Drop over Radiator.....	320 kPa	
Maximum Duct Restriction.....	200 Pa	
Combustion air flow	8.31 m ³ /min @ 1500.....	7.89 m ³ /min @ 1800
Coolant	50% inhibited ethylene glycol or 50% inhibited propylene glycol with 50% fresh clean water	
Coolant water flow	145 l/min (37.3 US galls/min) ..	171 l/min (45.2 US galls/min)
Coolant pump speed and method of drive.....	1:1 Gear driven	
System capacity	16.5 litres (4.8 US galls)	
Pressure cap setting.....	50kPa (7 psi)	
Protection switch setting.....	96°C (205°F)	

Fuel System

Recommended fuel specifications.....	BS2869 Class A2 ASTM D 975 Number 2D.	
Cetane number.....	45 minimum	
Fuel injection pump	Delphi rotary	
Fuel lift pump.....	Electric	
Delivery.....	120-150l/hr (31.7 US galls/hr to 39.6 US galls/hr)	
Pressure	30-75kPa (4.4-10.9 PSI)	
Governor type.....	L series electronic governor	

Pipe size:

- Supply - Outside diameter..... 7.9mm (0.315")
- Supply - Bore 6.53mm (0.257")
- Return - Outside diameter 6.3mm (0.25")
- Return - Bore..... 4.93mm (0.194")

Maximum lift pump lift..... 1.8m (6 ft) to bottom of tank suction pipe.

Maximum fuel lift pump depression at inlet. 127mm (5") Hg

Fuel consumption at full power. 24.6 l/hr (6.5 US galls/hr)27.7 l/hr (7.3 US galls/hr)

Air Intake

Combustion airflow 7.9m³/min (279 ft³/min)..... 9.9m³/min (350 ft³/min)

Maximum engine compartment air temperature..... 60°C (140°F)

Maximum air temperature at engine inlet. 52°C (126°F)

Ventilation - maximum engine room depression..... 125mm H₂O (5 in H₂O)

Exhaust

Exhaust gas flow 19.5m³/min (689 ft³/min)..... 24.3m³/min (858 ft³/min)

Maximum restriction measured
within (305 mm) 12" outlet..... 15kPa (4.4" Hg)

Recommended pipe bore (wet exhaust)..... 100mm (4.0")

Recommended pipe bore (dry)..... 76.2mm (3.0")

Minimum rise from sea water level to
exhaust outlet centreline..... 203mm (8.0")

Lubricating System

Recommended lubricating oil.AP1 CD/SE CCMC D4

Sump capacity maximum 15 litres (4 US gallons)

Normal operating angles 25° from horizontal in any direction

Oil pressure, in operating
speed range (steady state)..... 250kPa (36 psi)

Low oil pressure switch setting..... 83kPa (12 psi)

Electrical System

Generator 100A (12V), 55A (24V)

Starter type..... 12V, 4 kW

Number of teeth in flywheel..... 126

Number of teeth on starter..... 10

Cold Start Limits

Minimum cold start temperature (with aid). -15°C (5°F)

Batteries for min cold start..... 1 x 12V, 660 amp SAE

California

Proposition 65 Warning

Diesel engine exhaust and some of its constituents are known to the State of California to cause cancer, birth defects, and other reproductive harm.



Perkins[®]
Marine Power

All information in this document is substantially correct at time of printing and may be altered subsequently.
Part No. N38143 issue 11
Produced in England ©2024

Perkins Marine
22 Cobham Road,
Ferndown Industrial Estate,
Wimborne, Dorset, BH21 7PW, England.
Tel: +44 (0)1202 796000,
E-mail: Marine@Perkins.com

Web: www.perkins.com/Marine