

# Operation and Maintenance Manual

---

## **2506-15 Industrial Engine**

---

MGA (Engine)

MGB (Engine)

MGD (Engine)



## Important Safety Information

Most accidents that involve product operation, maintenance and repair are caused by failure to observe basic safety rules or precautions. An accident can often be avoided by recognizing potentially hazardous situations before an accident occurs. A person must be alert to potential hazards. This person should also have the necessary training, skills and tools to perform these functions correctly.

**Incorrect operation, lubrication, maintenance or repair of this product can be dangerous and could result in injury or death.**

**Do not operate or perform any lubrication, maintenance or repair on this product, until you have read and understood the operation, lubrication, maintenance and repair information.**

Safety precautions and warnings are provided in this manual and on the product. If these hazard warnings are not heeded, bodily injury or death could occur to you or to other persons.

The hazards are identified by the "Safety Alert Symbol" and followed by a "Signal Word" such as "DANGER", "WARNING" or "CAUTION". The Safety Alert "WARNING" label is shown below.



The meaning of this safety alert symbol is as follows:

**Attention! Become Alert! Your Safety is Involved.**

The message that appears under the warning explains the hazard and can be either written or pictorially presented.

Operations that may cause product damage are identified by "NOTICE" labels on the product and in this publication.

**Perkins cannot anticipate every possible circumstance that might involve a potential hazard. The warnings in this publication and on the product are, therefore, not all inclusive. You must not use this product in any manner different from that considered by this manual without first satisfying yourself that you have considered all safety rules and precautions applicable to the operation of the product in the location of use, including site-specific rules and precautions applicable to the worksite. If a tool, procedure, work method or operating technique that is not specifically recommended by Perkins is used, you must satisfy yourself that it is safe for you and for others. You should also ensure that you are authorized to perform this work, and that the product will not be damaged or become unsafe by the operation, lubrication, maintenance or repair procedures that you intend to use.**

The information, specifications, and illustrations in this publication are on the basis of information that was available at the time that the publication was written. The specifications, torques, pressures, measurements, adjustments, illustrations, and other items can change at any time. These changes can affect the service that is given to the product. Obtain the complete and most current information before you start any job. Perkins dealers or Perkins distributors have the most current information available.



**When replacement parts are required for this product Perkins recommends using Perkins replacement parts.**

**Failure to heed this warning can lead to premature failures, product damage, personal injury or death.**

---

**In the United States, the maintenance, replacement, or repair of the emission control devices and systems may be performed by any repair establishment or individual of the owner's choosing.**

## Table of Contents

|                                               |    |                                    |    |
|-----------------------------------------------|----|------------------------------------|----|
| Foreword .....                                | 4  | Cold Weather Operation .....       | 39 |
| <b>Safety Section</b>                         |    | <b>Maintenance Section</b>         |    |
| Safety Messages .....                         | 6  | Refill Capacities.....             | 42 |
| General Hazard Information.....               | 7  | Maintenance Interval Schedule..... | 54 |
| Burn Prevention.....                          | 10 | <b>Warranty Section</b>            |    |
| Fire Prevention and Explosion Prevention..... | 11 | Warranty Information.....          | 78 |
| Crushing Prevention and Cutting Prevention..  | 13 | <b>Index Section</b>               |    |
| Mounting and Dismounting .....                | 13 | Index.....                         | 79 |
| Before Starting Engine .....                  | 14 |                                    |    |
| Engine Starting.....                          | 14 |                                    |    |
| Engine Stopping .....                         | 14 |                                    |    |
| Electrical System.....                        | 15 |                                    |    |
| Engine Electronics.....                       | 16 |                                    |    |
| <b>Product Information Section</b>            |    |                                    |    |
| General Information .....                     | 17 |                                    |    |
| Model Views .....                             | 18 |                                    |    |
| Product Identification Information .....      | 21 |                                    |    |
| <b>Operation Section</b>                      |    |                                    |    |
| Lifting and Storage .....                     | 26 |                                    |    |
| Gauges and Indicators .....                   | 27 |                                    |    |
| Features and Controls.....                    | 28 |                                    |    |
| Engine Diagnostics .....                      | 33 |                                    |    |
| Engine Starting.....                          | 35 |                                    |    |
| Engine Operation .....                        | 37 |                                    |    |
| Engine Stopping .....                         | 38 |                                    |    |

## Foreword

### California Proposition 65 Warning

**Diesel engine exhaust and some of its constituents are known to the State of California to cause cancer, birth defects, and other reproductive harm.**



**WARNING – This product can expose you to chemicals including ethylene glycol, which is known to the State of California to cause birth defects or other reproductive harm. For more information go to:**

**[www.P65Warnings.ca.gov](http://www.P65Warnings.ca.gov)**

**Do not ingest this chemical. Wash hands after handling to avoid incidental ingestion.**



**WARNING – This product can expose you to chemicals including lead and lead compounds, which are known to the State of California to cause cancer, birth defects, or other reproductive harm. For more information go to:**

**[www.P65Warnings.ca.gov](http://www.P65Warnings.ca.gov)**

**Wash hands after handling components that may contain lead.**

### Literature Information

This manual contains safety, operation instructions, lubrication, and maintenance information. This manual should be stored in or near the engine area in a literature holder or literature storage area. Read, study, and keep the manual with the literature and engine information.

English is the primary language for all Perkins publications. The English used facilitates translation and consistency.

Some photographs or illustrations in this manual show details or attachments that may be different from your engine. Guards and covers may have been removed for illustrative purposes. Continuing improvement and advancement of product design may have caused changes to your engine which are not included in this manual. Whenever a question arises regarding your engine, or this manual, please consult with your Perkins dealer or your Perkins distributor for the latest available information.

### Safety

This safety section lists basic safety precautions. In addition, this section identifies hazardous, warning situations. Read and understand the basic precautions listed in the safety section before operating or performing lubrication, maintenance, and repair on this product.

### Operation

Operating techniques outlined in this manual are basic. The operating techniques assist with developing the skills and techniques required to operate the engine more efficiently and economically. Skill and techniques develop as the operator gains knowledge of the engine and the capabilities of the engine.

The operation section is a reference for operators. Photographs and illustrations guide the operator through procedures of inspecting, starting, operating, and stopping the engine. This section also includes a discussion of electronic diagnostic information.

### Maintenance

The maintenance section is a guide to engine care. The illustrated, step-by-step instructions are grouped by service hours and/or calendar time maintenance intervals. Items in the maintenance schedule are referenced to detailed instructions that follow.

Recommended service should be performed at the appropriate intervals as indicated in the Maintenance Interval Schedule. The actual operating environment of the engine also governs the Maintenance Interval Schedule. Therefore, under severe, dusty, wet, or freezing cold operating conditions, more frequent lubrication, and maintenance than is specified in the Maintenance Interval Schedule may be necessary.

The maintenance schedule items are organized for a preventive maintenance management program. If the preventive maintenance program is followed, a periodic tune-up is not required. The implementation of a preventive maintenance management program should minimize operating costs through cost avoidances resulting from reductions in unscheduled downtime and failures.

## **Maintenance Intervals**

Perform maintenance on items at multiples of the original requirement. Each level and/or individual items in each level should be shifted ahead or back depending upon your specific maintenance practices, operation, and application. Perkins recommends that the maintenance schedules be reproduced and displayed near the engine as a convenient reminder. Perkins also recommends that a maintenance record be maintained as part of the permanent record of the engine.

Your authorized Perkins dealer or your Perkins distributor can assist you in adjusting your maintenance schedule to meet the needs of your operating environment.

## **Overhaul**

Major engine overhaul details are not covered in the Operation and Maintenance Manual except for the interval and the maintenance items in that interval. Major repairs are best left to trained personnel or an authorized Perkins distributor or dealer. Your Perkins dealer or your Perkins distributor offers various options regarding overhaul programs. If you experience a major engine failure, there are also numerous after failure overhaul options available. Consult with your Perkins dealer or your Perkins distributor for information regarding these options.

# Safety Section

i02581679

## Safety Messages

There may be several specific warning signs on your engine. The exact location and a description of the warning signs are reviewed in this section. Please become familiar with all warning signs.

Ensure that all of the warning signs are legible. Clean the warning signs or replace the warning signs if the words cannot be read or if the illustrations are not visible. Use a cloth, water, and soap to clean the warning signs. Do not use solvents, gasoline, or other harsh chemicals. Solvents, gasoline, or harsh chemicals could loosen the adhesive that secures the warning signs. The warning signs that are loosened could drop off of the engine.

Replace any warning sign that is damaged or missing. If a warning sign is attached to a part of the engine that is replaced, install a new warning sign on the replacement part. Your Perkins dealer or your distributor can provide new warning signs.

### (1) Universal Warning



**Do not operate or work on this equipment unless you have read and understand the instructions and warnings in the Operation and Maintenance Manuals. Failure to follow the instructions or heed the warnings could result in serious injury or death.**

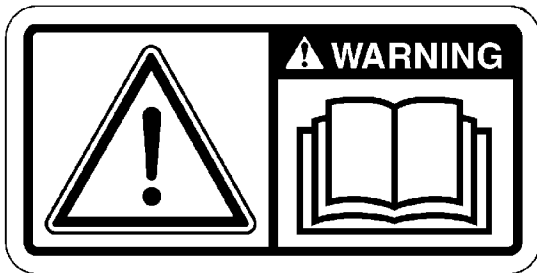

Illustration 1

g01154807

Typical example

The Universal Warning label (1) is located on both sides of the engine. Refer to illustration 2 .

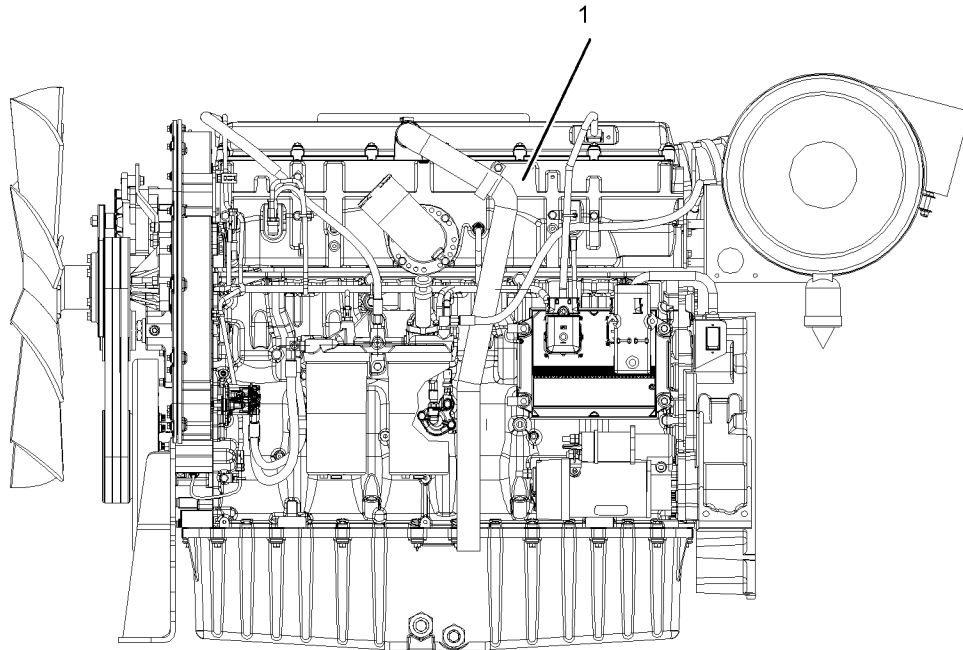

Illustration 2  
Typical example

g01294688

i08312758

## General Hazard Information

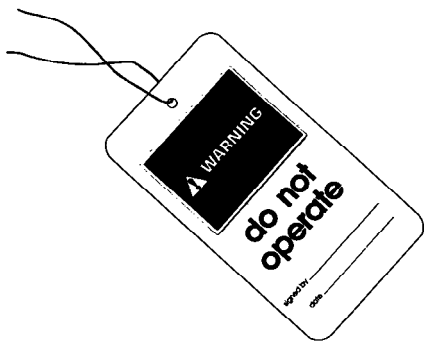

Illustration 3

g00104545

Attach a “Do Not Operate” warning tag or a similar warning tag to the start switch or to the controls before you service the equipment or before you repair the equipment.

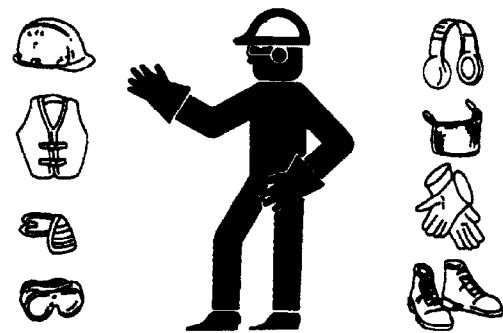

Illustration 4

g00702020

Wear a hard hat, protective glasses, and other protective equipment, as required.

Do not wear loose clothing or jewelry that can snag on controls or on other parts of the engine.

Make sure that all protective guards and all covers are secured in place on the engine.

Keep the engine free from foreign material. Remove debris, oil, tools, and other items from the deck, from walkways, and from steps.

Safety Section  
General Hazard Information

---

Never put maintenance fluids into glass containers. Drain all liquids into a suitable container.

Obey all local regulations for the disposal of liquids.

Use all cleaning solutions with care.

Report all necessary repairs.

Do not allow unauthorized personnel on the equipment.

Disconnect the batteries when maintenance is performed or when the electrical system is serviced. Disconnect the battery ground leads. Tape the leads to help prevent sparks. If equipped, allow the diesel exhaust fluid to be purged before disconnecting the battery.

Perform maintenance on the engine with the equipment in the servicing position. Refer to the OEM information for the procedure for placing the equipment in the servicing position.

Do not attempt any repairs that are not understood. Use the proper tools. Replace any equipment that is damaged or repair the equipment.

For initial start-up of a new engine or for starting an engine that has been serviced, make provisions to stop the engine if an overspeed occurs. The stopping of the engine may be accomplished by shutting off the fuel supply and/or the air supply to the engine. Ensure that only the fuel supply line is shut off. Ensure that the fuel return line is open.

Start the engine from the operators station (cab). Never short across the starting motor terminals or the batteries. This action could bypass the engine neutral start system and/or the electrical system could be damaged.

Engine exhaust contains products of combustion which may be harmful to your health. Always start the engine and operate the engine in a ventilated area. If the engine is in an enclosed area, vent the engine exhaust to the outside.

Use caution when cover plates are removed. Gradually loosen, but do not remove the last two bolts or nuts that are located at opposite ends of the cover plate or the device. Before removing the last two bolts or nuts, pry the cover loose to relieve any spring pressure or other pressure.

## Pressure Air and Water

Pressurized air and/or water can cause debris and/or hot water to be blown out. This action could result in personal injury.

The direct application of pressurized air or pressurized water to the body could result in personal injury.

When pressurized air and/or water is used for cleaning, wear protective clothing, protective shoes, and eye protection. Eye protection includes goggles or a protective face shield.

The maximum air pressure for cleaning purposes must be below 205 kPa (30 psi). The maximum water pressure for cleaning purposes must be below 275 kPa (40 psi).

## Fluid Penetration

Pressure can be trapped in the hydraulic circuit long after the engine has been stopped. The pressure can cause hydraulic fluid or items such as pipe plugs to escape rapidly if the pressure is not relieved correctly.

Do not remove any hydraulic components or parts until pressure has been relieved or personal injury may occur. Do not disassemble any hydraulic components or parts until pressure has been relieved or personal injury may occur. Refer to the OEM information for any procedures that are required to relieve the hydraulic pressure.

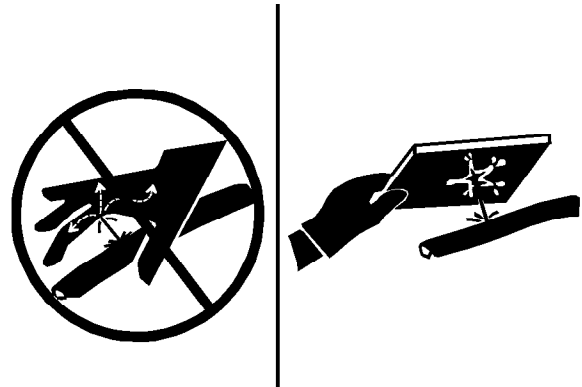

Illustration 5

g00687600

Always use a board or cardboard when you check for a leak. Leaking fluid that is under pressure can penetrate body tissue. Fluid penetration can cause serious injury and possible death. A pin hole leak can cause severe injury. If fluid is injected into your skin, you must get treatment immediately. Seek treatment from a doctor that is familiar with this type of injury.

## Containing Fluid Spillage

Care must be taken to ensure that fluids are contained during performance of inspection, maintenance, testing, adjusting, and repair of the engine. Make provision to collect the fluid with a suitable container before any compartment is opened or before any component is disassembled.

- Only use the tools that are suitable for collecting fluids and equipment that is suitable for collecting fluids.



- Only use the tools that are suitable for containing fluids and equipment that is suitable for containing fluids.

Obey all local regulations for the disposal of liquids.

## Static Electricity Hazard when Fueling with Ultra-low Sulfur Diesel Fuel

The removal of sulfur and other compounds in ultra-low sulfur diesel fuel (ULSD fuel) decreases the conductivity of ULSD and increases the ability of ULSD to store static charge. Refineries may have treated the fuel with a static dissipating additive. Many factors can reduce the effectiveness of the additive over time. Static charges can build up in ULSD fuel while the fuel is flowing through fuel delivery systems. Static electricity discharge when combustible vapors are present could result in a fire or explosion. Ensure that the entire system used to refuel your machine (fuel supply tank, transfer pump, transfer hose, nozzle, and others) is properly grounded and bonded. Consult with your fuel or fuel system supplier to ensure that the delivery system complies with fueling standards for proper grounding and bonding.

### **WARNING**

**Avoid static electricity risk when fueling. Ultra-low sulfur diesel fuel (ULSD fuel) poses a greater static ignition hazard than earlier diesel formulations with a higher sulfur contents. Avoid death or serious injury from fire or explosion. Consult with your fuel or fuel system supplier to ensure the delivery system is in compliance with fueling standards for proper grounding and bonding practices.**

## Inhalation

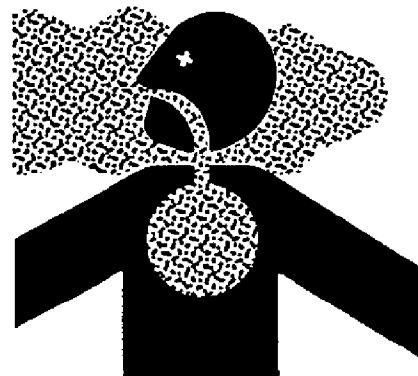

Illustration 6

g00702022

## Exhaust

Use caution. Exhaust fumes can be hazardous to health. If you operate the equipment in an enclosed area, adequate ventilation is necessary.

## Hexavalent Chromium

Perkins equipment and replacement parts comply with applicable regulations and requirements where originally sold. Perkins recommends the use of only genuine Perkins replacement parts.

Hexavalent chromium has occasionally been detected on exhaust and heat shield systems on Perkins engines. Although laboratory testing is the only accurate way to know if hexavalent chromium is, in fact, present, the presence of a yellow deposit in areas of high heat (for example, exhaust system components or exhaust insulation) may be an indication of the presence of hexavalent chromium.

Use caution if you suspect the presence of hexavalent chromium. Avoid skin contact when handling items that you suspect may contain hexavalent chromium, and avoid inhalation of any dust in the suspect area. Inhalation of, or skin contact with, hexavalent chromium dust may be hazardous to your health.

## Safety Section

### Burn Prevention

If such yellow deposits are found on the engine, engine component parts, or associated equipment or packages, Perkins recommends following local health and safety regulations and guidelines, utilizing good hygiene, and adhering to safe work practices when handling the equipment or parts. Perkins also recommends the following:

- Wear appropriate Personal Protective Equipment (PPE)
- Wash your hands and face with soap and water prior to eating, drinking, or smoking, and also during rest room breaks, to prevent ingestion of any yellow powder
- Never use compressed air for cleaning areas suspected of containing hexavalent chromium
- Avoid brushing, grinding, or cutting materials suspected of containing hexavalent chromium
- Obey environmental regulations for the disposal of all materials that may contain or have come into contact with hexavalent chromium
- Stay away from areas that might have hexavalent chromium particles in the air.

### Asbestos Information

Perkins equipment and replacement parts that are shipped from Perkins engine company limited are asbestos free. Perkins recommends the use of only genuine Perkins replacement parts. Use the following guidelines when you handle any replacement parts that contain asbestos or when you handle asbestos debris.

Use caution. Avoid inhaling dust that might be generated when you handle components that contain asbestos fibers. Inhaling this dust can be hazardous to your health. The components that may contain asbestos fibers are brake pads, brake bands, lining material, clutch plates, and some gaskets. The asbestos that is used in these components is usually bound in a resin or sealed in some way. Normal handling is not hazardous unless airborne dust that contains asbestos is generated.

If dust that may contain asbestos is present, there are several guidelines that should be followed:

- Never use compressed air for cleaning.
- Avoid brushing materials that contain asbestos.
- Avoid grinding materials that contain asbestos.
- Use a wet method to clean up asbestos materials.
- A vacuum cleaner that is equipped with a high efficiency particulate air filter (HEPA) can also be used.

- Use exhaust ventilation on permanent machining jobs.
- Wear an approved respirator if there is no other way to control the dust.
- Comply with applicable rules and regulations for the work place. In the United States, use Occupational Safety and Health Administration (OSHA) requirements. These OSHA requirements can be found in "29 CFR 1910.1001".
- Obey environmental regulations for the disposal of asbestos.
- Stay away from areas that might have asbestos particles in the air.

### Dispose of Waste Properly

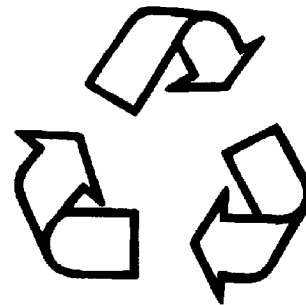

Illustration 7

g00706404

Improperly disposing of waste can threaten the environment. Potentially harmful fluids should be disposed of in accordance with local regulations.

Always use leakproof containers when you drain fluids. Do not pour waste onto the ground, down a drain, or into any source of water.

i07118164

## Burn Prevention

Do not touch any part of an operating engine. Allow the engine to cool before any maintenance is performed on the engine.

### **WARNING**

**Contact with high pressure fuel may cause fluid penetration and burn hazards. High pressure fuel spray may cause a fire hazard. Failure to follow these inspection, maintenance and service instructions may cause personal injury or death.**

After the engine has stopped, you must wait for 60 seconds to allow the fuel pressure to be purged from the high-pressure fuel lines before any service or repair is performed on the engine fuel lines.

Allow the pressure to be purged in the air system, in the hydraulic system, in the lubrication system, or in the cooling system before any lines, fittings, or related items are disconnected.

## Coolant

When the engine is at operating temperature, the engine coolant is hot. The coolant is also under pressure. The radiator and all lines to the heaters or to the engine contain hot coolant.

Any contact with hot coolant or with steam can cause severe burns. Allow cooling system components to cool before the cooling system is drained.

Check that the coolant level after the engine has stopped and the engine has been allowed to cool.

Ensure that the filler cap is cool before removing the filler cap. The filler cap must be cool enough to touch with a bare hand. Remove the filler cap slowly to relieve pressure.

Cooling system conditioner contains alkali. Alkali can cause personal injury. Do not allow alkali to contact the skin, the eyes, or the mouth.

## Oils

Hot oil and hot lubricating components can cause personal injury. Do not allow hot oil to contact the skin. Also, do not allow hot components to contact the skin.

## Diesel Fuel

Diesel may be irritating to the eyes, respiratory system, and skin. Prolonged exposure to diesel may cause various skin conditions. Appropriate personal protective equipment should be used. Refer to supplier Material safety Data sheets for detailed information.

## Viton Seals

### WARNING

**If Viton is burned, a product of this burnt material is an acid which is hazardous. Do not allow burnt material to come into contact with the skin or with the eyes. Use the appropriate set of Personal Protective Equipment to protect your skin and eyes. Failure to follow the instructions or heed the warning could result in serious injury or death.**

If there is need to come into contact with components which have been burnt, ensure that the precautions which follow are used:

- Ensure that the components have cooled.
- Use Neoprene gloves and discard the gloves safely after use.
- Wash the area with calcium hydroxide solution and then with clean water.
- Disposal of components and gloves which are contaminated must be in accordance with local regulations.

If there is contamination of the skin or eyes, wash the affected area with a continuous supply of clean water or with calcium hydroxide solution. Wash the area effected for 15 to 60 minutes and obtain immediate medical attention.

## Batteries

Electrolyte is an acid. Electrolyte can cause personal injury. Do not allow electrolyte to contact the skin or the eyes. Always wear protective glasses for servicing batteries. Wash hands after touching the batteries and connectors. Use of gloves is recommended.

i04823662

## Fire Prevention and Explosion Prevention



Illustration 8

g00704000

All fuels, most lubricants, and some coolant mixtures are flammable.

Flammable fluids that are leaking or spilled onto hot surfaces or onto electrical components can cause a fire. Fire may cause personal injury and property damage.

After the emergency stop button is operated, ensure that you allow 15 minutes, before the engine covers are removed.

Safety Section  
Fire Prevention and Explosion Prevention

---

Determine whether the engine will be operated in an environment that allows combustible gases to be drawn into the air inlet system. These gases could cause the engine to overspeed. Personal injury, property damage, or engine damage could result.

If the application involves the presence of combustible gases, consult your Perkins dealer and/or your Perkins distributor for additional information about suitable protection devices.

Remove all flammable combustible materials or conductive materials such as fuel, oil, and debris from the engine. Do not allow any flammable combustible materials or conductive materials to accumulate on the engine.

Store fuels and lubricants in correctly marked containers away from unauthorized persons. Store oily rags and any flammable materials in protective containers. Do not smoke in areas that are used for storing flammable materials.

Do not expose the engine to any flame.

Exhaust shields (if equipped) protect hot exhaust components from oil or fuel spray in a line, a tube, or a seal failure. Exhaust shields must be installed correctly.

Do not weld on lines or tanks that contain flammable fluids. Do not flame cut lines or tanks that contain flammable fluid. Clean any such lines or tanks thoroughly with a nonflammable solvent prior to welding or flame cutting.

Wiring must be kept in good condition. Ensure that all electrical wires are correctly routed and securely attached. Check all electrical wires daily. Repair any wires that are loose or frayed before you operate the engine. Clean all electrical connections and tighten all electrical connections.

Eliminate all wiring that is unattached or unnecessary. Do not use any wires or cables that are smaller than the recommended gauge. Do not bypass any fuses and/or circuit breakers.

Arcing or sparking could cause a fire. Secure connections, recommended wiring, and correctly maintained battery cables will help to prevent arcing or sparking.

**⚠ WARNING**

**Contact with high pressure fuel may cause fluid penetration and burn hazards. High pressure fuel spray may cause a fire hazard. Failure to follow these inspection, maintenance and service instructions may cause personal injury or death.**

---

After the engine has stopped, wait for 60 seconds in order to allow the fuel pressure to be purged from the high-pressure fuel lines before any service or repair is performed on the engine fuel lines.

Ensure that the engine is stopped. Inspect all lines and hoses for wear or for deterioration. Properly route all hoses. The lines and hoses must have adequate support and secure clamps.

Properly install oil filters and fuel filters. The filter housings must be tightened to the correct torque. Refer to the Disassembly and Assembly manual for more information.

---



Illustration 9

g00704059

Use caution when you are refueling an engine. Do not smoke while you are refueling an engine. Do not refuel an engine near open flames or sparks. Always stop the engine before refueling.

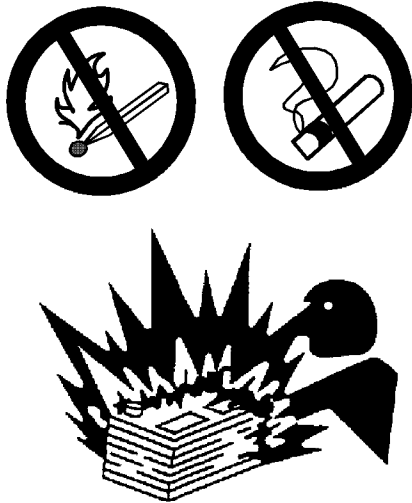

Illustration 10

g02298225

Gases from a battery can explode. Keep any open flames or sparks away from the top of a battery. Do not smoke in battery charging areas.

Never check the battery charge by placing a metal object across the terminal posts. Use a voltmeter or a hydrometer.

Incorrect jumper cable connections can cause an explosion that can result in injury. Refer to the Operation Section of this manual for specific instructions.

Do not charge a frozen battery. Charging a frozen battery may cause an explosion.

The batteries must be kept clean. The covers (if equipped) must be kept on the cells. Use the recommended cables, connections, and battery box covers when the engine is operated.

## Fire Extinguisher

Make sure that a fire extinguisher is available. Be familiar with the operation of the fire extinguisher. Inspect the fire extinguisher and service the fire extinguisher regularly. Obey the recommendations on the instruction plate.

## Lines, Tubes, and Hoses

Do not bend high-pressure lines. Do not strike high-pressure lines. Do not install any lines that are damaged.

Leaks can cause fires. Consult your Perkins dealer or your Perkins distributor for replacement parts.

Replace the parts if any of the following conditions are present:

- High-pressure fuel line or lines are removed.
- End fittings are damaged or leaking.
- Outer coverings are chafed or cut.
- Wires are exposed.
- Outer coverings are ballooning.
- Flexible parts of the hoses are kinked.
- Outer covers have embedded armoring.
- End fittings are displaced.

Make sure that all clamps, guards, and heat shields are installed correctly in order to prevent vibration, rubbing against other parts, and excessive heat.

i08162291

## Crushing Prevention and Cutting Prevention

Support the component properly when work beneath the component is performed.

Unless other maintenance instructions are provided, never attempt adjustments while the engine is running.

Stay clear of all rotating parts and of all moving parts. Leave the guards in place until maintenance is performed. After the maintenance is performed, reinstall the guards.

Keep objects away from moving fan blades. The fan blades will throw objects or cut objects.

When objects are struck, wear protective glasses to avoid injury to the eyes.

Chips or other debris may fly off objects when objects are struck. Before objects are struck, ensure that no one will be injured by flying debris.

i08159517

## Mounting and Dismounting

Inspect the steps, the handholds, and the work area before mounting the engine. Keep these items clean and keep these items in good repair.

Mount the engine and dismount the engine only at locations that have steps and/or handholds. Do not climb on the engine, and do not jump off the engine.

Face the engine to mount the engine or dismount the engine. With your feet and hands, always maintain a three-point contact with the steps and designated handholds. Do not use any controls as handholds.

Do not stand on components which cannot support your weight. Use an adequate ladder or use a work platform. Secure the climbing equipment so that the equipment will not move.

Do not carry tools or supplies when you mount the engine or when you dismount the engine. Use a hand line to raise and lower tools or supplies.

i05874054

## Before Starting Engine

---

### NOTICE

For initial start-up of a new or rebuilt engine, and for start-up of an engine that has been serviced, make provision to shut the engine off should an overspeed occur. This may be accomplished by shutting off the air and/or fuel supply to the engine.

---

### WARNING

**Engine exhaust contains products of combustion which may be harmful to your health. Always start and operate the engine in a well ventilated area and, if in an enclosed area, vent the exhaust to the outside.**

---

Inspect the engine for potential hazards.

Do not start the engine or move any of the controls if there is a "DO NOT OPERATE" warning tag or similar warning tag attached to the start switch or to the controls.

Before starting the engine, ensure that no one is on, underneath, or close to the engine. Ensure that the area is free of personnel.

If equipped, ensure that the lighting system for the engine is suitable for the conditions. Ensure that all lights work properly, if equipped.

All protective guards and all protective covers must be installed if the engine must be started in order to perform service procedures. To help prevent an accident that is caused by parts in rotation, work around the parts carefully.

Do not bypass the automatic shutoff circuits. Do not disable the automatic shutoff circuits. The circuits are provided in order to help prevent personal injury. The circuits are also provided in order to help prevent engine damage.

See the Service Manual for repairs and for adjustments.

i07828827

## Engine Starting

### WARNING

**Do not use aerosol types of starting aids such as ether. Such use could result in an explosion and personal injury.**

---

### WARNING

**Engine exhaust contains products of combustion which may be harmful to your health. Always start and operate the engine in a well ventilated area and, if in an enclosed area, vent the exhaust to the outside.**

---

If a warning tag is attached to the engine start switch or to the controls, DO NOT start the engine or move the controls. Consult with the person that attached the warning tag before the engine is started.

All protective guards and all protective covers must be installed if the engine must be started to perform service procedures. To help prevent an accident that is caused by parts in rotation, work around the parts carefully.

Start the engine from the operator's compartment or from the engine start switch.

Always start the engine according to the procedure that is described in the Operation and Maintenance Manual, "Engine Starting" topic in the Operation Section. Knowing the correct procedure will help to prevent major damage to the engine components. Knowing the procedure will also help to prevent personal injury.

To ensure that the jacket water heater (if equipped) is working correctly, check the water temperature gauge and/or the oil temperature gauge during the heater operation.

**Note:** The engine may be equipped with a device for cold starting. If the engine will be operated in very cold conditions, then an extra cold starting aid may be required. Normally, the engine will be equipped with the correct type of starting aid for your region of operation.

i07668288

## Engine Stopping

- Remove the load in increments.
- Open the circuit breaker.

- Allow the engine to run for five minutes to cool.
- Stop the engine.

Use the Emergency Stop Button (if equipped) **ONLY** in an emergency situation. Do not use the Emergency Stop Button for normal engine stopping. After an emergency stop, **DO NOT** start the engine until the problem that caused the emergency stop has been corrected.

Stop the engine if an overspeed condition occurs during the initial start-up of a new engine or an engine that has been overhauled. This may be accomplished by shutting off the fuel supply to the engine and/or shutting off the air supply to the engine.

To stop an electronically controlled engine, cut the power to the engine.

i02469632

## Electrical System

Never disconnect any charging unit circuit or battery circuit cable from the battery when the charging unit is operating. A spark can cause the combustible gases that are produced by some batteries to ignite.

To help prevent sparks from igniting combustible gases that are produced by some batteries, the negative “-” jump start cable should be connected last from the external power source to the negative “-” terminal of the starting motor. If the starting motor is not equipped with a negative “-” terminal, connect the jump start cable to the engine block.

Check the electrical wires daily for wires that are loose or frayed. Tighten all loose electrical wires before the engine is started. Repair all frayed electrical wires before the engine is started. Refer to the “Engine Starting” section of this Operation and Maintenance Manual for specific starting instructions.

## Grounding Practices

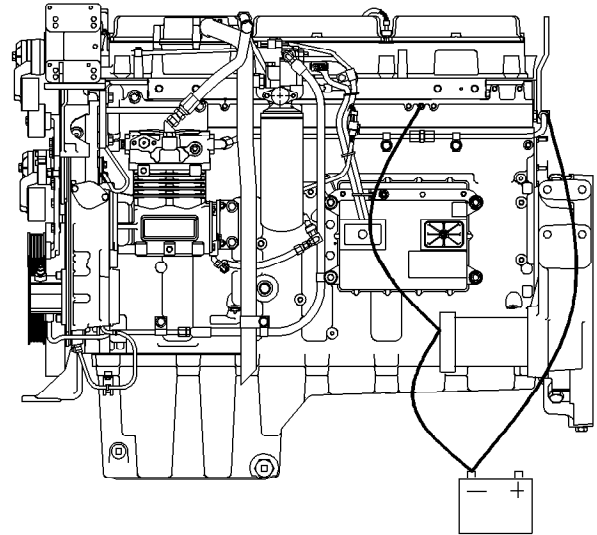

Illustration 11

g00771448

Typical example  
Grounding Stud To Battery Ground

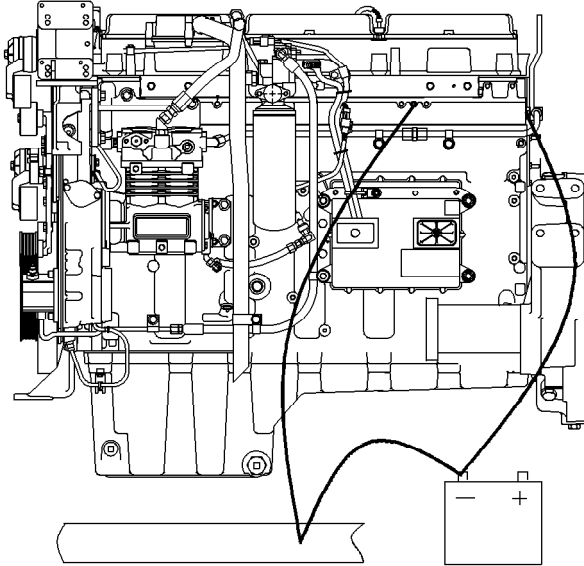

Illustration 12

g00771487

**Typical example****Alternate Grounding Stud To Battery Ground**

Proper grounding for the engine electrical system is necessary for optimum engine performance and reliability. Improper grounding will result in uncontrolled electrical circuit paths and in unreliable electrical circuit paths.

Uncontrolled electrical circuit paths can result in damage to main bearings, to crankshaft bearing journal surfaces, and to aluminum components.

Engines that are installed without engine-to-frame ground straps can be damaged by electrical discharge.

To ensure that the engine and the engine electrical systems function properly, an engine-to-frame ground strap with a direct path to the battery must be used. This path may be provided by way of a starting motor ground, a starting motor ground to the frame, or a direct engine ground to the frame.

All grounds should be tight and free of corrosion. The engine alternator must be grounded to the negative “-” battery terminal with a wire that is adequate to handle the full charging current of the alternator.

i02583382

**Engine Electronics****⚠ WARNING**

**Tampering with the electronic system installation or the OEM wiring installation can be dangerous and could result in personal injury or death and/or engine damage.**

This engine has a comprehensive, programmable Engine Monitoring System. The Engine Control Module (ECM) has the ability to monitor the engine operating conditions. If any of the engine parameters extend outside an allowable range, the ECM will initiate an immediate action.

The following actions are available for engine monitoring control: WARNING, ACTION ALERT and SHUTDOWN.

Many of the parameters that are monitored by the ECM can be programmed for the engine monitoring functions. The following parameters can be monitored as a part of the Engine Monitoring System:

- Atmospheric Pressure
- Inlet Manifold Pressure
- Coolant Temperature
- Engine Oil Pressure
- Crankshaft Position
- Camshaft Position
- Fuel Temperature
- Inlet Manifold Temperature
- System Voltage

The Engine Monitoring package can vary for different engine models and different engine applications. However, the monitoring system and the engine monitoring control will be similar for all engines.



## Product Information Section

### General Information

i01889424

### Welding on Engines with Electronic Controls

#### NOTICE

Proper welding procedures are necessary in order to avoid damage to the engine's ECM, sensors, and associated components. When possible, remove the component from the unit and then weld the component. If removal of the component is not possible, the following procedure must be followed when you weld with a unit that is equipped with an Electronic Engine. The following procedure is considered to be the safest procedure to weld a component. This procedure should provide a minimum risk of damage to electronic components.

#### NOTICE

Do not ground the welder to electrical components such as the ECM or sensors. Improper grounding can cause damage to the drive train bearings, hydraulic components, electrical components, and other components.

Clamp the ground cable from the welder to the component that will be welded. Place the clamp as close as possible to the weld. This will help reduce the possibility of damage.

1. Stop the engine. Turn the switched power to the OFF position.
2. Disconnect the negative battery cable from the battery. If a battery disconnect switch is provided, open the switch.
3. Disconnect the J1/P1 connectors from the ECM. Move the harness to a position that will not allow the harness to accidentally move back and make contact with any of the ECM pins.

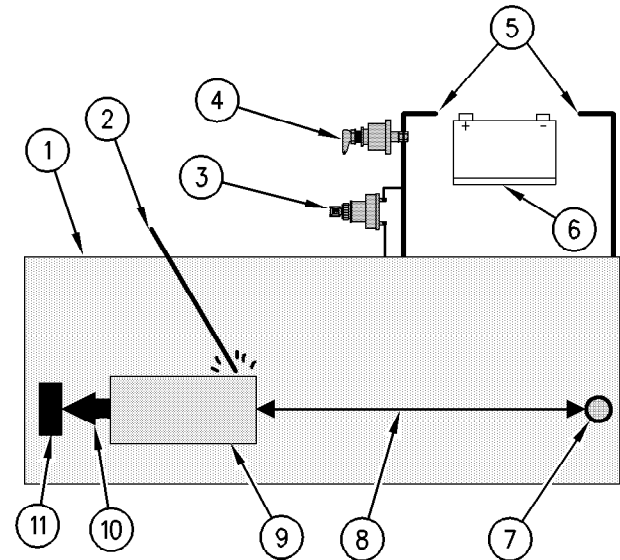

Illustration 13

g00765012

Use the example above. The current flow from the welder to the ground clamp of the welder will not cause damage to any associated components.

- (1) Engine
- (2) Welding rod
- (3) Keyswitch in the OFF position
- (4) Battery disconnect switch in the open position
- (5) Disconnected battery cables
- (6) Battery
- (7) Electrical/Electronic component
- (8) Maximum distance between the component that is being welded and any electrical/electronic component
- (9) The component that is being welded
- (10) Current path of the welder
- (11) Ground clamp for the welder

4. Connect the welding ground cable directly to the part that will be welded. Place the ground cable as close as possible to the weld in order to reduce the possibility of welding current damage to bearings, hydraulic components, electrical components, and ground straps.

**Note:** If electrical/electronic components are used as a ground for the welder, or electrical/electronic components are located between the welder ground and the weld, current flow from the welder could severely damage the component.

5. Protect the wiring harness from welding debris and spatter.
6. Use standard welding practices to weld the materials.

## Model Views

i02572859

### Model View Illustrations

The following model views show the 2506 Engine features. Due to individual applications, your engine may appear different from the illustrations.

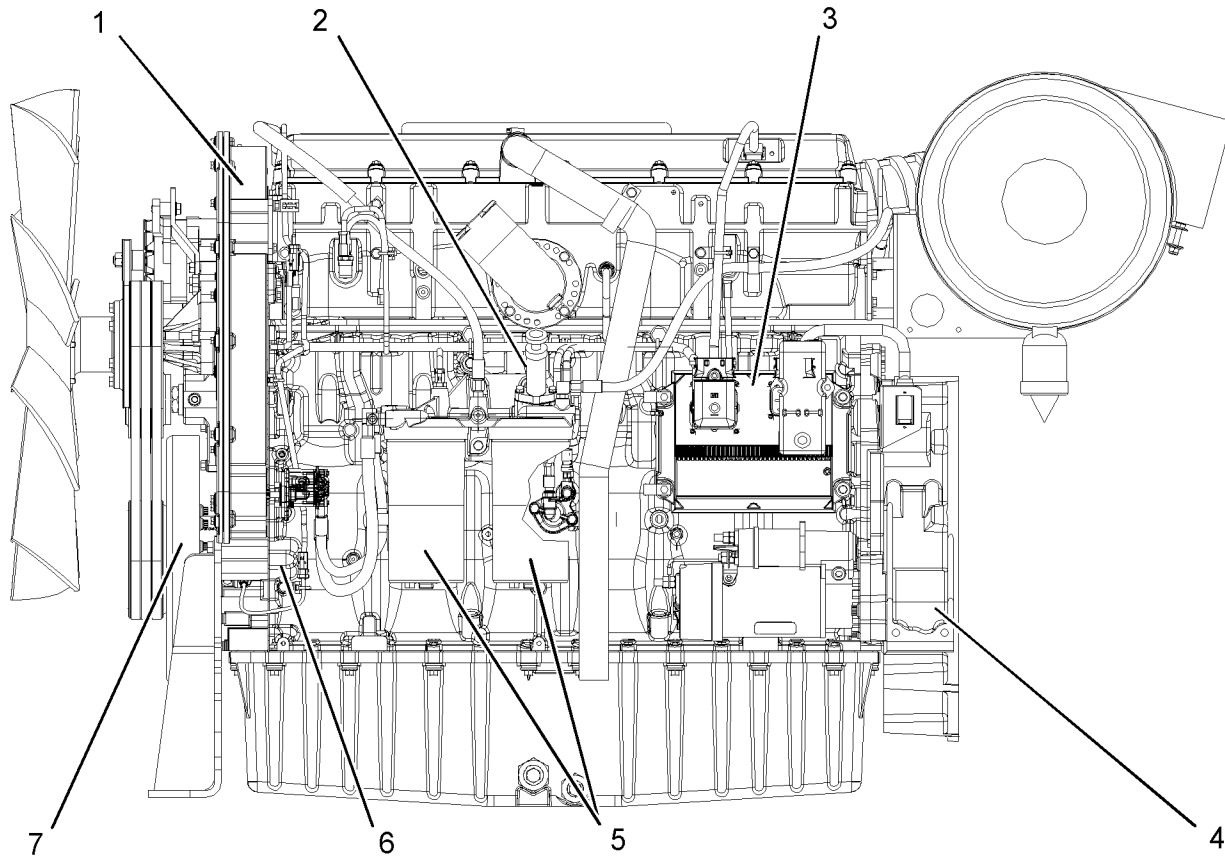

Illustration 14

g01289036

Typical example

Left side view

(1) Front timing gear housing

(2) Fuel priming pump

(3) Electronic Control Module (ECM)

(4) Flywheel housing

(5) Fuel filters

(6) Fuel transfer pump

(7) Vibration Damper

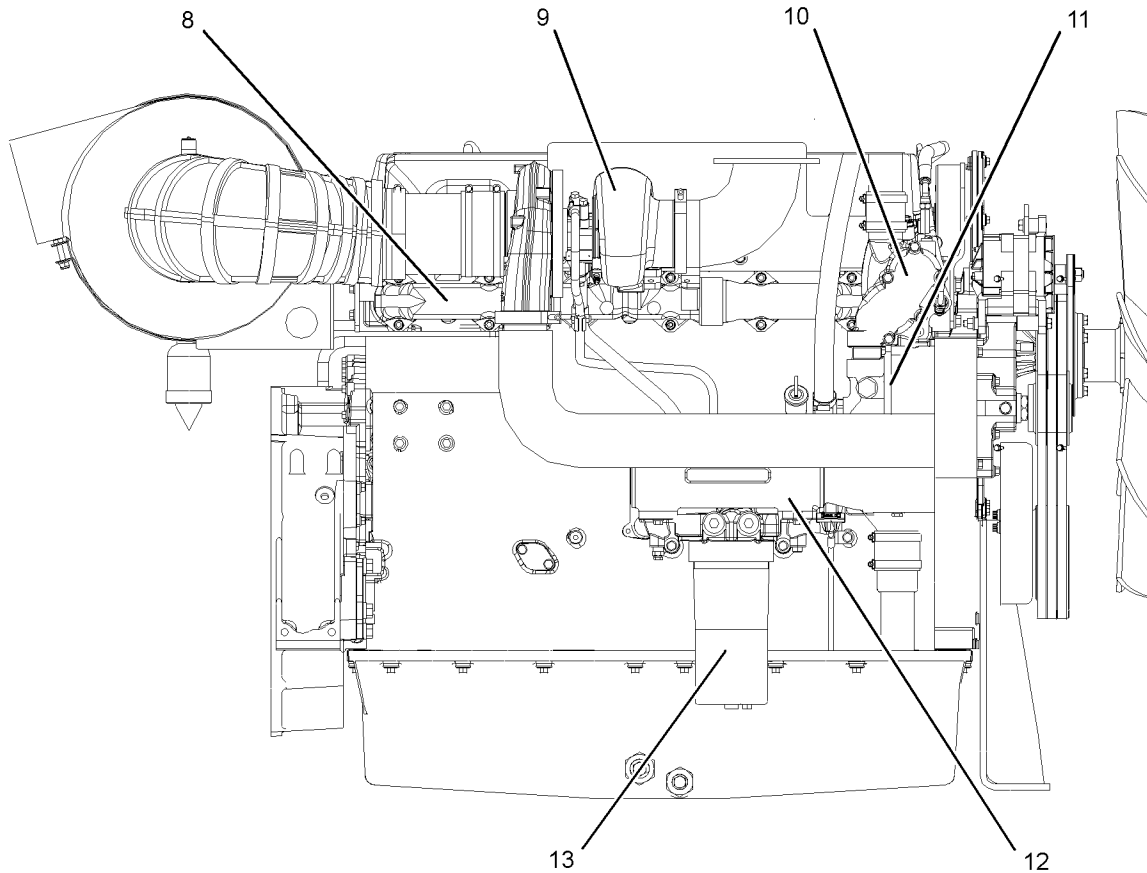

Illustration 15

g01289038

Typical example  
Right side view

(8) Exhaust manifold  
(9) Turbocharger

(10) Temperature regulator housing  
(11) Water pump

(12) Oil cooler  
(13) Oil filter

i02581540

## Engine Description

Table 1

| 2506 Engine Specifications |                               |
|----------------------------|-------------------------------|
| Cylinders and Arrangement  | In-line six cylinder          |
| Bore                       | 137.2 mm (5.4 inch)           |
| Stroke                     | 171.5 mm (6.8 inch)           |
| Displacement               | 15.2 L (928 in <sup>3</sup> ) |
| Firing Order               | 1-5-3-6-2-4                   |
| Rotation (flywheel end)    | Counterclockwise              |

The electronic engines that are covered by this manual have the following characteristics: direct fuel injection, electronic unit injection that is mechanically actuated, turbocharged and air-to-air aftercooled (ATAAC).

The electronic engine control system provides the following functions: electronic governing, automatic air to fuel ratio control, injection timing control and system diagnostics.

An electronic governor controls the output of the unit injectors in order to maintain the engine rpm that is desired.

Very high injection pressures are produced by electronically controlled, mechanically actuated unit injectors. The injectors combine the pumping and the electronic fuel metering (duration and timing) during injection. The unit injectors accurately control smoke limiting, white smoke, and engine acceleration rates.

There is one unit injector per cylinder. Individual unit injectors meter the fuel. The individual unit injectors also pump the fuel. The metering and the pumping is done under high pressure. High injection pressures help to reduce fuel consumption and emissions. The use of this type of unit injector provides total electronic control of injection timing. The injection timing varies with engine operating conditions. The engine performance is optimized in the following areas:

- Starting
- Emissions
- Noise
- Fuel consumption

The timing advance is achieved through precise control of the injector firing. Engine speed is controlled by adjusting the firing duration. The information is provided to the Electronic Control Module (ECM) by the crankshaft position sensor and the camshaft position sensor. The information is for detection of cylinder position and engine speed.

The engines have built-in diagnostics in order to ensure that all of the components are functioning and operating properly. In the event of a system component deviation from the programmed limits, the operator will be alerted to the condition by a DIAGNOSTIC lamp that is mounted on the control panel. An electronic service tool that is provided by Perkins may be used to read the numerical code of the diagnostic flash code. There are three types of diagnostic codes: ACTIVE, LOGGED and EVENT. These codes are logged and stored in the ECM. Refer to Operation and Maintenance Manual, "Engine Diagnostics" for additional information.

The cooling system consists of the following items: a centrifugal pump that is driven by a gear, water temperature regulator, an oil cooler and a radiator that incorporates a shunt system.

The engine lubricating oil is supplied by a gear type pump. The engine lubricating oil is cooled and filtered. Bypass valves provide unrestricted flow of lubrication oil to the engine parts when the oil viscosity is high or if either the oil cooler or the oil filter elements (paper cartridge) become plugged.

Engine efficiency, efficiency of emission controls, and engine performance depend on adherence to proper operation and maintenance recommendations. This includes the use of recommended fuels, coolants and lubrication oils.

## Aftermarket Products and Perkins Engines

When auxiliary devices, accessories, or consumables (filters, additives, catalysts, etc) which are made by other manufacturers are used on Perkins products, the Perkins warranty is not affected simply because of such use.

**However, failures that result from the installation or use of other manufacturers' devices, accessories, or consumables are NOT Perkins defects. Therefore, the defects are NOT covered under the Perkins warranty.**

# Product Identification Information

i02578572

## Plate Locations and Film Locations

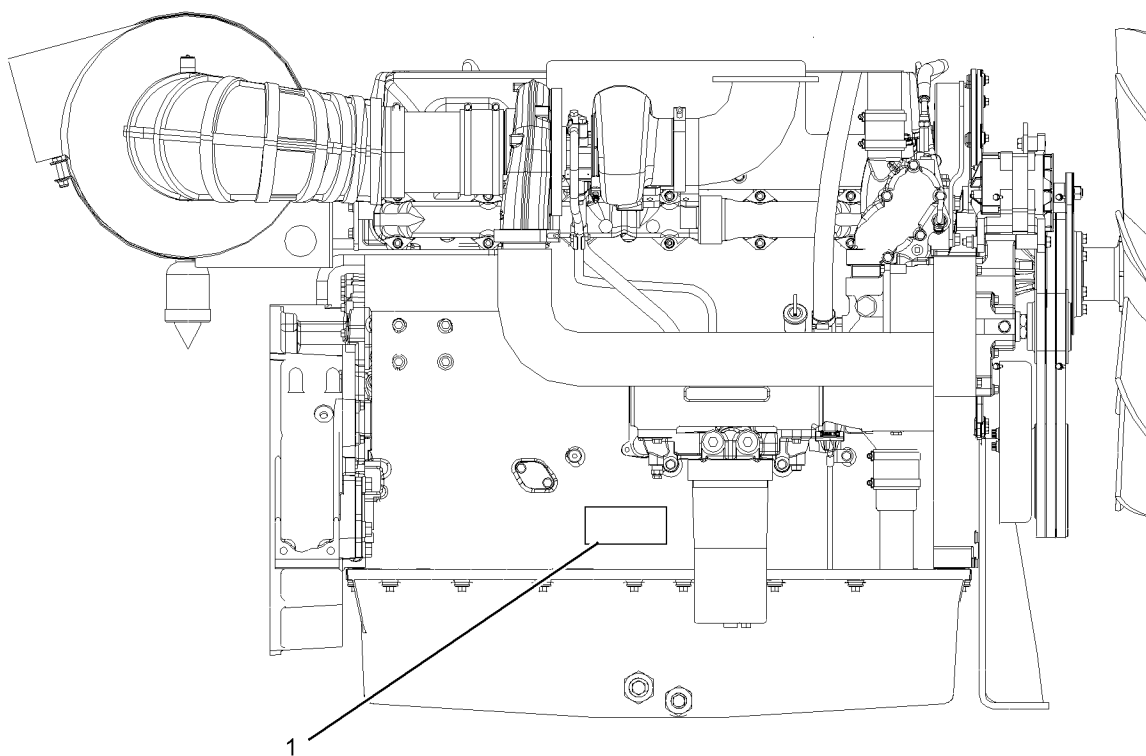

Illustration 16

g01291895

(1) Serial number plate

Perkins engines are identified by serial numbers. These numbers are shown on the engine serial number plate. Perkins distributors need these numbers in order to determine the components that were included with the engine. This permits accurate identification of replacement part numbers.

Engine serial number \_\_\_\_\_

Designation \_\_\_\_\_

### Serial Number Plate (1)

The engine serial number plate is located on the lower right side of the engine block.

Engine Rating \_\_\_\_\_

i02563635

## Reference Numbers

Information for the following items may be needed to order parts. Locate the information for your engine. Record the information in the appropriate space. Make a copy of this list for a record. Keep the information for future reference.

### Record for Reference

Engine Model \_\_\_\_\_

Engine Serial number \_\_\_\_\_

Engine rpm \_\_\_\_\_

Primary Fuel Filter \_\_\_\_\_

Secondary Fuel Filter Element \_\_\_\_\_

Lubrication Oil Filter Element \_\_\_\_\_

Total Lubrication System Capacity \_\_\_\_\_

Total Cooling System Capacity \_\_\_\_\_

Air Cleaner Element \_\_\_\_\_

Fan Drive Belt \_\_\_\_\_

Alternator Belt \_\_\_\_\_

i02576079

## Emissions Certification Film

### Label for compliant engines

|                                                                                                                                                                                                                                                                                       |                                                          |
|---------------------------------------------------------------------------------------------------------------------------------------------------------------------------------------------------------------------------------------------------------------------------------------|----------------------------------------------------------|
|  <b>IMPORTANT ENGINE INFORMATION</b>                                                                                                                                                                 |                                                          |
| Engine Family: *****                                                                                                                                                                                                                                                                  | Initial Injection Timing : Electronic                    |
| Engine Type: 2506C-TAG1                                                                                                                                                                                                                                                               | Max Fuel Rate • Max Power : 000 mm <sup>3</sup> / Stroke |
|                                                                                                                                                                                                                                                                                       | Displacement: ### Litres                                 |
| Max Advertised Power: ####kW @ #### rpm                                                                                                                                                                                                                                               |                                                          |
| Emissions Control System: DDI, ECM, TAA                                                                                                                                                                                                                                               |                                                          |
| Valve Lash: Inlet - ####mm Exhaust - ####mm                                                                                                                                                                                                                                           |                                                          |
| Settings are to be made with engine at normal operating temperature.<br>This engine conforms to EU ***** regulations for large non road and off-road compression ignition engines, constant speed only.<br>This engine is certified to operate on commercially available diesel fuel. |                                                          |

Illustration 17

g01290846

Typical example of a label that is installed on engines that comply with emissions

|                                                                                                                                                                                                                                                                                           |                                                          |
|-------------------------------------------------------------------------------------------------------------------------------------------------------------------------------------------------------------------------------------------------------------------------------------------|----------------------------------------------------------|
|  <b>IMPORTANT ENGINE INFORMATION</b>                                                                                                                                                                     |                                                          |
| Engine Family: #####                                                                                                                                                                                                                                                                      | Initial Injection Timing : Electronic                    |
| Engine Type: 2506D-E15TAG1                                                                                                                                                                                                                                                                | Max Fuel Rate • Max Power : 000 mm <sup>3</sup> / Stroke |
|                                                                                                                                                                                                                                                                                           | Displacement: ### Litres                                 |
| Max Advertised Power: ###kW @ 1800 rpm                                                                                                                                                                                                                                                    |                                                          |
| Emissions Control System: DDI, ECM, TAA                                                                                                                                                                                                                                                   |                                                          |
| Valve Lash: Inlet - ###mm Exhaust - ###mm                                                                                                                                                                                                                                                 |                                                          |
| Settings are to be made with engine at normal operating temperature.<br>This engine conforms to 2006 U.S EPA regulations for large non road and off-road compression ignition engines, constant speed only.<br>This engine is certified to operate on commercially available diesel fuel. |                                                          |

Illustration 18

g01290859

Typical example of a label that is installed on engines that comply with emissions

i02566844

## Customer Specified Parameters

To record programmed specifications, use the following blanks.

**Customer Passwords** (If required).

- First Password \_\_\_\_\_
- Second Password \_\_\_\_\_

**Rating Selection (L-N)** \_\_\_\_\_

**Equipment ID** \_\_\_\_\_

## Programmable Monitoring System (PMS)

The Programmable Monitoring System determines the level of action that is taken by the ECM in response to a condition that can damage the engine. These conditions are identified by the ECM from the signals that are produced from the following sensors.

- Inlet Manifold Temperature Sensor

- Coolant Temperature Sensor
- Engine Oil Pressure Sensor
- Engine Crankshaft/Camshaft Sensors
- Inlet Manifold Pressure Sensor
- Fuel Temperature Sensor



Table 2

| Event Code  | Parameter                                          | State     | Trip Point         | Delay Time |
|-------------|----------------------------------------------------|-----------|--------------------|------------|
| <b>E162</b> | <b>High Boost Pressure</b>                         |           |                    |            |
| -1          | Warn Operator (1)                                  | On        | 300 kPa (43.5 psi) | 30 seconds |
| -2          | Action Alert (2)                                   | Always On | None               | 5 seconds  |
| <b>E360</b> | <b>Low Engine Oil Pressure</b>                     |           |                    |            |
| -1          | Warn Operator (1)                                  | On        | 300 kPa (43.5 psi) | 60 seconds |
| -2          | Action Alert (2)                                   | Always On | None               | 2 seconds  |
| -3          | Engine Shutdown (3)                                | Always On | None               | 2 seconds  |
| <b>E361</b> | <b>High Engine Coolant Temperature</b>             |           |                    |            |
| -1          | Warn Operator (1)                                  | On        | 104 °C (2190 °F)   | 60 seconds |
| -2          | Action Alert (2)                                   | Always On | 105 °C (221 °F)    | 10 seconds |
| -3          | Engine Shutdown (3)                                | Always On | 108 °C (226 °F)    | 10 seconds |
| <b>E362</b> | <b>Engine Overspeed</b>                            |           |                    |            |
| -1          | Warn Operator (1)                                  | On        | 2000 RPM           | 1 second   |
| -2          | Action Alert (2)                                   | Always On | 2050 RPM           | 1 second   |
| -3          | Engine Shutdown (3)                                | Always On | 2140 RPM           | 0 second   |
| <b>E363</b> | <b>High Fuel Supply Temperature</b>                |           |                    |            |
| -1          | Warn Operator (1)                                  | On        | 60 °C (140 °F)     | 60 seconds |
| -2          | Action Alert (2)                                   | Always On | 68 °C (154 °F)     | 60 seconds |
| <b>E368</b> | <b>High Engine Intake Manifold Air Temperature</b> |           |                    |            |
| -1          | Warn Operator (1)                                  | On        | 75 °C (167 °F)     | 60 seconds |
| -2          | Action Alert (2)                                   | Always On | 78 °C (172 °F)     | 10 seconds |

Refer to Troubleshooting , “System Configuration Parameters” for additional information for the Programmable Monitoring System.

## Operation Section

i04823376

## Lifting and Storage

i07444135

## Product Lifting

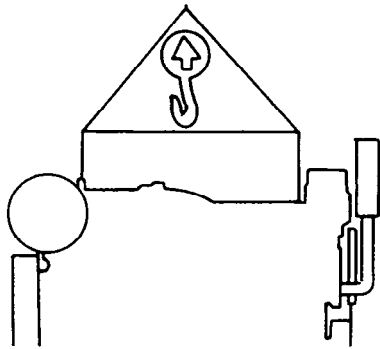

Illustration 19

g00103219

### NOTICE

Always inspect lifting eyebolts and all other lifting equipment for damage before performing any lifting. Never Bend the eyebolts and the brackets. Never perform product lifting if the components are damaged. Remember that the capacity of an eyebolt is less as the angle between the supporting members and the object becomes less than 90 degrees.

When it is necessary to remove a component at an angle, only use a link bracket that is properly rated for the weight.

Use a hoist to remove heavy components. Use an adjustable lifting beam to lift the engine. All supporting members (chains and cables) should be parallel to each other. The chains and cables should be perpendicular to the top of the object that is being lifted.

Some removals require lifting the fixtures to obtain proper balance and safety.

To remove the engine ONLY, use the lifting eyes that are on the engine.

Lifting eyes are designed and installed for specific engine arrangements. Alterations to the lifting eyes and/or the engine make the lifting eyes and the lifting fixtures obsolete. If alterations are made, ensure that proper lifting devices are provided. Consult your Perkins dealer for information regarding fixtures for proper engine lifting.

## Product Storage

Refer to Perkins Engine Company limited, Stafford for information on engine storage.

There are three different levels of engine storage. Level "A, B and C" .

### Level "A "

Level "A" will give protection for 12 month for diesel engines and 12 month protection for gas engines. This level is for engines that are transported by a container or a truck. Level "A" is for the transportation of items that are within the United kingdom and within Europe.

### Level "B "

This level is additional to level "A" . Level "B" will give protection under normal storage condition from  $-15^{\circ}$  to  $+55^{\circ}\text{C}$  ( $5^{\circ}$  to  $99^{\circ}\text{F}$ ) and "90%" relative humidity for 2 year. Level "B" is for the transportation of items overseas.

### Level "C "

In order to protect the product to Level "C" , contact Perkins Engines Company Limited Stafford.

# Gauges and Indicators

i02576034

## Gauges and Indicators

Your engine may not have the same gauges or all of the gauges that are described. For more information about the gauge package, see the OEM information.

Gauges provide indications of engine performance. Ensure that the gauges are in good working order. Determine the normal operating range by observing the gauges over a period of time.

Noticeable changes in gauge readings indicate potential gauge or engine problems. Problems may also be indicated by gauge readings that change even if the readings are within specifications. Determine and correct the cause of any significant change in the readings. Consult your Perkins dealer or your Perkins distributor for assistance.

---

### NOTICE

If no oil pressure is indicated, STOP the engine. If maximum coolant temperature is exceeded, STOP the engine. Engine damage can result.

---



**Engine Oil Pressure – The range for the engine oil pressure is 420 kPa (61 psi).**



**Jacket Water Coolant Temperature – Typical water temperature into the engine is 88 °C (190 °F). Higher temperatures may occur under certain conditions. The water temperature reading may vary according to load. The reading should never exceed 107 °C (224 °F).**

1. A high water temperature switch is installed in the cooling system.



**Tachometer – This gauge indicates engine speed (rpm).**



**Ammeter – This gauge indicates the amount of charge or discharge in the battery charging circuit. Operation of the indicator should be to the right side of “0” (zero).**



**Service Hour Meter – The gauge indicates operating hours of the engine.**

## Features and Controls

i02564764

### Monitoring System

The engine has protection in three stages:

- Warning
- Action Alert
- Shutdown

The engine protection may be overridden by the critical condition mode.

All alarms and shutdown faults are transmitted via the Perkins Data Link. The Electronic Control Module (ECM) monitors the following parameters:

- Engine Temperatures
- Engine Pressures
- Engine Speed

If the parameters exceed a trip point for a period of time that is longer than the delay period, the ECM logs an event code and the indicator switches ON.

The following parameters are monitored for event codes:

- Lubricating Oil Pressure
- Coolant Temperature
- Overspeed
- Inlet Manifold Air Temperature
- Inlet Manifold Pressure
- Fuel Temperature

The temperature protection is disabled for a period of time when the engine is cranking in order to compensate for heat soak solutions.

If a Warning Action Alert, or Shutdown output for either the lubricating oil pressure, coolant temperature or overspeed fault conditions, the ECM switches on the dedicated alarm output.

If the engine is in a Warning condition and the fault deteriorates further to the shutdown limit then the ECM logs the fault. The ECM then shuts down the engine. If the engine shuts down on oil pressure, coolant temperature or overspeed the respective alarm output will be energized.

### Warning Alarm

The Warning alarm informs the user that the engine is approaching a critical condition.

If the engine is in the Warning condition, then the event will be logged in the memory of the ECM. A fault code will be transmitted over the Perkins Data link and the hard wired Warning output will be energized. If the engine is in the Warning condition, the fault code and output will remain while the condition exists. The electronic service tool is used to remove the fault code from the memory of the ECM. The trip point for the Warning alarm will be set to a factory default in production. The electronic service tool may be used to alter the trip point for a Warning within predefined limits.

### Action Alert

The Action Alert informs the OEM that the engine is approaching a critical condition. The engine should be stopped in a controlled manner or the load on the engine is reduced. Further running of the engine may result in an immediate shutdown.

If the engine is in the Action Alert condition, the event will be logged in the memory of the ECM. A fault code will be transmitted over the Perkins Data link and the hard wired Action Alert will be energized. If the engine is in the Action Alert condition the fault code and output will remain while the condition exists. The fault will remain in the memory of the ECM.

### Shutdown

If the engine parameter reaches the Shutdown condition, the following faults may occur: lubricating oil pressure, coolant temperature or overspeed. The event will be logged in the memory of the ECM. The engine will be shut down. A fault code will be transmitted over the Perkins Data link and the hard wired Shutdown output will be energized. The Shutdown condition will latch until the ECM is reset.

### Critical Protection Override

If the engine is in an application that is critical for safety, the protection system can be overridden in order to ensure the continuation of the power supply during engine fault conditions.

Critical Protection Override will be set by a switch input from the OEM. For example, this may be a switch to battery + in order to disable a critical override. Critical Protection Override input can be enabled in the electronic service tool by use of a factory password.

When the Critical Protection Override is activated, the ECM will log the condition. The engine will continue to run the engine in all fault conditions with the exception of Overspeed shutdown and Emergency shutdown. If the engine enters a fault condition the ECM will log the event in memory. The ECM will record the number of faults that are overridden. When the Critical Protection Override is activated, the ECM will energize the Warning, Action Alert and the Shutdown outputs, as required.

It is not possible to clear logged shutdown events from the logged events screen which occur when the ECM is operating in Critical Protection Override mode.

**Note:**

If the engine is operated with an active fault and in Critical Protection Override mode, the engine warranty will become invalid. When the engine is operated in Critical Protection Override mode, the oil pressure and the coolant temperature events will be displayed in the "critical events" screen of the electronic service tool.

## Standard Warning Outputs

The ECM provides individual outputs in order to drive warning lamps or relays to indicate each of the following fault conditions:

- Diagnostic Fault
- Oil Pressure
- Coolant Temperature
- Overspeed
- Action Alert
- Warning
- Shutdown

If the ECM detects a warning for the coolant temperature, the output on the coolant temperature will be energized and the warning output will be energized. If the ECM detects a warning for the low oil pressure, the output on the oil pressure will be energized and the warning output will be energized.

If the Action Alert alarms are enabled and the ECM detects a coolant temperature condition, the output on the coolant Temperature will be energized and the output on the Action Alert will be energized.

If the engine shuts down on low oil pressure the output on the low oil pressure will be energized and the output on the shutdown will be energized. If the engine shuts down on coolant temperature or the engine shuts down on overspeed the dedicated output and the shutdown output will be energized.

## Shutdown Reset

After an engine shutdown, the fault can be cleared by operating the reset input of the shutdown or powering down the controller.

Powering down the electronic control module can be achieved by the operation of the keyswitch into sleep mode. The electronic control module can be powered down by isolating the power supply to the electronic control module.

**Note:** It is not possible to reset the ECM by using the Reset input until the engine has come to rest.

## Altitude derate

At high altitudes or high ambient temperatures, the engine will not be derated. The engine derate information can be obtained from the Applications Department at Perkins Engines Company Limited Stafford. These limits for the derate must be observed or severe engine damage may occur.

**Note:** There is no provision to manually derate the engine. When the engine is operating at a high altitude, the power output requires reducing by the operator. There is not an adjustment to the engine.

## Diagnostic

If there is a fault with the engine protection sensor on the engine, the engine activates a diagnostic code. The engine communicates the diagnostic code to the operator via the Diagnostic output. The diagnostic code provides an indication to the operator of a fault with the engine protection system. Running of the engine for a prolonged period in this condition may result in engine failure. The output is generally used to drive lamps or relays.

The following sensors are monitored in order to determine if the sensors are out of the normal range, an open circuit or a short circuit:

- Lubricating Oil Pressure
- Inlet Manifold Pressure
- Inlet Manifold Temperature
- Fuel Temperature
- Coolant Temperature
- Engine Speed

- Desired Speed Input

The Diagnostic output differs from the Warning and Shutdown outputs. The outputs refer to the operation of the engine. The Diagnostic output refers to the condition of the electronic system and software system.

A diagnostic fault may develop on the lubricating oil pressure or coolant temperature sensors. For example, if a Shutdown protection sensor has a fault, this will result in an engine shutdown, unless the system is in critical protection override. If a diagnostic fault occurs with one of the engine speed sensors while the engine is running. The engine continues to run by using the other timing sensor for reference.

i02572884

## Sensors and Electrical Components

### Sensor Locations

Illustration 20 shows the typical locations of the sensors on the engine. Specific engines may appear different from the illustration due to differences in applications.

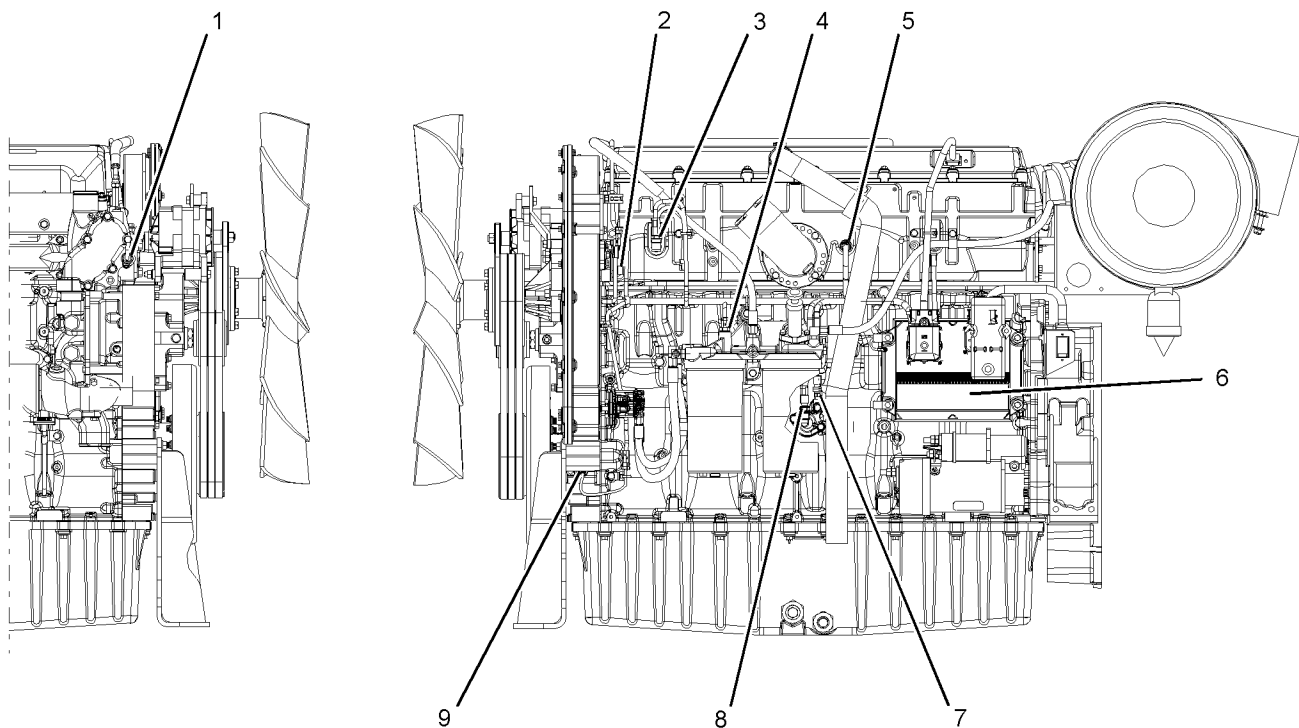

Illustration 20

g01279775

(1) Engine coolant temperature sensor  
(2) Camshaft position sensor  
(3) Inlet manifold pressure sensor

(4) Fuel temperature sensor  
(5) Inlet manifold temperature sensor  
(6) Electronic control module (ECM)

(7) Engine oil pressure sensor  
(8) Atmospheric pressure sensor  
(9) Crankshaft position sensor

## Failure of Sensors

### All Sensors

A failure of any of the sensors may be caused by one of the following malfunctions:

- Sensor output is open.
- Sensor output is shorted to “- battery” or “+ battery” .
- Measured reading of the sensor is out of the specification.

## Programmable Monitoring System (PMS)

The Programmable Monitoring System determines the level of action that is taken by the Engine Control Module (ECM) in response to a condition that can damage the engine. These conditions are identified by the ECM from the signals that are produced from the following sensors.

### Engine Coolant Temperature Sensor 1

The coolant temperature sensor monitors engine coolant temperature. The output of the ECM can indicate a high coolant temperature through a relay or a lamp. The coolant temperature sensor is used by the ECM to determine initiation of the Cold Start Condition.

### Failure of the Coolant Temperature Sensor

The ECM will detect a failure of the coolant temperature sensor. The diagnostic lamp will warn the operator about the status of the coolant temperature sensor. A failure of the coolant temperature sensor will cause a shutdown of the engine. The faulty sensor should be replaced. Refer to Disassembly and Assembly Manual, “Coolant Temperature Sensor - Remove and Install”.

### Inlet Manifold Pressure Sensor 3

The inlet manifold pressure sensor measures boost pressure in the inlet air manifold. A signal is sent to the ECM. A failure of the inlet manifold pressure sensor will limit the power of the engine.

### Inlet Manifold Temperature Sensor 5

The inlet manifold temperature sensor measures the inlet air temperature. A signal is sent to the ECM. The inlet air temperature sensor is also used by the ECM to determine initiation of the Cold Start Strategy.

### Engine Oil Pressure Sensor 7

The engine oil pressure sensor is an absolute pressure sensor that measures the engine oil pressure in the main oil gallery. The engine oil pressure sensor detects engine oil pressure for diagnostic purposes. The engine oil pressure sensor sends a signal to the ECM .

### Low Oil Pressure Warning

The setpoint for the low pressure warning is dependent upon the engine speed. The fault will be active and logged only if the engine has been running for more than 8 seconds.

### Low Oil Pressure

The very low oil pressure setpoint is dependent upon the engine speed. If very low oil pressure is detected, the ECM will stop the engine immediately unless Critical Events Override is active.

## **Failure of the Engine Oil Pressure Sensor**

The ECM will detect failure of the engine oil pressure sensor. The diagnostic lamp warns the user about the status of the engine oil pressure sensor. The engine oil pressure related strategies will be disabled in the event of a failure of the engine oil pressure sensor. A failure of the engine oil pressure sensor will cause a shutdown of the engine. The faulty sensor should be replaced. Refer to Disassembly and assembly Manual, "Engine Oil Pressure Sensor - Remove and Install".

## **Crankshaft Position Sensor 9**

If the ECM does not receive a signal from the crankshaft position sensor, the "DIAGNOSTIC" lamp will indicate a diagnostic fault code which will be logged in the ECM memory.

If the ECM does not receive a signal from the crankshaft position sensor (9), the ECM will read the signal from the camshaft position sensor (2). The ECM continually checks in order to determine if there is a signal from both sensors. If either sensor fails, the faulty sensor should be replaced. Refer to Disassembly and Assembly Manual, "Crankshaft Position Sensor - Remove and Install" or refer to Disassembly and Assembly Manual, "Camshaft Position Sensor - Remove and Install".

Intermittent failure of the sensors will cause erratic engine control.



# Engine Diagnostics

i02566845

## Self-Diagnostics

i00863835

The electronic control module has some self-diagnostic ability. When an electronic problem with an input or an output is detected, a diagnostic code is generated. This indicates the specific problem with the circuitry.

Diagnostic codes are also generated when an abnormal engine operating condition is detected. For example, a diagnostic code will be generated if the low oil pressure alarm is activated. In this case, the diagnostic code indicates the symptom of a problem. This type of diagnostic code is called an event. An event is triggered by the detection of an abnormal engine operating condition.

A diagnostic code which represents a problem that currently exists is called an active code.

A diagnostic code that is stored in memory is called a logged code. Always service active codes prior to servicing logged codes. Logged codes may include the following categories:

- Intermittent problems
- Recorded events
- Performance history

Logged codes may not indicate that a repair is needed. The problems may have been repaired since the logging of the code. Logged codes may be helpful to troubleshoot intermittent problems.

i02572812

## Diagnostic Lamp

The "DIAGNOSTIC" lamp is used to indicate the existence of an active fault.

A fault diagnostic code will remain active until the problem is repaired.

## Fault Logging

The system provides the capability of Fault Logging. When the Electronic Control Module (ECM) generates an active diagnostic code, the code will be logged in the memory of the ECM. The Perkins electronic service tool can retrieve codes that have been logged. The codes that have been logged can be cleared with the Perkins electronic service tool. The codes that have been logged in the memory of the ECM will be automatically cleared from the memory after 100 hours. The following faults can not be cleared from the memory of the ECM without using a factory password: overspeed, low engine oil pressure and high engine coolant temperature.

i02651197

## Engine Operation with Active Diagnostic Codes

If a diagnostic lamp illuminates during normal engine operation, the system has identified a situation that is not within the specification. Use the electronic service tool to check the active diagnostic codes.

The active diagnostic code should be investigated. The cause of the problem should be corrected as soon as possible. If the cause of the active diagnostic code is repaired and there is only one active diagnostic code, the diagnostic lamp will turn off.

Operation of the engine and performance of the engine can be limited as a result of the active diagnostic code that is generated. Acceleration rates may be significantly slower and power outputs may be automatically reduced. Refer to Troubleshooting , "Troubleshooting with a Diagnostic Code" for more information on the relationship between each active diagnostic code and the possible effect on engine performance.

i02572847

## Engine Operation with Intermittent Diagnostic Codes

If a diagnostic lamp illuminates during normal engine operation and the diagnostic lamp shuts OFF, an intermittent fault may have occurred. If a fault has occurred, the fault will be logged into the memory of the Electronic Control Module (ECM).

Operation Section  
Engine Operation with Intermittent Diagnostic Codes

---

In most cases, it is not necessary to stop the engine because of an intermittent code. However, the operator should retrieve the logged fault codes and the operator should reference the appropriate information in order to identify the nature of the event. The operator should log any observation that could have caused the lamp to light.

- Low power
- Limits of the engine speed
- Excessive smoke, etc

This information can be useful to help troubleshoot the situation. The information can also be used for future reference. For more information on diagnostic codes, refer to the Troubleshooting guide for this engine.

# Engine Starting

i02566884

## Before Starting Engine

Before the engine is started, perform the required daily maintenance and any other periodic maintenance that is due. Refer to the Operation and Maintenance Manual, "Maintenance Interval Schedule" for more information.

- Open the fuel supply valve (if equipped).

### NOTICE

All valves in the fuel return line must be open before and during engine operation to help prevent high fuel pressure. High fuel pressure may cause filter housing failure or other damage.

If the engine has not been started for several weeks, fuel may have drained from the fuel system. Air may have entered the filter housing. Also, when fuel filters have been changed, some air pockets will be trapped in the engine. In these instances, prime the fuel system. Refer to the Operation and Maintenance Manual, "Fuel System - Prime" for more information on priming the fuel system.

### WARNING

**Engine exhaust contains products of combustion which may be harmful to your health. Always start and operate the engine in a well ventilated area and, if in an enclosed area, vent the exhaust to the outside.**

- Do not start the engine or move any of the controls if there is a "DO NOT OPERATE" warning tag or similar warning tag attached to the start switch or to the controls.
- Reset all of the shutoffs or alarm components (if equipped).
- Ensure that any equipment that is driven by the engine has been disengaged from the engine. Minimize electrical loads or remove any electrical loads.

i02583442

## Starting the Engine

**Note:** Do not adjust the engine speed control during start-up. The electronic control module (ECM) will control the engine speed during start-up.

## New engines

Prime the turbocharger. This can be achieved by cranking the engine briefly with no fuel.

If necessary, stop a new engine if an overspeed condition occurs. If necessary, press the Emergency Stop button.

## Starting the Engine

1. Move the ignition switch to the ON position. If a system fault is indicated, investigate the cause. If necessary, use the Perkins electronic service tool.
2. Push the start button or turn the keyswitch to the START position in order to crank the engine.
3. If the engine fails to start within 30 seconds, release the start button or the ignition switch. Wait for 30 seconds in order to allow the starting motor to cool before attempting to start the engine again.

**Note:** A system fault may be indicated after the engine is started. If this occurs the ECM has detected a problem with the system. If necessary, use the Perkins Service Tool to investigate the problem.

**Note:** Oil pressure should rise within 15 seconds after the engine starts. The engine electronic controls monitor the engine oil pressure. The electronic controls will stop the engine if the oil pressure is below normal.

4. When possible, allow the engine to run at no load for approximately three minutes. Run the engine at no load until the water temperature gauge has started to rise. Check all gauges during the warm-up period.

i07772200

## Cold Weather Starting

### WARNING

**Do not use aerosol types of starting aids such as ether. Such use could result in an explosion and personal injury.**

The engine will start at a temperature of  $-10^{\circ}\text{C}$  ( $14^{\circ}\text{F}$ ). The ability to start at temperatures below  $10^{\circ}\text{C}$  ( $50^{\circ}\text{F}$ ) will improve by the use of a cylinder block coolant heater or a device which heats the crankcase oil. This will help to reduce white smoke and misfires when the engine is started in cold weather.

## Operation Section

### Starting with Jump Start Cables

---

During startup and light load operation on certain standby generator set applications, white smoke and wetness in the exhaust system may be experienced in cold ambient conditions of below 7° C (45° F). When a diesel engine is operated on light loads, the engine does not reach and maintain the correct operating temperature.

When the diesel engine runs below the designed operating temperature for extended periods, unburned fuel accumulates and that causes wetness in the exhaust system. The following recommendation will reduce the symptoms, but will not fully eliminate the symptoms.

The recommendation to achieve increased cylinder temperature of the engine is to apply a minimum load of 30 percent to reduce white smoke and accumulation of unburned fuel.

If the engine has not been run for several weeks, fuel may have drained. Air may have moved into the filter housing. Also, when fuel filters have been changed, some air will be left in the filter housing. Refer to Operation and Maintenance Manual, "Fuel System - Prime" to remove air from the fuel system.

Use the procedure that follows for cold weather starting.

---

#### NOTICE

Do not engage the starting motor when flywheel is turning. Do not start the engine under load.

If the engine fails to start within 30 seconds, release the starter switch or button and wait 30 seconds. The 30 second wait, allows the starting motor to cool before attempting to start the engine again.

---

1. If equipped, press the start button. If equipped, turn the keyswitch to the START position to engage the electric starting motor and crank the engine.
2. Repeat step 1 three times if the engine fails to start.
3. If the engine fails to start, investigate the problem. Use the Perkins electronic service tool. A system fault may be indicated after the engine is started. If a fault is indicated, the ECM has detected a problem with the system. Investigate the cause of the problem. Use the Perkins electronic service tool.

**Note:** Oil pressure should rise within 15 seconds after the engine starts. The electronic engine controls monitor the oil pressure. The electronic controls will stop the engine if the oil pressure is below normal.

4. Operate the engine at no load until all the coolant temperature starts to rise. Check the gauges during the warmup period.

**Note:** The cold start strategy will be activated when the coolant temperature is below 17 °C (63 °F). The cold start strategy will continue until the coolant temperature reaches 28 °C (82 °F), or until the engine has been running for 14 minutes. A timer will disable the cold start strategy after a maximum time of 14 minutes.

**Note:** The oil pressures and fuel pressures should be in the normal range on the instrument panel. Do not apply a load to the engine until the oil pressure gauge indicates at least normal pressure. Inspect the engine for leaks and/or unusual noises.

**Note:** After the ECM has completed the cold mode, cold mode cannot be enabled again until the ECM is switched OFF.

**Note:** Do not attempt to restart the engine until the engine has completely stopped.

i02428473

## Starting with Jump Start Cables

Do not use jump start cables in order to start the engine. Charge the batteries or replace the batteries. Refer to Operation and Maintenance Manual, "Battery - Replace".

i02428529

## After Starting Engine

For new installations and engines that are recently rebuilt, carefully monitor the engine in order to detect any unusual engine performance.

Check for leaks in the air and in the fluid systems.

## Engine Operation

i02578030

### Engine Operation

Correct operation and maintenance are key factors in obtaining the maximum life and economy of the engine. If the directions in the Operation and Maintenance Manual are followed, costs can be minimized and engine service life can be maximized.

Gauge readings should be observed and the data should be recorded frequently while the engine is operating. Comparing the data over time will help to determine normal readings for each gauge. Comparing data over time will also help detect abnormal operating developments. Significant changes in the readings should be investigated.

i02583385

### Fuel Conservation Practices

The efficiency of the engine can affect the fuel economy. Perkins design and technology in manufacturing provides maximum fuel efficiency in all applications. Follow the recommended procedures in order to attain optimum performance for the life of the engine.

- Avoid spilling fuel.

Fuel expands when the fuel is warmed up. The fuel may overflow from the fuel tank. Inspect fuel lines for leaks. Repair the fuel lines, as needed.

- Be aware of the properties of the different fuels. Use only the recommended fuels.
- Avoid unnecessary operation at no load.

Shut off the engine instead of operating the engine at no load for long periods of time.

- Observe the service indicator for the air cleaner frequently, if equipped. Keep the air cleaner elements clean.
- Maintain a good electrical system.

One bad battery cell will overwork the alternator. This will consume excess power and excess fuel.

- Ensure that the belts are properly adjusted. The belts should be in good condition.
- Ensure that all of the connections of the hoses are tight. The connections should not leak.

- Ensure that the driven equipment is in good working order.
- Cold engines consume excess fuel. Keep cooling system components clean and keep cooling system components in good repair. Never operate the engine without water temperature regulators. All of these items will help maintain operating temperatures.

# Engine Stopping

i02572824

## Manual Stop Procedure

### Stopping the Engine

---

#### NOTICE

Stopping the engine immediately after it has been working under load, can result in overheating and accelerated wear of the engine components.

Avoid accelerating the engine prior to shutting it down.

Avoiding hot engine shutdowns will maximize turbo-charger shaft and bearing life.

---

**Note:** Individual applications will have different control systems. Ensure that the shutoff procedures are understood. Use the following general guidelines in order to stop the engine.

1. Remove the load from the engine. Allow the engine to run under no load conditions for five minutes in order to cool the engine.
2. Stop the engine after the cool down period according to the shutoff system on the engine and turn the ignition keyswitch to the OFF position. If necessary, refer to the instructions that are provided by the OEM.

### Emergency Stopping

---

#### NOTICE

Emergency shutoff controls are for EMERGENCY use ONLY. DO NOT use emergency shutoff devices or controls for normal stopping procedure.

---

The OEM may have equipped the application with an emergency stop button. For more information about the emergency stop button, refer to the OEM information.

Ensure that any components for the external system that support the engine operation are secured after the engine is stopped.

i02583411

## After Stopping Engine

**Note:** Before you check the engine oil, do not operate the engine for at least 10 minutes in order to allow the engine oil to return to the oil pan.

- Check the crankcase oil level. Maintain the oil level between the “LOW” mark and the “HIGH” mark on the oil level gauge.

**Note:** Only use oil that is recommended in this Operation and Maintenance Manual, “Fluid Recommendations”. Failure to use the recommended oil may result in engine damage.

- If necessary, perform minor adjustments. Repair any leaks and tighten any loose bolts.
- Note the service hour meter reading. Perform the maintenance that is in the Operation and Maintenance Manual, “Maintenance Interval Schedule”.
- Fill the fuel tank in order to help prevent accumulation of moisture in the fuel. Do not overfill the fuel tank.
- Allow the engine to cool. Check the coolant level. Maintain the cooling system at 13 mm (0.5 inch) from the bottom of the pipe for filling.

**Note:** Only use coolant that is recommended in this Operation and Maintenance Manual, “Fluid Recommendations”. Failure to use the recommended oil may result in engine damage.

- If freezing temperatures are expected, check the coolant for proper antifreeze protection. The cooling system must be protected against freezing to the lowest expected outside temperature. Add the proper coolant/water mixture, if necessary.
- Perform all required periodic maintenance on all driven equipment. This maintenance is outlined in the instructions from the OEM.

# Cold Weather Operation

i02581613

## Cold Weather Operation

Perkins Diesel Engines can operate effectively in cold weather. During cold weather, the starting and the operation of the diesel engine is dependent on the following items:

- The type of fuel that is used
- The viscosity of the engine oil
- Optional Cold starting aid
- Battery condition

The operation and maintenance of an engine in freezing temperatures is complex. This is because of the following conditions:

- Weather conditions
- Engine applications

Recommendations from your Perkins distributor are based on past proven practices. The information that is contained in this section provides guidelines for cold weather operation.

### Hints for Cold Weather Operation

- If the engine will start, operate the engine until a minimum operating temperature of 81 °C (177.8 °F) is achieved. Achieving operating temperature will help prevent the intake valves and exhaust valves from sticking.
- The cooling system and the lubrication system for the engine do not lose heat immediately upon shutdown. This means that an engine can be shut down for a period of time and the engine can still have the ability to start readily.
- Install the correct specification of engine lubricant before the beginning of cold weather.
- Check all rubber parts (hoses, fan drive belts, etc) weekly.
- Check all electrical wiring and connections for any fraying or damaged insulation.
- Keep all batteries fully charged and warm.
- Check the air cleaners and the air intake daily.

### WARNING

**Personal injury or property damage can result from alcohol or starting fluids.**

**Alcohol or starting fluids are highly flammable and toxic and if improperly stored could result in injury or property damage.**

### WARNING

**Do not use aerosol types of starting aids such as ether. Such use could result in an explosion and personal injury.**

## Viscosity of the Engine Lubrication Oil

Correct engine oil viscosity is essential. Oil viscosity affects the amount of torque that is needed to crank the engine. Refer to Operation and Maintenance Manual, "Fluid Recommendations" for the recommended viscosity of oil.

## Recommendations for the Coolant

Provide cooling system protection for the lowest expected outside temperature. Refer to this Operation and Maintenance Manual, "Fluid Recommendations" for the recommended coolant mixture.

In cold weather, check the coolant often for the correct glycol concentration in order to ensure adequate freeze protection.

### Engine Block Heaters

Engine block heaters (if equipped) heat the engine jacket water that surrounds the combustion chambers. This provides the following functions:

- Startability is improved.

An electric block heater can be activated once the engine is stopped. An effective block heater is typically a 1250/1500 W unit. Consult your Perkins distributor for more information.

i02576035

## Fuel and the Effect from Cold Weather

**Note:** Only use grades of fuel that are recommended by Perkins. Refer to this Operation and Maintenance Manual, "Fluid Recommendations".

The following fuels can be used in this series of engine.

- Group 1
- Group 2
- Group 3
- Special Fuels

Perkins prefer only Group 1 and Group 2 fuels for use in this series of engines.

Group 1 fuels are the preferred Group of Fuels for general use by Perkins. Group 1 fuels maximize engine life and engine performance. Group 1 fuels are usually less available than Group 2 fuels. Frequently, Group 1 fuels are not available in colder climates during the winter.

**Note:** Group 2 fuels must have a maximum wear scar of 650 micrometers (HFRR to ISO 12156-1).

Group 2 fuels are considered acceptable for issues of warranty. This group of fuels may reduce the life of the engine, the engine's maximum power, and the engine's fuel efficiency.

When Group 2 diesel fuels are used the following components provide a means of minimizing problems in cold weather:

- Glow plugs (if equipped)
- Engine coolant heaters, which may be an OEM option
- Fuel heaters, which may be an OEM option
- Fuel line insulation, which may be an OEM option

There are three major differences between Group 1 fuels and Group 2 fuels. Group 1 fuels have the following different characteristics to Group 2 fuels.

- A lower cloud point
- A lower pour point
- A lower energy per unit volume of fuel

**Note:** Group 3 fuels reduce the life of the engine. The use of Group 3 fuels is not covered by the Perkins warranty.

Group 3 fuels include Low Temperature Fuels and Aviation Kerosene Fuels.

Special fuels include Biofuel.

The cloud point is a temperature that allows wax crystals to form in the fuel. These crystals can cause the fuel filters to plug.

The pour point is the temperature when diesel fuel will thicken. The diesel fuel becomes more resistant to flow through fuel lines, fuel filters, and fuel pumps.

Be aware of these facts when diesel fuel is purchased. Consider the average ambient air temperature for the engine's application. Engines that are fueled in one climate may not operate well if the engines are moved to another climate. Problems can result due to changes in temperature.

Before troubleshooting for low power or for poor performance in the winter, check the fuel for waxing.

Low temperature fuels may be available for engine operation at temperatures below 0 °C (32 °F). These fuels limit the formation of wax in the fuel at low temperatures.

For more information on cold weather operation, refer to the Operation and Maintenance Manual, "Cold Weather Operation and Fuel Related Components in Cold Weather".

i02583420

## Fuel Related Components in Cold Weather

### Fuel Tanks

Condensation can form in partially filled fuel tanks. Top off the fuel tanks after you operate the engine.

Fuel tanks should contain some provision for draining water and sediment from the bottom of the tanks. Some fuel tanks use supply pipes that allow water and sediment to settle below the end of the fuel supply pipe.

Some fuel tanks use supply lines that take fuel directly from the bottom of the tank. If the engine is equipped with this system, regular maintenance of the fuel system filter is important.

Drain the water and sediment from any fuel storage tank at the following intervals: weekly, oil changes and refueling of the fuel tank. This will help prevent water and/or sediment from being pumped from the fuel storage tank and into the engine fuel tank.

### Fuel Filters

A primary fuel filter is installed between the fuel tank and the engine fuel inlet. After you change the fuel filter, always prime the fuel system in order to remove air bubbles from the fuel system. Refer to the Operation and Maintenance Manual in the Maintenance Section for more information on priming the fuel system.



The micron rating and the location of a primary fuel filter is important in cold weather operation. The primary fuel filter and the fuel supply line are the most common components that are affected by cold fuel.

# Maintenance Section

## Refill Capacities

i02574012

### Refill Capacities

#### Lubrication System

The refill capacities for the engine crankcase reflect the approximate capacity of the crankcase or sump plus standard oil filters. Auxiliary oil filter systems will require additional oil. Refer to the OEM specifications for the capacity of the auxiliary oil filter. Refer to the Operation and Maintenance Manual, "Maintenance Section" for more information on Lubricant Specifications.

Table 3

| Engine Refill Capacities          |                      |                      |
|-----------------------------------|----------------------|----------------------|
| Compartment or System             | Minimum              | Maximum              |
| Crankcase Oil Sump <sup>(1)</sup> | 45 L<br>(10 Imp gal) | 53 L<br>(12 Imp gal) |

<sup>(1)</sup> These values are the approximate capacities for the crankcase oil sump (aluminum) which includes the standard factory installed oil filters. Engines with auxiliary oil filters will require additional oil. Refer to the OEM specifications for the capacity of the auxiliary oil filter.

#### Cooling System

Refer to the OEM specifications for the External System capacity. This capacity information will be needed in order to determine the amount of antifreeze/coolant that is required for the Total Cooling System.

Table 4

| Engine Refill Capacities               |                  |
|----------------------------------------|------------------|
| Compartment or System                  | Liters           |
| Engine Only                            | 22 L (5 Imp gal) |
| External System Per OEM <sup>(1)</sup> | 36 L (8 Imp gal) |

(continued)

(Table 4, contd)

<sup>(1)</sup> The External System includes a radiator or an expansion tank with the following components: heat exchanger and piping. Refer to the OEM specifications. Enter the value for the capacity of the External System in this row.

i02575700

## Fluid Recommendations

### General Lubricant Information

Because of government regulations regarding the certification of exhaust emissions from the engine, the lubricant recommendations must be followed.

### Engine Manufacturers Association (EMA) Oils

The "Engine Manufacturers Association Recommended Guideline on Diesel Engine Oil" is recognized by Perkins. For detailed information about this guideline, see the latest edition of EMA publication, "EMA DHD -1".

### API Oils

The Engine Oil Licensing and Certification System by the American Petroleum Institute (API) is recognized by Perkins. For detailed information about this system, see the latest edition of the "API publication No. 1509". Engine oils that bear the API symbol are authorized by API.

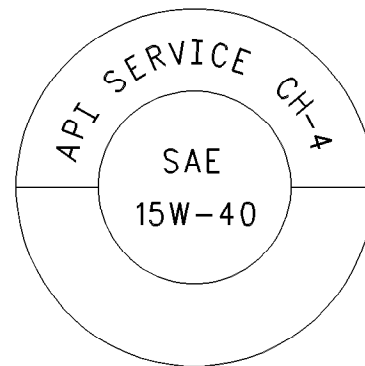

Illustration 21

g00546535

Typical API symbol

Diesel engine oils CC, CD, CD-2, and CE have not been API authorized classifications since January 1, 1996. Table 5 summarizes the status of the classifications.

Table 5

| API Classifications |                     |
|---------------------|---------------------|
| Current             | Obsolete            |
| CH-4, , CI-4        | CE, CC, CD          |
| -                   | CD-2 <sup>(1)</sup> |

<sup>(1)</sup> The oil CD-2 is for a two-cycle diesel engine. Perkins does not sell engines that utilize CD-2 oil.

## Terminology

Certain abbreviations follow the nomenclature of "SAE J754". Some classifications follow "SAE J183" abbreviations, and some classifications follow the "EMA Recommended Guideline on Diesel Engine Oil". In addition to Perkins definitions, there are other definitions that will be of assistance in purchasing lubricants. Recommended oil viscosities can be found in this publication, "Fluid Recommendations/ Engine Oil" topic (Maintenance Section).

## Engine Oil

### Commercial Oils

The performance of commercial diesel engine oils is based on American Petroleum Institute (API) classifications. These API classifications are developed in order to provide commercial lubricants for a broad range of diesel engines that operate at various conditions.

Only use commercial oils that meet the following classifications:

- API CH-4 CI-4

In order to make the correct choice of a commercial oil, refer to the following explanations:

**EMA DHD-1** – The Engine Manufacturers Association (EMA) has developed lubricant recommendations as an alternative to the API oil classification system. DHD-1 is a Recommended Guideline that defines a level of oil performance for these types of diesel engines: high speed, four stroke cycle, heavy-duty and light duty. DHD-1 oils may be used in Perkins engines when the following oils are recommended: API CH-4, API CG-4 and API CF-4. DHD-1 oils are intended to provide superior performance in comparison to API CG-4 and API CF-4.

DHD-1 oils will meet the needs of high performance Perkins diesel engines that are operating in many applications. The tests and the test limits that are used to define DHD-1 are similar to the new API CH-4 classification. Therefore, these oils will also meet the requirements for diesel engines that require low emissions. DHD-1 oils are designed to control the harmful effects of soot with improved wear resistance and improved resistance to plugging of the oil filter. These oils will also provide superior piston deposit control for engines with either two-piece steel pistons or aluminum pistons.

All DHD-1 oils must complete a full test program with the base stock and with the viscosity grade of the finished commercial oil. The use of "API Base Oil Interchange Guidelines" are not appropriate for DHD-1 oils. This feature reduces the variation in performance that can occur when base stocks are changed in commercial oil formulations.

DHD-1 oils are recommended for use in extended oil change interval programs that optimize the life of the oil. These oil change interval programs are based on oil analysis. DHD-1 oils are recommended for conditions that demand a premium oil. Your Perkins dealer or your Perkins distributor has the specific guidelines for optimizing oil change intervals.

**API CH-4** – API CH-4 oils were developed in order to meet the requirements of the new high performance diesel engines. Also, the oil was designed to meet the requirements of the low emissions diesel engines. API CH-4 oils are also acceptable for use in older diesel engines and in diesel engines that use high sulfur diesel fuel. API CH-4 oils may be used in Perkins engines that use API CG-4 and API CF-4 oils. API CH-4 oils will generally exceed the performance of API CG-4 oils in the following criteria: deposits on pistons, control of oil consumption, wear of piston rings, valve train wear, viscosity control and corrosion.

Three new engine tests were developed for the API CH-4 oil. The first test specifically evaluates deposits on pistons for engines with the two-piece steel piston. This test (piston deposit) also measures the control of oil consumption. A second test is conducted with moderate oil soot. The second test measures the following criteria: wear of piston rings, wear of cylinder liners and resistance to corrosion. A third new test measures the following characteristics with high levels of soot in the oil: wear of the valve train, resistance of the oil in plugging the oil filter and control of sludge.

In addition to the new tests, API CH-4 oils have tougher limits for viscosity control in applications that generate high soot. The oils also have improved oxidation resistance. API CH-4 oils must pass an additional test (piston deposit) for engines that use aluminum pistons (single piece). Oil performance is also established for engines that operate in areas with high sulfur diesel fuel.

All of these improvements allow the API CH-4 oil to achieve optimum oil change intervals. API CH-4 oils are recommended for use in extended oil change intervals. API CH-4 oils are recommended for conditions that demand a premium oil. Your Perkins dealer or your Perkins distributor has specific guidelines for optimizing oil change intervals.

Some commercial oils that meet the API classifications may require reduced oil change intervals. To determine the oil change interval, closely monitor the condition of the oil and perform a wear metal analysis.

**NOTICE**

Failure to follow these oil recommendations can cause shortened engine service life due to deposits and/or excessive wear.

**Total Base Number (TBN) and Fuel Sulfur Levels for Direct Injection (DI) Diesel Engines**

The Total Base Number (TBN) for an oil depends on the fuel sulfur level. For direct injection engines that use distillate fuel, the minimum TBN of the new oil must be 10 times the fuel sulfur level. The TBN is defined by "ASTM D2896". The minimum TBN of the oil is 5 regardless of fuel sulfur level. Illustration 22 demonstrates the TBN.

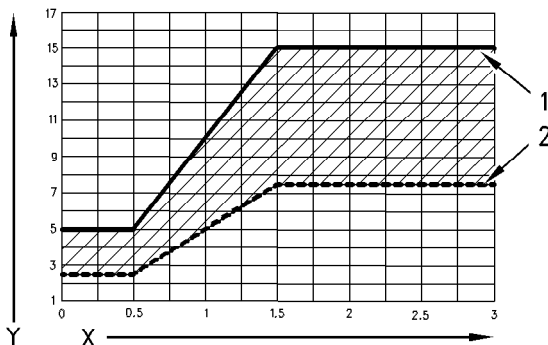

Illustration 22

g00799818

- (Y) TBN by "ASTM D2896"
- (X) Percentage of fuel sulfur by weight
- (1) TBN of new oil
- (2) Change the oil when the TBN deteriorates to 50 percent of the original TBN.

Use the following guidelines for fuel sulfur levels that exceed 1.5 percent:

- Choose an oil with the highest TBN that meets one of these classifications: EMA DHD-1 and API CH-4.

- Reduce the oil change interval. Base the oil change interval on the oil analysis. Ensure that the oil analysis includes the condition of the oil and a wear metal analysis.

Excessive piston deposits can be produced by an oil with a high TBN. These deposits can lead to a loss of control of the oil consumption and to the polishing of the cylinder bore.

**NOTICE**

Operating Direct Injection (DI) diesel engines with fuel sulphur levels over 0.5 percent will require shortened oil change intervals in order to help maintain adequate wear protection.

Table 6

| Percentage of Sulfur in the fuel | Oil change interval |
|----------------------------------|---------------------|
| Lower than 0.5                   | Normal              |
| 0.5 to 1.0                       | 0.75 of normal      |
| Greater than 1.0                 | 0.50 of normal      |

**Lubricant Viscosity Recommendations for Direct Injection (DI) Diesel Engines**

The correct SAE viscosity grade of oil is determined by the minimum ambient temperature during cold engine start-up, and the maximum ambient temperature during engine operation.

Refer to Table 7 (minimum temperature) in order to determine the required oil viscosity for starting a cold engine.

Refer to Table 7 (maximum temperature) in order to select the oil viscosity for engine operation at the highest ambient temperature that is anticipated.

Generally, use the highest oil viscosity that is available to meet the requirement for the temperature at start-up.

Table 7

| Engine Oil Viscosity                     |                     |                |
|------------------------------------------|---------------------|----------------|
| EMA LRG-1<br>API CH-4<br>Viscosity Grade | Ambient Temperature |                |
|                                          | Minimum             | Maximum        |
| SAE 0W20                                 | -40 °C (-40 °F)     | 10 °C (50 °F)  |
| SAE 0W30                                 | -40 °C (-40 °F)     | 30 °C (86 °F)  |
| SAE 0W40                                 | -40 °C (-40 °F)     | 40 °C (104 °F) |
| SAE 5W30                                 | -30 °C (-22 °F)     | 30 °C (86 °F)  |
| SAE 5W40                                 | -30 °C (-22 °F)     | 40 °C (104 °F) |
| SAE 10W30                                | -20 °C (-4 °F)      | 40 °C (104 °F) |
| SAE 15W40                                | -10 °C (14 °F)      | 50 °C (122 °F) |

## Synthetic Base Stock Oils

Synthetic base oils are acceptable for use in these engines if these oils meet the performance requirements that are specified for the engine.

Synthetic base oils generally perform better than conventional oils in the following two areas:

- Synthetic base oils have improved flow at low temperatures especially in arctic conditions.
- Synthetic base oils have improved oxidation stability especially at high operating temperatures.

Some synthetic base oils have performance characteristics that enhance the service life of the oil. Perkins does not recommend the automatic extending of the oil change intervals for any type of oil.

## Re-refined Base Stock Oils

Re-refined base stock oils are acceptable for use in Perkins engines if these oils meet the performance requirements that are specified by Perkins. Re-refined base stock oils can be used exclusively in finished oil or in a combination with new base stock oils. The US military specifications and the specifications of other heavy equipment manufacturers also allow the use of re-refined base stock oils that meet the same criteria.

The process that is used to make re-refined base stock oil should adequately remove all wear metals that are in the used oil and all the additives that are in the used oil. The process that is used to make re-refined base stock oil generally involves the process of vacuum distillation and hydrotreating the used oil. Filtering is adequate for the production of high quality, re-refined base stock oil.

## Lubricants for Cold Weather

When an engine is started and an engine is operated in ambient temperatures below  $-20^{\circ}\text{C}$  ( $-4^{\circ}\text{F}$ ), use multigrade oils that are capable of flowing in low temperatures.

These oils have lubricant viscosity grades of SAE 0W or SAE 5W.

When an engine is started and operated in ambient temperatures below  $-30^{\circ}\text{C}$  ( $-22^{\circ}\text{F}$ ), use a synthetic base stock multigrade oil with an 0W viscosity grade or with a 5W viscosity grade. Use an oil with a pour point that is lower than  $-50^{\circ}\text{C}$  ( $-58^{\circ}\text{F}$ ).

The number of acceptable lubricants is limited in cold weather conditions. Perkins recommends the following lubricants for use in cold weather conditions:

**First Choice** – Use oil with an EMA DHD-1 Recommended Guideline. Use a CH-4 oil that has an API license. The oil should be either SAE 0W20, SAE

0W30, SAE 0W40, SAE 5W30, or SAE 5W40 lubricant viscosity grade.

**Second Choice** – Use an oil that has a CH-4 additive package. Although the oil has not been tested for the requirements of the API license, the oil must be either SAE 0W20, SAE 0W30, SAE 0W40, SAE 5W30, or SAE 5W40.

---

### NOTICE

Shortened engine service life could result if second choice oils are used.

---

## Aftermarket Oil Additives

Perkins does not recommend the use of aftermarket additives in oil. It is not necessary to use aftermarket additives in order to achieve the engine's maximum service life or rated performance. Fully formulated, finished oils consist of base oils and of commercial additive packages. These additive packages are blended into the base oils at precise percentages in order to help provide finished oils with performance characteristics that meet industry standards.

There are no industry standard tests that evaluate the performance or the compatibility of aftermarket additives in finished oil. Aftermarket additives may not be compatible with the finished oil's additive package, which could lower the performance of the finished oil. The aftermarket additive could fail to mix with the finished oil. This could produce sludge in the crankcase. Perkins discourages the use of aftermarket additives in finished oils.

To achieve the best performance from a Perkins engine, conform to the following guidelines:

- Select the correct oil, or a commercial oil that meets the "EMA Recommended Guideline on Diesel Engine Oil" or the recommended API classification.
- See the appropriate "Lubricant Viscosities" table in order to find the correct oil viscosity grade for your engine.
- At the specified interval, service the engine. Use new oil and install a new oil filter.
- Perform maintenance at the intervals that are specified in the Operation and Maintenance Manual, "Maintenance Interval Schedule".

## Oil analysis

Some engines may be equipped with an oil sampling valve. If oil analysis is required the oil sampling valve is used to obtain samples of the engine oil. The oil analysis will complement the preventive maintenance program.

The oil analysis is a diagnostic tool that is used to determine oil performance and component wear rates. Contamination can be identified and measured through the use of the oil analysis. The oil analysis includes the following tests:

- The Wear Rate Analysis monitors the wear of the engine's metals. The amount of wear metal and type of wear metal that is in the oil is analyzed. The increase in the rate of engine wear metal in the oil is as important as the quantity of engine wear metal in the oil.
- Tests are conducted in order to detect contamination of the oil by water, glycol or fuel.
- The Oil Condition Analysis determines the loss of the oil's lubricating properties. An infrared analysis is used to compare the properties of new oil to the properties of the used oil sample. This analysis allows technicians to determine the amount of deterioration of the oil during use. This analysis also allows technicians to verify the performance of the oil according to the specification during the entire oil change interval.

## Fuel Specifications

### Fuel Recommendations

To get the correct power and performance from the engine, use a fuel of the correct quality. The recommended fuel specification for Perkins engines is shown below:

- Cetane number \_\_\_\_\_ 45 minimum
- Viscosity \_\_\_\_\_ 2,0 to 4.5 cSt at 40 °C (104 °F)
- Density \_\_\_\_\_ 0.835 to 0.855 Kg/liter
- Sulfur \_\_\_\_\_ 0.2% of mass, maximum
- Distillation \_\_\_\_\_ 85% at 350 °C (662 °F)
- Lubricity \_\_\_\_\_ 460 micrometers maximum wear scar on "ISO 12156 - 1"

#### Cetane number

This indicates the properties of ignition of the fuel. Fuel with a low cetane number can be the root cause of problems during cold start. This will affect combustion.

#### Viscosity

This is the resistance to flow of a fluid. If this resistance is outside the limits, the engine and the engine starting performance in particular can be affected.

#### Sulfur

High sulfur content of the fuel is not normally found in Europe, North America or Australasia. This can cause engine wear. When only high sulfur fuels are available, it will be necessary that high alkaline lubricating oil is used in the engine or that the lubricating oil change interval is reduced.

#### Distillation

This is an indication of the mixture of different hydrocarbons in the fuel. A high ratio of light weight hydrocarbons can affect the characteristics of combustion.

#### Lubricity

This is the capability of the fuel to prevent pump wear.

Diesel engines have the ability to burn a wide variety of fuels. These fuels are divided into four general groups:

- Group 1 (preferred fuels)
- Group 2 (permissible fuels)
- Group 3 (aviation kerosene fuels)
- Other fuels

#### Group 1 (preferred fuels): Specification

"DERV to EN590"

**Note:** Only use Arctic fuels when the temperature is below 0 °C (32 °F). Do not use Arctic fuels when the ambient temperature is above 0 °C (32 °F). To ensure that the time period between cranking the engine and first fire is kept to a minimum, only use fuel of the correct viscosity and at the correct temperature.

Gas oil to "BS2869 Class A2"

"ASTM D975 - 91 Class 2D" This can only be used if the fuel has the correct specification of lubricity.

"JIS K2204 (1992) Grades 1,2,3 and Special Grade 3" This can only be used if the fuel has the correct specification of lubricity.

**Note:** If low sulfur or low sulfur aromatic fuels are used, then fuel additives can be used to increase lubricity.

#### Group 2 (permissible fuels): Specification

These fuel specifications are considered acceptable for issues of warranty. However, these fuels may reduce the life of the engine, the engine's maximum power and the engine's fuel efficiency.

"ASTM D975 - 91 Class 1D"

"JP7, Mil T38219"

"NATO F63"

**NOTICE**

These fuels should have a wear scar value of 650 micrometers maximum  
\*HFRR to ISO 12156 - 1.

**Group 3 (aviation kerosene fuels): Specification**

These fuels need additives to achieve lubricity of 650 micrometers wear scar and the reliability of the fuel pump and fuel injectors will be reduced. The fuel injection pump is not covered by a warranty, even when the additives are included.

“JP5 MIL T5624 (Avcat FSII, NATO F44)”

“JP8 T83133 (Avtur FSII, NATO F34)”

“Jet A”

“Jet A1, NATO F35, XF63”

Low temperature fuels

Special fuels for use in cold weather may be available for engine operation at temperatures below 0 °C (32 °F). These fuels limit the formation of wax in the fuel oil at low temperatures. If wax forms in the fuel oil, this could stop the flow of fuel oil through the filter.

**Note:** These fuels that lack lubricity may cause the following problems:

- Low engine power
- Difficult starting in hot conditions or in cold conditions
- White smoke
- Deterioration of emissions and misfire at certain operating conditions

**Biofuel: Specification**

Biofuel: A 5% mix of RME to EN14214 in conventional fuel is permitted.

**NOTICE**

Water emulsion fuels: These fuels are not permitted

**Refer to the following fuel specifications for North America.**

The preferred fuels provide maximum engine service life and performance. The preferred fuels are distillate fuels. These fuels are commonly called diesel fuel or gas oil.

The permissible fuels are crude oils or blended fuels. Use of these fuels can result in higher maintenance costs and in reduced engine service life.

Diesel fuels that meet the specifications in Table 8 will help to provide maximum engine service life and performance. In North America, diesel fuel that is identified as No. 2-D in “ASTM D975” generally meets the specifications. Table 8 is for diesel fuels that are distilled from crude oil. Diesel fuels from other sources could exhibit detrimental properties that are not defined or controlled by this specification.

Table 8

| Perkins Specifications for Distillate Diesel Fuel |                                                                          |                    |
|---------------------------------------------------|--------------------------------------------------------------------------|--------------------|
| Specifications                                    | Requirements                                                             | ASTM Test          |
| Aromatics                                         | 35% maximum                                                              | “D1319”            |
| Ash                                               | 0.02% maximum (weight)                                                   | “D482”             |
| Carbon Residue on 10% Bottoms                     | 0.35% maximum (weight)                                                   | “D524”             |
| Cetane Number                                     | 40 minimum (DI engines)                                                  | “D613”             |
| Cloud Point                                       | The cloud point must not exceed the lowest expected ambient temperature. | -                  |
| Copper Strip Corrosion                            | No. 3 maximum                                                            | “D130”             |
| Distillation                                      | 10% at 282 °C (540 °F) maximum                                           | “D86”              |
|                                                   | 90% at 360 °C (680 °F) maximum                                           |                    |
| Flash Point                                       | legal limit                                                              | “D93”              |
| API Gravity                                       | 30 minimum                                                               | “D287”             |
|                                                   | 45 maximum                                                               |                    |
| Pour Point                                        | 6 °C (10 °F) minimum below ambient temperature                           | “D97”              |
| Sulfur <sup>(1)</sup>                             | 0.2% maximum                                                             | “D3605” or “D1552” |
| Kinematic Viscosity <sup>(2)</sup>                | 2.0 cSt minimum and 4.5 cSt maximum at 40 °C (104 °F)                    | “D445”             |
| Water and Sediment                                | 0.1% maximum                                                             | “D1796”            |
| Water                                             | 0.1% maximum                                                             | “D1744”            |
| Sediment                                          | 0.05% maximum (weight)                                                   | “D473”             |

(continued)

Maintenance Section  
Fluid Recommendations

(Table 8, contd)

|                               |                                               |         |
|-------------------------------|-----------------------------------------------|---------|
| Gum and Resins <sup>(3)</sup> | 10 mg per 100 mL maximum                      | "D381"  |
| Lubricity <sup>(4)</sup>      | 0.38 mm (0.015 inch) maximum at 25 °C (77 °F) | "D6079" |

- (1) Perkins fuel systems and engine components can operate on high sulfur fuels. Fuel sulfur levels affect exhaust emissions. High sulfur fuels also increase the potential for corrosion of internal components. Fuel sulfur levels above 0.5 percent may significantly shorten the oil change interval. For additional information, see this publication, "Fluid Recommendations/Engine Oil" topic (Maintenance Section).
- (2) The values of the fuel viscosity are the values as the fuel is delivered to the fuel injection pumps. If a fuel with a low viscosity is used, cooling of the fuel may be required to maintain a 1.4 cSt viscosity at the fuel injection pump. Fuels with a high viscosity might require fuel heaters in order to bring down the viscosity to a 20 cSt viscosity.
- (3) Follow the test conditions and procedures for gasoline (motor).
- (4) The lubricity of a fuel is a concern with low sulfur fuel. To determine the lubricity of the fuel, use either the "ASTM D6078 Scuffing Load Wear Test (SBOCLE)" or the "ASTM D6079 High Frequency Reciprocating Rig (HFRR)" test. If the lubricity of a fuel does not meet the minimum requirements, consult your fuel supplier. Do not treat the fuel without consulting the fuel supplier. Some additives are not compatible. These additives can cause problems in the fuel system.

---

**NOTICE**

Operating with fuels that do not meet the Perkins recommendations can cause the following effects: Starting difficulty, poor combustion, deposits in the fuel injectors, reduced service life of the fuel system, deposits in the combustion chamber and reduced service life of the engine.

---



---

**NOTICE**

Heavy Fuel Oil (HFO), Residual fuel, or Blended fuel must NOT be used in Perkins diesel engines. Severe component wear and component failures will result if HFO type fuels are used in engines that are configured to use distillate fuel.

---

In extreme cold ambient conditions, you may use the distillate fuels that are specified in Table 9 . However, the fuel that is selected must meet the requirements that are specified in Table 8 . These fuels are intended to be used in operating temperatures that are down to -54 °C (-65 °F).

Table 9

| Distillate Fuels <sup>(1)</sup> |         |
|---------------------------------|---------|
| Specification                   | Grade   |
| "MIL-T-5624R"                   | JP-5    |
| "ASTM D1655"                    | Jet-A-1 |
| "MIL-T-83133D"                  | JP-8    |

(continued)

(Table 9, contd)

- (1) The fuels that are listed in this Table may not meet the requirements that are specified in the "Perkins Specifications for Distillate Diesel Fuel" Table. Consult the supplier for the recommended additives in order to maintain the correct fuel lubricity.

These fuels are lighter than the No. 2 grades of fuel. The cetane number of the fuels in Table 9 must be at least 40. If the viscosity is below 1.4 cSt at 38 °C (100 °F), use the fuel only in temperatures below 0 °C (32 °F). Do not use any fuels with a viscosity of less than 1.2 cSt at 38 °C (100 °F). Fuel cooling may be required in order to maintain the minimum viscosity of 1.4 cSt at the fuel injection pump.

There are many other diesel fuel specifications that are published by governments and by technological societies. Usually, those specifications do not review all the requirements that are addressed in this specification. To ensure optimum engine performance, a complete fuel analysis should be obtained before engine operation. The fuel analysis should include all of the properties that are listed in Table 8 .

## Cooling System Specifications

### General Coolant Information

---

**NOTICE**

Never add coolant to an overheated engine. Engine damage could result. Allow the engine to cool first.

---



---

**NOTICE**

If the engine is to be stored in, or shipped to an area with below freezing temperatures, the cooling system must be either protected to the lowest outside temperature or drained completely to prevent damage.

---



---

**NOTICE**

Frequently check the specific gravity of the coolant for proper freeze protection or for anti-boil protection.

---

Clean the cooling system for the following reasons:

- Contamination of the cooling system
  - Overheating of the engine
  - Foaming of the coolant
- 

---

**NOTICE**

Never operate an engine without water temperature regulators in the cooling system. Water temperature regulators help to maintain the engine coolant at the proper operating temperature. Cooling system problems can develop without water temperature regulators.

---



Many engine failures are related to the cooling system. The following problems are related to cooling system failures: Overheating, leakage of the water pump and plugged radiators or heat exchangers.

These failures can be avoided with correct cooling system maintenance. Cooling system maintenance is as important as maintenance of the fuel system and the lubrication system. Quality of the coolant is as important as the quality of the fuel and the lubricating oil.

Coolant is normally composed of three elements: Water, additives and glycol.

## Water

Water is used in the cooling system in order to transfer heat.

**Distilled water or deionized water is recommended for use in engine cooling systems.**

DO NOT use the following types of water in cooling systems: Hard water, softened water that has been conditioned with salt and sea water.

If distilled water or deionized water is not available, use water with the properties that are listed in Table 10.

Table 10

| Acceptable Water           |                  |
|----------------------------|------------------|
| Property                   | Maximum Limit    |
| Chloride (Cl)              | 40 mg/L          |
| Sulfate (SO <sub>4</sub> ) | 100 mg/L         |
| Total Hardness             | 170 mg/L         |
| Total Solids               | 340 mg/L         |
| Acidity                    | pH of 5.5 to 9.0 |

For a water analysis, consult one of the following sources:

- Local water utility company
- Agricultural agent
- Independent laboratory

## Additives

Additives help to protect the metal surfaces of the cooling system. A lack of coolant additives or insufficient amounts of additives enable the following conditions to occur:

- Corrosion
- Formation of mineral deposits
- Rust

- Scale
- Foaming of the coolant

Many additives are depleted during engine operation. These additives must be replaced periodically.

Additives must be added at the correct concentration. Overconcentration of additives can cause the inhibitors to drop out-of-solution. The deposits can enable the following problems to occur:

- Formation of gel compounds
- Reduction of heat transfer
- Leakage of the water pump seal
- Plugging of radiators, coolers, and small passages

## Glycol

Glycol in the coolant helps to provide protection against the following conditions:

- Boiling
- Freezing
- Cavitation of the water pump

For optimum performance, Perkins recommends a 1:1 mixture of a water/glycol solution.

**Note:** Use a mixture that will provide protection against the lowest ambient temperature.

**Note:** 100 percent pure glycol will freeze at a temperature of  $-23\text{ }^{\circ}\text{C}$  ( $-9\text{ }^{\circ}\text{F}$ ).

Most conventional antifreezes use ethylene glycol. Propylene glycol may also be used. In a 1:1 mixture with water, ethylene and propylene glycol provide similar protection against freezing and boiling. See Tables 11 and 12.

Table 11

| Ethylene Glycol |                                                                 |                                                                 |
|-----------------|-----------------------------------------------------------------|-----------------------------------------------------------------|
| Concentration   | Freeze Protection                                               | Boil Protection                                                 |
| 50 Percent      | $-36\text{ }^{\circ}\text{C}$ ( $-33\text{ }^{\circ}\text{F}$ ) | $106\text{ }^{\circ}\text{C}$ ( $223\text{ }^{\circ}\text{F}$ ) |
| 60 Percent      | $-51\text{ }^{\circ}\text{C}$ ( $-60\text{ }^{\circ}\text{F}$ ) | $111\text{ }^{\circ}\text{C}$ ( $232\text{ }^{\circ}\text{F}$ ) |

### NOTICE

Do not use propylene glycol in concentrations that exceed 50 percent glycol because of propylene glycol's reduced heat transfer capability. Use ethylene glycol in conditions that require additional protection against boiling or freezing.

Table 12

| Propylene Glycol |                   |                      |
|------------------|-------------------|----------------------|
| Concentration    | Freeze Protection | Anti-Boil Protection |
| 50 Percent       | -29 °C (-20 °F)   | 106 °C (223 °F)      |

To check the concentration of glycol in the coolant, measure the specific gravity of the coolant.

## Coolant Recommendations

The following two coolants are used in Perkins diesel engines:

**Preferred** – Perkins Extended Life Coolant (ELC)

**Acceptable** – A commercial heavy-duty antifreeze that meets “ASTM D4985” specifications

### NOTICE

Do not use a commercial coolant/antifreeze that only meets the ASTM D3306 specification. This type of coolant/antifreeze is made for light automotive applications.

Perkins recommends a 1:1 mixture of water and glycol. This mixture of water and glycol will provide optimum heavy-duty performance as a antifreeze. This ratio may be increased to 1:2 water to glycol if extra freezing protection is required.

**Note:** A commercial heavy-duty antifreeze that meets “ASTM D4985” specifications MAY require a treatment with an SCA at the initial fill. Read the label or the instructions that are provided by the OEM of the product.

In stationary engine applications and marine engine applications that do not require anti-boil protection or freeze protection, a mixture of SCA and water is acceptable. Perkins recommends a six percent to eight percent concentration of SCA in those cooling systems. Distilled water or deionized water is preferred. Water which has the recommended properties may be used.

Engines that are operating in an ambient temperature above 43 °C (109.4 °F) must use SCA and water. Engines that operate in an ambient temperature above 43 °C (109.4 °F) and below 0 °C (32 °F) due to seasonal variations consult your Perkins dealer or your Perkins distributor for the correct level of protection.

Table 13

| Coolant Service Life                                      |                                    |
|-----------------------------------------------------------|------------------------------------|
| Coolant Type                                              | Service Life                       |
| Perkins ELC                                               | 6,000 Service Hours or Three Years |
| Commercial Heavy-Duty Anti-freeze that meets “ASTM D4985” | 3000 Service Hours or Two Years    |
| Perkins POWERPART SCA                                     | 3000 Service Hours or Two Years    |
| Commercial SCA and Water                                  | 3000 Service Hours or Two Years    |

## Extended Life Coolant (ELC)

Perkins provides Extended Life Coolant (ELC) for use in the following applications:

- Heavy-duty spark ignited gas engines
- Heavy-duty diesel engines
- Automotive applications

The anti-corrosion package for ELC is different from the anti-corrosion package for other coolants. ELC is an ethylene glycol base coolant. However, ELC contains organic corrosion inhibitors and antifoam agents with low amounts of nitrite. Perkins ELC has been formulated with the correct amount of these additives in order to provide superior corrosion protection for all metals in engine cooling systems.

ELC is available in a 1:1 premixed cooling solution with distilled water. The Premixed ELC provides freeze protection to -36 °C (-33 °F). The Premixed ELC is recommended for the initial fill of the cooling system. The Premixed ELC is also recommended for topping off the cooling system.

ELC Concentrate is also available. ELC Concentrate can be used to lower the freezing point to -51 °C (-60 °F) for arctic conditions.

Containers of several sizes are available. Consult your Perkins dealer or your Perkins distributor for the part numbers.

## ELC Cooling System Maintenance

### Correct additions to the Extended Life Coolant

---

#### NOTICE

Use only Perkins products for pre-mixed or concentrated coolants.

Mixing Extended Life Coolant with other products reduces the Extended Life Coolant service life. Failure to follow the recommendations can reduce cooling system components life unless appropriate corrective action is performed.

In order to maintain the correct balance between the antifreeze and the additives, you must maintain the recommended concentration of Extended Life Coolant (ELC). Lowering the proportion of antifreeze lowers the proportion of additive. This will lower the ability of the coolant to protect the system from pitting, from cavitation, from erosion, and from deposits.

---

#### NOTICE

Do not use a conventional coolant to top-off a cooling system that is filled with Extended Life Coolant (ELC).

Do not use standard supplemental coolant additive (SCA).

When using Perkins ELC, do not use standard SCA's or SCA filters.

### ELC Cooling System Cleaning

**Note:** If the cooling system is already using ELC, cleaning agents are not required to be used at the specified coolant change interval. Cleaning agents are only required if the system has been contaminated by the addition of some other type of coolant or by cooling system damage.

Clean water is the only cleaning agent that is required when ELC is drained from the cooling system.

After the cooling system is drained and after the cooling system is refilled, operate the engine while the cooling system filler cap is removed. Operate the engine until the coolant level reaches the normal operating temperature and until the coolant level stabilizes. As needed, add the coolant mixture in order to fill the system to the specified level.

### Changing to Perkins ELC

To change from heavy-duty antifreeze to the Perkins ELC, perform the following steps:

---

#### NOTICE

Care must be taken to ensure that all fluids are contained during performance of inspection, maintenance, testing, adjusting and the repair of the product. Be prepared to collect the fluid with suitable containers before opening any compartment or disassembling any component containing fluids.

Dispose of all fluids according to local regulations and mandates.

- 
1. Drain the coolant into a suitable container.
  2. Dispose of the coolant according to local regulations.
  3. Flush the system with clean water in order to remove any debris.
  4. Use Perkins cleaner to clean the system. Follow the instruction on the label.
  5. Drain the cleaner into a suitable container. Flush the cooling system with clean water.
  6. Fill the cooling system with clean water and operate the engine until the engine is warmed to 49° to 66°C (120° to 150°F).

---

#### NOTICE

Incorrect or incomplete flushing of the cooling system can result in damage to copper and other metal components.

To avoid damage to the cooling system, make sure to completely flush the cooling system with clear water. Continue to flush the system until all the signs of the cleaning agent are gone.

- 
7. Drain the cooling system into a suitable container and flush the cooling system with clean water.

**Note:** The cooling system cleaner must be thoroughly flushed from the cooling system. Cooling system cleaner that is left in the system will contaminate the coolant. The cleaner may also corrode the cooling system.

8. Repeat Steps 6 and 7 until the system is completely clean.
9. Fill the cooling system with the Perkins Premixed ELC.

## ELC Cooling System Contamination

### NOTICE

Mixing ELC with other products reduces the effectiveness of the ELC and shortens the ELC service life. Use only Perkins Products for premixed or concentrate coolants. Failure to follow these recommendations can result in shortened cooling system component life.

ELC cooling systems can withstand contamination to a maximum of ten percent of conventional heavy-duty antifreeze or SCA. If the contamination exceeds ten percent of the total system capacity, perform ONE of the following procedures:

- Drain the cooling system into a suitable container. Dispose of the coolant according to local regulations. Flush the system with clean water. Fill the system with the Perkins ELC.
- Drain a portion of the cooling system into a suitable container according to local regulations. Then, fill the cooling system with premixed ELC. This should lower the contamination to less than 10 percent.
- Maintain the system as a conventional Heavy-Duty Coolant. Treat the system with an SCA. Change the coolant at the interval that is recommended for the conventional Heavy-Duty Coolant.

## Commercial Heavy-Duty Antifreeze and SCA

### NOTICE

Commercial Heavy-Duty Coolant which contains Amine as part of the corrosion protection system must not be used.

### NOTICE

Never operate an engine without water temperature regulators in the cooling system. Water temperature regulators help to maintain the engine coolant at the correct operating temperature. Cooling system problems can develop without water temperature regulators.

Check the antifreeze (glycol concentration) in order to ensure adequate protection against boiling or freezing. Perkins recommends the use of a refractometer for checking the glycol concentration.

Perkins engine cooling systems should be tested at 500 hour intervals for the concentration of Supplemental Coolant Additive (SCA).

Additions of SCA are based on the results of the test. An SCA that is liquid may be needed at 500 hour intervals.

Refer to Table 14 for part numbers and for quantities of SCA.

Table 14

| Perkins Liquid SCA |          |
|--------------------|----------|
| Part Number        | Quantity |
| 21825755           | .        |

## Adding the SCA to Heavy-Duty Coolant at the Initial Fill

Commercial heavy-duty antifreeze that meets "ASTM D4985" specifications MAY require an addition of SCA at the initial fill. Read the label or the instructions that are provided by the OEM of the product.

Use the equation that is in Table 15 to determine the amount of Perkins SCA that is required when the cooling system is initially filled.

Table 15

| Equation For Adding The SCA To The Heavy-Duty Coolant At The Initial Fill |
|---------------------------------------------------------------------------|
| $V \times 0.045 = X$                                                      |
| V is the total volume of the cooling system.                              |
| X is the amount of SCA that is required.                                  |

Table 16 is an example for using the equation that is in Table 15 .

Table 16

| Example Of The Equation For Adding The SCA To The Heavy-Duty Coolant At The Initial Fill |                       |                                    |
|------------------------------------------------------------------------------------------|-----------------------|------------------------------------|
| Total Volume of the Cooling System (V)                                                   | Multiplication Factor | Amount of SCA that is Required (X) |
| 15 L (4 US gal)                                                                          | × 0.045               | 0.7 L (24 oz)                      |

## Adding The SCA to The Heavy-Duty Coolant For Maintenance

Heavy-duty antifreeze of all types REQUIRE periodic additions of an SCA.

Test the antifreeze periodically for the concentration of SCA. For the interval, refer to the Operation and Maintenance Manual, "Maintenance Interval Schedule" (Maintenance Section). Test the concentration of SCA.

Additions of SCA are based on the results of the test. The size of the cooling system determines the amount of SCA that is needed.

Use the equation that is in Table 17 to determine the amount of Perkins SCA that is required, if necessary:

Table 17

| <b>Equation For Adding The SCA To The Heavy-Duty Coolant For Maintenance</b> |
|------------------------------------------------------------------------------|
| <b><math>V \times 0.014 = X</math></b>                                       |
| V is the total volume of the cooling system.                                 |
| X is the amount of SCA that is required.                                     |

Table 18 is an example for using the equation that is in Table 17 .

Table 18

| <b>Example Of The Equation For Adding The SCA To The Heavy-Duty Coolant For Maintenance</b> |                              |                                           |
|---------------------------------------------------------------------------------------------|------------------------------|-------------------------------------------|
| <b>Total Volume of the Cooling System (V)</b>                                               | <b>Multiplication Factor</b> | <b>Amount of SCA that is Required (X)</b> |
| 15 L (4 US gal)                                                                             | × 0.014                      | 0.2 L (7 oz)                              |

## **Cleaning the System of Heavy-Duty Antifreeze**

Perkins cooling system cleaners are designed to clean the cooling system of harmful scale and corrosion. Perkins cooling system cleaners dissolve mineral scale, corrosion products, light oil contamination and sludge.

- Clean the cooling system after used coolant is drained or before the cooling system is filled with new coolant.
- Clean the cooling system whenever the coolant is contaminated or whenever the coolant is foaming.

i08358311

## Maintenance Interval Schedule

### When Required

|                                          |    |
|------------------------------------------|----|
| “ Battery - Replace”                     | 55 |
| “ Battery or Battery Cable - Disconnect” | 56 |
| “ Engine - Clean”                        | 62 |
| “ Engine Oil Sample - Obtain”            | 65 |
| “ Fuel System - Prime”                   | 69 |
| “ Severe Service Application - Check”    | 74 |

### Daily

|                                                       |    |
|-------------------------------------------------------|----|
| “ Cooling System Coolant Level - Check”               | 59 |
| “ Driven Equipment - Check”                           | 61 |
| “ Engine Air Cleaner Service Indicator - Inspect”     | 63 |
| “ Engine Oil Level - Check”                           | 65 |
| “ Fuel System Primary Filter/Water Separator - Drain” | 70 |
| “ Walk-Around Inspection”                             | 76 |

### Every 6000 Service Hours or 3 Years

|                                          |    |
|------------------------------------------|----|
| “ Cooling System Coolant (ELC) - Change” | 58 |
|------------------------------------------|----|

### Every 250 Service Hours or 1 Year

|                                         |    |
|-----------------------------------------|----|
| “ Battery Electrolyte Level - Check”    | 56 |
| “ Fuel Tank Water and Sediment - Drain” | 72 |

### Initial 500 Service Hours

|                                       |    |
|---------------------------------------|----|
| “ Engine Valve Lash - Inspect/Adjust” | 69 |
|---------------------------------------|----|

### Every 500 Service Hours

|                                   |    |
|-----------------------------------|----|
| “ Belts - Inspect/Adjust/Replace” | 57 |
|-----------------------------------|----|

### Every 500 Service Hours or 1 Year

|                                                                  |    |
|------------------------------------------------------------------|----|
| “ Aftercooler Core - Clean/Test”                                 | 55 |
| “ Engine Air Cleaner Element (Single Element) - Inspect/Replace” | 62 |
| “ Engine Crankcase Breather - Replace”                           | 64 |

|                                                                   |    |
|-------------------------------------------------------------------|----|
| “ Engine Mounts - Inspect”                                        | 65 |
| “ Engine Oil and Filter - Change”                                 | 66 |
| “ Fuel System Primary Filter (Water Separator) Element - Replace” | 70 |
| “ Fuel System Secondary Filter - Replace”                         | 71 |
| “ Hoses and Clamps - Inspect/Replace”                             | 72 |
| “ Radiator - Clean”                                               | 73 |

### Every 1000 Service Hours

|                                       |    |
|---------------------------------------|----|
| “ Engine Valve Lash - Inspect/Adjust” | 69 |
|---------------------------------------|----|

### Every 1000 Service Hours or 1 Year

|                                              |    |
|----------------------------------------------|----|
| “ Electronic Unit Injector - Inspect/Adjust” | 61 |
|----------------------------------------------|----|

### Every 2000 Service Hours

|                         |    |
|-------------------------|----|
| “ Alternator - Inspect” | 55 |
| “ Water Pump - Inspect” | 76 |

### Every 3000 Service Hours or 2 Years

|                                                         |    |
|---------------------------------------------------------|----|
| “ Cooling System Water Temperature Regulator - Replace” | 60 |
| “ Crankshaft Vibration Damper - Inspect”                | 60 |
| “ Engine Protective Devices - Check”                    | 68 |
| “ Engine Speed/Timing Sensors - Check/Clean/Calibrate”  | 68 |
| “ Turbocharger - Inspect”                               | 75 |

### Every 5000 Service Hours

|                             |    |
|-----------------------------|----|
| “ Starting Motor - Inspect” | 75 |
|-----------------------------|----|

i02578388

i02322311

## Aftercooler Core - Clean/Test (Air-To-Air Aftercooler)

**Note:** Adjust the frequency of cleaning according to the effects of the operating environment.

Inspect the cooling air side of the aftercooler for these items: damaged fins, corrosion, dirt, grease, insects, leaves, oil and other debris. Clean the cooling air side of the aftercooler, if necessary.

For air-to-air aftercoolers, use the same methods that are used for cleaning the outside of radiators.

### **WARNING**

**Personal injury can result from air pressure.**

**Personal injury can result without following proper procedure. When using pressure air, wear a protective face shield and protective clothing.**

**Maximum air pressure at the nozzle must be less than 205 kPa (30 psi) for cleaning purposes.**

Pressurized air is the preferred method for removing loose debris. Hold the nozzle approximately 6 mm (0.25 inch) away from the fins. Slowly move the air nozzle in a direction that is parallel with the tubes. This will remove debris that is between the tubes.

Pressurized water may also be used for cleaning. The maximum water pressure for cleaning purposes must be less than 275 kPa (40 psi). Use pressurized water in order to soften mud.

Use a degreaser and steam for removal of oil and grease. Wash the core with detergent and hot water. Thoroughly rinse the core with clean water.

After cleaning, start the engine. Run the engine for two minutes. This will help in the removal of debris and drying of the core. Stop the engine. Inspect the core for cleanliness. Repeat the cleaning, if necessary.

Inspect the fins for damage. Bent fins may be opened with a "comb".

Inspect these items for good condition: welds, mounting brackets, air lines, connections, clamps and seals. Make repairs, if necessary.

## Alternator - Inspect

Perkins recommends a scheduled inspection of the alternator. Inspect the alternator for loose connections and correct battery charging. Check the ammeter (if equipped) during engine operation in order to ensure correct battery performance and/or correct performance of the electrical system. Make repairs, as required.

Check the alternator and the battery charger for correct operation. If the batteries are correctly charged, the ammeter reading should be very near zero. All batteries should be kept charged. The batteries should be kept warm because temperature affects the cranking power. If the battery is too cold, the battery will not crank the engine. When the engine is not run for long periods of time or if the engine is run for short periods, the batteries may not fully charge. A battery with a low charge will freeze more easily than a battery with a full charge.

i01878164

## Battery - Replace

### **WARNING**

**Batteries give off combustible gases which can explode. A spark can cause the combustible gases to ignite. This can result in severe personal injury or death.**

**Ensure proper ventilation for batteries that are in an enclosure. Follow the proper procedures in order to help prevent electrical arcs and/or sparks near batteries. Do not smoke when batteries are serviced.**

### **WARNING**

**The battery cables or the batteries should not be removed with the battery cover in place. The battery cover should be removed before any servicing is attempted.**

**Removing the battery cables or the batteries with the cover in place may cause a battery explosion resulting in personal injury.**

1. Switch the engine to the OFF position. Remove all electrical loads.
2. Turn off any battery chargers. Disconnect any battery chargers.

Maintenance Section  
Battery Electrolyte Level - Check

3. The NEGATIVE “-” cable connects the NEGATIVE “-” battery terminal to the NEGATIVE “-” terminal on the starter motor. Disconnect the cable from the NEGATIVE “-” battery terminal.
4. The POSITIVE “+” cable connects the POSITIVE “+” battery terminal to the POSITIVE “+” terminal on the starting motor. Disconnect the cable from the POSITIVE “+” battery terminal.

**Note:** Always recycle a battery. Never discard a battery. Return used batteries to an appropriate recycling facility.

5. Remove the used battery.
6. Install the new battery.

**Note:** Before the cables are connected, ensure that the engine start switch is OFF.

7. Connect the cable from the starting motor to the POSITIVE “+” battery terminal.
8. Connect the cable from the NEGATIVE “-” terminal on the starter motor to the NEGATIVE “-” battery terminal.

i02563861

## Battery Electrolyte Level - Check

When the engine is not run for long periods of time or when the engine is run for short periods, the batteries may not fully recharge. Ensure a full charge in order to help prevent the battery from freezing. If batteries are correctly charged, the ammeter reading should be very near zero, when the engine is in operation.

### WARNING

**All lead-acid batteries contain sulfuric acid which can burn the skin and clothing. Always wear a face shield and protective clothing when working on or near batteries.**

1. Remove the filler caps. Maintain the electrolyte level to the “FULL” mark on the battery.  
  
If the addition of water is necessary, use distilled water. If distilled water is not available use clean water that is low in minerals. Do not use artificially softened water.
2. Check the condition of the electrolyte with a suitable battery tester.
3. Install the caps.

4. Keep the batteries clean.

Clean the battery case with one of the following cleaning solutions:

- A mixture of 0.1 kg (0.2 lb) of washing soda or baking soda and 1 L (1 qt) of clean water
- A mixture of 0.1 L (0.11 qt) of ammonia and 1 L (1 qt) of clean water

Thoroughly rinse the battery case with clean water.

Use a fine grade of sandpaper to clean the terminals and the cable clamps. Clean the items until the surfaces are bright or shiny. DO NOT remove material excessively. Excessive removal of material can cause the clamps to not fit properly. Coat the clamps and the terminals with a suitable petroleum jelly.

i08357764

## Battery or Battery Cable - Disconnect

### WARNING

**The battery cables or the batteries should not be removed with the battery cover in place. The battery cover should be removed before any servicing is attempted.**

**Removing the battery cables or the batteries with the cover in place may cause a battery explosion resulting in personal injury.**

1. Turn the start switch to the OFF position. Turn the ignition switch (if equipped) to the OFF position and remove the key and all electrical loads.
2. Disconnect the negative battery terminal at the battery that goes to the start switch. Ensure that the cable cannot contact the terminal. When four 12 volt batteries are involved, the negative side of two batteries must be disconnected.
3. Tape the leads to help prevent accidental starting.
4. Proceed with necessary system repairs. Reverse the steps to reconnect all cables.



i02576025

## Belts - Inspect/Adjust/Replace

### Inspection

Inspect the alternator belt and the fan drive belts for wear and for cracking. Replace the belts if the belts are not in good condition.

Check the belt tension according to the information in Systems Operation, Testing and Adjusting, "Belt Tension Chart".

Slippage of loose belts can reduce the efficiency of the driven components. Vibration of loose belts can cause unnecessary wear on the following components:

- Belts
- Pulleys
- Bearings

If the belts are too tight, unnecessary stress is placed on the components. This reduces the service life of the components.

### Replacement

For applications that require multiple drive belts, replace the drive belts in matched sets. Replacing one drive belt of a matched set will cause the new drive belt to carry more load because the older drive belts are stretched. The additional load on the new drive belt could cause the new drive belt to fail.

### Alternator Belt Adjustment

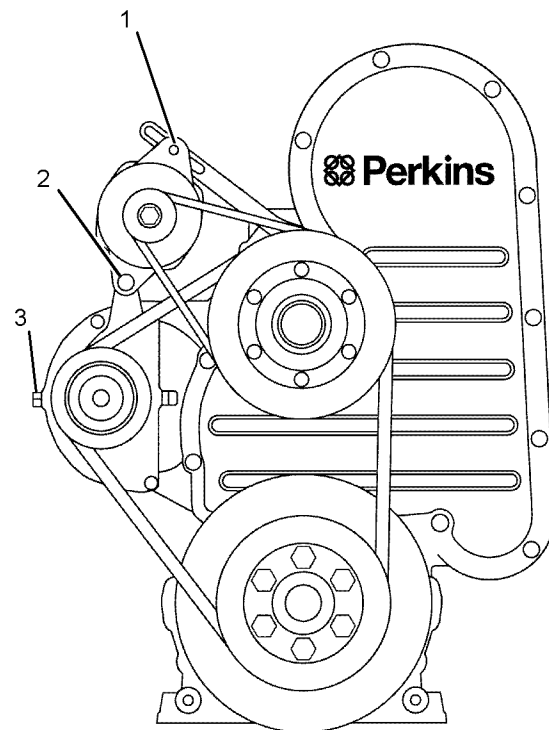

Illustration 23

g01290792

1. Remove the belt guard.
2. Loosen alternator pivot bolt (2) .
3. Loosen the setscrew for the adjustment link which is behind the fan pulley and the setscrew (1).

4. Move the assembly in order to increase or decrease the belt tension. Refer to Systems Operation, Testing and Adjusting, "Belt Tension Chart".
5. Tighten the setscrew for the adjustment link (1). Tighten alternator pivot bolt (2).  
  
Refer to Specifications, "Alternator Mounting" for correct torque.
6. Reinstall the belt guard.  
  
If new alternator belts are installed, check the tension of the alternator belt again after 10 minutes of engine operation at the rated rpm.
7. Remove the belt guard and check the belt tension. When the correct belt tension is obtained, fit the belt guard.

## Adjustment of the Fan Drive Belt

1. Remove the belt guard.
2. Loosen the large locknut and turn the adjustment screw (3) until the correct belt tension is obtained.
3. Tighten the large locknut (3) and recheck the belt tension.
4. If the belt tension is correct, loosen the adjustment screw (3) in order to release the tension.
5. Reinstall the belt guard.  
  
If new alternator belts are installed, check the tension of the alternator belt again after 10 minutes of engine operation at the rated rpm.
6. Remove the belt guard and check the belt tension. When the correct belt tension is obtained, fit the belt guard.

i02579635

## Cooling System Coolant (ELC) - Change

---

### NOTICE

Care must be taken to ensure that fluids are contained during performance of inspection, maintenance, testing, adjusting and repair of the product. Be prepared to collect the fluid with suitable containers before opening any compartment or disassembling any component containing fluids.

Dispose of all fluids according to Local regulations and mandates.

---

### NOTICE

Keep all parts clean from contaminants.

Contaminants may cause rapid wear and shortened component life.

---

Clean the cooling system and flush the cooling system before the recommended maintenance interval if the following conditions exist:

- The engine overheats frequently.
- Foaming of the coolant is observed.
- The oil has entered the cooling system and the coolant is contaminated.
- The fuel has entered the cooling system and the coolant is contaminated.

**Note:** When the cooling system is cleaned, only clean water is needed when the ELC is drained and replaced.

**Note:** Inspect the water pump and the water temperature regulator after the cooling system has been drained. This is a good opportunity to replace the water pump, the water temperature regulator and the hoses, if necessary.

## Drain

### WARNING

**Pressurized System: Hot coolant can cause serious burns. To open the cooling system filler cap, stop the engine and wait until the cooling system components are cool. Loosen the cooling system pressure cap slowly in order to relieve the pressure.**

---

1. Stop the engine and allow the engine to cool. Loosen the cooling system filler cap slowly in order to relieve any pressure. Remove the cooling system filler cap.
  2. Open the drain cock or remove the drain plug on the radiator.  
  
Allow the coolant to drain.
- 

### NOTICE

Dispose of used engine coolant or recycle. Various methods have been proposed to reclaim used coolant for reuse in engine cooling systems. The full distillation procedure is the only method acceptable by Perkins to reclaim the coolant.

---

For information regarding the disposal and the recycling of used coolant, consult your Perkins dealer or your Perkins distributor.

## Flush

1. Flush the cooling system with clean water in order to remove any debris.
2. Close the drain cock or install the drain plug on the radiator.

### NOTICE

Do not fill the cooling system faster than 5 L (1.3 US gal) per minute to avoid air locks.

Cooling system air locks may result in engine damage.

3. Fill the cooling system with clean water. Install the cooling system filler cap.
4. Start and run the engine until the water temperature regulator opens and the fluid levels decrease in the header tank.
5. Stop the engine and allow the engine to cool. Loosen the cooling system filler cap slowly in order to relieve any pressure. Remove the cooling system filler cap. Open the drain cock or remove the drain plug on the radiator. Allow the water to drain. Flush the cooling system with clean water.

## Fill

1. Close the drain cock or install the drain plug on the radiator.

### NOTICE

Do not fill the cooling system faster than 5 L (1.3 US gal) per minute to avoid air locks.

Cooling system air locks may result in engine damage.

2. Fill the cooling system with Extended Life Coolant (ELC). Refer to the Operation and Maintenance Manual, "Fluid Recommendations" topic (Maintenance Section) for more information on cooling system specifications. Do not install the cooling system filler cap.
3. Start and run the engine for one minute in order to purge the air from the cavities of the engine block. Stop the engine.

4. Check the coolant level. Maintain the coolant level within 13 mm (0.5 inch) below the bottom of the pipe for filling. If necessary, repeat step 3. Maintain the coolant level in the expansion bottle (if equipped) at the correct level.

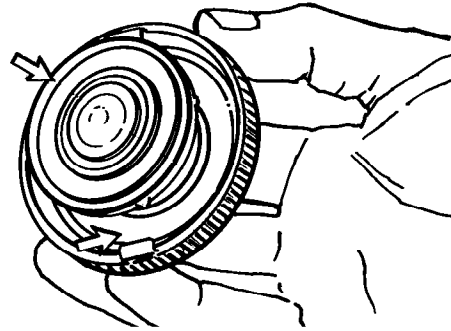

Illustration 24

g00103639

Filler cap

5. Clean the cooling system filler cap and inspect the gasket. If the gasket is damaged, discard the old filler cap and install a new filler cap. If the gasket is not damaged, use a suitable pressurizing pump in order to pressure test the filler cap. The correct pressure is stamped on the face of the filler cap. If the filler cap does not retain the correct pressure, install a new filler cap.
6. Start the engine. Inspect the cooling system for leaks and for correct operating temperature.

i01197583

## Cooling System Coolant Level - Check

Check the coolant level when the engine is stopped and cool.

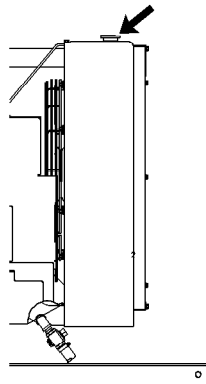

i02573904

## Cooling System Water Temperature Regulator - Replace

Replace the water temperature regulator before the water temperature regulator fails. This is a recommended preventive maintenance practice. Replacing the water temperature regulator reduces the chances for unscheduled downtime.

A water temperature regulator that fails in a partially opened position can cause overheating or overcooling of the engine.

A water temperature regulator that fails in the closed position can cause excessive overheating. Excessive overheating could result in cracking of the cylinder head or piston seizure problems.

A water temperature regulator that fails in the open position will cause the engine operating temperature to be too low during partial load operation. Low engine operating temperatures during partial loads could cause an excessive carbon buildup inside the cylinders. This excessive carbon buildup could result in an accelerated wear of the piston rings and wear of the cylinder liner.

Refer to Disassembly and Assembly, "Water Temperature Regulator Housing - Remove and Install" for the replacement procedure of the water temperature regulator, or consult your Perkins distributor.

**Note:** If only the water temperature regulators are replaced, drain the coolant from the cooling system to a level that is below the water temperature regulator housing.

i02573905

## Crankshaft Vibration Damper - Inspect

Damage to the crankshaft vibration damper or failure of the crankshaft vibration damper can increase torsional vibrations. This can result in damage to the crankshaft and to other engine components. A damper that is damaged can cause excessive gear train noise at variable points in the speed range.

The damper is mounted to the crankshaft which is located behind the belt guard on the front of the engine.

Illustration 25

g00285520

Cooling system filler cap

### WARNING

**Pressurized System: Hot coolant can cause serious burns. To open the cooling system filler cap, stop the engine and wait until the cooling system components are cool. Loosen the cooling system pressure cap slowly in order to relieve the pressure.**

1. Remove the cooling system filler cap slowly in order to relieve pressure.
2. Maintain the coolant level within 13 mm (0.5 inch) of the bottom of the filler pipe. If the engine is equipped with a sight glass, maintain the coolant level to the proper level in the sight glass.

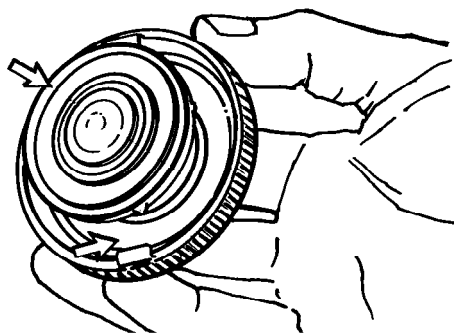

Illustration 26

g00103639

Typical filler cap gaskets

3. Clean the cooling system filler cap and check the condition of the filler cap gaskets. Replace the cooling system filler cap if the filler cap gaskets are damaged. Reinstall the cooling system filler cap.
4. Inspect the cooling system for leaks.

## Visconic Damper

i02568145

The visconic damper has a weight that is located inside a fluid filled case. The weight moves in the case in order to limit torsional vibration.

Inspect the damper for evidence of fluid leaks. If a fluid leak is found, determine the type of fluid. The fluid in the damper is silicone. Silicone has the following characteristics: transparent, viscous and smooth.

If the fluid leak is oil, inspect the crankshaft seals for leaks. If a leak is observed, replace the crankshaft seals.

Inspect the damper and repair or replace the damper for any of the following reasons:

- The damper is dented, cracked, or leaking.
- The paint on the damper is discolored from heat.
- The engine has had a failure because of a broken crankshaft.
- Analysis of the oil has revealed that the front main bearing is badly worn.
- There is a large amount of gear train wear that is not caused by a lack of oil.
- The temperature of the damper fluid is too high.

Refer to the Service Manual or consult your Perkins distributor for information about damper replacement.

i02151646

## Driven Equipment - Check

Refer to the OEM specifications for more information on the following maintenance recommendations for the driven equipment:

- Inspection
- Adjustment
- Lubrication
- Other maintenance recommendations

Perform any maintenance for the driven equipment which is recommended by the OEM.

## Electronic Unit Injector - Inspect/Adjust

### WARNING

**Be sure the engine cannot be started while this maintenance is being performed. To prevent possible injury, do not use the starting motor to turn the flywheel.**

**Hot engine components can cause burns. Allow additional time for the engine to cool before measuring/adjusting the unit injectors.**

**The electronic unit injectors use high voltage. Disconnect the unit injector enable circuit connector in order to prevent personal injury. Do not come in contact with the injector terminals while the engine is running.**

The operation of Perkins engines with improper adjustments of the electronic unit injector can reduce engine efficiency. This reduced efficiency could result in excessive fuel usage and/or shortened engine component life.

Only qualified service personnel should perform this maintenance. Refer to the following topics for your engine for the correct procedure: Refer to the Systems Operation, Testing and Adjusting, "Electronic Unit Injector - Test" for the test procedure, and Systems Operation, Testing and Adjusting, "Electronic Unit Injector - Adjust" for the correct procedure for adjusting the injectors.

### NOTICE

The camshafts must be correctly timed with the crankshaft before an adjustment of the lash for the fuel injector is made. The timing pins must be removed from the camshafts before the crankshaft is turned or damage to the cylinder block will be the result.

i02568158

## Engine - Clean

### WARNING

**Personal injury or death can result from high voltage.**

**Moisture can create paths of electrical conductivity.**

**Make sure that the electrical system is OFF. Lock out the starting controls and tag the controls "DO NOT OPERATE" .**

### NOTICE

Accumulated grease and oil on an engine is a fire hazard. Keep the engine clean. Remove debris and fluid spills whenever a significant quantity accumulates on the engine.

Periodic cleaning of the engine is recommended. Steam cleaning the engine will remove accumulated oil and grease. A clean engine provides the following benefits:

- Easy detection of fluid leaks
- Maximum heat transfer characteristics
- Ease of maintenance

**Note:** Caution must be used in order to prevent electrical components from being damaged by excessive water when you clean the engine. Avoid electrical components such as the alternator, the starter, and the Electronic Control Module (ECM).

i02570750

## Engine Air Cleaner Element (Single Element) - Inspect/Replace

Refer to Operation and Maintenance Manual, "Engine Air Cleaner Service Indicator-Inspect".

### NOTICE

Never run the engine without an air cleaner element installed. Never run the engine with a damaged air cleaner element. Do not use air cleaner elements with damaged pleats, gaskets or seals. Dirt entering the engine causes premature wear and damage to engine components. Air cleaner elements help to prevent airborne debris from entering the air inlet.

### NOTICE

Never service the air cleaner element with the engine running since this will allow dirt to enter the engine.

## Servicing the Air Cleaner Element

**Note:** The air filter system may not have been provided by Perkins. The procedure that follows is for a typical air filter system. Refer to the OEM information for the correct procedure.

If the air cleaner element becomes plugged, the air can split the material of the air cleaner element. Unfiltered air will drastically accelerate internal engine wear. Refer to the OEM information for the correct air cleaner elements for your application.

- Check the precleaner (if equipped) and the dust bowl (if equipped) daily for accumulation of dirt and debris. Remove any dirt and debris, as needed.
- Operating in dirty conditions may require more frequent service of the air cleaner element.
- The air cleaner element should be replaced at least one time per year. This replacement should be performed regardless of the number of cleanings.

Replace the dirty air cleaner elements with clean air cleaner elements. Before installation, the air cleaner elements should be thoroughly checked for tears and/or holes in the filter material. Inspect the gasket or the seal of the air cleaner element for damage. Maintain a supply of suitable air cleaner elements for replacement purposes.

## Cleaning the Air Cleaner Element

Refer to the OEM information in order to determine the number of times that the air filter element can be cleaned. When the air cleaner element is cleaned, check for rips or tears in the filter material. The air cleaner element should be replaced at least one time per year. This replacement should be performed regardless of the number of cleanings.

### NOTICE

Do not tap or strike the air cleaner element.

Do not wash the primary air cleaner element.

Use low pressure (207 kPa; 30 psi maximum) pressurised air or vacuum cleaning to clean the primary air cleaner element.

Take extreme care in order to avoid damage to the air cleaner elements.

Do not use air cleaner elements that have damaged pleats, gaskets or seals.

Refer to the OEM information in order to determine the number of times that the air cleaner element can be cleaned. Do not clean the air filter element more than three times. The air cleaner element must be replaced at least one time per year.

Cleaning the air filter element will not extend the life of the air filter element.

Visually inspect the air cleaner element before cleaning. Inspect air cleaner elements for damage to the pleats, the seals, the gaskets and the outer cover. Discard any damaged air cleaner element.

Two methods may be used in order to clean the air cleaner element:

- Pressurized air
- Vacuum cleaning

### Pressurized Air

#### **WARNING**

Personal injury can result from air pressure.

Personal injury can result without following proper procedure. When using pressure air, wear a protective face shield and protective clothing.

Maximum air pressure at the nozzle must be less than 205 kPa (30 psi) for cleaning purposes.

Pressurized air can be used to clean primary air cleaner elements that have not been cleaned more than three times. Use filtered, dry air with a maximum pressure of 207 kPa (30 psi). Pressurized air will not remove deposits of carbon and oil.

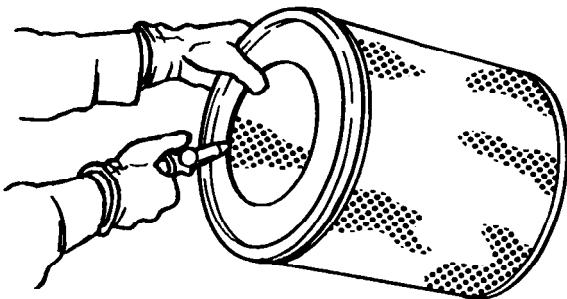

Illustration 27

g00281692

**Note:** When the air cleaner element is cleaned, always begin with the clean side (inside) in order to force dirt particles toward the dirty side (outside).

Aim the air hose so that air flows along the length of the filter. Follow the direction of the paper pleats in order to prevent damage to the pleats. Do not aim the air directly at the face of the paper pleats.

**Note:** Refer to “Inspecting the Air Cleaner Element”.

### Vacuum Cleaning

Vacuum cleaning is a good method for removing accumulated dirt from the dirty side (outside) of an air cleaner element. Vacuum cleaning is especially useful for cleaning the air cleaner element that will require daily cleaning because of a dry, dusty environment.

Cleaning from the clean side (inside) with pressurized air is recommended prior to vacuum cleaning the dirty side (outside) of an air cleaner element.

**Note:** Refer to “Inspecting the Air Cleaner Element”.

### Inspecting the Air Cleaner Element

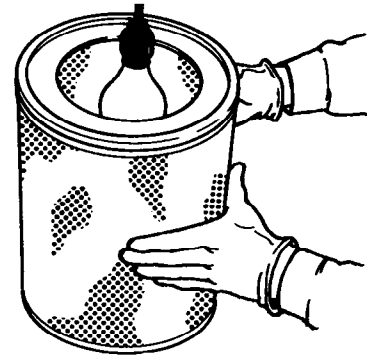

Illustration 28

g00281693

Inspect the clean, dry air cleaner element. Use a 60 watt blue light in a dark room or in a similar facility. Place the blue light in the air cleaner element. Rotate the air cleaner element. Inspect the air cleaner element for tears and/or holes. Inspect the air cleaner element for light that may show through the filter material. If it is necessary in order to confirm the result, compare the air cleaner element to a new air cleaner element that has the same part number.

Do not use a air cleaner element that has any tears and/or holes in the filter material. Do not use an air cleaner element with damaged pleats, gaskets or seals. Discard damaged air cleaner elements.

i02568159

## Engine Air Cleaner Service Indicator - Inspect (If Equipped)

Some engines may be equipped with a different service indicator.

Maintenance Section  
Engine Crankcase Breather - Replace

Some engines are equipped with a differential gauge for inlet air pressure. The differential gauge for inlet air pressure displays the difference in the pressure that is measured before the air cleaner element and the pressure that is measured after the air cleaner element. As the air cleaner element becomes dirty, the pressure differential rises. If your engine is equipped with a different type of service indicator, follow the OEM recommendations in order to service the air cleaner service indicator.

The service indicator may be mounted on the air cleaner housing or in a remote location.

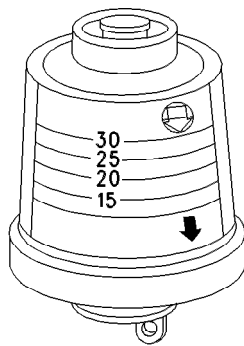

Illustration 29

g00103777

Typical service indicator

Observe the service indicator. The air cleaner element should be cleaned or the air cleaner element should be replaced when the following condition occurs:

- The red piston locks in the visible position.

## Engine Crankcase Breather - Replace

i02583379

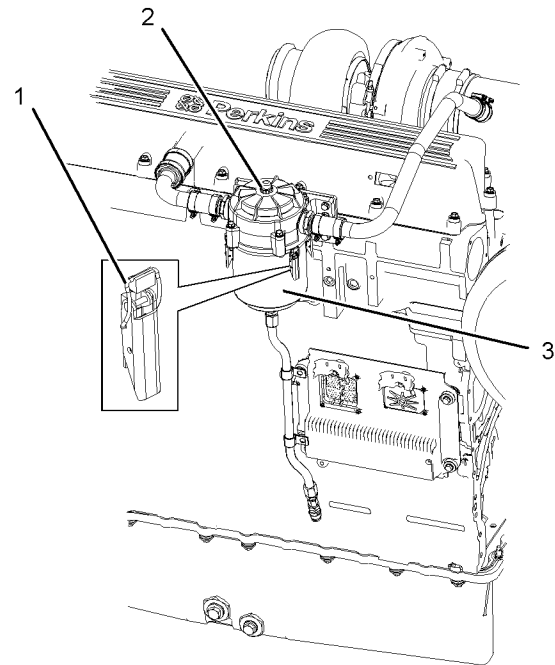

Illustration 30

g01289451

Typical example

### NOTICE

Ensure that the components of the breather assembly are installed in the correct position. If installed incorrectly, engine damage can result.

1. Remove all dirt and oil from the outside of the breather assembly. Unlatch the four clips (1) that secure the top cover (2). Remove the top cover (2). The breather element includes an O ring. Remove the breather element by turning and lifting the element. Discard the element. Clean the inner surfaces of the breather body (3). Clean the top cover (2) and inspect the O ring in the top cover (2). If the O ring in the top cover is worn or damaged, replace the O ring.



- Lubricate the O ring in the new filter element with clean engine lubricating oil. Carefully insert the element into the breather body (3). Lubricate the O ring in the top cover (2) with clean engine lubricating oil. Carefully insert the top cover (2) onto the breather body (3). Secure the top cover (2) in position by fastening the four clips (1) into the correct position.

i07819538

## Engine Mounts - Inspect

**Note:** The engine mounts may not have been supplied by Perkins. Refer to the Original Equipment Manufacturer (OEM) information for further details on the engine mounts and the correct bolt torque.

Inspect the engine mounts for deterioration and for correct bolt torque. Excessive engine vibration can be caused by the following conditions:

- Incorrect mounting of the engine
- Deterioration of the engine mounts
- Loose engine mounts

Any engine mount that shows deterioration should be replaced. Refer to the OEM information for the recommended torques.

When the engine mounts are supplied by Perkins the maintenance procedure will be supplied in the Disassembly and Assembly manual for your engine.

i02570749

## Engine Oil Level - Check

### WARNING

Hot oil and hot components can cause personal injury. Do not allow hot oil or hot components to contact the skin.

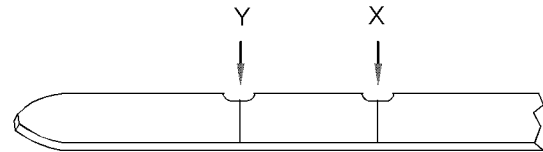

Illustration 31

g01165836

(Y) "Low" mark. (X) "High" mark.

### NOTICE

Perform this maintenance with the engine stopped.

**Note:** Ensure that the engine is either level or that the engine is in the normal operating position in order to obtain a true level indication.

**Note:** After the engine has been switched OFF, wait for ten minutes in order to allow the engine oil to drain to the oil pan before checking the oil level.

- Maintain the oil level between the "Low" mark (Y) and the "High" mark (X) on the engine oil dipstick. Do not fill the crankcase above the "High" mark (X).

### NOTICE

Operating your engine when the oil level is above the "High" mark could cause your crankshaft to dip into the oil. The air bubbles created from the crankshaft dipping into the oil reduces the oil's lubricating characteristics and could result in the loss of power.

- Remove the oil filler cap and add oil, if necessary. Clean the oil filler cap. Install the oil filler cap.

i01907674

## Engine Oil Sample - Obtain

The condition of the engine lubricating oil may be checked at regular intervals as part of a preventive maintenance program. Perkins include an oil sampling valve as an option. The oil sampling valve (if equipped) is included in order to regularly sample the engine lubricating oil. The oil sampling valve is positioned on the oil filter head or the oil sampling valve is positioned on the cylinder block.

Perkins recommends using a sampling valve in order to obtain oil samples. The quality and the consistency of the samples are better when a sampling valve is used. The location of the sampling valve allows oil that is flowing under pressure to be obtained during normal engine operation.

## Obtain the Sample and the Analysis

### WARNING

**Hot oil and hot components can cause personal injury. Do not allow hot oil or hot components to contact the skin.**

In order to help obtain the most accurate analysis, record the following information before an oil sample is taken:

- The date of the sample
- Engine model
- Engine number
- Service hours on the engine
- The number of hours that have accumulated since the last oil change
- The amount of oil that has been added since the last oil change

Ensure that the container for the sample is clean and dry. Also ensure that the container for the sample is clearly labelled.

To ensure that the sample is representative of the oil in the crankcase, obtain a warm, well mixed oil sample.

To avoid contamination of the oil samples, the tools and the supplies that are used for obtaining oil samples must be clean.

The sample can be checked for the following: the quality of the oil, the existence of any coolant in the oil, the existence of any ferrous metal particles in the oil and the existence of any nonferrous metal particles in the oil.

i02570777

## Engine Oil and Filter - Change

### WARNING

**Hot oil and hot components can cause personal injury. Do not allow hot oil or hot components to contact the skin.**

Do not drain the oil when the engine is cold. As the oil cools, suspended waste particles settle on the bottom of the oil pan. The waste particles are not removed with the draining cold oil. Drain the crankcase with the engine stopped. Drain the crankcase with the oil warm. This draining method allows the waste particles that are suspended in the oil to be drained properly.

Failure to follow this recommended procedure will cause the waste particles to be recirculated through the engine lubrication system with the new oil.

## Drain the Engine Oil

After the engine has been run at the normal operating temperature, stop the engine. Use one of the following methods to drain the engine crankcase oil:

- If the engine is equipped with a drain valve, turn the drain valve knob counterclockwise in order to drain the oil. After the oil has drained, turn the drain valve knob clockwise in order to close the drain valve.
- If the engine is not equipped with a drain valve, remove the oil drain plug in order to allow the oil to drain. Discard the washer. If the engine is equipped with a shallow sump, remove the bottom oil drain plugs from both ends of the oil pan.

After the oil has drained, the oil drain plug should be cleaned. Install a new washer to the oil drain plug. Reinstall the oil drain plug.

## Replace the Oil Filter

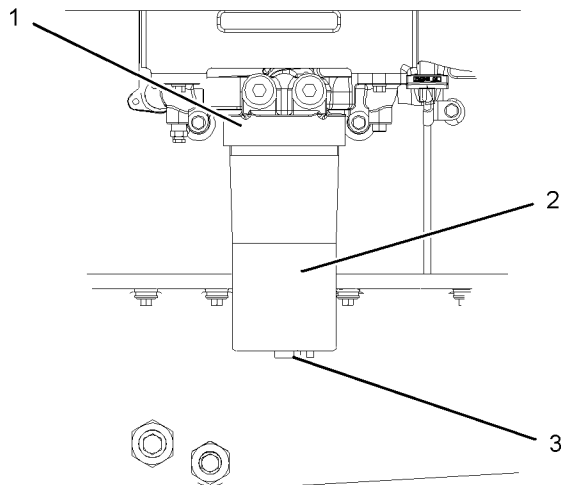

Illustration 32

g01289998

### Typical example

1. Remove the oil filter housing (2) from the oil filter base (1). Remove the O-ring from the oil filter housing (2). Discard the O-ring.
2. Remove the oil filter element from the oil filter housing (2).
3. Cut the oil filter open with a suitable tool. Break apart the pleats and inspect the oil filter for metal debris. An excessive amount of metal debris in the oil filter may indicate early wear or a pending failure.

Use a magnet to differentiate between the ferrous metals and the nonferrous metals that are found in the oil filter element. Ferrous metals may indicate wear on the steel and cast iron parts of the engine.

Nonferrous metals may indicate wear on the aluminum parts, brass parts or bronze parts of the engine. Parts that may be affected include the following items: main bearings, rod bearings, turbocharger bearings and cylinder heads.

Due to normal wear and friction, it is not uncommon to find small amounts of debris in the oil filter. Consult your Perkins distributor in order to arrange for a further analysis if an excessive amount of debris is found in the oil filter.

4. Clean the sealing surface of the oil filter base (1). Clean the oil filter housing (2). Clean the drain plug (3).
5. Install a new O-ring to the drain plug (3). Install the drain plug (3) to the oil filter housing (2).

### NOTICE

Do not fill the oil filters with oil before installing them. This oil would not be filtered and could be contaminated. Contaminated oil can cause accelerated wear to engine components.

6. Install a new oil filter to the oil filter housing (2). Install a new O-ring to the oil filter housing (2).
7. Install the oil filter housing (2) to the oil filter base (1). Tighten the oil filter housing (2) to a torque of 90 N·m (66 lb ft).

## Fill the Engine Crankcase

1. Remove the oil filler cap. Refill the engine crankcase with engine oil. Refer to the Operation and Maintenance Manual, "Refill Capacities" and Operation and Maintenance Manual, "Fluid recommendations" for more information.

### NOTICE

If equipped with an auxiliary oil filter system or a remote oil filter system, follow the OEM or filter manufacturer's recommendations. Under filling or overfilling the crankcase with oil can cause engine damage.

### NOTICE

To prevent crankshaft bearing damage, crank the engine with the fuel OFF. This will fill the oil filters before starting the engine. Do not crank the engine for more than 30 seconds.

2. Start the engine and run the engine for two minutes. Perform this procedure in order to ensure that the lubrication system has oil and that the oil filters are filled. Inspect the oil filter for oil leaks.
3. Stop the engine and allow the oil to drain back to the sump for a minimum of ten minutes.

- Remove the oil level gauge in order to check the oil level. Maintain the oil level between the "Low" and "High" marks on the oil level gauge.

i02568161

## Engine Protective Devices - Check

### Visual Inspection

Visually check the condition of all gauges, sensors and wiring. Look for wiring and components that are loose, broken, or damaged. Damaged wiring or components should be repaired or replaced immediately.

### Calibration Check

#### NOTICE

During testing, abnormal operating conditions must be simulated.

The tests must be performed correctly in order to prevent possible damage to the engine.

Alarms and shutoffs must function properly. Alarms provide timely warning to the operator. Shutoffs help to prevent damage to the engine. It is impossible to determine if the engine protective devices are in good working order during normal operation. Malfunctions must be simulated in order to test the engine protective devices. To prevent damage to the engine, only authorized service personnel or your Perkins distributor should perform the tests.

Consult your Perkins distributor or refer to the Service Manual for more information.

i02568182

## Engine Speed/Timing Sensors - Check/Clean/Calibrate

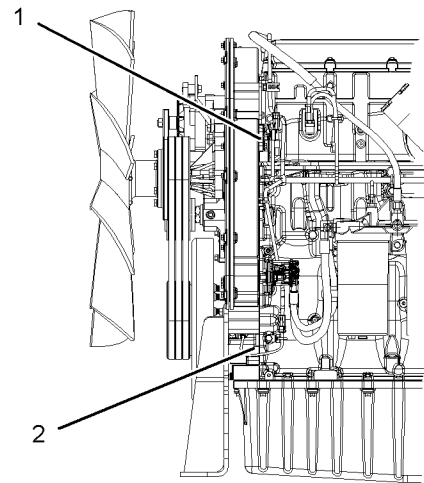

Illustration 33

g01286455

#### Left side view

- (1) Camshaft position sensor  
 (2) Crankshaft position sensor

- Remove the speed/timing sensors from the front housing. Check the condition of the plastic end of the speed/timing sensors for wear and/or contaminants.
- Clean the metal shavings and other debris from the face of the speed/timing sensors. Use the procedure in the Service Manual in order to calibrate the speed/timing sensors.

Refer to the Troubleshooting, "Calibration Procedures" for more information on the speed/timing sensors.

i02568163

i02568747

## Engine Valve Lash - Inspect/Adjust

The initial valve lash adjustment on new engines, rebuilt engines, or remanufactured engines is recommended at the first scheduled oil change. The adjustment is necessary due to the initial wear of the valve train components and to the seating of the valve train components.

This maintenance is recommended by Perkins as part of a lubrication and preventive maintenance schedule in order to help provide maximum engine life.

### NOTICE

Only qualified service personnel should perform this maintenance. Refer to the Service Manual or your authorized Perkins dealer or your Perkins distributor for the complete valve lash adjustment procedure.

Operation of Perkins engines with incorrect valve lash can reduce engine efficiency, and also reduce engine component life.

### WARNING

Ensure that the engine can not be started while this maintenance is being performed. To help prevent possible injury, do not use the starting motor to turn the flywheel.

Hot engine components can cause burns. Allow additional time for the engine to cool before measuring/adjusting valve lash clearance.

Ensure that the engine is stopped before measuring the valve lash. To obtain an accurate measurement, allow the valves to cool before this maintenance is performed.

The following components should be inspected and adjusted when the valves are inspected and adjusted.

- Valve actuators
- Injectors

Refer to Systems Operation, Testing and Adjusting, "Engine Valve Lash - Inspect/Adjust" for more information.

## Fuel System - Prime

### NOTICE

Use a suitable container to catch any fuel that might spill. Clean up any spilled fuel immediately.

### NOTICE

Do not allow dirt to enter the fuel system. Thoroughly clean the area around a fuel system component that will be disconnected. Fit a suitable cover over disconnected fuel system component.

**Note:** This procedure is most common when the engine has run out of fuel.

1. Turn the ignition switch to the "OFF" position.
2. Fill the fuel tank(s) with clean diesel fuel.

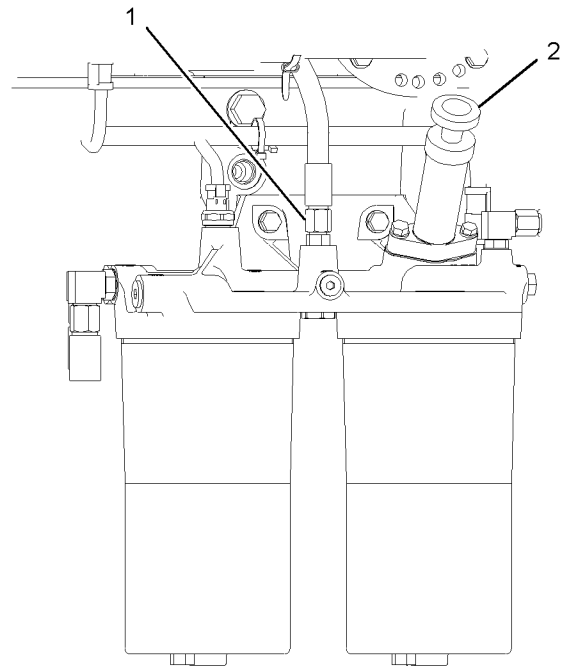

Illustration 34

g01282239

Typical example

3. Loosen the union of the pipe for the fuel(1).

**Note:** Do not remove the union completely. Open the union enough to allow the air that is trapped in the cylinder head to be purged from the fuel system.

4. Unlock and operate the hand priming pump (2).  
 Use a suitable container to collect excess fuel.
5. Tighten the union of the pipe for the fuel (1).
6. Operate the hand priming pump until a strong pressure is felt on the pump. Push the priming pump plunger inward. Tighten the plunger by hand and start the engine.

---

**NOTICE**

Do not crank the engine continuously for more than 30 seconds. Allow the starting motor to cool for 30 seconds before cranking the engine again.

---

7. If the engine will not start, allow the starting motor to cool for 30 seconds. Repeat steps 3 to 6 in order to operate the engine.
8. Continue to eliminate air from the fuel system if these events occur:
  - The engine starts, but the engine does not run evenly.
  - The engine starts, but the engine continues to misfire or smoke.
9. Run the engine with no load until the engine runs smoothly.

i02570752

## Fuel System Primary Filter/ Water Separator - Drain

**⚠ WARNING**

Fuel leaked or spilled onto hot surfaces or electrical components can cause a fire. To help prevent possible injury, turn the start switch off when changing fuel filters or water separator elements. Clean up fuel spills immediately.

---

**NOTICE**

The water separator is not a filter. The water separator separates water from the fuel. The engine should never be allowed to run with the water separator more than half full. Engine damage may result.

---

**NOTICE**

The water separator is under suction during normal engine operation. Ensure that the drain valve is tightened securely to help prevent air from entering the fuel system.

---

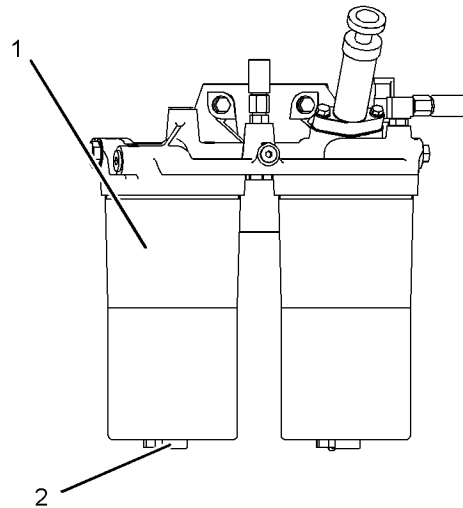

Illustration 35

g01287852

Typical example

1. Place a suitable container below the primary fuel filter assembly (1).
2. Open the drain (2). Allow the fluid to drain into the container.
3. When clean fuel drains from the primary fuel filter assembly (1) close the drain (2). Tighten the drain (2) by hand pressure only. Dispose of the drained fluid correctly.

i02570756

## Fuel System Primary Filter (Water Separator) Element - Replace

**⚠ WARNING**

Fuel leaked or spilled onto hot surfaces or electrical components can cause a fire. To help prevent possible injury, turn the start switch off when changing fuel filters or water separator elements. Clean up fuel spills immediately.

---

**NOTICE**

Do not allow dirt to enter the fuel system. Thoroughly clean the area around a fuel system component that will be disconnected. Fit a suitable cover over disconnected fuel system component.

---

i02570757

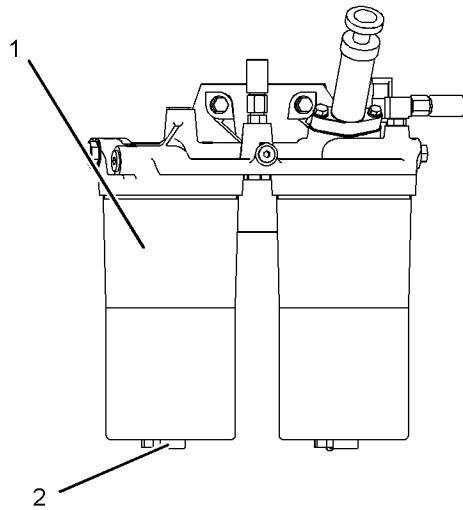

Illustration 36

g01287852

1. Turn the fuel supply valve (if equipped) to the OFF position.
2. Place a suitable container under the primary fuel filter assembly (1). Clean the outside of the primary fuel filter assembly (1).
3. Remove the drain plug (2). Allow the fluid to drain into the container.
4. Remove the primary fuel filter assembly (1) from the fuel filter base. Remove the O-ring. Discard the O-ring. Remove the primary fuel filter element from the primary fuel filter housing.
5. Clean the contact face of the fuel filter base with clean engine oil.
6. Install a new primary fuel filter element to the primary fuel filter housing. Install a new O-ring seal to the primary fuel filter housing. Install the primary fuel filter assembly (1) to the fuel filter base. Tighten the primary fuel filter assembly (1) to a torque of 80 N·m (59 lb ft).
7. Install a new O-ring to the drain plug (2).
8. Install the drain plug (2) to the primary fuel filter assembly (1).
9. Remove the container and dispose of the fuel safely.
10. Turn the fuel supply valve (if equipped) to the ON position.
11. Prime the fuel system. Refer to the Operation and Maintenance Manual, "Fuel System - Prime" for more information.

## Fuel System Secondary Filter - Replace

### WARNING

Fuel leaked or spilled onto hot surfaces or electrical components can cause a fire. To help prevent possible injury, turn the start switch off when changing fuel filters or water separator elements. Clean up fuel spills immediately.

### NOTICE

Do not allow dirt to enter the fuel system. Thoroughly clean the area around a fuel system component that will be disconnected. Fit a suitable cover over disconnected fuel system component.

Turn the valves for the fuel lines (if equipped) to the OFF position before performing this maintenance. Place a tray under the fuel filter in order to catch any fuel that might spill. Clean up any spilled fuel immediately.

1. Close the valves for the fuel lines (if equipped).

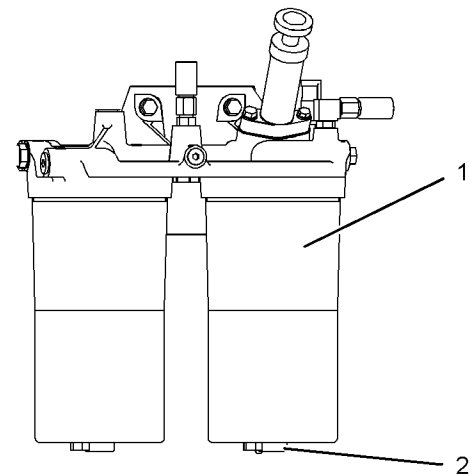

Illustration 37

g01287859

2. Clean the outside of the secondary fuel filter assembly (1). Open the drain plug (2) and drain the fuel into a suitable container.
3. Remove the O-ring from the drain plug (2). Discard the O-ring.
4. Remove the secondary fuel filter assembly (1) from the fuel filter base.

5. Remove the O-ring from the secondary fuel filter assembly.
6. Remove the secondary fuel filter element from the secondary fuel filter housing. Discard the secondary fuel filter element.
7. Clean the secondary fuel filter housing with clean engine oil. Clean the contact face of the fuel filter base with clean engine oil.
8. Install a new secondary fuel filter element to the secondary fuel filter housing.
9. Install a new O-ring to the secondary fuel filter assembly (1).
10. Install the secondary fuel filter assembly (1) to the fuel filter base. Tighten the secondary fuel filter assembly (1) to a torque of 80 N·m (59 lb ft).
11. Install a new O-ring to the drain plug (2). Install the drain plug (2) to the secondary fuel filter assembly (1).
12. Turn the valves for the fuel lines (if equipped) to the ON position.
13. If necessary, prime the fuel system. Refer to the Operation and Maintenance Manual, "Fuel System - Prime" for more information.

i02568194

## Fuel Tank Water and Sediment - Drain

---

### NOTICE

Care must be taken to ensure that fluids are contained during performance of inspection, maintenance, testing, adjusting and repair of the product. Be prepared to collect the fluid with suitable containers before opening any compartment or disassembling any component containing fluids.

Dispose of all fluids according to local regulations and mandates.

---

## Fuel Tank

Fuel quality is critical to the performance and to the service life of the engine. Water in the fuel can cause excessive wear to the fuel system.

Water can be introduced into the fuel tank when the fuel tank is being filled.

Condensation occurs during the heating and cooling of fuel. The condensation occurs as the fuel passes through the fuel system and the fuel returns to the fuel tank. This causes water to accumulate in fuel tanks. Draining the fuel tank regularly and obtaining fuel from reliable sources can help to eliminate water in the fuel.

## Drain the Water and the Sediment

Fuel tanks should contain some provision for draining water and draining sediment from the bottom of the fuel tanks.

Open the drain valve on the bottom of the fuel tank in order to drain the water and the sediment. Close the drain valve.

Check the fuel daily. Allow five minutes after the fuel tank has been filled before draining water and sediment from the fuel tank.

Fill the fuel tank after operating the engine in order to drive out moist air. This will help prevent condensation. Do not fill the tank to the top. The fuel expands as the fuel gets warm. The tank may overflow.

Some fuel tanks use supply pipes that allow water and sediment to settle below the end of the fuel supply pipe. Some fuel tanks use supply lines that take fuel directly from the bottom of the tank. If the engine is equipped with this system, regular maintenance of the fuel system filter is important.

## Fuel Storage Tanks

Drain the water and the sediment from the fuel storage tank at the following intervals:

- Service intervals
- Refill of the tank

This will help prevent water or sediment from being pumped from the storage tank into the engine fuel tank.

If a bulk storage tank has been refilled or moved recently, allow adequate time for the sediment to settle before filling the engine fuel tank. Internal baffles in the bulk storage tank will also help trap sediment. Filtering fuel that is pumped from the storage tank helps to ensure the quality of the fuel. When possible, water separators should be used.

i02568190

## Hoses and Clamps - Inspect/Replace

Inspect all hoses for leaks that are caused by the following conditions:



- Cracking
- Softness
- Loose clamps

Replace hoses that are cracked or soft. Tighten any loose clamps.

#### NOTICE

Do not bend or strike high pressure lines. Do not install bent or damaged lines, tubes or hoses. Repair any loose or damaged fuel and oil lines, tubes and hoses. Leaks can cause fires. Inspect all lines, tubes and hoses carefully. Tighten all connections to the recommended torque.

Check for the following conditions:

- End fittings that are damaged or leaking
- Outer covering that is chafed or cut
- Exposed wire that is used for reinforcement
- Outer covering that is ballooning locally
- Flexible part of the hose that is kinked or crushed
- Armoring that is embedded in the outer covering

A constant torque hose clamp can be used in place of any standard hose clamp. Ensure that the constant torque hose clamp is the same size as the standard clamp.

Due to extreme temperature changes, the hose will heat set. Heat setting causes hose clamps to loosen. This can result in leaks. A constant torque hose clamp will help to prevent loose hose clamps.

Each installation application can be different. The differences depend on the following factors:

- Type of hose
- Type of fitting material
- Anticipated expansion and contraction of the hose
- Anticipated expansion and contraction of the fittings

## Replace the Hoses and the Clamps

### WARNING

**Pressurized System:** Hot coolant can cause serious burns. To open the cooling system filler cap, stop the engine and wait until the cooling system components are cool. Loosen the cooling system pressure cap slowly in order to relieve the pressure.

1. Stop the engine. Allow the engine to cool.
2. Loosen the cooling system filler cap slowly in order to relieve any pressure. Remove the cooling system filler cap.

**Note:** Drain the coolant into a suitable, clean container. The coolant can be reused.

3. Drain the coolant from the cooling system to a level that is below the hose that is being replaced.
4. Remove the hose clamps.
5. Disconnect the old hose.
6. Replace the old hose with a new hose.
7. Install the hose clamps.
8. Refill the cooling system.
9. Clean the cooling system filler cap. Inspect the cooling system filler cap's gaskets. Replace the cooling system filler cap if the gaskets are damaged. Install the cooling system filler cap.
10. Start the engine. Inspect the cooling system for leaks.

i02857274

## Radiator - Clean

The following text describes a typical cleaning procedure for the radiator. For information on equipment that is not supplied by Perkins, refer to the OEM.

**Note:** Adjust the frequency of cleaning according to the effects of the operating environment.

Inspect the radiator for these items: damaged fins, corrosion, dirt, grease, insects, leaves, oil and other debris. Clean the radiator, if necessary.

### WARNING

**Personal injury can result from air pressure.**

**Personal injury can result without following proper procedure. When using pressure air, wear a protective face shield and protective clothing.**

**Maximum air pressure at the nozzle must be less than 205 kPa (30 psi) for cleaning purposes.**

Pressurized air is the preferred method for removing loose debris. Direct the air in the opposite direction of the fan's air flow. Hold the nozzle approximately 6 mm (0.25 inch) away from the fins. Slowly move the air nozzle in a direction that is parallel with the tubes. This will remove debris that is between the tubes.

Pressurized water may also be used for cleaning. The maximum water pressure for cleaning purposes must be less than 275 kPa (40 psi). Use pressurized water in order to soften mud. Clean the core from both sides.

Use a degreaser and steam for removal of oil and grease. Clean both sides of the core. Wash the core with detergent and hot water. Thoroughly rinse the core with clean water.

If the radiator is blocked internally, refer to the OEM for information regarding flushing the cooling system.

After cleaning the radiator, start the engine. This will help in the removal of debris and the drying of the core. Run the engine for two minutes and then stop the engine. Inspect the core for cleanliness. Repeat the cleaning, if necessary.

i02578376

## Severe Service Application - Check

Severe service is the application of an engine that exceeds the current published standards for that engine. Perkins maintains standards for the following engine parameters:

- Performance such as power range, speed range, and fuel consumption
- Fuel quality
- Operational Altitude
- Maintenance intervals
- Oil selection and maintenance
- Coolant type and maintenance
- Environmental qualities
- Installation
- The temperature of the fluid in the engine

Refer to the standards for the engine or consult your Perkins dealer or your Perkins distributor in order to determine if the engine is operating within the defined parameters.

Severe service operation can accelerate component wear. Engines that operate under severe conditions may need more frequent maintenance intervals in order to ensure maximum reliability and retention of full service life.

Due to individual applications, it is not possible to identify all of the factors which can contribute to severe service operation. Consult your Perkins dealer or your Perkins distributor for the unique maintenance that is necessary for the engine.

The operating environment, incorrect operating procedures and incorrect maintenance procedures can be factors which contribute to a severe service application.

## Environmental Factors

**Ambient temperatures** – The engine may be exposed to extended operation in extremely cold environments or hot environments. Valve components can be damaged by carbon buildup if the engine is frequently started and stopped in very cold temperatures. Extremely hot intake air reduces engine performance.

**Quality of the air** – The engine may be exposed to extended operation in an environment that is dirty or dusty, unless the equipment is cleaned regularly. Mud, dirt and dust can encase components. Maintenance can be very difficult. The buildup can contain corrosive chemicals.

**Buildup** – Compounds, elements, corrosive chemicals and salt can damage some components.

**Altitude** – Problems can arise when the engine is operated at altitudes that are higher than the intended settings for that application. Necessary adjustments should be made.

## Incorrect Operating Procedures

- Frequent hot shutdowns
- Operating at excessive loads
- Operating outside the intended application

## Incorrect Maintenance Procedures

- Extending the maintenance intervals

- Failure to use recommended fuel, lubricants and coolant or antifreeze

i02568202

## Starting Motor - Inspect

Perkins recommends a scheduled inspection of the starting motor. If the starting motor fails, the engine may not start in an emergency situation.

Check the starting motor for proper operation. Check the electrical connections and clean the electrical connections. Refer to the Service Manual for more information on the checking procedure and for specifications or consult your Perkins distributors for assistance.

i02568203

## Turbocharger - Inspect

Periodic inspection and cleaning is recommended for the turbocharger compressor housing (inlet side). Any fumes from the crankcase are filtered through the air inlet system. Therefore, by-products from oil and from combustion can collect in the turbocharger compressor housing. Over time, this buildup can contribute to loss of engine power, increased black smoke and overall loss of engine efficiency.

If the turbocharger fails during engine operation, damage to the turbocharger compressor wheel and/or to the engine may occur. Damage to the turbocharger compressor wheel can cause additional damage to the pistons, the valves, and the cylinder head.

---

### NOTICE

Turbocharger bearing failures can cause large quantities of oil to enter the air inlet and exhaust systems. Loss of engine lubricant can result in serious engine damage.

Minor leakage of a turbocharger housing under extended low idle operation should not cause problems as long as a turbocharger bearing failure has not occurred.

When a turbocharger bearing failure is accompanied by a significant engine performance loss (exhaust smoke or engine rpm up at no load), do not continue engine operation until the turbocharger is repaired or replaced.

---

An inspection of the turbocharger can minimize unscheduled downtime. An inspection of the turbocharger can also reduce the chance for potential damage to other engine parts.

**Note:** Turbocharger components require precision clearances. The turbocharger cartridge must be balanced due to high rpm. Severe Service Applications can accelerate component wear. Severe Service Applications require more frequent inspections of the cartridge.

## Removal and Installation

For options regarding the removal, installation, repair and replacement, consult your Perkins distributor. Refer to the Service Manual for this engine for the procedure and specifications.

## Cleaning and Inspecting

1. Remove the exhaust outlet piping and remove the air inlet piping from the turbocharger. Visually inspect the piping for the presence of oil. Clean the interior of the pipes in order to prevent dirt from entering during reassembly.
2. Turn the compressor wheel and the turbine wheel by hand. The assembly should turn freely. Inspect the compressor wheel and the turbine wheel for contact with the turbocharger housing. There should not be any visible signs of contact between the turbine wheel or compressor wheel and the turbocharger housing. If there is any indication of contact between the rotating turbine wheel or the compressor wheel and the turbocharger housing, the turbocharger must be reconditioned.
3. Check the compressor wheel for cleanliness. If only the blade side of the wheel is dirty, dirt and/or moisture is passing through the air filtering system. If oil is found only on the back side of the wheel, there is a possibility of a failed turbocharger oil seal.
 

The presence of oil may be the result of extended engine operation at low idle. The presence of oil may also be the result of a restriction of the line for the inlet air (plugged air filters), which causes the turbocharger to slobber.
4. Use a dial indicator to check the end clearance on the shaft. If the measured end play is greater than the Service Manual specifications, the turbocharger should be repaired or replaced. An end play measurement that is less than the minimum Service Manual specifications could indicate carbon buildup on the turbine wheel. The turbocharger should be disassembled for cleaning and for inspection if the measured end play is less than the minimum Service Manual specifications.
5. Inspect the bore of the turbine housing for corrosion.

6. Clean the turbocharger housing with standard shop solvents and a soft bristle brush.
7. Fasten the air inlet piping and the exhaust outlet piping to the turbocharger housing.

i02568213

## Walk-Around Inspection

### Inspect the Engine for Leaks and for Loose Connections

A walk-around inspection should only take a few minutes. When the time is taken to perform these checks, costly repairs and accidents can be avoided.

For maximum engine service life, make a thorough inspection of the engine compartment before starting the engine. Look for items such as oil leaks or coolant leaks, loose bolts, worn belts, loose connections and trash buildup. Make repairs, as needed:

- The guards must be in the proper place. Repair damaged guards or replace missing guards.
- Wipe all caps and plugs before the engine is serviced in order to reduce the chance of system contamination.

---

#### NOTICE

For any type of leak (coolant, lube, or fuel) clean up the fluid. If leaking is observed, find the source and correct the leak. If leaking is suspected, check the fluid levels more often than recommended until the leak is found or fixed, or until the suspicion of a leak is proved to be unwarranted.

---



---

#### NOTICE

Accumulated grease and/or oil on an engine or deck is a fire hazard. Remove this debris with steam cleaning or high pressure water.

---

- Ensure that the cooling lines are properly clamped and that the cooling lines are tight. Check for leaks. Check the condition of all pipes.
- Inspect the water pumps for coolant leaks.

**Note:** The water pump seal is lubricated by coolant in the cooling system. It is normal for a small amount of leakage to occur as the engine cools down and the parts contract.

Excessive coolant leakage may indicate the need to replace the water pump seal. For the removal of water pumps and the installation of water pumps and/or seals, refer to the Service Manual for the engine or consult your Perkins distributor.

- Inspect the lubrication system for leaks at the front crankshaft seal, the rear crankshaft seal, the oil pan, the oil filters and the valve cover.
- Inspect the fuel system for leaks. Look for loose fuel line clamps or for loose fuel line tie-wraps.
- Inspect the piping for the air inlet system and the elbows for cracks and for loose clamps. Ensure that hoses and tubes are not contacting other hoses, tubes, wiring harnesses, etc.
- Inspect the alternator belt and the accessory drive belts for cracks, breaks or other damage.

Belts for multiple groove pulleys must be replaced as matched sets. If only one belt is replaced, the belt will carry more load than the belts that are not replaced. The older belts are stretched. The additional load on the new belt could cause the belt to break.

- Drain the water and the sediment from fuel tanks on a daily basis in order to ensure that only clean fuel enters the fuel system.
- Inspect the wiring and the wiring harnesses for loose connections and for worn wires or frayed wires.
- Inspect the ground strap for a good connection and for good condition.
- Inspect the ECM to the cylinder head ground strap for a good connection and for good condition.
- Disconnect any battery chargers that are not protected against the current drain of the starting motor. Check the condition and the electrolyte level of the batteries, unless the engine is equipped with a maintenance free battery.
- Check the condition of the gauges. Replace any gauges that are cracked. Replace any gauge that can not be calibrated.

i02568235

## Water Pump - Inspect

A failed water pump might cause severe engine overheating problems that could result in the following conditions:

- Cracks in the cylinder head
- A piston seizure

- Other potential damage to the engine

Visually inspect the water pump for leaks. If any leaking is observed, replace the water pump seal or the water pump assembly. Refer to the Service Manual for the disassembly and assembly procedure.

**Note:** Refer to the Service Manual or consult your Perkins distributor if any repair is needed or any replacement is needed.

## Warranty Section

## Warranty Information

i06590874

### Emissions Warranty Information

This engine may be certified to comply with exhaust emission and gaseous emission standards that are prescribed by the law at the time of manufacture. This engine may be covered by an Emissions Warranty. Consult your authorized Perkins dealer or distributor to determine if your engine is emissions certified and if your engine is subject to an Emissions Warranty.

# Index

## A

|                                                                 |    |
|-----------------------------------------------------------------|----|
| After Starting Engine .....                                     | 36 |
| After Stopping Engine .....                                     | 38 |
| Aftercooler Core - Clean/Test (Air-To-Air<br>Aftercooler) ..... | 55 |
| Alternator - Inspect .....                                      | 55 |

## B

|                                             |        |
|---------------------------------------------|--------|
| Battery - Replace .....                     | 55     |
| Battery Electrolyte Level - Check .....     | 56     |
| Battery or Battery Cable - Disconnect ..... | 56     |
| Before Starting Engine .....                | 14, 35 |
| Belts - Inspect/Adjust/Replace .....        | 57     |
| Adjustment of the Fan Drive Belt .....      | 58     |
| Alternator Belt Adjustment .....            | 57     |
| Inspection .....                            | 57     |
| Replacement .....                           | 57     |
| Burn Prevention .....                       | 10     |
| Batteries .....                             | 11     |
| Coolant .....                               | 11     |
| Diesel Fuel .....                           | 11     |
| Oils .....                                  | 11     |
| Viton Seals .....                           | 11     |

## C

|                                                               |    |
|---------------------------------------------------------------|----|
| Cold Weather Operation .....                                  | 39 |
| Hints for Cold Weather Operation .....                        | 39 |
| Recommendations for the Coolant .....                         | 39 |
| Viscosity of the Engine Lubrication Oil .....                 | 39 |
| Cold Weather Starting .....                                   | 35 |
| Cooling System Coolant (ELC) - Change .....                   | 58 |
| Drain .....                                                   | 58 |
| Fill .....                                                    | 59 |
| Flush .....                                                   | 59 |
| Cooling System Coolant Level - Check .....                    | 59 |
| Cooling System Water Temperature<br>Regulator - Replace ..... | 60 |
| Crankshaft Vibration Damper - Inspect .....                   | 60 |
| Visconic Damper .....                                         | 61 |
| Crushing Prevention and Cutting Prevention ..                 | 13 |
| Customer Specified Parameters .....                           | 24 |
| Programmable Monitoring System (PMS) ..                       | 24 |

## D

|                                |    |
|--------------------------------|----|
| Diagnostic Lamp .....          | 33 |
| Driven Equipment - Check ..... | 61 |

## E

|                                                                        |        |
|------------------------------------------------------------------------|--------|
| Electrical System .....                                                | 15     |
| Grounding Practices .....                                              | 15     |
| Electronic Unit Injector - Inspect/Adjust .....                        | 61     |
| Emissions Certification Film .....                                     | 23     |
| Label for compliant engines .....                                      | 23     |
| Emissions Warranty Information .....                                   | 78     |
| Engine - Clean .....                                                   | 62     |
| Engine Air Cleaner Element (Single<br>Element) - Inspect/Replace ..... | 62     |
| Cleaning the Air Cleaner Element .....                                 | 62     |
| Servicing the Air Cleaner Element .....                                | 62     |
| Engine Air Cleaner Service Indicator -<br>Inspect (If Equipped) .....  | 63     |
| Engine Crankcase Breather - Replace .....                              | 64     |
| Engine Description .....                                               | 19     |
| Aftermarket Products and Perkins<br>Engines .....                      | 20     |
| Engine Diagnostics .....                                               | 33     |
| Engine Electronics .....                                               | 16     |
| Engine Mounts - Inspect .....                                          | 65     |
| Engine Oil and Filter - Change .....                                   | 66     |
| Drain the Engine Oil .....                                             | 66     |
| Fill the Engine Crankcase .....                                        | 67     |
| Replace the Oil Filter .....                                           | 67     |
| Engine Oil Level - Check .....                                         | 65     |
| Engine Oil Sample - Obtain .....                                       | 65     |
| Obtain the Sample and the Analysis .....                               | 66     |
| Engine Operation .....                                                 | 37     |
| Engine Operation with Active Diagnostic<br>Codes .....                 | 33     |
| Engine Operation with Intermittent<br>Diagnostic Codes .....           | 33     |
| Engine Protective Devices - Check .....                                | 68     |
| Calibration Check .....                                                | 68     |
| Visual Inspection .....                                                | 68     |
| Engine Speed/Timing Sensors - Check/<br>Clean/Calibrate .....          | 68     |
| Engine Starting .....                                                  | 14, 35 |
| Engine Stopping .....                                                  | 14, 38 |
| Engine Valve Lash - Inspect/Adjust .....                               | 69     |

## F

|                                                |    |
|------------------------------------------------|----|
| Fault Logging .....                            | 33 |
| Features and Controls .....                    | 28 |
| Fire Prevention and Explosion Prevention ..... | 11 |
| Fire Extinguisher .....                        | 13 |

|                                              |    |                                           |    |
|----------------------------------------------|----|-------------------------------------------|----|
| Lines, Tubes, and Hoses .....                | 13 | <b>L</b>                                  |    |
| Fluid Recommendations .....                  | 42 | Lifting and Storage .....                 | 26 |
| Cooling System Specifications .....          | 48 |                                           |    |
| ELC Cooling System Maintenance.....          | 51 | <b>M</b>                                  |    |
| Engine Oil .....                             | 43 | Maintenance Interval Schedule.....        | 54 |
| Fuel Specifications .....                    | 46 | Daily .....                               | 54 |
| General Lubricant Information.....           | 42 | Every 1000 Service Hours.....             | 54 |
| Foreword .....                               | 4  | Every 1000 Service Hours or 1 Year .....  | 54 |
| California Proposition 65 Warning.....       | 4  | Every 2000 Service Hours.....             | 54 |
| Literature Information .....                 | 4  | Every 250 Service Hours or 1 Year .....   | 54 |
| Maintenance .....                            | 4  | Every 3000 Service Hours or 2 Years ..... | 54 |
| Maintenance Intervals .....                  | 5  | Every 500 Service Hours.....              | 54 |
| Operation .....                              | 4  | Every 500 Service Hours or 1 Year .....   | 54 |
| Overhaul .....                               | 5  | Every 5000 Service Hours.....             | 54 |
| Safety.....                                  | 4  | Every 6000 Service Hours or 3 Years ..... | 54 |
| Fuel and the Effect from Cold Weather .....  | 39 | Initial 500 Service Hours.....            | 54 |
| Fuel Conservation Practices .....            | 37 | When Required.....                        | 54 |
| Fuel Related Components in Cold Weather ...  | 40 | Maintenance Section.....                  | 42 |
| Fuel Filters .....                           | 40 | Manual Stop Procedure .....               | 38 |
| Fuel Tanks .....                             | 40 | Emergency Stopping .....                  | 38 |
| Fuel System - Prime .....                    | 69 | Stopping the Engine .....                 | 38 |
| Fuel System Primary Filter (Water            |    | Model View Illustrations .....            | 18 |
| Separator) Element - Replace.....            | 70 | Model Views .....                         | 18 |
| Fuel System Primary Filter/Water             |    | Monitoring System.....                    | 28 |
| Separator - Drain.....                       | 70 | Action Alert .....                        | 28 |
| Fuel System Secondary Filter - Replace ..... | 71 | Altitude derate.....                      | 29 |
| Fuel Tank Water and Sediment - Drain .....   | 72 | Critical Protection Override.....         | 28 |
| Drain the Water and the Sediment .....       | 72 | Diagnostic .....                          | 29 |
| Fuel Storage Tanks.....                      | 72 | Shutdown.....                             | 28 |
| Fuel Tank .....                              | 72 | Shutdown Reset .....                      | 29 |
|                                              |    | Standard Warning Outputs .....            | 29 |
| <b>G</b>                                     |    | Warning Alarm .....                       | 28 |
| Gauges and Indicators .....                  | 27 | Mounting and Dismounting .....            | 13 |
| General Hazard Information.....              | 7  |                                           |    |
| Containing Fluid Spillage.....               | 8  | <b>O</b>                                  |    |
| Fluid Penetration .....                      | 8  | Operation Section.....                    | 26 |
| Inhalation .....                             | 9  |                                           |    |
| Pressure Air and Water .....                 | 8  | <b>P</b>                                  |    |
| Static Electricity Hazard when Fueling with  |    | Plate Locations and Film Locations .....  | 21 |
| Ultra-low Sulfur Diesel Fuel .....           | 9  | Serial Number Plate (1).....              | 21 |
| General Information .....                    | 17 | Product Identification Information .....  | 21 |
|                                              |    | Product Information Section.....          | 17 |
| <b>H</b>                                     |    | Product Lifting .....                     | 26 |
| Hoses and Clamps - Inspect/Replace.....      | 72 | Product Storage .....                     | 26 |
| Replace the Hoses and the Clamps .....       | 73 | Level "A " .....                          | 26 |
|                                              |    | Level "B " .....                          | 26 |
| <b>I</b>                                     |    | Level "C " .....                          | 26 |
| Important Safety Information.....            | 2  |                                           |    |



**R**

|                            |    |
|----------------------------|----|
| Radiator - Clean .....     | 73 |
| Reference Numbers .....    | 22 |
| Record for Reference ..... | 22 |
| Refill Capacities .....    | 42 |
| Cooling System.....        | 42 |
| Lubrication System .....   | 42 |

**S**

|                                           |    |
|-------------------------------------------|----|
| Safety Messages.....                      | 6  |
| (1) Universal Warning .....               | 6  |
| Safety Section .....                      | 6  |
| Self-Diagnostics .....                    | 33 |
| Sensors and Electrical Components.....    | 30 |
| Crankshaft Position Sensor 9 .....        | 32 |
| Engine Coolant Temperature Sensor 1 ..... | 31 |
| Engine Oil Pressure Sensor 7 .....        | 31 |
| Failure of Sensors.....                   | 31 |
| Inlet Manifold Pressure Sensor 3 .....    | 31 |
| Inlet Manifold Temperature Sensor 5 ..... | 31 |
| Programmable Monitoring System (PMS)...   | 31 |
| Sensor Locations .....                    | 30 |
| Severe Service Application - Check.....   | 74 |
| Environmental Factors.....                | 74 |
| Incorrect Maintenance Procedures .....    | 74 |
| Incorrect Operating Procedures .....      | 74 |
| Starting Motor - Inspect.....             | 75 |
| Starting the Engine .....                 | 35 |
| New engines .....                         | 35 |
| Starting the Engine .....                 | 35 |
| Starting with Jump Start Cables .....     | 36 |

**T**

|                                |    |
|--------------------------------|----|
| Table of Contents .....        | 3  |
| Turbocharger - Inspect.....    | 75 |
| Cleaning and Inspecting .....  | 75 |
| Removal and Installation ..... | 75 |

**W**

|                                                                 |    |
|-----------------------------------------------------------------|----|
| Walk-Around Inspection .....                                    | 76 |
| Inspect the Engine for Leaks and for Loose<br>Connections ..... | 76 |
| Warranty Information.....                                       | 78 |
| Warranty Section .....                                          | 78 |
| Water Pump - Inspect.....                                       | 76 |
| Welding on Engines with Electronic<br>Controls .....            | 17 |



# Product and Dealer Information

Note: For product identification plate locations, see the section "Product Identification Information" in the Operation and Maintenance Manual.

Delivery Date: \_\_\_\_\_

## Product Information

Model: \_\_\_\_\_

Product Identification Number: \_\_\_\_\_

Engine Serial Number: \_\_\_\_\_

Transmission Serial Number: \_\_\_\_\_

Generator Serial Number: \_\_\_\_\_

Attachment Serial Numbers: \_\_\_\_\_

Attachment Information: \_\_\_\_\_

Customer Equipment Number: \_\_\_\_\_

Dealer Equipment Number: \_\_\_\_\_

## Dealer Information

Name: \_\_\_\_\_ Branch: \_\_\_\_\_

Address: \_\_\_\_\_

\_\_\_\_\_

\_\_\_\_\_

Dealer Contact

Phone Number

Hours

Sales: \_\_\_\_\_

Parts: \_\_\_\_\_

Service: \_\_\_\_\_

SEBU8313  
©2021 Perkins Engines Company Limited  
All Rights Reserved