



SEBU8603-05 (en-us)
January 2023

THE HEART OF EVERY GREAT MACHINE

Operation and Maintenance Manual

1206E-E66TA Industrial Engine

Important Safety Information

Most accidents that involve product operation, maintenance and repair are caused by failure to observe basic safety rules or precautions. An accident can often be avoided by recognizing potentially hazardous situations before an accident occurs. A person must be alert to potential hazards. This person should also have the necessary training, skills and tools to perform these functions correctly.

Incorrect operation, lubrication, maintenance or repair of this product can be dangerous and could result in injury or death.

Do not operate or perform any lubrication, maintenance or repair on this product, until you have read and understood the operation, lubrication, maintenance and repair information.

Safety precautions and warnings are provided in this manual and on the product. If these hazard warnings are not heeded, bodily injury or death could occur to you or to other persons.

The hazards are identified by the "Safety Alert Symbol" and followed by a "Signal Word" such as "DANGER", "WARNING" or "CAUTION". The Safety Alert "WARNING" label is shown below.



The meaning of this safety alert symbol is as follows:

Attention! Become Alert! Your Safety is Involved.

The message that appears under the warning explains the hazard and can be either written or pictorially presented.

Operations that may cause product damage are identified by "NOTICE" labels on the product and in this publication.

Perkins cannot anticipate every possible circumstance that might involve a potential hazard. The warnings in this publication and on the product are, therefore, not all inclusive. You must not use this product in any manner different from that considered by this manual without first satisfying yourself that you have considered all safety rules and precautions applicable to the operation of the product in the location of use, including site-specific rules and precautions applicable to the worksite. If a tool, procedure, work method or operating technique that is not specifically recommended by Perkins is used, you must satisfy yourself that it is safe for you and for others. You should also ensure that you are authorized to perform this work, and that the product will not be damaged or become unsafe by the operation, lubrication, maintenance or repair procedures that you intend to use.

The information, specifications, and illustrations in this publication are on the basis of information that was available at the time that the publication was written. The specifications, torques, pressures, measurements, adjustments, illustrations, and other items can change at any time. These changes can affect the service that is given to the product. Obtain the complete and most current information before you start any job. Perkins dealers or Perkins distributors have the most current information available.



When replacement parts are required for this product Perkins recommends using Perkins replacement parts.

Failure to heed this warning can lead to premature failures, product damage, personal injury or death.

In the United States, the maintenance, replacement, or repair of the emission control devices and systems may be performed by any repair establishment or individual of the owner's choosing.

Table of Contents

Foreword	4	Cold Weather Operation	59
Safety Section		Maintenance Section	
Safety Messages	6	Refill Capacities.....	63
General Hazard Information.....	9	Maintenance Recommendations	79
Burn Prevention.....	12	Maintenance Interval Schedule.....	81
Fire Prevention and Explosion Prevention.....	13	Warranty Section	
Crushing Prevention and Cutting Prevention..	15	Warranty Information.....	115
Mounting and Dismounting	16	Reference Information Section	
High Pressure Fuel Lines	16	Reference Materials	119
Before Starting Engine	17	Index Section	
Engine Starting.....	18	Index.....	120
Engine Stopping	18		
Electrical System.....	18		
Engine Electronics.....	20		
Product Information Section			
Model Views	21		
Product Identification Information	28		
Operation Section			
Lifting and Storage	30		
Gauges and Indicators	33		
Features and Controls.....	35		
Engine Diagnostics	45		
Engine Starting.....	51		
Engine Operation	55		
Engine Stopping	57		

Foreword

California Proposition 65 Warning

Diesel engine exhaust and some of its constituents are known to the State of California to cause cancer, birth defects, and other reproductive harm.



WARNING – This product can expose you to chemicals including ethylene glycol, which is known to the State of California to cause birth defects or other reproductive harm. For more information go to:

www.P65Warnings.ca.gov

Do not ingest this chemical. Wash hands after handling to avoid incidental ingestion.



WARNING – This product can expose you to chemicals including lead and lead compounds, which are known to the State of California to cause cancer, birth defects, or other reproductive harm. For more information go to:

www.P65Warnings.ca.gov

Wash hands after handling components that may contain lead.

Literature Information

This manual contains safety, operation instructions, lubrication, and maintenance information. This manual should be stored in or near the engine area in a literature holder or literature storage area. Read, study, and keep the manual with the literature and engine information.

English is the primary language for all Perkins publications. The English used facilitates translation and consistency.

Some photographs or illustrations in this manual show details or attachments that may be different from your engine. Guards and covers may have been removed for illustrative purposes. Continuing improvement and advancement of product design may have caused changes to your engine which are not included in this manual. Whenever a question arises regarding your engine, or this manual, please consult with your Perkins dealer or your Perkins distributor for the latest available information.

Safety

This safety section lists basic safety precautions. In addition, this section identifies hazardous, warning situations. Read and understand the basic precautions listed in the safety section before operating or performing lubrication, maintenance, and repair on this product.

Operation

Operating techniques outlined in this manual are basic. The operating techniques assist with developing the skills and techniques required to operate the engine more efficiently and economically. Skill and techniques develop as the operator gains knowledge of the engine and the capabilities of the engine.

The operation section is a reference for operators. Photographs and illustrations guide the operator through procedures of inspecting, starting, operating, and stopping the engine. This section also includes a discussion of electronic diagnostic information.

Maintenance

The maintenance section is a guide to engine care. The illustrated, step-by-step instructions are grouped by service hours and/or calendar time maintenance intervals. Items in the maintenance schedule are referenced to detailed instructions that follow.

Recommended service should be performed at the appropriate intervals as indicated in the Maintenance Interval Schedule. The actual operating environment of the engine also governs the Maintenance Interval Schedule. Therefore, under severe, dusty, wet, or freezing cold operating conditions, more frequent lubrication, and maintenance than is specified in the Maintenance Interval Schedule may be necessary.

The maintenance schedule items are organized for a preventive maintenance management program. If the preventive maintenance program is followed, a periodic tune-up is not required. The implementation of a preventive maintenance management program should minimize operating costs through cost avoidances resulting from reductions in unscheduled downtime and failures.

Maintenance Intervals

Perform maintenance on items at multiples of the original requirement. Each level and/or individual items in each level should be shifted ahead or back depending upon your specific maintenance practices, operation, and application. Perkins recommends that the maintenance schedules be reproduced and displayed near the engine as a convenient reminder. Perkins also recommends that a maintenance record be maintained as part of the permanent record of the engine.

Your authorized Perkins dealer or your Perkins distributor can assist you in adjusting your maintenance schedule to meet the needs of your operating environment.

Overhaul

Major engine overhaul details are not covered in the Operation and Maintenance Manual except for the interval and the maintenance items in that interval. Major repairs are best left to trained personnel or an authorized Perkins distributor or dealer. Your Perkins dealer or your Perkins distributor offers various options regarding overhaul programs. If you experience a major engine failure, there are also numerous after failure overhaul options available. Consult with your Perkins dealer or your Perkins distributor for information regarding these options.

Safety Section

i04220089

Safety Messages

There may be several specific warning signs on your engine. The exact location and a description of the warning signs are reviewed in this section. Please become familiar with all warning signs.

Ensure that all of the warning signs are legible. Clean the warning signs or replace the warning signs if the words cannot be read or if the illustrations are not visible. Use a cloth, water, and soap to clean the warning signs. Do not use solvents, gasoline, or other harsh chemicals. Solvents, gasoline, or harsh chemicals could loosen the adhesive that secures the warning signs. The warning signs that are loosened could drop off the engine.

Replace any warning sign that is damaged or missing. If a warning sign is attached to a part of the engine that is replaced, install a new warning sign on the replacement part. Your Perkins distributor can provide new warning signs.

(1) Universal Warning



Do not operate or work on this equipment unless you have read and understand the instructions and warnings in the Operation and Maintenance Manuals. Failure to follow the instructions or heed the warnings could result in serious injury or death.

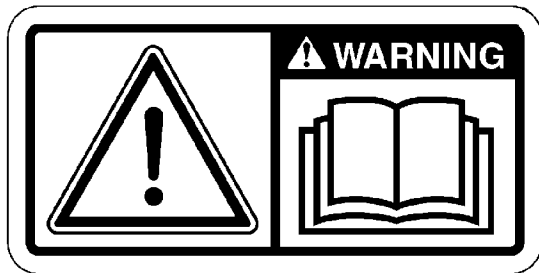

Illustration 1

g01154807

Typical example

The Universal Warning label (1) is located in two positions. The warning labels are located on the front right side of the valve mechanism cover and located on the side of the NOx reduction system (NRS).

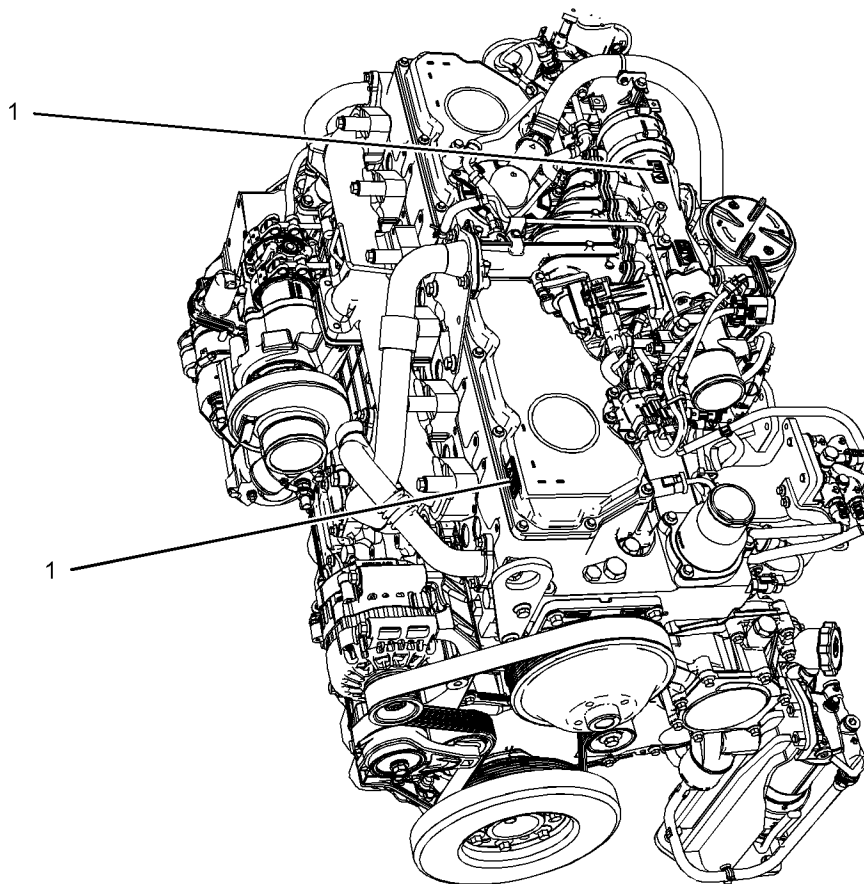

Illustration 2

g02382617

Typical example

(1) Universal warning

(2) Hand (High Pressure)**⚠ WARNING**

Contact with high pressure fuel may cause fluid penetration and burn hazards. High pressure fuel spray may cause a fire hazard. Failure to follow these inspection, maintenance and service instructions may cause personal injury or death.



Illustration 3

g02382677

Typical example

The warning label for the Hand (High Pressure) (3) is a wrap around label that is installed on the high-pressure fuel line.

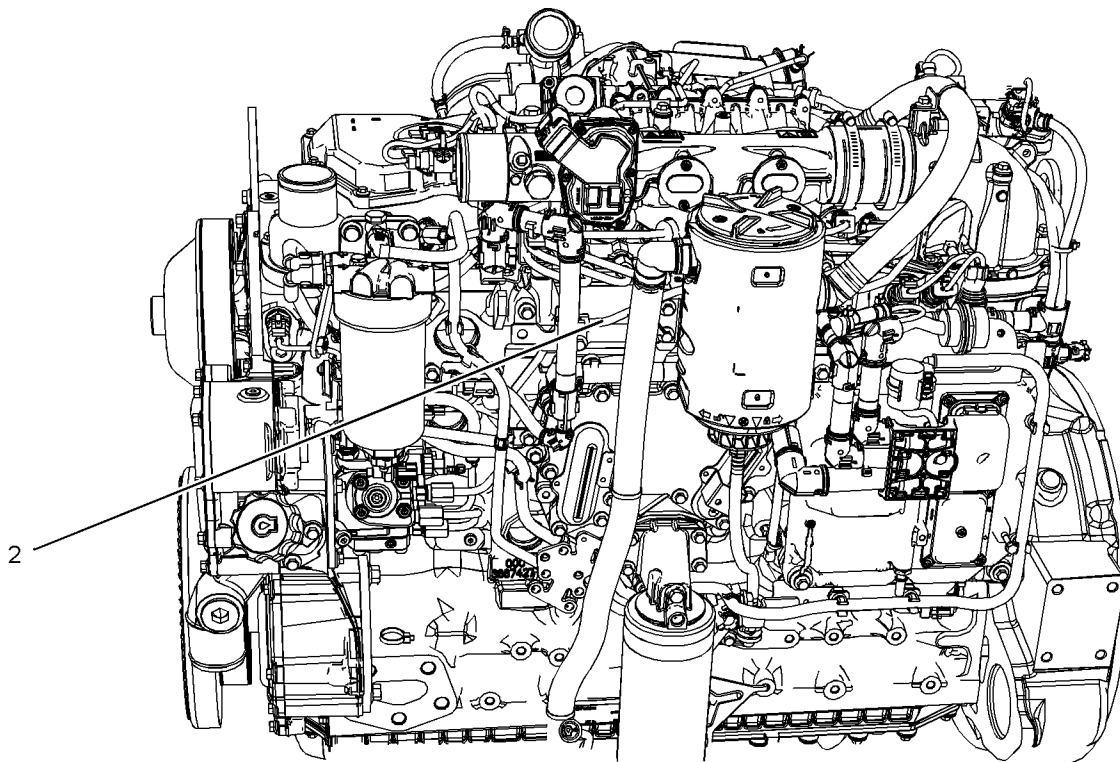

Illustration 4

g02382618

Typical example

Ether Warning

WARNING

Do not use aerosol types of starting aids such as ether. Such use could result in an explosion and personal injury.



Illustration 5

g01154809

Typical example

An ether warning label will be installed on the air cleaner or close to the air cleaner. The location will depend on the application.

i08315538

General Hazard Information

Illustration 6

g00104545

Attach a "Do Not Operate" warning tag or a similar warning tag to the start switch or to the controls before the engine is serviced or before the engine is repaired. Attach the warning tags to the engine and to each operator control station. When appropriate, disconnect the starting controls.

Do not allow unauthorized personnel on the engine, or around the engine when the engine is being serviced.

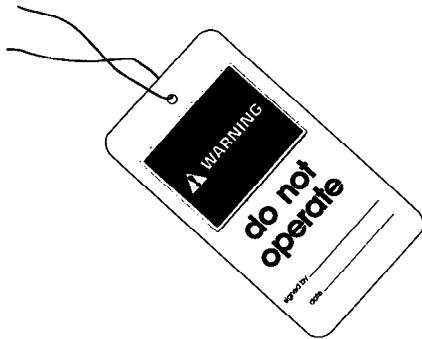
- Tampering with the engine installation or tampering with the OEM supplied wiring can be dangerous. Personal injury, death and/or engine damage could result.
- Vent the engine exhaust to the outside when the engine is operated in an enclosed area.

- If the engine is not running, do not release the secondary brake or the parking brake systems unless the vehicle is blocked or unless the vehicle is restrained.
- Wear a hard hat, protective glasses, and other protective equipment, as required.
- When work is performed around an engine that is operating, wear protective devices for ears to help prevent damage to hearing.
- Do not wear loose clothing or jewelry that can snag on controls or on other parts of the engine.
- Ensure that all protective guards and all covers are secured in place on the engine.
- Never put maintenance fluids into glass containers. Glass containers can break.
- Use all cleaning solutions with care.
- Report all necessary repairs.

Unless other instructions are provided, perform the maintenance under the following conditions:

- The engine is stopped. Ensure that the engine cannot be started.
- The protective locks or the controls are in the applied position.
- Engage the secondary brakes or parking brakes.
- Block the vehicle or restrain the vehicle before maintenance or repairs are performed.
- Disconnect the batteries when maintenance is performed or when the electrical system is serviced. Disconnect the battery ground leads. Tape the leads to help prevent sparks.
- Disconnect the connector for the unit injector that is on the valve cover base. This action will help prevent personal injury from the high voltage to the unit injectors. Do not come in contact with the unit injector terminals while the engine is operating.
- Do not attempt any repairs or any adjustments to the engine while the engine is operating.
- Do not attempt any repairs that are not understood. Use the proper tools. Replace any equipment that is damaged or repair the equipment.

Safety Section

General Hazard Information

- For initial start-up of a new engine or for starting an engine that has been serviced, make provisions to stop the engine if an overspeed occurs. This action may be accomplished by shutting off the fuel supply and/or the air supply to the engine.
- Start the engine from the operators station (cab). Never short across the starting motor terminals or the batteries. This action could bypass the engine neutral start system and/or the electrical system could be damaged.

Engine exhaust contains products of combustion which may be harmful to your health. Always start the engine and operate the engine in a well ventilated area. If the engine is in an enclosed area, vent the engine exhaust to the outside.

Cautiously remove the following parts. To help prevent spraying or splashing of pressurized fluids, hold a rag over the part that is being removed.

- Filler caps
- Grease fittings
- Pressure taps
- Breathers
- Drain plugs

Use caution when cover plates are removed. Gradually loosen, but do not remove the last two bolts or nuts that are at opposite ends of the cover plate or the device. Before removing the last two bolts or nuts, pry the cover loose to relieve any spring pressure or other pressure.

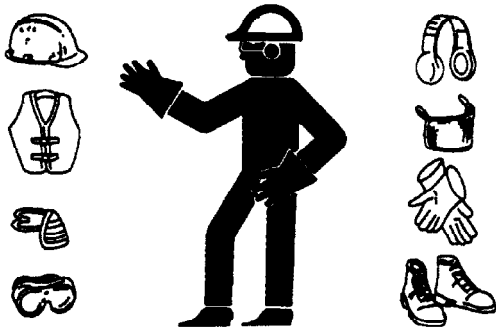

Illustration 7

g00702020

- Wear a hard hat, protective glasses, and other protective equipment, as required.
- When work is performed around an engine that is operating, wear protective devices for ears to help prevent damage to hearing.

- Do not wear loose clothing or jewelry that can snag on controls or on other parts of the engine.
- Ensure that all protective guards and all covers are secured in place on the engine.
- Never put maintenance fluids into glass containers. Glass containers can break.
- Use all cleaning solutions with care.
- Report all necessary repairs.

Unless other instructions are provided, perform the maintenance under the following conditions:

- The engine is stopped. Ensure that the engine cannot be started.
- Disconnect the batteries when maintenance is performed or when the electrical system is serviced. Disconnect the battery ground leads. Tape the leads to help prevent sparks.
- Do not attempt any repairs that are not understood. Use the proper tools. Replace any equipment that is damaged or repair the equipment.

Pressurized Air and Water

Pressurized air and/or water can cause debris and/or hot water to be blown out and could result in personal injury.

When pressurized air and/or pressurized water is used for cleaning, wear protective clothing, protective shoes, and eye protection. Eye protection includes goggles or a protective face shield.

The maximum air pressure for cleaning purposes must be below 205 kPa (30 psi). The maximum water pressure for cleaning purposes must be below 275 kPa (40 psi).

Fluid Penetration

Pressure can be trapped in the hydraulic circuit long after the engine has been stopped. The pressure can cause hydraulic fluid or items such as pipe plugs to escape rapidly if the pressure is not relieved correctly.

Do not remove any hydraulic components or parts until pressure has been relieved or personal injury may occur. Do not disassemble any hydraulic components or parts until pressure has been relieved or personal injury may occur. Refer to the OEM information for any procedures that are required to relieve the hydraulic pressure.

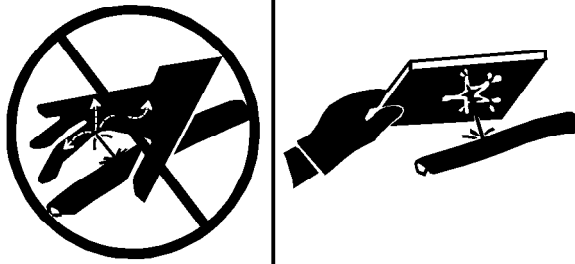

Illustration 8

g00687600

Always use a board or cardboard when you check for a leak. Leaking fluid that is under pressure can penetrate body tissue. Fluid penetration can cause serious injury and possible death. A pin hole leak can cause severe injury. If fluid is injected into your skin, you must get treatment immediately. Seek treatment from a doctor that is familiar with this type of injury.

Containing Fluid Spillage

NOTICE

Care must be taken to ensure that fluids are contained during performance of inspection, maintenance, testing, adjusting, and repair of the product. Be prepared to collect the fluid with suitable containers before opening any compartment or disassembling any component containing fluids.

Dispose of all fluids according to local regulations and mandates.

Static Electricity Hazard when Fueling with Ultra-low Sulfur Diesel Fuel

The removal of sulfur and other compounds in ultra-low sulfur diesel fuel (ULSD fuel) decreases the conductivity of ULSD and increases the ability of ULSD to store static charge. Refineries may have treated the fuel with a static dissipating additive. Many factors can reduce the effectiveness of the additive over time. Static charges can build up in ULSD fuel while the fuel is flowing through fuel delivery systems. Static electricity discharge when combustible vapors are present could result in a fire or explosion. Ensure that the entire system used to refuel your machine (fuel supply tank, transfer pump, transfer hose, nozzle, and others) is properly grounded and bonded. Consult with your fuel or fuel system supplier to ensure that the delivery system complies with fueling standards for proper grounding and bonding.

WARNING

Avoid static electricity risk when fueling. Ultra-low sulfur diesel fuel (ULSD fuel) poses a greater static ignition hazard than earlier diesel formulations with a higher sulfur contents. Avoid death or serious injury from fire or explosion. Consult with your fuel or fuel system supplier to ensure the delivery system is in compliance with fueling standards for proper grounding and bonding practices.

Inhalation

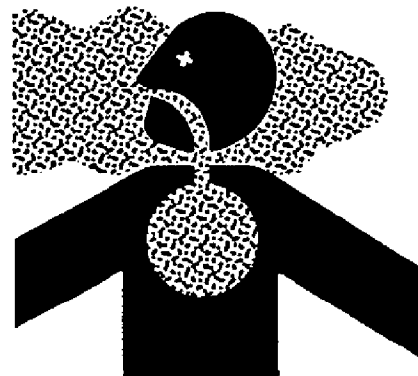

Illustration 9

g00702022

Exhaust

Use caution. Exhaust fumes can be hazardous to health. If you operate the equipment in an enclosed area, adequate ventilation is necessary.

Hexavalent Chromium

Perkins equipment and replacement parts comply with applicable regulations and requirements where originally sold. Perkins recommends the use of only genuine Perkins replacement parts.

Hexavalent chromium has occasionally been detected on exhaust and heat shield systems on Perkins engines. Although laboratory testing is the only accurate way to know if hexavalent chromium is, in fact, present, the presence of a yellow deposit in areas of high heat (for example, exhaust system components or exhaust insulation) may be an indication of the presence of hexavalent chromium.

Use caution if you suspect the presence of hexavalent chromium. Avoid skin contact when handling items that you suspect may contain hexavalent chromium, and avoid inhalation of any dust in the suspect area. Inhalation of, or skin contact with, hexavalent chromium dust may be hazardous to your health.

Safety Section

Burn Prevention

If such yellow deposits are found on the engine, engine component parts, or associated equipment or packages, Perkins recommends following local health and safety regulations and guidelines, utilizing good hygiene, and adhering to safe work practices when handling the equipment or parts. Perkins also recommends the following:

- Wear appropriate Personal Protective Equipment (PPE)
- Wash your hands and face with soap and water prior to eating, drinking, or smoking, and also during rest room breaks, to prevent ingestion of any yellow powder
- Never use compressed air for cleaning areas suspected of containing hexavalent chromium
- Avoid brushing, grinding, or cutting materials suspected of containing hexavalent chromium
- Obey environmental regulations for the disposal of all materials that may contain or have come into contact with hexavalent chromium
- Stay away from areas that might have hexavalent chromium particles in the air.

Asbestos Information

Perkins equipment and replacement parts that are shipped from Perkins engine company limited are asbestos free. Perkins recommends the use of only genuine Perkins replacement parts. Use the following guidelines when you handle any replacement parts that contain asbestos or when you handle asbestos debris.

Use caution. Avoid inhaling dust that might be generated when you handle components that contain asbestos fibers. Inhaling this dust can be hazardous to your health. The components that may contain asbestos fibers are brake pads, brake bands, lining material, clutch plates, and some gaskets. The asbestos that is used in these components is usually bound in a resin or sealed in some way. Normal handling is not hazardous unless airborne dust that contains asbestos is generated.

If dust that may contain asbestos is present, there are several guidelines that should be followed:

- Never use compressed air for cleaning.
- Avoid brushing materials that contain asbestos.
- Avoid grinding materials that contain asbestos.
- Use a wet method to clean up asbestos materials.
- A vacuum cleaner that is equipped with a high efficiency particulate air filter (HEPA) can also be used.

- Use exhaust ventilation on permanent machining jobs.
- Wear an approved respirator if there is no other way to control the dust.
- Comply with applicable rules and regulations for the work place. In the United States, use Occupational Safety and Health Administration (OSHA) requirements. These OSHA requirements can be found in "29 CFR 1910.1001".
- Obey environmental regulations for the disposal of asbestos.
- Stay away from areas that might have asbestos particles in the air.

Dispose of Waste Properly

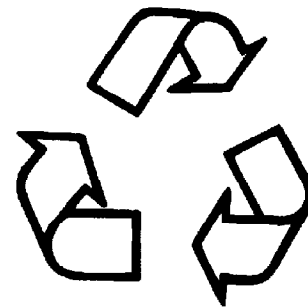

Illustration 10

g00706404

Improperly disposing of waste can threaten the environment. Potentially harmful fluids should be disposed of according to local regulations.

Always use leakproof containers when you drain fluids. Do not pour waste onto the ground, down a drain, or into any source of water.

i04224009

Burn Prevention

Do not touch any part of an operating engine system. The engine, the exhaust, and the engine aftertreatment system surface temperatures can reach temperatures of approximately 600° C (1112 ° F) under normal operating conditions.

Allow the engine system to cool before any maintenance is performed.

Relieve all pressure in the following systems, hydraulic system, lubrication system, fuel system, and the coolant system before the related items are disconnected.

WARNING

Contact with high pressure fuel may cause fluid penetration and burn hazards. High pressure fuel spray may cause a fire hazard. Failure to follow these inspection, maintenance and service instructions may cause personal injury or death.

After the engine has stopped, you must wait for 10 minutes in order to allow the fuel pressure to be purged from the high-pressure fuel lines before any service or repair is performed on the engine fuel lines.

Allow the pressure to be purged in the air system, in the hydraulic system, in the lubrication system, or in the cooling system before any lines, fittings, or related items are disconnected.

Induction System

WARNING

Sulfuric Acid Burn Hazard may cause serious personal injury or death.

The exhaust gas cooler may contain a small amount of sulfuric acid. The use of fuel with sulfur levels greater than 15 ppm may increase the amount of sulfuric acid formed. The sulfuric acid may spill from the cooler during service of the engine. The sulfuric acid will burn the eyes, skin and clothing on contact. Always wear the appropriate personal protective equipment (PPE) that is noted on a material safety data sheet (MSDS) for sulfuric acid. Always follow the directions for first aid that are noted on a material safety data sheet (MSDS) for sulfuric acid.

Coolant

When the engine is at operating temperature, the engine coolant is hot. The coolant is also under pressure. The radiator and all lines to the heaters or to the engine contain hot coolant.

Any contact with hot coolant or with steam can cause severe burns. Allow cooling system components to cool before the cooling system is drained.

Check that the coolant level after the engine has stopped and the engine has been allowed to cool.

Ensure that the filler cap is cool before removing the filler cap. The filler cap must be cool enough to touch with a bare hand. Remove the filler cap slowly in order to relieve pressure.

Cooling system conditioner contains alkali. Alkali can cause personal injury. Do not allow alkali to contact the skin, the eyes, or the mouth.

Oils

Hot oil and hot lubricating components can cause personal injury. Do not allow hot oil to contact the skin. Also, do not allow hot components to contact the skin.

Batteries

Electrolyte is an acid. Electrolyte can cause personal injury. Do not allow electrolyte to contact the skin or the eyes. Always wear protective glasses for servicing batteries. Wash hands after touching the batteries and connectors. Use of gloves is recommended.

i07817010

Fire Prevention and Explosion Prevention



Illustration 11

g00704000

All fuels, most lubricants, and some coolant mixtures are flammable.

Flammable fluids that are leaking or spilled onto hot surfaces or onto electrical components can cause a fire. Fire may cause personal injury and property damage.

After the emergency stop button is operated, ensure that you allow 15 minutes, before the engine covers are removed.

Determine whether the engine will be operated in an environment that allows combustible gases to be drawn into the air inlet system. These gases could cause the engine to overspeed. Personal injury, property damage, or engine damage could result.

Safety Section
Fire Prevention and Explosion Prevention

If the application involves the presence of combustible gases, consult your Perkins dealer and/or your Perkins distributor for additional information about suitable protection devices.

Remove all flammable combustible materials or conductive materials such as fuel, oil, and debris from the engine. Do not allow any flammable combustible materials or conductive materials to accumulate on the engine.

Store fuels and lubricants in correctly marked containers away from unauthorized persons. Store oily rags and any flammable materials in protective containers. Do not smoke in areas that are used for storing flammable materials.

Do not expose the engine to any flame.

Exhaust shields (if equipped) protect hot exhaust components from oil or fuel spray if there was a line, a tube, or a seal failure. Exhaust shields must be installed correctly.

Do not weld on lines or tanks that contain flammable fluids. Do not flame cut lines or tanks that contain flammable fluid. Clean any such lines or tanks thoroughly with a nonflammable solvent prior to welding or flame cutting.

Wiring must be kept in good condition. Ensure that all electrical wires are correctly installed and securely attached. Check all electrical wires daily. Repair any wires that are loose or frayed before you operate the engine. Clean all electrical connections and tighten all electrical connections.

Eliminate all wiring that is unattached or unnecessary. Do not use any wires or cables that are smaller than the recommended gauge. Do not bypass any fuses and/or circuit breakers.

Arcing or sparking could cause a fire. Secure connections, recommended wiring, and correctly maintained battery cables will help to prevent arcing or sparking.

⚠ WARNING

Contact with high pressure fuel may cause fluid penetration and burn hazards. High pressure fuel spray may cause a fire hazard. Failure to follow these inspection, maintenance and service instructions may cause personal injury or death.

After the engine has stopped, you must wait for 10 minutes to allow the fuel pressure to be purged from the high-pressure fuel lines before any service or repair is performed on the engine fuel lines. The 10 minute wait will also allow static charge to dissipate from the low-pressure fuel system.

Ensure that the engine is stopped. Inspect all lines and hoses for wear or for deterioration. Ensure that the hoses are correctly routed. The lines and hoses must have adequate support and secure clamps. If any fuel lines or fuel hoses become kinked, the fuel line or fuel hose must be replaced. Refer to the Disassembly and Assembly manual for more information.

Oil filters and fuel filters must be correctly installed. The filter housings must be tightened to the correct torque. Refer to the Disassembly and Assembly manual for more information.



Illustration 12

g00704059

Use caution when you are refueling an engine. Do not smoke while you are refueling an engine. Do not refuel an engine near open flames or sparks. Always stop the engine before refueling.

Avoid static electricity risk when fueling. Ultra-low Sulfur Diesel fuel (ULSD fuel) poses a greater static ignition hazard than earlier diesel formulations with a higher sulfur content. Avoid death or serious injury from fire or explosion. Consult your fuel or fuel system supplier to ensure that the delivery system is in compliance with fueling standards for proper grounding and bonding practices.

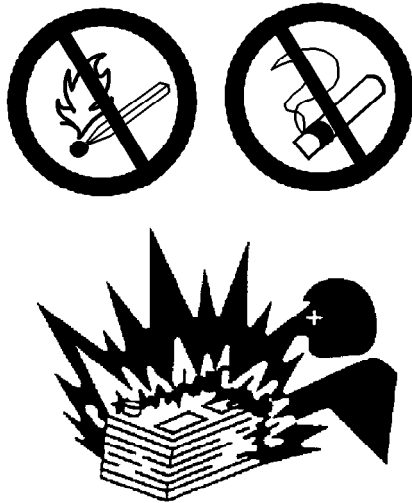

Illustration 13

g00704135

Gases from a battery can explode. Keep any open flames or sparks away from the top of a battery. Do not smoke in battery charging areas.

Never check the battery charge by placing a metal object across the terminal posts. Use a voltmeter or a hydrometer.

Incorrect jumper cable connections can cause an explosion that can result in injury. Refer to the Operation Section of this manual for specific instructions.

Do not charge a frozen battery. A frozen battery may cause an explosion.

The batteries must be kept clean. The covers (if equipped) must be kept on the cells. Use the recommended cables, connections, and battery box covers when the engine is operated.

Fire Extinguisher

Make sure that a fire extinguisher is available. Be familiar with the operation of the fire extinguisher. Inspect the fire extinguisher and service the fire extinguisher regularly. Obey the recommendations on the instruction plate.

Ether

WARNING

Do not use aerosol types of starting aids such as ether. Such use could result in an explosion and personal injury.

Ether is flammable and poisonous.

Do not smoke while you are replacing an ether cylinder.

Do not store ether cylinders in living areas or in the engine compartment. Do not store ether cylinders in direct sunlight or in temperatures above 49° C (120° F). Keep ether cylinders away from open flames or sparks.

Lines, Tubes, and Hoses

Do not bend high-pressure lines. Do not strike high-pressure lines. Do not install any lines that are damaged.

Leaks can cause fires. Consult your Perkins dealer or your Perkins distributor for replacement parts.

Replace the parts if any of the following conditions are present:

- High-pressure fuel line or lines are removed.
- End fittings are damaged or leaking.
- Outer coverings are chafed or cut.
- Wires are exposed.
- Outer coverings are ballooning.
- Flexible parts of the hoses are kinked.
- Outer covers have embedded armoring.
- End fittings are displaced.

Make sure that all clamps, guards, and heat shields are installed correctly. During engine operation, correct installation will help to prevent vibration, rubbing against other parts, and excessive heat.

i02143194

Crushing Prevention and Cutting Prevention

Support the component correctly when work beneath the component is performed.

Unless other maintenance instructions are provided, never attempt adjustments while the engine is running.

Stay clear of all rotating parts and of all moving parts. Leave the guards in place until maintenance is performed. After the maintenance is performed, reinstall the guards.

Keep objects away from moving fan blades. The fan blades will throw objects or cut objects.

Safety Section
Mounting and Dismounting

When objects are struck, wear protective glasses in order to avoid injury to the eyes.

Chips or other debris may fly off objects when objects are struck. Before objects are struck, ensure that no one will be injured by flying debris.

i05768982

Mounting and Dismounting

Do not climb on the engine or the engine aftertreatment system. The engine and aftertreatment system have not been designed with mounting or dismounting locations.

Refer to the OEM for the location of foot and hand holds for your specific application.

i07671624

High Pressure Fuel Lines

WARNING

Contact with high pressure fuel may cause fluid penetration and burn hazards. High pressure fuel spray may cause a fire hazard. Failure to follow these inspection, maintenance and service instructions may cause personal injury or death.

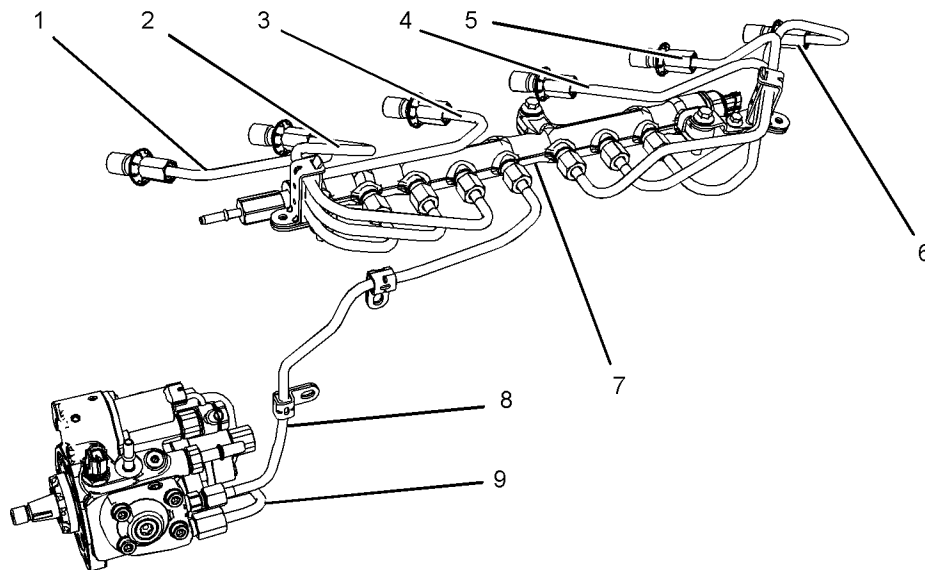

Illustration 14

g01877473

(1) High-pressure line
(2) High-pressure line
(3) High-pressure line

(4) High-pressure line
(5) High-pressure line
(6) High-pressure line

(7) High-pressure fuel manifold (rail)
(8) High-pressure line
(9) Fuel transfer line that is high pressure

The high-pressure fuel lines are the fuel lines that are between the high-pressure fuel pump and the high-pressure fuel manifold and the fuel lines that are between the fuel manifold and cylinder head. These fuel lines are different from fuel lines on other fuel systems.

The differences are as follows:

- The high-pressure fuel lines are constantly charged with high pressure while the engine is in operation and up to 10 minutes after the engine has stopped.
- The internal pressures of the high-pressure fuel lines are higher than other types of fuel system.
- The high-pressure fuel lines are formed to shape and then strengthened by a special process.

Do not step on the high-pressure fuel lines. Do not deform the high-pressure fuel lines. Do not bend or strike the high-pressure fuel lines. Deformation or damage of the high-pressure fuel lines may cause a point of weakness and potential failure.

Do not check the high-pressure fuel lines with the engine or the starting motor in operation. After the engine has stopped, you must wait for 10 minutes to allow the fuel pressure to be purged from the high-pressure fuel lines before any service or repair is performed on the engine fuel lines. The 10 minute wait will also allow static charge to dissipate from the low-pressure fuel system.

Do not loosen the high-pressure fuel lines to remove air from the fuel system. This procedure is not required.

Visually inspect the high-pressure fuel lines before the engine is started. This inspection should be performed each day.

If the engine is inspected whilst in operation, always use the correct inspection procedure to avoid a fluid penetration hazard. Refer to Operation and Maintenance Manual, "General hazard Information".

- Inspect the high-pressure fuel lines for damage, deformation, a nick, a cut, a crease, or a dent.
- Do not operate the engine with a fuel leak. If there is a leak, do not tighten the connection, to stop the leak. The connection must only be tightened to the recommended torque. Refer to Disassembly and Assembly, "Fuel injection lines - Remove and Fuel injection lines - Install".
- If the high-pressure fuel lines are torqued correctly and the high-pressure fuel lines are leaking, the high-pressure fuel lines must be replaced.
- Ensure that all clips on the high-pressure fuel lines are in place. Do not operate the engine with clips that are damaged, missing, or loose.

- Do not attach any other item to the high-pressure fuel lines.
- Loosened high-pressure fuel lines must be replaced. High-pressure fuel lines that have been removed must be replaced. Refer to Disassembly and assembly manual, "Fuel Injection Lines - Install".

i05874054

Before Starting Engine

NOTICE

For initial start-up of a new or rebuilt engine, and for start-up of an engine that has been serviced, make provision to shut the engine off should an overspeed occur. This may be accomplished by shutting off the air and/or fuel supply to the engine.

WARNING

Engine exhaust contains products of combustion which may be harmful to your health. Always start and operate the engine in a well ventilated area and, if in an enclosed area, vent the exhaust to the outside.

Inspect the engine for potential hazards.

Do not start the engine or move any of the controls if there is a "DO NOT OPERATE" warning tag or similar warning tag attached to the start switch or to the controls.

Before starting the engine, ensure that no one is on, underneath, or close to the engine. Ensure that the area is free of personnel.

If equipped, ensure that the lighting system for the engine is suitable for the conditions. Ensure that all lights work properly, if equipped.

All protective guards and all protective covers must be installed if the engine must be started in order to perform service procedures. To help prevent an accident that is caused by parts in rotation, work around the parts carefully.

Do not bypass the automatic shutoff circuits. Do not disable the automatic shutoff circuits. The circuits are provided in order to help prevent personal injury. The circuits are also provided in order to help prevent engine damage.

See the Service Manual for repairs and for adjustments.

i09664847

i02234873

Engine Starting

WARNING

Do not use aerosol types of starting aids such as ether. Such use could result in an explosion and personal injury.

If a warning tag is attached to the engine start switch, or to the controls DO NOT start the engine or move the controls. Consult with the person that attached the warning tag before the engine is started.

All protective guards and all protective covers must be installed if the engine must be started to perform service procedures. To help prevent an accident that is caused by parts in rotation, work around the parts carefully.

Start the engine from the operator's compartment or from the engine start switch.

Always start the engine according to the procedure described in the Operation and Maintenance Manual, "Engine Starting" topic in the Operation Section. Knowing the correct procedure will help to prevent major damage to the engine components. Knowing the procedure will also help to prevent personal injury.

To ensure that the jacket water heater (if equipped) and/or the lube oil heater (if equipped) is working correctly, check the water temperature gauge. Also, check the oil temperature gauge during the heater operation.

WARNING

Engine exhaust contains products of combustion which may be harmful to your health. Always start and operate the engine in a well ventilated area and, if in an enclosed area, vent the exhaust to the outside.

Note: The engine is equipped with a device for cold starting. If the engine will be operated in very cold conditions, an extra cold starting aid may be required. Normally, the engine will be equipped with the correct type of starting aid for the region of operation.

These engines are equipped with a glow plug starting aid in each cylinder which heats the intake air to improve starting. Some Perkins engines may have a cold starting system that is controlled by the ECM which allows a controlled flow of ether into the engine. The ECM will disconnect the glow plugs before the ether is introduced. This system would be installed at the factory.

Engine Stopping

Stop the engine according to the procedure in the Operation and Maintenance Manual, "Engine Stopping (Operation Section)" in order to avoid overheating of the engine and accelerated wear of the engine components.

Use the Emergency Stop Button (if equipped) ONLY in an emergency situation. Do not use the Emergency Stop Button for normal engine stopping. After an emergency stop, DO NOT start the engine until the problem that caused the emergency stop has been corrected.

Stop the engine if an overspeed condition occurs during the initial start-up of a new engine or an engine that has been overhauled.

To stop an electronically controlled engine, cut the power to the engine and/or shutting off the air supply to the engine.

i04193189

Electrical System

Never disconnect any charging unit circuit or battery circuit cable from the battery when the charging unit is operating. A spark can cause the combustible gases that are produced by some batteries to ignite.

To help prevent sparks from igniting combustible gases that are produced by some batteries, the negative "-" cable should be connected last from the external power source to the primary position for grounding.

Check the electrical wires daily for wires that are loose or frayed. Tighten all loose electrical connections before the engine is started. Repair all frayed electrical wires before the engine is started. See the Operation and Maintenance Manual for specific starting instructions.

Grounding Practices

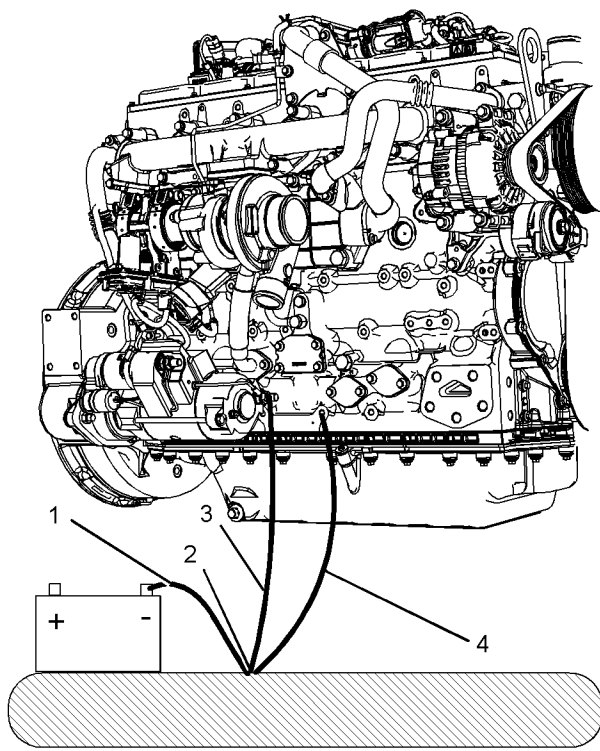

Illustration 15

g02383098

Typical example

- (1) Ground to the battery
- (2) Primary position for grounding
- (3) Ground to the starting motor
- (4) Ground to the engine block

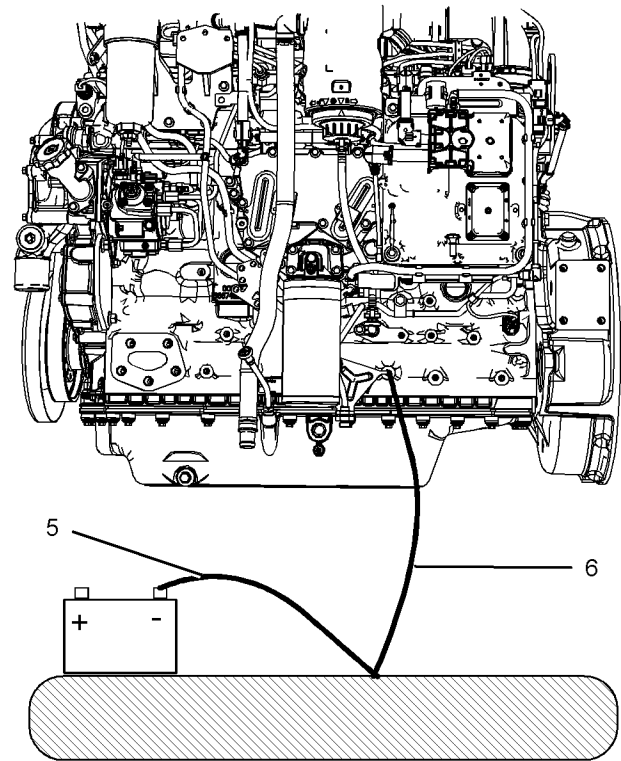

Illustration 16

g02383099

Typical example

- (5) Ground to the battery
- (6) Ground to the cylinder block

Correct grounding for the engine electrical system is necessary for optimum engine performance and reliability. Incorrect grounding will result in uncontrolled electrical circuit paths and in unreliable electrical circuit paths.

Uncontrolled electrical circuit paths can result in damage to the crankshaft bearing journal surfaces and to aluminum components.

Engines that are installed without engine-to-frame ground straps can be damaged by electrical discharge.

To ensure that the engine and the engine electrical systems function correctly, an engine-to-frame ground strap with a direct path to the battery must be used. This path may be provided by way of a direct engine ground to the frame.

The connections for the grounds should be tight and free of corrosion. The engine alternator must be grounded to the negative "-" battery terminal. The grounding wire must be adequate to handle the full charging current of the alternator.

The power supply connections and the ground connections for the engine electronics should always be from the isolator to the battery.

i03642610

Engine Electronics

WARNING

Tampering with the electronic system installation or the OEM wiring installation can be dangerous and could result in personal injury or death and/or engine damage.

WARNING

Electrical Shock Hazard. The electronic unit injectors use DC voltage. The ECM sends this voltage to the electronic unit injectors. Do not come in contact with the harness connector for the electronic unit injectors while the engine is operating. Failure to follow this instruction could result in personal injury or death.

This engine has a comprehensive, programmable Engine Monitoring System. The Electronic Control Module (ECM) has the ability to monitor the engine operating conditions. If any of the engine parameters extend outside an allowable range, the ECM will initiate an immediate action.

The following actions are available for engine monitoring control:

- Warning
- Derate
- Shutdown

The following monitored engine operating conditions have the ability to limit engine speed and/or the engine power:

- Engine Coolant Temperature
- Engine Oil Pressure
- Engine Speed
- Intake Manifold Air Temperature
- Engine Intake Throttle Valve Fault
- Wastegate Regulator
- Supply Voltage to Sensors
- Fuel Pressure in Manifold (Rail)
- NOx Reduction System

- Engine Aftertreatment System

The Engine Monitoring package can vary for different engine models and different engine applications. However, the monitoring system and the engine monitoring control will be similar for all engines.

Note: Many of the engine control systems and display modules that are available for Perkins Engines will work in unison with the Engine Monitoring System. Together, the two controls will provide the engine monitoring function for the specific engine application. Refer to Troubleshooting for more information on the Engine Monitoring System.

Product Information Section

Model Views

i04171351

Model View Illustrations

The following model views show typical features of the engine. Due to individual applications, your engine may appear different from the illustrations.

Engine views

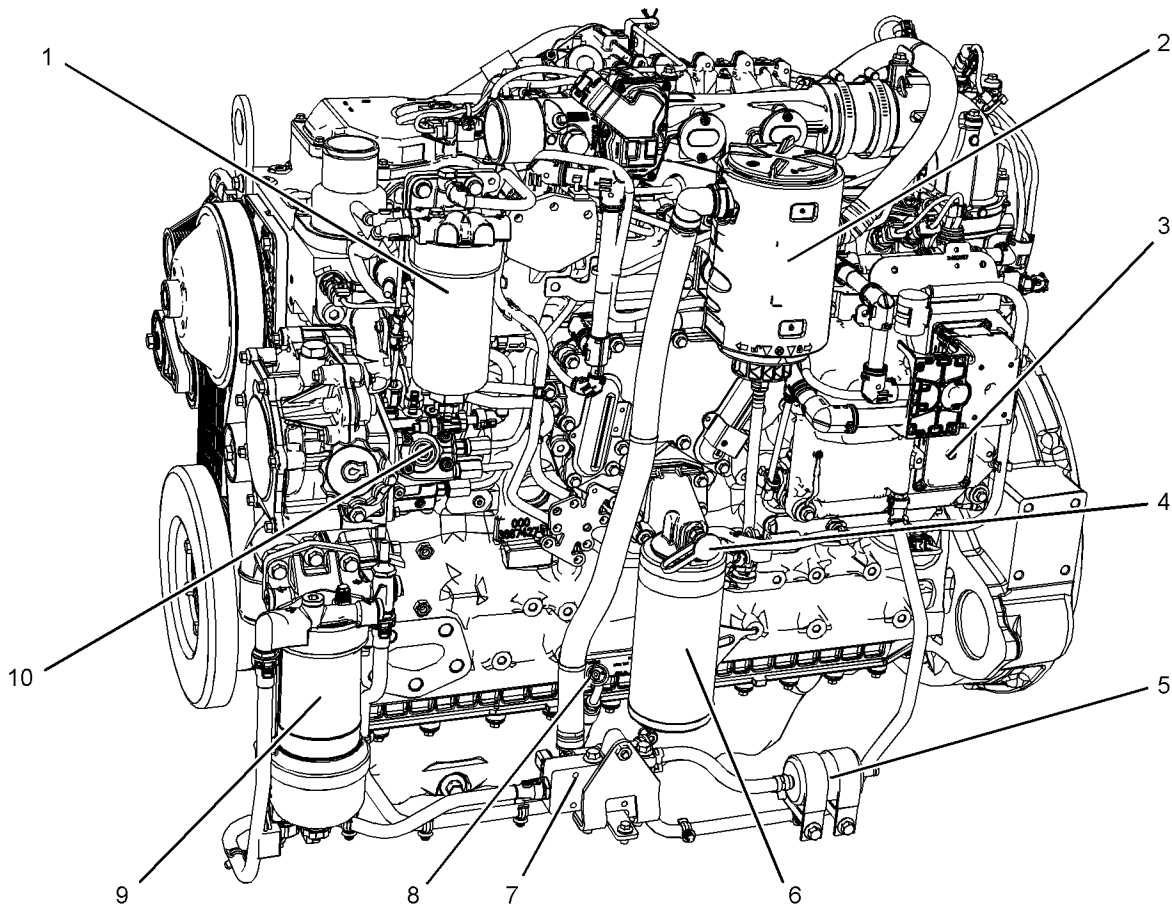

Illustration 17

g02361696

Typical example

- | | | |
|-------------------------------------|--------------------------|------------------------------|
| (1) Secondary fuel filter | (5) Fuel strainer | (9) Primary fuel filter |
| (2) Crankcase breather | (6) Oil filter | (10) High-pressure fuel pump |
| (3) Electronic control module (ECM) | (7) Fuel priming pump | |
| (4) Oil sampling valve | (8) Oil gauge (Dipstick) | |

The location of the in-line strainer (5) and the priming pump (7) will depend on the application.

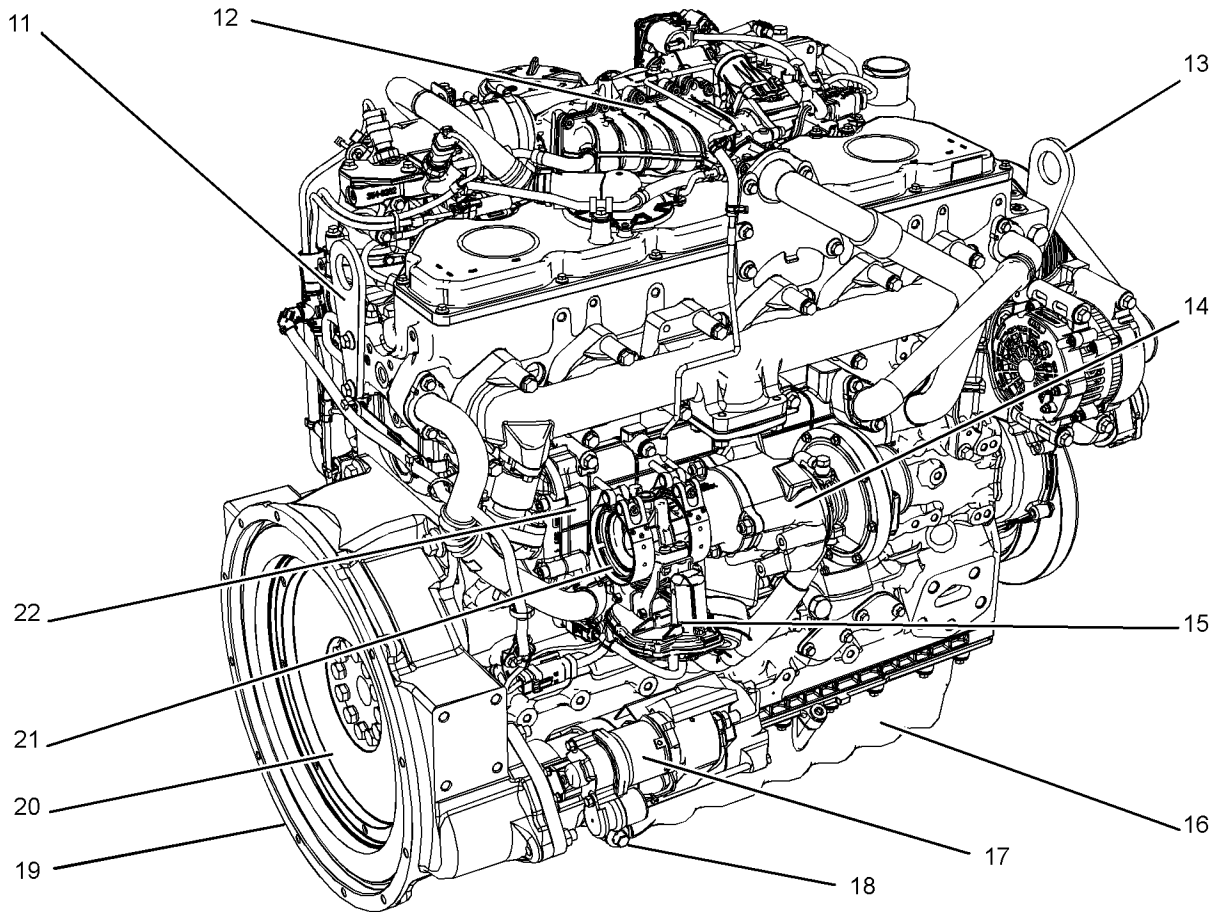

Illustration 18

g02361697

Typical example

(11) Rear lifting eye
(12) NOx reduction system (NRS)
(13) Front lifting eye
(14) Turbocharger

(15) Back pressure valve
(16) Engine oil pan (Sump)
(17) Starting motor
(18) Engine oil drain plug

(19) Flywheel housing
(20) Flywheel
(21) Exhaust outlet
(22) Exhaust gas cooler

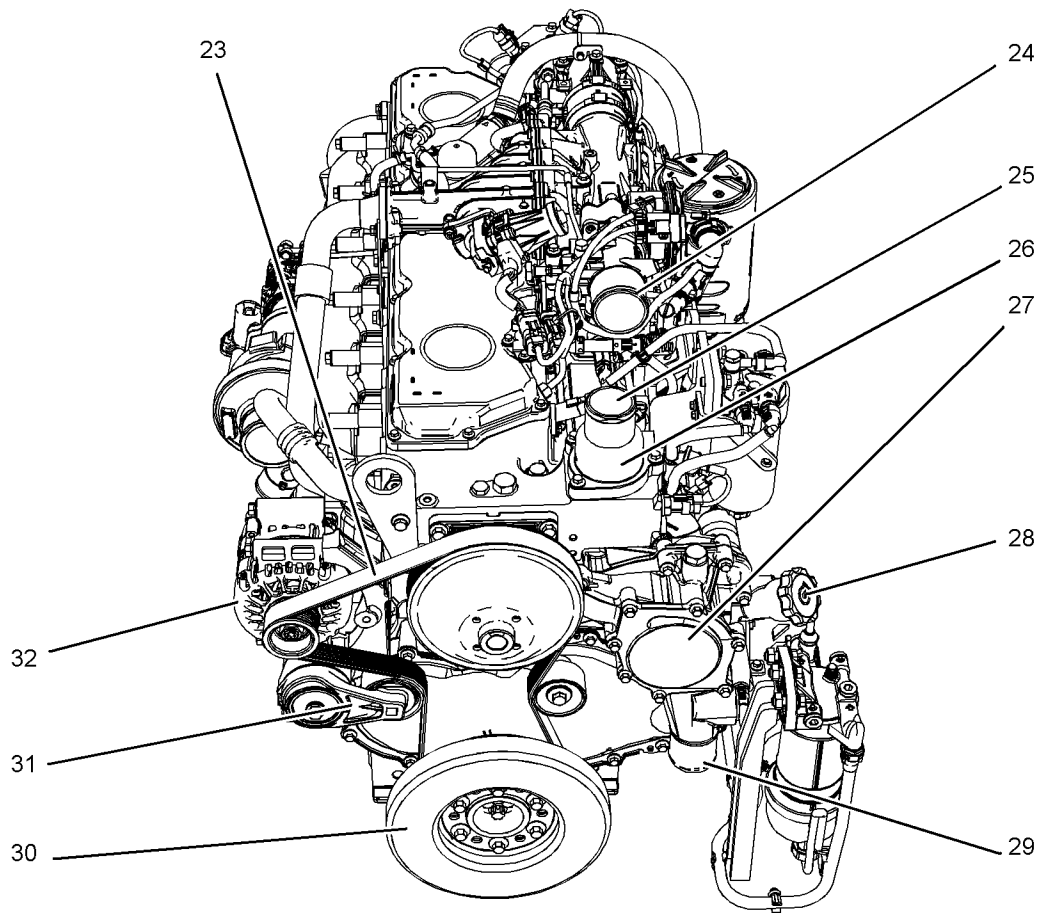

Illustration 19

g02379457

Typical example

(23) Belt
 (24) Connection for air inlet
 (25) Outlet connection for the coolant

(26) Water temperature regulator housing
 (Thermostat housing)
 (27) Water pump
 (28) Oil filler

(29) Inlet connection for the Coolant
 (30) Vibration damper
 (31) Belt tensioner
 (32) Alternator

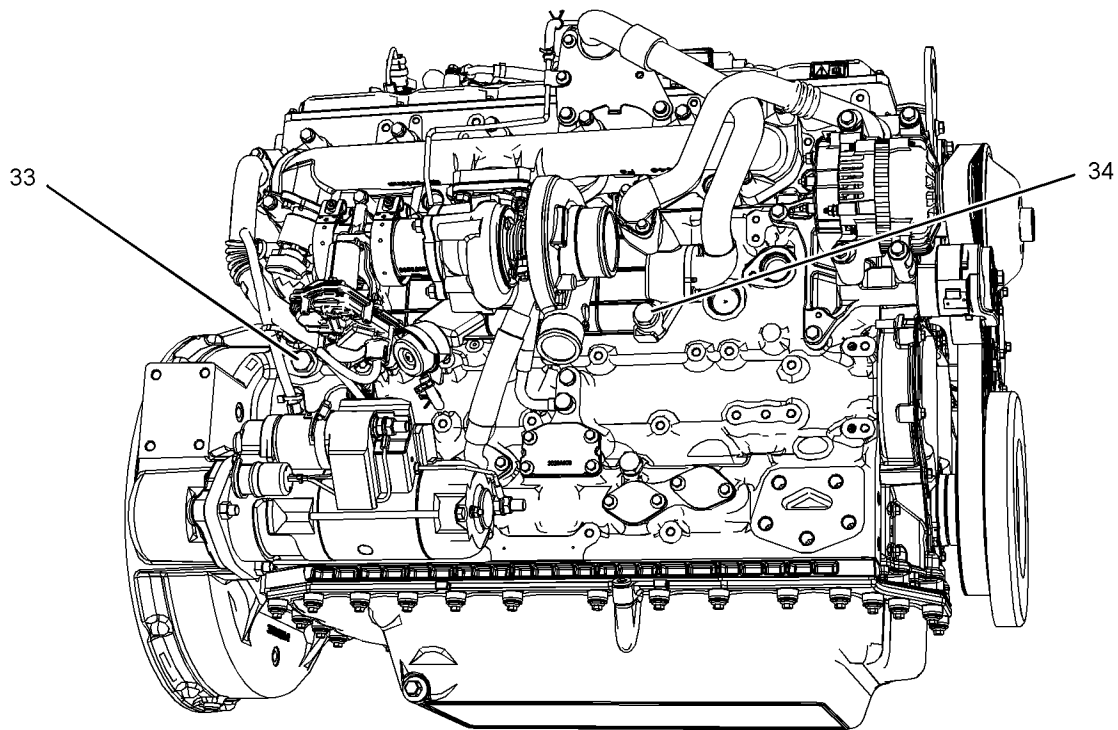

Illustration 20

g02381218

Typical example

(33) Coolant drain plug for cylinder block

(34) Coolant drain plug for exhaust gas cooler

Engine Aftertreatment System

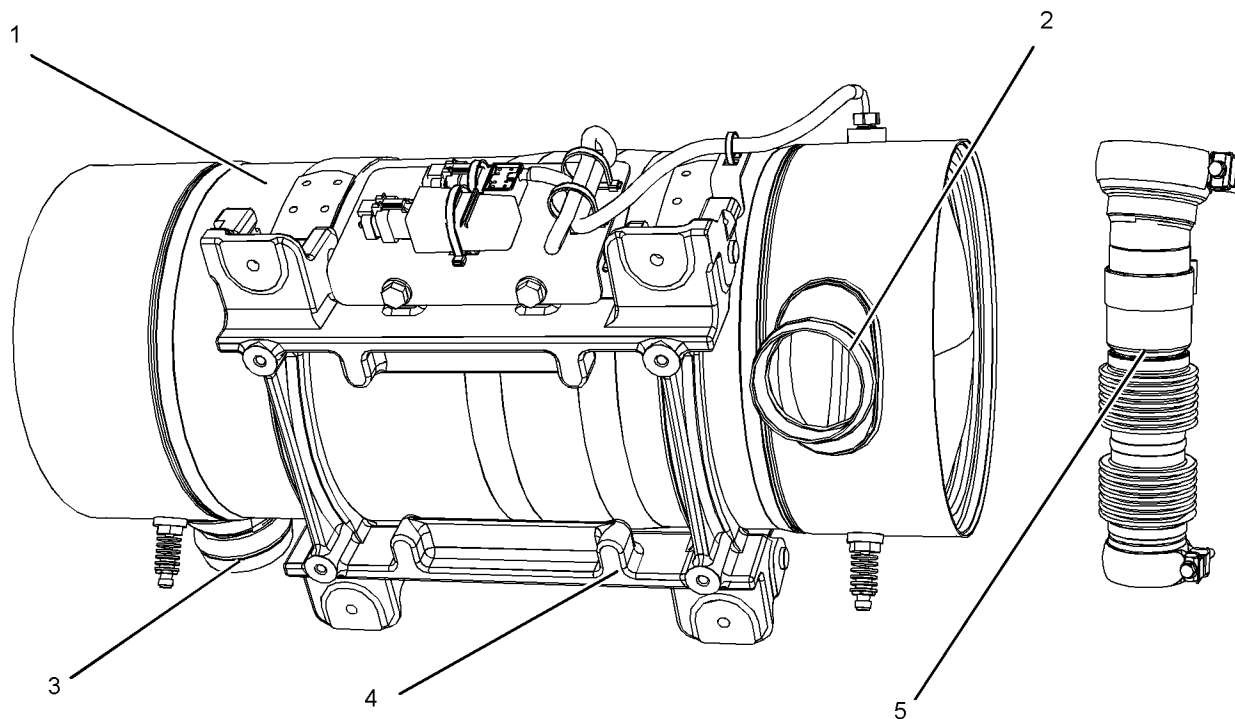

Illustration 21

g02384560

Typical example

(1) Clean emissions module (CEM)
(2) Inlet connection

(3) Outlet connection
(4) Mounting cradle

(5) Flexible exhaust pipe from engine to CEM

i04340730

Engine Description

The Perkins 1206-E66 Industrial Engine has the following characteristics.

- In-line Six cylinder
- Four stroke cycle
- Turbocharged charge cooled

Engine Specifications

Note: The front end of the engine is opposite the flywheel end of the engine. The left and the right sides of the engine are determined from the flywheel end. The number 1 cylinder is the front cylinder.

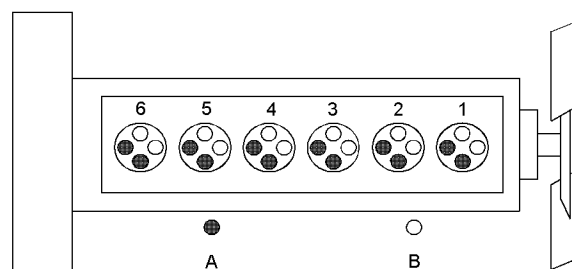

Illustration 22

g01127295

Cylinder and valve location

(A) Exhaust valves
(B) Inlet valves

Table 1

Engine Specifications	
Operating Range (rpm)	900 to 2800 ⁽¹⁾
Number of Cylinders	6 In-Line
Bore	105 mm (4.13 inch)
Stroke	127 mm (5 inch)
Power	129.4 kW (173.52 hp)
Aspiration	Turbocharged charge cooled
Compression Ratio	16.5:1
Displacement	6.6 L (402.7 cubic inch)
Firing Order	1-5-3-6-2-4
Rotation (flywheel end)	Counterclockwise

(1) The operating rpm is dependent on the engine rating, the application, and the configuration of the throttle.

Electronic Engine Features

The engine operating conditions are monitored. The Electronic Control Module (ECM) controls the response of the engine to these conditions and to the demands of the operator. These conditions and operator demands determine the precise control of fuel injection by the ECM. The electronic engine control system provides the following features:

- Engine monitoring
- Engine speed governing
- Control of the injection pressure
- Cold start strategy
- Automatic air/fuel ratio control
- Torque rise shaping
- Injection timing control
- System diagnostics
- Low temperature regeneration

For more information on electronic engine features, refer to the Operation and Maintenance Manual, "Features and Controls" topic (Operation Section).

Engine Diagnostics

The engine has built-in diagnostics in order to ensure that the engine systems are functioning correctly. The operator will be alerted to the condition by a "Stop or Warning" lamp. Under certain conditions, the engine horsepower and the vehicle speed may be limited. The electronic service tool may be used to display the diagnostic codes.

There are three types of diagnostic codes: active, logged and event.

Most of the diagnostic codes are logged and stored in the ECM. For additional information, refer to the Operation and Maintenance Manual, "Engine Diagnostics" topic (Operation Section).

The ECM provides an electronic governor that controls the injector output in order to maintain the desired engine rpm.

Engine Cooling and Lubrication

The cooling system and lubrication system consists of the following components:

- Gear-driven centrifugal water pump
- Water temperature regulator which regulates the engine coolant temperature
- Gear-driven rotor type oil pump
- Oil cooler

The engine lubricating oil is supplied by a rotor type oil pump. The engine lubricating oil is cooled and the engine lubricating oil is filtered. The bypass valve can provide unrestricted flow of lubrication oil to the engine if the oil filter element should become plugged.

Engine efficiency, efficiency of emission controls, and engine performance depend on adherence to proper operation and maintenance recommendations. Engine performance and efficiency also depend on the use of recommended fuels, lubrication oils, and coolants. Refer to this Operation and Maintenance Manual, "Maintenance Interval Schedule" for more information on maintenance items.

Aftertreatment System

The aftertreatment system is approved for use by Perkins. In order to be emission-compliant only the approved Perkins aftertreatment system must be used on a Perkins engine.

Clean Emission Module (CEM)

The CEM comprises of two main components in a single unit, the Diesel Oxidation Catalyst DOC and the Diesel Particulate Filter DPF. The function of the CEM is to ensure that the engine exhaust meets the required emissions regulation for the country of operation.

The engine exhaust is connected by a flexible pipe to the CEM. The exhaust gases pass through the DOC in order to remove contaminants, carbon monoxide, and hydrocarbons. The exhaust gases then enter the DPF where any particulate matter soot and ash will be trapped.

The CEM uses a passive regeneration process to ensure that normal operation of the engine removes the soot. The soot is removed at an equal rate of which the soot is captured. The ash remains in the DPF and must be removed at an engine overhaul.

Engine Service Life

Engine efficiency and maximum utilization of engine performance depend on the adherence to proper operation and maintenance recommendations. In addition, use recommended fuels, coolants, and lubricants. Use the Operation and Maintenance Manual as a guide for required engine maintenance.

Expected engine life is generally predicted by the average power that is demanded. The average power that is demanded is based on fuel consumption of the engine over a period of time. Reduced hours of operation at full throttle and/or operating at reduced throttle settings result in a lower average power demand. Reduced hours of operation will increase the length of operating time before an engine overhaul is required. For more information, refer to the Operation and Maintenance Manual, "Overhaul Considerations" topic (Maintenance Section).

Aftermarket Products and Perkins Engines

Perkins does not warrant the quality or performance of non-Perkins fluids and filters.

When auxiliary devices, accessories, or consumables (filters, additives, catalysts,) which are made by other manufacturers are used on Perkins products, the Perkins warranty is not affected simply because of such use.

However, failures that result from the installation or use of other manufacturers devices, accessories, or consumables are NOT Perkins defects. Therefore, the defects are NOT covered under the Perkins warranty.

Product Identification Information

i03865704

Plate Locations and Film Locations (Engine Aftertreatment System)

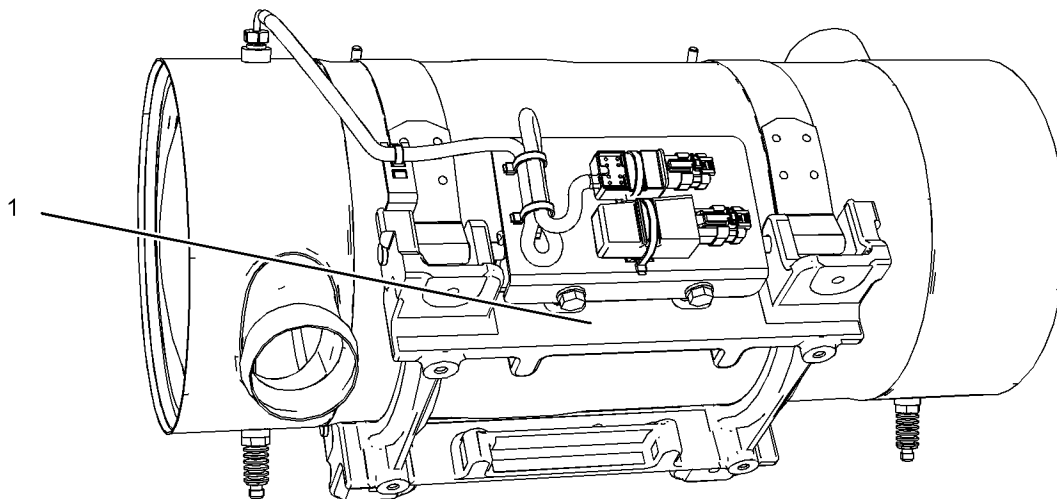

Illustration 23
Typical example

g02109488

The module arrangement exhaust plate is installed on the mounting plate (1). The location of the arrangement plate mounting plate can alter depending on the application.

Record the information that is on the plate. This information identifies the engine aftertreatment system. This information will be required by your Perkins distributor. The information is essential in order to be emissions compliant.

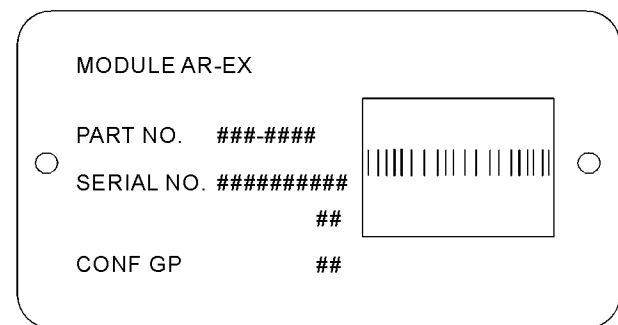

Illustration 24
Module Arrangement Exhaust Plate

g02109493

i03867276

Reference Numbers

Information for the following items may be needed to order parts. Locate the information for your engine. Record the information in the appropriate space. Make a copy of this list for a record. Keep the information for future reference.

Record for Reference

Engine Model _____

Engine Serial number _____

Engine Low Idle rpm _____

Engine Full Load rpm _____
 Primary Fuel Filter _____
 Water Separator Element _____
 Secondary Fuel Filter Element _____
 Lubrication Oil Filter Element _____
 Auxiliary Oil Filter Element _____
 Total Lubrication System Capacity _____
 Total Cooling System Capacity _____
 Air Cleaner Element _____
 Drive Belt _____

Engine Aftertreatment System

Part Number _____
 Serial Number _____

i04274850

Emissions Certification Film

An emission label is installed on the front gear cover.

Note: A second emission label will be supplied with the engine. If necessary, the second emission label will be installed on the application by the original equipment manufacturer.

EMISSION CONTROL INFORMATION		
Engine family: #####13#####		
Displacement: #4##		
EPA/California Family: #####12#####		
EPA/California Family Max. Values		
Fuel rate: ##5## mm3/Stk		
Initial timing: #3# DEG ATDC		
THIS ENGINE COMPLIES WITH U.S. EPA REGULATIONS FOR #### NONROAD AND STATIONARY DIESEL ENGINES AND CALIFORNIA OFF-ROAD DIESEL ENGINES		
ULTRA LOW SULFUR FUEL ONLY		
Power Category #3#<kW<#3#		Engine Type
		Factory Set Reset if Applicable
FEL (g/kWh)	<input type="checkbox"/>	##### #3kW <input type="checkbox"/>
NMHC: #4##	<input type="checkbox"/>	##### #3kW <input type="checkbox"/>
NOx: #4##	<input type="checkbox"/>	##### #3kW <input type="checkbox"/>
PM: ##5##	<input type="checkbox"/>	##### #3kW <input type="checkbox"/>
Emission Control System	<input type="checkbox"/>	##### #3kW <input type="checkbox"/>
#3# #3# #3#	Use service tool to verify current engine settings	
#3# #3# #3#		
List No. ##7###	Serial No. ###8###	Label No. #####
[Empty Box]		
120 R - ##6###		
#####28#####		
MLIT #####20#####		
Date of Manufacture: #3# #4##		

Illustration 25

g02443596

Typical example

Operation Section

Lifting and Storage

i07434782

Product Lifting (Engine)

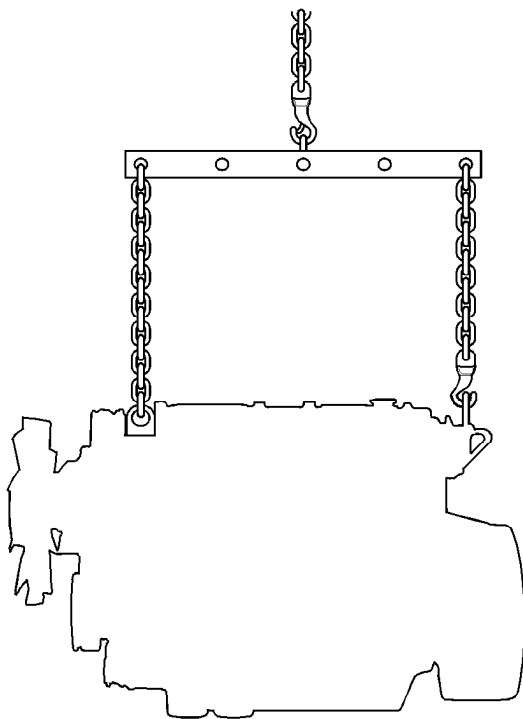

Illustration 26

g01097527

NOTICE

Never bend the eyebolts and the brackets. Only load the eyebolts and the brackets under tension. Remember that the capacity of an eyebolt is less as the angle between the supporting members and the object becomes less than 90 degrees.

When it is necessary to remove a component at an angle, only use a link bracket that is properly rated for the weight.

NOTICE

Always inspect lifting eyebolts and all other lifting equipment for damage before performing any lifting. Never Bend the eyebolts and the brackets. Never perform product lifting if the components are damaged.

Use a hoist to remove heavy components. Use an adjustable lifting beam to lift the engine. All supporting members (chains and cables) should be parallel to each other. The chains and cables should be perpendicular to the top of the object that is being lifted.

Some removals require lifting the fixtures in order to obtain correct balance and safety.

To remove the engine ONLY, use the lifting eyes that are on the engine.

Lifting eyes are designed and installed for specific engine arrangements. Alterations to the lifting eyes and/or the engine make the lifting eyes and the lifting fixtures obsolete. If alterations are made, ensure that correct lifting devices are provided. Consult your Perkins dealer or your Perkins distributor for information regarding fixtures for correct engine lifting.

i07442887

i04084189

Product Lifting (Clean Emission Module)

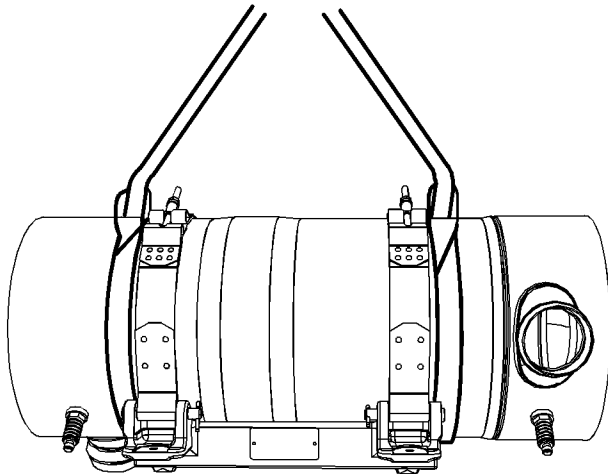

Illustration 27

g02385036

NOTICE

Always inspect lifting eyebolts and all other lifting equipment for damage before performing any lifting. Never bend the eyebolts and the brackets. Never perform product lifting if components are damaged. Only load the eyebolts and the brackets under tension. Remember that the capacity of an eyebolt is less as the angle between the supporting members and the object becomes less than 90 degrees.

Ensure that the correct clothing is worn, refer to this Operation and Maintenance Manual, "General Hazard Information".

The weight of the clean emission module (CEM) when laden is approximately 50 kg (110 lb). Two suitable double looped slings are required to lift the CEM. Also a suitable hoist will be required to remove and install the assembly.

The slings must be attached to the CEM in the positions as shown in illustration 27 .

Ensure that the slings only contact the body of the CEM. A test lift may be required to achieve the correct balance of the assembly.

Some applications may require a frame or jig to lift the CEM. A frame or jig must only be connected to the cradle of the CEM. Refer to the OEM for more information.

Product Storage (Engine and Aftertreatment)

Perkins are not responsible for damage which may occur when an engine is in storage after a period in service.

Your Perkins dealer or your Perkins distributor can assist in preparing the engine for extended storage periods.

Condition for Storage

The engine must be stored in a water proof building. The building must be kept at a constant temperature. Engines that are filled with Perkins ELC will have coolant protection to an ambient temperature of -36°C (-32.8°F). The engine must not be subjected to extreme variations in temperature and humidity.

Storage Period

An engine can be stored for up to 6 months provided all the recommendation are adhered to.

Storage Procedure

Keep a record of the procedure that has been completed on the engine.

Note: Do not store an engine that has biodiesel in the fuel system.

1. Ensure that the engine is clean and dry.
 - a. If the engine has been operated using biodiesel, the system must be drained and new filters installed. The fuel tank will require flushing.
 - b. Fill the fuel system with an ultra low sulfur fuel. For more information on acceptable fuels refer to this Operation and Maintenance Manual, "Fluid recommendations". Operate the engine for 15 minutes in order to remove all biodiesel from the system.
2. Drain any water from the primary filter water separator. Ensure that the fuel tank is full.
3. The engine oil will not need to be drained in order to store the engine. Provided the correct specification of engine oil is used the engine can be stored for up to 6 months. For the correct specification of engine oil refer to this Operation and Maintenance Manual, "Fluid recommendations".

4. Remove the drive belt from the engine.

Sealed Coolant System

Ensure that the cooling system is filled with Perkins ELC, or an antifreeze that meets "ASTM D6210" specification.

Open Cooling System

Ensure that all cooling drain plugs have been opened. Allow the coolant to drain. Install the drain plugs. Place a vapor phase inhibitor into the system. The coolant system must be sealed once the vapor phase inhibitor has been introduced. The effect of the vapor phase inhibitor will be lost if the cooling system is open to the atmosphere.

For maintenance procedures ref to this Operation and Maintenance Manual.

Aftertreatment

No special procedures are required. The exhaust outlet of the aftertreatment should be capped. Before storing, the engine and the aftertreatment must be enclosed in a cover.

Monthly Checks

The crankshaft must be rotated in order to change the spring loading on the valve train. Rotate the crankshaft more than 180 degrees. Visibly check for damage or corrosion to the engine and aftertreatment.

Ensure that the engine and aftertreatment are covered completely before storage. Log the procedure in the record for the engine.

Gauges and Indicators

i04220531

Gauges and Indicators

Your engine may not have the same gauges or all of the gauges that are described. For more information about the gauge package, see the OEM information.

Gauges provide indications of engine performance. Ensure that the gauges are in good working order. Determine the normal operating range by observing the gauges over a period of time.

Noticeable changes in gauge readings indicate potential gauge or engine problems. Problems may also be indicated by gauge readings that change even if the readings are within specifications. Determine and correct the cause of any significant change in the readings. Consult your Perkins distributor for assistance.

Some engine applications are equipped with Indicator Lamps. Indicator lamps can be used as a diagnostic aid. There are two lamps. One lamp has an orange lens and the other lamp has a red lens.

These indicator lamps can be used in two ways:

- The indicator lamps can be used to identify the current operational status of the engine. The indicator lamps can also indicate that the engine has a fault. This system is automatically operated via the ignition switch.
- The indicator lamps can be used to identify active diagnostic codes. This system is activated by pressing the Flash Code button.

Refer to the Troubleshooting Guide, "Indicator Lamps" for further information.

NOTICE

If no oil pressure is indicated, STOP the engine. If maximum coolant temperature is exceeded, STOP the engine. Engine damage can result.



Engine Oil Pressure – The oil pressure should be greatest after a cold engine is started. The typical engine oil pressure with SAE10W40 is 350 to 450 kPa (50 to 65 psi) at rated rpm.

A lower oil pressure is normal at low idle. If the load is stable and the gauge reading changes, perform the following procedure:

1. Remove the load.
2. Stop the engine.

3. Check and maintain the oil level.



Jacket Water Coolant Temperature – Typical temperature range is 82° to 94° C (179.6° to 201.2°F). This temperature range will vary according to engine load and the ambient temperature.

A 100 kPa (14.5 psi) radiator cap must be installed on the cooling system. The maximum temperature for the cooling system is 108° C (226.4° F). This temperature is measured at the outlet for the water temperature regulator. The engine coolant temperature is regulated by the engine sensors and the engine ECM. This programming cannot be altered. An engine derate can occur if the maximum engine coolant temperature is exceeded.

If the engine is operating above the normal range, reduce the engine load. If high coolant temperatures are a frequent event, perform the following procedures:

1. Reduce the load and the engine rpm.
2. Determine if the engine must be shut down immediately or if the engine can be cooled by reducing the load.
3. Inspect the cooling system for leaks. If necessary, consult your Perkins distributor for assistance.



Tachometer – This gauge indicates engine speed (rpm). When the throttle control lever is moved to the full throttle position without load, the engine is running at high idle. The engine is running at the full load rpm when the throttle control lever is at the full throttle position with maximum rated load.

NOTICE

Operation at speeds exceeding high idle rpm should be kept to a minimum. Overspeeding can result in serious damage to the engine.



Ammeter – This gauge indicates the amount of charge or discharge in the battery charging circuit. Operation of the indicator should be to the "+" side of "0" (zero).



Fuel Level – This gauge indicates the fuel level in the fuel tank. The fuel level gauge operates when the "START/STOP" switch is in the "on" position.



Service Hour Meter – The gauge indicates total operating hours of the engine.

Indicator Lamps

There is four indicator lamps that are available.

- Shutdown Lamp
- Warning Lamp
- Wait to Start Lamp
- Low Oil Pressure Lamp

For information, refer to this manual, “Monitoring System (Table for the Indicator Lamps)” for the sequence of operation of the shutdown lamp and the warning lamp.

The function of the wait to start lamp is automatically controlled at engine start-up.

The function of the low oil pressure lamp is controlled by the engine ECM. If low oil pressure is detected, the lamp will be illuminated. The reason for the illumination of the low-pressure lamp should be investigated immediately.

All lamps will illuminate for 2 seconds in order to check that the lamps are functioning when the keyswitch is turned to the ON position. If any of the lamps stay illuminated, the reason for illumination should be investigated immediately.

Instrument panels and Displays

In order to monitor the engine a wide verity of instrument panels are available. These instrument panels can contain the indicator lamps and the gauges for the application.

Also available are mini power displays and performance monitors. These displays and monitors can show the operator the following engine information.

- The system configuration parameters
- The customer specified parameters
- Diagnostic codes
- Event codes
- Coolant temperature
- Oil temperature
- Oil pressure
- Intake temperature
- Intake pressure
- Atmospheric pressure
- Fuel temperature

Features and Controls

i04201172

Monitoring System (Table for the Indicator lamps)

Note: When in operation the amber warning lamp has three states, solid, flashing, and fast flashing. The sequence is to give a visual indication of the importance of the warning. Some application can have an audible warning installed.

Ensure that the engine maintenance is carried out at the correct intervals. A lack of maintenance can result in illumination of the warning lamp. For the correct intervals of maintenance, refer to the Operation and Maintenance Manual, "Maintenance Interval Schedule".

Table 2

Warning Lamp	Shutdown Lamp	Lamp State	Description of the Indication	Engine Status
On	On	Lamp Check	When the keyswitch is moved to the ON position, the lamps come on for 2 seconds and the lamps will then go off.	The keyswitch is in the ON position but the engine has not yet been cranked.
Off	Off	No Faults	With the engine in operation, there are no active warnings, diagnostic codes, or event codes.	The engine is operating with no detected faults.
On Solid	Off	Warning	Level 1 warning	The engine is operating normally but there is one or more faults with the electronic management system for the engine.
Flashing	Off	Warning	Level 2 warning	The engine continues to be operated, but the level of importance of the warning has increased. Depending on the particular fault and the severity the engine may be de-rated. The engine could be damaged if continued to be operated.
Flashing	On	Engine Shutdown	Level 3 warning If both the warning lamp and the shutdown lamp are in operation, this issue indicates one of the following conditions. 1. One or more of the shutdown values for the engine protection strategy has been exceeded. 2. A serious active diagnostic code has been detected. After a short time period, the engine may shut down.	The engine is either shutdown or an engine shutdown is imminent. One or more monitored engine parameters have exceeded the limit for an engine shutdown. This pattern of lamps can be caused by the detection of a serious active diagnostic code.

i04340829

Monitoring System

WARNING

If the Shutdown mode has been selected and the warning indicator activates, engine shutdown may take as little as 20 seconds from the time the warning indicator is activated. Depending on the application, special precautions should be taken to avoid personal injury. The engine can be re-started following shutdown for emergency maneuvers, if necessary.

NOTICE

The Engine Monitoring System is not a guarantee against catastrophic failures. Programmed delays and derate schedules are designed to minimize false alarms and provide time for the operator to stop the engine.

The following parameters are monitored:

- Coolant temperature
- Intake manifold air temperature
- Intake manifold air pressure
- Oil pressure
- Pressure in the fuel rail
- Engine speed/timing
- Fuel temperature
- Atmospheric pressure (Barometric pressure)
- The Inlet pressure and outlet pressure of the NOx reduction system
- Temperature of the NOx reduction system
- Water in fuel switch
- The amount of soot in the Diesel particulate filter

Programmable Options and Systems Operation

WARNING

If the Warning/Derate/Shutdown mode has been selected and the warning indicator activates, bring the engine to a stop whenever possible. Depending on the application, special precautions should be taken to avoid personal injury.

The engine can be programmed to the following modes:

“Warning”

The orange “Warning” lamp will turn “ON” and the warning signal is activated continuously in order to alert the operator that one or more of the engine parameters is not within normal operating range.

“Derate”

The orange warning lamp will be flashing. After the warning, the engine power will be derated.

The engine will be derated if the engine exceeds preset operational limits. The engine derate is achieved by restricting the amount of fuel that is available for each injection. The amount of this reduction of fuel is dependent on the severity of the fault that has caused the engine derate, typically up to a limit of 50%. This reduction in fuel results in a predetermined reduction in engine power.

“Shutdown”

The orange warning lamp will be flashing and the red shutdown lamp will be on solid. After the warning, the engine power will be derated. The engine will continue at the rpm of the set derate until a shutdown of the engine occurs. The engine can be restarted after a shutdown for use in an emergency.

A shutdown of the engine may occur in as little as 20 seconds. The engine can be restarted after a shutdown for use in an emergency. However, the cause of the initial shutdown may still exist. The engine may shut down again in as little as 20 seconds.

If there is a signal for high coolant temperature, there will be a 2 second delay in order to verify the condition.

If there is a signal for low oil pressure, there will be a 2 second delay in order to verify the condition.

For information on the operation of the warning lamps and the shutdown lamp, refer to this Operation and Maintenance Manual, “Monitoring System (Table for Indicator Lamps)”. For each of the programmed modes, refer to Troubleshooting Guide, “Indicator Lamps” for more information on Indicator Lamps.

For more information or assistance for repairs, consult your Perkins distributor or your Perkins dealer.

i04215952

Sensors and Electrical Components (Aftertreatment)

The illustration within the section shows the typical locations of the sensors and other electrical components on the industrial engine. Specific engine aftertreatment systems may appear different due to the application.

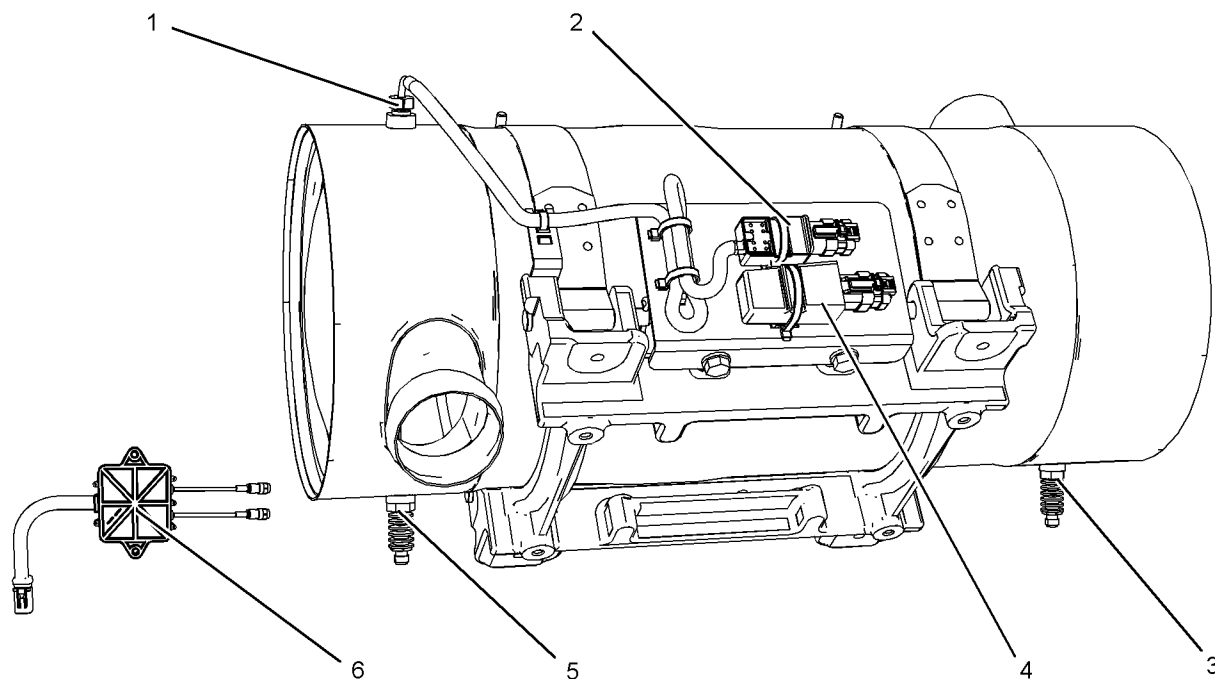

Illustration 28

g02395776

(1) Temperature Sensor
(2) Connector for Temperature Sensor

(3) Soot Sensor Connection
(4) Aftertreatment Identification Module

(5) Soot Sensor Connection
(6) Soot Sensor

Note: The location of the soot sensor will depend on the application.

i04220589

Sensors and Electrical Components

The Illustration within the section shows the typical locations of the sensors for a 1206E-66 Industrial Engine. Specific engines may appear different from the illustration due to differences in applications.

Operation Section
Sensors and Electrical Components

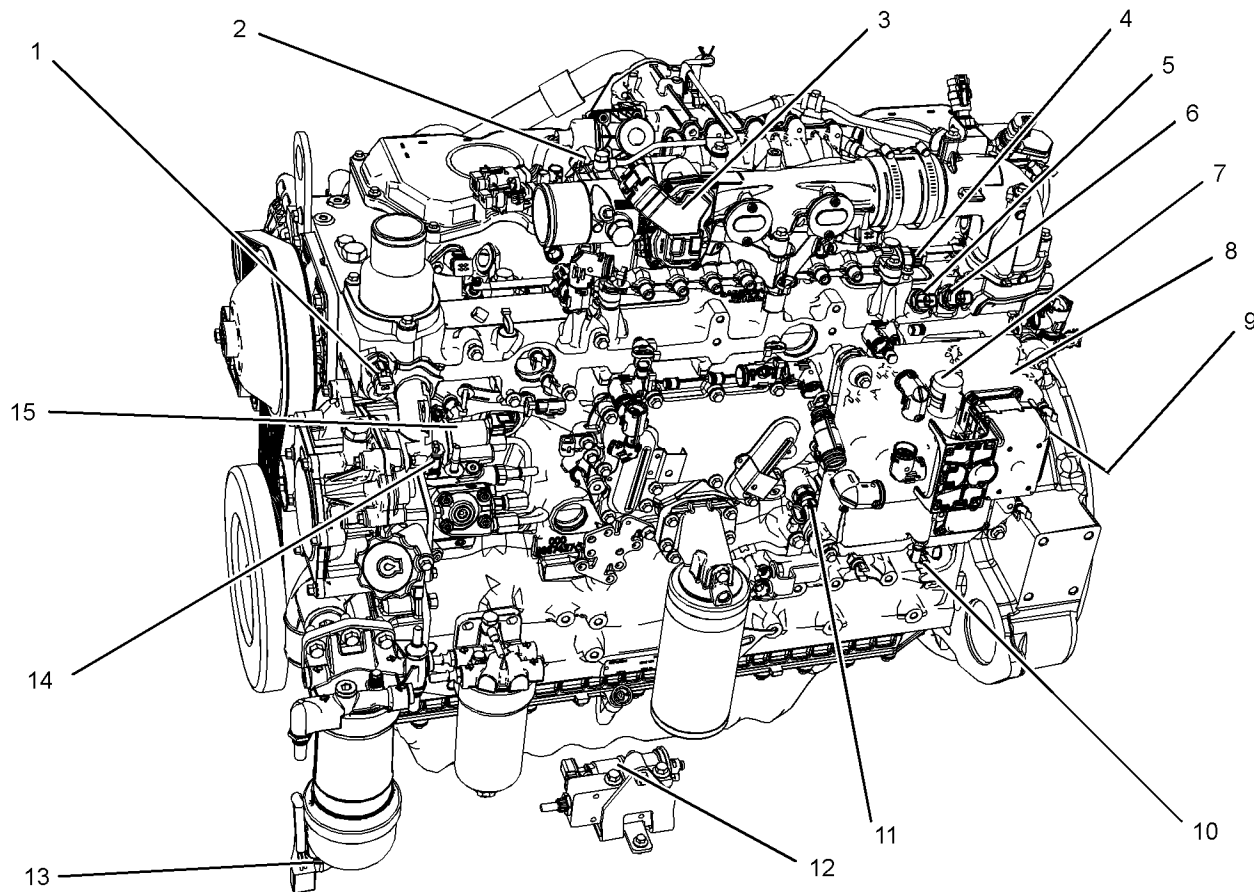

Illustration 29

g02392837

Typical example

- | | | |
|--|--|---|
| (1) Coolant Temperature Sensor | (6) Intake Manifold Pressure Sensor | (11) Oil Pressure Sensor |
| (2) Wastegate Regulator | (7) Diagnostic Connector | (12) Fuel Priming Pump |
| (3) Throttle valve | (8) Electronic Control Module (ECM) | (13) Water in Fuel Switch |
| (4) Fuel Pressure Sensor (Fuel Rail Pressure Sensor) | (9) Atmospheric Pressure Sensor (Barometric Pressure Sensor) | (14) Fuel Temperature Sensor |
| (5) Intake Manifold Air Temperature Sensor | (10) Primary Speed/Timing Sensor | (15) Solenoid for the High Pressure Fuel Pump |

Note: The location of the secondary fuel filter, the primary fuel filter, and the fuel priming pump will depend on the application. These locations will affect items (12, and 13).

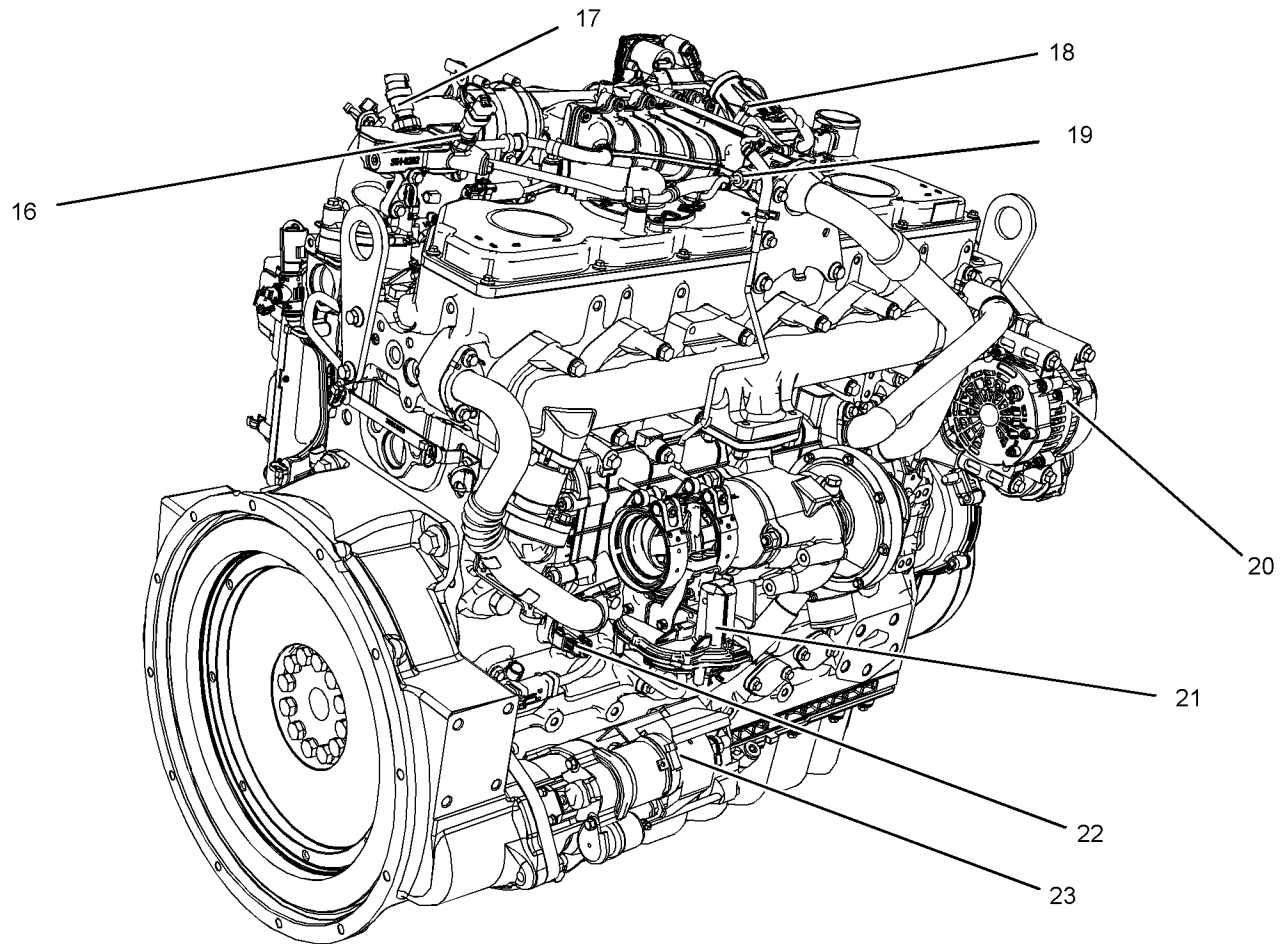

Illustration 30

g02392856

Typical example

(16) Inlet Pressure Sensor for the NOx
Reduction System (NRS)
(17) Outlet Pressure sensor for the NRS

(18) Control Valve for the NRS
(19) Temperature Sensor for the NRS
(20) Alternator

(21) Back Pressure Valve
(22) Secondary Speed/Timing Sensor
(23) Starter Motor

Operation Section
Sensors and Electrical Components

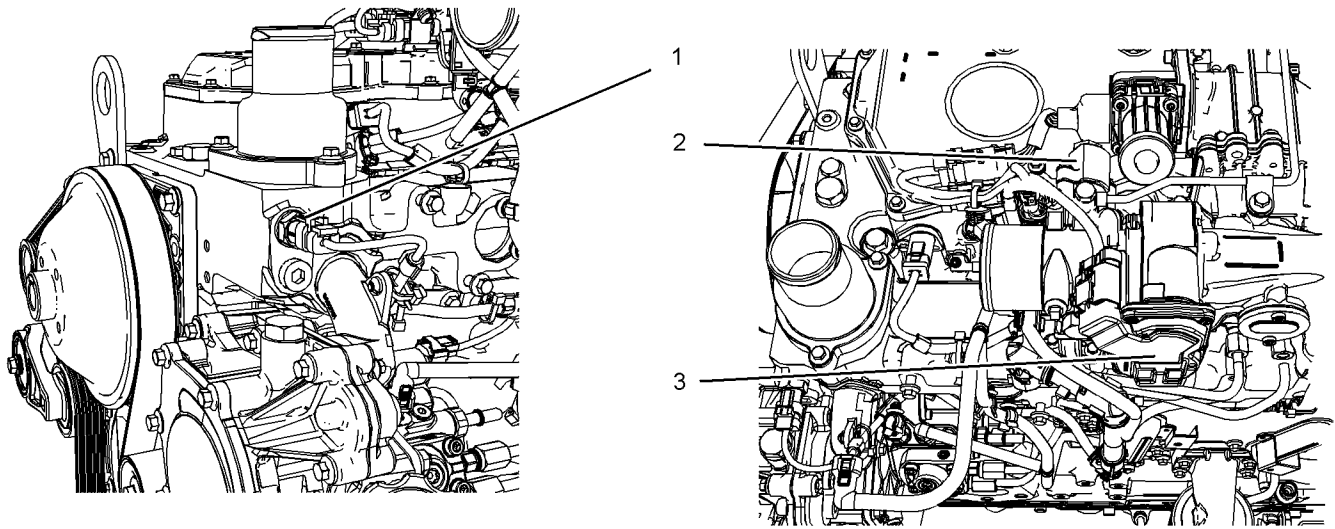

Illustration 31

g02394156

Typical example

(1) Coolant Temperature Sensor

(2) Wastegate Regulator

(3) Throttle valve

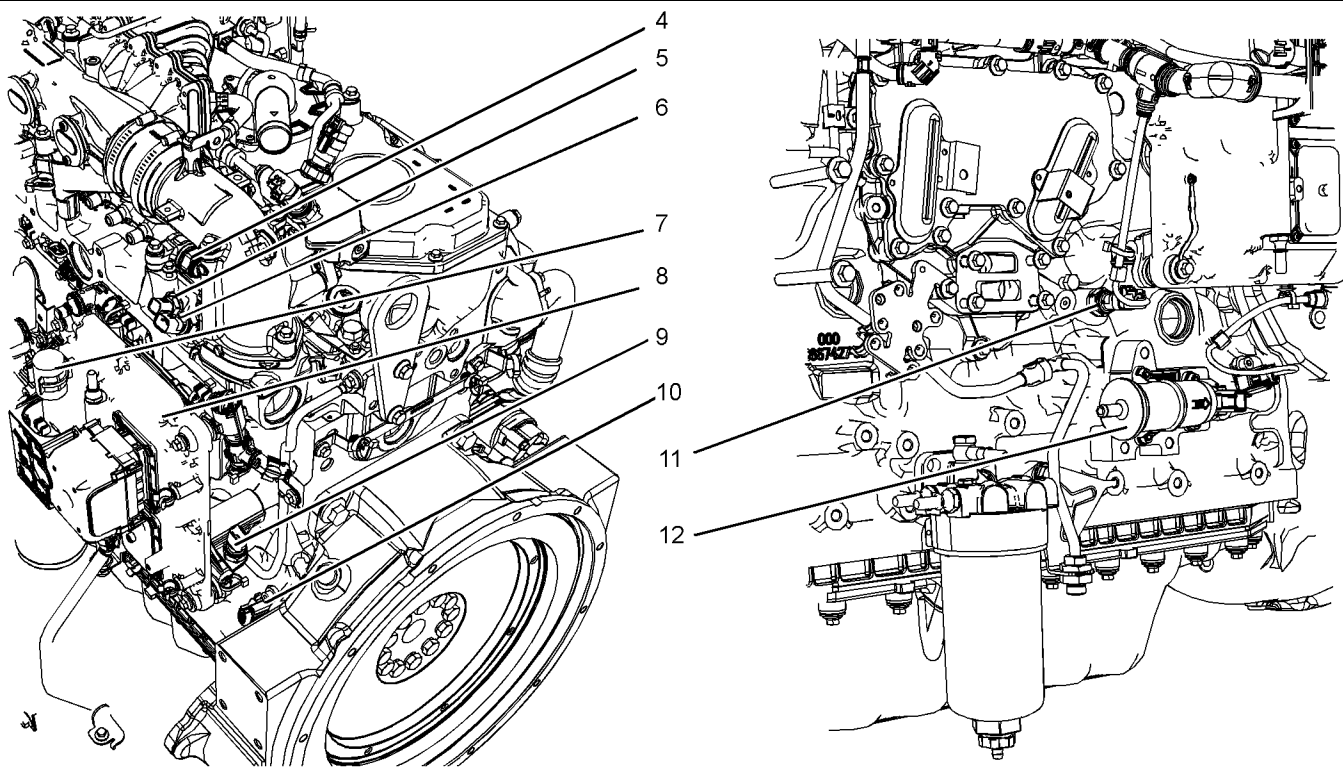

Illustration 32

g02394157

Typical example

(4) Fuel Pressure Sensor (Fuel Rail Pressure Sensor)

(5) Intake Manifold Air Temperature Sensor

(6) Intake Manifold Pressure Sensor

(7) Diagnostic Connector

(8) Electronic Control Module (ECM)

(9) Atmospheric Pressure Sensor (Barometric Pressure Sensor)

(10) Primary Speed/Timing Sensor

(11) Oil Pressure Sensor

(12) Fuel Priming Pump

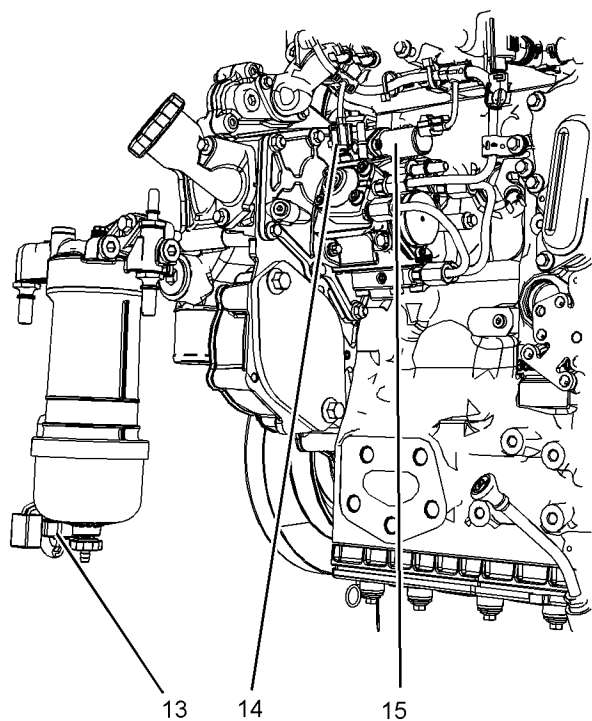

Illustration 33

g02395396

Typical example

- (13) Water in Fuel Switch
- (14) Fuel Temperature Sensor
- (15) Solenoid for the High Pressure Fuel Pump

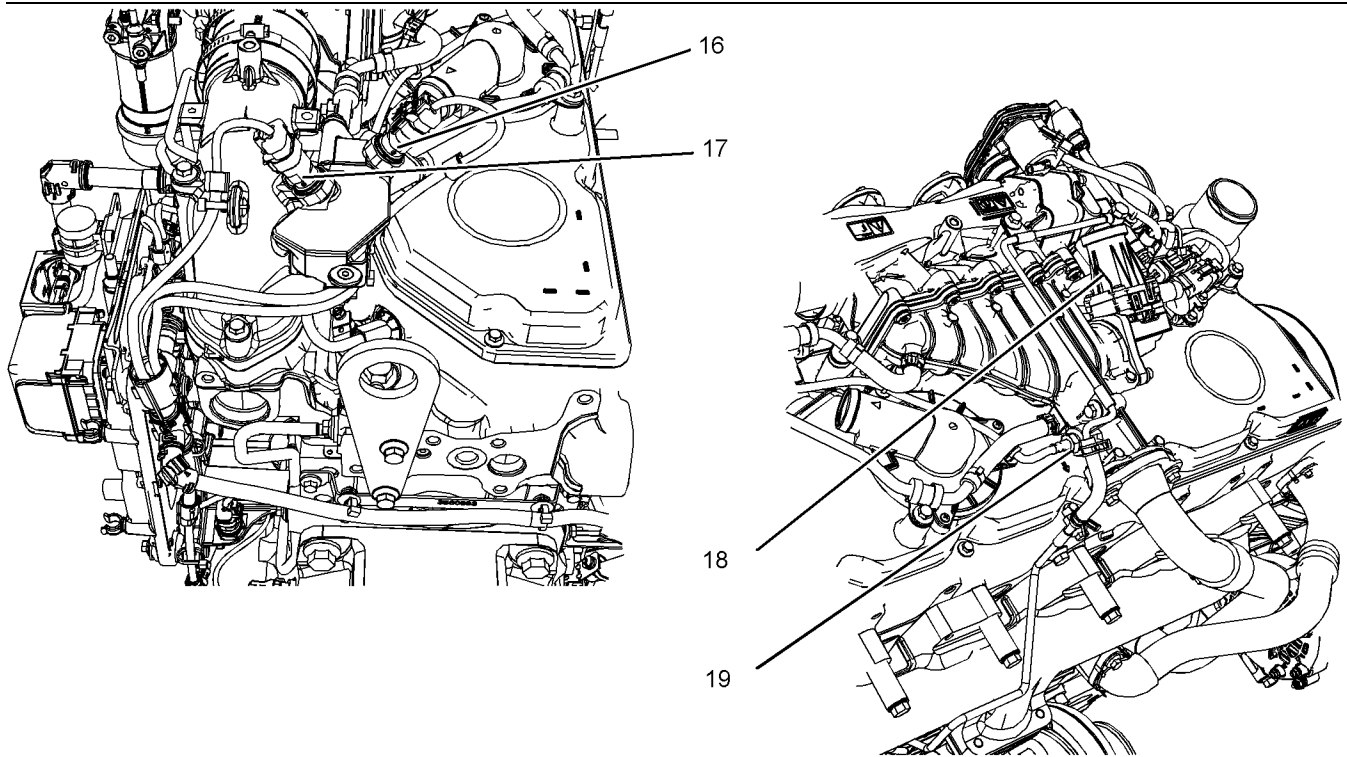

Illustration 34

g02395399

Typical example

(16) Inlet Pressure Sensor for the NOx
Reduction System (NRS)

(17) Outlet Pressure sensor for the NRS
(18) Control Valve for the NRS

(19) Temperature Sensor for the NRS

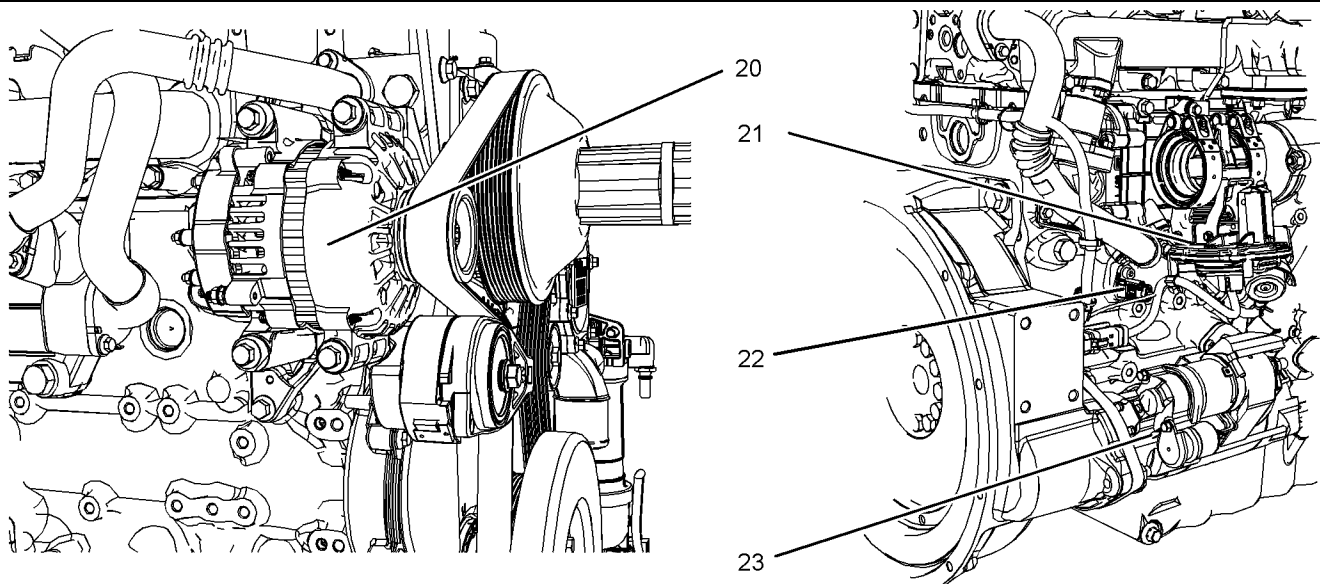

Illustration 35

g02395417

Typical example

(20) Alternator
(21) Back Pressure Valve

(22) Secondary Speed/Timing Sensor
(23) Starter Motor

i04372685

Engine Shutoffs and Engine Alarms

Shutoffs

The shutoffs are electrically operated or mechanically operated. The electrically operated shutoffs are controlled by the ECM.

Shutoffs are set at critical levels for the following items:

- Operating temperature
- Operating pressure
- Operating level
- Operating rpm

The particular shutoff may need to be reset before the engine will start.

NOTICE

Always determine the cause of the engine shutdown. Make necessary repairs before attempting to restart the engine.

Be familiar with the following items:

- Types and locations of the shutoff
- Conditions which cause each shutoff to function
- The resetting procedure that is required to restart the engine

Alarms

The alarms are electrically operated. The operation of the alarms is controlled by the ECM.

The alarm is operated by a sensor or by a switch. When the sensor or the switch is activated, a signal is sent to the ECM. An event code is created by the ECM. The ECM will send a signal in order to illuminate the lamp.

Your engine may be equipped with the following sensors or switches:

Coolant level – The low coolant level switch indicates when the coolant level is low.

Coolant temperature – The coolant temperature sensor indicates high jacket water coolant temperature.

Intake manifold air temperature – The intake manifold air temperature sensor indicates high intake air temperature.

Intake manifold pressure – The intake manifold pressure sensor checks the rated pressure in the engine manifold.

Fuel rail pressure – The fuel rail pressure sensor checks for high pressure or low pressure in the fuel rail.

Engine oil pressure – The engine oil pressure sensor indicates when oil pressure drops below rated system pressure, at a set engine speed.

Engine overspeed – If the engine rpm exceeds the overspeed setting, the alarm will be activated.

Air filter restriction – The switch checks the air filter when the engine is operating.

User-Defined switch – This switch can shut down the engine remotely.

Water in fuel switch – This switch checks for water in the primary fuel filter when the engine is operating.

Fuel temperature – The fuel temperature sensor monitors the pressurized fuel in the high-pressure fuel pump.

Note: The sensing element of the coolant temperature switch must be submerged in coolant in order to operate.

Engines may be equipped with alarms in order to alert the operator when undesirable operating conditions occur.

NOTICE

When an alarm is activated, corrective measures must be taken before the situation becomes an emergency in order to avoid possible engine damage.

If corrective measures are not taken within a reasonable time, engine damage could result. The alarm will continue until the condition is corrected. The alarm may need to be reset.

Testing

Turning the keyswitch to the ON position will check the indicator lights on the control panel. All the indicator lights will be illuminated for 2 seconds after the keyswitch is operated. Replace suspect bulbs immediately.

Refer to Troubleshooting, KENR9116 for more information.

i03554501

Overspeed

- ECM _____ Electronic Control Module
- RPM _____ Revolutions Per Minute

An overspeed is detected by the speed/timing sensors.

The default setting for an overspeed is 3000 rpm. The ECM will cut the power to the electronic unit injectors, until the rpm drops below 200 rpm of the overspeed setting. A diagnostic fault code will be logged into the ECM memory and a warning lamp will indicate a diagnostic fault code.

An overspeed can be set from 2600 rpm to 3000 rpm. This setting depends on the application.

Engine Diagnostics

i04215570

Self-Diagnostics

i02651093

Perkins electronic engines have the capability to perform a self-diagnostics test. When the system detects an active problem, a diagnostic lamp is activated. Diagnostic codes will be stored in permanent memory in the Electronic Control Module (ECM). The diagnostic codes can be retrieved by using the electronic service tool. Refer to Troubleshooting , “Electronic Service Tools” for further information.

Some installations have electronic displays that provide direct readouts of the engine diagnostic codes. Refer to the manual that is provided by the OEM for more information on retrieving engine diagnostic codes. Alternatively refer to Troubleshooting , “Indicator Lamps” for further information.

Active codes represent problems that currently exist. These problems should be investigated first.

Logged codes represent the following items:

- Intermittent problems
- Recorded events
- Performance history

The problems may have been repaired since the logging of the code. These codes do not indicate that a repair is needed. The codes are guides or signals when a situation exists. Codes may be helpful to troubleshoot problems.

When the problems have been corrected, the corresponding logged fault codes should be cleared.

i02651107

Diagnostic Lamp

A diagnostic lamp is used to indicate the existence of an active fault. Refer to Troubleshooting , “Indicator Lamps” for more information. A fault diagnostic code will remain active until the problem is repaired. The diagnostic code may be retrieved by using the electronic service tool. Refer to Troubleshooting , “Electronic Service Tools” for more information.

Diagnostic Flash Code Retrieval

Use the “DIAGNOSTIC” lamp or an electronic service tool to determine the diagnostic flash code.

Use the following procedure to retrieve the flash codes if the engine is equipped with a “DIAGNOSTIC” lamp:

1. Move the keyswitch from the on/off two times within 3 seconds.

A flashing YELLOW lamp indicates a 3-digit code for the engine. The sequence of flashes represents the system diagnostic message. Count the first sequence of flashes in order to determine the first digit of the flash code. After a two second pause, the second sequence of flashes will identify the second digit of the flash code. After the second pause, the third sequence of flashes will identify the flash code.

Table 3

Flash Code Table	
Description	Flash Code
Injector fault	111
Injector number 2 current out of range	112
Injector number 3 current out of range	113
Injector number 4 current out of range	114
Injector number 5 current out of range (6 cylinder only)	115
Injector number 6 current out of range (6 cylinder only)	116
Intake manifold air temperature sensor out of range	133
Engine speed sensor out of range	141
Engine timing offset fault	143
Engine operation mode selector switch erratic, intermittent, or incorrect	144
High air filter restriction - Warning	151
Atmospheric pressure sensor out of range	152
Throttle position sensor out of range	154
Secondary throttle position sensor out of range	155
Oil pressure sensor out of range	157
Fuel rail pressure sensor out of range	159

(continued)

Operation Section
Fault Logging

(Table 3, contd)

Fuel temperature sensor out of range	165
Engine coolant temperature sensor out of range	168
Low Engine Coolant Level - Shutdown	169
Turbo wastegate drive out of range	177
Intake manifold pressure sensor out of range	197
Glow plug start aid relay current above normal	199
Diesel Particulate Filter DPF Intake temperature sensor out of range	224
DPF Soot sensors out of range	226
Exhaust gas recirculation temperature/pressure out of range	227
Exhaust gas recirculation valve control current out of range	228
Exhaust gas recirculation valve control voltage out of range	229
Exhaust gas recirculation pressure sensor out of range	231
Air inlet temperature sensor voltage out of range	232
Ether injection control solenoid out of range	233
Idle validation switch #1 erratic, intermittent, or incorrect	245
Idle validation switch #2 erratic, intermittent, or incorrect	246
Exhaust Gas Recirculation Outlet Pressure Sensor out of range	247
Exhaust back pressure regulator position voltage out of range	249
Engine Fuel Supply Lift Pump Relay out of range	253
Personality module erratic, intermittent, or incorrect	415
Machine security system module abnormal update rate	426
Ignition key switch loss of signal	429
Electrical System Voltage fault	511
SAE J1939 Data Link abnormal update rate	514
5 Volt sensor DC power supply voltage out of range	516
8 V DC Supply voltage out of range	517

(Table 3, contd)

Programmed parameter fault erratic, intermittent, or incorrect	527
5 Volt Sensor DC Power Supply #2 out of range	528
No diagnostic code detected	551

Refer to Troubleshooting, "Diagnostic Flash Code Cross Reference" for more information.

i01902949

Fault Logging

The system provides the capability of Fault Logging. When the Electronic Control Module (ECM) generates an active diagnostic code, the code will be logged in the memory of the ECM. The codes that have been logged by the ECM can be identified by the electronic service tool. The active codes that have been logged will be cleared when the fault has been rectified or the fault is no longer active. The following logged faults can not be cleared from the memory of the ECM without using a factory password: Overspeed, low engine oil pressure and high engine coolant temperature.

i03554534

Engine Operation with Active Diagnostic Codes

If a diagnostic lamp illuminates during normal engine operation, the system has identified a situation that is not within the specification. Use electronic service tools to check the active diagnostic codes.

Note: If the customer has selected "DERATE" and if there is a low oil pressure condition, the Electronic Control Module (ECM) will limit the engine power until the problem is corrected. If the oil pressure is within the normal range, the engine may be operated at the rated speed and load. However, maintenance should be performed as soon as possible.

The active diagnostic code should be investigated. The cause of the problem should be corrected as soon as possible. If the cause of the active diagnostic code is repaired and there is only one active diagnostic code, the diagnostic lamp will turn off.

(continued)

Operation of the engine and performance of the engine can be limited as a result of the active diagnostic code that is generated. Acceleration rates may be significantly slower. Refer to the Troubleshooting Guide for more information on the relationship between these active diagnostic codes and engine performance.

i01902995

Engine Operation with Intermittent Diagnostic Codes

If a diagnostic lamp illuminates during normal engine operation and the diagnostic lamp shuts off, an intermittent fault may have occurred. If a fault has occurred, the fault will be logged into the memory of the Electronic Control Module (ECM).

In most cases, it is not necessary to stop the engine because of an intermittent code. However, the operator should retrieve the logged fault codes and the operator should reference the appropriate information in order to identify the nature of the event. The operator should log any observation that could have caused the lamp to light.

- Low power
- Limits of the engine speed
- Excessive smoke, etc

This information can be useful to help troubleshoot the situation. The information can also be used for future reference. For more information on diagnostic codes, refer to the Troubleshooting Guide for this engine.

i04217251

Configuration Parameters

The engine electronic control module (ECM) has two types of configuration parameters. The system configuration parameters and the customer specified parameters.

The electronic service tool is required in order to alter the configuration parameters.

Table 4

System Configuration Parameters	
Configuration Parameters	Record
Full Load Setting	

(continued)

System Configuration Parameters

System configuration parameters affect the emissions of the engine or the power of the engine. System configuration parameters are programmed at the factory. Normally, system configuration parameters would never require changing through the life of the engine. System configuration parameters must be reprogrammed if an ECM is replaced. System configuration parameters do not require reprogrammed if the ECM software is changed. Factory passwords are required to change these parameters.

Operation Section
Configuration Parameters

(Table 4, contd)

Full Torque Setting	
Rating	
Engine Serial Number	
Factory Installed Aftertreatment Identification Number	
DPF Soot Loading Sensing System Configuration Code	
Limp Home Engine Speed Ramp Rate	
ECM Software Release Date	

Customer Specified Parameters

Customer specified parameters allow the engine to be configured to the exact needs of the application.

The electronic service tool is required in order to alter the customer configuration parameters.

Customer parameters may be changed repeatedly as operational requirements change.

Table 5

Customer Specified Parameters	
Specified Parameters	Record
Low Idle Parameters	
ECM Identification Parameter	
Ether Solenoid Configuration	
PTO and Throttle Lock Parameters	
Throttle Lock Feature Installation Status	
PTO Mode	
Throttle Lock Engine Set Speed 1	
Throttle Lock Engine Set Speed 2	
Throttle Lock Increment Speed Ramp Rate	
Throttle Lock Decrement Speed Ramp Rate	
Throttle Lock Engine Set Speed Increment	
Throttle Lock Engine Set Speed Decrement	
Monitoring Mode Shutdowns	
Monitoring Mode Derates	
Limp Home Desired Engine Speed	
Engine Acceleration Rate	
Engine Speed Decelerating Ramp Rate	
Coolant Level Switch	
Air Filter Restriction Switch Installation Status	
Air Filter Restriction Switch Configuration	

(continued)

(Table 5, contd)

System Operating Voltage Configuration	
Minimum Ambient Air Temperature	
Maximum Ambient Air Temperature	
Shutdown Enable Status	
Shutdown Delay Time	
Ambient Temperature Override Enable Status	
Air Shutoff	
Intermediate Engine Speed	
Engine Fan Control	
Engine Fan Type Configuration	
Pulley Ratio	
Temperature Error Increasing Hysteresis	
Temperature Error Decreasing Hysteresis	
Current Ramp Rate	
Fan Speed	
Top Fan Speed	
Minimum Desired Fan Speed	
Solenoid Minimum Current	
Solenoid Maximum Current	
Solenoid Dither Frequency	
Solenoid Dither Amplitude	
Charge Air Cooler Outlet Temperature Input Enable	
Maximum Air Flow Charge Air Cooler Outlet Temperature	
Minimum Air Flow Charge Air Cooler Outlet Temperature	
Coolant Temperature Input Enable Status	
Maximum Air Flow Coolant Temperature	
Minimum Air Flow Coolant Temperature	
Transmission Oil Temperature Input Enable Status	
Maximum Air Flow Transmission Oil Temperature	
Minimum Air Flow Transmission Oil Temperature	
Hydraulic Oil Temperature Input Enable Status	
Maximum Air Flow Hydraulic Oil Temperature	
Minimum Air Flow Hydraulic Oil Temperature	
Auxiliary #1 Temperature Input Enable Status	
Maximum Air Flow Auxiliary #1 Temperature	
Minimum Air Flow Auxiliary #1 Temperature	

(continued)

Operation Section
Configuration Parameters

(Table 5, contd)

Auxiliary #2 Temperature Input Enable Status	
Maximum Air Flow Auxiliary #2 Temperature	
Minimum Air Flow Auxiliary #2 Temperature	
Reversing Feature	
Reverse Operation Early Termination Enable Status	
Manual Purge	
Suspend Purge	
Purge Cycle Interval	
Purge Cycle Duration	
Coolant Level Switch	
Air Filter Restriction Switch Installation Status	
Air Filter Restriction Switch Configuration	
Water in Fuel Switch Installation Status	
User Defined Switch Installation Status	
Auxiliary Temperature Sensor Installation Status	
Auxiliary Pressure Sensor Installation Status	
Diesel Particulate Filter Regeneration Force/Inhibit Switch Installation	
Remote Torque Speed Control Enable Status	
System Operating Voltage Configuration	
Customer Password 1	
Customer Password 2	
CAN Communication Protocol Write Security	
CAN Communication Protocol Read Security	

Engine Starting

i08165241

i03648917

Before Starting Engine

Perform the required daily maintenance and other periodic maintenance before the engine is started. Inspect the engine compartment. This inspection can help prevent major repairs at a later date. Refer to the Operation and Maintenance Manual, "Maintenance Interval Schedule" for more information.

- Ensure that the engine has an adequate fuel supply.
- Open the fuel supply valve (if equipped).

NOTICE

All valves in the fuel return line must be open and fuel supply lines must be open. Damage to the fuel system can occur if fuel lines are closed with the engine in operation.

If the engine has not been started for several weeks, fuel may have drained from the fuel system. Air may have entered the filter housing. Also, when fuel filters have been changed, some air pockets will be trapped in the engine. In these instances, prime the fuel system. Refer to the Operation and Maintenance Manual, "Fuel System - Prime" for more information on priming the fuel system. Also, check that the fuel specification is correct and that the fuel condition is correct. Refer to the Operation and Maintenance Manual, "Fuel Recommendations".

WARNING

Engine exhaust contains products of combustion which may be harmful to your health. Always start and operate the engine in a well ventilated area and, if in an enclosed area, vent the exhaust to the outside.

- Do not start the engine or move any of the controls if there is a "DO NOT OPERATE" warning tag or similar warning tag attached to the start switch or to the controls.
- Reset all of the shutoffs or alarm components.
- Ensure that any driven equipment has been disengaged. Minimize electrical loads or remove any electrical loads.

Starting the Engine

Note: Do not adjust the engine speed control during start-up. The electronic control module (ECM) will control the engine speed during start-up.

Starting the Engine

1. Disengage any equipment that is driven by the engine.
2. Turn the keyswitch to the RUN position. Leave the keyswitch in the RUN position until the warning light for the glow plugs is extinguished.

Note: If the keyswitch has been left in the RUN position for a long period of time without engaging the electric starting motor, turn the keyswitch from the RUN position to the OFF position and then back to the RUN position to reactivate the glow plug preheat stage.

Note: During the key on, the indicator lamps will be illuminated for 2 seconds to check lamp operation. If any of the lamps do not illuminate, check the bulb. If any indicator lamps stay illuminated or flash, refer to Troubleshooting, "Indicator Lamp Circuit - Test".

3. When the warning light for the glow plugs is extinguished, turn the keyswitch to the START position to engage the electric starting motor and crank the engine.

Note: The operating period of the warning light for the glow plugs will change due to the temperature of the engine.

NOTICE

Do not engage the starting motor when flywheel is turning. Do not start the engine under load.

If the engine fails to start within 30 seconds, release the starter switch or button and wait two minutes to allow the starting motor to cool before attempting to start the engine again.

4. Allow the keyswitch to return to the RUN position after the engine starts.
5. Repeat step 2 through step 4 if the engine fails to start.

6. After starting, the engine may be held at low speed for a duration between 1 and 60 seconds to allow engine systems to stabilize. The duration will depend on ambient temperature, time since last run and other factors. The glow plug warning light will flash to indicate that the engine is being held at low speed in some applications.

i07677844

Cold Weather Starting

WARNING

Do not use aerosol types of starting aids such as ether. Such use could result in an explosion and personal injury.

The ability to start the engine will be improved at temperatures below -18°C (0°F) by the use of a jacket water heater or a battery with extra capacity.

The following items provide a means of minimizing starting problems and fuel problems in cold weather: Engine oil pan heaters, jacket water heaters, fuel heaters, and fuel line insulation.

Use the procedure that follows for cold weather starting.

Note: Do not adjust the engine speed control during start-up. The electronic control module (ECM) will control the engine speed during start-up.

1. Disengage any driven equipment.

Note: During key-ON, the indicator lamps will be illuminated for 2 seconds to check the lamp operation. If any of the indicator lamps do not illuminate check the bulb. If any indicator lamps stay illuminated or flash, refer to Troubleshooting, "Indicator Lamp Circuit - Test".

2. Turn the keyswitch to the RUN position. Leave the keyswitch in the RUN position until the warning light for the glow plugs is extinguished.
3. When the warning light for the glow plugs is extinguished cycle the keyswitch. Turn the keyswitch to the OFF position and then to the START position to engage the electric starting motor and crank the engine.

Note: The operating period of the warning light for the glow plugs will vary according to the ambient air temperature.

NOTICE

Do not engage the starting motor when flywheel is turning. Do not start the engine under load.

If the engine fails to start within 30 seconds, release the starter switch or button and wait two minutes to allow the starting motor to cool before attempting to start the engine again.

4. Allow the keyswitch to return to the RUN position after the engine starts.
5. Repeat step 2 through step 4 if the engine fails to start.

Note: After starting, the engine may be held at low speed for a duration of between 1 and 25 seconds to allow engine systems to stabilize. The duration will depend on ambient temperature, time since last run and other factors. The glow plug warning lamp will flash to indicate that the engine is being held at low speed.

6. The engine should not be raced to speed up the engine warming up process. Allow the engine to idle for 3 to 5 minutes, or allow the engine to idle until the water temperature indicator begins to rise. When idling after the engine has started in cold weather, increase the engine rpm from 1000 to 1200 rpm. This operation will warm up the engine more quickly.
7. Operate the engine at low load until all systems reach operating temperature. Check the gauges during the engine warming up period.

Following a cold start white smoke can be seen from the tailpipe. This smoke is normal and caused by condensation leaving the exhaust system after warming up. The white smoke should clear following working of the engine.

i08717341

Starting with Jump Start Cables

(Do Not Use This Procedure in Hazardous Locations that have Explosive Atmospheres)

WARNING

The connection of battery cables to a battery and the disconnection of battery cables from a battery may cause an explosion which may result in injury or death. The connection and the disconnection of other electrical equipment may also cause an explosion which may result in injury or death. The procedures for the connection and the disconnection of battery cables and other electrical equipment should only be performed in a nonexplosive atmosphere.

WARNING

Improper jump start cable connections can cause an explosion resulting in personal injury.

Prevent sparks near the batteries. Sparks could cause vapors to explode. Do not allow jump start cable ends to contact each other or the engine.

Note: If possible, first diagnose the reason for the starting failure. Refer to Troubleshooting, “Engine Will Not Crank and Engine Cranks But Will Not Start” for further information. Make any necessary repairs. If the engine will not start only due to the condition of the battery, either charge the battery, or start the engine by using another battery with jump-start cables. The condition of the battery can be rechecked after the engine has been switched OFF.

NOTICE

Never attempt to start an engine from an external power source such as electric welding equipment, which has a voltage that is unsuitable for engine starting and will damage the electrical system.

NOTICE

Using a battery source with the same voltage as the electric starting motor. Use ONLY equal voltage for jump starting. The use of higher voltage will damage the electrical system.

Do not reverse the battery cables. The alternator can be damaged. Attach ground cable last and remove first.

Turn all electrical accessories OFF before attaching the jump start cables.

Ensure that the main power switch is in the OFF position before attaching the jump start cables to the engine being started.

1. Turn the start switch on the stalled engine to the OFF position. Turn off all the engines accessories.
 2. Connect one positive end of the jump-start cable to the positive cable terminal of the discharged battery. Connect the other positive end of the jump-start cable to the positive cable terminal of the electrical source.
 3. Connect one negative end of the jump-start cable to the negative cable terminal of the electrical source. Connect the other negative end of the jump-start cable to the engine block or to the chassis ground. This procedure helps to prevent potential sparks from igniting the combustible gases that are produced by some batteries.
- Note:** The engine ECM must be powered before the starting motor is operated or damage can occur.
4. Start the engine in the normal operating procedure. Refer to this Operation and Maintenance Manual, “Starting the Engine”.
 5. Immediately after the engine is started, disconnect the jump-start cables in reverse order.

After jump starting, the alternator may not be able to recharge fully batteries that are severely discharged. The batteries must be replaced or charged to the proper voltage with a battery charger after the engine is stopped. Many batteries which are considered unusable are still rechargeable. Refer to Operation and Maintenance Manual, “Battery - Replace” and Testing and Adjusting Manual, “Battery - Test”.

i02330138

After Starting Engine

Note: In ambient temperatures from 0 to 60°C (32 to 140°F), the warm-up time is approximately three minutes. In temperatures below 0°C (32°F), additional warm-up time may be required.

When the engine idles during warm-up, observe the following conditions:

Do not check the high pressure fuel lines with the engine or the starting motor in operation. If you inspect the engine in operation, always use the proper inspection procedure in order to avoid a fluid penetration hazard. Refer to Operation and Maintenance Manual, “General hazard Information”.

- Check for any fluid or for any air leaks at idle rpm and at one-half full rpm (no load on the engine) before operating the engine under load. This is not possible in some applications.
- Allow the engine to idle for three to five minutes, or allow the engine to idle until the water temperature indicator begins to rise. Check all gauges during the warm-up period.

Note: Gauge readings should be observed and the data should be recorded frequently while the engine is operating. Comparing the data over time will help to determine normal readings for each gauge. Comparing data over time will also help detect abnormal operating developments. Significant changes in the readings should be investigated.

i07671688

After Starting Engine

After starting, the engine may be held at low speed for a duration between 1 and 25 seconds to allow engine systems to stabilize. Holding the engine speed low is controlled by the Electronic Control Module (ECM). The duration will depend on ambient temperature, time since last run and other factors.

Note: In ambient temperatures from 0°C to 60°C (32°F to 140°F), the warm-up time is approximately 3 minutes. In temperatures below 0°C (32°F), additional warm-up time may be required.

When the engine idles during warm-up, observe the following conditions:

Do not check the high-pressure fuel lines with the engine or the starting motor in operation. If you inspect the engine in operation, always use the correct inspection procedure to avoid a fluid penetration hazard. Refer to Operation and Maintenance Manual, “General hazard Information”.

- Check for any fluid or for any air leaks at idle rpm and at one-half full rpm (no load on the engine) before operating the engine under load. This check may not be possible in some applications.
- Allow the engine to idle for 3 to 5 minutes, or allow the engine to idle until the water temperature indicator begins to rise. Check all gauges during the warm-up period.

Constant speed engines should be allowed to operate at low idle for 3 minutes before used at operational speed. If the low idle option is not available, then operate the engine at operational speed with no load for 2 minutes.

Note: Gauge readings should be observed and the data should be recorded frequently while the engine is operating. Comparing the data over time will help to determine normal readings for each gauge. Comparing data over time will also help detect abnormal operating developments. Significant changes in the readings should be investigated.

Engine Operation

i05643897

Engine Operation

Proper operation and maintenance are key factors in obtaining the maximum life and economy of the engine. If the directions in the Operation and Maintenance Manual are followed, costs can be minimized and engine service life can be maximized.

The time that is needed for the engine to reach normal operating temperature can be less than the time taken for a walk-around inspection.

The engine can be operated at the rated rpm after the engine is started and after the engine reaches operating temperature. The engine will reach normal operating temperature sooner during a low engine speed (rpm) and during a low-power demand. This procedure is more effective than idling the engine at no load. The engine should reach operating temperature in a few minutes.

Avoid excess idling. Excessive idling causes carbon buildup, engine slobber and soot loading of the Diesel Particulate Filter (DPF). These issues are harmful to the engine.

Gauge readings should be observed and the data should be recorded frequently while the engine is operating. Comparing the data over time will help to determine normal readings for each gauge. Comparing data over time will also help detect abnormal operating developments. Significant changes in the readings should be investigated.

Reduction of Particulate Emissions

The Diesel Particulate Filter (DPF) will reduce particulate emissions. The DPF collects the soot and any ash that is produced by the combustion in the engine. During regeneration, the soot is converted into a gas which is released into the atmosphere. The Ash remains in the DPF.

The temperature of the DPF must be above a particular value in order for regeneration to occur. The exhaust gas provides heat for the regeneration process.

Engine Operation and the DPF

Regeneration is the process that is used by the DPF in order to remove soot from the DPF.

The process of regeneration is fully automatic. The engine electronic control module will decide when to start and when to stop the process. The operation requires no intervention from the operator.

During normal engine operation, the operator of the engine may notice the lack of black smoke from the exhaust system. In some application the operator may notice an increase in engine idle speed during the regeneration process.

i07677865

Fuel Conservation Practices

The efficiency of the engine can affect the fuel economy. Perkins design and technology in manufacturing provides maximum fuel efficiency in all applications. Follow the recommended procedures to attain optimum performance for the life of the engine.

- Avoid spilling fuel.

Fuel expands when it is warmed up. The fuel may overflow from the fuel tank. Inspect fuel lines for leaks. Repair the fuel lines, as needed.

- Be aware of the properties of different fuels. Use only the recommended fuels. Refer to the Operations and Maintenance Manual, "Fuel Recommendations" for further information.

- Avoid unnecessary idling.

Shut off the engine rather than allowing the engine to idle for long periods of time.

- Observe the service indicator frequently. Keep the air cleaner elements clean.
- Ensure that the turbocharger is operating correctly. For more information refer to this Operation and Maintenance Manual, "Turbocharger - Inspect"
- Maintain a good electrical system.

One faulty battery cell will overwork the alternator. This fault will consume excess power and excess fuel.

- The belt should be in good condition. Refer to the Systems Operation, Testing and Adjusting, "V-Belt Test" for further information.
- Ensure that all the connections of the hoses are tight. The connections should not leak.
- Ensure that the driven equipment is in good working order.

Operation Section
Fuel Conservation Practices

- Cold engines consume excess fuel. Utilize heat from the jacket water system and the exhaust system, when possible. Keep cooling system components clean and keep cooling system components in good repair. Never operate the engine without water temperature regulators. All these items will help maintain operating temperatures.

Engine Stopping

i05784249

Stopping the Engine

i06832774

NOTICE

Stopping the engine immediately after it has been working under load, can result in overheating and accelerated wear of the engine components.

Avoid accelerating the engine prior to shutting it down.

Avoiding hot engine shutdowns will maximize turbo-charger shaft and bearing life.

Note: Individual applications will have different control systems. Ensure that the shutoff procedures are understood. Use the following general guidelines to stop the engine.

1. Remove the load from the engine. Reduce the engine speed (rpm) to low idle. Allow the engine to idle for 5 minutes to cool the engine.
2. Stop the engine after the cool down period according to the shutoff system on the engine. Turn the ignition key switch to the OFF position. If necessary, refer to the instructions that are provided by the OEM.

NOTICE

Before any service or repairs are performed, ensure that the power supply to the engine is disconnected.

i07764840

Emergency Stopping

NOTICE

Emergency shutoff controls are for EMERGENCY use ONLY. DO NOT use emergency shutoff devices or controls for normal stopping procedure.

The Original Equipment Manufacturer (OEM) may have equipped the application with an emergency stop button. For more information about the emergency stop button, refer to the OEM information.

Ensure that any components for the external system that support the engine operation are secured after the engine is stopped.

After Stopping Engine

Note: Before you check the engine oil, do not operate the engine for at least 10 minutes. This period will allow the engine oil to return to the oil pan.

WARNING

Contact with high pressure fuel may cause fluid penetration and burn hazards. High pressure fuel spray may cause a fire hazard. Failure to follow these inspection, maintenance and service instructions may cause personal injury or death.

- After the engine has stopped, you must wait for 10 minutes in order to allow the fuel pressure to be purged from the high-pressure fuel lines before any service or repair is performed on the engine fuel lines. The 10 minute wait will also allow static charge to dissipate from the low-pressure fuel system. If necessary, perform minor adjustments. Repair any leaks from the low-pressure fuel system and from the cooling, lubrication, or air systems. Replace any high-pressure fuel line that has leaked. Refer to Disassembly and assembly Manual, "Fuel Injection Lines - Install".
- Check the crankcase oil level. Maintain the oil level between the "MIN" mark and the "MAX" mark on the engine oil level gauge.
- If the engine is equipped with a service hour meter, note the reading. Perform the maintenance that is in the Operation and Maintenance Manual, "Maintenance Interval Schedule".
- Fill the fuel tank, in order to help prevent accumulation of moisture in the fuel. Do not overfill the fuel tank.

NOTICE

Only use antifreeze/coolant mixtures recommended in this Operation and Maintenance Manual, "Refill Capacities and Recommendations" topic or in this Operation and Maintenance Manual, "Fluid Recommendations" topic. Failure to do so can cause engine damage.

 **WARNING**

Pressurized System: Hot coolant can cause serious burns. To open the cooling system filler cap, stop the engine and wait until the cooling system components are cool. Loosen the cooling system pressure cap slowly in order to relieve the pressure.

- Allow the engine to cool. Check the coolant level.
- Check the coolant for correct antifreeze protection and the correct corrosion protection. Add the correct coolant/water mixture, if necessary.
- Perform all required periodic maintenance on all driven equipment. This maintenance is outlined in the instructions from the OEM.

Cold Weather Operation

i07671718

Cold Weather Operation

Perkins Diesel Engines can operate effectively in cold weather. During cold weather, the starting and the operation of the diesel engine depends on the following items:

- The type of fuel that is used
- The viscosity of the engine oil
- The operation of the glow plugs
- Optional Cold starting aid
- Battery condition
- Ambient air temperature and altitude
- Parasitic load of the application
- Application hydraulic and transmission oil viscosities

This section will cover the following information:

- Potential problems that are caused by cold-weather operation
- Suggest steps which can be taken to minimize starting problems and operating problems when the ambient air temperature is between 0° to -40 °C (32° to 40 °F).

The operation and maintenance of an engine in freezing temperatures is complex. This complexity is because of the following conditions:

- Weather conditions
- Engine applications

Recommendations from your Perkins dealer or your Perkins distributor are based on past proven practices. The information that is contained in this section provides guidelines for cold-weather operation.

Hints for Cold-Weather Operation

- After starting the engine, the engine speed will be governed for up to a maximum of 25 seconds. After this period, the engine should be operated at low loads until a minimum operating temperature of 80° C (176° F) is achieved.

- Achieving operating temperature will help prevent the intake valves and exhaust valves from sticking.
- The cooling system and the lubrication system for the engine do not lose heat immediately upon shutdown. This means that an engine can be shut down for a period of time and the retained heat within the engine will allow the engine readily start.
- Install the correct specification of engine lubricant before the beginning of cold weather. Refer to this Operation and Maintenance Manual, "Fluid Recommendations" for the recommended viscosity of oil.
- Check all rubber parts (hoses, fan drive belts) weekly.
- Check all electrical wiring and connections for any fraying or damaged insulation.
- Keep all batteries fully charged and warm by ensuring that the engine is allowed to operate at normal operating temperature.
- Fill the fuel tank at the end of each shift.
- Check the air cleaners and the air intake daily. Check the air intake more often when you operate in snow.
- Ensure that the glow plugs are in working order. Refer to Troubleshooting, "Glow Plug Starting Aid-Test".

WARNING

Personal injury or property damage can result from alcohol or starting fluids.

Alcohol or starting fluids are highly flammable and toxic and if improperly stored could result in injury or property damage.

WARNING

Do not use aerosol types of starting aids such as ether. Such use could result in an explosion and personal injury.

- For jump starting with cables in cold weather, refer to the Operation and Maintenance Manual, "Starting with Jump-Start Cables." for instructions.

Viscosity of the Engine Lubrication Oil

Correct engine oil viscosity is essential. Oil viscosity affects lubrication properties and wear protection that the oil provides for the engine. Refer to this Operation and Maintenance Manual, "Fluid Recommendations" for the recommended viscosity of oil.

At temperatures below -10°C (14°F) damage to engine components can occur if the engine is allowed to operate at high load and speed immediately after starting.

Recommendations for the Coolant

Provide cooling system protection for the lowest expected outside temperature. Refer to this Operation and Maintenance Manual, "Fluid Recommendations" for the recommended coolant mixture.

In cold weather, check the coolant often for the correct glycol concentration to ensure adequate freeze protection.

Engine Block Heaters

Engine block heaters (if equipped) heat the engine jacket water that surrounds the combustion chambers. This heat provides the following functions:

- Startability is improved.
- Warm up time is reduced.

An electric block heater can be activated once the engine is stopped. A block heater can be 110 V dc or 240 V dc. The output can be 750/1000W. Consult your Perkins dealer or your Perkins distributor for more information.

Idling the Engine

After starting the engine, the engine speed will be governed for a maximum period of 25 seconds. When idling after the engine is started in cold weather, increase the engine rpm from 1000 to 1200 rpm. This idling will warm up the engine more quickly. Maintaining an elevated low idle speed for extended periods will be easier with the installation of a hand throttle. The engine should not be "raced" to speed up the warm-up process.

While the engine is idling, the application of a light load (parasitic load) will assist in achieving the minimum operating temperature. The minimum operating temperature is 80°C (176°F).

Recommendations for Coolant Warm Up

Warm up an engine that has cooled below normal operating temperatures due to inactivity. This warm-up should be performed before the engine is returned to full operation. During operation in very cold temperature conditions, damage to engine valve mechanisms can result from engine operation for short intervals. This damage can happen if the engine is started and the engine is stopped many times without being operated to warm up completely.

When the engine is operated below normal operating temperatures, fuel and oil are not burned completely in the combustion chamber. This fuel and oil causes soft carbon deposits to form on the valve stems. Generally, the deposits do not cause problems and the deposits are burned off during operation at normal engine operating temperatures.

When starting and stopping an engine many times without being operated to warm up completely, the carbon deposits become thicker. This starting and stopping can cause the following problems:

- Free operation of the valves is prevented.
- Valves become stuck.
- Pushrods may become bent.
- Other damage to valve train components can result.

For these reasons, when the engine is started, the engine must be operated until the coolant temperature is 80°C (176°F) minimum. Carbon deposits on the valve stems will be kept at a minimum. The free operation of the valves and the valve components will be maintained.

The engine must be warmed thoroughly to keep other engine parts in better condition. The service life of the engine will be generally extended. Lubrication will be improved. There will be less acid and less sludge in the oil. This condition will provide longer service life for the engine bearings, the piston rings, and other parts. However, limit unnecessary idle time to 10 minutes to reduce wear and unnecessary fuel consumption.

The Water Temperature Regulator and Insulated Heater Lines

The engine is equipped with a water temperature regulator. When the engine coolant is below the correct operating temperature, jacket water circulates through the engine cylinder block and into the engine cylinder head. The coolant then returns to the cylinder block via an internal passage that bypasses the valve of the coolant temperature regulator. This return ensures that coolant flows around the engine under cold operating conditions. The water temperature regulator begins to open when the engine jacket water has reached the correct minimum operating temperature. As the jacket water coolant temperature rises above the minimum operating temperature, the water temperature regulator opens further allowing more coolant through the radiator to dissipate excess heat.

The progressive opening of the water temperature regulator operates the progressive closing of the bypass passage between the cylinder block and head. This action ensures maximum coolant flow to the radiator to achieve maximum heat dissipation.

Note: Do not restrict the air flow. Restriction of the air flow can damage the fuel system. Perkins discourages the use of all air flow restriction devices such as radiator shutters. Restriction of the air flow can result in the following: high exhaust temperatures, power loss, excessive fan usage, and reduction in fuel economy.

A cab heater is beneficial in very cold weather. The feed from the engine and the return lines from the cab should be insulated to reduce heat loss to the outside air.

Recommendation for Crankcase Breather Protection

Crankcase ventilation gases contain a large quantity of water vapor. This water vapor can freeze in cold ambient conditions and can plug or damage the crankcase ventilation system. If the engine is operated in temperatures below -25°C (-13°F), measures must be taken to prevent freezing and plugging of the breather system. Insulated hoses and a heated canister assembly should be installed.

Consult with your Perkins dealer or your Perkins distributor for the recommended breather components for operation from -25° to -40°C (-13° to -72°F).

i07818744

Fuel and the Effect from Cold Weather

Note: Only use grades of fuel that are recommended by Perkins. Refer to this Operation and Maintenance Manual, "Fluid Recommendations".

Properties of the diesel fuel can have a significant effect on the engine cold start capability. It is critical that the low temperature properties of diesel fuel are acceptable for the minimum ambient temperature the engine is expected to see in operation.

Following properties are used to define fuels low temperature capability:

- Cloud point
- Pour point
- Cold Filter Plugging Point (CFPP)

The cloud point of the fuel is the temperature at which waxes naturally found in the diesel fuel begin to form crystals. The cloud point of the fuel must be below lowest ambient temperature to prevent filters from plugging.

Pour point is the last temperature before the fuel flow stops and waxing of the fuel will start.

Cold Filter Plugging Point (CFPP) is a temperature at which a particular fuel will pass through a standardized filtration device. This CFPP gives an estimate of the lower operability temperature of fuel

Be aware of these properties when diesel fuel is purchased. Consider the average ambient air temperature for the engines application. Engines that are fueled in one climate may not operate well if the engines are shipped to colder climate. Problems can result due to changes in temperature.

Before troubleshooting for low power or for poor performance in the winter, check the fuel for waxing

The following components can provide a means of minimizing fuel waxing problems in cold weather:

- Fuel heaters, which may be an OEM option
- Fuel line insulation, which may be an OEM option

Winter and arctic grades of diesel fuel are available in the countries and territories with severe winters. For more information refer to the Operation and Maintenance Manual, "Fuel For Cold-Weather Operation"

Another important fuel property which can affect cold start and operation of diesel engine is Cetane number. Detail and requirements of this property are given in this Operation and Maintenance Manual, "Fluid Recommendations".

For more information about fuel heaters (if equipped), refer to the OEM information.

i05359588

Fuel Related Components in Cold Weather

Fuel Tanks

Condensation can form in partially filled fuel tanks. Top off the fuel tanks after you operate the engine.

Fuel tanks should contain some provision for draining water and sediment from the bottom of the tanks.

Some fuel tanks use supply pipes that allow water and sediment to settle below the end of the fuel supply pipe.

Some fuel tanks use supply lines that take fuel directly from the bottom of the tank. If the engine is equipped with this system, regular maintenance of the fuel system filter is important.

Drain the water and sediment from any fuel storage tank at the following intervals: weekly, service intervals and refueling of the fuel tank. Draining will help prevent water and/or sediment from being pumped from the fuel storage tank and into the engine fuel tank.

Fuel Filters

After you change the fuel filter, always prime the fuel system in order to remove air bubbles from the fuel system. Refer to the Operation and Maintenance Manual in the Maintenance Section for more information on priming the fuel system.

The micron rating and the location of a primary fuel filter is important in cold-weather operation. The In-line filter, primary fuel filter, and the fuel supply line are the most common components that are affected by cold fuel.

Fuel Heaters

Note: The OEM may equip the application with fuel heaters. If so, the temperature of the fuel must not exceed 73 °C (163 °F) at the fuel transfer pump. The fuel heater should be installed before the electric lift pump.

Maintenance Section

Refill Capacities

i03995972

Refill Capacities

Lubrication System

The refill capacities for the engine crankcase reflect the approximate capacity of the crankcase or sump plus standard oil filters. Auxiliary oil filter systems will require additional oil. Refer to the OEM specifications for the capacity of the auxiliary oil filter. Refer to the Operation and Maintenance Manual, "Maintenance Section" for more information on Lubricant Specifications.

Table 6

Engine Refill Capacities		
Compartment or System	Minimum	Maximum
Crankcase Oil Sump ⁽¹⁾	13.5 L (3.56 US gal)	16.5 L (4.36 US gal)

⁽¹⁾ These values are the approximate capacities for the crankcase oil sump (aluminum) which includes the standard factory installed oil filters. Engines with auxiliary oil filters will require additional oil. Refer to the OEM specifications for the capacity of the auxiliary oil filter. The design of the oil pan can change the oil capacity of the oil pan.

Cooling System

Refer to the OEM specifications for the External System capacity. This capacity information will be needed in order to determine the amount of coolant/antifreeze that is required for the Total Cooling System.

Table 7

Engine Refill Capacities	
Compartment or System	Liters
Engine Only	15 L (3.96 US gal)
External System Per OEM ⁽¹⁾	

(continued)

(Table 7, contd)

⁽¹⁾ The External System includes a radiator or an expansion tank with the following components: heat exchanger and piping. Refer to the OEM specifications. Enter the value for the capacity of the External System in this row.

i07675883

Fluid Recommendations

General Coolant Information

NOTICE

Never add coolant to an overheated engine. Engine damage could result. Allow the engine to cool first.

NOTICE

If the engine is to be stored in, or shipped to an area with below freezing temperatures, the cooling system must be either protected to the lowest outside temperature or drained completely to prevent damage.

NOTICE

Frequently check the specific gravity of the coolant for proper freeze protection or for anti-boil protection.

Clean the cooling system for the following reasons:

- Contamination of the cooling system
- Overheating of the engine
- Foaming of the coolant

NOTICE

Never operate an engine without water temperature regulators in the cooling system. Water temperature regulators help to maintain the engine coolant at the proper operating temperature. Cooling system problems can develop without water temperature regulators.

Many engine failures are related to the cooling system. The following problems are related to cooling system failures: Overheating, leakage of the water pump and plugged radiators or heat exchangers.

These failures can be avoided with correct cooling system maintenance. Cooling system maintenance is as important as maintenance of the fuel system and the lubrication system. Quality of the coolant is as important as the quality of the fuel and the lubricating oil.

Coolant is normally composed of three elements: Water, additives, and glycol.

Water

Water is used in the cooling system to transfer heat.

Note: The water must be used with an inhibitor to protect the engine.

Distilled water or deionized water is recommended for use in engine cooling systems.

DO NOT use the following types of water in cooling systems: Hard water, softened water that has been conditioned with salt and sea water.

If distilled water or deionized water is not available, use water with the properties that are listed in Table 8 .

Table 8

Acceptable Water	
Property	Maximum Limit
Chloride (Cl)	40 mg/L
Sulfate (SO ₄)	100 mg/L
Total Hardness	170 mg/L
Total Solids	340 mg/L
Acidity	pH of 5.5 to 9.0

For a water analysis, consult one of the following sources:

- Local water utility company
- Agricultural agent
- Independent laboratory

Additives

Additives help to protect the metal surfaces of the cooling system. A lack of coolant additives or insufficient amounts of additives enable the following conditions to occur:

- Corrosion
- Formation of mineral deposits
- Rust
- Scale
- Foaming of the coolant

Many additives are depleted during engine operation. These additives must be replaced periodically.

Additives must be added at the correct concentration. Over concentration of additives can cause the inhibitors to drop out-of-solution. The deposits can enable the following problems to occur:

- Formation of gel compounds

- Reduction of heat transfer
- Leakage of the water pump seal
- Plugging of radiators, coolers, and small passages

Glycol

Glycol in the coolant helps to provide protection against the following conditions:

- Boiling
- Freezing
- Cavitation of the water pump

For optimum performance, Perkins recommends a 1:1 mixture of a water/glycol solution.

Note: Use a mixture that will provide protection against the lowest ambient temperature.

Note: 100 percent pure glycol will freeze at a temperature of -13 °C (8.6 °F).

Most conventional antifreezes use ethylene glycol. Propylene glycol may also be used. In a 1:1 mixture with water, ethylene and propylene glycol provide similar protection against freezing and boiling. Refer to Table 9 and refer to table 10 .

Table 9

Ethylene Glycol	
Concentration	Freeze Protection
50 Percent	-36 °C (-33 °F)
60 Percent	-51 °C (-60 °F)

NOTICE

Do not use propylene glycol in concentrations that exceed 50 percent glycol because of the reduced heat transfer capability of propylene glycol. Use ethylene glycol in conditions that require additional protection against boiling or freezing.

Table 10

Propylene Glycol	
Concentration	Freeze Protection
50 Percent	-29 °C (-20 °F)

To check the concentration of glycol in the coolant, measure the specific gravity of the coolant.

Note: Some commercially available coolants are based on alternative fluids, such as 1, 3-propanediol (beta-propylene glycol, PDO), glycerin (glycerol) or mixtures of these alternatives with ethylene/propylene glycols. At the time of publication of this document no industry standard exists for coolants based on these chemicals. Until such standard/specifications are published and evaluated by Perkins, use of PDO, glycerine or other alternative coolants is not recommended in Perkins diesel engines.

Coolant Recommendations

- ELC _____ Extended Life Coolant
- SCA _____ Supplement Coolant Additive
- ASTM _____ American Society for Testing and Materials

ELC - extended life coolant. A coolant that relies on organic inhibitors for corrosion and cavitation protection. Also called OAT coolant (Organic Acid Technology).

SCA - supplemental coolant additive, concentrated inorganic inhibitor package.

Extender - concentrated organic inhibitor package.

Conventional Coolant - a coolant that relies on inorganic inhibitors for corrosion and cavitation protection.

Hybrid Coolant - a coolant in which the corrosion and cavitation protection is based on a mixture of organic and inorganic inhibitors.

The following coolants are recommended for used in Perkins diesel engines:

Preferred – Perkins ELC

Acceptable – A commercial heavy-duty antifreeze that meets “ASTM D6210” or “ASTM D4985” specifications.

NOTICE

The Perkins industrial engines with a NOx reduction system must be operated with a minimum 30% volume glycol-water mixture, Perkins recommends 50% volume glycol-water mixture of water and glycol. The 50% concentration allows the NOx reduction system to operate correctly at high ambient temperatures.

NOTICE

Do not use a commercial coolant/antifreeze that only meets the ASTM D3306 specification. This type of coolant/antifreeze is made for light automotive applications.

Perkins recommends a 50% mixture of water and glycol. This mixture of water and glycol will provide optimum heavy-duty performance as an antifreeze. This ratio may be changed to 40% water to 60% glycol if extra freezing protection is required.

A mixture of SCA inhibitor and water is acceptable but will not give the same level of corrosion, boiling and, freezing protection as ELC. Perkins recommends a 6 percent to 8 percent concentration of SCA in those cooling systems. Distilled water or deionized water is preferred.

Table 11

Coolant Service Life	
Coolant Type	Service Life ⁽¹⁾
Perkins ELC	6,000 Service Hours or Three Years
Commercial Heavy-Duty Antifreeze that meets “ASTM D6210”	3000 Service Hours or Two Year
Commercial SCA inhibitor and Water	3000 Service Hours or One Year

⁽¹⁾ Use the interval that occurs first. The cooling system must also be flushed out at this time.

Perkins ELC

Perkins provides ELC for use in the following applications:

- Heavy-duty spark ignited gas engines
- Heavy-duty diesel engines
- Automotive applications

The anti-corrosion package for ELC is different from the anti-corrosion package for other coolants. ELC is an ethylene glycol base coolant. However, ELC contains organic corrosion inhibitors and antifoam agents with low amounts of nitrite. Perkins ELC has been formulated with the correct amount of these additives to provide superior corrosion protection for all metals in engine cooling systems.

ELC is available in a premixed cooling solution with distilled water. ELC is a 1:1 mixture. The Premixed ELC provides freeze protection to -36 °C (-33 °F). The Premixed ELC is recommended for the initial fill of the cooling system. The Premixed ELC is also recommended for topping off the cooling system.

Containers of several sizes are available. Consult your Perkins distributor for the part numbers.

ELC Cooling System Maintenance

Correct additions to the Extended Life Coolant

NOTICE

Use only Perkins products for pre-mixed coolants.

Mixing Extended Life Coolant with other products reduces the Extended Life Coolant service life. Failure to follow the recommendations can reduce cooling system components life unless appropriate corrective action is performed.

To maintain the correct balance between the antifreeze and the additives, you must maintain the recommended concentration of ELC. Lowering the proportion of antifreeze lowers the proportion of additive. Lowering the ability of the coolant to protect the system will form pitting, from cavitation, from erosion, and from deposits.

NOTICE

Do not use a conventional coolant to top-off a cooling system that is filled with Extended Life Coolant (ELC).

Do not use supplemental coolant additive (SCA).

ELC Cooling System Cleaning

Note: If the cooling system is already using ELC, cleaning agents are not required to be used at the specified coolant change interval. Cleaning agents are only required if the system has been contaminated by the addition of some other type of coolant or by cooling system damage.

Clean water is the only cleaning agent that is required when ELC is drained from the cooling system.

Before the cooling system is filled, the heater control (if equipped) must be set to the HOT position. Refer to the OEM to set the heater control. After the cooling system is drained and the cooling system is refilled, operate the engine until the coolant level reaches the normal operating temperature and until the coolant level stabilizes. As needed, add the coolant mixture to fill the system to the specified level.

Changing to Perkins ELC

To change from heavy-duty antifreeze to the Perkins ELC, perform the following steps:

NOTICE

Care must be taken to ensure that all fluids are contained during performance of inspection, maintenance, testing, adjusting and the repair of the product. Be prepared to collect the fluid with suitable containers before opening any compartment or disassembling any component containing fluids.

Dispose of all fluids according to local regulations and mandates.

1. Drain the coolant into a suitable container.
2. Dispose of the coolant according to local regulations.
3. Fill the cooling system with a 33 percent solution of Perkins ELC and operate the engine, ensure that the thermostat opens. Stop the engine and allow the engine to cool. Drain the coolant.

Note: Use distilled or deionized water in the solution.

4. Again, fill the cooling system with a 33 percent solution of Perkins ELC and operate the engine ensure that the thermostat opens. Stop the engine and allow to cool.
 5. Drain the cooling system.
-

NOTICE

Incorrect or incomplete flushing of the cooling system can result in damage to copper and other metal components.

NOTICE

Most commercial cooling system cleaning agents are corrosive and their use is not recommended by Perkins.

6. Fill the cooling system with the Perkins Premixed ELC. Operate the engine. Ensure that all coolant valves open then stop the engine. When cool check the coolant level.

ELC Cooling System Contamination

NOTICE

Mixing ELC with other products reduces the effectiveness of the ELC and shortens the ELC service life. Failure to follow these recommendations can result in shortened cooling system component life.

ELC cooling systems can withstand contamination to a maximum of 10 percent of conventional heavy-duty antifreeze or SCA. If the contamination exceeds 10 percent of the total system capacity, perform ONE of the following procedures:

- Drain the cooling system into a suitable container. Dispose of the coolant according to local regulations. Flush the system with a 5 to 10 percent solution of Perkins ELC. Fill the system with the Perkins ELC.
- Maintain the system as a conventional Heavy-Duty Coolant. Treat the system with an SCA. Change the coolant at the interval that is recommended for the conventional Heavy-Duty Coolant.

Commercial Heavy-Duty Antifreeze and SCA

NOTICE

Commercial Heavy-Duty Coolant which contains Amines as part of the corrosion protection system must not be used.

NOTICE

Never operate an engine without water temperature regulators in the cooling system. Water temperature regulators help to maintain the engine coolant at the correct operating temperature. Cooling system problems can develop without water temperature regulators.

Check the glycol concentration to ensure adequate protection against boiling or freezing. Perkins recommends the use of a refractometer for checking the glycol concentration. A hydrometer should not be used.

Perkins engine cooling systems should be tested at 500 hour intervals for the concentration of SCA.

Additions of SCA are based on the results of the test. An SCA that is liquid may be needed at 500 hour intervals.

NOTICE

Do not mix types and brands of coolant.

Do not mix brands and types of SCAs.

Do not mix SCAs and Extenders.

Only use SCAs or Extender approved by coolant manufacturer and compatible with coolant.

Adding the SCA to Heavy-Duty Coolant at the Initial Fill

Coolants conforming to ASTM D4985 and not conforming D6210 require the addition of SCA at initial fill.

Use the equation that is in Table 12 to determine the amount of SCA that is required when the cooling system is initially filled.

Table 12

Equation For Adding The SCA To The Heavy-Duty Coolant At The Initial Fill
$V \times 0.07 = X$
V is the total volume of the cooling system.
X is the amount of SCA that is required.

Table 13 is an example for using the equation that is in Table 12 .

Table 13

Example Of The Equation For Adding The SCA To The Heavy-Duty Coolant At The Initial Fill		
Total Volume of the Cooling System (V)	Multiplication Factor	Amount of SCA that is Required (X)
15 L (4 US gal)	× 0.07	1.05 L (35.5 oz)

Adding The SCA to The Heavy-Duty Coolant For Maintenance

Heavy-duty antifreeze of all types REQUIRE periodic additions of an SCA.

Test the antifreeze periodically for the concentration of SCA. For the interval, refer to the Operation and Maintenance Manual, "Maintenance Interval Schedule" (Maintenance Section). Cooling System Supplemental Coolant Additive (SCA) Test/Add.

Additions of SCA are based on the results of the test. The size of the cooling system determines the amount of SCA that is needed.

Use the equation that is in Table 14 to determine the amount of SCA that is required, if necessary:

Table 14

Equation For Adding The SCA To The Heavy-Duty Coolant For Maintenance
$V \times 0.023 = X$
V is the total volume of the cooling system.
X is the amount of SCA that is required.

Table 15 is an example for using the equation that is in Table 14 .

Table 15

Example Of The Equation For Adding The SCA To The Heavy-Duty Coolant For Maintenance		
Total Volume of the Cooling System (V)	Multiplication Factor	Amount of SCA that is Required (X)
15 L (4 US gal)	× 0.023	0.35 L (11.7 oz)

Cleaning the System of Heavy-Duty Antifreeze

Note: Before corrosion inhibitors can be effective the cooling system must be free from rust, scale and deposits.

- Drain the cooling system.
- Before filling the cooling system with acceptable quality water, pre-dissolve the cleaning agent in the water. Use a non-foaming detergent to clean oil contamination, consult your Perkins dealer for suitable product.

NOTICE

Most commercial cooling system cleaning agents are corrosive and their use is not recommended by Perkins.

The cooling system must be thoroughly flushed with clean water after using cleaning agents.

Cleaning agents for marine or industrial cooling system must not be used, these are very aggressive and can cause damage to cooling system components.

- Run the engine for approximately 30 minutes and then leave the engine to cool down.
- Take a sample of the solution from the cooling system, drain the system.
- Allow the sample to sit for at least 30 minutes and check for signs of oil and deposits. If oil and deposits are still present repeat the procedure.
- Flush the system with clean water.
- Fill the system with new coolant.

i07711004

Fluid Recommendations

General Lubricant Information

Because of government regulations regarding the certification of exhaust emissions from the engine, the lubricant recommendations must be followed.

- API_____American Petroleum Institute
- SAE_____Society Of Automotive Engineers Inc.
- ACEA_____Association des Constructeurs European Automobiles.
- ECF-3_____Engine Crankcase Fluid

Licensing

The Engine Oil Licensing and Certification System by the American Petroleum Institute (API) and the Association des Constructeurs European Automobiles (ACEA) is recognized by Perkins. For detailed information about this system, see the latest edition of the "API publication No. 1509". Engine oils that bear the API symbol are authorized by API.

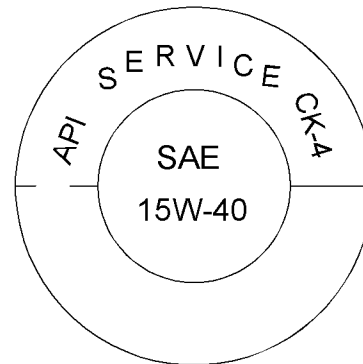

Illustration 36

g06183768

Typical API symbol

Terminology

Certain abbreviations follow the nomenclature of "SAE J754". Some classifications follow "SAE J183" abbreviations, and some classifications follow the "EMA Recommended Guideline on Diesel Engine Oil". In addition to Perkins definitions, there are other definitions that will be of assistance in purchasing lubricants. Recommended oil viscosities can be found in this publication, "Fluid Recommendations/ Engine Oil" topic (Maintenance Section).

Engine Oil

Commercial Oils

Perkins recommends use of Perkins Diesel Engine Oil for all Perkins engines. Perkins unique oil formulations have been developed to provide full performance and maximum service life of your engine, and in tests have been shown to provide superior protection. Available in suitable API classifications to meet the emissions requirements and performance of your engine, Refer to 16 for the correct oil specification for your engine. Consult your Perkins distributor for more information on these multi-grade oils.

NOTICE

Perkins require the use of the following specification of engine oil. Failure to use the appropriate specification of engine oil will reduce the life of your engine. Failure to use the appropriate specification of engine oil will also reduce the life of your aftertreatment system.

Table 16

Classifications for the 1200 Series Industrial Engine
Oil Specification
API CK-4 ACEA E9 ECF-3

API CK-4 and ACEA E9 oil categories have the following chemical limits:

- 0.1 percent maximum sulfated ash
- 0.12 percent maximum phosphorous
- 0.4 percent maximum sulfur

The chemical limits were developed to maintain the expected life of the engine aftertreatment system. The performance of the engine aftertreatment system can be adversely affected if oil that is not specified in table 16 is used.

The life of your Aftertreatment system is defined by the accumulation of ash on the surface of the filter. Ash is the inert part of the particulate matter. The system is designed to collect this particulate matter. There is a very small percentage of particulate matter that is left behind as the soot is burnt. This matter will eventually block the filter, causing loss of performance and increased fuel consumption. Most of the ash comes from the engine oil which is gradually consumed during normal operation. This ash passes through the exhaust. To meet the designed life of the product, the use of the appropriate engine oil is essential. The oil specification that is listed in table 16 has low ash content.

Maintenance intervals for engines that use biodiesel – The oil change interval can be adversely affected by the use of biodiesel. Use oil analysis to monitor the condition of the engine oil. Use oil analysis also to determine the oil change interval that is optimum.

Note: API FA-4 oil is designed for use in selected on-highway applications and is NOT designed to support off-road applications, including Perkins Engines. DO NOT use API FA-4 oil for Perkins engines. These engine oils are not approved by Perkins and these engine oils must not be used: CC, CD, CD-2, CF-4, CG-4, CH-4, and CI-4.

Lubricant Viscosity Recommendations for Direct Injection (DI) Diesel Engines

The correct SAE viscosity grade of oil is determined by the minimum ambient temperature during cold engine start-up, and the maximum ambient temperature during engine operation.

Refer to illustration 37 (minimum temperature) to determine the required oil viscosity for starting a cold engine.

Refer to illustration 37 (maximum temperature) to select the oil viscosity for engine operation at the highest ambient temperature that is anticipated.

Generally, use the highest oil viscosity that is available to meet the requirement for the temperature at start-up.

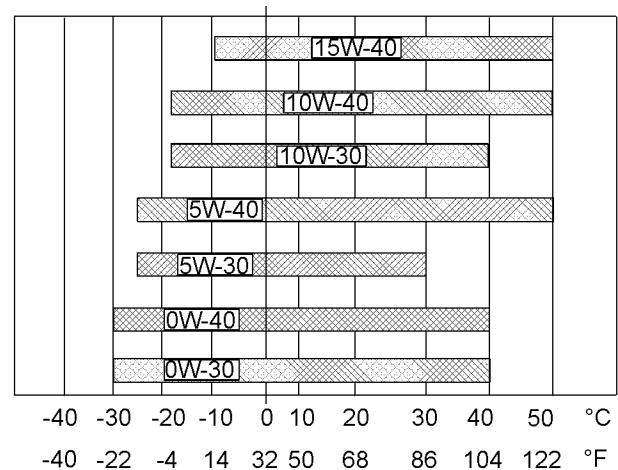

Illustration 37

g03329707

Lubricant Viscosities

Supplemental heat is recommended for cold soaked starts below the minimum ambient temperature. Supplemental heat may be required for cold soaked starts that are above the minimum temperature that is stated, depending on the parasitic load and other factors. Cold soaked starts occur when the engine has not been operated for a period of time. This interval will allow the oil to become more viscous due to cooler ambient temperatures.

Aftermarket Oil Additives

Perkins does not recommend the use of aftermarket additives in oil. The use of aftermarket additives is not necessary to achieve the engines maximum service life or rated performance. Fully formulated, finished oils consist of base oils and of commercial additive packages. These additive packages are blended into the base oils at precise percentages to help provide finished oils with performance characteristics that meet industry standards.

There are no industry standard tests that evaluate the performance or the compatibility of aftermarket additives in finished oil. Aftermarket additives may not be compatible with the finished oils additive package, which could lower the performance of the finished oil. The aftermarket additive could fail to mix with the finished oil. This failure could produce sludge in the crankcase. Perkins discourages the use of aftermarket additives in finished oils.

To achieve the best performance from a Perkins engine, conform to the following guidelines:

- See the appropriate “Lubricant Viscosities”. Refer to the illustration 37 to find the correct oil viscosity grade for your engine.
- At the specified interval, service the engine. Use new oil and install a new oil filter.
- Perform maintenance at the intervals that are specified in the Operation and Maintenance Manual, “Maintenance Interval Schedule”.

Oil analysis

Some engines may be equipped with an oil sampling valve. If oil analysis is required, the oil sampling valve is used to obtain samples of the engine oil. The oil analysis will complement the preventive maintenance program.

The oil analysis is a diagnostic tool that is used to determine oil performance and component wear rates. Contamination can be identified and measured by using oil analysis. The oil analysis includes the following tests:

- The Wear Rate Analysis monitors the wear of the engines metals. The amount of wear metal and type of wear metal that is in the oil is analyzed. The increase in the rate of engine wear metal in the oil is as important as the quantity of engine wear metal in the oil.
- Tests are conducted to detect contamination of the oil by water, glycol, or fuel.

- The Oil Condition Analysis determines the loss of the oils lubricating properties. An infrared analysis is used to compare the properties of new oil to the properties of the used oil sample. This analysis allows technicians to determine the amount of deterioration of the oil during use. This analysis also allows technicians to verify the performance of the oil according to the specification during the entire oil change interval.

i09697829

Fluid Recommendations (General Fuel Information)

• Glossary

- ISO _____International Standards Organization
- ASTM _____American Society for Testing and Materials
- HFRR _____High Frequency Reciprocating Rig for Lubricity testing of diesel fuels
- FAME _____Fatty Acid Methyl Esters
- CFR _____Co-ordinating Fuel Research
- ULSD _____Ultra Low Sulfur Diesel
- RME _____Rape Methyl Ester
- SME _____Soy Methyl Ester
- EPA _____Environmental Protection Agency of the United States
- PPM _____Parts Per Million
- DPF _____Diesel Particulate Filter
- v/v _____(volume of solute)/(volume of solution)
- CFPP _____Cold Filter Plugging Point
- BTL _____Biomass to liquid
- GTL _____Gas to liquid
- CTL _____Coal to liquid
- HVO _____Hydrotreated Vegetable Oil

General Information

NOTICE

Every attempt is made to provide accurate, up-to-date information. By use of this document you agree that Perkins Engines Company Limited is not responsible for errors or omissions.

NOTICE

These recommendations are subject to change without notice. Contact your local Perkins distributor for the most up-to-date recommendations.

Diesel Fuel Requirements

Perkins is not in a position to continuously evaluate and monitor all worldwide distillate diesel fuel specifications that are published by governments and technological societies.

The "Perkins Specification for Distillate Diesel Fuel" provides a known reliable baseline to judge the expected performance of distillate diesel fuels that are derived from conventional sources.

Satisfactory engine performance depends on the use of a good quality fuel. The use of a good quality fuel will give the following results: long engine life and acceptable exhaust emissions levels. The fuel must meet the minimum requirements that are stated in the table 17 .

NOTICE

The footnotes are key part of the Perkins "Specification for Distillate Diesel Fuel" Table. Read ALL of the footnotes.

Table 17

"Perkins Specification for Distillate Diesel Fuel"				
Property	UNITS	Requirements	"ASTM"Test	"ISO/Other"Test
Aromatics	%Volume	35% maximum	"D1319"	"ISO 3837"
Ash	%Weight	0.01% maximum	"D482"	"ISO 6245"
Carbon Residue on 10% Bottoms	%Weight	0.35% maximum	"D524"	"ISO 4262"
Cetane Number ⁽¹⁾	-	40 minimum	"D613 or D6890"	"ISO 5165"
Cloud Point	°C	The cloud point must not exceed the lowest expected ambient temperature.	"D2500"	"ISO 3015"
Copper Strip Corrosion	-	No. 3 maximum	"D130"	"ISO 2160"
Distillation	°C	10% at 238° C (460.4° F) maximum	"D86"	"ISO 3405"

(continued)

Maintenance Section
General Fuel Information

(Table 17, contd)

		90% at 350° C (662° F) maximum		
Density at 15 °C (59 °F) (2)	kg/M ³	800 minimum and 860 maximum	No equivalent test	"ISO 3675""ISO 12185"
Flash Point	°C	legal limit	"D93"	"ISO 2719"
Thermal Stability	-	Minimum of 80% reflectance after aging for 180 minutes at 150 °C (302 °F)	"D6468"	No equivalent test
Pour Point	°C	6 °C (42.8 °F) minimum below ambient temperature	"D97"	"ISO 3016"
Sulfur ⁽³⁾	%mass	0.0015 % maximum	"D5453"	"ISO 20846"
Kinematic Viscosity (4)	MM2/S (cSt)	The viscosity of the fuel that is delivered to the fuel injection pump. 1.4 minimum and 4.5 maximum	"D445"	"ISO 3405"
Water and sediment	% weight	0.05% maximum	"D1796"	"ISO 3734"
Water	% weight	0.05% maximum	"D1744"	No equivalent test
Sediment	% weight	0.05% maximum	"D473"	"ISO 3735"
Gums and Resins (5)	mg/100mL	10 mg per 100 mL maximum	"D381"	"ISO 6246"
Lubricity corrected wear scar diameter at 60 °C (140 °F). (6)	mm	0.52 maximum	"D6079"	"ISO 12156-1"
Fuel Cleanliness (7)	-	"ISO 18/16/13"	"D7619"	"ISO 4406"
Trace Metals (8)	mg/mg	Max 1 or non-detectable	"D7111"	
Oxidation Stability	g/m ³	Max 25	"D2274"	"ISO 12205"
	Hours ⁽⁹⁾	Min 20		"EN 15751"

- (1) To insure minimum cetane number of 40 a distillate diesel fuel should have minimum cetane index of 44 when "ASTM D4737" test method is used. A fuel with a higher cetane number is recommended to operate at a higher altitude or in cold weather
- (2) Density range allowed includes summer and winter diesel fuel grades.
- (3) Ultra Low Sulfur Diesel Fuel with sulphur content less than 0.0015 percent 15 PPM (mg/kg) must be used. Use of diesel fuel with higher than 15 PPM sulphur limit in these engines will harm or permanently damage emissions control systems. Also, use of diesel fuel with higher than 15 PPM sulphur limit can shorten service interval.
- (4) The values of the fuel viscosity are the values as the fuel is delivered to the fuel injection pumps. Fuel should also meet the minimum viscosity requirement and the fuel should meet the maximum viscosity requirements at 40 °C (104 °F) of either the "ASTM D445" test method or the "ISO 3104" test method. If a fuel with a low viscosity is used, cooling of the fuel may be required to maintain "1.4 cSt" or greater viscosity at the fuel injection pump. Fuels with a high viscosity might require fuel heaters to lower the viscosity to "1.4 cSt" at the fuel injection pump.
- (5) Follow the test conditions and procedures for gasoline (motor).
- (6) The lubricity of a fuel is a concern with low sulfur and ultra low sulfur fuel. To determine the lubricity of the fuel, use the "ISO 12156-1 or ASTM D6079 High Frequency Reciprocating Rig (HFRR)" test. If the lubricity of a fuel does not meet the minimum requirements, consult your fuel supplier. Do not treat the fuel without consulting the fuel supplier. Some additives are not compatible. These additives can cause problems in the fuel system.
- (7) Recommended cleanliness level for fuel as dispensed into machine or engine fuel tank is "ISO 18/16/13" or cleaner as per "ISO 4406". Refer to the "Contamination Control Recommendations for Fuels."
- (8) Examples of trace metals include but not limited to Cu, Fe, Mn, Na, P, Pb, Si, and Zn. Use of metal-based additives is not allowed.
- (9) Additional limit for fuel containing FAME. Fuel containing more than 2% v/v FAME must meet both tests.

Engines that are manufactured by Perkins are certified with the fuel that is prescribed by the United States Environmental Protection Agency. Engines that are manufactured by Perkins are certified with the fuel that is prescribed by the European Certification. Perkins does not certify diesel engines on any other fuel.

Note: The owner and the operator of the engine has the responsibility of using the fuel that is prescribed by the EPA and other appropriate regulatory agencies.

NOTICE

Operating with fuels that do not meet the Perkins recommendations can cause the following effects: Starting difficulty, reduced fuel filter service life, poor combustion, deposits in the fuel injectors, significantly reduce service life of the fuel system. Also, the creation of deposits in the combustion chamber and reduced service life of the engine.

NOTICE

The Perkins 1200 series of diesel engine must be operated using Ultra Low Sulfur Diesel. The sulphur content of this fuel must be lower than 15 PPM. This fuel complies with the emissions regulations that are prescribed by the Environmental Protection Agency of the United States.

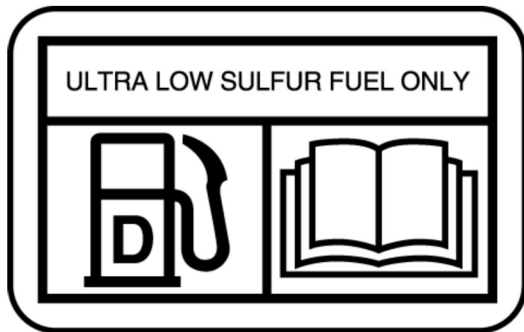

Illustration 38

g02157153

Illustration 38 is a representation of the label that will be installed next to the fuel filler cap on the fuel tank of the application.

The fuel specifications that are listed in the table 18 are released as acceptable to use on all 1200 series of engine.

Table 18

Acceptable Fuel Specification for the 1200 Series of Engines ⁽¹⁾	
Fuel Specification	Comments
EN590	European Automotive Diesel Fuel (DERV)
"ASTM D975 GRADE 1D S15"	"North American Light Distillate Diesel fuel with less than 15 PPM sulfur level"
"ASTM D975 GRADE 2D S15"	"North American Middle Distillate general-purpose Diesel fuel with less than 15 PPM sulfur level"
"JIS K2204"	"Japanese Diesel Fuel" Must meet the requirements that are stated in the section "Lubricity".
"BS 2869: 2010 CLASS A2 or EU equivalent"	"EU Off-Road Diesel fuel. Acceptable from 2011 MUST have less than 10 PPM sulfur level"

⁽¹⁾ All the fuels must comply with the specification in the table for the Perkins Specification Distillate Diesel Fuel.

Diesel Fuel Characteristics

Cetane Number

Fuel that has a high cetane number will give a shorter ignition delay. A high cetane number will produce a better ignition quality. Cetane numbers are derived for fuels against proportions of cetane and heptamethylnonane in the standard CFR engine. Refer to "ISO 5165" for the test method.

Cetane numbers more than 45 are normally expected from current diesel fuel. However, a cetane number of 40 may be experienced in some territories. The United States of America is one of the territories that can have a low cetane value. A minimum cetane value of 40 is required during average starting conditions. A fuel with higher cetane number is recommended for operations at high altitudes or in cold-weather operations.

Fuel with a low cetane number can be the root cause of problems during a cold start.

Viscosity

Viscosity is the property of a liquid of offering resistance to shear or flow. Viscosity decreases with increasing temperature. This decrease in viscosity follows a logarithmic relationship for normal fossil fuel. The common reference is to kinematic viscosity. Kinematic viscosity is the quotient of the dynamic viscosity that is divided by the density. The determination of kinematic viscosity is normally by readings from gravity flow viscometers at standard temperatures. Refer to "ISO 3104" for the test method.

The viscosity of the fuel is significant because fuel serves as a lubricant for the fuel system components. Fuel must have sufficient viscosity to lubricate the fuel system in both extremely cold temperatures and extremely hot temperatures. If the kinematic viscosity of the fuel is lower than "1.4 cSt" at the fuel injection pump, damage to the fuel injection pump can occur. This damage can be excessive scuffing and seizure. Low viscosity may lead to difficult hot restarting, stalling, and loss of performance. High viscosity may result in seizure of the pump.

Perkins recommends kinematic viscosities of 1.4 and 4.5 mm²/sec that is delivered to the fuel injection pump. If a fuel with a low viscosity is used, cooling of the fuel may be required to maintain 1.4 cSt or greater viscosity at the fuel injection pump. Fuels with a high viscosity might require fuel heaters to lower the viscosity to 4.5 cSt at the fuel injection pump.

Density

Density is the mass of the fuel per unit volume at a specific temperature. This parameter has a direct influence on engine performance and a direct influence on emissions. This influence determines from a heat output given injected volume of fuel. This parameter is quoted in the following kg/m³ at 15 °C (59 °F).

Perkins recommends a density of 841 kg/m³ to obtain the correct power output. Lighter fuels are acceptable but these fuels will not produce the rated power.

Sulfur

The level of sulfur is governed by emissions legislations. Regional regulation, national regulations, or international regulations can require a fuel with a specific sulfur limit. The sulfur content of the fuel and the fuel quality must comply with all existing local regulations for emissions.

Perkins 1200 series diesel engines have been designed to operate only with ULSD. By using the test methods "ASTM D5453, or ISO 20846", the content of sulfur in ULSD fuel must be below 15 PPM (mg/kg) or 0.0015% mass.

NOTICE

Use of diesel fuel with higher than 15 PPM sulphur limit in these engines will harm or permanently damage emissions control systems and/or shorten service interval.

Lubricity

Lubricity is the capability of the fuel to prevent pump wear. The fluids lubricity describes the ability of the fluid to reduce the friction between surfaces that are under load. This ability reduces the damage that is caused by friction. Fuel injection systems rely on the lubricating properties of the fuel. Until fuel sulfur limits were mandated, the fuels lubricity was generally believed to be a function of fuel viscosity.

The lubricity has particular significance to the current ultra low sulfur fuel, and low aromatic fossil fuels. These fuels are made to meet stringent exhaust emissions.

The lubricity of these fuels must not exceed wear scar diameter of 0.52 mm (0.0205 inch). The fuel lubricity test must be performed on an HFRR, operated at 60 °C (140 °F). Refer to "ISO 12156-1".

NOTICE

The fuels system has been qualified with fuel having lubricity up to 0.52 mm (0.0205 inch) wear scar diameter as tested by "ISO 12156-1". Fuel with higher wear scar diameter than 0.52 mm (0.0205 inch) will lead to reduced service life and premature failure of the fuel system.

Fuel additives can enhance the lubricity of a fuel. Contact your fuel supplier for those circumstances when fuel additives are required. Your fuel supplier can make recommendations for additives to use, and for the proper level of treatment.

Distillation

Distillation is an indication of the mixture of different hydrocarbons in the fuel. A high ratio of lightweight hydrocarbons can affect the characteristics of combustion.

Recommendation for Biodiesel and Using B20

Biodiesel is a fuel that can be defined as mono-alkyl esters of fatty acids. Biodiesel is a fuel that can be made from various feedstocks. The most commonly available biodiesel in Europe is Rape Methyl Ester (RME). This biodiesel is derived from rapeseed oil. Soy Methyl Ester (SME) is the most common biodiesel in the United States. This biodiesel is derived from soybean oil. Soybean oil or rapeseed oil are the primary feedstocks. These fuels are together known as Fatty Acid Methyl Esters (FAME).

Raw pressed vegetable oils are NOT acceptable for use as a fuel in any concentration in compression engines. Without esterification, these oils solidify in the crankcase and the fuel tank. These fuels may not be compatible with many of the elastomers that are used in engines that are manufactured today. In original forms, these oils are not suitable for use as a fuel in compression engines. Alternate base stocks for biodiesel may include animal tallow, waste cooking oils, or various other feedstocks. To use any of the products that are listed as fuel, the oil must be esterified.

Fuel made of 100 percent FAME is generally referred to as B100 biodiesel or neat biodiesel.

Biodiesel can be blended with distillate diesel fuel. The blends can be used as fuel. The most commonly available biodiesel blends are B5, which is 5 percent biodiesel and 95 percent distillate diesel fuel. B20, which is 20 percent biodiesel and 80 percent distillate diesel fuel.

Note: The percentages given are volume-based.

The U.S. distillate diesel fuel specification "ASTM D975-09a" includes up to B5 (5 percent) biodiesel.

European distillate diesel fuel specification EN590: 2010 includes up to B7 (7 percent) biodiesel.

Note: Engines that are manufactured by Perkins are certified by use of the prescribed Environmental Protection Agency (EPA) and European Certification fuels. Perkins does not certify engines on any other fuel. The user of the engine has the responsibility of using the correct fuel that is recommended by the manufacturer and allowed by the EPA and other appropriate regulatory agencies.

Specification Requirements

The neat biodiesel must conform to the latest "EN14214 or ASTM D6751" (in the USA). The biodiesel can only be blended in mixture of up to 20% by volume in acceptable mineral diesel fuel meeting latest edition of "EN590 or ASTM D975 S15" designation.

In United States Biodiesel blends of B6 to B20 must meet the requirements listed in the latest edition of "ASTM D7467" (B6 to B20) and must be of an API gravity of 30-45.

In North America biodiesel and biodiesel blends must be purchased from the BQ-9000 accredited producers and BQ-9000 certified distributors.

In other areas of the world, the use of biodiesel that is BQ-9000 accredited and certified, or that is accredited and certified by a comparable biodiesel quality body to meet similar biodiesel quality standards is required.

Engine Service Requirements

Aggressive properties of biodiesel fuel may cause debris in the fuel tank and fuel lines. The aggressive properties of biodiesel will clean the fuel tank and fuel lines. This cleaning of the fuel system can prematurely block of the fuel filters. Perkins recommend that after the initial usage of B20 biodiesel blended fuel the fuel filters must be replaced at 50 hours.

Glycerides present in biodiesel fuel will also cause fuel filters to become blocked more quickly. Therefore the regular service interval should be reduced to 250 hours.

When biodiesel fuel is used, crank case oil and aftertreatment systems may be influenced. This influence is due to the chemical composition and characteristics of biodiesel fuel, such as density and volatility, and to chemical contaminants that can be present in this fuel, such as alkali and alkaline metals (sodium, potassium, calcium, and magnesium).

- Crankcase oil fuel dilution can be higher when biodiesel or biodiesel blends are used. This increased level of fuel dilution when using biodiesel or biodiesel blends is related to the typically lower volatility of biodiesel. In-cylinder emissions control strategies utilized in many of the industrial latest engine designs may lead to a higher level of biodiesel concentration in the sump. The long-term effect of biodiesel concentration in crankcase oil is unknown currently.
- Perkins recommend the use of oil analysis to check the quality of the engine oil if biodiesel fuel is used. Ensure that the level of biodiesel in the fuel is noted when the oil sample is taken.

Performance-Related Issues

Due to the lower energy content than the standard distillate fuel B20 will cause a power loss in order of 2 to 4 percent. In addition, over time the power may deteriorate further due to deposits in the fuel injectors.

Biodiesel and biodiesel blends are known to cause an increase in fuel system deposits, most significant of which are deposits within the fuel injector. These deposits can cause a loss in power due to restricted or modified fuel injection or cause other functional issues associated with these deposits.

Note: Perkins T40-0012 Fuel Cleaner is most effective in cleaning and preventing the formation of deposits. For more information refer to “Perkins Diesel Fuel System Cleaner, and Perkins”.

Biodiesel fuel contains metal contaminants (sodium, potassium, calcium, and/or magnesium) that form ash products upon combustion in the diesel engine. The ash can have an impact on the life and performance of aftertreatment emissions control devices and can accumulate in DPF. The ash accumulation may cause the need for more frequent ash service intervals and causes loss of performance

General Requirements

Biodiesel has poor oxidation stability, which can result in long-term problems in the storage of biodiesel. Biodiesel fuel should be used within 6 months of manufacture. Equipment should not be stored with the B20 biodiesel blends in the fuel system for longer than 3 months.

Due to poor oxidation stability and other potential issues, it is strongly recommended that engines with limited operational time either not use B20 biodiesel blends or, whilst accepting some risk, limit biodiesel blend to a maximum of B5. Examples of applications that should limit the use of biodiesel are the following: Standby Generator sets and certain emergency vehicles.

For standby generator sets and emergency vehicles that cannot avoid use of biodiesel blends fuel quality in the engine fuel tank must be sampled and checked monthly. Test should include acid number (EN14104), oxidation stability (EN 15751 commonly known as the Rancimat test), and sediment (ISO12937). For standby generator sets oxidation stability of biodiesel blend must be 20 hours or more as per EN 15751. If the test shows that the fuel has degraded, fuel tank must be drained and engine flashed by running with the fresh high-quality diesel fuel.

Perkins strongly recommended that seasonally operated engines have the fuel systems, including fuel tanks, flashed with conventional diesel fuel before prolonged shutdown periods. An example of an application that should seasonally flush the fuel system is a combine harvester.

Microbial contamination and growth can cause corrosion in the fuel system and premature plugging of the fuel filter. Consult your supplier of fuel for assistance in selecting appropriate anti-microbial additive.

Water accelerates microbial contamination and growth. When biodiesel is compared to distillate fuels, water is naturally more likely to exist in the biodiesel. Therefore check frequently and if necessary, drain the water separator.

Materials such as brass, bronze, copper, lead, tin, and zinc accelerate the oxidation process of the biodiesel fuel. The oxidation process can cause deposits formation therefore these materials must not be used for fuel tanks and fuel lines.

Renewable and Alternative Fuels

Perkins supports development and use of renewable fuels through sustainability initiatives. In recent years various forms of renewable and alternative (synthetic) diesel fuels have started to emerge.

Synthetic diesel fuels are produced by gasification of various feedstock and then synthesis to liquid to obtain paraffinic diesel fuel. Based on the feedstock used these fuels are commonly referred to as Biomass to liquid (BTL), Gas to liquid (GTL) and Coal to liquid (CTL). Hydrotreating of vegetable oils and animal fats is another emerging process for production of bio based diesel fuel called Hydrotreated Vegetable Oil (HVO).

BTL and HVO fuels are considered to be low carbon fuels as they reduce carbon foot print compared to fossil fuels and are commonly referred to as renewable fuels. These fuels must not be confused with biodiesel FAME which is fundamentally different fuel and is discussed in a separate section in this manual.

These paraffinic fuels have virtually no sulphur or aromatics and have very high cetane numbers which enable very clean burning and efficient engine operation. Chemically these fuels are similar to diesel fuel derived from petroleum and are therefore suitable to use in diesel engines as a replacement or blend stock with conventional diesel fuel. To be acceptable renewable and alternative fuels must meet latest edition of the paraffinic diesel fuel specification "CENTS 15940". The fuel should also meet requirements described in table 17, Perkins Specification for Distillate Diesel Fuel, EN590, or latest ASTM D975 specification.

Ensure that the fuel has appropriate cold flow properties (cloud point and CFPP) for the minimum statistical ambient temperature the engine is expected to see in the operation. The Fuel must also meet lubricity requirements as specified in the lubricity section of this "Operation and Maintenance Manual" Fluid Recommendations

Fuel for Cold-Weather Operation

The European standard "EN590" contains climate dependant requirements and a range of options. The options can be applied differently in each country. There are five classes that are given to arctic climates and severe winter climates. 0, 1, 2, 3 and 4.

Fuel that complies with "EN590" CLASS 4 can be used at temperatures as low as $-44\text{ }^{\circ}\text{C}$ ($-47.2\text{ }^{\circ}\text{F}$). Refer to "EN590" for a detailed discretion of the physical properties of the fuel.

The diesel fuel "ASTM D975 1-D" used in the United States of America may be used in very cold temperatures that are below $-18\text{ }^{\circ}\text{C}$ ($-0.4\text{ }^{\circ}\text{F}$).

Aftermarket Fuel Additives

NOTICE

Perkins does not warrant the quality or performance of non-Perkins fluids and filters.

When auxiliary devices, accessories, or consumables (filters, additives) which are made by other manufacturers are used on Perkins products, the Perkins warranty is not affected simply because of such use.

However, failures that result from the installation or use of other manufacturers devices, accessories, or consumables are NOT Perkins defects. Therefore, the defects are NOT covered under the Perkins warranty.

Supplemental diesel fuel additives are not generally recommended. This recommendation is due to potential damage to the fuel system or the engine. Your fuel supplier or the fuel manufacturer will add the appropriate supplemental diesel fuel additives.

Perkins recognizes the fact that additives may be required in some special circumstances.

Note: Some anti-corrosion additives can lead to injector fouling, this fouling can cause the injector to operate incorrectly.

Contact your fuel supplier for those circumstances when fuel additives are required. Your fuel supplier can recommend the appropriate fuel additive and the correct level of treatment.

Note: For the best results, your fuel supplier should treat the fuel when additives are required. The treated fuel must meet the requirements that are stated in table 17.

Perkins Diesel Fuel System Cleaner

Perkins T40-0012 Fuel Cleaner is the only fuel cleaner that is recommended by Perkins.

If biodiesel or biodiesel blends of fuel are to be used, Perkins require the use of Perkins fuel cleaner. The use of the fuel is to remove deposits within the fuel system that is created with the use of biodiesel. For more information on the use of biodiesel and biodiesel blends refer to "Recommendation for Biodiesel and Using B20".

Perkins fuel cleaner will remove deposits that can form in the fuel system with the use of biodiesel and biodiesel blends. These deposits can create a loss of power and engine performance.

Once the fuel cleaner has been added to the fuel, the deposits within the fuel system are removed after 30 hours of engine operation. For maximum results, continue to use the fuel cleaner for up to 80 hours. Perkins fuel cleaner can be used on an on-going basis with no adverse impact on engine or fuel system durability.

Details instruction on the rate of which the fuel cleaner must be used are on the container.

Note: Perkins fuel cleaner is compatible with existing and U.S. EPA Tier 4 nonroad certified diesel engine emission control catalysts and particulate filters. Perkins fuel system cleaner contains less than 15 ppm of sulfur and is acceptable for use with ULSD fuel.

Contamination Control Recommendations for Fuels

Fuels of “ISO 18/16/13” cleanliness level or cleaner as dispensed into the engine or application fuel tank should be used. This will reduce risk of power loss, fuel system failures, and related down time of engines. This cleanliness level is important for new fuel system designs such as common rail injection systems and unit injectors. These fuels systems utilize higher fuel injection pressures and have tight clearances between moving parts to meet required stringent emissions regulations. Peak injection pressures in current fuel injection systems may exceed 2000 bar (29000 psi). Clearances in these systems are less than 5 μm . As a result, particle contaminants as small as 4 μm can cause scoring and scratching of internal pump and injector surfaces and of injector nozzles.

Water in the fuel causes cavitation, corrosion of fuel system parts, and provides an environment where microbial growth in the fuel can flourish. Other sources of fuel contamination are soaps, gels, or other compounds that may result from undesirable chemical interactions in the fuels, particularly in ULSD. Gels and other compounds can also form in biodiesel fuel at low temperatures or if biodiesel is stored for extended periods. The best indication of microbial contamination, fuel additives, or cold temperature gel is rapid filter plugging of bulk fuel filters or application fuel filters.

To reduce downtime due to contamination, follow these fuel maintenance guidelines.

- Use high-quality fuels per recommended and required specifications
- Fill fuel tanks with fuels of “ISO 18/16/13” cleanliness level or cleaner, in particular for engines with common rail and unit injection systems. When you refuel the tank, filter the fuel through a 4 μm absolute filter (Beta 4 = 75 up to 200) to reach the recommended cleanliness level. This filtration should be installed at the device that dispenses the fuel to the fuel tank. In addition, filtration at the dispensing point should remove water to ensure that fuel is dispensed at 500 ppm water or less.
- Perkins recommends the use of bulk fuel filter / coalescer units which clean the fuel of both particulate contamination and water in a single pass.
- Ensure that you use Perkins Advanced Efficiency Fuel Filters. Change your fuel filters per recommended service requirements or as needed.
- Drain your water separators daily.
- Drain your fuel tanks of sediment and water per the Operation and Maintenance Manual instructions.
- Install and maintain a properly designed bulk filter / coalescer filtration system. Continuous bulk filtration systems may be required to ensure that dispensed fuel meets the cleanliness target. Consult your Perkins distributor for availability of bulk filtration products.
- Centrifugal filters may need to be used as a pre-filter with fuel that is severely contaminated with gross amounts of water and/or large particulate contaminants. Centrifugal filters can effectively remove large contaminants. Centrifugal filters may not be able to remove the small abrasive particles required to achieve the recommended “ISO” cleanliness level. Bulk filter / coalescers are necessary as a final filter to achieve the recommended cleanliness level.
- Install desiccant type breathers of 4 μm or less absolute efficiency with the ability to remove water on bulk storage tanks.
- Follow proper practices of fuel transportation. Filtration from the storage tank to the application promotes the delivery of clean fuel. Fuel filtration can be installed at each transport stage to keep the fuel clean.
- Cover, protect, and ensure cleanliness of all connection hoses, fittings, and dispensing nozzles.

Consult your local Perkins distributor for additional information on Perkins designed and produced filtration products.

Maintenance Recommendations

i07819420

System Pressure Release

Coolant System

WARNING

Pressurized system: Hot coolant can cause serious burn. To open cap, stop engine, wait until radiator is cool. Then loosen cap slowly to relieve the pressure.

WARNING

When the engine is in the AUTOMATIC mode, the engine can start at any moment. To avoid personal injury, always remain clear of the engine when the engine is in the AUTOMATIC mode.

The engine can have the ability to auto start. Ensure that the power supply is isolated before any service or repair is performed.

To relieve the pressure from the coolant system, turn off the engine. Allow the cooling system pressure cap to cool. Remove the cooling system pressure cap slowly to relieve pressure.

Fuel System

To relieve the pressure from the fuel system, turn off the engine.

High-Pressure Fuel Lines

WARNING

Contact with high pressure fuel may cause fluid penetration and burn hazards. High pressure fuel spray may cause a fire hazard. Failure to follow these inspection, maintenance and service instructions may cause personal injury or death.

The high-pressure fuel lines are the fuel lines that are between the high-pressure fuel pump and the high-pressure fuel manifold and the fuel lines that are between the fuel manifold and the fuel injectors.

The high-pressure fuel lines are different from fuel lines on other fuel systems, the differences are as follows:

- The high-pressure fuel lines are constantly charged with high pressure.
- The internal pressures of the high-pressure fuel lines are higher than other types of fuel system.

Before any service or repair is performed on the engine fuel lines, perform the following tasks:

1. Stop the engine.
2. Wait for 10 minutes.

Do not loosen the high-pressure fuel lines to remove air from the fuel system.

Engine Oil

To relieve pressure from the lubricating system, turn off the engine.

i07915408

Welding on Engines with Electronic Controls

NOTICE

Because the strength of the frame may decrease, some manufacturers do not recommend welding onto a chassis frame or rail. Consult the OEM of the equipment or your Perkins dealer regarding welding on a chassis frame or rail.

Correct welding procedures are necessary to avoid damage to the engines ECM, sensors, and associated components. When possible, remove the component from the unit and then weld the component. If removal of the component is not possible, the following procedure must be followed when you weld on a unit equipped with an Electronic Engine. The following procedure is considered to be the safest procedure to weld on a component. This procedure should provide a minimum risk of damage to electronic components.

NOTICE

Do not ground the welder to electrical components such as the ECM or sensors. Improper grounding can cause damage to the drive train bearings, hydraulic components, electrical components, and other components.

Clamp the ground cable from the welder to the component that will be welded. Place the clamp as close as possible to the weld. This will help reduce the possibility of damage.

Note: Perform the welding in areas that are free from explosive hazards.

Maintenance Section
Welding on Engines with Electronic Controls

1. Stop the engine. Turn the switched power to the OFF position.
2. Ensure that the fuel supply to the engine is turned off.
3. Disconnect the negative battery cable from the battery. If a battery disconnect switch is provided, open the switch.
4. Disconnect all electronic components from the wiring harnesses. Include the following components:
 - Electronic components for the driven equipment
 - ECM
 - Sensors
 - Electric operated fuel pump
 - Electronically controlled valves
 - Relays
 - Aftertreatment ID module

NOTICE

Do not use electrical components (ECM or ECM sensors) or electronic component grounding points for grounding the welder.

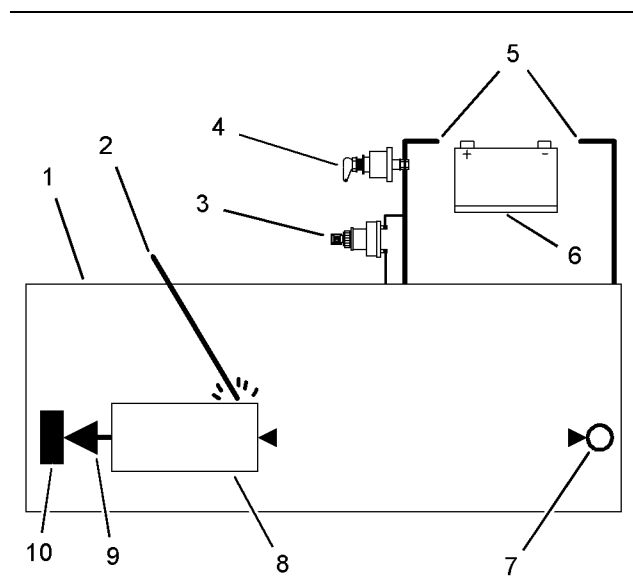

Illustration 39

g06477753

Use the example above. The current flow from the welder to the ground clamp of the welder will not damage any associated components.

- (1) Engine
- (2) Welding electrode
- (3) Keyswitch in the OFF position
- (4) Battery disconnect switch in the open position
- (5) Disconnected battery cables
- (6) Battery
- (7) Electrical/Electronic component
- (8) The component that is being welded
- (9) Current path of the welder
- (10) Ground clamp for the welder

5. Connect the welding ground cable directly to the part that will be welded. Place the ground cable as close as possible to the weld to reduce the possibility of welding current damage to the following components. Bearings, hydraulic components, electrical components, and ground straps.

Note: If electrical/electronic components are used as a ground for the welder, or electrical/electronic components are located between the welder ground and the weld, current flow from the welder could severely damage the component.

6. Protect the wiring harness from welding debris and spatter.
7. Use standard welding practices to weld the materials.

i09722776

Maintenance Interval Schedule

When Required

“ Battery - Replace”	82
“ Battery or Battery Cable - Disconnect”	83
“ Engine - Clean”	91
“ Engine Air Cleaner Element (Dual Element) - Clean/Replace”	91
“ Engine Air Cleaner Element (Single Element) - Inspect/Replace”	93
“ Engine Oil Sample - Obtain”	100
“ Fuel System - Prime”	102
“ Severe Service Application - Check”	110

Daily

“ Cooling System Coolant Level - Check”	88
“ Driven Equipment - Check”	90
“ Engine Air Cleaner Service Indicator - Inspect”	94
“ Engine Air Precleaner - Check/Clean”	94
“ Engine Oil Level - Check”	100
“ Fuel System Primary Filter/Water Separator - Drain”	105
“ Walk-Around Inspection”	112

Every Week

“ Hoses and Clamps - Inspect/Replace”	108
---------------------------------------	-----

Every 50 Service Hours or Weekly

“ Fuel Tank Water and Sediment - Drain”	108
---	-----

Every 500 Service Hours

“ Belt - Inspect”	84
“ Engine Oil and Filter - Change”	101

Every 500 Service Hours or 1 Year

“ Battery Electrolyte Level - Check”	83
“ Cooling System Supplemental Coolant Additive (SCA) - Test/Add”	90

“ Engine Air Cleaner Element (Dual Element) - Clean/Replace”	91
--	----

“ Engine Air Cleaner Element (Single Element) - Inspect/Replace”	93
--	----

“ Fuel System Primary Filter (Water Separator) Element - Replace”	103
---	-----

“ Fuel System Secondary Filter - Replace”	106
---	-----

“ Radiator - Clean”	109
---------------------	-----

Every 1000 Service Hours

“ Water Pump - Inspect”	113
-------------------------	-----

Every 1500 Service Hours

“ Engine Crankcase Breather Element - Replace”	98
--	----

“ Engine Crankcase Breather Element - Replace”	95
--	----

Every 2000 Service Hours

“ Aftercooler Core - Inspect”	82
-------------------------------	----

“ Engine Mounts - Inspect”	99
----------------------------	----

“ Starting Motor - Inspect”	111
-----------------------------	-----

“ Turbocharger - Inspect”	111
---------------------------	-----

Every 3000 Service Hours

“ Alternator - Inspect”	82
-------------------------	----

“ Alternator and Fan Belts - Replace”	82
---------------------------------------	----

“ Belt Tensioner - Inspect”	84
-----------------------------	----

Every 3000 Service Hours or 2 Years

“ Cooling System Coolant (Commercial Heavy-Duty) - Change”	85
--	----

Every 4000 Service Hours

“ Aftercooler Core - Clean/Test”	82
----------------------------------	----

Every 12 000 Service Hours or 6 Years

“ Cooling System Coolant (ELC) - Change”	86
--	----

i01807350

i02322311

Aftercooler Core - Clean/Test (Air-To-Air Aftercooler)

The air-to-air aftercooler is OEM installed in many applications. Please refer to the OEM specifications for information that is related to the aftercooler.

i02322295

Aftercooler Core - Inspect

Note: Adjust the frequency of cleaning according to the effects of the operating environment.

Inspect the aftercooler for these items: damaged fins, corrosion, dirt, grease, insects, leaves, oil and other debris. Clean the aftercooler, if necessary.

For air-to-air aftercoolers, use the same methods that are used for cleaning radiators.

WARNING

Personal injury can result from air pressure.

Personal injury can result without following proper procedure. When using pressure air, wear a protective face shield and protective clothing.

Maximum air pressure at the nozzle must be less than 205 kPa (30 psi) for cleaning purposes.

After cleaning, start the engine and accelerate the engine to high idle rpm. This will help in the removal of debris and drying of the core. Stop the engine. Use a light bulb behind the core in order to inspect the core for cleanliness. Repeat the cleaning, if necessary.

Inspect the fins for damage. Bent fins may be opened with a "comb".

Note: If parts of the aftercooler system are repaired or replaced, a leak test is highly recommended.

Inspect these items for good condition: Welds, mounting brackets, air lines, connections, clamps and seals. Make repairs, if necessary.

Alternator - Inspect

Perkins recommends a scheduled inspection of the alternator. Inspect the alternator for loose connections and correct battery charging. Check the ammeter (if equipped) during engine operation in order to ensure correct battery performance and/or correct performance of the electrical system. Make repairs, as required.

Check the alternator and the battery charger for correct operation. If the batteries are correctly charged, the ammeter reading should be very near zero. All batteries should be kept charged. The batteries should be kept warm because temperature affects the cranking power. If the battery is too cold, the battery will not crank the engine. When the engine is not run for long periods of time or if the engine is run for short periods, the batteries may not fully charge. A battery with a low charge will freeze more easily than a battery with a full charge.

i02680137

Alternator and Fan Belts - Replace

Refer to Disassembly and Assembly Manual, "Alternator Belt - Remove and Install".

i03559623

Battery - Replace

WARNING

Batteries give off combustible gases which can explode. A spark can cause the combustible gases to ignite. This can result in severe personal injury or death.

Ensure proper ventilation for batteries that are in an enclosure. Follow the proper procedures in order to help prevent electrical arcs and/or sparks near batteries. Do not smoke when batteries are serviced.

⚠ WARNING

The battery cables or the batteries should not be removed with the battery cover in place. The battery cover should be removed before any servicing is attempted.

Removing the battery cables or the batteries with the cover in place may cause a battery explosion resulting in personal injury.

1. Switch the engine to the OFF position. Remove all electrical loads.
2. Turn off any battery chargers. Disconnect any battery chargers.
3. Ensure that the battery disconnect switch is in the OFF position.
4. Disconnect the NEGATIVE “-” cable from the NEGATIVE “-” battery terminal.
5. Disconnect the POSITIVE “+” cable from the POSITIVE “+” battery terminal.

Note: Always recycle a battery. Never discard a battery. Dispose of used batteries to an appropriate recycling facility.

6. Remove the used battery.
7. Install the new battery.

Note: Before the cables are connected, ensure that the battery disconnect switch is in the OFF position.

8. Connect the POSITIVE “+” cable to the POSITIVE “+” battery terminal.
9. Connect the NEGATIVE “-” cable to the NEGATIVE “-” battery terminal.
10. Turn the battery disconnect switch to the ON position.

i02747977

Battery Electrolyte Level - Check

When the engine is not run for long periods of time or when the engine is run for short periods, the batteries may not fully recharge. Ensure a full charge in order to help prevent the battery from freezing. If batteries are correctly charged, the ammeter reading should be very near zero, when the engine is in operation.

⚠ WARNING

All lead-acid batteries contain sulfuric acid which can burn the skin and clothing. Always wear a face shield and protective clothing when working on or near batteries.

1. Remove the filler caps. Maintain the electrolyte level to the “FULL” mark on the battery.

If the addition of water is necessary, use distilled water. If distilled water is not available use clean water that is low in minerals. Do not use artificially softened water.

2. Check the condition of the electrolyte with a suitable battery tester.
3. Install the caps.
4. Keep the batteries clean.

Clean the battery case with one of the following cleaning solutions:

- Use a solution of 0.1 kg (0.2 lb) baking soda and 1 L (1 qt) of clean water.
- Use a solution of ammonium hydroxide.

Thoroughly rinse the battery case with clean water.

i09570426

Battery or Battery Cable - Disconnect

⚠ WARNING

The battery cables or the batteries should not be removed with the battery cover in place. The battery cover should be removed before any servicing is attempted.

Removing the battery cables or the batteries with the cover in place may cause a battery explosion resulting in personal injury.

1. Turn the start switch to the OFF position. Turn the ignition switch (if equipped) to the OFF position and remove the key and all electrical loads.
2. Open the battery isolator. Disconnect the negative battery terminal. Ensure that the cable cannot contact the terminal. When four 12 volt batteries are involved, two negative connections must be disconnected.

3. Remove the positive connection.
4. Clean all disconnected connection and battery terminals.
5. Use a fine grade of sandpaper to clean the terminals and the cable clamps. Clean the items until the surfaces are bright or shiny. DO NOT remove material excessively. Excessive removal of material can cause the clamps to not fit correctly. Coat the clamps and the terminals with a suitable silicone lubricant or petroleum jelly.
6. Tape the cable connections to help prevent accidental starting.
7. Proceed with necessary system repairs.
8. To connect the battery, connect the positive connection before the negative connection.

i03973719

Belt - Inspect

NOTICE

Ensure that the engine is stopped before any servicing or repair is performed.

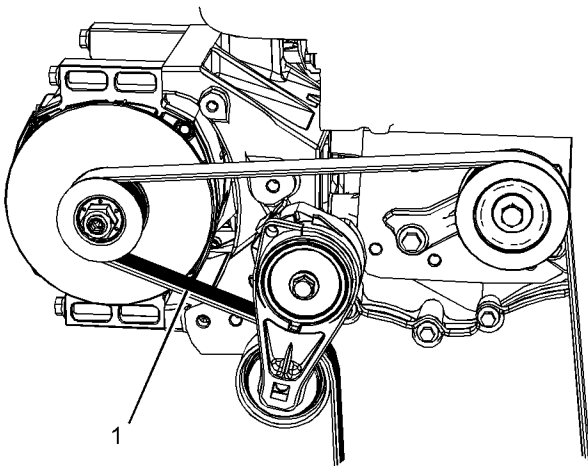

Illustration 40

g01906354

Typical example

To maximize the engine performance, inspect the belt (1) for wear and for cracking. Replace the belt if the belt is worn or damaged.

- Inspect the belt for cracks, splits, glazing, grease, displacement of the cord and evidence of fluid contamination.

The belt must be replaced if the following conditions are present.

- The belt has a crack in more than one rib.
- More than one section of the belt is displaced in one rib of a maximum length of 50.8 mm (2 inch).

To replace the belt, refer to Disassembly and Assembly, "Alternator Belt - Remove and Install". If necessary, replace the belt tensioner. Refer to Disassembly and Assembly, "Alternator Belt - Remove and Install" for the correct procedure.

i03868550

Belt Tensioner - Inspect

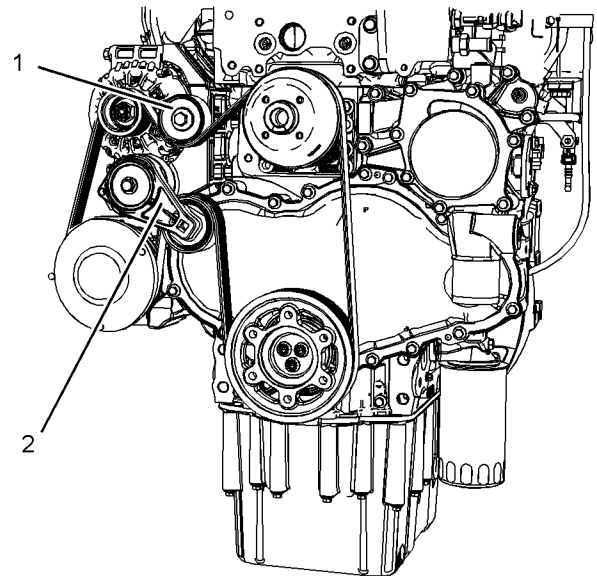

Illustration 41

g02111454

Typical example

Remove the belt. Refer to Disassembly and Assembly, "Alternator Belt - Remove and Install".

Ensure that the belt tensioner is securely installed. Visually inspect the belt tensioner (2) for damage. Check that the pulley on the tensioner rotates freely and that the bearing is not loose. Some engines have an idler pulley (1). Ensure that the idler pulley is securely installed. Visually inspect the idler pulley for damage. Ensure that the idler pulley can rotate freely and that the bearing is not loose. If necessary, replace damaged components.

Install the belt. Refer to Disassembly and Assembly, "Alternator Belt - Remove and Install".

i04007090

Cooling System Coolant (Commercial Heavy-Duty) - Change

NOTICE

Care must be taken to ensure that fluids are contained during performance of inspection, maintenance, testing, adjusting and repair of the product. Be prepared to collect the fluid with suitable containers before opening any compartment or disassembling any component containing fluids.

Dispose of all fluids according to Local regulations and mandates.

NOTICE

Keep all parts clean from contaminants.

Contaminants may cause rapid wear and shortened component life.

Clean the cooling system and flush the cooling system before the recommended maintenance interval if the following conditions exist:

- The engine overheats frequently.
- Foaming of the coolant is observed.
- The oil has entered the cooling system and the coolant is contaminated.
- The fuel has entered the cooling system and the coolant is contaminated.

Note: When the cooling system is cleaned, only clean water is needed.

NOTICE

When any servicing or repair of the engine cooling system is performed the procedure must be performed with the engine on level ground. This will allow you to accurately check the coolant level. This will also help in avoiding the risk of introducing an air lock into the coolant system.

Drain

WARNING

Pressurized System: Hot coolant can cause serious burns. To open the cooling system filler cap, stop the engine and wait until the cooling system components are cool. Loosen the cooling system pressure cap slowly in order to relieve the pressure.

1. Stop the engine and allow the engine to cool. Loosen the cooling system filler cap slowly in order to relieve any pressure. Remove the cooling system filler cap.

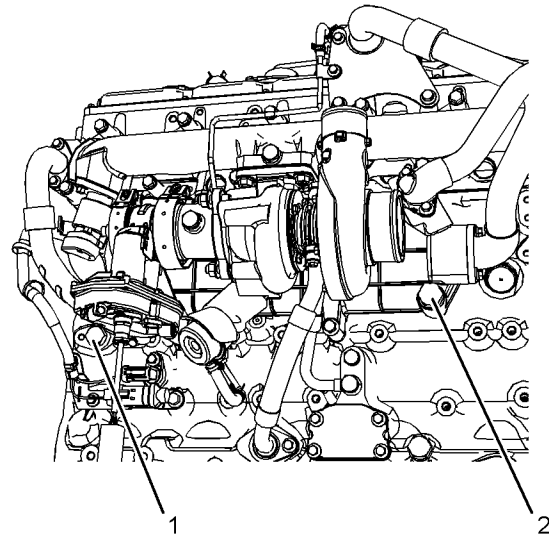

Illustration 42

g02177998

Typical example

2. Open the drain cock or remove the drain plug (1) on the engine. Also, remove the drain plug (2). Open the drain cock or remove the drain plug on the radiator.

Allow the coolant to drain.

NOTICE

Dispose of used engine coolant or recycle. Various methods have been proposed to reclaim used coolant for reuse in engine cooling systems. The full distillation procedure is the only method acceptable by Perkins to reclaim the coolant.

Maintenance Section
Cooling System Coolant (ELC) - Change

For information regarding the disposal and the recycling of used coolant, consult your Perkins dealer or your Perkins distributor.

Flush

1. Flush the cooling system with clean water in order to remove any debris.
2. Close the drain cock or install the drain plug in the engine. Close the drain cock or install the drain plug on the radiator.

NOTICE

Do not fill the cooling system faster than 5 L (1.3 US gal) per minute, in order to avoid air locks.

Cooling system air locks may result in engine damage.

3. Fill the cooling system with clean water. Install the cooling system filler cap.
4. Start and run the engine at low idle until the temperature reaches 49 to 66 °C (120 to 150 °F).
5. Stop the engine and allow the engine to cool. Loosen the cooling system filler cap slowly in order to relieve any pressure. Remove the cooling system filler cap. Open the drain cock or remove the drain plug on the engine. Open the drain cock or remove the drain plug on the radiator. Allow the water to drain. Flush the cooling system with clean water.

Fill

1. Close the drain cock or install the drain plug on the engine. Close the drain cock or install the drain plug on the radiator.

NOTICE

Do not fill the cooling system faster than 5 L (1.3 US gal) per minute, in order to avoid air locks.

Cooling system air locks may result in engine damage.

2. Fill the cooling system with Commercial Heavy-Duty Coolant. Add Supplemental Coolant Additive to the coolant. For the correct amount, refer to the Operation and Maintenance Manual, "Fluid Recommendations" topic (Maintenance Section) for more information on cooling system specifications. Do not install the cooling system filler cap.

3. Start and run the engine at low idle. Increase the engine rpm to high idle. Operate the engine in order to open the engine thermostat. This procedure will allow any air in the system to be purged. Decrease the engine speed to low idle. Stop the engine.
 4. Maintain the coolant level at the maximum mark that is correct for your application.
-

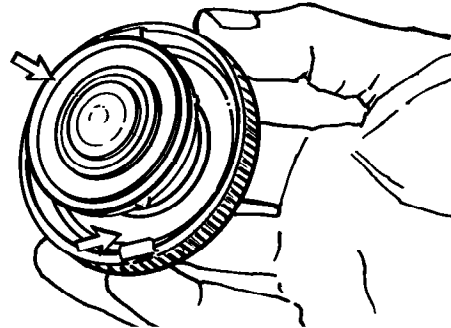

Illustration 43

g00103639

Filler cap

5. Clean the cooling system filler cap and inspect the gasket. If the gasket is damaged, discard the old filler cap and install a new filler cap. If the gasket is not damaged, use a suitable pressurizing pump in order to pressure test the filler cap. The correct pressure is stamped on the face of the filler cap. If the filler cap does not retain the correct pressure, install a new filler cap.
6. Start the engine. Inspect the cooling system for leaks and for correct operating temperature.

i04007109

Cooling System Coolant (ELC) - Change

NOTICE

Care must be taken to ensure that fluids are contained during performance of inspection, maintenance, testing, adjusting and repair of the product. Be prepared to collect the fluid with suitable containers before opening any compartment or disassembling any component containing fluids.

Dispose of all fluids according to Local regulations and mandates.

NOTICE

Keep all parts clean from contaminants.

Contaminants may cause rapid wear and shortened component life.

Clean the cooling system and flush the cooling system before the recommended maintenance interval if the following conditions exist:

- The engine overheats frequently.
- Foaming of the coolant is observed.
- The oil has entered the cooling system and the coolant is contaminated.
- The fuel has entered the cooling system and the coolant is contaminated.

Note: When the cooling system is cleaned, only clean water is needed when the ELC is drained and replaced.

Note: Inspect the water pump and the water temperature regulator after the cooling system has been drained. This inspection is a good opportunity to replace the water pump, the water temperature regulator, and the hoses, if necessary.

NOTICE

When any servicing or repair of the engine cooling system is performed, the procedure must be performed with the engine on level ground. This procedure will allow you to accurately check the coolant level. This procedure will also help in avoiding the risk of introducing an air lock into the coolant system.

Drain**WARNING**

Pressurized System: Hot coolant can cause serious burns. To open the cooling system filler cap, stop the engine and wait until the cooling system components are cool. Loosen the cooling system pressure cap slowly in order to relieve the pressure.

1. Stop the engine and allow the engine to cool. Loosen the cooling system filler cap slowly in order to relieve any pressure. Remove the cooling system filler cap.

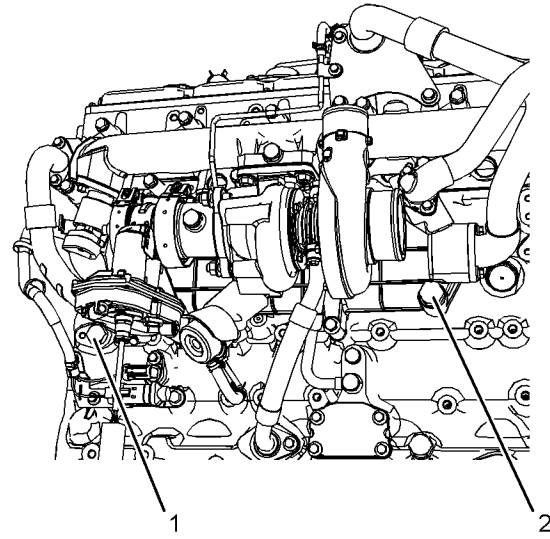

Illustration 44

g02177998

2. Open the drain cock or remove the drain plug (1) on the engine. Also remove the drain plug (2). Open the drain cock or remove the drain plug on the radiator.

Note: There are two drain plugs on the cooler, only one is required for draining.

Allow the coolant to drain.

NOTICE

Dispose of used engine coolant or recycle. Various methods have been proposed to reclaim used coolant for reuse in engine cooling systems. The full distillation procedure is the only method acceptable by Perkins to reclaim the coolant.

For information regarding the disposal and the recycling of used coolant, consult your Perkins dealer or your Perkins distributor.

Flush

1. Flush the cooling system with clean water in order to remove any debris.
2. Close the drain cock or install the drain plugs. Close the drain cock or install the drain plug on the radiator.

NOTICE

Do not fill the cooling system faster than 5 L (1.3 US gal) per minute, in order to avoid air locks.

Cooling system air locks may result in engine damage.

Maintenance Section
Cooling System Coolant Level - Check

3. Fill the cooling system with clean water. Install the cooling system filler cap.
4. Start and run the engine at low idle until the temperature reaches 49 to 66 °C (120 to 150 °F).
5. Stop the engine and allow the engine to cool. Loosen the cooling system filler cap slowly in order to relieve any pressure. Remove the cooling system filler cap. Open the drain cock or remove the drain plug on the engine. Open the drain cock or remove the drain plug on the radiator. Allow the water to drain. Flush the cooling system with clean water.

Fill

1. Close the drain cock or install the drain plug on the engine. Close the drain cock or install the drain plug on the radiator.

NOTICE

Do not fill the cooling system faster than 5 L (1.3 US gal) per minute, in order to avoid air locks.

Cooling system air locks may result in engine damage.

2. Fill the cooling system with Extended Life Coolant (ELC). Refer to the Operation and Maintenance Manual, "Fluid Recommendations" topic (Maintenance Section) for more information on cooling system specifications. Do not install the cooling system filler cap.
3. Start and run the engine at low idle. Increase the engine rpm to high idle. Operate the engine in order to open the engine thermostat. Operate the engine will allow any air in the system to be purged. Decrease the engine speed to low idle. Stop the engine.
4. Maintain the coolant level at the maximum mark that is correct for your application.

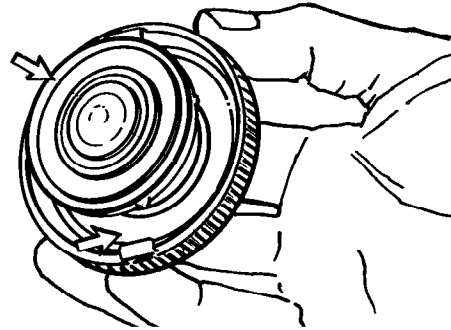

Illustration 45

g00103639

Filler cap

5. Clean the cooling system filler cap and inspect the gasket. If the gasket is damaged, discard the old filler cap and install a new filler cap. If the gasket is not damaged, use a suitable pressurizing pump in order to test the pressure of the filler cap. The correct pressure is stamped on the face of the filler cap. If the filler cap does not retain the correct pressure, install a new filler cap.
6. Start the engine. Inspect the cooling system for leaks and for correct operating temperature.

i04408743

Cooling System Coolant Level - Check

Engines With a Coolant Recovery Tank

Note: The cooling system may not have been provided by Perkins. The procedure that follows is for typical cooling systems. Refer to the OEM information for the correct procedures.

Check the coolant level when the engine is stopped and cool.

NOTICE

When any servicing or repair of the engine cooling system is performed, the procedure must be performed with the engine on level ground. This will allow you to accurately check the coolant level. This will also help in avoiding the risk of introducing an air lock into the coolant system.

1. Observe the coolant level in the coolant recovery tank. Maintain the coolant level to "COLD FULL" mark on the coolant recovery tank.

⚠ WARNING

Pressurized System: Hot coolant can cause serious burns. To open the cooling system filler cap, stop the engine and wait until the cooling system components are cool. Loosen the cooling system pressure cap slowly in order to relieve the pressure.

2. Loosen filler cap slowly in order to relieve any pressure. Remove the filler cap.
3. Pour the correct coolant mixture into the tank. Refer to the Operation and Maintenance Manual, "Refill Capacities and Recommendations" for information on the correct mixture and type of coolant. Refer to the Operation and Maintenance Manual, "Refill Capacities and Recommendations" for the cooling system capacity. Do not fill the coolant recovery tank above "COLD FULL" mark.

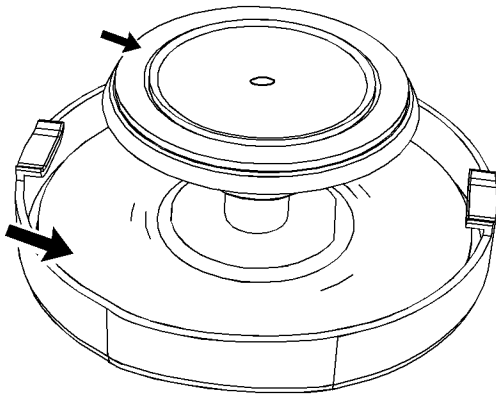

Illustration 46

g02590196

Filler cap

4. Clean filler cap and the receptacle. Reinstall the filler cap and inspect the cooling system for leaks.

Note: The coolant will expand as the coolant heats up during normal engine operation. The additional volume will be forced into the coolant recovery tank during engine operation. When the engine is stopped and cool, the coolant will return to the engine.

Engines Without a Coolant Recovery Tank

Check the coolant level when the engine is stopped and cool.

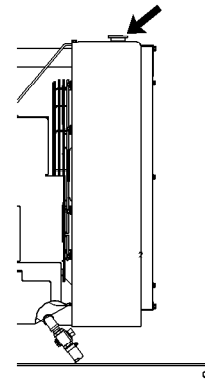

Illustration 47

g00285520

Cooling system filler cap

⚠ WARNING

Pressurized System: Hot coolant can cause serious burns. To open the cooling system filler cap, stop the engine and wait until the cooling system components are cool. Loosen the cooling system pressure cap slowly in order to relieve the pressure.

1. Remove the cooling system filler cap slowly in order to relieve pressure.
2. Maintain the coolant level at the maximum mark that is correct for your application. If the engine is equipped with a sight glass, maintain the coolant level to the correct level in the sight glass.
3. Clean the cooling system filler cap and inspect the gasket. If the gasket is damaged, discard the old filler cap and install a new filler cap. If the gasket is not damaged, use a suitable pressurizing pump in order to pressure test the filler cap. The correct pressure is stamped on the face of the filler cap. If the filler cap does not retain the correct pressure, install a new filler cap.

4. Inspect the cooling system for leaks.

i03644948

Cooling System Supplemental Coolant Additive (SCA) - Test/Add

WARNING

Cooling system coolant additive contains alkali. To help prevent personal injury, avoid contact with the skin and the eyes. Do not drink cooling system coolant additive.

Test for SCA Concentration

Heavy-Duty Coolant/Antifreeze and SCA

NOTICE

Do not exceed the recommended six percent supplemental coolant additive concentration.

Use a Coolant Conditioner Test Kit in order to check the concentration of the SCA.

Add the SCA, If Necessary

NOTICE

Do not exceed the recommended amount of supplemental coolant additive concentration. Excessive supplemental coolant additive concentration can form deposits on the higher temperature surfaces of the cooling system, reducing the engine's heat transfer characteristics. Reduced heat transfer could cause cracking of the cylinder head and other high temperature components. Excessive supplemental coolant additive concentration could also result in radiator tube blockage, overheating, and/or accelerated water pump seal wear. Never use both liquid supplemental coolant additive and the spin-on element (if equipped) at the same time. The use of those additives together could result in supplemental coolant additive concentration exceeding the recommended maximum.

WARNING

Pressurized System: Hot coolant can cause serious burns. To open the cooling system filler cap, stop the engine and wait until the cooling system components are cool. Loosen the cooling system pressure cap slowly in order to relieve the pressure.

NOTICE

When any servicing or repair of the engine cooling system is performed the procedure must be performed with the engine on level ground. This will allow you to accurately check the coolant level. This will also help in avoiding the risk of introducing an air lock into the coolant system.

1. Slowly loosen the cooling system filler cap in order to relieve the pressure. Remove the cooling system filler cap.

Note: Always discard drained fluids according to local regulations.

2. If necessary, drain some coolant from the cooling system into a suitable container in order to allow space for the extra SCA.

3. Add the correct amount of SCA. Refer to the Operation and Maintenance Manual, "Refill Capacities and Recommendations" for more information on SCA requirements.

4. Clean the cooling system filler cap and inspect the gasket. If the gasket is damaged, discard the old filler cap and install a new filler cap. If the gasket is not damaged, use a suitable pressurizing pump in order to pressure test the filler cap. The correct pressure is stamped on the face of the filler cap. If the filler cap does not retain the correct pressure, install a new filler cap.

i02151646

Driven Equipment - Check

Refer to the OEM specifications for more information on the following maintenance recommendations for the driven equipment:

- Inspection
- Adjustment
- Lubrication
- Other maintenance recommendations

Perform any maintenance for the driven equipment which is recommended by the OEM.

i07819515

Engine - Clean

WARNING

Personal injury or death can result from high voltage.

Moisture can create paths of electrical conductivity.

Make sure that the electrical system is OFF. Lock out the starting controls and tag the controls "DO NOT OPERATE" .

NOTICE

Accumulated grease and oil on an engine is a fire hazard. Keep the engine clean. Remove debris and fluid spills whenever a significant quantity accumulates on the engine.

Periodic cleaning of the engine is recommended. Steam cleaning the engine will remove accumulated oil and grease. A clean engine provides the following benefits:

- Easy detection of fluid leaks
- Maximum heat transfer characteristics
- Ease of maintenance

Note: Caution must be used to prevent electrical components from being damaged by excessive water when the engine is cleaned. Pressure washers and steam cleaners should not be directed at any electrical connectors or the junction of cables into the rear of the connectors. Avoid electrical components such as the alternator, the starter, and the ECM. Protect the fuel injection pump from fluids to wash the engine.

Ensure that care is taken that the safety labels, emission label, and all other information labels are not removed during engine cleaning.

Aftertreatment

During the engine cleaning process, ensure that water or cleaning fluids cannot enter the aftertreatment system. If cleaning fluids enters the aftertreatment system, damage could occur.

i02334355

Engine Air Cleaner Element (Dual Element) - Clean/Replace

NOTICE

Never run the engine without an air cleaner element installed. Never run the engine with a damaged air cleaner element. Do not use air cleaner elements with damaged pleats, gaskets or seals. Dirt entering the engine causes premature wear and damage to engine components. Air cleaner elements help to prevent airborne debris from entering the air inlet.

NOTICE

Never service the air cleaner element with the engine running since this will allow dirt to enter the engine.

Servicing the Air Cleaner Elements

Note: The air filter system may not have been provided by Perkins. The procedure that follows is for a typical air filter system. Refer to the OEM information for the correct procedure.

If the air cleaner element becomes plugged, the air can split the material of the air cleaner element. Unfiltered air will drastically accelerate internal engine wear. Refer to the OEM information for the correct air cleaner elements for your application.

- Check the precleaner (if equipped) and the dust bowl daily for accumulation of dirt and debris. Remove any dirt and debris, as needed.
- Operating in dirty conditions may require more frequent service of the air cleaner element.
- The air cleaner element should be replaced at least one time per year. This replacement should be performed regardless of the number of cleanings.

Replace the dirty air cleaner elements with clean air cleaner elements. Before installation, the air cleaner elements should be thoroughly checked for tears and/or holes in the filter material. Inspect the gasket or the seal of the air cleaner element for damage. Maintain a supply of suitable air cleaner elements for replacement purposes.

Dual Element Air Cleaners

The dual element air cleaner contains a primary air cleaner element and a secondary air cleaner element.

The primary air cleaner element can be used up to six times if the element is properly cleaned and properly inspected. The primary air cleaner element should be replaced at least one time per year. This replacement should be performed regardless of the number of cleanings.

The secondary air cleaner element is not serviceable. Refer to the OEM information for instructions in order to replace the secondary air cleaner element.

When the engine is operating in environments that are dusty or dirty, air cleaner elements may require more frequent replacement.

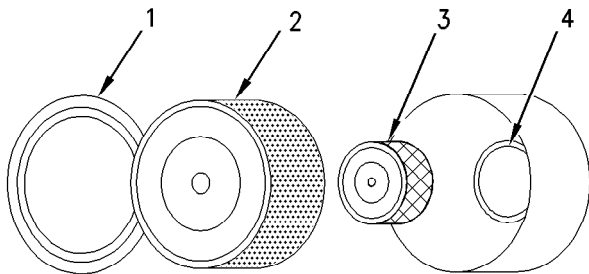

Illustration 48

g00736431

- (1) Cover
 (2) Primary air cleaner element
 (3) Secondary air cleaner element
 (4) Air inlet

1. Remove the cover. Remove the primary air cleaner element.
2. The secondary air cleaner element should be removed and discarded for every three cleanings of the primary air cleaner element.

Note: Refer to “Cleaning the Primary Air Cleaner Elements”.

3. Cover the air inlet with tape in order to keep dirt out.
4. Clean the inside of the air cleaner cover and body with a clean, dry cloth.
5. Remove the tape from the air inlet. Install the secondary air cleaner element. Install a primary air cleaner element that is new or cleaned.
6. Install the air cleaner cover.

7. Reset the air cleaner service indicator.

Cleaning the Primary Air Cleaner Elements

Refer to the OEM information in order to determine the number of times that the primary filter element can be cleaned. When the primary air cleaner element is cleaned, check for rips or tears in the filter material. The primary air cleaner element should be replaced at least one time per year. This replacement should be performed regardless of the number of cleanings.

NOTICE

Do not tap or strike the air cleaner element.

Do not wash the primary air cleaner element.

Use low pressure (207 kPa; 30 psi maximum) pressurized air or vacuum cleaning to clean the primary air cleaner element.

Take extreme care in order to avoid damage to the air cleaner elements.

Do not use air cleaner elements that have damaged pleats, gaskets or seals.

Refer to the OEM information in order to determine the number of times that the primary air cleaner element can be cleaned. Do not clean the primary air filter element more than three times. The primary air cleaner element must be replaced at least one time per year.

Cleaning the air filter element will not extend the life of the air filter element.

Visually inspect the primary air cleaner element before cleaning. Inspect air cleaner elements for damage to the pleats, the seals, the gaskets and the outer cover. Discard any damaged air cleaner element.

Two methods may be used in order to clean the primary air cleaner element:

- pressurized air
- Vacuum cleaning

Pressurized Air

WARNING

Personal injury can result from air pressure.

Personal injury can result without following proper procedure. When using pressure air, wear a protective face shield and protective clothing.

Maximum air pressure at the nozzle must be less than 205 kPa (30 psi) for cleaning purposes.

Pressurized air can be used to clean primary air cleaner elements that have not been cleaned more than three times. Use filtered, dry air with a maximum pressure of 207 kPa (30 psi). Pressurized air will not remove deposits of carbon and oil.

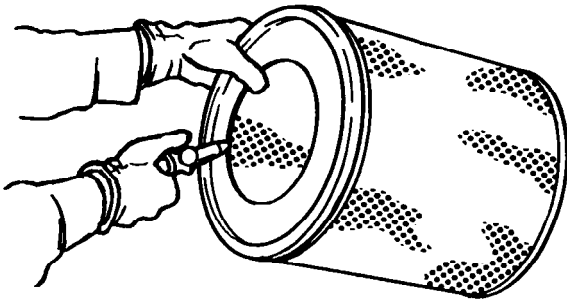

Illustration 49

g00281692

Note: When the primary air cleaner elements are cleaned, always begin with the clean side (inside) in order to force dirt particles toward the dirty side (outside).

Aim the air hose so that air flows along the length of the filter. Follow the direction of the paper pleats in order to prevent damage to the pleats. Do not aim the air directly at the face of the paper pleats.

Note: Refer to “Inspecting the Primary Air Cleaner Elements”.

Vacuum Cleaning

Vacuum cleaning is a good method for removing accumulated dirt from the dirty side (outside) of a primary air cleaner element. Vacuum cleaning is especially useful for cleaning primary air cleaner elements which require daily cleaning because of a dry, dusty environment.

Cleaning from the clean side (inside) with pressurized air is recommended prior to vacuum cleaning the dirty side (outside) of a primary air cleaner element.

Note: Refer to “Inspecting the Primary Air Cleaner Elements”.

Inspecting the Primary Air Cleaner Elements

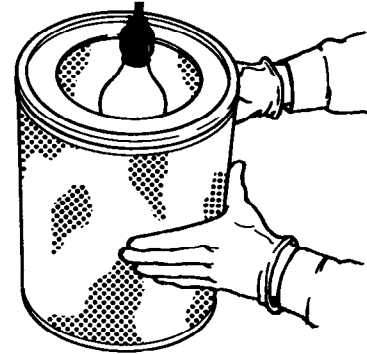

Illustration 50

g00281693

Inspect the clean, dry primary air cleaner element. Use a 60 watt blue light in a dark room or in a similar facility. Place the blue light in the primary air cleaner element. Rotate the primary air cleaner element. Inspect the primary air cleaner element for tears and/or holes. Inspect the primary air cleaner element for light that may show through the filter material. If it is necessary in order to confirm the result, compare the primary air cleaner element to a new primary air cleaner element that has the same part number.

Do not use a primary air cleaner element that has any tears and/or holes in the filter material. Do not use a primary air cleaner element with damaged pleats, gaskets or seals. Discard damaged primary air cleaner elements.

i02152042

Engine Air Cleaner Element (Single Element) - Inspect/Replace

Refer to Operation and Maintenance Manual, “Engine Air Cleaner Service Indicator-Inspect”.

NOTICE

Never run the engine without an air cleaner element installed. Never run the engine with a damaged air cleaner element. Do not use air cleaner elements with damaged pleats, gaskets or seals. Dirt entering the engine causes premature wear and damage to engine components. Air cleaner elements help to prevent airborne debris from entering the air inlet.

NOTICE

Never service the air cleaner element with the engine running since this will allow dirt to enter the engine.

A wide variety of air cleaners may be installed for use with this engine. Consult the OEM information for the correct procedure to replace the air cleaner.

i02335405

Engine Air Cleaner Service Indicator - Inspect

Some engines may be equipped with a different service indicator.

Some engines are equipped with a differential gauge for inlet air pressure. The differential gauge for inlet air pressure displays the difference in the pressure that is measured before the air cleaner element and the pressure that is measured after the air cleaner element. As the air cleaner element becomes dirty, the pressure differential rises. If your engine is equipped with a different type of service indicator, follow the OEM recommendations in order to service the air cleaner service indicator.

The service indicator may be mounted on the air cleaner element or in a remote location.

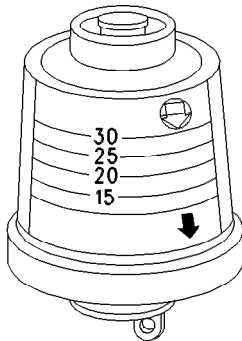

Illustration 51

g00103777

Typical service indicator

Observe the service indicator. The air cleaner element should be cleaned or the air cleaner element should be replaced when one of the following conditions occur:

- The yellow diaphragm enters the red zone.
- The red piston locks in the visible position.

Test the Service Indicator

Service indicators are important instruments.

- Check for ease of resetting. The service indicator should reset in less than three pushes.
- Check the movement of the yellow core when the engine is accelerated to the engine rated speed. The yellow core should latch at the greatest vacuum that is attained.

If the service indicator does not reset easily, or if the yellow core does not latch at the greatest vacuum, the service indicator should be replaced. If the new service indicator will not reset, the hole for the service indicator may be restricted.

The service indicator may need to be replaced frequently in environments that are severely dusty.

i05967804

Engine Air Precleaner - Check/Clean (If Equipped)

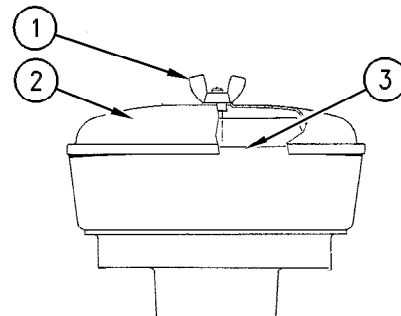

Illustration 52

g00287039

Typical example

- (1) Wing nut
- (2) Cover
- (3) Body

Remove wing nut (1) and cover (2). Check for an accumulation of dirt and debris in body (3). Clean the body, if necessary.

After cleaning the pre-cleaner, install cover (2) and wing nut (1).

Note: When the engine is operated in dusty applications, more frequent cleaning is required.

i08410458

Engine Crankcase Breather Element - Replace (Type 1)

WARNING

Hot oil and hot components can cause personal injury. Do not allow hot oil or hot components to contact the skin.

NOTICE

Ensure that the engine is stopped before any servicing or repair is performed.

NOTICE

Care must be taken to ensure that fluids are contained during performance of inspection, maintenance, testing, adjusting and repair of the product. Be prepared to collect the fluid with suitable containers before opening any compartment or disassembling any component containing fluids.

Dispose of all fluids according to Local regulations and mandates.

The crankcase breather is a very important component to keep your engine emissions compliant.

- The filter element within the crankcase breather must be serviced at the prescribed service interval.
- The correct filter element must be installed before the engine is operated.
- The installation of the filter element is very important.
- The quality of the filter element that is installed is very important.
- The filter element protects the engine from excessive quantities of oil from entering the induction system. The filter element also protects the engine aftertreatment system.

Note: Excessive quantities of oil that enter the induction system of the engine can rapidly increase the engine speed without control.

For information on aftermarket products, refer to Operation and Maintenance Manual, "Engine Description". Within that section, refer to the title "Aftermarket Products and Perkins Engines".

The breather element can be serviced from the top position or the breather element can be serviced from the bottom position.

Top Service

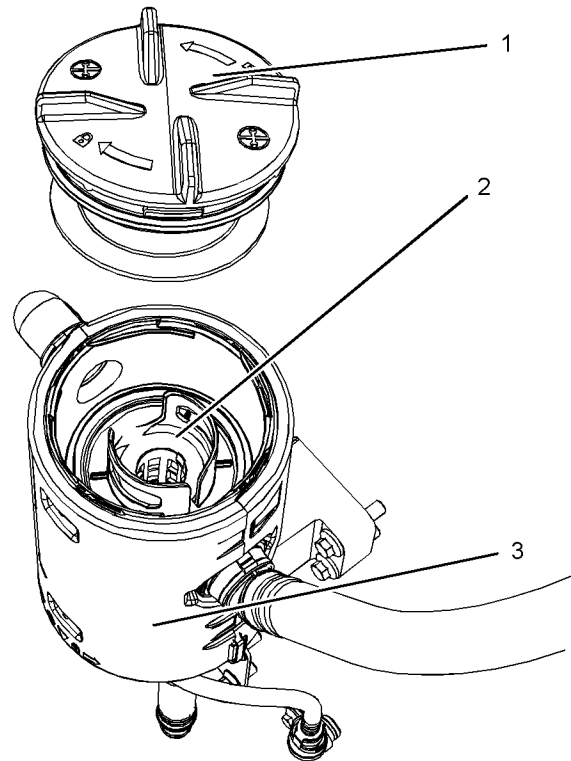

Illustration 53

g03090965

1. Ensure that dirt cannot enter the breather assembly. Ensure that the outside body of the breather assembly is clean and free from damage. Place a container under the breather assembly.
2. Rotate the top cap (1) counterclockwise into the unlocked position. Remove the top cap from the body of the breather (3).

Note: The cap (1) is tightened or loosened by hand. If the cap (1) is difficult to remove, use a suitable tool to apply a suitable force to assist the removal of the cap (1). Care should be taken, as excessive force may cause damage to the cap (1).

3. Note the orientation of the filter element (2). Remove the filter element.

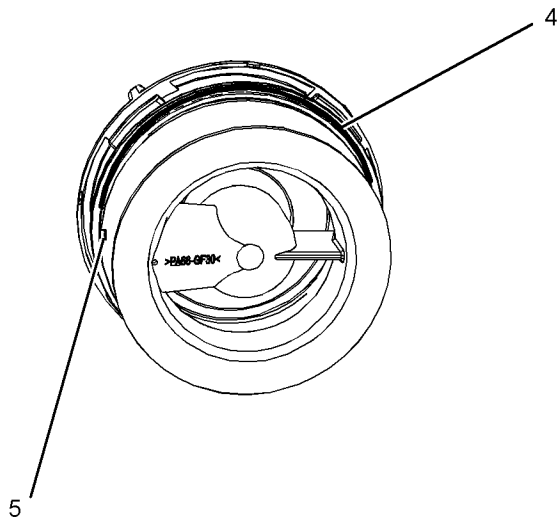

Illustration 54

g03090963

Typical example

4. Remove the old seal (4) and install a new seal.

Note: The cut away from section (5) in the top cap allows access to the seal.

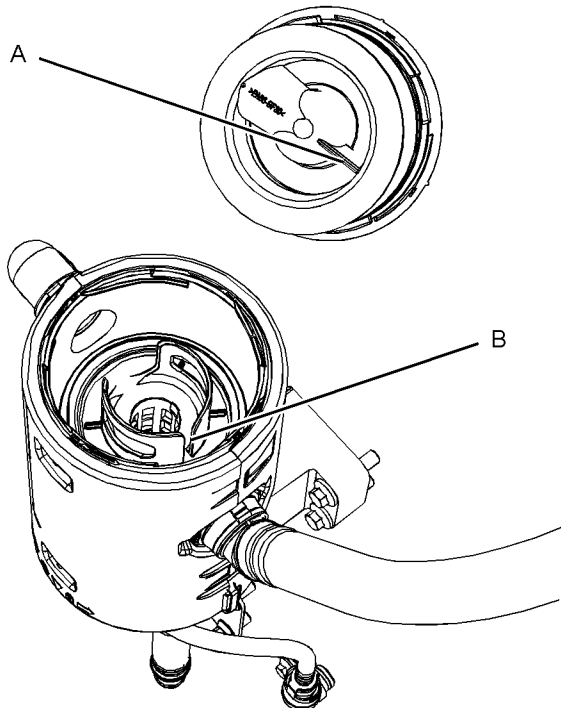

Illustration 55

g03090938

(A) Alignment position
(B) Alignment position

5. Install a new filter element into the breather body (3). Ensure the correct position of the element, refer to illustration 55. Align position (A) on the top cap to position (B) on the filter element.

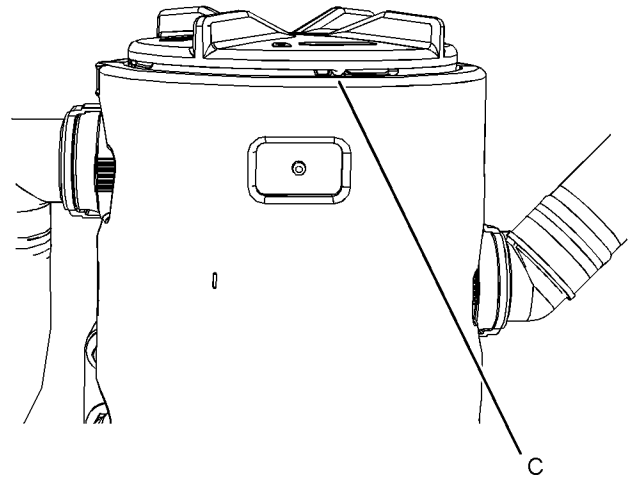

Illustration 56

g02346577

Typical example

6. Install the top cap (1). Rotate the top cap by hand clockwise until the top cap locks into the locked position (C) on the breather body.

7. Remove the container.

Bottom Service

Ensure that dirt cannot enter the breather assembly.

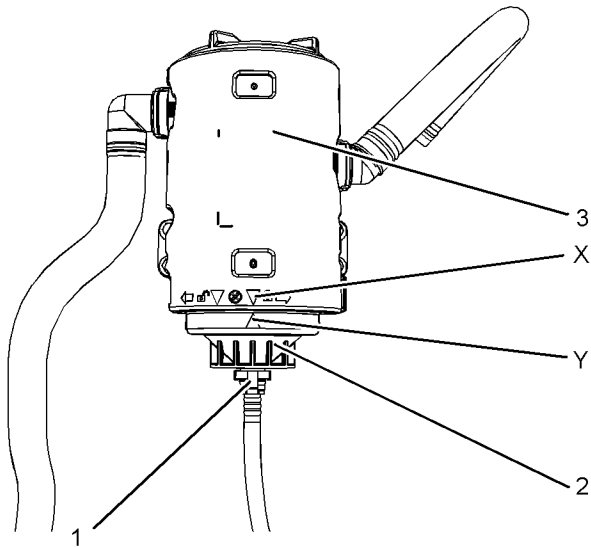

Illustration 57

g02346498

Typical example

(X) Alignment mark
(Y) Alignment mark

1. Ensure that the outside body of the breather assembly is clean and free from damage. Place a container under the breather.
2. Remove the tube connection (1). Ensure that dirt cannot enter the tube connection. Note the position of the alignment marks (X and Y). Rotate the bottom cap (2) counterclockwise to release the cap and the filter element (4) from the breather body (3).

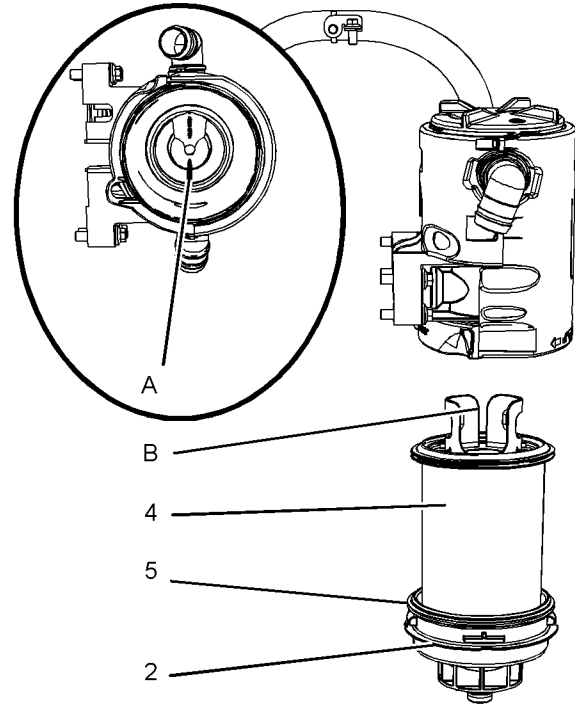

Illustration 58

g03090968

Typical example

(A) Alignment position
(B) Alignment position

3. Note the orientation of the filter element. Remove the filter element (4) from the bottom cap (2). Remove the seal (5).

Note: The bottom cap has a section that allows access to remove the seal.

4. Install a new seal (5). Install a new filter element into the bottom cap (2).
5. Align position (A) on the top cap to position (B) on the filter element. Refer to illustration 58 .
6. Install the assembly of the filter element and the bottom cap (2). Rotate the bottom cap by hand clockwise until the bottom cap locks into the locked position on the breather body. Ensure that the alignment marks (X and Y) are correctly aligned. Refer to illustration 57 .

Maintenance Section
Engine Crankcase Breather Element - Replace

7. Install tube connection (1). Ensure that the retaining clips on the tube connection are correctly engaged. Remove the container.

Check the System

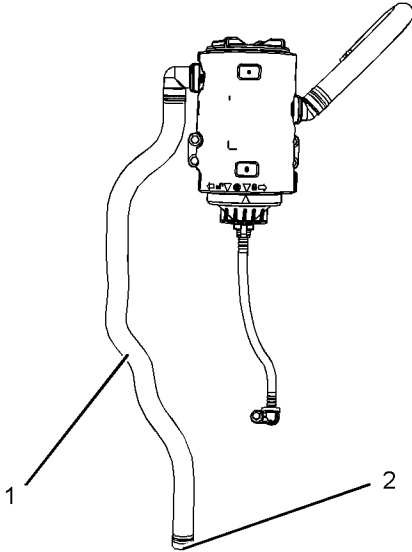

Illustration 59

g02346500

Typical example

Inspect the breather tube (1) for damage. Ensure that the outlet (2) is clean and free from any obstructions. Ice can cause obstructions in adverse weather conditions.

i08421031

Engine Crankcase Breather Element - Replace (Type 2)

⚠ WARNING

Hot oil and hot components can cause personal injury. Do not allow hot oil or hot components to contact the skin.

NOTICE

Ensure that the engine is stopped before any servicing or repair is performed.

The crankcase breather is a very important component in order to keep your engine emissions compliant.

- The filter element within the crankcase breather must be serviced at the prescribed service interval.
- The correct filter element must be installed before the engine is operated.
- The installation of the filter element is very important.
- The quality of the filter element that is installed is very important.
- The filter element protects the engine from excessive quantities of oil from entering the induction system. The filter element also protects the engine aftertreatment system.

Note: Excessive quantities of oil that enter the induction system of the engine can rapidly increase the engine speed without control.

For information on aftermarket products, refer to Operation and Maintenance Manual, "Engine Description". Within that section, refer to the title "Aftermarket Products and Perkins Engines".

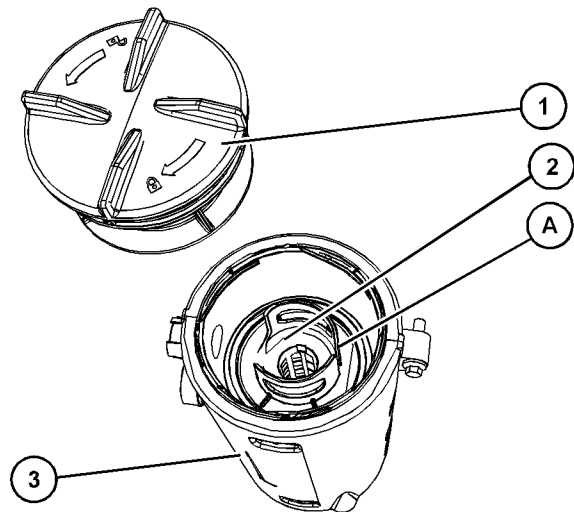

Illustration 60

g06623961

Typical example

1. Ensure that dirt cannot enter the breather assembly. Ensure that the outside body of the breather assembly is clean and free from damage. Place a container under the breather assembly.
2. Rotate the cap (1) counterclockwise into the unlocked position. Remove the cap from the body of the breather (3).

Note: The cap (1) is tightened or loosened by hand. If the cap (1) is difficult to remove, use a suitable tool to apply a suitable force to assist the removal of the cap (1). Care should be taken, as excessive force may cause damage to the cap (1).

- Note the orientation of the filter element (2).
Remove the filter element .

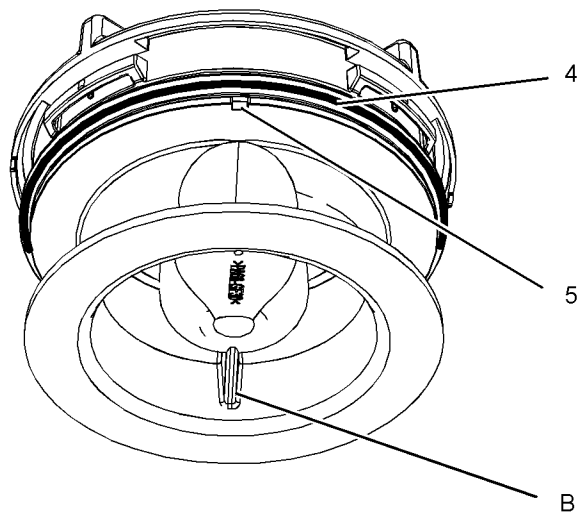

Illustration 61 g01884135
(B) Alignment position

Note: The cut away from section (5) in the cap allows access to the seal.

- Remove the old seal (4) and install a new seal.
- Install a new filter element into the breather body (3) and orient the filter element so that position (A) is aligned. Refer to illustration 60 . Align position (A) on the filter element to position (B) on the cap.

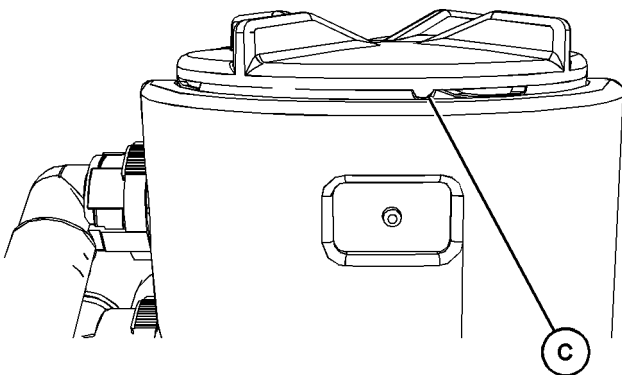

Illustration 62 g06623944
Typical example

- Install the cap (1). Rotate the cap by hand clockwise until the cap locks into the locked position C on the breather body.
- Remove the container.

Check the System

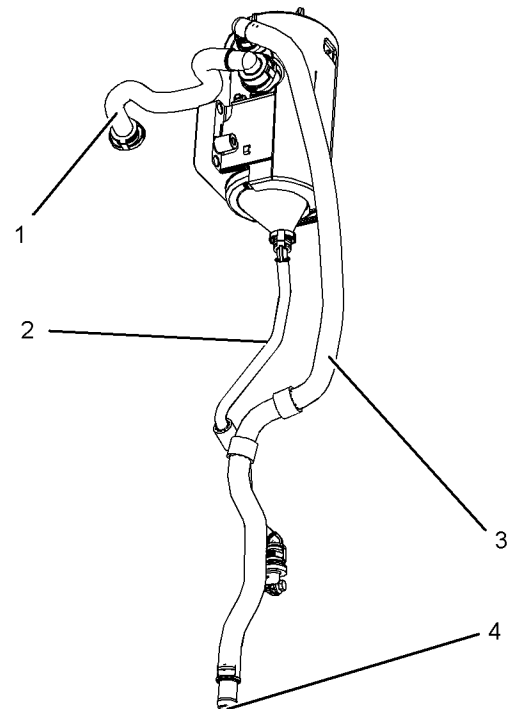

Illustration 63 g02416001
(1) Connection to breather cap for the engine
(2) Oil drain
(3) Tube assembly to atmosphere
(4) Outlet

Check the system for damage. Replace any component that is damaged. Ensure that the outlet (4) is clear and free from obstructions.

i07819538

Engine Mounts - Inspect

Note: The engine mounts may not have been supplied by Perkins. Refer to the Original Equipment Manufacturer (OEM) information for further details on the engine mounts and the correct bolt torque.

Inspect the engine mounts for deterioration and for correct bolt torque. Excessive engine vibration can be caused by the following conditions:

- Incorrect mounting of the engine

Maintenance Section
Engine Oil Level - Check

- Deterioration of the engine mounts
- Loose engine mounts

Any engine mount that shows deterioration should be replaced. Refer to the OEM information for the recommended torques.

When the engine mounts are supplied by Perkins the maintenance procedure will be supplied in the Disassembly and Assembly manual for your engine.

i05300117

Engine Oil Level - Check

i01907674

WARNING

Hot oil and hot components can cause personal injury. Do not allow hot oil or hot components to contact the skin.



Illustration 64

g02173847

"L" Low

"H" High

NOTICE

Perform this maintenance with the engine stopped.

Note: Ensure that the engine is either level or that the engine is in the normal operating position in order to obtain a true level indication.

Note: After the engine has been switched OFF, wait for 10 minutes in order to allow the engine oil to drain to the oil pan before checking the oil level.

1. Maintain the oil level between the mark (L) and the mark (H) on the engine oil dipstick. Do not fill the crankcase above the "H" .

NOTICE

Operating your engine when the oil level is above the "H" mark could cause your crankshaft to dip into the oil. The air bubbles created from the crankshaft dipping into the oil reduces the oils lubricating characteristics and could result in the loss of power.

2. Remove the oil filler cap and add oil, if necessary. Clean the oil filler cap. Install the oil filler cap.

If an increase in the oil level is noticed, refer to Troubleshooting, "Oil Contains Fuel".

Engine Oil Sample - Obtain

The condition of the engine lubricating oil may be checked at regular intervals as part of a preventive maintenance program. Perkins include an oil sampling valve as an option. The oil sampling valve (if equipped) is included in order to regularly sample the engine lubricating oil. The oil sampling valve is positioned on the oil filter head or the oil sampling valve is positioned on the cylinder block.

Perkins recommends using a sampling valve in order to obtain oil samples. The quality and the consistency of the samples are better when a sampling valve is used. The location of the sampling valve allows oil that is flowing under pressure to be obtained during normal engine operation.

Obtain the Sample and the Analysis

WARNING

Hot oil and hot components can cause personal injury. Do not allow hot oil or hot components to contact the skin.

In order to help obtain the most accurate analysis, record the following information before an oil sample is taken:

- The date of the sample
- Engine model
- Engine number
- Service hours on the engine
- The number of hours that have accumulated since the last oil change
- The amount of oil that has been added since the last oil change

Ensure that the container for the sample is clean and dry. Also ensure that the container for the sample is clearly labelled.

To ensure that the sample is representative of the oil in the crankcase, obtain a warm, well mixed oil sample.

To avoid contamination of the oil samples, the tools and the supplies that are used for obtaining oil samples must be clean.

The sample can be checked for the following: the quality of the oil, the existence of any coolant in the oil, the existence of any ferrous metal particles in the oil and the existence of any nonferrous metal particles in the oil.

i04021983

Engine Oil and Filter - Change

WARNING

Hot oil and hot components can cause personal injury. Do not allow hot oil or hot components to contact the skin.

NOTICE

Care must be taken to ensure that fluids are contained during performance of inspection, maintenance, testing, adjusting and repair of the product. Be prepared to collect the fluid with suitable containers before opening any compartment or disassembling any component containing fluids.

Dispose of all fluids according to local regulations and mandates.

NOTICE

Keep all parts clean from contaminants.

Contaminants may cause rapid wear and shortened component life.

Do not drain the engine lubricating oil when the engine is cold. As the engine lubricating oil cools, suspended waste particles settle on the bottom of the oil pan. The waste particles are not removed with draining cold oil. Drain the oil pan with the engine stopped. Drain the oil pan with the oil warm. This draining method allows the waste particles that are suspended in the oil to be drained properly.

Failure to follow this recommended procedure will cause the waste particles to be recirculated through the engine lubrication system with the new oil.

Drain the Engine Lubricating Oil

Note: Ensure that the vessel that will be used is large enough to collect the waste oil.

After the engine has been run at the normal operating temperature, stop the engine. Use one of the following methods to drain the engine oil pan:

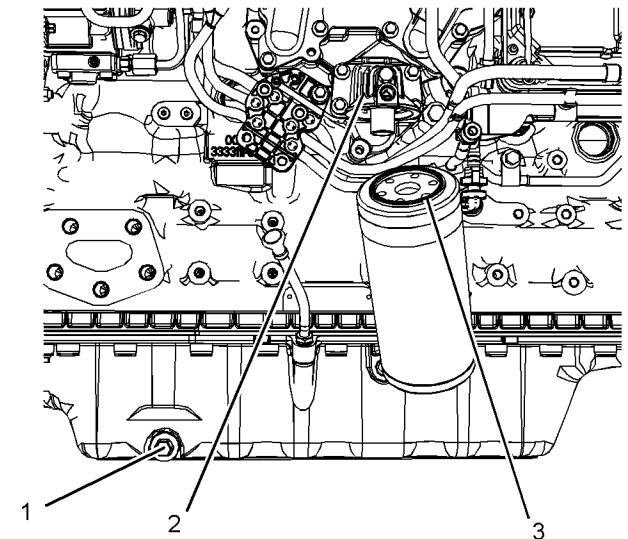

Illustration 65

g02178063

Typical example

- If the engine is equipped with a drain valve, turn the drain valve knob counterclockwise in order to drain the oil. After the oil has drained, turn the drain valve knob clockwise in order to close the drain valve.
- If the engine is not equipped with a drain valve, remove the oil drain plug (1) in order to allow the oil to drain. If the engine is equipped with a shallow oil pan, remove the bottom oil drain plugs from both ends of the oil pan.

After the oil has drained, the oil drain plugs should be cleaned and installed. If necessary, replace the O ring seal. Tighten the drain plug to 34 N·m (25 lb ft).

Replace the Oil Filter

NOTICE

Perkins oil filters are manufactured to Perkins specifications. Use of an oil filter that is not recommended by Perkins could result in severe damage to the engine bearings, crankshaft, etc., as a result of the larger waste particles from unfiltered oil entering the engine lubricating system. Only use oil filters recommended by Perkins.

Maintenance Section
Fuel System - Prime

1. Place a suitable container below the oil filter assembly. Remove the oil filter with a suitable tool.
2. Clean sealing surface of the oil filter base (2).
3. Apply clean engine oil to O ring seal (3) for the new oil filter.

NOTICE

Do not fill the oil filters with oil before installing them. This oil would not be filtered and could be contaminated. Contaminated oil can cause accelerated wear to engine components.

4. Install the new oil filter. Spin on the oil filter until the O ring contacts the sealing surface (2). Then rotate the oil filter $\frac{3}{4}$ of a full turn.

Fill the Oil Pan

1. Remove the oil filler cap. Refer to this Operation and Maintenance Manual, "Fluid Recommendations" for more information on suitable oils. Fill the oil pan with the correct amount of new engine lubricating oil. Refer to this Operation and Maintenance Manual, "Refill Capacities" for more information on refill capacities.

NOTICE

If equipped with an auxiliary oil filter system or a remote filter system, follow the OEM or the filter manufacturer's recommendations. Under filling or over filling the crankcase with oil can cause engine damage.

2. Start the engine and run the engine at "LOW IDLE" for 2 minutes. Perform this procedure in order to ensure that the lubrication system has oil and that the oil filters are filled. Inspect the oil filter for oil leaks.
3. Stop the engine and allow the oil to drain back to the oil pan for a minimum of 10 minutes.



Illustration 66

g02173847

4. Remove the engine oil level gauge in order to check the oil level. Maintain the oil level between the "L" and "H" marks on the engine oil level gauge. Do not fill the crankcase above the "H" mark.

i05774864

Fuel System - Prime

Note: Refer to Systems Operation, Testing, and Adjusting, "Cleanliness of Fuel System Components" for detailed information on the standards of cleanliness that must be observed during ALL work on the fuel system.

Ensure that all adjustments and repairs are performed by authorized personnel that have had the correct training.

NOTICE

Do not crank the engine continuously for more than 30 seconds. Allow the starting motor to cool for two minutes before cranking the engine again.

If air enters the fuel system, the air must be purged from the fuel system before the engine can be started. Air can enter the fuel system when the following events occur:

- The fuel tank is empty or the fuel tank has been partially drained.
- The low-pressure fuel lines are disconnected.
- A leak exists in the low-pressure fuel system.
- The fuel filter has been replaced.

Use the following procedures in order to remove air from the fuel system:

1. Ensure that the fuel system is in working order. Check that the fuel supply valve (if equipped) is in the "ON" position.
2. Turn the keyswitch to the "RUN" position.
3. The keyswitch will allow the electric priming pump to operate. Operate the electric priming pump. The ECM will stop the pump after 2 minutes.
4. Turn the keyswitch to the "OFF" position. The fuel system should now be primed and the engine should be able to start.
5. Operate the engine starter and crank the engine. After the engine has started, operate the engine at low idle for a minimum of 5 minutes. Ensure that the fuel system is free from leaks.

Note: Operating the engine for this period will help ensure that the fuel system is free of air. **DO NOT loosen the high-pressure fuel lines in order to purge air from the fuel system. This procedure is not required.**

After the engine has stopped, you must wait for 10 minutes in order to allow the fuel pressure to be purged from the high-pressure fuel lines before any service or repair is performed on the engine fuel lines. The 10 minute wait will also allow static charge to dissipate from the low-pressure fuel system. If necessary, perform minor adjustments. Repair any leaks from the low-pressure fuel system and from the cooling, lubrication, or air systems. Replace any high-pressure fuel line that has leaked. Refer to Disassembly and Assembly Manual, "Fuel Injection Lines - Install".

If you inspect the engine in operation, always use the proper inspection procedure in order to avoid a fluid penetration hazard. Refer to Operation and Maintenance Manual, "General hazard Information".

If the engine will not start, refer to Troubleshooting, "Engine Cranks but will not Start".

i09722465

Fuel System Primary Filter (Water Separator) Element - Replace

WARNING

Fuel leaked or spilled onto hot surfaces or electrical components can cause a fire. To help prevent possible injury, turn the start switch off when changing fuel filters or water separator elements. Clean up fuel spills immediately.

Note: Refer to Systems Operation, Testing, and Adjusting, "Cleanliness of Fuel System Components" for detailed information on the standards of cleanliness that must be observed during ALL work on the fuel system.

NOTICE

Ensure that the engine is stopped before any servicing or repair is performed.

NOTICE

Engines that operate under severe conditions will require more frequent maintenance intervals to ensure maximum reliability. Engine performance may be impacted if the application is operated at altitudes greater than 3000m or with fuel that is not of the correct specification as detailed in "Fluid Recommendations" (General Fuel Information) of this OMM. It is recommended that new fuel filters are installed every 250 service hours in severe operating conditions. For more information consult your Perkins distributor.

Remove the Element

1. Turn the fuel supply valve (if equipped) to the OFF position before performing this maintenance.
2. Place a suitable container under the water separator to catch any fuel that might spill. Clean up any spilled fuel. Clean the outside body of the filter assembly.
3. Make a temporary Mark (A) across the filter before the assembly is removed.

Maintenance Section
 Fuel System Primary Filter (Water Separator) Element - Replace

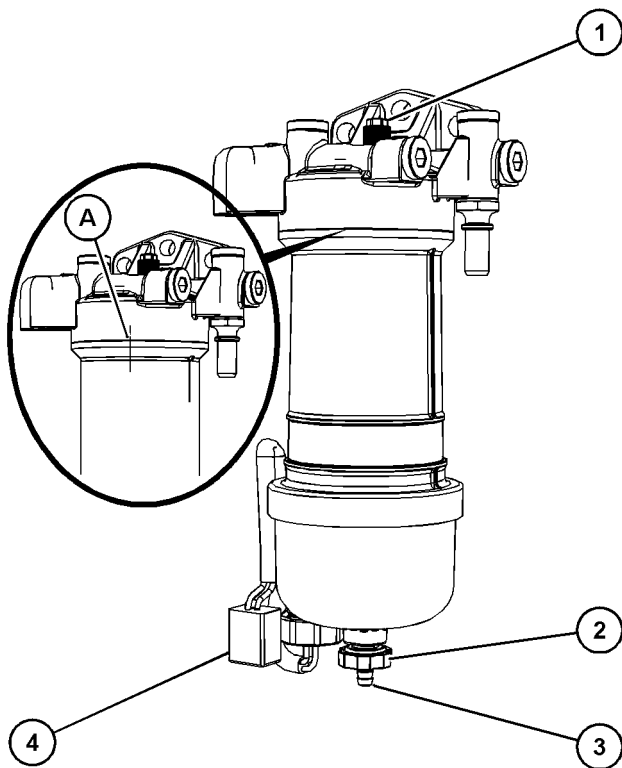

Illustration 67

g07565358

Typical example

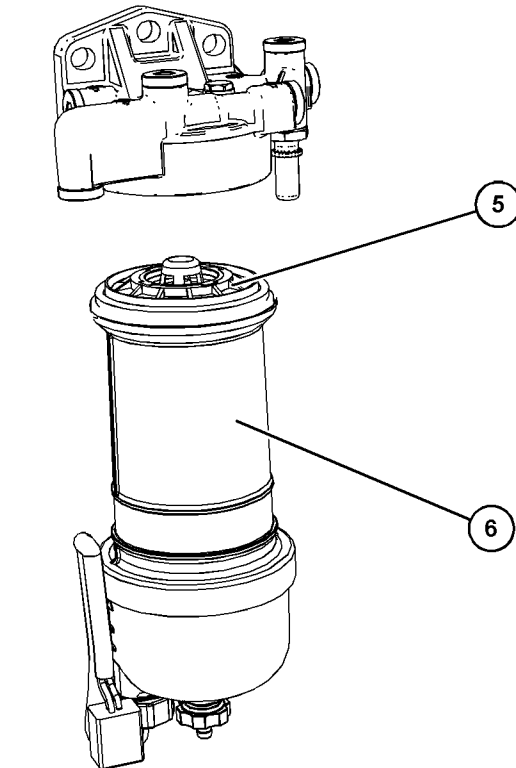

Illustration 68

g07555800

Typical example

4. Install a suitable tube onto drain (3). Open the drain valve (2). Rotate the drain valve counterclockwise. Two full turns are required. Loosen vent screw (1).

Note: Two complete rotations of the valve will release the valve from the filter element.

5. Allow the fuel to drain into the container. Remove the tube and install the valve into the filter element. Engage the threads of the valve into the filter element. Do not secure the valve.
6. Tighten the vent screw (1) securely. Remove the wiring harness from connection (4).
7. Remove the filter bowl (6). Rotate the filter assembly counterclockwise to remove the filter assembly. Use a suitable tool to remove the filter assembly.

8. Rotate the filter element counterclockwise and remove the filter element (5). Clean the filter bowl.

Install the Element

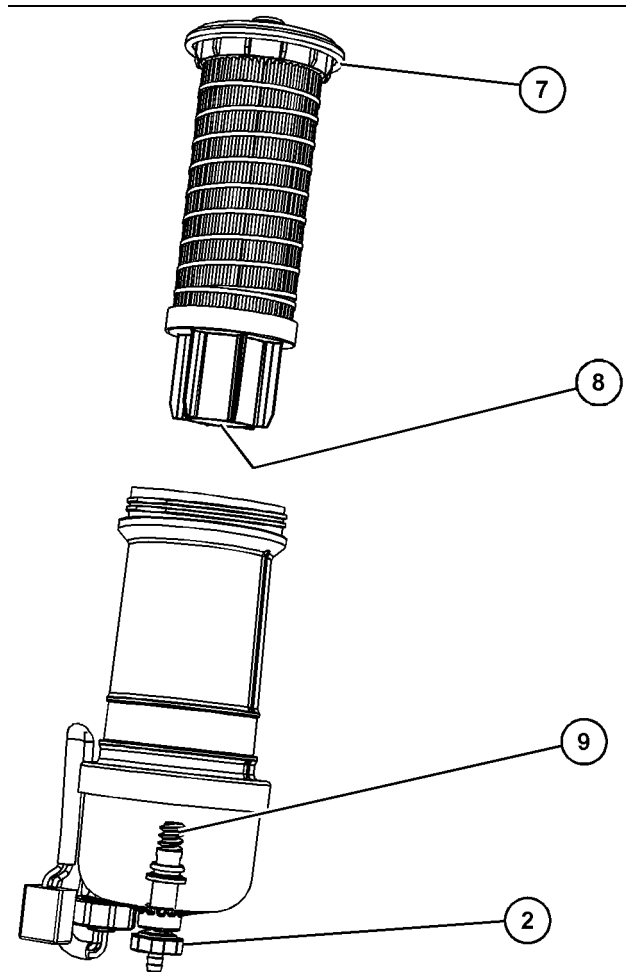

Illustration 69

g07555815

Typical example

1. Locate the thread in the filter element (8) onto the threads (9). Spin on the element. Do not tighten.
 2. Lubricate the O ring seal (7) with clean diesel fuel. Do NOT fill the bowl with fuel before the assembly is installed.
 3. Do not use a tool to install the filter assembly. Tighten the filter bowl (6) by hand. Install the filter bowl (6) and align with your temporary marks (A).
 4. Tighten the valve (2) securely. Remove the container and dispose of the fuel in a safe place.
5. The secondary filter element must be replaced at the same time as the primary filter element. Refer to the Operation and Maintenance Manual, "Fuel System Filter - Replace".

In-line Strainer

The fuel system has an in-line strainer installed before the electric priming pump. Perkins recommended that the in-line strainer be replaced when required.

The location of the in-line strainer will depend on the application.

i03980098

Fuel System Primary Filter/ Water Separator - Drain

⚠ WARNING

Fuel leaked or spilled onto hot surfaces or electrical components can cause a fire. To help prevent possible injury, turn the start switch off when changing fuel filters or water separator elements. Clean up fuel spills immediately.

NOTICE

Ensure that the engine is stopped before any servicing or repair is performed.

NOTICE

The water separator can be under suction during normal engine operation. Ensure that the drain valve is tightened securely to help prevent air from entering the fuel system.

1. Place a suitable container under the water separator in order to catch any fluid that might spill. Clean up any spilled fluid.
2. Ensure that the outer body of the filter assembly is clean and free from dirt.

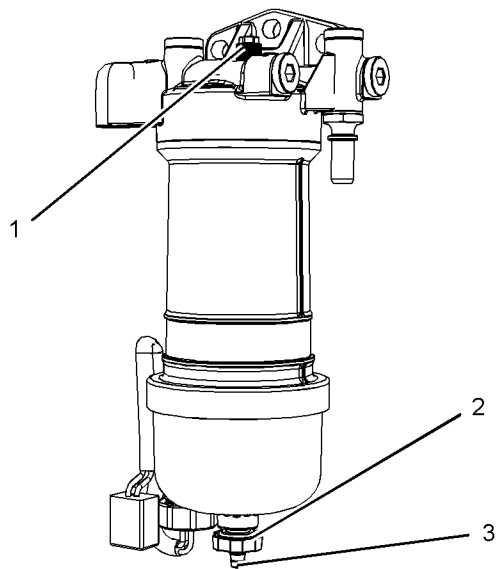

Illustration 70

g02148370

Typical example

3. Install a suitable tube onto drain (3). Open the drain valve (2). Rotate the drain valve counterclockwise. Two full turns are required. Loosen vent screw (1).

Note: Two complete rotations of the valve will release the valve from the filter element.

4. Allow the fluid to drain into the container.
5. Engage the threads of the valve into the filter element and tighten the drain valve by hand pressure only. Remove the tube and remove the container.
6. Tighten vent screw securely.

i09722477

Fuel System Secondary Filter - Replace

WARNING

Fuel leaked or spilled onto hot surfaces or electrical components can cause a fire. To help prevent possible injury, turn the start switch off when changing fuel filters or water separator elements. Clean up fuel spills immediately.

Note: Refer to Systems Operation, Testing, and Adjusting, “Cleanliness of Fuel System Components” for detailed information on the standards of cleanliness that must be observed during ALL work on the fuel system.

NOTICE

Ensure that the engine is stopped before any servicing or repair is performed.

NOTICE

Engines that operate under severe conditions will require more frequent maintenance intervals to ensure maximum reliability. Engine performance may be impacted if the application is operated at altitudes greater than 3000m or with fuel that is not of the correct specification as detailed in “Fluid Recommendations” (General Fuel Information) of this OMM. It is recommended that new fuel filters are installed every 250 service hours in severe operating conditions. For more information consult your Perkins distributor.

Remove the Element

1. Turn the fuel supply valve (if equipped) to the OFF position before performing this maintenance.
2. Place a suitable container under the fuel filter to catch any fuel that might spill. Clean up any spilled fuel. Clean the outside body of the filter assembly.

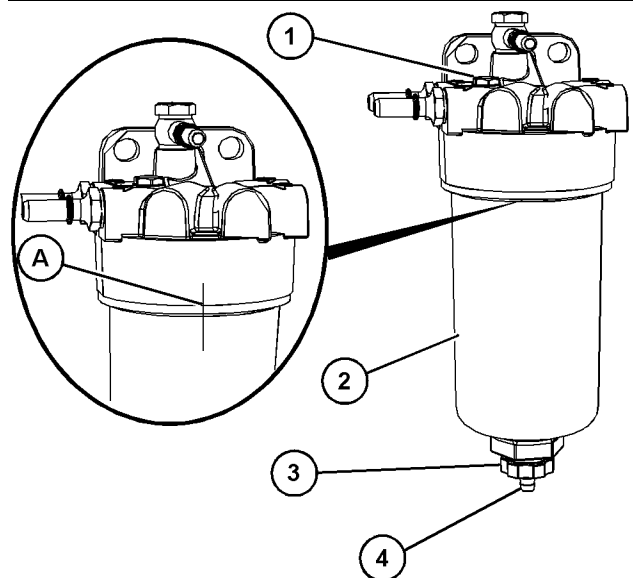

Illustration 71

g07565442

Typical example

3. Make a temporary Mark (A) across the filter before the assembly is removed. Install a suitable tube onto drain (4). Open the drain valve (3). Rotate the drain valve counterclockwise. Two full turns are required. Loosen vent screw (1).

Note: Two complete rotations of the valve will release the valve from the filter element.

4. Allow the fuel to drain into the container. Remove the tube and install the valve into the filter element. Engage the threads of the valve into the filter element. Do not secure the valve.
5. Tighten the vent screw (1) to a torque of 2.5 N·m (22 lb in).
6. Remove the filter bowl (2). Rotate the filter assembly counterclockwise to remove the assembly. Use a suitable tool to remove the filter bowl.

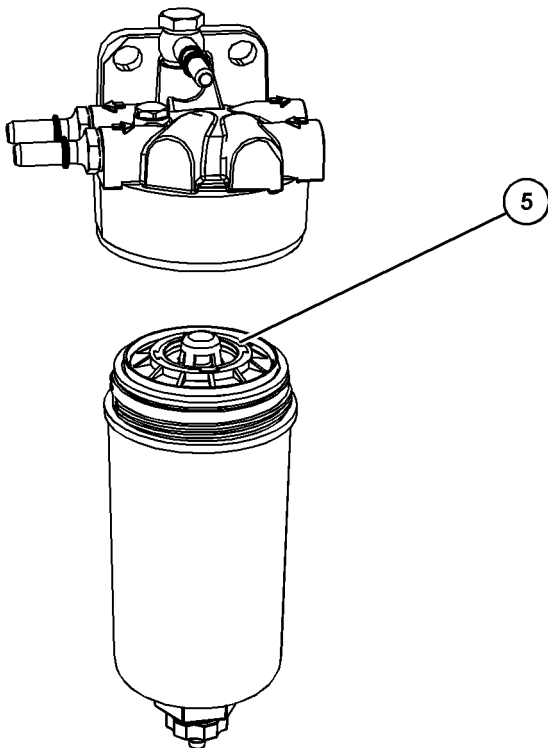

Illustration 72

g07555883

Typical example

7. Rotate the filter element counterclockwise and remove the filter element (5). Clean the filter bowl.

Install the Element

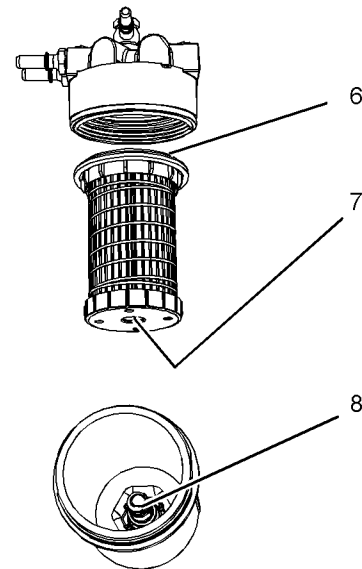

Illustration 73

g02148528

Typical example

1. Locate the thread in the filter element (7) onto the threads (8). Spin on the element. Do not tighten.
2. Lubricate the O ring seal (6) with clean diesel fuel. Do NOT fill the filter bowl (2) with fuel before the filter assembly is installed.
3. Do not use a tool to install the filter assembly. Tighten the assembly by hand. Install the filter bowl (2) and align with your temporary Marks.
4. Tighten the drain valve (3). Turn the fuel supply valve to the ON position.
5. The Primary filter element must be replaced at the same time as the secondary filter element. Refer to the Operation and Maintenance Manual, "Fuel System Primary Filter (Water Separator) Element - Replace".

6. Prime the fuel system. Refer to the Operation and Maintenance Manual, "Fuel System - Prime" for more information.

i02348492

Fuel Tank Water and Sediment - Drain

NOTICE

Care must be taken to ensure that fluids are contained during performance of inspection, maintenance, testing, adjusting and repair of the product. Be prepared to collect the fluid with suitable containers before opening any compartment or disassembling any component containing fluids.

Dispose of all fluids according to local regulations and mandates.

Fuel Tank

Fuel quality is critical to the performance and to the service life of the engine. Water in the fuel can cause excessive wear to the fuel system.

Water can be introduced into the fuel tank when the fuel tank is being filled.

Condensation occurs during the heating and cooling of fuel. The condensation occurs as the fuel passes through the fuel system and the fuel returns to the fuel tank. This causes water to accumulate in fuel tanks. Draining the fuel tank regularly and obtaining fuel from reliable sources can help to eliminate water in the fuel.

Drain the Water and the Sediment

Fuel tanks should contain some provision for draining water and draining sediment from the bottom of the fuel tanks.

Open the drain valve on the bottom of the fuel tank in order to drain the water and the sediment. Close the drain valve.

Check the fuel daily. Allow five minutes after the fuel tank has been filled before draining water and sediment from the fuel tank.

Fill the fuel tank after operating the engine in order to drive out moist air. This will help prevent condensation. Do not fill the tank to the top. The fuel expands as the fuel gets warm. The tank may overflow.

Some fuel tanks use supply pipes that allow water and sediment to settle below the end of the fuel supply pipe. Some fuel tanks use supply lines that take fuel directly from the bottom of the tank. If the engine is equipped with this system, regular maintenance of the fuel system filter is important.

Fuel Storage Tanks

Drain the water and the sediment from the fuel storage tank at the following intervals:

- Weekly
- Service intervals
- Refill of the tank

This will help prevent water or sediment from being pumped from the storage tank into the engine fuel tank.

If a bulk storage tank has been refilled or moved recently, allow adequate time for the sediment to settle before filling the engine fuel tank. Internal baffles in the bulk storage tank will also help trap sediment. Filtering fuel that is pumped from the storage tank helps to ensure the quality of the fuel. When possible, water separators should be used.

i07819616

Hoses and Clamps - Inspect/Replace

 **WARNING**

Contact with high pressure fuel may cause fluid penetration and burn hazards. High pressure fuel spray may cause a fire hazard. Failure to follow these inspection, maintenance and service instructions may cause personal injury or death.

If you inspect the engine in operation, always use the proper inspection procedure to avoid a fluid penetration hazard. Refer to Operation and Maintenance Manual, "General hazard Information" and Operation and Maintenance Manual, "High Pressure Fuel Lines" for the correct procedures.

Inspect all hoses for leaks that are caused by the following conditions:

- Cracking
- Softness
- Loose clamps

Replace hoses that are cracked or soft. Tighten any loose clamps.

Check for the following conditions:

- End fittings that are damaged or leaking
- Outer covering that is chafed or cut
- Exposed wire that is used for reinforcement
- Outer covering that is ballooning locally
- Flexible part of the hose that is kinked or crushed
- Armoring that is embedded in the outer covering

A constant torque hose clamp can be used in place of any standard hose clamp. Ensure that the constant torque hose clamp is the same size as the standard clamp.

Due to extreme temperature changes, the hose will harden. Hardening of the hoses will cause hose clamps to loosen. This can result in leaks. A constant torque hose clamp will help to prevent loose hose clamps.

Each installation application can be different. The differences depend on the following factors:

- Type of hose
- Type of fitting material
- Anticipated expansion and contraction of the hose
- Anticipated expansion and contraction of the fittings

Replace the Hoses and the Clamps

Refer to the OEM information for further information on removing and replacing fuel hoses (if equipped).

The following text describes a typical method of replacing coolant hoses. Refer to the OEM information for further information on the coolant system and the hoses for the coolant system.

WARNING

Pressurized System: Hot coolant can cause serious burns. To open the cooling system filler cap, stop the engine and wait until the cooling system components are cool. Loosen the cooling system pressure cap slowly in order to relieve the pressure.

1. Stop the engine. Allow the engine to cool.
2. Loosen the cooling system filler cap slowly to relieve any pressure. Remove the cooling system filler cap.

Note: Drain the coolant into a suitable, clean container. The coolant can be reused.

3. Drain the coolant from the cooling system to a level that is below the hose that is being replaced.
 4. Remove the hose clamps.
 5. Disconnect the old hose.
 6. Replace the old hose with a new hose.
 7. Install the hose clamps with a torque wrench.
- Note:** For the correct coolant, see this Operation and Maintenance Manual, "Fluid Recommendations".
8. Refill the cooling system. Refer to the OEM information for further information on refilling the cooling system.
 9. Clean the cooling system filler cap. Inspect the cooling system filler cap's seals. Replace the cooling system filler cap if the seals are damaged. Install the cooling system filler cap.
 10. Start the engine. Inspect the cooling system for leaks.

i09722753

Radiator - Clean

The radiator is not usually supplied by Perkins. The following text describes a typical cleaning procedure for the radiator. Refer to the OEM information for further information on cleaning the radiator.

Note: Some application will require a fuel cooler to be installed. The fuel cooler is a type of radiator that uses air to cool the fuel and the fuel cooler will require cleaning.

Note: Adjust the frequency of cleaning according to the effects of the operating environment.

Inspect the radiator for these items: Damaged fins, corrosion, dirt, grease, insects, leaves, oil, and other debris. Clean the radiator, if necessary.

WARNING

Personal injury can result from air pressure.

Personal injury can result without following proper procedure. When using pressure air, wear a protective face shield and protective clothing.

Maximum air pressure at the nozzle must be less than 205 kPa (30 psi) for cleaning purposes.

Maintenance Section
Severe Service Application - Check

Pressurized air is the preferred method for removing loose debris. Direct the air in the opposite direction to the fans air flow. Hold the nozzle approximately 6 mm (0.25 inch) away from the radiator fins. Slowly move the air nozzle in a direction that is parallel with the radiator tube assembly. The pressurized air will remove debris that is between the tubes.

Pressurized water may also be used for cleaning. The maximum water pressure for cleaning purposes must be less than 275 kPa (40 psi). Use pressurized water to soften mud. Clean the core from the front and the rear.

Use a degreaser and steam for removal of oil and grease. Clean the front and the rear of the core. Wash the core with detergent and hot water. Thoroughly rinse the core with clean water.

If the radiator is blocked internally, refer to the OEM Manual for information regarding flushing the cooling system.

After cleaning the radiator, start the engine. Allow the engine to operate at low idle speed for 3 to 5 minutes. Accelerate the engine to high idle. The high idle speed will help in the removal of debris and the drying of the core. Slowly reduce the engine speed to low idle and then stop the engine. Use a light bulb behind the core to inspect the core for cleanliness. Repeat the cleaning, if necessary.

Inspect the fins for damage. Bent fins may be opened with a "comb". Inspect these items for good condition: Welds, mounting brackets, air lines, connections, clamps, and seals. Make repairs, if necessary.

i02335775

Severe Service Application - Check

Severe service is the application of an engine that exceeds the current published standards for that engine. Perkins maintains standards for the following engine parameters:

- Performance such as power range, speed range, and fuel consumption
- Fuel quality
- Operational Altitude
- Maintenance intervals
- Oil selection and maintenance
- Coolant type and maintenance
- Environmental qualities
- Installation

- The temperature of the fluid in the engine

Refer to the standards for the engine or consult your Perkins dealer or your Perkins distributor in order to determine if the engine is operating within the defined parameters.

Severe service operation can accelerate component wear. Engines that operate under severe conditions may need more frequent maintenance intervals in order to ensure maximum reliability and retention of full service life.

Due to individual applications, it is not possible to identify all of the factors which can contribute to severe service operation. Consult your Perkins dealer or your Perkins distributor for the unique maintenance that is necessary for the engine.

The operating environment, incorrect operating procedures and incorrect maintenance procedures can be factors which contribute to a severe service application.

Environmental Factors

Ambient temperatures – The engine may be exposed to extended operation in extremely cold environments or hot environments. Valve components can be damaged by carbon buildup if the engine is frequently started and stopped in very cold temperatures. Extremely hot intake air reduces engine performance.

Quality of the air – The engine may be exposed to extended operation in an environment that is dirty or dusty, unless the equipment is cleaned regularly. Mud, dirt and dust can encase components. Maintenance can be very difficult. The buildup can contain corrosive chemicals.

Buildup – Compounds, elements, corrosive chemicals and salt can damage some components.

Altitude – Problems can arise when the engine is operated at altitudes that are higher than the intended settings for that application. Necessary adjustments should be made.

Incorrect Operating Procedures

- Extended operation at low idle
- Frequent hot shutdowns
- Operating at excessive loads
- Operating at excessive speeds
- Operating outside the intended application

Incorrect Maintenance Procedures

- Extending the maintenance intervals

- Failure to use recommended fuel, lubricants and coolant/antifreeze

i07888480

Starting Motor - Inspect

Perkins recommends a scheduled inspection of the starting motor. If the starting motor fails, the engine may not start in an emergency situation.

Check the starting motor for correct operation. Check the electrical connections and clean the electrical connections. Refer to the Systems Operation, Testing and Adjusting Manual, "Electric Starting System - Test" for more information on the checking procedure and for specifications consult your Perkins dealer or your Perkins distributor for assistance.

i04287011

Turbocharger - Inspect

WARNING

Hot engine components can cause injury from burns. Before performing maintenance on the engine, allow the engine and the components to cool.

NOTICE

Turbocharger bearing failures can cause large quantities of oil to enter the air intake and exhaust systems. Loss of engine lubricant can result in serious engine damage.

Minor leakage of oil into a turbocharger under extended low idle operation should not cause problems as long as a turbocharger bearing failure has not occurred.

If a turbocharger failure is suspected do not operate the engine. A failure of the turbocharger can be signaled by significant loss of engine performance and erratic RPM at no load. Also, large quantities of engine oil could pass into the engine air intake. This oil would have been seen as smoke from the engine exhaust. Applications that have a DPF installed will filter the engine exhaust.

A visual inspection of the turbocharger or turbochargers can minimize unscheduled downtime. A visual inspection of the turbocharger or turbochargers can also reduce the chance for potential damage to other engine parts. Do not inspect the engine with the engine in operation.

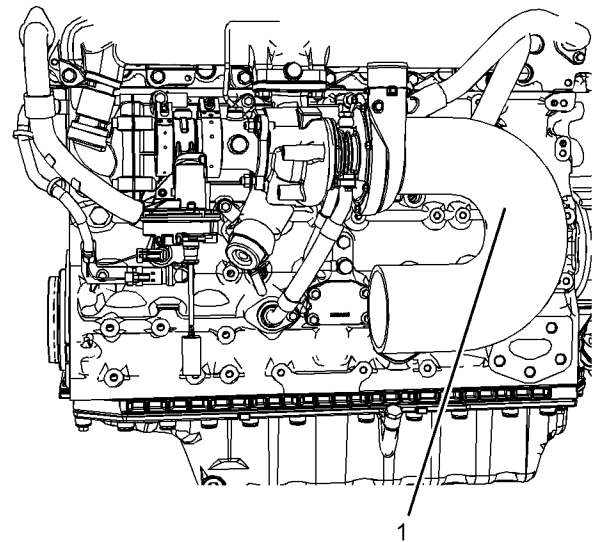

Illustration 74

g02178129

Typical example

1. Ensure that the turbocharger is clean and free from dirt before removing components for inspection.
2. Remove the pipe from the turbocharger exhaust outlet and remove the air intake pipe (1). Visually inspect the piping for the presence of oil. Clean the interior of the pipes in order to prevent dirt from entering during reassembly.
3. Check for abnormal heat discoloration of the turbocharger. Check for any loose bolts or any missing bolts. Check for damage to the oil supply line and the oil drain line. Check for cracks in the housing of the turbocharger. Ensure that the compressor wheel can rotate freely. Check for signs of damage to the compressor wheel, or contact of the compressor wheel to the body of the compressor housing.
4. Check for the presence of oil. If oil is leaking from the back side of the compressor wheel, there is a possibility of a failed turbocharger oil seal.

The presence of oil may be the result of extended engine operation at low idle. The presence of oil may also be the result of a restriction of the line for the intake air (clogged air filters), which causes the turbocharger to slobber. For more information, refer to Systems Operation, Testing, and Adjusting, "Turbocharger - Inspect".

i04156712

Walk-Around Inspection

Inspect the Tube of the Crankcase Breather

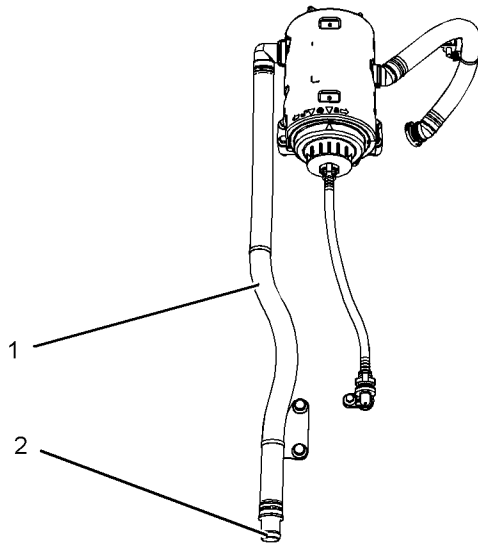

Illustration 75

g02351425

Typical example

Inspect the breather tube (1) for damage. Ensure that the outlet (2) is clean and free from any obstructions. Ice can cause obstructions in adverse weather conditions.

Inspect the Engine for Leaks and for Loose Connections

A walk-around inspection should only take a few minutes. When the time is taken to perform these checks, costly repairs and accidents can be avoided.

For maximum engine service life, make a thorough inspection of the engine compartment before starting the engine. Look for items such as oil leaks or coolant leaks, loose bolts, worn belts, loose connections, and trash buildup. Make repairs, as needed:

- The guards must be in the correct place. Repair damaged guards or replace missing guards.
- Wipe all caps and plugs before the engine is serviced in order to reduce the chance of system contamination.

NOTICE

For any type of leak (coolant, lube, or fuel) clean up the fluid. If leaking is observed, find the source and correct the leak. If leaking is suspected, check the fluid levels more often than recommended until the leak is found or fixed, or until the suspicion of a leak is proved to be unwarranted.

NOTICE

Accumulated grease and/or oil on an engine is a fire hazard. Remove the accumulated grease and oil. Refer to this Operation and Maintenance Manual, "Engine - Clean" for more information.

- Ensure that the cooling system hoses are correctly clamped and that the cooling system hoses are tight. Check for leaks. Check the condition of all pipes.

- Inspect the water pump for coolant leaks.

Note: The water pump seal is lubricated by the coolant in the cooling system. It is normal for a small amount of leakage to occur as the engine cools down and the parts contract.

Excessive coolant leakage may indicate the need to replace the water pump. Remove the water pump. Refer to Disassembly and Assembly, "Water Pump - Remove and Install". For more information, consult your Perkins dealer or your Perkins distributor.

- Inspect the lubrication system for leaks at the front crankshaft seal, the rear crankshaft seal, the oil pan, the oil filters, and the rocker cover.
- Inspect the piping for the air intake system and the elbows for cracks and for loose clamps. Ensure that hoses and tubes are not contacting other hoses, tubes, wiring harnesses, etc.
- Ensure that the areas around the rotating parts are clear.
- Inspect the alternator belts and any accessory drive belts for cracks, breaks, or other damage.
- Inspect the wiring harness for damage.

Belts for multiple groove pulleys must be replaced as matched sets. If only one belt is replaced, the belt will carry more load than the belts that are not replaced. The older belts are stretched. The additional load on the new belt could cause the belt to break.

High Pressure Fuel Lines

WARNING

Contact with high pressure fuel may cause fluid penetration and burn hazards. High pressure fuel spray may cause a fire hazard. Failure to follow these inspection, maintenance and service instructions may cause personal injury or death.

After the engine has stopped, you must wait for 10 minutes in order to allow the fuel pressure to be purged from the high-pressure fuel lines before any service or repair is performed on the engine fuel lines. If necessary, perform minor adjustments. Repair any leaks from the low-pressure fuel system and from the cooling, lubrication or air systems. Replace any high-pressure fuel line that has leaked. Refer to Disassembly and Assembly Manual, "Fuel Injection Lines - Install".

If you inspect the engine in operation, always use the proper inspection procedure in order to avoid a fluid penetration hazard. Refer to Operation and Maintenance Manual, "General hazard Information".

Visually inspect the high-pressure fuel lines for damage or signs of fuel leakage. Replace any damaged high-pressure fuel lines or high-pressure fuel lines that have leaked.

Ensure that all clips on the high-pressure fuel lines are in place and that the clips are not loose.

- Inspect the rest of the fuel system for leaks. Look for loose fuel line clamps.
- Drain the water and the sediment from the fuel tank on a daily basis in order to ensure that only clean fuel enters the fuel system.
- Inspect the wiring and the wiring harnesses for loose connections and for worn wires or frayed wires. Check for any loose tie-wraps or missing tie-wraps.
- Inspect the ground strap for a good connection and for good condition.
- Disconnect any battery chargers that are not protected against the current drain of the starting motor. Check the condition and the electrolyte level of the batteries, unless the engine is equipped with a maintenance free battery.

- Check the condition of the gauges. Replace any gauges that are cracked. Replace any gauge that cannot be calibrated.

i03570653

Water Pump - Inspect

A failed water pump may cause severe engine overheating problems that could result in the following conditions:

- Cracks in the cylinder head
- A piston seizure
- Other potential damage to the engine

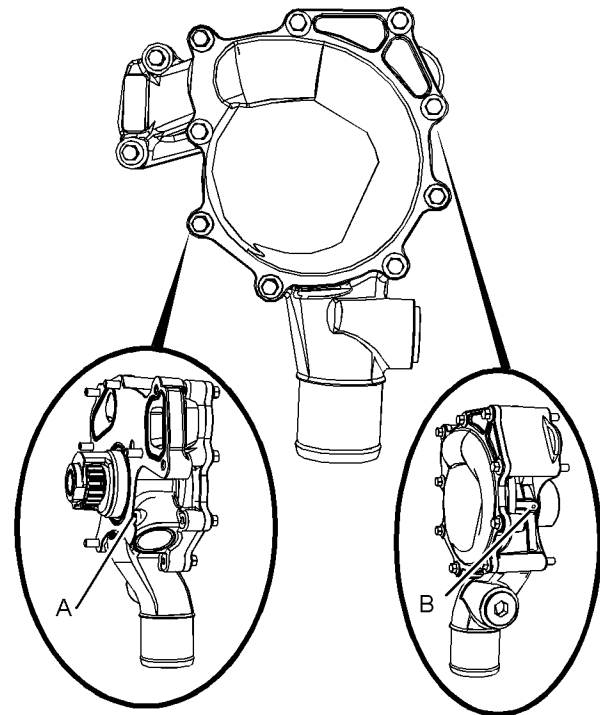

Illustration 76

g01904773

(A) Weep hole
(B) Vent hole

Note: The water pump seals are lubricated by the coolant in the cooling system. It is normal for a small amount of leakage to occur. Refer to illustration 76 for the position of the weep hole and the vent hole.

Visually inspect the water pump for leaks.

Maintenance Section
Water Pump - Inspect

Note: If engine coolant enters the engine lubricating system the lubricating oil and the engine oil filter must be replaced. This will remove any contamination that is caused by the coolant and this will prevent any irregular oil samples.

The water pump is not a serviceable item. In order to install a new water pump, refer to the Disassembly and Assembly Manual, "Water Pump - Remove and Install".

Warranty Section

Warranty Information

i04021284

Federal Emission Control Warranty

Emissions Warranty

The 1206E-E66TA diesel engine is a nonroad compression ignition engine. Perkins Engine Company limited warrants to the initial owner and to the subsequent owner of the 1206E-E66TA diesel engine that such an engine is:

1. Designed, built, and equipped so that the engine conforms, at the time of sale, with all applicable regulations adopted by the United States Environmental Protection Agency (EPA).
2. Free from defects in materials and workmanship in specific emission-related parts for the following period:
 - The warranty period is for 3000 hours or for 5 years, whichever occurs first. After the date of delivery to the owner that operates the engine.

If an emission-related part fails during any of the warranty periods, the part will be repaired or replaced. Any such part repaired or replaced under warranty is warranted for the remainder of the warranty period.

During the term of this warranty, Perkins Engine Company limited will provide through a Perkins distributor or your Perkins dealer or other establishment authorized by Perkins Engine Company limited, repair or replacement of any warranted part at no charge to the engine owner.

In an emergency, repairs may be performed at any service establishment, or by the owner, using any replacement part. Perkins recommended that emission-related parts be replaced with genuine Perkins Engine Company limited parts.

Perkins Engine Company limited will reimburse the owner. This reimbursement will include diagnostic charges for such an emergency repair. These expenses shall not exceed the Perkins Engine Company limited suggested retail price for all warranted parts replaced, and labor charges based on Perkins Engine Company limited recommended time allowance for the warranty repair and the geographically appropriate hourly labor rate.

As a condition of reimbursement, replaced parts and receipted invoices must be presented at a place of business of a Perkins distributor or your Perkins dealer. Or other establishment authorized by Perkins Engine Company limited

This warranty covers the following emission-related parts and components:

- Turbocharger System
- Inlet Manifold
- Fuel Injection System
- Crankcase Ventilation System
- Electronic Engine Control System
- Engine Aftertreatment System
- NOx Reduction System
- Aftertreatment Regeneration Device
- Miscellaneous valves, switches, hoses, clamps, connectors, tubing, and sealing devices that are used in the above systems

Limitations and Responsibilities

The warranty is subject to the following conditions:

Perkins Engine Company limited Responsibilities

During the emission warranty period, if a defect in material or workmanship of an emission-related part or component is found, Perkins Engine Company limited will provide the following:

- New, Remanufactured or repaired parts and/or components, approved pursuant to EPA Regulations, required to correct the defect.
- Reasonable and customary labor, during normal working hours that is required to make the warranty repair. This will include labor in order to remove an engine and install the engine, if necessary.

Note: Items that are replaced under this warranty become the property of Perkins Engine Company limited.

Owner Responsibilities

During the emission warranty period, the owner is responsible for the following items:

- The costs in order to investigate complaints which are not caused by a defect in Perkins Engine Company limited material or Perkins Engine Company limited workmanship.

Warranty Section
Emissions Warranty Information

- Providing timely notice of a warrantable failure and promptly making the product available for repair

Limitations

Perkins Engine Company limited is not responsible for resultant damages to an emission-related part or component resulting from the following items:

- Any application or any installation that Perkins Engine Company limited deems improper.
- Attachments, accessory items, or parts not sold nor approved by Perkins Engine Company limited
- Improper engine maintenance, repair, or abuse.
- Use of improper fuel, lubricants, or fluids.
- Owners unreasonable delay in making the product available after being notified of a potential product problem.

This warranty is in addition to Perkins Engine Company limited standard warranty, applicable to the engine product involved.

Remedies under this warranty are limited to the provision of material and services as specified herein. Perkins Engine Company limited is not responsible for incidental or consequential damages, including but not limited to downtime or loss-of-use of engine.

i04711150

Emissions Warranty Information

The aftertreatment system can be expected to function properly for the life-time of the engine (emissions durability period) subject to prescribed maintenance requirements being followed.

- EPA _____ United States Environmental Protection Agency
- CARB _____ California Air Resources Board

Note: The warranty of the engine applies to engines that are operated within the areas of the world where the following regulations apply: US EPA Tier 4 Interim, EU Stage IIIB or Japanese MLIT Step 4. If an engine is operated in regions of the world where these regulations do not apply the warranty will be void. Contact your Perkins dealer or your Perkins distributor for more information.

Maintenance Recommendations

Perkins Engines Company Limited engines are certified by the EPA and the CARB in order to comply with exhaust emission standards and gaseous emission standards that are prescribed by the law at the time of manufacture.

Efficiency of the emission control and the engine performance depends on adherence to proper operation and maintenance recommendations and use of recommended fuels and lubricating oils. According to recommendations, major adjustments and repairs should be made by your authorized Perkins distributor or your authorized Perkins dealer.

Various chemical fuel additives which claim to reduce visible smoke are available commercially. Although additives have been used to solve some isolated smoke problems in the field, additives are not recommended for general use. The engines should be certified without smoke depressants according to federal smoke regulations.

Take corrective steps immediately after worn parts which may affect the emissions level are discovered in order to ensure the proper operation of the emission control systems. The use of genuine Perkins components is recommended. If the owner uses non-Perkins components, then the non-Perkins components must not adversely affect the emissions level of the engine.

For information on the use of Aftermarket Products and Perkins Engines, refer to this Operation and Maintenance Manual, "Engine Description".

Regular maintenance intervals with a special emphasis on the following items are necessary in order to keep exhaust emissions within acceptable limits for the useful life of the engine. Refer to the Operation and Maintenance Manual, "Severe Service Application - Check" topic (Maintenance Section). If the engine is operating under severe conditions, adjust the maintenance schedule accordingly. See your authorized Perkins distributor/dealer in order to help analyze your specific application, operating environment, and maintenance schedule adjustments.

The following information is an explanation of maintenance items for emission-related components. See the Operation and Maintenance Manual, "Maintenance Interval Schedule" (Maintenance Section) for the specific interval for the following items.

ENGINE AFTERTREATMENT SYSTEM – The Engine Aftertreatment Systems are sensitive to the type of fuel and lubricants that is used. Also, the engine aftertreatment systems are sensitive to the operating schedule. Low quality fuel, lubricants, or fluids may cause increases in exhaust back pressure or clogging resulting in loss of power. An authorized Perkins distributor/dealer can determine if the engine aftertreatment systems require a service.

NOx Reduction System (NRS) – The NRS is monitored. An authorized Perkins distributor/dealer can determine if the NRS needs service.

FUEL INJECTORS – Fuel injector tips are subject to wear as a result of fuel contamination. This damage can cause the following conditions: an increase in fuel consumption, black smoke, misfire and rough running engine. The fuel injector should be inspected, tested, and replaced, if necessary. Fuel injectors can be tested by an authorized Perkins distributor/dealer.

TURBOCHARGER – Refer to this Operation and Maintenance Manual, “Turbocharger - Inspect” for information on inspection of the turbocharger.

ELECTRONIC ENGINE CONTROL (ECM) – The ECM is the control computer of the engine. The ECM provides power to the electronics. The ECM monitors data that is input from the sensors of the engine. The ECM acts as a governor in order to control the speed and the power of the engine. The ECM adjusts injection timing and fuel pressure for the best engine performance, the best fuel economy, and the best control of exhaust emissions.

Erratic behavior of the engine may indicate a need for repair to the ECM. Your Perkins distributor/dealer is equipped with the necessary tools, personnel, and procedures in order to perform this service.

The owner is encouraged to keep adequate maintenance records. However, the absence of such records will not invalidate the warranty. Refer to the Operation and Maintenance Manual, “Maintenance Log” (Reference Materials Section).

The owner may perform routine maintenance, repairs, and other work that is outside of the warranty. The work may be done at any repair facility. Such work does not need to be performed at a designated station that is determined by the warranty in order for the warranty to remain in force.

i04021417

California Emission Control Warranty Statement

Emissions Warranty

The 1206E-E66TA is a nonroad compression ignition engine.

The California Air Resources Board (CARB) and Perkins Engines Company Limited are pleased to explain the emission control system warranty on your 1206E-E66TA diesel engine.

In California, new motor vehicle engines must be designed, built, and equipped in order to meet the state’s stringent anti-smog standards. Perkins Engines Company Limited must warrant the emission control system on your engine for the duration of time listed below. Provided, there has not been any abuse, neglect, or improper maintenance of your engine or your engine aftertreatment system.

Perkins Engines Company Limited warrants to the initial owner and to the subsequent owner of the 1206E-E66TA diesel engine that such an engine is:

1. Designed, built, and equipped so that the engine conforms, at the time of sale, with all applicable regulations adopted by the California Air Resources Board (CARB).
2. Free from defects in materials and workmanship in specific emission-related parts for the following period:
 - The warranty period is for 3000 hours or for 5 years, whichever occurs first. After the date of delivery to the owner that operates the engine.

If an emission-related part fails during any of the warranty periods, the part will be repaired or replaced. Any such part repaired or replaced under warranty is warranted for the remainder of the warranty period.

During the term of this warranty, Perkins Engines Company Limited will provide through a Perkins distributor or your Perkins dealer or other establishment authorized by Perkins Engines Company Limited, repair or replacement of any warranted part at no charge to the engine owner.

In an emergency, repairs may be performed at any service establishment, or by the owner, using any replacement part. Perkins recommended that emission-related parts be replaced with genuine Perkins Engines Company Limited parts.

Perkins Engines Company Limited will reimburse the owner. This reimbursement will include diagnostic charges for such an emergency repair. These expenses shall not exceed the Perkins Engines Company Limited suggested retail price for all warranted parts replaced, and labor charges based on Perkins Engines Company Limited recommended time allowance for the warranty repair and the geographically appropriate hourly labor rate.

As a condition of reimbursement, replaced parts and receipted invoices must be presented at a place of business of a Perkins distributor or your Perkins dealer or other establishment authorized by Perkins Engines Company Limited.

Warranty Section
California Emission Control Warranty Statement

This warranty covers the following emission-related parts and components:

- Turbocharger System
- Inlet Manifold
- Fuel Injection System
- Crankcase Ventilation System
- Electronic Engine Control System
- Engine Aftertreatment System
- NOx Reduction System
- Aftertreatment Regeneration Device
- Miscellaneous valves, switches, hoses, clamps, connectors, tubing, and sealing devices that are used in the above systems

Limitations and Responsibilities

The warranty is subject to the following conditions:

Perkins Engines Company Limited Responsibilities

During the emission warranty period, if a defect in material or workmanship of an emission-related part or component is found, Perkins Engines Company Limited will provide the following:

- New, Remanufactured or repaired parts and/or components, approved pursuant to (CARB) Regulations, required to correct the defect.
- Reasonable and customary labor, during normal working hours that is required to make the warranty repair. Included will be labor in order to remove an engine and install the engine, if necessary.

Note: Items that are replaced under this warranty become the property of Perkins Engines Company Limited .

Owner Responsibilities

During the emission warranty period, the owner is responsible for the following items:

- The costs in order to investigate complaints which are not caused by a defect in Perkins Engines Company Limited material or Perkins Engines Company Limited workmanship.
- Providing timely notice of a warrantable failure and promptly making the product available for repair

Limitations

Perkins Engines Company Limited is not responsible for resultant damages to an emission-related part or component resulting from the following items:

- Any application or any installation that Perkins Engines Company Limited deems improper.
- Attachments, accessory items, or parts not sold nor approved by Perkins Engines Company Limited
- Improper engine maintenance, repair, or abuse.
- Use of improper fuel, lubricants, or fluids.
- Owners unreasonable delay in making the product available after being notified of a potential product problem.

This warranty is in addition to Perkins Engines Company Limited standard warranty, applicable to the engine product involved.

Remedies under this warranty are limited to the provision of material and services as specified herein. Perkins Engines Company Limited is not responsible for incidental or consequential damages, including but not limited to downtime or loss-of-use of engine.

Reference Information Section

www.perkins.com

NOTICE
Dependant upon engine type and application.

Reference Materials

i04224089

Engine Protection Plans (Extended Service Contract)

Extended Service Contracts-purchased in minutes,
protected for years.

Extended Service Contracts (ESC) protect you from the stress that unexpected repair work brings to your life by covering the cost of getting your engine up and running again. Unlike other extended warranties, Perkins Platinum ESC protects you against all component part failures.

Purchase peace of mind from only £0.03 / \$0.05 / euro 0.04 a day and let an ESC make your dreams a reality.

Why buy an Extended Service Contract?

1. No surprises - total protection from unexpected repair cost (parts, labor, and travel).
2. Enjoy longer lasting product support from Perkins global network.
3. Genuine Perkins parts ensure continued engine performance.
4. Highly trained technicians carry out all repairs.
5. Transferable coverage should you sell your machine.

Flexible coverage provides the right level of protection for your Perkins Engine. Coverage can be extended to 2 years/ 1,000 hours right up to 10 year/ 40,000

You can buy an ESC at any time during standard warranty - even the last day!

Each Perkins Distributor has highly trained and experienced Perkins Product Support Service Technicians. The Support Service are equipped, and available around the clock to get your engine running again with the minimum of downtime. Buying an ESC means that you get all this for free.

To purchase an Extended Service Contract, is quick and simple! Contact your local Perkins Distributor now and the distributor can provide you with a quote in minutes. You can locate your nearest Perkins Distributor by visiting:

Index

A

After Starting Engine	54
After Stopping Engine	57
Aftercooler Core - Clean/Test (Air-To-Air Aftercooler)	82
Aftercooler Core - Inspect	82
Alternator - Inspect	82
Alternator and Fan Belts - Replace	82

B

Battery - Replace	82
Battery Electrolyte Level - Check	83
Battery or Battery Cable - Disconnect	83
Before Starting Engine	17, 51
Belt - Inspect	84
Belt Tensioner - Inspect	84
Burn Prevention	12
Batteries	13
Coolant	13
Induction System	13
Oils	13

C

California Emission Control Warranty Statement	117
Emissions Warranty	117
Cold Weather Operation	59
Hints for Cold-Weather Operation	59
Idling the Engine	60
Recommendations for Coolant Warm Up....	60
Recommendations for the Coolant	60
Viscosity of the Engine Lubrication Oil	60
Cold Weather Starting	52
Configuration Parameters	47
Customer Specified Parameters	48
System Configuration Parameters	47
Cooling System Coolant (Commercial Heavy-Duty) - Change	85
Drain	85
Fill	86
Flush	86
Cooling System Coolant (ELC) - Change	86
Drain	87
Fill	88
Flush	87
Cooling System Coolant Level - Check	88
Engines With a Coolant Recovery Tank	88

Engines Without a Coolant Recovery Tank	89
Cooling System Supplemental Coolant Additive (SCA) - Test/Add	90
Add the SCA, If Necessary	90
Test for SCA Concentration	90
Crushing Prevention and Cutting Prevention..	15

D

Diagnostic Flash Code Retrieval	45
Diagnostic Lamp	45
Driven Equipment - Check	90

E

Electrical System	18
Grounding Practices	19
Emergency Stopping	57
Emissions Certification Film	29
Emissions Warranty Information	116
Maintenance Recommendations	116
Engine - Clean	91
Aftertreatment	91
Engine Air Cleaner Element (Dual Element) - Clean/Replace	91
Cleaning the Primary Air Cleaner Elements	92
Servicing the Air Cleaner Elements	91
Engine Air Cleaner Element (Single Element) - Inspect/Replace	93
Engine Air Cleaner Service Indicator - Inspect	94
Test the Service Indicator	94
Engine Air Precleaner - Check/Clean (If Equipped)	94
Engine Crankcase Breather Element - Replace (Type 1)	95
Bottom Service	96
Check the System	98
Top Service	95
Engine Crankcase Breather Element - Replace (Type 2)	98
Check the System	99
Engine Description	25
Aftermarket Products and Perkins Engines	27
Aftertreatment System	26
Electronic Engine Features	26

Engine Cooling and Lubrication	26	California Proposition 65 Warning	4
Engine Diagnostics	26	Literature Information	4
Engine Service Life	27	Maintenance	4
Engine Specifications	25	Maintenance Intervals	5
Engine Diagnostics	45	Operation	4
Engine Electronics	20	Overhaul	5
Engine Mounts - Inspect	99	Safety	4
Engine Oil and Filter - Change	101	Fuel and the Effect from Cold Weather	61
Drain the Engine Lubricating Oil	101	Fuel Conservation Practices	55
Fill the Oil Pan	102	Fuel Related Components in Cold Weather ...	62
Replace the Oil Filter	101	Fuel Filters	62
Engine Oil Level - Check	100	Fuel Heaters	62
Engine Oil Sample - Obtain	100	Fuel Tanks	62
Obtain the Sample and the Analysis	100	Fuel System - Prime	102
Engine Operation	55	Fuel System Primary Filter (Water	
Reduction of Particulate Emissions	55	Separator) Element - Replace	103
Engine Operation with Active Diagnostic		In-line Strainer	105
Codes	46	Install the Element	105
Engine Operation with Intermittent		Remove the Element	103
Diagnostic Codes	47	Fuel System Primary Filter/Water	
Engine Protection Plans (Extended Service		Separator - Drain	105
Contract)	119	Fuel System Secondary Filter - Replace	106
Engine Shutoffs and Engine Alarms	43	Install the Element	107
Alarms	43	Remove the Element	106
Shutoffs	43	Fuel Tank Water and Sediment - Drain	108
Testing	44	Drain the Water and the Sediment	108
Engine Starting	18, 51	Fuel Storage Tanks	108
Engine Stopping	18, 57	Fuel Tank	108
F		G	
Fault Logging	46	Gauges and Indicators	33
Features and Controls	35	Indicator Lamps	34
Federal Emission Control Warranty	115	Instrument panels and Displays	34
Emissions Warranty	115	General Hazard Information	9
Fire Prevention and Explosion Prevention	13	Containing Fluid Spillage	11
Ether	15	Dispose of Waste Properly	12
Fire Extinguisher	15	Fluid Penetration	10
Lines, Tubes, and Hoses	15	Inhalation	11
Fluid Recommendations	63, 68	Pressurized Air and Water	10
ELC Cooling System Maintenance	66	Static Electricity Hazard when Fueling with	
Engine Oil	68	Ultra-low Sulfur Diesel Fuel	11
General Coolant Information	63	H	
General Lubricant Information	68	High Pressure Fuel Lines	16
Fluid Recommendations (General Fuel		Hoses and Clamps - Inspect/Replace	108
Information)	70	Replace the Hoses and the Clamps	109
Contamination Control Recommendations for		I	
Fuels	78	Important Safety Information	2
Diesel Fuel Characteristics	74		
Diesel Fuel Requirements	71		
General Information	71		
Foreword	4		

L		Reference Information Section	119
Lifting and Storage	30	Reference Materials	119
M		Reference Numbers	28
Maintenance Interval Schedule.....	81	Record for Reference	28
Daily	81	Refill Capacities.....	63
Every 1000 Service Hours.....	81	Cooling System.....	63
Every 12 000 Service Hours or 6 Years.....	81	Lubrication System	63
Every 1500 Service Hours.....	81	S	
Every 2000 Service Hours.....	81	Safety Messages.....	6
Every 3000 Service Hours.....	81	(1) Universal Warning	6
Every 3000 Service Hours or 2 Years	81	(2) Hand (High Pressure)	7
Every 4000 Service Hours.....	81	Ether Warning.....	8
Every 50 Service Hours or Weekly	81	Safety Section	6
Every 500 Service Hours.....	81	Self-Diagnostics	45
Every 500 Service Hours or 1 Year	81	Sensors and Electrical Components.....	37
Every Week	81	Sensors and Electrical Components	
When Required.....	81	(Aftertreatment).....	37
Maintenance Recommendations	79	Severe Service Application - Check.....	110
Maintenance Section.....	63	Environmental Factors.....	110
Model View Illustrations	21	Incorrect Maintenance Procedures	110
Engine Aftertreatment System	25	Incorrect Operating Procedures	110
Engine views.....	21	Starting Motor - Inspect.....	111
Model Views	21	Starting the Engine.....	51
Monitoring System.....	36	Starting the Engine	51
Programmable Options and Systems		Starting with Jump Start Cables (Do Not	
Operation	36	Use This Procedure in Hazardous	
Monitoring System (Table for the Indicator		Locations that have Explosive	
lamps).....	35	Atmospheres).....	53
Mounting and Dismounting	16	Stopping the Engine	57
O		System Pressure Release.....	79
Operation Section.....	30	Coolant System	79
Overspeed.....	44	Engine Oil	79
P		Fuel System.....	79
Plate Locations and Film Locations (Engine		T	
Aftertreatment System)	28	Table of Contents	3
Product Identification Information	28	Turbocharger - Inspect.....	111
Product Information Section.....	21	W	
Product Lifting (Clean Emission Module).....	31	Walk-Around Inspection	112
Product Lifting (Engine).....	30	High Pressure Fuel Lines	113
Product Storage (Engine and		Inspect the Engine for Leaks and for Loose	
Aftertreatment)	31	Connections	112
Condition for Storage.....	31	Inspect the Tube of the Crankcase	
R		Breather	112
Radiator - Clean	109	Warranty Information.....	115
		Warranty Section.....	115
		Water Pump - Inspect.....	113

Welding on Engines with Electronic
Controls 79

Product and Dealer Information

Note: For product identification plate locations, see the section "Product Identification Information" in the Operation and Maintenance Manual.

Delivery Date: _____

Product Information

Model: _____

Product Identification Number: _____

Engine Serial Number: _____

Transmission Serial Number: _____

Generator Serial Number: _____

Attachment Serial Numbers: _____

Attachment Information: _____

Customer Equipment Number: _____

Dealer Equipment Number: _____

Dealer Information

Name: _____ Branch: _____

Address: _____

Dealer Contact

Phone Number

Hours

Sales: _____

Parts: _____

Service: _____

SEBU8603
©2023 Perkins Engines Company Limited
All Rights Reserved