

Operation and Maintenance Manual

1104D-E44T and 1104D-E44TA Industrial Engines

NP (Engine)
NR (Engine)



Important Safety Information

Most accidents that involve product operation, maintenance and repair are caused by failure to observe basic safety rules or precautions. An accident can often be avoided by recognizing potentially hazardous situations before an accident occurs. A person must be alert to potential hazards. This person should also have the necessary training, skills and tools to perform these functions correctly.

Incorrect operation, lubrication, maintenance or repair of this product can be dangerous and could result in injury or death.

Do not operate or perform any lubrication, maintenance or repair on this product, until you have read and understood the operation, lubrication, maintenance and repair information.

Safety precautions and warnings are provided in this manual and on the product. If these hazard warnings are not heeded, bodily injury or death could occur to you or to other persons.

The hazards are identified by the "Safety Alert Symbol" and followed by a "Signal Word" such as "DANGER", "WARNING" or "CAUTION". The Safety Alert "WARNING" label is shown below.



The meaning of this safety alert symbol is as follows:

Attention! Become Alert! Your Safety is Involved.

The message that appears under the warning explains the hazard and can be either written or pictorially presented.

Operations that may cause product damage are identified by "NOTICE" labels on the product and in this publication.

Perkins cannot anticipate every possible circumstance that might involve a potential hazard. The warnings in this publication and on the product are, therefore, not all inclusive. You must not use this product in any manner different from that considered by this manual without first satisfying yourself that you have considered all safety rules and precautions applicable to the operation of the product in the location of use, including site-specific rules and precautions applicable to the worksite. If a tool, procedure, work method or operating technique that is not specifically recommended by Perkins is used, you must satisfy yourself that it is safe for you and for others. You should also ensure that you are authorized to perform this work, and that the product will not be damaged or become unsafe by the operation, lubrication, maintenance or repair procedures that you intend to use.

The information, specifications, and illustrations in this publication are on the basis of information that was available at the time that the publication was written. The specifications, torques, pressures, measurements, adjustments, illustrations, and other items can change at any time. These changes can affect the service that is given to the product. Obtain the complete and most current information before you start any job. Perkins dealers or Perkins distributors have the most current information available.



When replacement parts are required for this product Perkins recommends using Perkins replacement parts.

Failure to heed this warning can lead to premature failures, product damage, personal injury or death.

In the United States, the maintenance, replacement, or repair of the emission control devices and systems may be performed by any repair establishment or individual of the owner's choosing.

Table of Contents

Foreword	4
----------------	---

Safety Section

Safety Messages	6
-----------------------	---

General Hazard Information	8
----------------------------------	---

Burn Prevention	12
-----------------------	----

Fire Prevention and Explosion Prevention	13
--	----

Crushing Prevention and Cutting Prevention ..	14
---	----

Mounting and Dismounting	15
--------------------------------	----

High Pressure Fuel Lines	15
--------------------------------	----

Before Starting Engine	17
------------------------------	----

Engine Starting	17
-----------------------	----

Engine Stopping	18
-----------------------	----

Electrical System	18
-------------------------	----

Engine Electronics	19
--------------------------	----

Product Information Section

General Information	20
---------------------------	----

Product Identification Information	27
--	----

Operation Section

Lifting and Storage	29
---------------------------	----

Features and Controls	31
-----------------------------	----

Engine Diagnostics	42
--------------------------	----

Engine Starting	49
-----------------------	----

Engine Operation	53
------------------------	----

Cold Weather Operation	54
------------------------------	----

Engine Stopping	58
-----------------------	----

Maintenance Section

Refill Capacities	60
-------------------------	----

Maintenance Recommendations	73
-----------------------------------	----

Maintenance Interval Schedule	75
-------------------------------------	----

Warranty Section

Warranty Information	107
----------------------------	-----

Reference Information Section

Reference Materials	108
---------------------------	-----

Index Section

Index	109
-------------	-----

Foreword

California Proposition 65 Warning

Diesel engine exhaust and some of its constituents are known to the State of California to cause cancer, birth defects, and other reproductive harm.



WARNING – This product can expose you to chemicals including ethylene glycol, which is known to the State of California to cause birth defects or other reproductive harm. For more information go to:

www.P65Warnings.ca.gov

Do not ingest this chemical. Wash hands after handling to avoid incidental ingestion.



WARNING – This product can expose you to chemicals including lead and lead compounds, which are known to the State of California to cause cancer, birth defects, or other reproductive harm. For more information go to:

www.P65Warnings.ca.gov

Wash hands after handling components that may contain lead.

Literature Information

This manual contains safety, operation instructions, lubrication, and maintenance information. This manual should be stored in or near the engine area in a literature holder or literature storage area. Read, study, and keep the manual with the literature and engine information.

English is the primary language for all Perkins publications. The English used facilitates translation and consistency.

Some photographs or illustrations in this manual show details or attachments that may be different from your engine. Guards and covers may have been removed for illustrative purposes. Continuing improvement and advancement of product design may have caused changes to your engine which are not included in this manual. Whenever a question arises regarding your engine, or this manual, please consult with your Perkins dealer or your Perkins distributor for the latest available information.

Safety

This safety section lists basic safety precautions. In addition, this section identifies hazardous, warning situations. Read and understand the basic precautions listed in the safety section before operating or performing lubrication, maintenance, and repair on this product.

Operation

Operating techniques outlined in this manual are basic. The operating techniques assist with developing the skills and techniques required to operate the engine more efficiently and economically. Skill and techniques develop as the operator gains knowledge of the engine and the capabilities of the engine.

The operation section is a reference for operators. Photographs and illustrations guide the operator through procedures of inspecting, starting, operating, and stopping the engine. This section also includes a discussion of electronic diagnostic information.

Maintenance

The maintenance section is a guide to engine care. The illustrated, step-by-step instructions are grouped by service hours and/or calendar time maintenance intervals. Items in the maintenance schedule are referenced to detailed instructions that follow.

Recommended service should be performed at the appropriate intervals as indicated in the Maintenance Interval Schedule. The actual operating environment of the engine also governs the Maintenance Interval Schedule. Therefore, under severe, dusty, wet, or freezing cold operating conditions, more frequent lubrication, and maintenance than is specified in the Maintenance Interval Schedule may be necessary.

The maintenance schedule items are organized for a preventive maintenance management program. If the preventive maintenance program is followed, a periodic tune-up is not required. The implementation of a preventive maintenance management program should minimize operating costs through cost avoidances resulting from reductions in unscheduled downtime and failures.

Maintenance Intervals

Perform maintenance on items at multiples of the original requirement. Each level and/or individual items in each level should be shifted ahead or back depending upon your specific maintenance practices, operation, and application. Perkins recommends that the maintenance schedules be reproduced and displayed near the engine as a convenient reminder. Perkins also recommends that a maintenance record be maintained as part of the permanent record of the engine.

Your authorized Perkins dealer or your Perkins distributor can assist you in adjusting your maintenance schedule to meet the needs of your operating environment.

Overhaul

Major engine overhaul details are not covered in the Operation and Maintenance Manual except for the interval and the maintenance items in that interval. Major repairs are best left to trained personnel or an authorized Perkins distributor or dealer. Your Perkins dealer or your Perkins distributor offers various options regarding overhaul programs. If you experience a major engine failure, there are also numerous after failure overhaul options available. Consult with your Perkins dealer or your Perkins distributor for information regarding these options.

Safety Section

i05461290

Safety Messages

There may be several specific warning signs on your engine. The exact location and a description of the warning signs are reviewed in this section. Become familiar with all warning signs.

Ensure that all of the warning signs are legible. Clean the warning signs or replace the warning signs if the words cannot be read or if the illustrations are not visible. Use a cloth, water, and soap to clean the warning signs. Do not use solvents, gasoline, or other harsh chemicals. Solvents, gasoline, or harsh chemicals could loosen the adhesive that secures the warning signs.

Replace any warning sign that is damaged or missing. If a warning sign is attached to a part of the engine that is replaced, install a new warning sign on the replacement part. Your Perkins dealer or your Perkins distributor can provide new warning signs.

(1) Universal Warning

 **WARNING**

Do not operate or work on this equipment unless you have read and understand the instructions and warnings in the Operation and Maintenance Manuals. Failure to follow the instructions or heed the warnings could result in serious injury or death.

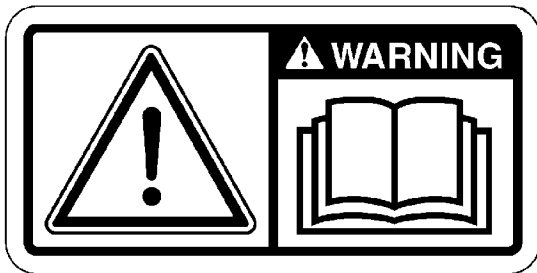

Illustration 1
Typical example

g01154807

The Universal Warning label (1) is located on both sides of the valve mechanism cover base.

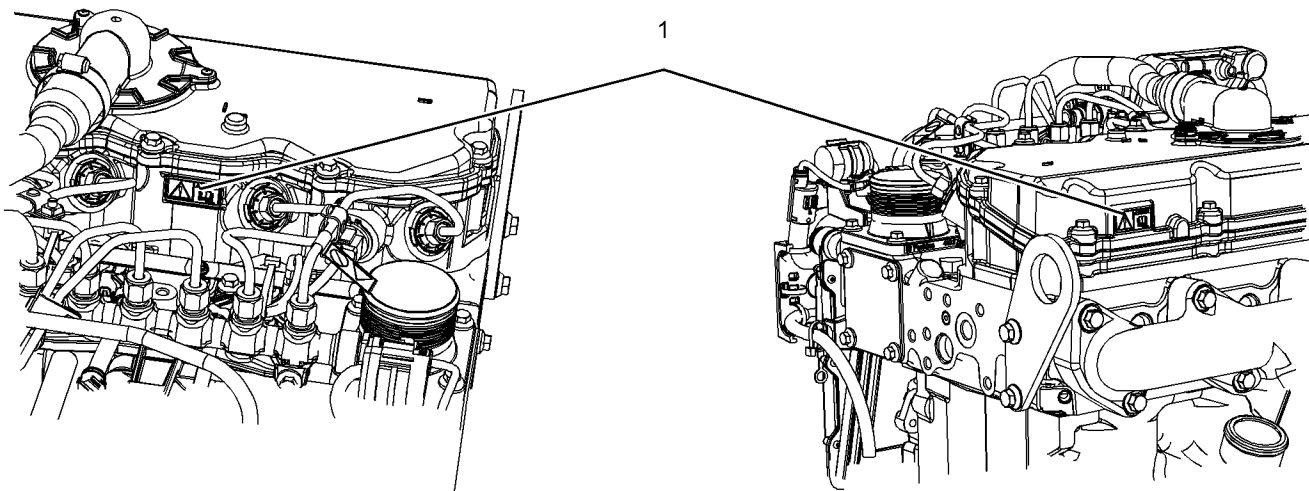

Illustration 2

g03450122

2 Hand (High Pressure)

⚠ WARNING

Contact with high pressure fuel may cause fluid penetration and burn hazards. High pressure fuel spray may cause a fire hazard. Failure to follow these inspection, maintenance and service instructions may cause personal injury or death.

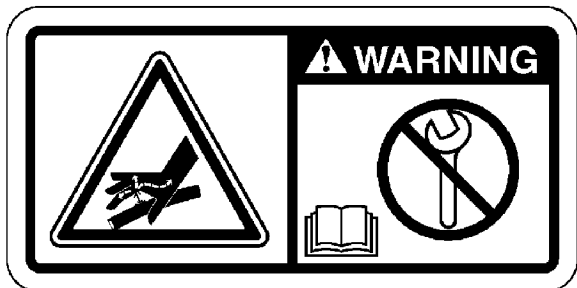

Illustration 3

g01154858

Typical example

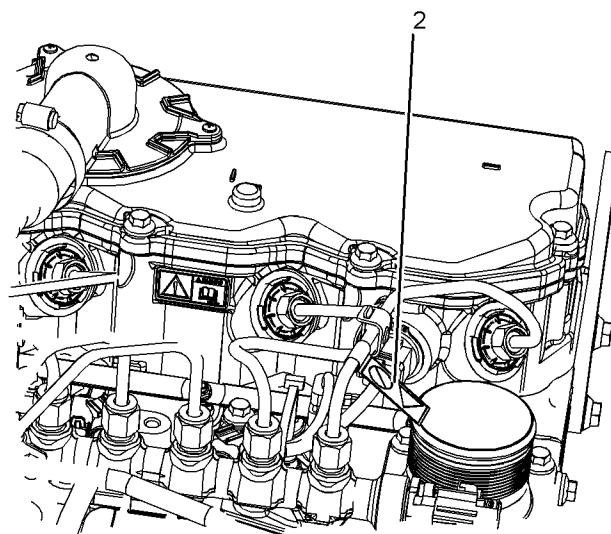

Illustration 4

g03450123

The warning label for the Hand (High Pressure) (2) is a wrap around label that is located on the rear injector line.

Ether

⚠ WARNING

Do not use aerosol types of starting aids such as ether. Such use could result in an explosion and personal injury.



Illustration 5

g01154809

Typical example

The ether warning label is supplied loose for the original equipment manufacture to install the label.

i08315117

General Hazard Information

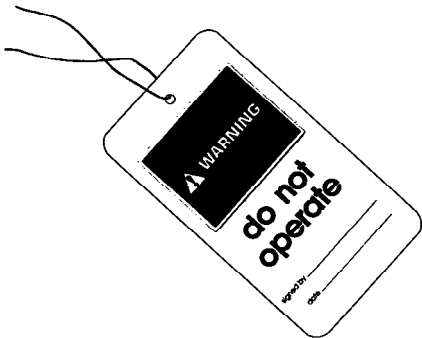

Illustration 6

g00104545

Attach a "Do Not Operate" warning tag or a similar warning tag to the start switch or to the controls before the engine is serviced or before the engine is repaired. Attach the warning tags to the engine and to each operator control station. When appropriate, disconnect the starting controls.

Do not allow unauthorized personnel on the engine, or around the engine when the engine is being serviced.

- Tampering with the engine installation or tampering with the OEM supplied wiring can be dangerous. Personal injury, death and/or engine damage could result.
- Vent the engine exhaust to the outside when the engine is operated in an enclosed area.

- Wear a hard hat, protective glasses, and other protective equipment, as required.
- When working around an engine, the engine must not be in operation. You may only be near a running engine to carry out maintenance procedures that require the engine to be in operation.
- Do not wear loose clothing or jewelry that can snag on controls or on other parts of the engine.
- Ensure that all protective guards and all covers are secured in place on the engine.
- Never put maintenance fluids into glass containers. Glass containers can break.
- Use all cleaning solutions with care.
- Report all necessary repairs.

Unless other instructions are provided, perform the maintenance under the following conditions:

- The engine is stopped. Ensure that the engine cannot be started.
- The protective locks or the controls are in the applied position.
- Disconnect the batteries when maintenance is performed or when the electrical system is serviced. Disconnect the battery ground leads. Tape the leads to help prevent sparks. If equipped, allow the diesel exhaust fluid to be purged before disconnecting the battery.
- If equipped, disconnect the connectors for the unit injectors that are on the valve cover base. This action will help prevent personal injury from the high voltage to the unit injectors. Do not come in contact with the unit injector terminals while the engine is operating.
- Do not attempt any repairs or any adjustments to the engine while the engine is operating.
- Do not attempt any repairs that are not understood. Use the proper tools. Replace any equipment that is damaged or repair the equipment.
- For initial start-up of a new engine or for starting an engine that has been serviced, make provisions to stop the engine if an overspeed occurs. The stopping of the engine may be accomplished by shutting off the fuel supply and/or the air supply to the engine. Ensure that only the fuel supply line is shut off. Ensure that the fuel return line is open.

- Start the engine from the operators station (cab). Never short across the starting motor terminals or the batteries. This action could bypass the engine neutral start system and/or the electrical system could be damaged.

Engine exhaust contains products of combustion which may be harmful to your health. Always start the engine and operate the engine in a well-ventilated area. If the engine is in an enclosed area, vent the engine exhaust to the outside.

Cautiously remove the following parts. To help prevent spraying or splashing of pressurized fluids, hold a rag over the part that is being removed.

- Filler caps
- Grease fittings
- Pressure taps
- Breathers
- Drain plugs

Use caution when cover plates are removed. Gradually loosen, but do not remove the last two bolts or nuts that are at opposite ends of the cover plate or the device. Before removing the last two bolts or nuts, pry the cover loose to relieve any spring pressure or other pressure.

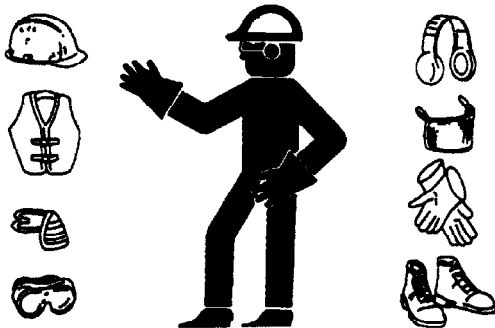

Illustration 7

g00702020

- Wear a hard hat, protective glasses, and other protective equipment, as required.
- Perkins recommend that you do not stand next to an exposed running engine unless it is necessary when carrying out daily checks or maintenance procedures. The appropriate Personal Protective Equipment (PPE) must be worn when standing next to an exposed running engine.
- Do not wear loose clothing or jewelry that can snag on controls or on other parts of the engine.
- Ensure that all protective guards and all covers are secured in place on the engine.

- Never put maintenance fluids into glass containers. Glass containers can break.
- Use all cleaning solutions with care.
- Report all necessary repairs.

Unless other instructions are provided, perform the maintenance under the following conditions:

- The engine is stopped. Ensure that the engine cannot be started.
- Disconnect the batteries when maintenance is performed or when the electrical system is serviced. Disconnect the battery ground leads. Tape the leads to help prevent sparks.
- Do not attempt any repairs that are not understood. Use the proper tools. Replace any equipment that is damaged or repair the equipment.

Pressure Air and Water

Pressurized air and/or water can cause debris and/or hot water to be blown out. This action could result in personal injury.

The direct application of pressurized air or pressurized water to the body could result in personal injury.

When pressurized air and/or water is used for cleaning, wear protective clothing, protective shoes, and eye protection. Eye protection includes goggles or a protective face shield.

The maximum air pressure for cleaning purposes must be below 205 kPa (30 psi). The maximum water pressure for cleaning purposes must be below 275 kPa (40 psi).

Fluid Penetration

Pressure can be trapped in the hydraulic circuit long after the engine has been stopped. The pressure can cause hydraulic fluid or items such as pipe plugs to escape rapidly if the pressure is not relieved correctly.

Do not remove any hydraulic components or parts until pressure has been relieved or personal injury may occur. Do not disassemble any hydraulic components or parts until pressure has been relieved or personal injury may occur. Refer to the OEM information for any procedures that are required to relieve the hydraulic pressure.

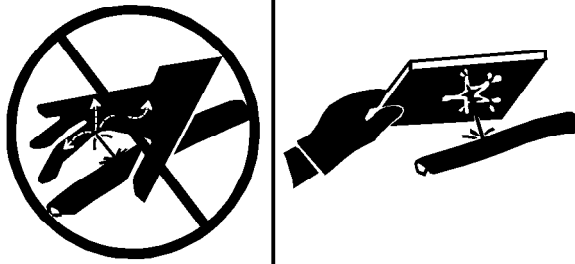

Illustration 8

g00687600

Always use a board or cardboard when you check for a leak. Leaking fluid that is under pressure can penetrate body tissue. Fluid penetration can cause serious injury and possible death. A pin hole leak can cause severe injury. If fluid is injected into your skin, you must get treatment immediately. Seek treatment from a doctor that is familiar with this type of injury.

Containing Fluid Spillage

Care must be taken in order to ensure that fluids are contained during performance of inspection, maintenance, testing, adjusting, and repair of the engine. Make provision to collect the fluid with a suitable container before any compartment is opened or before any component is disassembled.

- Only use the tools that are suitable for collecting fluids and equipment that is suitable for collecting fluids.
- Only use the tools that are suitable for containing fluids and equipment that is suitable for containing fluids.

Obey all local regulations for the disposal of liquids.

Static Electricity Hazard when Fueling with Ultra-low Sulfur Diesel Fuel

The removal of sulfur and other compounds in ultra-low sulfur diesel fuel (ULSD fuel) decreases the conductivity of ULSD and increases the ability of ULSD to store static charge. Refineries may have treated the fuel with a static dissipating additive. Many factors can reduce the effectiveness of the additive over time. Static charges can build up in ULSD fuel while the fuel is flowing through fuel delivery systems. Static electricity discharge when combustible vapors are present could result in a fire or explosion. Ensure that the entire system used to refuel your machine (fuel supply tank, transfer pump, transfer hose, nozzle, and others) is properly grounded and bonded. Consult with your fuel or fuel system supplier to ensure that the delivery system complies with fueling standards for proper grounding and bonding.

WARNING

Avoid static electricity risk when fueling. Ultra-low sulfur diesel fuel (ULSD fuel) poses a greater static ignition hazard than earlier diesel formulations with a higher sulfur contents. Avoid death or serious injury from fire or explosion. Consult with your fuel or fuel system supplier to ensure the delivery system is in compliance with fueling standards for proper grounding and bonding practices.

Inhalation

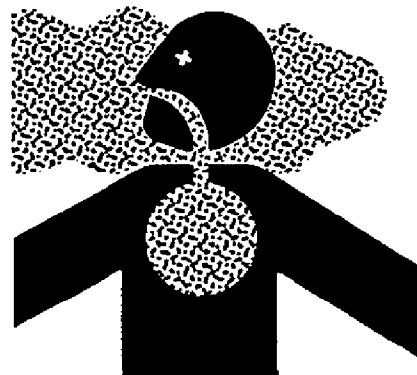

Illustration 9

g00702022

Exhaust

Use caution. Exhaust fumes can be hazardous to health. If you operate the equipment in an enclosed area, adequate ventilation is necessary.

Hexavalent Chromium

Perkins equipment and replacement parts comply with applicable regulations and requirements where originally sold. Perkins recommends the use of only genuine Perkins replacement parts.

Hexavalent chromium has occasionally been detected on exhaust and heat shield systems on Perkins engines. Although laboratory testing is the only accurate way to know if hexavalent chromium is, in fact, present, the presence of a yellow deposit in areas of high heat (for example, exhaust system components or exhaust insulation) may be an indication of the presence of hexavalent chromium.

Use caution if you suspect the presence of hexavalent chromium. Avoid skin contact when handling items that you suspect may contain hexavalent chromium, and avoid inhalation of any dust in the suspect area. Inhalation of, or skin contact with, hexavalent chromium dust may be hazardous to your health.

If such yellow deposits are found on the engine, engine component parts, or associated equipment or packages, Perkins recommends following local health and safety regulations and guidelines, utilizing good hygiene, and adhering to safe work practices when handling the equipment or parts. Perkins also recommends the following:

- Wear appropriate Personal Protective Equipment (PPE)
- Wash your hands and face with soap and water prior to eating, drinking, or smoking, and also during rest room breaks, to prevent ingestion of any yellow powder
- Never use compressed air for cleaning areas suspected of containing hexavalent chromium
- Avoid brushing, grinding, or cutting materials suspected of containing hexavalent chromium
- Obey environmental regulations for the disposal of all materials that may contain or have come into contact with hexavalent chromium
- Stay away from areas that might have hexavalent chromium particles in the air.

Asbestos Information

Perkins equipment and replacement parts that are shipped from Perkins engine company limited are asbestos free. Perkins recommends the use of only genuine Perkins replacement parts. Use the following guidelines when you handle any replacement parts that contain asbestos or when you handle asbestos debris.

Use caution. Avoid inhaling dust that might be generated when you handle components that contain asbestos fibers. Inhaling this dust can be hazardous to your health. The components that may contain asbestos fibers are brake pads, brake bands, lining material, clutch plates, and some gaskets. The asbestos that is used in these components is usually bound in a resin or sealed in some way. Normal handling is not hazardous unless airborne dust that contains asbestos is generated.

If dust that may contain asbestos is present, there are several guidelines that should be followed:

- Never use compressed air for cleaning.
- Avoid brushing materials that contain asbestos.
- Avoid grinding materials that contain asbestos.
- Use a wet method to clean up asbestos materials.
- A vacuum cleaner that is equipped with a high efficiency particulate air filter (HEPA) can also be used.
- Use exhaust ventilation on permanent machining jobs.
- Wear an approved respirator if there is no other way to control the dust.
- Comply with applicable rules and regulations for the work place. In the United States, use Occupational Safety and Health Administration (OSHA) requirements. These OSHA requirements can be found in "29 CFR 1910.1001".
- Obey environmental regulations for the disposal of asbestos.

- Stay away from areas that might have asbestos particles in the air.

Dispose of Waste Properly

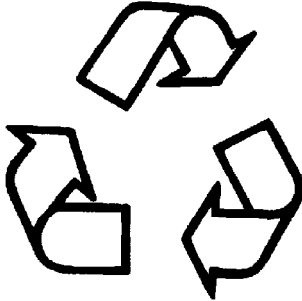

Illustration 10

g00706404

Improperly disposing of waste can threaten the environment. Potentially harmful fluids should be disposed of according to local regulations.

Always use leakproof containers when you drain fluids. Do not pour waste onto the ground, down a drain, or into any source of water.

i05302522

Burn Prevention

Do not touch any part of an operating engine. Allow the engine to cool before any maintenance is performed on the engine.

WARNING

Contact with high pressure fuel may cause fluid penetration and burn hazards. High pressure fuel spray may cause a fire hazard. Failure to follow these inspection, maintenance and service instructions may cause personal injury or death.

NOTICE

The low-pressure fuel system can be pressurized for a time period after the engine has stopped operating. The operating pressure of the low-pressure fuel system can be 500 kPa (73 psi). The secondary fuel filters should be drained before any maintenance of the low-pressure fuel system is carried out.

After the engine has stopped, you must wait for 60 seconds in order to allow the fuel pressure to be purged from the high-pressure fuel lines before any service or repair is performed on the engine fuel lines.

Allow the pressure to be purged in the air system, in the hydraulic system, in the lubrication system, or in the cooling system before any lines, fittings, or related items are disconnected.

Coolant

When the engine is at operating temperature, the engine coolant is hot. The coolant is also under pressure. The radiator and all lines to the heaters or to the engine contain hot coolant.

Any contact with hot coolant or with steam can cause severe burns. Allow cooling system components to cool before the cooling system is drained.

Check that the coolant level after the engine has stopped and the engine has been allowed to cool.

Ensure that the filler cap is cool before removing the filler cap. The filler cap must be cool enough to touch with a bare hand. Remove the filler cap slowly in order to relieve pressure.

Cooling system conditioner contains alkali. Alkali can cause personal injury. Do not allow alkali to contact the skin, the eyes, or the mouth.

Oils

Hot oil and hot lubricating components can cause personal injury. Do not allow hot oil to contact the skin. Also, do not allow hot components to contact the skin.

Batteries

Electrolyte is an acid. Electrolyte can cause personal injury. Do not allow electrolyte to contact the skin or the eyes. Always wear protective glasses for servicing batteries. Wash hands after touching the batteries and connectors. Use of gloves is recommended.

i04823662

Fire Prevention and Explosion Prevention



Illustration 11

g00704000

All fuels, most lubricants, and some coolant mixtures are flammable.

Flammable fluids that are leaking or spilled onto hot surfaces or onto electrical components can cause a fire. Fire may cause personal injury and property damage.

After the emergency stop button is operated, ensure that you allow 15 minutes, before the engine covers are removed.

Determine whether the engine will be operated in an environment that allows combustible gases to be drawn into the air inlet system. These gases could cause the engine to overspeed. Personal injury, property damage, or engine damage could result.

If the application involves the presence of combustible gases, consult your Perkins dealer and/or your Perkins distributor for additional information about suitable protection devices.

Remove all flammable combustible materials or conductive materials such as fuel, oil, and debris from the engine. Do not allow any flammable combustible materials or conductive materials to accumulate on the engine.

Store fuels and lubricants in correctly marked containers away from unauthorized persons. Store oily rags and any flammable materials in protective containers. Do not smoke in areas that are used for storing flammable materials.

Do not expose the engine to any flame.

Exhaust shields (if equipped) protect hot exhaust components from oil or fuel spray in a line, a tube, or a seal failure. Exhaust shields must be installed correctly.

Do not weld on lines or tanks that contain flammable fluids. Do not flame cut lines or tanks that contain flammable fluid. Clean any such lines or tanks thoroughly with a nonflammable solvent prior to welding or flame cutting.

Wiring must be kept in good condition. Ensure that all electrical wires are correctly routed and securely attached. Check all electrical wires daily. Repair any wires that are loose or frayed before you operate the engine. Clean all electrical connections and tighten all electrical connections.

Eliminate all wiring that is unattached or unnecessary. Do not use any wires or cables that are smaller than the recommended gauge. Do not bypass any fuses and/or circuit breakers.

Arcing or sparking could cause a fire. Secure connections, recommended wiring, and correctly maintained battery cables will help to prevent arcing or sparking.

WARNING

Contact with high pressure fuel may cause fluid penetration and burn hazards. High pressure fuel spray may cause a fire hazard. Failure to follow these inspection, maintenance and service instructions may cause personal injury or death.

After the engine has stopped, wait for 60 seconds in order to allow the fuel pressure to be purged from the high-pressure fuel lines before any service or repair is performed on the engine fuel lines.

Ensure that the engine is stopped. Inspect all lines and hoses for wear or for deterioration. Properly route all hoses. The lines and hoses must have adequate support and secure clamps.

Safety Section
Crushing Prevention and Cutting Prevention

Properly install oil filters and fuel filters. The filter housings must be tightened to the correct torque. Refer to the Disassembly and Assembly manual for more information.



Illustration 12

g00704059

Use caution when you are refueling an engine. Do not smoke while you are refueling an engine. Do not refuel an engine near open flames or sparks. Always stop the engine before refueling.

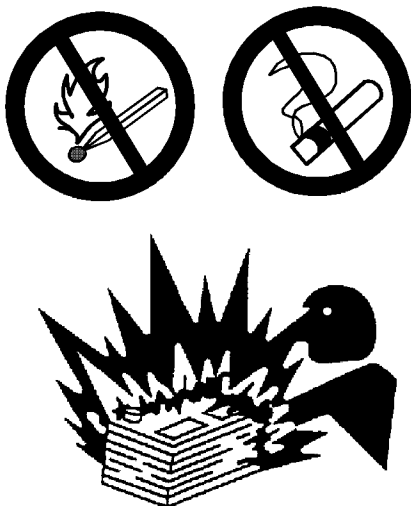

Illustration 13

g02298225

Gases from a battery can explode. Keep any open flames or sparks away from the top of a battery. Do not smoke in battery charging areas.

Never check the battery charge by placing a metal object across the terminal posts. Use a voltmeter or a hydrometer.

Incorrect jumper cable connections can cause an explosion that can result in injury. Refer to the Operation Section of this manual for specific instructions.

Do not charge a frozen battery. Charging a frozen battery may cause an explosion.

The batteries must be kept clean. The covers (if equipped) must be kept on the cells. Use the recommended cables, connections, and battery box covers when the engine is operated.

Fire Extinguisher

Make sure that a fire extinguisher is available. Be familiar with the operation of the fire extinguisher. Inspect the fire extinguisher and service the fire extinguisher regularly. Obey the recommendations on the instruction plate.

Lines, Tubes, and Hoses

Do not bend high-pressure lines. Do not strike high-pressure lines. Do not install any lines that are damaged.

Leaks can cause fires. Consult your Perkins dealer or your Perkins distributor for replacement parts.

Replace the parts if any of the following conditions are present:

- High-pressure fuel line or lines are removed.
- End fittings are damaged or leaking.
- Outer coverings are chafed or cut.
- Wires are exposed.
- Outer coverings are ballooning.
- Flexible parts of the hoses are kinked.
- Outer covers have embedded armoring.
- End fittings are displaced.

Make sure that all clamps, guards, and heat shields are installed correctly in order to prevent vibration, rubbing against other parts, and excessive heat.

i02143194

Crushing Prevention and Cutting Prevention

Support the component correctly when work beneath the component is performed.

Unless other maintenance instructions are provided, never attempt adjustments while the engine is running.

Stay clear of all rotating parts and of all moving parts. Leave the guards in place until maintenance is performed. After the maintenance is performed, reinstall the guards.

Keep objects away from moving fan blades. The fan blades will throw objects or cut objects.

When objects are struck, wear protective glasses in order to avoid injury to the eyes.

Chips or other debris may fly off objects when objects are struck. Before objects are struck, ensure that no one will be injured by flying debris.

i05463929

Mounting and Dismounting

Do not climb on the engine. The engine has not been designed with mounting or dismounting locations.

Refer to the Original Equipment Manufacture (OEM) for the location of foot and hand holds for your specific application.

i05463931

High Pressure Fuel Lines

 **WARNING**

Contact with high pressure fuel may cause fluid penetration and burn hazards. High pressure fuel spray may cause a fire hazard. Failure to follow these inspection, maintenance and service instructions may cause personal injury or death.

Safety Section
High Pressure Fuel Lines

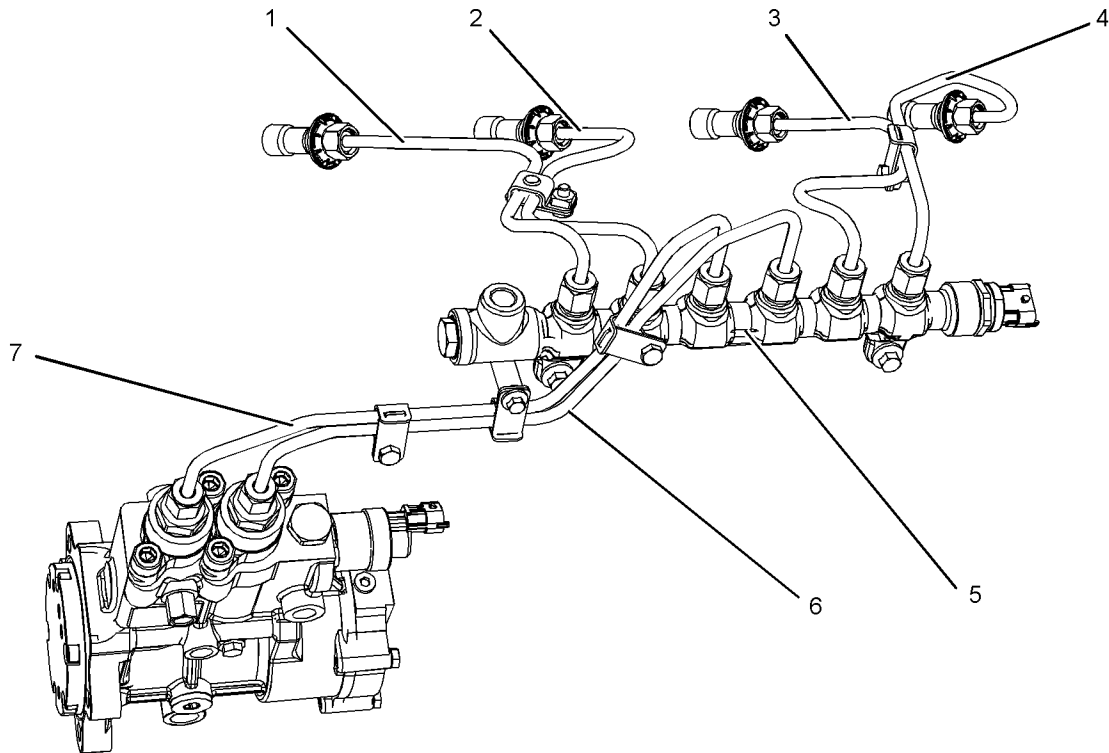

Illustration 14

g03452057

(1) High-pressure line
(2) High-pressure line
(3) High-pressure line

(4) High-pressure line
(5) High-pressure fuel manifold (rail)
(6) High-pressure supply line

(7) High-pressure supply line

The high-pressure fuel lines are the fuel lines that are between the high-pressure fuel pump and the high-pressure fuel manifold and the fuel lines that are between the fuel manifold and cylinder head. These fuel lines are different from fuel lines on other fuel systems.

This difference is because of the following items:

- The high-pressure fuel lines are constantly charged with high pressure.
- The internal pressures of the high-pressure fuel lines are higher than other types of fuel system.
- The high-pressure fuel lines are formed to shape and then strengthened by a special process.

Do not step on the high-pressure fuel lines. Do not deflect the high-pressure fuel lines. Do not bend or strike the high-pressure fuel lines. Deformation or damage of the high-pressure fuel lines may cause a point of weakness and potential failure.

Do not check the high-pressure fuel lines with the engine or the starting motor in operation. After the engine has stopped, allow 90 seconds to pass in order to allow the pressure to be purged before any service or repair is performed on the engine fuel lines.

Do not loosen the high-pressure fuel lines in order to remove air from the fuel system. This procedure is not required.

Visually inspect the high-pressure fuel lines before the engine is started. This inspection should be each day.

If you inspect the engine in operation, always use the proper inspection procedure in order to avoid a fluid penetration hazard. Refer to Operation and Maintenance Manual, "General hazard Information".

- Inspect the high-pressure fuel lines for damage, deformation, a nick, a cut, a crease, or a dent.
- Do not operate the engine with a fuel leak. If there is a leak, do not tighten the connection in order to stop the leak. The connection must only be tightened to the recommended torque. Refer to Disassembly and Assembly, "Fuel injection lines - Remove and Fuel injection lines - Install".
- If the high-pressure fuel lines are torqued correctly and the high-pressure fuel lines are leaking, the high-pressure fuel lines must be replaced.

- Ensure that all clips on the high-pressure fuel lines are in place. Do not operate the engine with clips that are damaged, missing, or loose.
- Do not attach any other item to the high-pressure fuel lines.
- Loosened high-pressure fuel lines must be replaced. Also removed high-pressure fuel lines must be replaced. Refer to Disassembly and assembly manual, “Fuel Injection Lines - Install”.

NOTICE

The low-pressure fuel system can be pressurized for a time period after the engine has stopped operating. The operating pressure of the low-pressure fuel system can be 500 kPa (73 psi). The secondary fuel filters should be drained before any maintenance of the low-pressure fuel system is carried out.

i05874054

Before Starting Engine**NOTICE**

For initial start-up of a new or rebuilt engine, and for start-up of an engine that has been serviced, make provision to shut the engine off should an overspeed occur. This may be accomplished by shutting off the air and/or fuel supply to the engine.

WARNING

Engine exhaust contains products of combustion which may be harmful to your health. Always start and operate the engine in a well ventilated area and, if in an enclosed area, vent the exhaust to the outside.

Inspect the engine for potential hazards.

Do not start the engine or move any of the controls if there is a “DO NOT OPERATE” warning tag or similar warning tag attached to the start switch or to the controls.

Before starting the engine, ensure that no one is on, underneath, or close to the engine. Ensure that the area is free of personnel.

If equipped, ensure that the lighting system for the engine is suitable for the conditions. Ensure that all lights work properly, if equipped.

All protective guards and all protective covers must be installed if the engine must be started in order to perform service procedures. To help prevent an accident that is caused by parts in rotation, work around the parts carefully.

Do not bypass the automatic shutoff circuits. Do not disable the automatic shutoff circuits. The circuits are provided in order to help prevent personal injury. The circuits are also provided in order to help prevent engine damage.

See the Service Manual for repairs and for adjustments.

i02251260

Engine Starting**WARNING**

Do not use aerosol types of starting aids such as ether. Such use could result in an explosion and personal injury.

If a warning tag is attached to the engine start switch or to the controls DO NOT start the engine or move the controls. Consult with the person that attached the warning tag before the engine is started.

All protective guards and all protective covers must be installed if the engine must be started in order to perform service procedures. To help prevent an accident that is caused by parts in rotation, work around the parts carefully.

Start the engine from the operator's compartment or from the engine start switch.

Always start the engine according to the procedure that is described in the Operation and Maintenance Manual, “Engine Starting” topic in the Operation Section. Knowing the correct procedure will help to prevent major damage to the engine components. Knowing the procedure will also help to prevent personal injury.

To ensure that the jacket water heater (if equipped) and/or the lube oil heater (if equipped) is working correctly, check the water temperature gauge and/or the oil temperature gauge during the heater operation.

Engine exhaust contains products of combustion which can be harmful to your health. Always start the engine and operate the engine in a well ventilated area. If the engine is started in an enclosed area, vent the engine exhaust to the outside.

Note: The engine is equipped with a device for cold starting. If the engine will be operated in very cold conditions, then an extra cold starting aid may be required. Normally, the engine will be equipped with the correct type of starting aid for your region of operation.

These engines are equipped with a glow plug starting aid in each individual cylinder that heats the intake air in order to improve starting.

i02234873

Engine Stopping

Stop the engine according to the procedure in the Operation and Maintenance Manual, "Engine Stopping (Operation Section)" in order to avoid overheating of the engine and accelerated wear of the engine components.

Use the Emergency Stop Button (if equipped) **ONLY** in an emergency situation. Do not use the Emergency Stop Button for normal engine stopping. After an emergency stop, **DO NOT** start the engine until the problem that caused the emergency stop has been corrected.

Stop the engine if an overspeed condition occurs during the initial start-up of a new engine or an engine that has been overhauled.

To stop an electronically controlled engine, cut the power to the engine and/or shutting off the air supply to the engine.

i05464430

Electrical System

Never disconnect any charging unit circuit or battery circuit cable from the battery when the charging unit is operating. A spark can cause the combustible gases that are produced by some batteries to ignite.

To help prevent sparks from igniting combustible gases that are produced by some batteries, the negative "-" cable should be connected last from the external power source to the primary position for grounding.

Check the electrical wires daily for wires that are loose or frayed. Tighten all loose electrical connections before the engine is started. Repair all frayed electrical wires before the engine is started. See the Operation and Maintenance Manual for specific starting instructions.

Grounding Practices

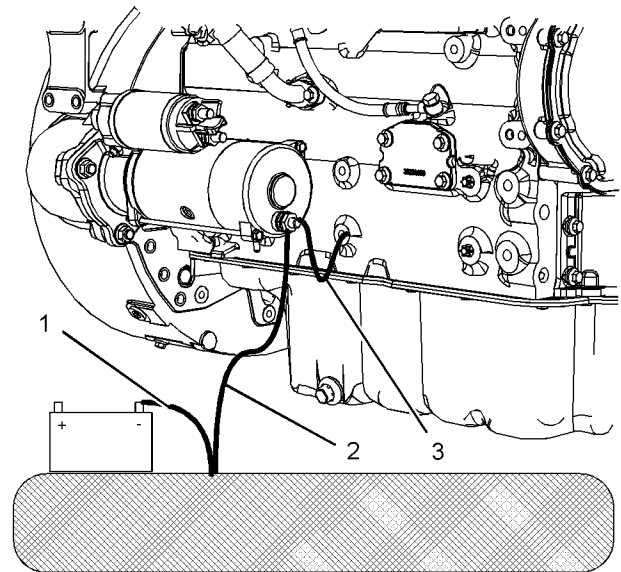

Illustration 15

g03452577

- (1) Ground to battery
- (2) Ground to starting motor
- (3) Starting motor to engine block

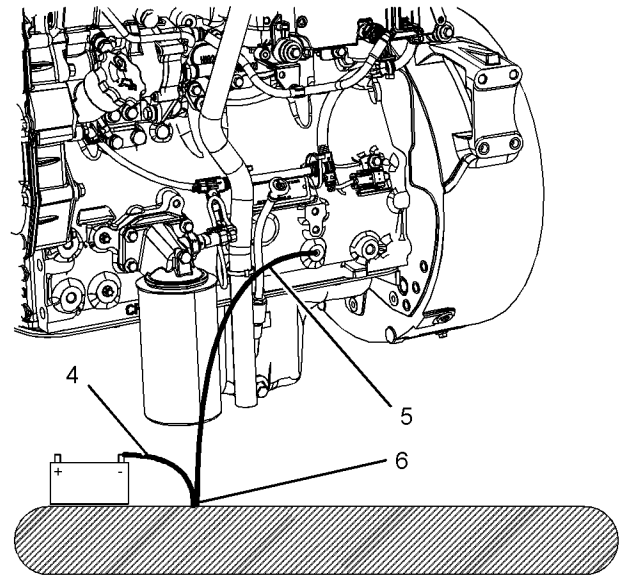

Illustration 16

g03452579

- (4) Battery to ground
- (5) Ground to engine block
- (6) Primary position for grounding

Correct grounding for the engine electrical system is necessary for optimum engine performance and reliability. Incorrect grounding will result in uncontrolled electrical circuit paths and in unreliable electrical circuit paths.

Uncontrolled electrical circuit paths can result in damage to the crankshaft bearing journal surfaces and to aluminum components.

Engines that are installed without engine-to-frame ground straps can be damaged by electrical discharge.

To ensure that the engine and the engine electrical systems function correctly, an engine-to-frame ground strap with a direct path to the battery must be used. This path may be provided by way of a direct engine ground to the frame.

The connections for the grounds should be tight and free of corrosion. The engine alternator must be grounded to the negative “-” battery terminal. The wire used must be adequate to handle the full charging current of the alternator.

The power supply connections and the ground connections for the engine electronics should always be from the isolator to the battery.

i05272352

Engine Electronics

WARNING

Tampering with the electronic system installation or the OEM wiring installation can be dangerous and could result in personal injury or death and/or engine damage.

WARNING

Electrical Shock Hazard. The electronic unit injectors use DC voltage. The ECM sends this voltage to the electronic unit injectors. Do not come in contact with the harness connector for the electronic unit injectors while the engine is operating. Failure to follow this instruction could result in personal injury or death.

This engine has a comprehensive, programmable Engine Monitoring System. The Electronic Control Module (ECM) monitors the engine operating conditions. If any of the engine parameters extend outside an allowable range, the ECM will initiate an immediate action.

The following actions are available for engine monitoring control:

- Warning
- Derate
- Shutdown

The following monitored engine operating conditions have the ability to limit engine speed and/or the engine power:

- Engine Coolant Temperature
- Engine Oil Pressure
- Engine Speed
- Intake Manifold Air Temperature
- Intake Manifold Air pressure

The Engine Monitoring package can vary for different engine models and different engine applications. However, the monitoring system and the engine monitoring control will be similar for all engines.

Note: Many of the engine control systems and display modules that are available for Perkins Engines will work in unison with the Engine Monitoring System. Together, the two controls will provide the engine monitoring function for the specific engine application. Refer to the Troubleshooting for more information on the Engine Monitoring System.

Product Information Section

General Information

i05536748

Model View Illustrations

The following model views show typical features of the engine. Due to individual applications, your engine may appear different from the illustrations.

Turbocharged Aftercooled Engine

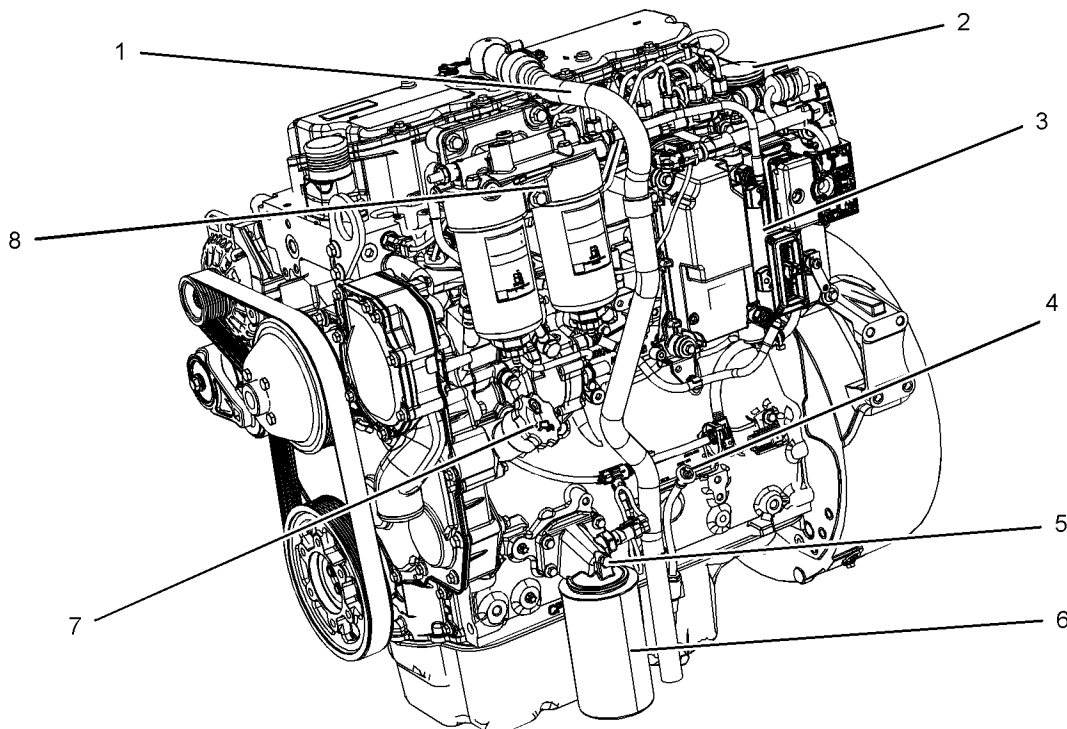

Illustration 17

g03453518

Typical example

- (1) Open Breather System
- (2) Air Intake
- (3) Electronic Control Module

- (4) Oil Level Gauge (Dipstick)
- (5) Location for Oil Sample Valve
- (6) Oil Filter

- (7) Oil Filler
- (8) Secondary Fuel Filters

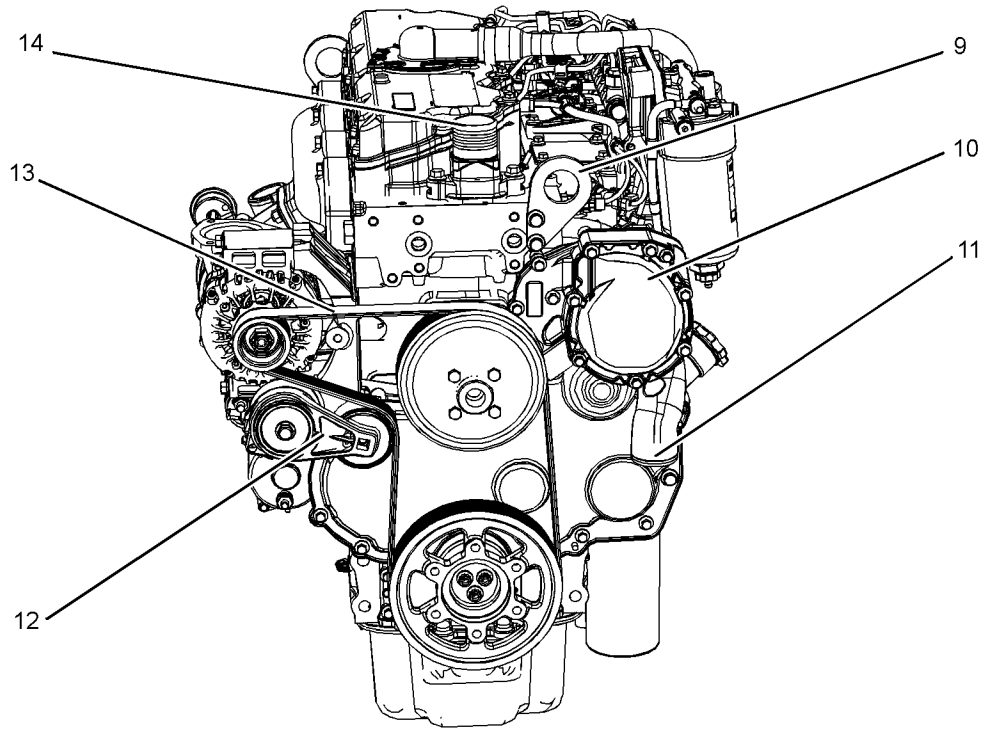

Illustration 18

g03453526

Typical example

(9) Front Lifting Eye
(10) Water Pump

(11) Coolant Intake
(12) Tensioner

(13) Belt
(14) Coolant Outlet

Product Information Section
Model View Illustrations

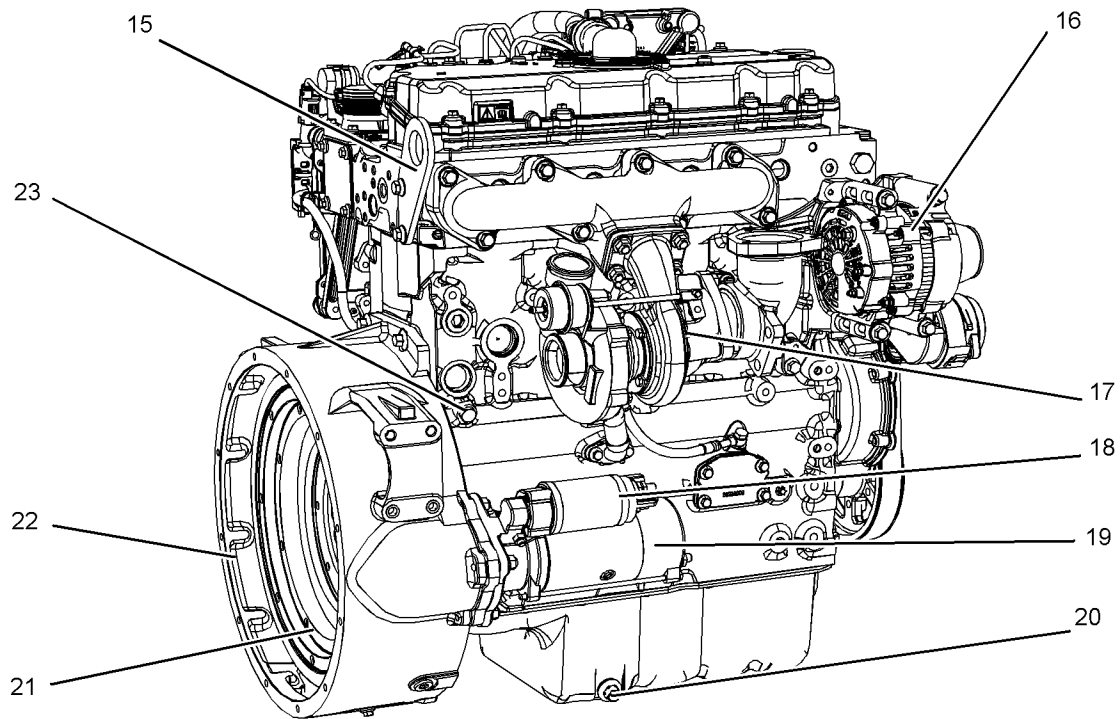

Illustration 19

g03453529

Typical example

(15) Rear Lifting Eye
(16) Alternator
(17) Turbocharger

(18) Starter Solenoid
(19) Starting Motor
(20) Oil Drain Plug

(21) Flywheel
(22) Flywheel Housing
(23) Coolant Drain Plug

Turbocharge Engine View

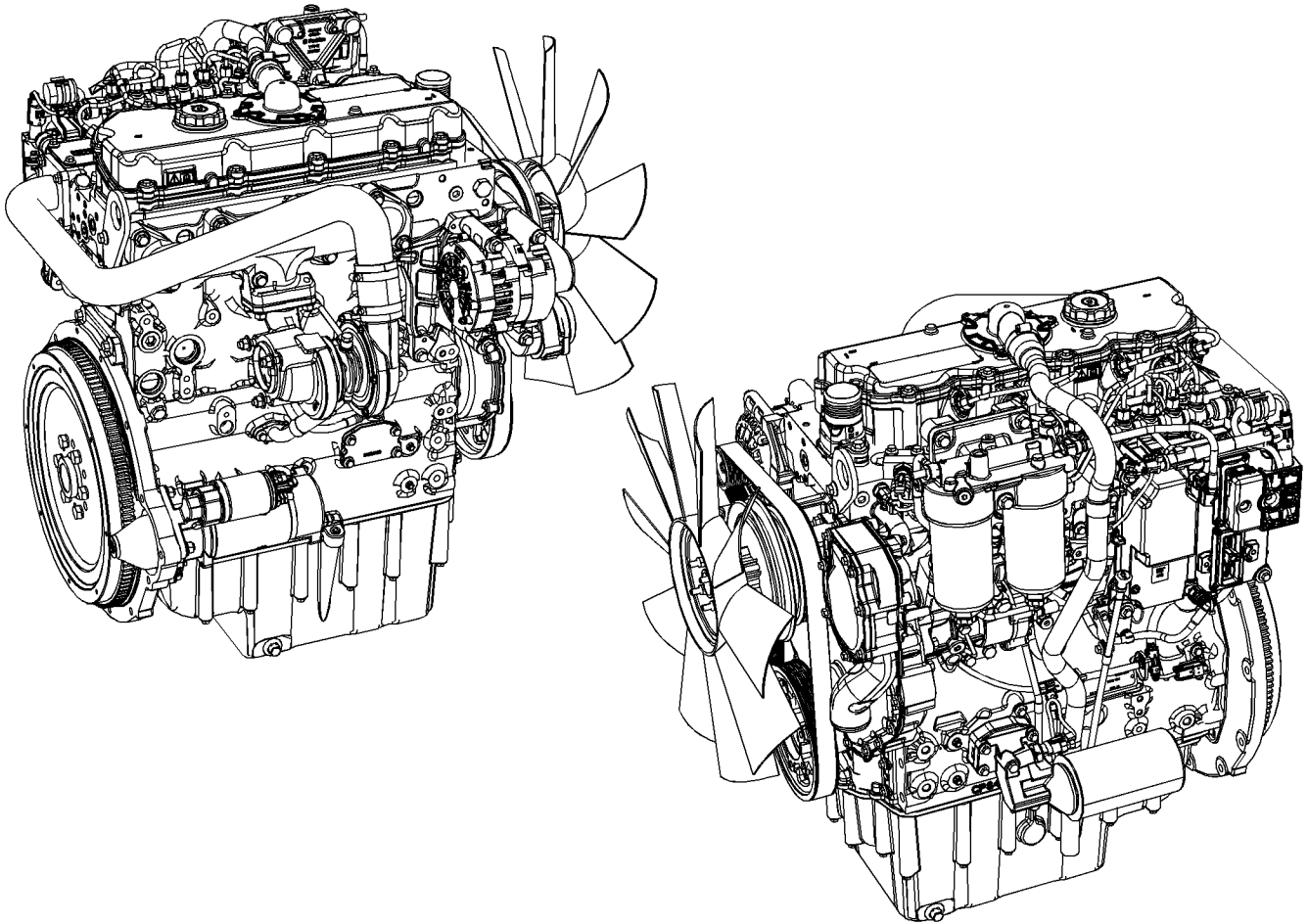

Illustration 20
Typical example

g03506649

Off Engine Parts and Options

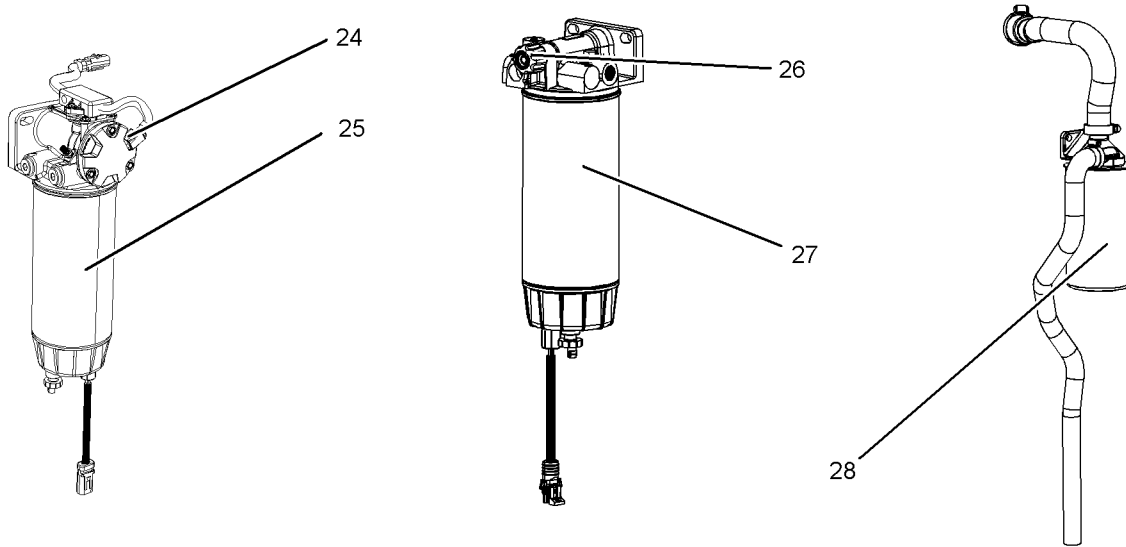

Illustration 21

g03467856

Typical examples

(24) Electric Priming Pump
(25) Primary Fuel Filter

(26) Mechanical Priming Pump
(27) Primary Fuel Filter

(28) Spin on Crankcase Breather

Note: Item (28) is part of the filtered breather system.

i05536753

Product Description

There are two different variants of this Perkins engine. Engines with prefix NR are turbocharged aftercooled engines 1104D-E44TA. Engines with prefix NP are turbocharged engines 1104D-E44T.

Engine Specifications

Note: The front end of the engine is opposite the flywheel end of the engine. The left and the right sides of the engine are determined from the flywheel end. The number 1 cylinder is the front cylinder.

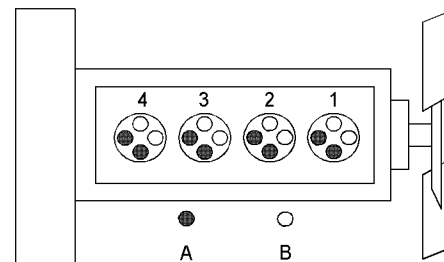

Illustration 22

g01187485

Cylinder and valve location

(A) Exhaust valves
(B) Inlet valves

Table 1

Engine Specifications	
Operating Range (rpm)	900 to 2800 ⁽¹⁾
Number of Cylinders	4 In-Line
Bore	105 mm (4.13 inch)
Stroke	127 mm (5 inch)
Aspiration	Turbocharged or Turbocharged Aftercooled
Compression Ratio	16.2:1
Displacement	4.4 L (268.5 cubic inch)
Firing Order	1-3-4-2
Rotation (flywheel end)	Counterclockwise
Number of valves for each cylinder	4
Valve Lash Setting (Inlet)	0.35 mm (0.013 inch)
Valve Lash Setting (Exhaust)	0.35 mm (0.013 inch)

⁽¹⁾ The operating rpm is dependent on the engine rating, the application, and the configuration of the throttle.

Electronic Engine Features

The engine operating conditions are monitored. The Electronic Control Module (ECM) controls the response of the engine to these conditions and to the demands of the operator. These conditions and operator demands determine the precise control of fuel injection by the ECM. The electronic engine control system provides the following features:

- Engine monitoring
- Engine speed governing
- Control of the injection pressure
- Cold start strategy
- Automatic air/fuel ratio control
- Torque rise shaping
- Injection timing control
- System diagnostics

For more information on electronic engine features, refer to the Operation and Maintenance Manual, “Features and Controls” topic (Operation Section).

Engine Diagnostics

The engine has built-in diagnostics in order to ensure that the engine systems are functioning correctly. The operator will be alerted to the condition by a “Stop or Warning” lamp. Under certain conditions, the engine power and the engine speed may be limited. The electronic service tool may be used to display the diagnostic codes.

There are two types of diagnostic codes: active and logged.

Most of the diagnostic codes are logged and stored in the ECM. For additional information, refer to the Operation and Maintenance Manual, “Engine Diagnostics” topic (Operation Section).

The ECM provides an electronic governor that controls the injector output in order to maintain the desired engine rpm.

For more information refer to Troubleshooting manual.

Engine Cooling and Lubrication

The cooling system consists of the following components:

- Gear-driven centrifugal water pump
- Water temperature regulator which regulates the engine coolant temperature
- Gear-driven rotor type oil pump
- Oil cooler

The engine lubricating oil is supplied by a rotor type oil pump. The engine lubricating oil is cooled and the engine lubricating oil is filtered. The bypass valve can provide unrestricted flow of lubrication oil to the engine if the oil filter element should become plugged.

Engine efficiency, efficiency of emission controls, and engine performance depend on adherence to proper operation and maintenance recommendations. Engine performance and efficiency also depend on the use of recommended fuels, lubrication oils, and coolants. Refer to this Operation and Maintenance Manual, "Maintenance Interval Schedule" for more information on maintenance items.

Option Section

There are two different types of fuel priming pump available, hand primer or an electrically operated primer. There are two different types of crankcase breather, open breather or filtered open breather.

Product Identification Information

i05536932

Plate Locations and Film Locations

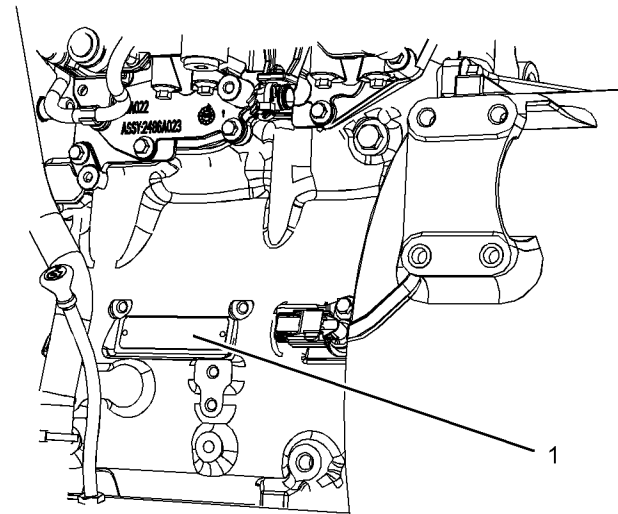
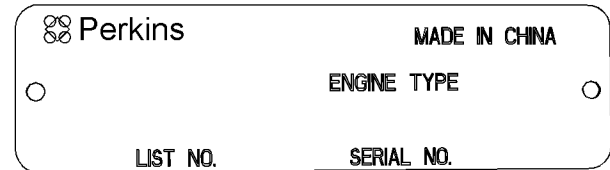

Illustration 23

g03453612

Perkins engines are identified by an engine serial number.

An example of an engine number is N-
*****R000001X.

***** _____ The list number for the engine

N- _____ Type of engine

R _____ Built-in China

000001 _____ Engine Serial Number

X _____ Year of Manufacture

Perkins dealers or Perkins distributors need all of these numbers in order to determine the components that were included with the engine. This information permits accurate identification of replacement part numbers.

Serial Number Plate (1)

The engine serial number plate is located on the left side of the cylinder block to the rear of the front engine mounting.

Emissions Certification Film

Illustration 24

g02433756

Typical example

i05536952

EMISSION CONTROL INFORMATION		 Perkins Engines Co Ltd	Engine Type:												
ENGINE FAMILY:	MODEL YEAR:	LIST NUMBER:	<table border="1" style="width: 100%; border-collapse: collapse;"> <tr> <td style="text-align: center;">Factory set</td> <td style="text-align: center;">Reset if Applicable</td> </tr> <tr> <td style="text-align: center;"><input type="checkbox"/></td> <td style="text-align: center;">kw <input type="checkbox"/></td> </tr> <tr> <td style="text-align: center;"><input type="checkbox"/></td> <td style="text-align: center;">kw <input type="checkbox"/></td> </tr> <tr> <td style="text-align: center;"><input type="checkbox"/></td> <td style="text-align: center;">kw <input type="checkbox"/></td> </tr> <tr> <td style="text-align: center;"><input type="checkbox"/></td> <td style="text-align: center;">kw <input type="checkbox"/></td> </tr> <tr> <td style="text-align: center;"><input type="checkbox"/></td> <td style="text-align: center;">kw <input type="checkbox"/></td> </tr> </table>	Factory set	Reset if Applicable	<input type="checkbox"/>	kw <input type="checkbox"/>	<input type="checkbox"/>	kw <input type="checkbox"/>	<input type="checkbox"/>	kw <input type="checkbox"/>	<input type="checkbox"/>	kw <input type="checkbox"/>	<input type="checkbox"/>	kw <input type="checkbox"/>
Factory set	Reset if Applicable														
<input type="checkbox"/>	kw <input type="checkbox"/>														
<input type="checkbox"/>	kw <input type="checkbox"/>														
<input type="checkbox"/>	kw <input type="checkbox"/>														
<input type="checkbox"/>	kw <input type="checkbox"/>														
<input type="checkbox"/>	kw <input type="checkbox"/>														
DISPLACEMENT:	SERIAL NUMBER:														
INFORMATION APPLICABLE TO USA ONLY			Use Service tool to verify current engine settings												
THIS ENGINE IS SOLELY FOR EXPORT AND IS THEREFORE EXEMPT UNDER 40 CFR 1068 230 FROM EMISSION STANDARDS AND RELATED REQUIREMENTS															
POSITION:															

Illustration 25
Typical example

g03506769

i05465764

Reference Information

Information for the following items may be needed to order parts. Locate the information for your engine. Record the information in the appropriate space. Make a copy of this list for a record. Keep the information for future reference.

Record for Reference

- Engine Model _____
- Engine Serial number _____
- Engine Low Idle rpm _____
- Engine Full Load rpm _____
- Primary Fuel Filter _____
- Secondary Fuel Filter Element _____
- Lubrication Oil Filter _____
- Total Lubrication System Capacity _____
- Total Cooling System Capacity _____
- Air Cleaner Element _____
- Drive Belt _____
- (If equipped) Filtered Breather _____

Operation Section

Lifting and Storage

i04151489

i07451407

Product Lifting

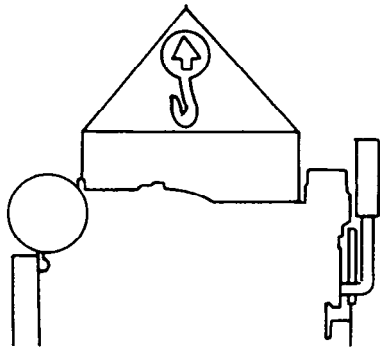

Illustration 26

g00103219

NOTICE

Always inspect lifting eyebolts and all other lifting equipment for damage before performing any lifting. Never bend the eyebolts and the brackets. Never perform product lifting if components are damaged. Only load the eyebolts and the brackets under tension. Remember that the capacity of an eyebolt is less as the angle between the supporting members and the object becomes less than 90 degrees.

When it is necessary to remove a component at an angle, only use a link bracket that is properly rated for the weight.

Use a hoist to remove heavy components. Use an adjustable lifting beam to lift the engine. All supporting members (chains and cables) should be parallel to each other. The chains and cables should be perpendicular to the top of the object that is being lifted.

Some removals require lifting the fixtures to obtain proper balance and safety.

To remove the engine **ONLY**, use the lifting eyes that are on the engine.

Lifting eyes are designed and installed for specific engine arrangements. Alterations to the lifting eyes and/or the engine make the lifting eyes and the lifting fixtures obsolete. If alterations are made, ensure that proper lifting devices are provided. Consult your Perkins dealer for information regarding fixtures for proper engine lifting.

Product Storage

Perkins are not responsible for damage which may occur when an engine is in storage after a period in service.

Your Perkins dealer or your Perkins distributor can assist in preparing the engine for extended storage periods.

Condition for Storage

The engine must be stored in a water proof building. The building must be kept at a constant temperature. Engines that are filled with Perkins ELC will have coolant protection to an ambient temperature of -36°C (-32.8°F). The engine must not be subjected to extreme variations in temperature and humidity.

Storage Period

An engine can be stored for up to 6 months provided all the recommendation are adhered to.

Storage Procedure

Keep a record of the procedure that has been completed on the engine.

Note: Do not store an engine that has biodiesel in the fuel system.

1. Ensure that the engine is clean and dry.
 - a. If the engine has been operated using biodiesel, the system must be drained and new filters installed. The fuel tank will require flushing.
 - b. Fill the fuel system with an acceptable fuel. For more information on acceptable fuels refer to this Operation and Maintenance Manual, "Fluid recommendations". Operate the engine for 15 minutes in order to remove all biodiesel from the system.
2. Drain any water from the primary filter water separator. Ensure that the fuel tank is full.
3. The engine oil will not need to be drained in order to store the engine. Provided the correct specification of engine oil is used the engine can be stored for up to 6 months. For the correct specification of engine oil refer to this Operation and Maintenance Manual, "Fluid recommendations".
4. Remove the drive belt from the engine.

Sealed Coolant System

Ensure that the cooling system is filled with Perkins ELC, or an antifreeze that meets "ASTM D6210" specification.

Open Cooling System

Ensure that all cooling drain plugs have been opened. Allow the coolant to drain. Install the drain plugs. Place a vapor phase inhibitor into the system. The coolant system must be sealed once the vapor phase inhibitor has been introduced. The effect of the vapor phase inhibitor will be lost if the cooling system is open to the atmosphere.

For maintenance procedures refer to this Operation and Maintenance Manual.

Monthly Checks

The crankshaft must be rotated in order to change the spring loading on the valve train. Rotate the crankshaft more than 180 degrees. Visibly check for damage or corrosion to the engine.

Ensure that the engine is covered completely before storage. Log the procedure in the record for the engine.

Features and Controls

i05251301

Alarms and Shutoffs

Shutoffs

The shutoffs are electrically operated or mechanically operated. The electrically operated shutoffs are controlled by the ECM.

Shutoffs are set at critical levels for the following items:

- Operating temperature
- Operating pressure
- Operating level
- Operating rpm

The particular shutoff may need to be reset before the engine will start.

NOTICE

Always determine the cause of the engine shutdown. Make necessary repairs before attempting to restart the engine.

Be familiar with the following items:

- Types and locations of shutoff
- Conditions which cause each shutoff to function
- The resetting procedure that is required to restart the engine

Alarms

The alarms are electrically operated. The operation of the alarms is controlled by the ECM.

The alarm is operated by a sensor or by a switch. When the sensor or the switch is activated, a signal is sent to the ECM. An event code is created by the ECM. The ECM will send a signal in order to illuminate the lamp.

Your engine may be equipped with the following sensors or switches:

Coolant level – The low coolant level switch indicates when the coolant level is low.

Coolant temperature – The coolant temperature sensor indicates high jacket water coolant temperature.

Intake manifold air temperature – The intake manifold air temperature sensor indicates high intake air temperature.

Intake manifold pressure – The intake manifold pressure sensor checks the rated pressure in the engine manifold.

Fuel rail pressure – The fuel rail pressure sensor checks for high pressure or low pressure in the fuel rail.

Engine oil pressure – The engine oil pressure sensor indicates when oil pressure drops below rated system pressure, at a set engine speed.

Engine overspeed – The primary speed/timing sensor checks the engine speed. The alarm is activated at 3000 RPM.

Air filter restriction – The switch checks the air filter when the engine is operating.

User-defined switch – This switch can shut down the engine remotely.

Water in fuel switch – This switch checks for water in the primary fuel filter when the engine is operating.

Note: The sensing element of the coolant temperature switch must be submerged in coolant in order to operate.

Engines may be equipped with alarms in order to alert the operator when undesirable operating conditions occur.

NOTICE

When an alarm is activated, corrective measures must be taken before the situation becomes an emergency in order to avoid possible engine damage.

If corrective measures are not taken within a reasonable time, engine damage could result. The alarm will continue until the condition is corrected. The alarm may need to be reset.

Testing

Turning the keyswitch to the ON position will check the indicator lights on the control panel. All the indicator lights will be illuminated for 2 seconds after the keyswitch is operated. Replace suspect bulbs immediately.

Refer to Troubleshooting for more information.

i05537598

Gauges and Indicators

Your engine may not have the same gauges or all of the gauges that are described. For more information about the gauge package, see the OEM information.

Gauges provide indications of engine performance. Ensure that the gauges are in good working order. Determine the normal operating range by observing the gauges over a period.

Noticeable changes in gauge readings indicate potential gauge or engine problems. Problems may also be indicated by gauge readings that change even if the readings are within specifications. Determine and correct the cause of any significant change in the readings. Consult your Perkins dealer or your distributor Perkins for assistance.

Some engine applications are equipped with Indicator Lamps. Indicator lamps can be used as a diagnostic aid. There are two lamps. One lamp has an orange lens and the other lamp has a red lens.

These indicator lamps can be used in two ways:

- The indicator lamps can be used to identify the current operational status of the engine. The indicator lamps can also indicate that the engine has a fault. This system is automatically operated via the ignition switch.
- The indicator lamps can be used to identify active diagnostic codes.

Refer to the Troubleshooting Guide, "Indicator Lamps" for further information.

NOTICE

If no oil pressure is indicated, STOP the engine. If maximum coolant temperature is exceeded, STOP the engine. Engine damage can result.



Engine Oil Pressure – The oil pressure should be greatest after a cold engine is started. The typical engine oil pressure with SAE10W40 is 350 to 450 kPa (50 to 65 psi) at rated rpm.

A lower oil pressure is normal at low idle. If the load is stable and the gauge reading changes, perform the following procedure:

1. Remove the load.
2. Stop the engine.
3. Check and maintain the oil level.



Jacket Water Coolant Temperature – Typical temperature range is 83° to 95°C (181.4° to 171°F). The maximum allowable temperature at sea level with the pressurized cooling system at 48 kPa (7 psi) is 103 °C (217.4 °F). Higher temperatures may occur under certain conditions. The water temperature reading may vary according to load. The temperature reading should never exceed 7 °C (44.6 °F) below the boiling point for the pressurized system that is being used.

A 100 kPa (14.5 psi) radiator cap may be installed on the cooling system. The temperature of this cooling system must not exceed 112 °C (233.6 °F).

If the engine is operating above the normal range and steam becomes apparent, perform the following procedure:

1. Reduce the load and the engine rpm.
2. Determine if the engine must be shut down immediately or if the engine can be cooled by reducing the load.
3. Inspect the cooling system for leaks.



Tachometer – This gauge indicates engine speed (rpm). When the throttle control lever is moved to the full throttle position without load, the engine is running at high idle. The engine is running at the full load rpm when the throttle control lever is at the full throttle position with maximum rated load.

NOTICE

To help prevent engine damage, never exceed the high idle rpm. Overspeeding can result in serious damage to the engine. Operation at speeds exceeding high idle rpm should be kept to a minimum.



Ammeter – This gauge indicates the amount of charge or discharge in the battery charging circuit. Operation of the indicator should be to the "+" side of "0" (zero).



Fuel Level – This gauge indicates the fuel level in the fuel tank. The fuel level gauge operates when the "START/STOP" switch is in the "on" position.



Service Hour Meter – The gauge indicates total operating hours of the engine.

Indicator Lamps

There are four main indicator lamps that are available.

- Shutdown Lamp
- Warning Lamp
- Wait to Start Lamp
- Low Oil Pressure Lamp
- Fuel temperature

i02330192

For information, refer to this manual, “Monitoring System (Table for the Indicator Lamps)” for the sequence of operation of the shutdown lamp and the warning lamp.

The function of the wait to start lamp is automatically controlled at engine start-up.

The function of the low oil pressure lamp is controlled by the engine ECM. If low oil pressure is detected, the lamp will be illuminated. The reason for the illumination of the low-pressure lamp should be investigated immediately.

All lamps will illuminate for 2 seconds in order to check that the lamps are functioning when the keyswitch is turned to the ON position. If any of the lamps stay illuminated, the reason for illumination should be investigated immediately.

The glow plug warning lamp will flash in order to show that the engine is been held at low speed. This function will be performed at engine starting and the duration will depend on ambient temperature and engine temperature.

Instrument panels and Displays

In order to monitor the engine a wide variety of instrument panels are available. These instrument panels can contain the indicator lamps and the gauges for the application.

Also available are mini power displays and performance monitors. These displays and monitors can show the operator the following engine information.

- The system configuration parameters
- The customer specified parameters
- Diagnostic codes
- Event codes
- Coolant temperature
- Oil temperature
- Oil pressure
- Intake temperature
- Intake pressure

Monitoring System

Table 2

Warning Lamp	Shutdown Lamp	Lamp Status	Description of lamp status	Engine Status
ON	ON	Lamp check	When the engine start switch is turned to the "ON" position both lamps will illuminate for 2 seconds only.	The engine has not been started.
OFF	OFF	No faults	There are no active diagnostic faults.	The engine is running normally.
ON	OFF	Active diagnostic fault	An active diagnostic fault has been detected.	The engine is running normally.
ON	FLASHING	Active diagnostic fault	A serious active diagnostic fault has been detected and an engine derate has been invoked.	The engine is running but the engine has been derated.
FLASHING	OFF	Warning	One or more of the engine protection values has been exceeded.	The engine is running normally.
FLASHING	FLASHING	Derate and warning	One or more of the engine protection values has been exceeded.	The engine is running but the engine has been derated.
ON	ON	Engine shutdown	One or more of the engine protection values has been exceeded or a serious active diagnostic fault has been detected.	The engine is shutdown or shutdown is imminent.

i05546770

Monitoring System

WARNING

If the Shutdown mode has been selected and the warning indicator activates, engine shutdown may take as little as 20 seconds from the time the warning indicator is activated. Depending on the application, special precautions should be taken to avoid personal injury. The engine can be restarted following shutdown for emergency maneuvers, if necessary.

NOTICE

The Engine Monitoring System is not a guarantee against catastrophic failures. Programmed delays and derate schedules are designed to minimize false alarms and provide time for the operator to stop the engine.

The following parameters are monitored:

- Coolant temperature
- Intake manifold air temperature
- Intake manifold air pressure
- Oil pressure
- Pressure in the fuel rail
- Engine speed/timing

Programmable Options and Systems Operation

WARNING

If the Warning/Derate/Shutdown mode has been selected and the warning indicator activates, bring the engine to a stop whenever possible. Depending on the application, special precautions should be taken to avoid personal injury.

The engine can be programmed to the following modes:

“Warning”

The “Warning” lamp and the warning signal (orange lamp) turn “ON” and the warning signal is activated continuously in order to alert the operator that one or more of the engine parameters is not within normal operating range.

“Warning/Derate”

The “Diagnostic” lamp turns “ON” and the warning signal (red lamp) is activated. After the warning, the engine power will be derated. The warning lamp will begin to flash when the derating occurs.

The engine will be derated if the engine exceeds preset operational limits. The engine derate is achieved by restricting the amount of fuel that is available for each injection. The amount of this reduction of fuel is dependent on the severity of the fault that has caused the engine derate, typically up to a limit of 50%. This reduction in fuel results in a predetermined reduction in engine power.

“Warning/Derate/Shutdown”

The “Diagnostic” lamp turns “ON” and the warning signal (red lamp) is activated. After the warning, the engine power will be derated. The engine will continue at the rpm of the set derate until a shutdown of the engine occurs. The engine can be restarted after a shutdown for use in an emergency.

A shutdown of the engine may occur in as little as 20 seconds. The engine can be restarted after a shutdown for use in an emergency. However, the cause of the initial shutdown may still exist. The engine may shut down again in as little as 20 seconds.

If there is a signal for low oil pressure or for coolant temperature, there will be a two second delay in order to verify the condition.

For each of the programmed modes, refer to Troubleshooting Guide, “Indicator Lamps” for more information on Indicator Lamps.

For more information or assistance for repairs, consult your Perkins dealer or your Perkins distributor.

i05251914

Overspeed

An overspeed condition is detected by the Electronic Control Module (ECM). The event code E190 will be logged if the engine speed exceeds 3300 rpm. The “DIAGNOSTIC” lamp will indicate a diagnostic fault code. The diagnostic fault code will remain active until the engine speed drops to 2800 rpm.

i05488609

Sensors and Electrical Components

The illustrations within the following sections are typical location of the sensors or electrical components for an industrial engine. Specific engines may appear different due to differences in applications.

Operation Section
Sensors and Electrical Components

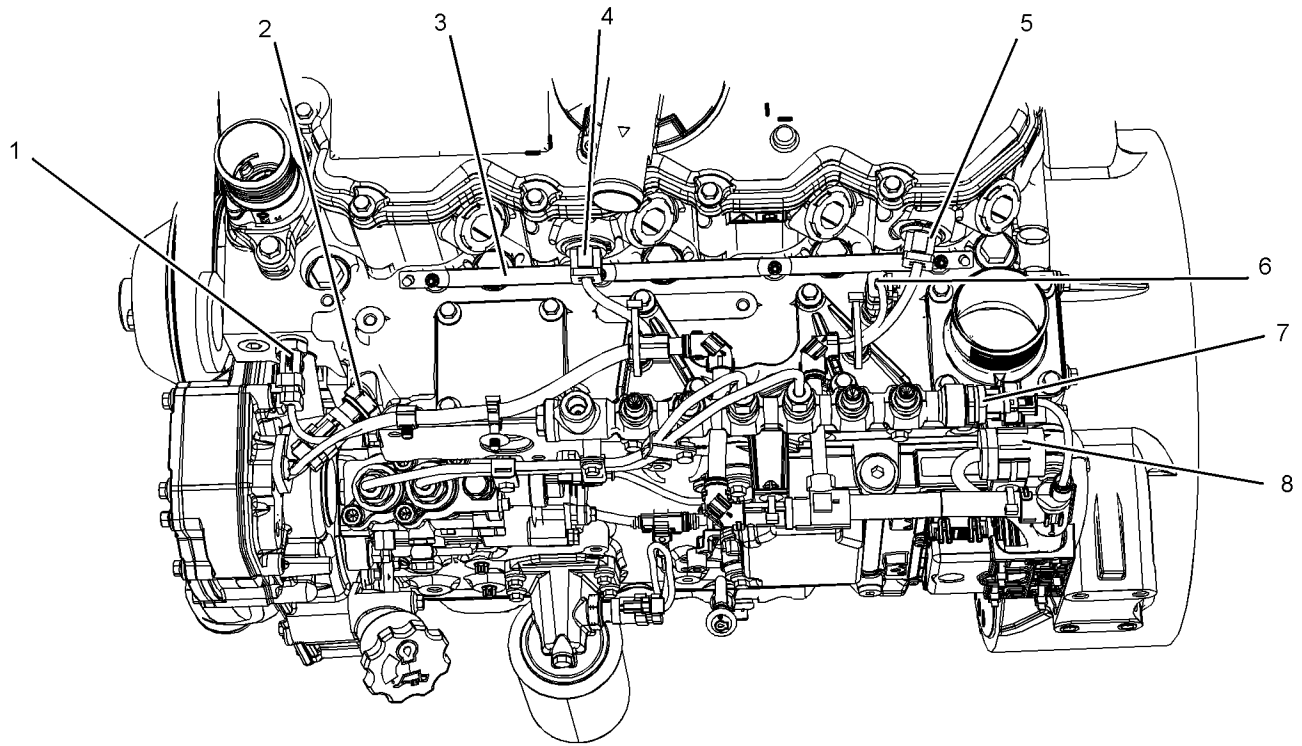

Illustration 27

g03470316

Typical example

- | | | |
|------------------------------------|--|-------------------------------|
| (1) Coolant Temperature Sensor | (4) Connector for Injectors 1 and Injector 2 | (7) Fuel Rail Pressure Sensor |
| (2) Inlet Manifold Pressure Sensor | (5) Connector for Injectors 3 and Injector 4 | (8) Diagnostic Connector |
| (3) Bus Bar for Glow Plugs | (6) Inlet Manifold Temperature Sensor | |

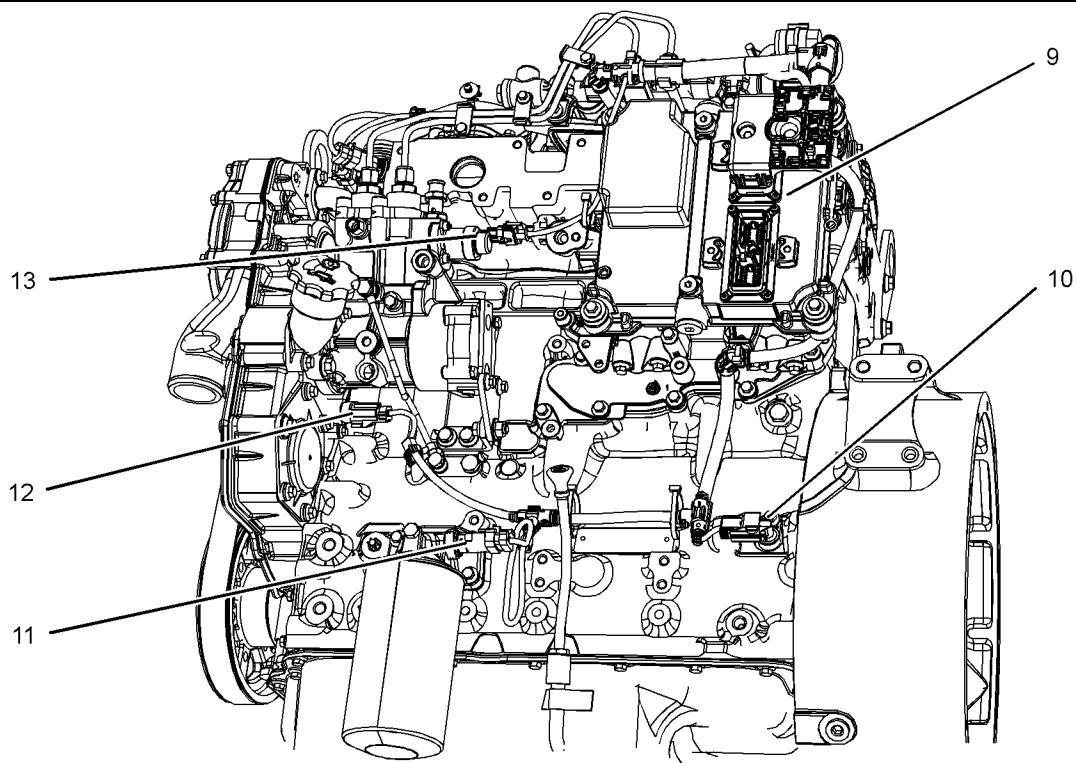

Illustration 28

g03470317

Typical example(9) Electronic Control Module
(10) Primary Speed/Timing sensor(11) Oil Pressure Sensor
(12) Secondary Speed/Timing sensor(13) Solenoid for the high-pressure fuel
pump

Operation Section
Sensors and Electrical Components

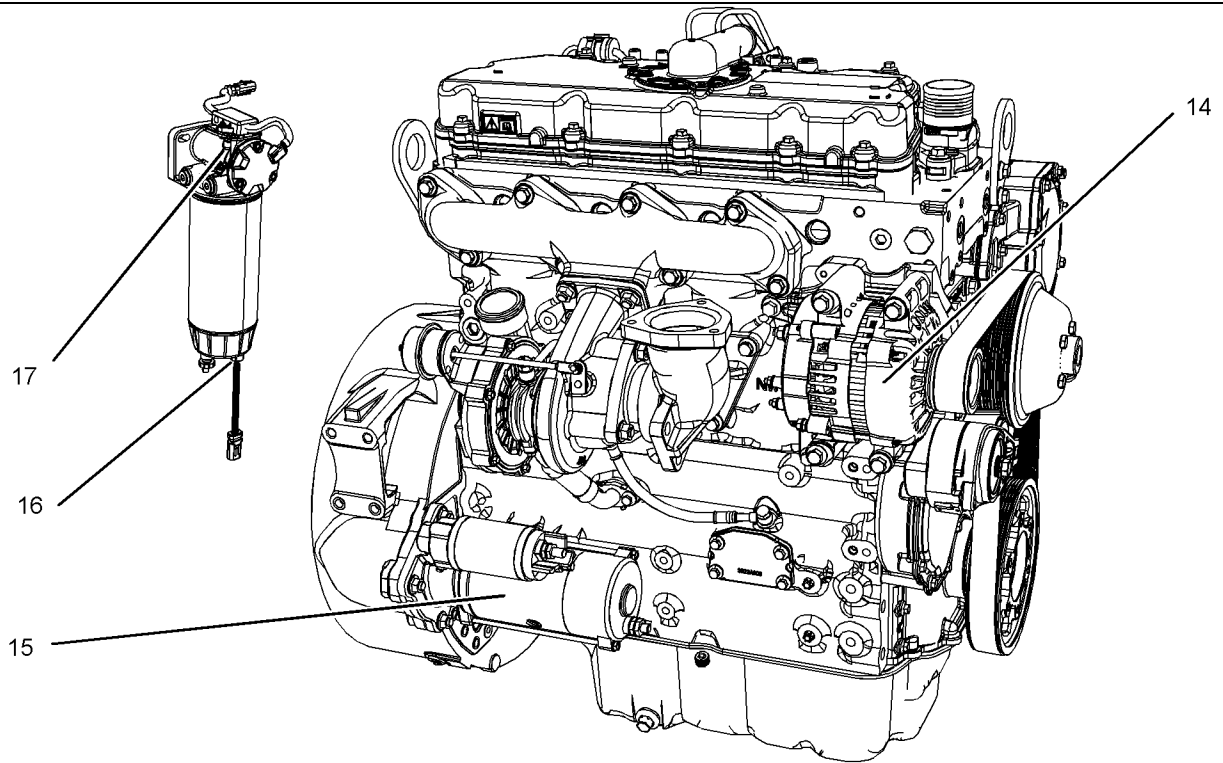

Illustration 29

g03470356

Typical example

(14) Alternator
(15) Starting Motor and solenoid

(16) Water in Fuel Switch
(17) Electric Fuel Pump/Priming Pump

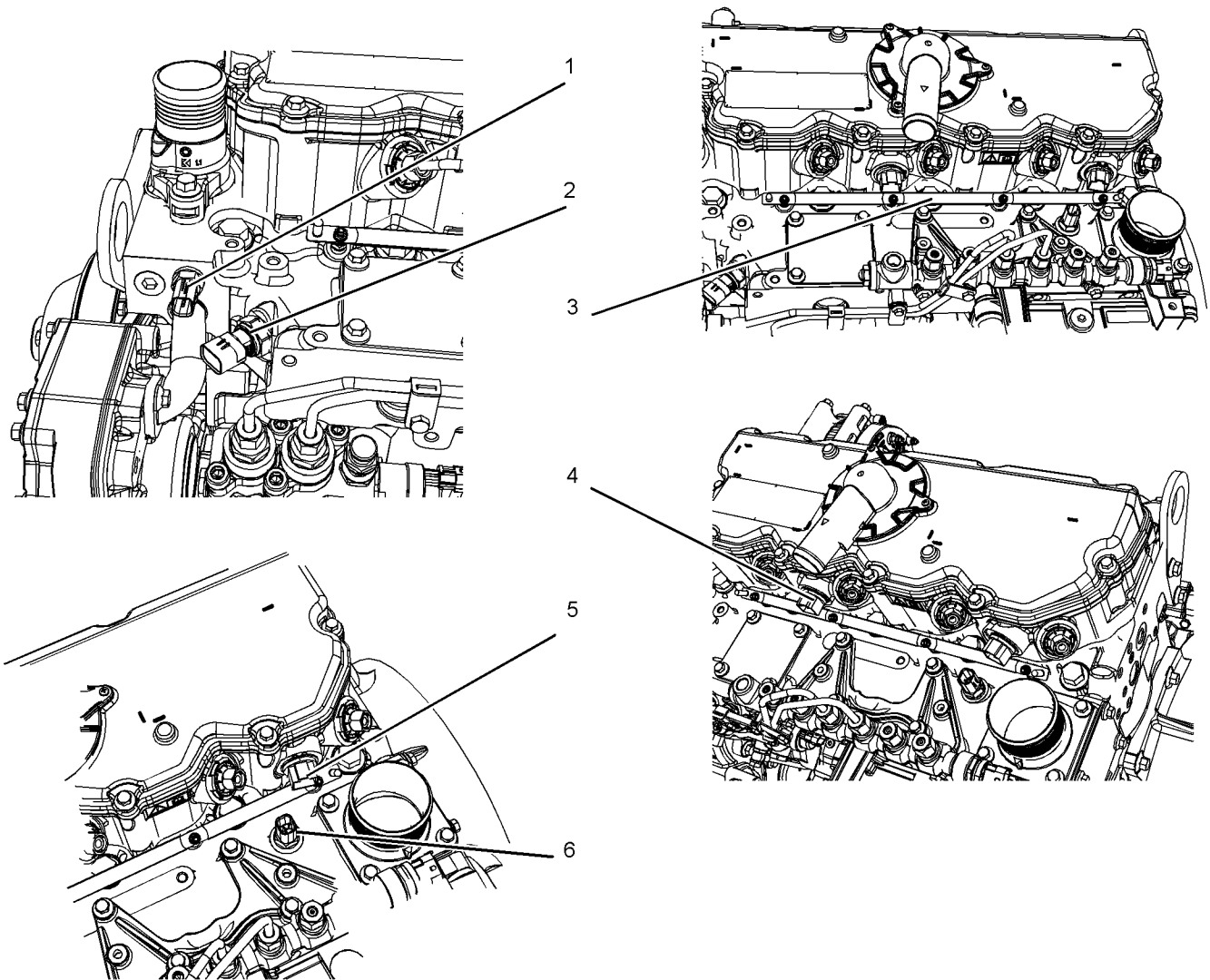

Illustration 30

g03471916

Typical example

(1) Coolant Temperature Sensor
(2) Inlet Manifold Pressure Sensor

(3) Bus Bar for Glow Plugs
(4) Connector for Injectors 1 and Injector 2

(5) Connector for Injectors 3 and Injector 4
(6) Inlet Manifold Temperature Sensor

Operation Section
Sensors and Electrical Components

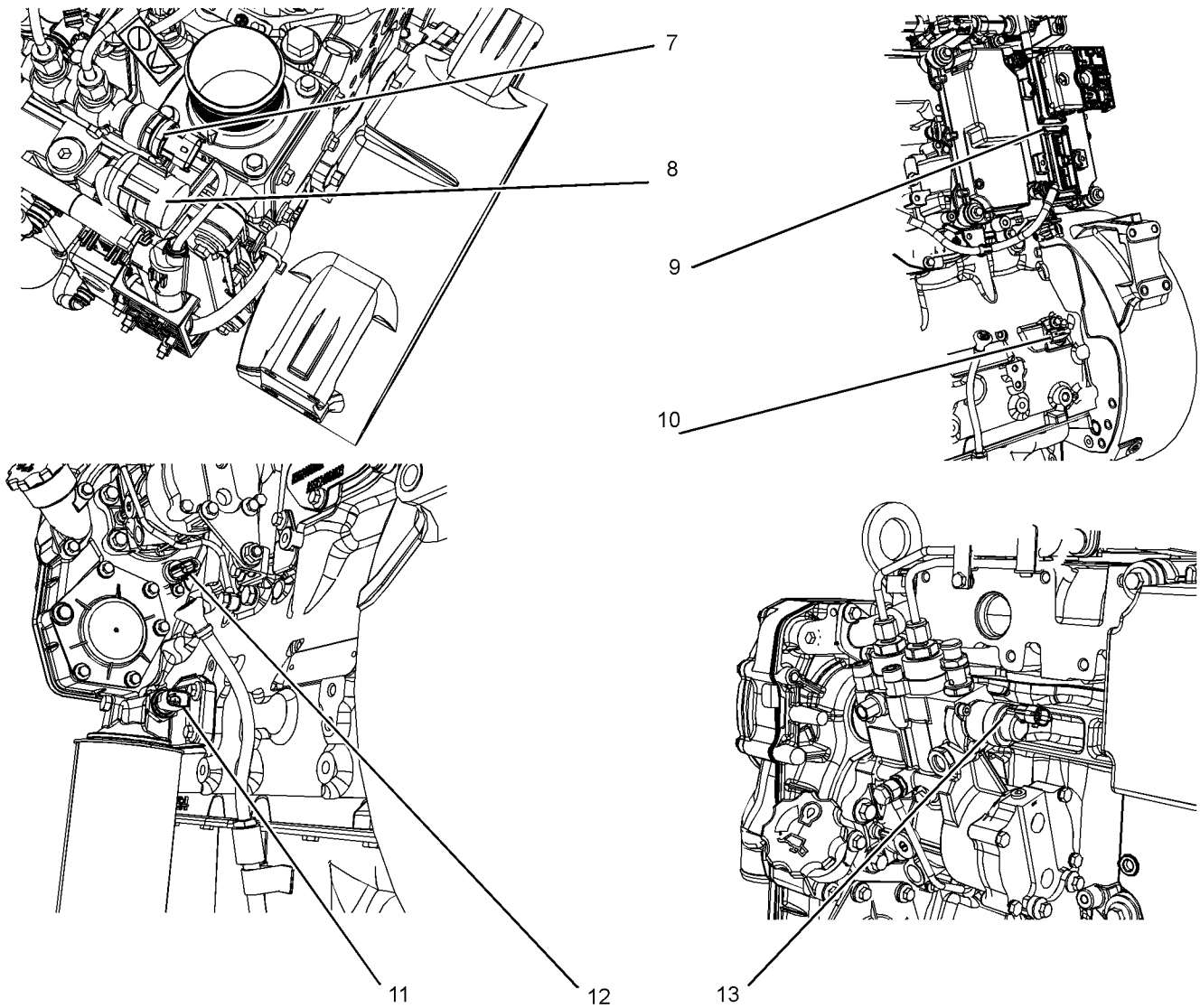

Illustration 31

g03471957

Typical example

(7) Fuel Rail Pressure Sensor
(8) Diagnostic Connector
(9) Electronic Control Module

(10) Primary Speed/Timing sensor
(11) Oil Pressure Sensor
(12) Secondary Speed/Timing sensor

(13) Solenoid for the high-pressure fuel pump

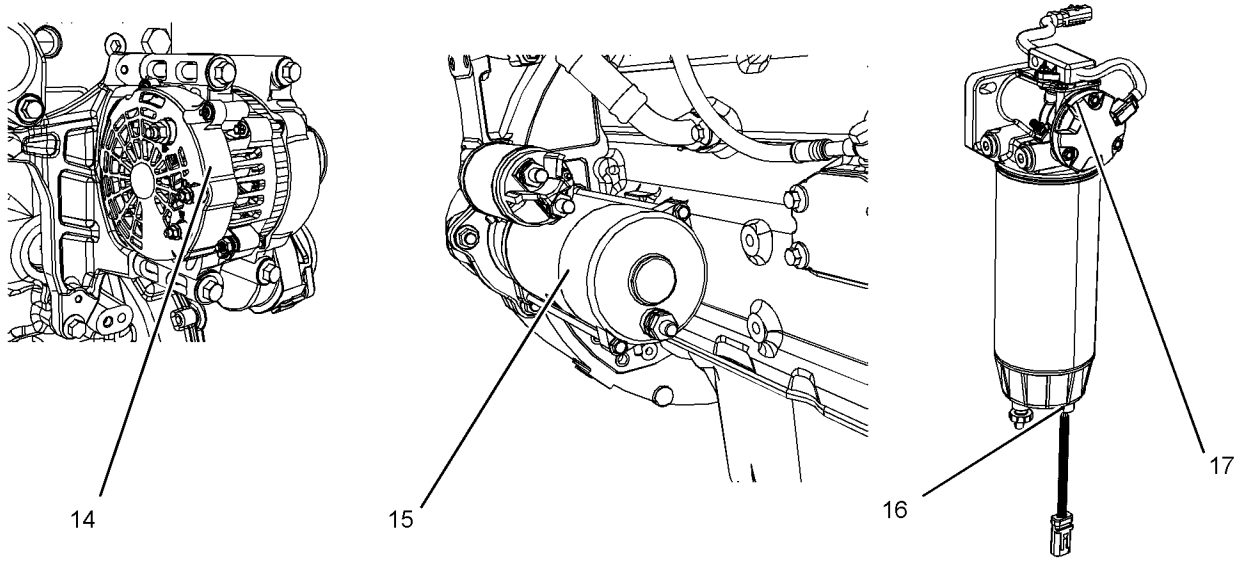

Illustration 32

g03474458

Typical example

- (14) Alternator
- (15) Starting Motor and solenoid

- (16) Water in Fuel Switch
- (17) Electric Fuel Pump/Priming Pump

Engine Diagnostics

i05537601

i02651093

Self-Diagnostics

Perkins electronic engines have the capability to perform a self-diagnostics test. When the system detects an active problem, a diagnostic lamp is activated. Diagnostic codes will be stored in permanent memory in the Electronic Control Module (ECM). The diagnostic codes can be retrieved by using the electronic service tool. Refer to Troubleshooting , “Electronic Service Tools” for further information.

Some installations have electronic displays that provide direct readouts of the engine diagnostic codes. Refer to the manual that is provided by the OEM for more information on retrieving engine diagnostic codes. Alternatively refer to Troubleshooting , “Indicator Lamps” for further information.

Active codes represent problems that currently exist. These problems should be investigated first.

Logged codes represent the following items:

- Intermittent problems
- Recorded events
- Performance history

The problems may have been repaired since the logging of the code. These codes do not indicate that a repair is needed. The codes are guides or signals when a situation exists. Codes may be helpful to troubleshoot problems.

When the problems have been corrected, the corresponding logged fault codes should be cleared.

i02651107

Diagnostic Lamp

A diagnostic lamp is used to indicate the existence of an active fault. Refer to Troubleshooting , “Indicator Lamps” for more information. A fault diagnostic code will remain active until the problem is repaired. The diagnostic code may be retrieved by using the electronic service tool. Refer to Troubleshooting , “Electronic Service Tools” for more information.

Diagnostic Flash Code Retrieval

“Diagnostic” Lamp

Use the “DIAGNOSTIC” lamp or an electronic service tool to determine the diagnostic flash code.

Use the following procedure to retrieve the flash codes if the engine is equipped with a “DIAGNOSTIC” lamp:

1. Move the keyswitch from the on/off two times within 3 seconds.

A flashing YELLOW lamp indicates a 3-digit code for the engine. The sequence of flashes represents the system diagnostic message. Count the first sequence of flashes in order to determine the first digit of the flash code. After a two second pause, the second sequence of flashes will identify the second digit of the flash code. After the second pause, the third sequence of flashes will identify the flash code.

Any additional flash codes will follow a pause. These codes will be displayed in the same manner. Flash Code 551 indicates that No Detected Faults have occurred since the ignition keyswitch has been turned to the ON position.

For further information, assistance for repairs, or troubleshooting, refer to the Service Manual or consult your Perkins distributor or Perkins dealer.

Table3 lists the flash codes and the table also gives a brief description of the flash codes.

Note: Table3 indicates the potential effect on engine performance with “ACTIVE” flash codes.

Some codes record events. Also, some codes may also indicate that a mechanical system needs attention. Troubleshooting is not required for code “551” . Code 001 will not display a flash code. Some codes will limit the operation or the performance of the engine.

Table 3 indicates the potential effect on the engine performance with active flash codes. Table 3 also forms a list of Electronic diagnostic codes and descriptions.

Table 3

Flash Codes for the Industrial Engine ⁽¹⁾							
Diagnostic Flash Code	Effect On Engine Performance ⁽²⁾					Suggested Operator Action	
	Description	Engine Misfire	Low Power	Reduced Engine Speed	Engine Shutdown	Service ⁽³⁾	Schedule a Service. ⁽⁴⁾
111	No. 1 Injector Fault	X	X			X	
112	No. 2 Injector Fault	X	X			X	
113	No. 3 Injector Fault	X	X			X	
114	No. 4 Injector Fault	X	X			X	
133	Intake Manifold Air Temperature sensor fault ⁽⁵⁾	X				X	
141	Primary Engine Speed/Timing Sensor Fault ⁽⁶⁾			X		X	
142	Secondary Engine Speed/Timing Sensor Fault					X	
143	Engine Timing Calibration Fault	X					X
144	Engine Operation Mode Selector Switch Fault		X			X	
151	Air Inlet Pressure Sensor		X			X	
154	Throttle Position Sensor Fault			X		X	
155	Secondary Throttle Position sensor Fault			X		X	
157	Engine Oil Pressure Sensor Fault		X			X	
159	Fuel Rail Pressure Sensor Fault		X			X	
162	Fuel Rail Pressure Valve Solenoid Fault		X	X		X	
168	Engine Coolant Temperature Sensor Fault					X	
169	Low Engine Coolant				X		X
177	Turbo Wastegate Actuator Fault			X			
185	High Exhaust Temperature		X			X	
197	Intake Manifold Boost Pressure Fault		X			X	
199	Glow Plug Start Relay Fault					X	
233	Ether Injection Control Solenoid					X	
245	Idle Validation Switch 1					X	
246	Idle Validation Switch 2					X	

(continued)

Operation Section Fault Logging

(Table 3, contd)

253	Engine Fuel Supply Pump Relay					X	
415	Software Mismatch			X	X	X	
426	Machine Security Module					X	
429	Ignition Key Switch Fault						X
511	ECM Power Supply Voltage Fault	X	X				
514	SAE J1939 Data Link Fault			X		X	
516	5 Volt Sensor DC Power Supply Fault		X		X	X	X
517	8 Volt Sensor DC Power Supply Fault		X				X
527	Customer/System Parameter Fault		X	X			X
551	System check No faults detected						

- (1) If warning lamps are installed, refer to this table. For installations that have electronic displays, refer to the OEM for information.
- (2) An "X" indicates that the effect on engine performance may occur if the code is active.
- (3) The operator should go to the nearest location that has a qualified service program.
- (4) Schedule Service: The problem should be investigated when the operator has access to a qualified service program.
- (5) These Flash Codes may affect the system under specific environmental conditions such as engine start-up at cold temperature and cold-weather operation at high altitudes.
- (6) If the primary engine speed/timing sensor fails there is no automatic protection against reverse running. In this event, Stop the engine immediately. Turn the keyswitch to the "OFF" position. In order to check the correct operation of the sensor, refer to Troubleshooting, "Speed/Timing - Test".

i01902949

Fault Logging

The system provides the capability of Fault Logging. When the Electronic Control Module (ECM) generates an active diagnostic code, the code will be logged in the memory of the ECM. The codes that have been logged by the ECM can be identified by the electronic service tool. The active codes that have been logged will be cleared when the fault has been rectified or the fault is no longer active. The following logged faults can not be cleared from the memory of the ECM without using a factory password: Overspeed, low engine oil pressure and high engine coolant temperature.

i03554534

Engine Operation with Active Diagnostic Codes

If a diagnostic lamp illuminates during normal engine operation, the system has identified a situation that is not within the specification. Use electronic service tools to check the active diagnostic codes.

Note: If the customer has selected "DERATE" and if there is a low oil pressure condition, the Electronic Control Module (ECM) will limit the engine power until the problem is corrected. If the oil pressure is within the normal range, the engine may be operated at the rated speed and load. However, maintenance should be performed as soon as possible.

The active diagnostic code should be investigated. The cause of the problem should be corrected as soon as possible. If the cause of the active diagnostic code is repaired and there is only one active diagnostic code, the diagnostic lamp will turn off.

Operation of the engine and performance of the engine can be limited as a result of the active diagnostic code that is generated. Acceleration rates may be significantly slower. Refer to the Troubleshooting Guide for more information on the relationship between these active diagnostic codes and engine performance.

i01902995

Engine Operation with Intermittent Diagnostic Codes

If a diagnostic lamp illuminates during normal engine operation and the diagnostic lamp shuts off, an intermittent fault may have occurred. If a fault has occurred, the fault will be logged into the memory of the Electronic Control Module (ECM).

In most cases, it is not necessary to stop the engine because of an intermittent code. However, the operator should retrieve the logged fault codes and the operator should reference the appropriate information in order to identify the nature of the event. The operator should log any observation that could have caused the lamp to light.

- Low power
- Limits of the engine speed
- Excessive smoke, etc

This information can be useful to help troubleshoot the situation. The information can also be used for future reference. For more information on diagnostic codes, refer to the Troubleshooting Guide for this engine.

i05495474

Configuration Parameters

The engine electronic control module (ECM) has two types of configuration parameters. The system configuration parameters and the customer specified parameters.

The electronic service tool is required in order to alter the configuration parameters.

System Configuration Parameters

System configuration parameters affect the emissions of the engine or the power of the engine. System configuration parameters are programmed at the factory. Normally, system configuration parameters would never require changing through the life of the engine. System configuration parameters must be reprogrammed if an ECM is replaced. System configuration parameters do not require reprogrammed if the ECM software is changed. Factory passwords are required to change these parameters.

Operation Section
Configuration Parameters

Table 4

System Configuration Parameters	
Configuration Parameters	Record
Engine Serial Number	
Rating	
Full Load Setting	
Full Torque Setting	
ECM Software Release Date	

Customer Specified Parameters

Customer specified parameters allow the engine to be configured to the exact needs of the application.

The electronic service tool is required in order to alter the customer configuration parameters.

Customer parameters may be changed repeatedly as operational requirements change.

Table 5

Customer Specified Parameters	
Specified Parameters	Record
ECM Identification Parameters	
ECM Serial Number	
Software Group Part Number	
Software Group Release Date	
Software Group Description	
Selected Engine Rating	
Rating Number	
Speed Control	
Low Idle Speed	
Engine Configuration Parameters	
Glow Plug Start Aid Installation Status	
Ether Solenoid Configuration	
Engine Idle Shutdown	
Minimum Ambient Air Temperature	
Maximum Ambient Air Temperature	
Shutdown Enable Status	
Shutdown Delay Time	
Ambient Temperature Override Enable Status	
PTO and Throttle Lock Parameters	
Throttle Lock Feature Installation Status	

(continued)

(Table 5, contd)

PTO Mode	
Throttle Lock Engine Set Speed 1	
Throttle Lock Engine Set Speed 2	
Throttle Lock Increment Speed Ramp Rate	
Throttle Lock Decrement Speed Ramp Rate	
Throttle Lock Engine Set Speed Increment	
Throttle Lock Engine Set Speed Decrement	
Miscellaneous	
Monitoring Mode Shutdowns	
Monitoring Mode Derates	
Limp Home Desired Engine Speed	
Limp Home Engine Speed Ramp Rate	
Engine Acceleration Rate	
Engine Speed Decelerating Ramp Rate	
Intermediate Engine Speed	
Fan Control	
Engine Fan Control	
Engine Fan Type Configuration	
Pulley Ratio	
Temperature Error Increasing Hysteresis	
Temperature Error Decreasing Hysteresis	
Current Ramp Rate	
Fan Speed (Proportional) Gain Percentage	
Fan Speed (Integral) Stability Percentage	
Top Fan Speed	
Minimum Desired Fan Speed	
Solenoid Minimum Current	
Solenoid Maximum Current	
Solenoid Dither Frequency	
Solenoid Dither Amplitude (Peak-to-Peak)	
Fan Temperatures	
Charge Air Cooler Outlet Temperature Input Enable	
Maximum Air Flow Charge Air Cooler Outlet Temperature	
Minimum Air Flow Charge Air Cooler Outlet Temperature	
Coolant Temperature Input Enable Status	
Maximum Air Flow Coolant Temperature	

(continued)

Operation Section
Configuration Parameters

(Table 5, contd)

Minimum Air Flow Coolant Temperature	
Transmission Oil Temperature Input Enable Status	
Hydraulic Oil Temperature Input Enable Status	
Auxiliary #1 Temperature Input Enable Status	
Auxiliary #2 Temperature Input Enable Status	
Configurable Inputs	
Coolant Level Sensor	
Air Filter Restriction Switch Installation Status	
Air Filter Restriction Switch Configuration	
Water in Fuel Switch Installation Status	
User Defined Switch Installation Status	
Auxiliary Temperature Sensor Installation Status	
Auxiliary Pressure Sensor Installation Status	
Engine Charge Air Cooler #1 Outlet Temperature Sensor Installation Status	
Engine Oil Level Sensor Installation Status	
J1939 Continuous Fault Handling	
Remote Torque Speed Control Enable Status	
System Settings	
System Operating Voltage Configuration	
Security Access Parameters	
Customer Password #1	
Customer Password #2	
CAN Communication Protocol Write Security	
CAN Communication Protocol Read Security	
Total Tattletale	

Engine Starting

i05570730

i02837427

Before Starting Engine

Perform the required daily maintenance and other periodic maintenance before the engine is started. Inspect the engine compartment. This inspection can help prevent major repairs at a later date. Refer to the Operation and Maintenance Manual, "Maintenance Interval Schedule" for more information.

- Ensure that the engine has an adequate fuel supply.
- Open the fuel supply valve (if equipped).

NOTICE

All valves in the fuel return line must be open before and during engine operation to help prevent high fuel pressure. High fuel pressure may cause filter housing failure or other damage.

If the engine has not been started for several weeks, fuel may have drained from the fuel system. Air may have entered the filter housing. Also, when fuel filters have been changed, some air pockets will be trapped in the engine. In these instances, prime the fuel system. Refer to the Operation and Maintenance Manual, "Fuel System - Prime" for more information on priming the fuel system.

WARNING

Engine exhaust contains products of combustion which may be harmful to your health. Always start and operate the engine in a well ventilated area and, if in an enclosed area, vent the exhaust to the outside.

- Do not start the engine or move any of the controls if there is a "DO NOT OPERATE" warning tag or similar warning tag attached to the start switch or to the controls.
- Reset all of the shutoffs or alarm components.
- Ensure that any driven equipment has been disengaged. Minimize electrical loads or remove any electrical loads.

Cold Weather Starting

WARNING

Do not use aerosol types of starting aids such as ether. Such use could result in an explosion and personal injury.

Startability will be improved at temperatures below -18°C (0°F) from the use of a jacket water heater or extra battery capacity.

When Group 2 diesel fuel is used, the following items provide a means of minimizing starting problems and fuel problems in cold weather: Engine oil pan heaters, jacket water heaters, fuel heaters and fuel line insulation.

Use the procedure that follows for cold weather starting.

Note: Do not adjust the engine speed control during start-up. The electronic control module (ECM) will control the engine speed during start-up.

Ensure that the correct oil specification, oil grade, and the correct fuel are used before starting. Refer to this Operation and Maintenance Manual, "Fluid Recommendation".

1. Disengage any driven equipment.
2. Turn the keyswitch to the RUN position. Leave the keyswitch in the RUN position until the warning light for the glow plugs is extinguished.

NOTICE

Do not engage the starting motor when flywheel is turning. Do not start the engine under load.

If the engine fails to start within 30 seconds, release the starter switch or button and wait two minutes to allow the starting motor to cool before attempting to start the engine again.

3. When the warning light for the glow plugs is extinguished, turn the keyswitch to the START position in order to engage the electric starting motor and crank the engine.

Note: The operating period of the warning light for the glow plugs will change due to the temperature of the engine.

4. Allow the keyswitch to return to the RUN position after the engine starts.
5. Repeat step 2 through step 4 if the engine fails to start.

Note: After starting, the engine may be held at low speed for a duration between 1 and 25 seconds to allow engine systems to stabilize. The duration will depend on ambient temperature, time since last run and other factors. The glow plug warning light will flash in order to indicate that the engine is been held at low speed.

6. The engine should not be raced in order to speed up the warm-up process. Allow the engine to idle for 3 to 5 minutes, or allow the engine to idle until the water temperature indicator begins to rise. When idling after the engine has started in cold weather, increase the engine rpm from 1000 to 1200 rpm. This operation will warm up the engine more quickly. Maintaining an elevated low idle speed for extended periods will be easier with the installation of a hand throttle.
7. Operate the engine at low load until all systems reach operating temperature. Check the gauges during the warm-up period.

i06588238

Starting the Engine

Note: Do not adjust the engine speed control during start-up. The electronic control module (ECM) will control the engine speed during start-up.

Starting the Engine

1. Disengage any equipment that is driven by the engine.
2. Turn the keyswitch to the RUN position. Leave the keyswitch in the RUN position until the warning light for the glow plugs is extinguished.
3. When the warning light for the glow plugs is extinguished, turn the keyswitch to the START position to engage the electric starting motor and crank the engine.

Note: The operating period of the warning light for the glow plugs will change due to the temperature of the engine.

NOTICE

Do not engage the starting motor when flywheel is turning. Do not start the engine under load.

If the engine fails to start within 30 seconds, release the starter switch or button and wait two minutes to allow the starting motor to cool before attempting to start the engine again.

4. Allow the keyswitch to return to the RUN position after the engine starts.
5. Repeat step 2 through step 4 if the engine fails to start.
6. After starting, the engine may be held at low speed for a duration between 1 and 25 seconds to allow engine systems to stabilize. The duration will depend on ambient temperature, time since last run and other factors. The glow plug warning light will flash to indicate that the engine is been held at low speed.

Refer to this Operation and Maintenance Manual, After Starting Engine for more information.

Constant Speed Engines

After starting, the engine may be held at low speed for a duration between 1 and 25 seconds to allow engine systems to stabilize. The duration will depend on ambient temperature, time since last run and other factors. The glow plug warning light will flash to indicate that the engine is been held at low speed.

The engine should be allowed to operate at idle for 3 to 5 minutes before applying the load. Once the load is applied, the engine will operate at the rated speed that has been programmed. The engine will stay at the rated speed and will not return to idle, even if the load has been removed.

If necessary, refer to the instructions that are provided by the OEM to stop the engine.

i08134367

Starting with Jump Start Cables

(Do Not Use This Procedure in Hazardous Locations that have Explosive Atmospheres)

WARNING

The connection of battery cables to a battery and the disconnection of battery cables from a battery may cause an explosion which may result in injury or death. The connection and the disconnection of other electrical equipment may also cause an explosion which may result in injury or death. The procedures for the connection and the disconnection of battery cables and other electrical equipment should only be performed in a nonexplosive atmosphere.

⚠ WARNING

Improper jump start cable connections can cause an explosion resulting in personal injury.

Prevent sparks near the batteries. Sparks could cause vapors to explode. Do not allow jump start cable ends to contact each other or the engine.

Note: If possible, first diagnose the reason for the starting failure. Refer to Troubleshooting, “Engine Will Not Crank and Engine Cranks But Will Not Start” for further information. Make any necessary repairs. If the engine will not start only due to the condition of the battery, either charge the battery, or start the engine by using another battery with jump-start cables. The condition of the battery can be rechecked after the engine has been switched OFF.

NOTICE

Never attempt to start an engine from an external power source such as electric welding equipment, which has a voltage that is unsuitable for engine starting and will damage the electrical system.

For 904D-E28T industrial engines, use a 12 VDC battery source to start the engine.

For 904D-E36TA industrial engines, ensure that a 12 VDC or 24 VDC battery source is used to start the engine.

NOTICE

Using a battery source with the same voltage as the electric starting motor. Use ONLY equal voltage for jump starting. The use of higher voltage will damage the electrical system.

Do not reverse the battery cables. The alternator can be damaged. Attach ground cable last and remove first.

Turn all electrical accessories OFF before attaching the jump start cables.

Ensure that the main power switch is in the OFF position before attaching the jump start cables to the engine being started.

1. Turn the start switch on the stalled engine to the OFF position. Turn off all the engines accessories.
2. Connect one positive end of the jump-start cable to the positive cable terminal of the discharged battery. Connect the other positive end of the jump-start cable to the positive cable terminal of the electrical source.

3. Connect one negative end of the jump-start cable to the negative cable terminal of the electrical source. Connect the other negative end of the jump-start cable to the engine block or to the chassis ground. This procedure helps to prevent potential sparks from igniting the combustible gases that are produced by some batteries.

Note: The engine ECM must be powered before the starting motor is operated or damage can occur.

4. Start the engine in the normal operating procedure. Refer to this Operation and Maintenance Manual, “Starting the Engine”.
5. Immediately after the engine is started, disconnect the jump-start cables in reverse order.

After jump starting, the alternator may not be able to recharge fully batteries that are severely discharged. The batteries must be replaced or charged to the proper voltage with a battery charger after the engine is stopped. Many batteries which are considered unusable are still rechargeable. Refer to Operation and Maintenance Manual, “Battery - Replace” and Testing and Adjusting Manual, “Battery - Test”.

i05495593

After Starting Engine

After starting, the engine may be held at low speed for a duration between 1 and 25 seconds to allow engine systems to stabilize. The duration will depend on ambient temperature, time since last run and other factors.

Note: In ambient temperatures from 0 to 60°C (32 to 140°F), the warm-up time is approximately 3 minutes. In temperatures below 0°C (32°F), additional warm-up time may be required.

When the engine idles during warm-up, observe the following conditions:

Do not check the high-pressure fuel lines with the engine or the starting motor in operation. If you inspect the engine in operation, always use the proper inspection procedure in order to avoid a fluid penetration hazard. Refer to Operation and Maintenance Manual, “General hazard Information”.

- Check for any fluid or for any air leaks at idle rpm and at one-half full rpm (no load on the engine) before operating the engine under load. This check may not possible in some applications.
- Allow the engine to idle for 3 to 5 minutes, or allow the engine to idle until the water temperature indicator begins to rise. Check all gauges during the warm-up period.

Operation Section
After Starting Engine

Constant speed engines should be allowed to operate at low idle for 3 minutes before used at operational speed. If the low idle option is not available, then operate the engine at operational speed with no load for 2 minutes.

Note: Gauge readings should be observed and the data should be recorded frequently while the engine is operating. Comparing the data over time will help to determine normal readings for each gauge. Comparing data over time will also help detect abnormal operating developments. Significant changes in the readings should be investigated.

Engine Operation

i05570732

Engine Operation

Proper operation and maintenance are key factors in obtaining the maximum life and economy of the engine. If the directions in the Operation and Maintenance Manual are followed, costs can be minimized and engine service life can be maximized.

The time that is needed for the engine to reach normal operating temperature can be less than the time taken for a walk-around inspection of the engine.

When idling after the engine is started in cold weather, increase the engine rpm from 1000 to 1200 rpm. This idling will warm up the engine more quickly. Maintaining an elevated low idle speed for extended periods will be easier with the installation of a hand throttle. The engine should not be "raced" in order to speed up the warm-up process.

Gauge readings should be observed and the data should be recorded frequently while the engine is operating. Comparing the data over time will help to determine normal readings for each gauge. Comparing data over time will also help detect abnormal operating developments. Significant changes in the readings should be investigated.

i05277332

Fuel Conservation Practices

The efficiency of the engine can affect the fuel economy. Perkins design and technology in manufacturing provides maximum fuel efficiency in all applications. Follow the recommended procedures in order to attain optimum performance for the life of the engine.

- Avoid spilling fuel.

Fuel expands when the fuel is warmed up. The fuel may overflow from the fuel tank. Inspect fuel lines for leaks. Repair the fuel lines, as needed.

- Be aware of the properties of the different fuels. Use only the recommended fuels. Refer to the Operations and Maintenance Manual, "Fuel Recommendations" for further information.
- Avoid unnecessary idling.

Shut off the engine rather than idle for long periods of time.

- Observe the service indicator frequently. Keep the air cleaner elements clean.
- Ensure that the turbocharger is operating correctly so that the proper air/fuel ratio is maintained. Clean exhaust indicates proper functioning.
- Maintain a good electrical system.

One faulty battery cell will overwork the alternator. This fault will consume excess power and excess fuel.

- Ensure that the belts are properly adjusted. The belts should be in good condition. Refer to the Specifications manual for further information.
- Ensure that all of the connections of the hoses are tight. The connections should not leak.
- Ensure that the driven equipment is in good working order.
- Cold engines consume excess fuel. Utilize heat from the jacket water system and the exhaust system, when possible. Keep cooling system components clean and keep cooling system components in good repair. Never operate the engine without water temperature regulators. All of these items will help maintain operating temperatures.

Cold Weather Operation

i05537701

Cold Weather Operation

Perkins Diesel Engines can operate effectively in cold weather. During cold weather, the starting and the operation of the diesel engine is dependent on the following items:

- The type of fuel that is used
- The viscosity of the engine oil
- The operation of the glow plugs
- Optional Cold starting aid
- Battery condition

This section will cover the following information:

- Potential problems that are caused by cold-weather operation
- Suggest steps which can be taken in order to minimize starting problems and operating problems when the ambient air temperature is between 0° to -40 °C (32° to 40 °F).

The operation and maintenance of an engine in freezing temperatures is complex . This complexity is because of the following conditions:

- Weather conditions
- Engine applications

Recommendations from your Perkins dealer or your Perkins distributor are based on past proven practices. The information that is contained in this section provides guidelines for cold-weather operation.

Hints for Cold Weather Operation

- If the engine will start, operate the engine until a minimum operating temperature of 80° C (176° F) is achieved. Achieving operating temperature will help prevent the intake valves and exhaust valves from sticking.
- The cooling system and the lubrication system for the engine do not lose heat immediately upon shutdown. This means that an engine can be shut down for a period and the engine can still have the ability to start readily.

- Install the correct specification of engine lubricant before the beginning of cold weather. Refer to this Operation and Maintenance Manual, "Fluid Recommendations" for the recommended viscosity of oil.
- Check all rubber parts (hoses, fan drive belts,) weekly.
- Check all electrical wiring and connections for any fraying or damaged insulation.
- Keep all batteries fully charged and warm by ensuring that the engine is allowed to operate at normal operating temperature.
- Fill the fuel tank at the end of each shift.
- Drain the water from the fuel system. Refer to this Operation and Maintenance Manual, "Fuel System Primary Filter/Water Separator - Drain"
- Check the air cleaners and the air intake daily. Check the air intake more often when you operate in snow.
- Ensure that the glow plugs are in working order. Refer to Troubleshooting, "Glow Plug Starting Aid-Test".

WARNING

Personal injury or property damage can result from alcohol or starting fluids.

Alcohol or starting fluids are highly flammable and toxic and if improperly stored could result in injury or property damage.

WARNING

Do not use aerosol types of starting aids such as ether. Such use could result in an explosion and personal injury.

- For jump starting with cables in cold weather, refer to the Operation and Maintenance Manual, "Starting with Jump Start Cables." for instructions.

Viscosity of the Engine Lubrication Oil

Correct engine oil viscosity is essential. Oil viscosity affects lubrication properties and wear protection that the oil provides for the engine. Refer to this Operation and Maintenance Manual, "Fluid Recommendations" for the recommended viscosity of oil.

Recommendations for the Coolant

Provide cooling system protection for the lowest expected outside temperature. Refer to this Operation and Maintenance Manual, "Fluid Recommendations" for the recommended coolant mixture.

In cold weather, check the coolant often for the correct glycol concentration in order to ensure adequate freeze protection.

Engine Block Heaters

Engine block heaters (if equipped) heat the engine jacket water that surrounds the combustion chambers. This heat provides the following functions:

- Startability is improved.
- Warm up time is reduced.

An electric block heater can be activated once the engine is stopped. A block heater can be 110 V dc or 240 V dc. The output can be 750/1000W. Consult your Perkins dealer or your Perkins distributor for more information.

Idling the Engine

After starting the engine, the engine speed will be governed for a maximum period of 25 seconds. When idling after the engine is started in cold weather, increase the engine rpm from 1000 to 1200 rpm. This idling will warm up the engine more quickly. Maintaining an elevated low idle speed for extended periods will be easier with the installation of a hand throttle. The engine should not be "raced" in order to speed up the warm-up process.

While the engine is idling, the application of a light load (parasitic load) will assist in achieving the minimum operating temperature. The minimum operating temperature is 80° C (176° F).

Constant speed engines should be allowed to operate at low idle for 3 minutes before used at operational speed. If the low idle option is not available, then operate the engine at operational speed with no load for 2 minutes.

Recommendations for Coolant Warm Up

Warm up an engine that has cooled below normal operating temperatures due to inactivity. This warm-up should be performed before the engine is returned to full operation. During operation in very cold temperature conditions, damage to engine valve mechanisms can result from engine operation for short intervals. This damage can happen if the engine is started and the engine is stopped many times without being operated in order to warm up completely.

When the engine is operated below normal operating temperatures, fuel and oil are not burned completely in the combustion chamber. This fuel and oil causes soft carbon deposits to form on the valve stems. Generally, the deposits do not cause problems and the deposits are burned off during operation at normal engine operating temperatures.

When starting and stopping an engine many times without being operated in order to warm up completely, the carbon deposits become thicker. This starting and stopping can cause the following problems:

- Free operation of the valves is prevented.
- Valves become stuck.
- Pushrods may become bent.
- Other damage to valve train components can result.

For this reason, when the engine is started, the engine must be operated until the coolant temperature is 80° C (176° F) minimum. Carbon deposits on the valve stems will be kept at a minimum and the free operation of the valves and the valve components will be maintained.

The engine must be thoroughly warmed in order to keep other engine parts in better condition. The service life of the engine will be generally extended. Lubrication will be improved. There will be less acid and less sludge in the oil. This condition will provide longer service life for the engine bearings, the piston rings, and other parts. However, limit unnecessary idle time to 10 minutes in order to reduce wear and unnecessary fuel consumption.

The Water Temperature Regulator and Insulated Heater Lines

The engine is equipped with a water temperature regulator. When the engine coolant is below the correct operating temperature, jacket water circulates through the engine cylinder block and into the engine cylinder head. The coolant then returns to the cylinder block via an internal passage that bypasses the valve of the coolant temperature regulator. This return ensures that coolant flows around the engine under cold operating conditions. The water temperature regulator begins to open when the engine jacket water has reached the correct minimum operating temperature. As the jacket water coolant temperature rises above the minimum operating temperature, the water temperature regulator opens further allowing more coolant through the radiator to dissipate excess heat.

The progressive opening of the water temperature regulator operates the progressive closing of the bypass passage between the cylinder block and head. This action ensures maximum coolant flow to the radiator in order to achieve maximum heat dissipation.

Note: Do not restrict the air flow. Restriction of the air flow can damage the fuel system. Perkins discourages the use of all air flow restriction devices such as radiator shutters. Restriction of the air flow can result in the following: high exhaust temperatures, power loss, excessive fan usage and reduction in fuel economy.

A cab heater is beneficial in very cold weather. The feed from the engine and the return lines from the cab should be insulated in order to reduce heat loss to the outside air.

Recommendation for Crankcase Breather Protection

Crankcase ventilation gases contain a large quantity of water vapor. This water vapor can freeze in cold ambient conditions and can plug or damage the crankcase ventilation system. If the engine is operated in temperatures below -25°C (-13°F), measures must be taken to prevent freezing and plugging of the breather system. An open breather system will operate more effectively in temperatures below -25°C (-13°F). In extreme weather conditions insulating the breather hose will help to protect the system.

Consult with your Perkins dealer or your Perkins distributor for the recommended breather components for operation from -25° to -40°C (-13° to -72°F).

i07818744

Fuel and the Effect from Cold Weather

Note: Only use grades of fuel that are recommended by Perkins. Refer to this Operation and Maintenance Manual, "Fluid Recommendations".

Properties of the diesel fuel can have a significant effect on the engine cold start capability. It is critical that the low temperature properties of diesel fuel are acceptable for the minimum ambient temperature the engine is expected to see in operation.

Following properties are used to define fuels low temperature capability:

- Cloud point
- Pour point
- Cold Filter Plugging Point (CFPP)

The cloud point of the fuel is the temperature at which waxes naturally found in the diesel fuel begin to form crystals. The cloud point of the fuel must be below lowest ambient temperature to prevent filters from plugging.

Pour point is the last temperature before the fuel flow stops and waxing of the fuel will start.

Cold Filter Plugging Point (CFPP) is a temperature at which a particular fuel will pass through a standardized filtration device. This CFPP gives an estimate of the lower operability temperature of fuel

Be aware of these properties when diesel fuel is purchased. Consider the average ambient air temperature for the engines application. Engines that are fueled in one climate may not operate well if the engines are shipped to colder climate. Problems can result due to changes in temperature.

Before troubleshooting for low power or for poor performance in the winter, check the fuel for waxing

The following components can provide a means of minimizing fuel waxing problems in cold weather:

- Fuel heaters, which may be an OEM option
- Fuel line insulation, which may be an OEM option

Winter and arctic grades of diesel fuel are available in the countries and territories with severe winters. For more information refer to the Operation and Maintenance Manual, "Fuel For Cold-Weather Operation"

Another important fuel property which can affect cold start and operation of diesel engine is Cetane number. Detail and requirements of this property are given in this Operation and Maintenance Manual, "Fluid Recommendations".

For more information about fuel heaters (if equipped), refer to the OEM information.

i02323237

Fuel Related Components in Cold Weather

Fuel Tanks

Condensation can form in partially filled fuel tanks. Top off the fuel tanks after you operate the engine.

Fuel tanks should contain some provision for draining water and sediment from the bottom of the tanks.

Some fuel tanks use supply pipes that allow water and sediment to settle below the end of the fuel supply pipe.

Some fuel tanks use supply lines that take fuel directly from the bottom of the tank. If the engine is equipped with this system, regular maintenance of the fuel system filter is important.

Drain the water and sediment from any fuel storage tank at the following intervals: weekly, service intervals and refueling of the fuel tank. This will help prevent water and/or sediment from being pumped from the fuel storage tank and into the engine fuel tank.

Fuel Filters

A primary fuel filter is installed between the fuel tank and the engine fuel inlet. After you change the fuel filter, always prime the fuel system in order to remove air bubbles from the fuel system. Refer to the Operation and Maintenance Manual in the Maintenance Section for more information on priming the fuel system.

The location of a primary fuel filter is important in cold weather operation. The primary fuel filter and the fuel supply line are the most common components that are affected by cold fuel.

Fuel Heaters

Note: The OEM may equip the application with fuel heaters. If this is the case, the temperature of the fuel must not exceed 73 °C (163 °F) at the fuel transfer pump.

Engine Stopping

i05538749

Stopping the Engine

NOTICE

Stopping the engine immediately after it has been working under load, can result in overheating and accelerated wear of the engine components.

Avoid accelerating the engine prior to shutting it down.

Avoiding hot engine shutdowns will maximize turbo-charger shaft and bearing life.

Note: Individual applications will have different control systems. Ensure that the shutoff procedures are understood. Use the following general guidelines in order to stop the engine.

1. Remove the load from the engine. Reduce the engine speed to low idle. Allow the engine to idle for 5 minutes in order to cool the engine.
2. Stop the engine after the cool down period according to the shutoff system on the engine and turn the ignition keyswitch to the OFF position. If necessary, refer to the instructions that are provided by the OEM.
3. Allow 2 minutes after shutting down the engine before you turn the battery disconnect switch to OFF. The electric control module requires power in order to process information from the sensors before shutting down.

i03554860

Emergency Stopping

NOTICE

Emergency shutoff controls are for EMERGENCY use ONLY. DO NOT use emergency shutoff devices or controls for normal stopping procedure.

Ensure that any components for the external system that support the engine operation are secured after the engine is stopped.

Emergency Stop Button

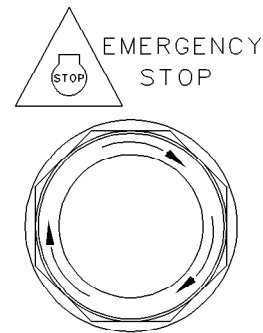

Illustration 33

g00104303

Typical emergency stop button

The emergency stop button is in the OUT position for normal engine operation. Push the emergency stop button. The engine will not start when the button is locked. Turn the button clockwise in order to reset.

Refer to Operation and Maintenance Manual, "Features and Controls" for the location and the operation of the emergency stop button.

i05298684

After Stopping Engine

Note: Before you check the engine oil, do not operate the engine for at least 10 minutes in order to allow the engine oil to return to the oil pan.

WARNING

Contact with high pressure fuel may cause fluid penetration and burn hazards. High pressure fuel spray may cause a fire hazard. Failure to follow these inspection, maintenance and service instructions may cause personal injury or death.

NOTICE

The low-pressure fuel system can be pressurized for a time period after the engine has stopped operating. The operating pressure of the low-pressure fuel system can be 500 kPa (73 psi). The secondary fuel filters should be drained before any maintenance of the low-pressure fuel system is carried out.

- After the engine has stopped, wait for 60 seconds in order to allow the fuel pressure to be purged from the high-pressure fuel lines before any service or repair is performed on the engine fuel lines. If necessary, perform minor adjustments. Repair any leaks from the low-pressure fuel system and from the cooling, lubrication, or air systems. Replace any high-pressure fuel line that has leaked. Refer to Disassembly and assembly Manual, “Fuel Injection Lines - Install”.
- Check the crankcase oil level. Maintain the oil level between the “MIN” mark and the “MAX” mark on the engine oil level gauge.
- If the engine is equipped with a service hour meter, note the reading. Perform the maintenance that is in the Operation and Maintenance Manual, “Maintenance Interval Schedule”.
- Fill the fuel tank, in order to help prevent accumulation of moisture in the fuel. Do not overfill the fuel tank.

NOTICE

Only use antifreeze/coolant mixtures recommended in this Operation and Maintenance Manual, “Refill Capacities and Recommendations” topic or in this Operation and Maintenance Manual, “Fluid Recommendations” topic. Failure to do so can cause engine damage.

 **WARNING**

Pressurized System: Hot coolant can cause serious burns. To open the cooling system filler cap, stop the engine and wait until the cooling system components are cool. Loosen the cooling system pressure cap slowly in order to relieve the pressure.

- Allow the engine to cool. Check the coolant level.
- Check the coolant for correct antifreeze protection and the correct corrosion protection. Add the correct coolant/water mixture, if necessary.
- Perform all required periodic maintenance on all driven equipment. This maintenance is outlined in the instructions from the OEM.

Maintenance Section

Refill Capacities

i05502490

Refill Capacities

Lubricating Oil

Table 6

Engine Refill Capacities		
Compartment or System	Minimum	Maximum
Crankcase Oil Sump ⁽¹⁾	5.7 L (1.5 US gal)	7 L (1.85 US gal)

⁽¹⁾ These values are the approximate capacities for the crankcase oil sump (flat steel) which includes the standard factory installed oil filters. Engines with auxiliary oil filters will require additional oil. Refer to the OEM specifications for the capacity of the auxiliary oil filter.

Coolant

Table 7

Engine Refill Capacities	
Compartment or System	Liters
Engine Only	7 L (1.85 US gal)
External System Per OEM ⁽¹⁾	

⁽¹⁾ The External System includes a radiator or an expansion tank with the following components: heat exchanger and piping. Refer to the OEM specifications. Enter the value for the capacity of the External System in this row.

Fuel

Refer to the original equipment manufactory for information on the capacity of the fuel tank.

i05253328

Fluid Recommendations (Fuel Specification)

- **Glossary**
- ISO International Standards Organization
- ASTM _____ American Society for Testing and Materials

- HFRR _____ High Frequency Reciprocating Rig for Lubricity testing of diesel fuels
- FAME _____ Fatty Acid Methyl Esters
- CFR _____ Co-ordinating Fuel Research
- RME _____ Rape Methyl Ester
- SME _____ Soy Methyl Ester
- EPA _____ Environmental Protection Agency of the United States
- PPM _____ Parts Per Million

General Information

NOTICE

Every attempt is made to provide accurate, up-to-date information. By use of this document you agree that Perkins Engines Company Limited is not responsible for errors or omissions.

NOTICE

These recommendations are subject to change without notice. Contact your local Perkins distributor for the most up-to-date recommendations.

Diesel Fuel Requirements

Perkins is not in a position to continuously evaluate and monitor all worldwide distillate diesel fuel specifications that are published by governments and technological societies.

The Perkins Specification for Distillate Diesel Fuel provides a known reliable baseline in order to judge the expected performance of distillate diesel fuels that are derived from conventional sources.

Satisfactory engine performance is dependent on the use of a good quality fuel. The use of a good quality fuel will give the following results: long engine life and acceptable exhaust emissions levels. The fuel must meet the minimum requirements that are stated in the table 8 .

NOTICE

The footnotes are of the key part Perkins Specification for Distillate Diesel Fuel Table. Read ALL of the footnotes.

Table 8

Perkins Specification for Distillate Diesel Fuel ⁽¹⁾				
Property	UNITS	Requirements	"ASTM"Test	"ISO"Test
Aromatics	%Volume	35% maximum	D1319	"ISO"3837
Ash	%Weight	0.01% maximum	D482	"ISO"6245
Carbon Residue on 10% Bottoms	%Weight	0.35% maximum	D524	"ISO"4262
Cetane Number ⁽²⁾	-	40 minimum	D613/D6890	"ISO"5165
Cloud Point	°C	The cloud point must not exceed the lowest expected ambient temperature.	D2500	"ISO"3015
Copper Strip Corrosion	-	No. 3 maximum	D130	"ISO"2160
Density at 15 °C (59 °F) ⁽³⁾	Kg / M ³	801 minimum and 876 maximum	No equivalent test	"ISO 3675" "ISO 12185"
Distillation	°C	10% at 282 °C (539.6 °F) maximum	D86	"ISO"3405
		90% at 360 °C (680 °F) maximum		
Flash Point	°C	legal limit	D93	"ISO"2719
Thermal Stability	-	Minimum of 80% reflectance after aging for 180 minutes at 150 °C (302 °F)	D6468	No equivalent test
Pour Point	°C	6 °C (42.8 °F) minimum below ambient temperature	D97	"ISO"3016
Sulfur ⁽¹⁾	%mass	Legal limit or up to 1% maximum in unregulated regions.	D5453 or D26222	"ISO 20846" or "ISO 20884"
Kinematic Viscosity ⁽⁴⁾	"MM" ² /S (cSt)"	The viscosity of the fuel that is delivered to the fuel injection pump. "1.4 minimum/ 4.5 maximum"	D445	"ISO"3405
Water and sediment	%(VV)	0.05% maximum	D1796	"ISO"3734
Water	%	0.05% maximum	D1744	No equivalent test
Sediment	%	0.05% maximum	D473	"ISO"3735
Gums and Resins ⁽⁵⁾	mg/100mL	10 mg per 100 mL maximum	D381	"ISO"6246
Lubricity corrected wear scar diameter at 60 °C (140 °F). ⁽⁶⁾	mm	0.52 maximum	D6079	"ISO"12156-1

⁽¹⁾ Regional regulations, national regulations, or international regulations can require a fuel with a specific sulfur limit. Consult all applicable regulations before selecting a fuel for a given engine application. Perkins fuel systems and engine components can operate on high sulphur fuels. Fuel sulfur levels affect exhaust emissions. High sulfur fuels also increase the potential for corrosion of internal components. Fuel sulfur levels above 0.05% may significantly shorten the oil change interval. For additional information, refer to this manual, Sulfur section, and service interval with high sulphur fuel.

⁽²⁾ A minimum 45 cetane number is recommended for operations in cold weather below 0° C (32° F) ambient and high altitude.

⁽³⁾ "Via standards tables, the equivalent API gravity for the minimum density of 801 kg / m³ (kilograms per cubic meter) is 45 and for the maximum density of 876 kg / m³ is 30".

(continued)

Maintenance Section

Fuel Specification

(Table 8, contd)

- (4) The values of the fuel viscosity are the values as the fuel is delivered to the fuel injection pumps. Fuel should also meet the minimum viscosity requirement and the fuel should meet the maximum viscosity requirements at 40°C (104°F) of either the “ASTM D445” test method or the “ISO 3104” test method. If a fuel with a low viscosity is used, cooling of the fuel may be required to maintain “1.4 cSt” or greater viscosity at the fuel injection pump. Fuels with a high viscosity might require fuel heaters in order to lower the viscosity to “1.4 cSt” at the fuel injection pump.
- (5) Follow the test conditions and procedures for gasoline (motor).
- (6) Refer to the lubricity section within this Fuel Recommendation Section.

Engines that are manufactured by Perkins are certified with the fuel that is prescribed by the appropriate regulatory agency. Engines that are manufactured by Perkins are certified with the fuel that is prescribed by the European Certification. Perkins does not certify diesel engines on any other fuel.

Note: The owner and the operator of the engine has responsibility of using the fuel that is prescribed by the EPA and other appropriate regulatory agencies.

NOTICE

Operating with fuels that do not meet the Perkins recommendations can cause the following effects: Starting difficulty, reduced fuel filter service life, poor combustion, deposits in the fuel injectors, significantly reduce service life of the fuel system, deposits in the combustion chamber and reduced service life of the engine.

Diesel Fuel Characteristics

Cetane Number

Fuel that has a high cetane number will give a shorter ignition delay. A high cetane number will produce a better ignition quality. Cetane numbers are derived for fuels against proportions of cetane and heptamethylnonane in the standard CFR engine. Refer to “ISO 5165” for the test method.

Cetane numbers in excess of 45 are normally expected from current diesel fuel. However, a cetane number of 40 may be experienced in some territories. The United States of America is one of the territories that can have a low cetane value. A minimum cetane value of 40 is required during average starting conditions. A fuel with higher cetane number is recommended for operations at high altitudes or in cold-weather operations.

Fuel with a low cetane number can be the root cause of problems during a cold start.

Viscosity

Viscosity is the property of a liquid of offering resistance to shear or flow. Viscosity decreases with increasing temperature. This decrease in viscosity follows a logarithmic relationship for normal fossil fuel. The common reference is to kinematic viscosity. Kinematic viscosity is the quotient of the dynamic viscosity that is divided by the density. The determination of kinematic viscosity is normally by readings from gravity flow viscometers at standard temperatures. Refer to “ISO 3104” for the test method.

The viscosity of the fuel is significant because fuel serves as a lubricant for the fuel system components. Fuel must have sufficient viscosity in order to lubricate the fuel system in both extremely cold temperatures and extremely hot temperatures. If the kinematic viscosity of the fuel is lower than “1.4 cSt” at the fuel injection pump, damage to the fuel injection pump can occur. This damage can be excessive scuffing and seizure. Low viscosity may lead to difficult hot restarting, stalling, and loss of performance. High viscosity may result in seizure of the pump.

Perkins recommends kinematic viscosities of 1.4 and 4.5 mm²/sec that is delivered to the fuel injection pump. If a fuel with a low viscosity is used, cooling of the fuel may be required to maintain 1.4 cSt or greater viscosity at the fuel injection pump. Fuels with a high viscosity might require fuel heaters in order to lower the viscosity to 4.5 cSt at the fuel injection pump.

Density

Density is the mass of the fuel per unit volume at a specific temperature. This parameter has a direct influence on engine performance and a direct influence on emissions. This influence determines from a heat output given injected volume of fuel. This parameter is quoted in the following kg/m³ at 15 °C (59 °F).

Perkins recommends a density of 841 kg/m³ in order to obtain the correct power output. Lighter fuels are acceptable but these fuels will not produce the rated power.

Sulfur

The level of sulfur is governed by emissions legislations. Regional regulation, national regulations, or international regulations can require a fuel with a specific sulfur limit. The sulfur content of the fuel and the fuel quality must comply with all existing local regulations for emissions.

Lubricity

Lubricity is the capability of the fuel to prevent pump wear. The fluids lubricity describes the ability of the fluid to reduce the friction between surfaces that are under load. This ability reduces the damage that is caused by friction. Fuel injection systems rely on the lubricating properties of the fuel. Until fuel sulfur limits were mandated, the fuels lubricity was generally believed to be a function of fuel viscosity.

The lubricity has particular significance to the current low sulfur fuel, and low aromatic fossil fuels. These fuels are made in order to meet stringent exhaust emissions.

The lubricity of these fuels must not exceed wear scar diameter of 0.52 mm (0.0205 inch). The fuel lubricity test must be performed on an HFRR, operated at 60 °C (140 °F). Refer to "ISO 12156-1".

NOTICE

The fuels system has been qualified with fuel having lubricity up to 0.52 mm (0.0205 inch) wear scar diameter as tested by "ISO 12156-1". Fuel with higher wear scar diameter than 0.52 mm (0.0205 inch) will lead to reduced service life and premature failure of the fuel system.

Fuel additives can enhance the lubricity of a fuel. Contact your fuel supplier for those circumstances when fuel additives are required. Your fuel supplier can make recommendations for additives to use, and for the proper level of treatment.

Distillation

Distillation is an indication of the mixture of different hydrocarbons in the fuel. A high ratio of light weight hydrocarbons can affect the characteristics of combustion.

Classification of the Fuels

Diesel engines have the ability to burn wide variety of fuels. The following list of typically encountered fuel specifications that have been assessed as to their acceptability and are divided into following categories:

Group 1: Preferred fuels

Following fuel specifications are considered acceptable

- Fuels meeting the requirements of the "Perkins Specification for Distillate Diesel Fuel" listed in the Table 8 .
- EN590 - Grades A to F and class 0 to 4
- ASTM D975 Grade No. 1-D and 2-D
- JIS K2204 Grades 1, 2 & 3 & Special Grade 3 acceptable provides lubricity wear diameter does not exceed of 0.46 mm (0.01811 inch) "ISO 12156-1"
- BS2869-Class A2 Off Highway Gas Oil, Red Diesel

Note: The lubricity of these fuels must not exceed wear scar diameter of 0.52 mm (0.02047 inch) as per "ISO 12156-1". Refer to the lubricity section within the Fuel Recommendation Section.

Group 3 Biodiesel Fuel

Recommendation for Biodiesel

Biodiesel is a fuel that can be defined as mono-alkyl esters of fatty acids. Biodiesel is a fuel that can be made from various feedstock. The most commonly available biodiesel in Europe is Rape Methyl Ester (RME). This biodiesel is derived from rapeseed oil. Soy Methyl Ester (SME) is the most common biodiesel in the United States. This biodiesel is derived from soybean oil. Soybean oil or rapeseed oil are the primary feedstocks. These fuels are together known as Fatty Acid Methyl Esters (FAME).

Raw pressed vegetable oils are NOT acceptable for use as a fuel in any concentration in compression engines. Without esterification, these oils solidify in the crankcase and the fuel tank. These fuels may not be compatible with many of the elastomers that are used in engines that are manufactured today. In original forms, these oils are not suitable for use as a fuel in compression engines. Alternate base stocks for biodiesel may include animal tallow, waste cooking oils, or various other feedstocks. In order to use any of the products that are listed as fuel, the oil must be esterified.

Fuel made of 100 percent FAME is generally referred to as B100 biodiesel or neat biodiesel.

Biodiesel can be blended with distillate diesel fuel. The blends can be used as fuel. The most commonly available biodiesel blends are B7, which is 7 percent biodiesel and 95 percent distillate diesel fuel. B20, which is 20 percent biodiesel and 80 percent distillate diesel fuel.

Note: The percentages given are volume-based.

The U.S. distillate diesel fuel specification "ASTM D975-09a" includes up to B7 (7 percent) biodiesel.

European distillate diesel fuel specification EN590: 2010 includes up B7 (7 percent) biodiesel.

Note: Engines that are manufactured by Perkins are certified by use of the prescribed Environmental Protection Agency (EPA) and European Certification Agency (EPA) and European Certification Agency (EPA) and European Certification Agency (EPA) fuels. Perkins does not certify engines on any other fuel. The user of the engine has the responsibility of using the correct fuel that is recommended by the manufacturer and allowed by the EPA and other appropriate regulatory agencies.

Specification Requirements

The neat biodiesel must conform to the latest "EN14214 or ASTM D6751" (in the USA). The biodiesel can only be blended in mixture of up to 20% by volume in acceptable mineral diesel fuel meeting latest edition of "EN590 or ASTM D975 S15" designation.

In United States Biodiesel blends of B6 to B20 must meet the requirements listed in the latest edition of "ASTM D7467" (B6 to B20) and must be of an API gravity of 30-45.

In North America biodiesel and biodiesel blends must be purchased from the BQ-9000 accredited producers and BQ-9000 certified distributors.

In other areas of the world, the use of biodiesel that is BQ-9000 accredited and certified, or that is accredited and certified by a comparable biodiesel quality body to meet similar biodiesel quality standards is required.

Engine Service Requirements

Aggressive properties of biodiesel fuel may cause debris in the fuel tank and fuel lines. The aggressive properties of biodiesel will clean the fuel tank and fuel lines. This cleaning of the fuel system can prematurely block of the fuel filters. Perkins recommend that after the initial usage of B20 biodiesel blended fuel the fuel filters must be replaced at 50 hours.

Glycerides present in biodiesel fuel will also cause fuel filters to become blocked more quickly. Therefore the regular service interval should be reduced to 250 hours.

When biodiesel fuel is used, crank case oil and aftertreatment systems may be influenced. This influence is due to the chemical composition and characteristics of biodiesel fuel, such as density and volatility, and to chemical contaminants that can be present in this fuel, such as alkali and alkaline metals (sodium, potassium, calcium, and magnesium).

- Crankcase oil fuel dilution can be higher when biodiesel or biodiesel blends are used. This increased level of fuel dilution when using biodiesel or biodiesel blends is related to the typically lower volatility of biodiesel. In-cylinder emissions control strategies utilized in many of the industrial latest engine designs may lead to a higher level of biodiesel concentration in the sump. The long-term effect of biodiesel concentration in crankcase oil is currently unknown.
- Perkins recommend the use of oil analysis in order to check the quality of the engine oil if biodiesel fuel is used. Ensure that the level of biodiesel in the fuel is noted when the oil sample is taken.

Performance Related Issues

Due to the lower energy content than the standard distillate fuel B20 will cause a power loss in order of 2 to 4 percent. In addition, over time the power may deteriorate further due to deposits in the fuel injectors.

Biodiesel and biodiesel blends are known to cause an increase in fuel system deposits, most significant of which are deposits within the fuel injector. These deposits can cause a loss in power due to restricted or modified fuel injection or cause other functional issues associated with these deposits.

Note: Perkins T400012 Fuel Cleaner is most effective in cleaning and preventing the formation of deposits. Perkins Diesel Fuel Conditioner helps to limit deposit issues by improving the stability of biodiesel and biodiesel blends. For more information refer to "Perkins Diesel Fuel System Cleaner, and Perkins".

Biodiesel fuel contains metal contaminants (sodium, potassium, calcium, and/or magnesium) that form ash products upon combustion in the diesel engine. The ash can have an impact on the life and performance of aftertreatment emissions control devices and can accumulate in DPF. The ash accumulation may cause the need for more frequent ash service intervals and cause loss of performance

General Requirements

Biodiesel has poor oxidation stability, which can result in long-term problems in the storage of biodiesel. Biodiesel fuel should be used within 6 months of manufacture. Equipment should not be stored with the B20 biodiesel blends in the fuel system for longer than 3 months.

Due to poor oxidation stability and other potential issues, it is strongly recommended that engines with limited operational time either not use B20 biodiesel blends or, while accepting some risk, limit biodiesel blend to a maximum of B5. Examples of applications that should limit the use of biodiesel are the following: Standby Generator sets and certain emergency vehicles.

Perkins strongly recommended that seasonally operated engines have the fuel systems, including fuel tanks, flashed with conventional diesel fuel before prolonged shutdown periods. An example of an application that should seasonally flush the fuel system is a combine harvester.

Microbial contamination and growth can cause corrosion in the fuel system and premature plugging of the fuel filter. Consult your supplier of fuel for assistance in selecting appropriate anti-microbial additive.

Water accelerates microbial contamination and growth. When biodiesel is compared to distillate fuels, water is naturally more likely to exist in the biodiesel. It is therefore essential to check frequently and if necessary, drain the water separator.

Materials such as brass, bronze, copper, lead, tin, and zinc accelerate the oxidation process of the biodiesel fuel. The oxidation process can cause deposits formation therefore these materials must not be used for fuel tanks and fuel lines.

Fuel for Cold Weather Operation

The European standard "EN590" contains climate dependant requirements and a range of options. The options can be applied differently in each country. There are five classes that are given to arctic climates and severe winter climates. 0, 1, 2, 3 and 4.

Fuel that complies with "EN590" CLASS 4 can be used at temperatures as low as $-44\text{ }^{\circ}\text{C}$ ($-47.2\text{ }^{\circ}\text{F}$). Refer to "EN590" for a detailed discretion of the physical properties of the fuel.

The diesel fuel "ASTM D975 1-D" used in the United States of America may be used in very cold temperatures that are below $-18\text{ }^{\circ}\text{C}$ ($-0.4\text{ }^{\circ}\text{F}$).

Aftermarket Fuel Additives

Supplemental diesel fuel additives are not generally recommended. This recommendation is due to potential damage to the fuel system or the engine. Your fuel supplier or the fuel manufacturer will add the appropriate supplemental diesel fuel additives.

Perkins recognizes the fact that additives may be required in some special circumstances. Contact your fuel supplier for those circumstances when fuel additives are required. Your fuel supplier can recommend the appropriate fuel additive and the correct level of treatment.

Note: For the best results, your fuel supplier should treat the fuel when additives are required. The treated fuel must meet the requirements that are stated in table 8 .

Perkins Diesel Fuel System Cleaner

Perkins T400012 Fuel Cleaner is the only fuel cleaner that is recommended by Perkins.

If biodiesel or biodiesel blends of fuel are to be used, Perkins require the use of Perkins fuel cleaner. The use of the fuel is in order to remove deposits within the fuel system that is created with the use of biodiesel. For more information on the use of biodiesel and biodiesel blends refer to "Group 3 Biodiesel Fuel".

Perkins fuel cleaner will remove deposits that can form in the fuel system with the use of biodiesel and biodiesel blends. These deposits can create a loss of power and engine performance.

Once the fuel cleaner has been added to the fuel, the deposits within the fuel system are removed after 30 hours of engine operation. For maximum results, continue to use the fuel cleaner for up to 80 hours. Perkins fuel cleaner can be used on an on-going basis with no adverse impact on engine or fuel system durability.

Details instruction on the rate of which the fuel cleaner must be use are on the container.

Note: Perkins fuel cleaner is compatible with existing and U.S. EPA Tier 3 nonroad certified diesel engine emission control catalysts and particulate filters. Perkins fuel system cleaner contains less than 15 ppm of sulfur and is acceptable for use with LSD fuel.

Service Intervals for Biodiesel and High sulfur Fuels.

Table 9

B20 Biodiesel Engine Service
First 50 hours fuel filter change
Every 250 hours fuel filter change
Required T400012 Fuel Cleaner

Table 10

Fuel Sulfur Content greater than 500 PPM
Every 250 hours oil and oil filter change

i05271102

Fluid Recommendations

General Coolant Information

NOTICE

Never add coolant to an overheated engine. Engine damage could result. Allow the engine to cool first.

NOTICE

If the engine is to be stored in, or shipped to an area with below freezing temperatures, the cooling system must be either protected to the lowest outside temperature or drained completely to prevent damage.

NOTICE

Frequently check the specific gravity of the coolant for proper freeze protection or for anti-boil protection.

Clean the cooling system for the following reasons:

- Contamination of the cooling system
- Overheating of the engine
- Foaming of the coolant

NOTICE

Never operate an engine without water temperature regulators in the cooling system. Water temperature regulators help to maintain the engine coolant at the proper operating temperature. Cooling system problems can develop without water temperature regulators.

Many engine failures are related to the cooling system. The following problems are related to cooling system failures: Overheating, leakage of the water pump and plugged radiators or heat exchangers.

These failures can be avoided with correct cooling system maintenance. Cooling system maintenance is as important as maintenance of the fuel system and the lubrication system. Quality of the coolant is as important as the quality of the fuel and the lubricating oil.

Coolant is normally composed of three elements: Water, additives and glycol.

Water

Water is used in the cooling system in order to transfer heat.

Distilled water or deionized water is recommended for use in engine cooling systems.

DO NOT use the following types of water in cooling systems: Hard water, softened water that has been conditioned with salt and sea water.

If distilled water or deionized water is not available, use water with the properties that are listed in Table 11 .

Table 11

Acceptable Water	
Property	Maximum Limit
Chloride (Cl)	40 mg/L
Sulfate (SO ₄)	100 mg/L
Total Hardness	170 mg/L
Total Solids	340 mg/L
Acidity	pH of 5.5 to 9.0

For a water analysis, consult one of the following sources:

- Local water utility company
- Agricultural agent
- Independent laboratory

Additives

Additives help to protect the metal surfaces of the cooling system. A lack of coolant additives or insufficient amounts of additives enable the following conditions to occur:

- Corrosion
- Formation of mineral deposits
- Rust
- Scale
- Foaming of the coolant

Many additives are depleted during engine operation. These additives must be replaced periodically.

Additives must be added at the correct concentration. Over concentration of additives can cause the inhibitors to drop out-of-solution. The deposits can enable the following problems to occur:

- Formation of gel compounds

- Reduction of heat transfer
- Leakage of the water pump seal
- Plugging of radiators, coolers, and small passages

Glycol

Glycol in the coolant helps to provide protection against the following conditions:

- Boiling
- Freezing
- Cavitation of the water pump

For optimum performance, Perkins recommends a 1:1 mixture of a water/glycol solution.

Note: Use a mixture that will provide protection against the lowest ambient temperature.

Note: 100 percent pure glycol will freeze at a temperature of -13 °C (8.6 °F).

Most conventional antifreezes use ethylene glycol. Propylene glycol may also be used. In a 1:1 mixture with water, ethylene and propylene glycol provide similar protection against freezing and boiling. Refer to Table 12 and refer to table 13 .

Table 12

Ethylene Glycol	
Concentration	Freeze Protection
50 Percent	-36 °C (-33 °F)
60 Percent	-51 °C (-60 °F)

NOTICE

Do not use propylene glycol in concentrations that exceed 50 percent glycol because of the reduced heat transfer capability of propylene glycol. Use ethylene glycol in conditions that require additional protection against boiling or freezing.

Table 13

Propylene Glycol	
Concentration	Freeze Protection
50 Percent	-29 °C (-20 °F)

To check the concentration of glycol in the coolant, measure the specific gravity of the coolant.

Coolant Recommendations

- ELC_____Extended Life Coolant
- SCA_____Supplement Coolant Additive

- ASTM_____American Society for Testing and Materials

The following two coolants are used in Perkins diesel engines:

Preferred – Perkins ELC

Acceptable – A commercial heavy-duty antifreeze that meets “ASTM D6210 ” specifications

NOTICE

The 1200 series industrial engines must be operated with a 1:1 mixture of water and glycol. This concentration allows the NOx reduction system to operate correctly at high ambient temperatures.

NOTICE

Do not use a commercial coolant/antifreeze that only meets the ASTM D3306 specification. This type of coolant/antifreeze is made for light automotive applications.

Perkins recommends a 1:1 mixture of water and glycol. This mixture of water and glycol will provide optimum heavy-duty performance as an antifreeze. This ratio may be increased to 1:2 water to glycol if extra freezing protection is required.

A mixture of SCA inhibitor and water is acceptable but will not give the same level of corrosion, boiling and, freezing protection as ELC. Perkins recommends a 6 percent to 8 percent concentration of SCA in those cooling systems. Distilled water or deionized water is preferred. Water which has the recommended properties may be used.

Table 14

Coolant Service Life	
Coolant Type	Service Life ⁽¹⁾
Perkins ELC	6,000 Service Hours or Three Years
Commercial Heavy-Duty Antifreeze that meets “ASTM D6210”	3000 Service Hours or Two Year
Commercial SCA inhibitor and Water	3000 Service Hours or One Year

⁽¹⁾ Use the interval that occurs first. The cooling system must also be flushed out at this time.

ELC

Perkins provides ELC for use in the following applications:

- Heavy-duty spark ignited gas engines
- Heavy-duty diesel engines

- Automotive applications

The anti-corrosion package for ELC is different from the anti-corrosion package for other coolants. ELC is an ethylene glycol base coolant. However, ELC contains organic corrosion inhibitors and antifoam agents with low amounts of nitrite. Perkins ELC has been formulated with the correct amount of these additives in order to provide superior corrosion protection for all metals in engine cooling systems.

ELC is available in a premixed cooling solution with distilled water. ELC is a 1:1 mixture. The Premixed ELC provides freeze protection to -36°C (-33°F). The Premixed ELC is recommended for the initial fill of the cooling system. The Premixed ELC is also recommended for topping off the cooling system.

Containers of several sizes are available. Consult your Perkins distributor for the part numbers.

ELC Cooling System Maintenance

Correct additions to the Extended Life Coolant

NOTICE

Use only Perkins products for pre-mixed or concentrated coolants.

Mixing Extended Life Coolant with other products reduces the Extended Life Coolant service life. Failure to follow the recommendations can reduce cooling system components life unless appropriate corrective action is performed.

In order to maintain the correct balance between the antifreeze and the additives, you must maintain the recommended concentration of ELC. Lowering the proportion of antifreeze lowers the proportion of additive. This will lower the ability of the coolant to protect the system from pitting, from cavitation, from erosion, and from deposits.

NOTICE

Do not use a conventional coolant to top-off a cooling system that is filled with Extended Life Coolant (ELC).

Do not use standard supplemental coolant additive (SCA).

When using Perkins ELC, do not use standard SCA's or SCA filters.

ELC Cooling System Cleaning

Note: If the cooling system is already using ELC, cleaning agents are not required to be used at the specified coolant change interval. Cleaning agents are only required if the system has been contaminated by the addition of some other type of coolant or by cooling system damage.

Clean water is the only cleaning agent that is required when ELC is drained from the cooling system.

Before the cooling system is filled, the heater control (if equipped) must be set to the HOT position. Refer to the OEM in order to set the heater control. After the cooling system is drained and the cooling system is refilled, operate the engine until the coolant level reaches the normal operating temperature and until the coolant level stabilizes. As needed, add the coolant mixture in order to fill the system to the specified level.

Changing to Perkins ELC

To change from heavy-duty antifreeze to the Perkins ELC, perform the following steps:

NOTICE

Care must be taken to ensure that all fluids are contained during performance of inspection, maintenance, testing, adjusting and the repair of the product. Be prepared to collect the fluid with suitable containers before opening any compartment or disassembling any component containing fluids.

Dispose of all fluids according to local regulations and mandates.

1. Drain the coolant into a suitable container.
2. Dispose of the coolant according to local regulations.
3. Flush the system with clean water in order to remove any debris.
4. Use an appropriate cleaner to clean the system. Follow the instruction on the label.
5. Drain the cleaner into a suitable container. Flush the cooling system with clean water.
6. Fill the cooling system with clean water and operate the engine until the engine is warmed to 49° to 66°C (120° to 150°F).

NOTICE

Incorrect or incomplete flushing of the cooling system can result in damage to copper and other metal components.

To avoid damage to the cooling system, make sure to completely flush the cooling system with clear water. Continue to flush the system until all the signs of the cleaning agent are gone.

7. Drain the cooling system into a suitable container and flush the cooling system with clean water.

Note: The cooling system cleaner must be thoroughly flushed from the cooling system. Cooling system cleaner that is left in the system will contaminate the coolant. The cleaner may also corrode the cooling system.

8. Repeat Steps 6 and repeat steps 7 until the system is completely clean.
9. Fill the cooling system with the Perkins Premixed ELC.

ELC Cooling System Contamination

NOTICE

Mixing ELC with other products reduces the effectiveness of the ELC and shortens the ELC service life. Use only Perkins Products for premixed or concentrate coolants. Failure to follow these recommendations can result in shortened cooling system component life.

ELC cooling systems can withstand contamination to a maximum of 10 percent of conventional heavy-duty antifreeze or SCA. If the contamination exceeds 10 percent of the total system capacity, perform ONE of the following procedures:

- Drain the cooling system into a suitable container. Dispose of the coolant according to local regulations. Flush the system with clean water. Fill the system with the Perkins ELC.
- Drain a portion of the cooling system into a suitable container according to local regulations. Then, fill the cooling system with premixed ELC. This procedure should lower the contamination to less than 10 percent.
- Maintain the system as a conventional Heavy-Duty Coolant. Treat the system with an SCA. Change the coolant at the interval that is recommended for the conventional Heavy-Duty Coolant.

Commercial Heavy-Duty Antifreeze and SCA

NOTICE

Commercial Heavy-Duty Coolant which contains Amine as part of the corrosion protection system must not be used.

NOTICE

Never operate an engine without water temperature regulators in the cooling system. Water temperature regulators help to maintain the engine coolant at the correct operating temperature. Cooling system problems can develop without water temperature regulators.

Check the antifreeze (glycol concentration) in order to ensure adequate protection against boiling or freezing. Perkins recommends the use of a refractometer for checking the glycol concentration. A hydrometer should not be used.

Perkins engine cooling systems should be tested at 500 hour intervals for the concentration of SCA.

Additions of SCA are based on the results of the test. An SCA that is liquid may be needed at 500 hour intervals.

Adding the SCA to Heavy-Duty Coolant at the Initial Fill

Use the equation that is in Table 15 to determine the amount of SCA that is required when the cooling system is initially filled.

Table 15

Equation For Adding The SCA To The Heavy-Duty Coolant At The Initial Fill
$V \times 0.045 = X$
V is the total volume of the cooling system.
X is the amount of SCA that is required.

Table 16 is an example for using the equation that is in Table 15 .

Table 16

Example Of The Equation For Adding The SCA To The Heavy-Duty Coolant At The Initial Fill		
Total Volume of the Cooling System (V)	Multiplication Factor	Amount of SCA that is Required (X)
15 L (4 US gal)	× 0.045	0.7 L (24 oz)

Adding The SCA to The Heavy-Duty Coolant For Maintenance

Heavy-duty antifreeze of all types REQUIRE periodic additions of an SCA.

Test the antifreeze periodically for the concentration of SCA. For the interval, refer to the Operation and Maintenance Manual, "Maintenance Interval Schedule" (Maintenance Section). Cooling System Supplemental Coolant Additive (SCA) Test/Add.

Additions of SCA are based on the results of the test. The size of the cooling system determines the amount of SCA that is needed.

Use the equation that is in Table 17 to determine the amount of SCA that is required, if necessary:

Table 17

Equation For Adding The SCA To The Heavy-Duty Coolant For Maintenance
$V \times 0.014 = X$
V is the total volume of the cooling system.
X is the amount of SCA that is required.

Table 18 is an example for using the equation that is in Table 17 .

Table 18

Example Of The Equation For Adding The SCA To The Heavy-Duty Coolant For Maintenance		
Total Volume of the Cooling System (V)	Multiplication Factor	Amount of SCA that is Required (X)
15 L (4 US gal)	$\times 0.014$	0.2 L (7 oz)

Cleaning the System of Heavy-Duty Antifreeze

- Clean the cooling system after used coolant is drained or before the cooling system is filled with new coolant.
- Clean the cooling system whenever the coolant is contaminated or whenever the coolant is foaming.

i05636197

Fluid Recommendations (Engine Oil Specification)

General Lubricant Information

Because of government regulations regarding the certification of exhaust emissions from the engine, the lubricant recommendations must be followed.

- API _____ American Petroleum Institute
- SAE _____ Society Of Automotive Engineers Inc.
- ECF _____ Engine Crankcase Fluid

Licensing

The Engine Oil Licensing and Certification System by the American Petroleum Institute (API) is recognized by Perkins. For detailed information about this system, see the latest edition of the "API publication No. 1509". Engine oils that bear the API symbol are authorized by API.

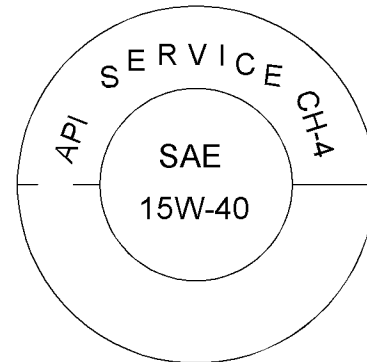

Illustration 34

g03580218

Typical API symbol

Terminology

Certain abbreviations follow the nomenclature of "SAE J754". Some classifications follow "SAE J183" abbreviations, and some classifications follow the "EMA Recommended Guideline on Diesel Engine Oil". In addition to Perkins definitions, there are other definitions that will be of assistance in purchasing lubricants. Recommended oil viscosities can be found in this publication, "Fluid Recommendations/Engine Oil Specification" topic (Maintenance Section).

Engine Oil

Commercial Oils

NOTICE

Perkins require the use of the following specification of engine oil. Failure to use the appropriate specification of engine oil will reduce the life of your engine.

Table 19

Minimum Oil Specification for 1104D-E44T and 1104D-E44TA Industrial Engines	
Minimum Oil specification	API CH-4 ECF 1

Engines Operating on B20 Biodiesel

Refer to this Manual Fluid Recommendations, "Fuel Specification" for the required service interval for operating with B20.

Engines Operating on High Sulfur Fuel

Refer to this Manual Fluid Recommendations, "Fuel Specification" for the required service interval for operating with high sulfur fuel.

Lubricant Viscosity Recommendations for Direct Injection (DI) Diesel Engines

The correct SAE viscosity grade of oil is determined by the minimum ambient temperature during cold engine start-up, and the maximum ambient temperature during engine operation.

Refer to illustration 35 (minimum temperature) in order to determine the required oil viscosity for starting a cold engine.

Refer to illustration 35 (maximum temperature) in order to select the oil viscosity for engine operation at the highest ambient temperature that is anticipated.

Generally, use the highest oil viscosity that is available to meet the requirement for the temperature at start-up.

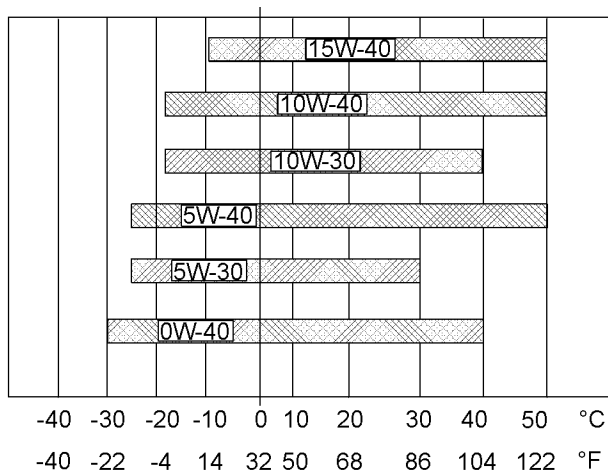

Illustration 35

g03347115

Lubricant Viscosities

Supplemental heat is recommended for cold soaked starts below the minimum ambient temperature. Supplemental heat may be required for cold soaked starts that are above the minimum temperature that is stated, depending on the parasitic load and other factors. Cold soaked starts occur when the engine has not been operated for a period of time. This interval will allow the oil to become more viscous due to cooler ambient temperatures.

Aftermarket Oil Additives

Perkins does not recommend the use of aftermarket additives in oil. It is not necessary to use aftermarket additives in order to achieve the engines maximum service life or rated performance. Fully formulated, finished oils consist of base oils and of commercial additive packages. These additive packages are blended into the base oils at precise percentages in order to help provide finished oils with performance characteristics that meet industry standards.

There are no industry standard tests that evaluate the performance or the compatibility of aftermarket additives in finished oil. Aftermarket additives may not be compatible with the finished oils additive package, which could lower the performance of the finished oil. The aftermarket additive could fail to mix with the finished oil. This failure could produce sludge in the crankcase. Perkins discourages the use of aftermarket additives in finished oils.

To achieve the best performance from a Perkins engine, conform to the following guidelines:

- See the appropriate "Lubricant Viscosities". Refer to the illustration 35 in order to find the correct oil viscosity grade for your engine.
- At the specified interval, service the engine. Use new oil and install a new oil filter.
- Perform maintenance at the intervals that are specified in the Operation and Maintenance Manual, "Maintenance Interval Schedule or Fluid Recommendations Fuel Specification".

Oil analysis

Some engines may be equipped with an oil sampling valve. If oil analysis is required, the oil sampling valve is used to obtain samples of the engine oil. The oil analysis will complement the preventive maintenance program.

The oil analysis is a diagnostic tool that is used to determine oil performance and component wear rates. Contamination can be identified and measured by using oil analysis. The oil analysis includes the following tests:

- The Wear Rate Analysis monitors the wear of the engines metals. The amount of wear metal and type of wear metal that is in the oil is analyzed. The increase in the rate of engine wear metal in the oil is as important as the quantity of engine wear metal in the oil.
- Tests are conducted in order to detect contamination of the oil by water, glycol, or fuel.

- The Oil Condition Analysis determines the loss of the oils lubricating properties. An infrared analysis is used to compare the properties of new oil to the properties of the used oil sample. This analysis allows technicians to determine the amount of deterioration of the oil during use. This analysis also allows technicians to verify the performance of the oil according to the specification during the entire oil change interval.

Maintenance Recommendations

i05539006

Welding on Engines with Electronic Controls

NOTICE

Because the strength of the frame may decrease, some manufacturers do not recommend welding onto a chassis frame or rail. Consult the OEM of the equipment or your Perkins dealer regarding welding on a chassis frame or rail.

Proper welding procedures are necessary in order to avoid damage to the engines ECM, sensors, and associated components. When possible, remove the component from the unit and then weld the component. If removal of the component is not possible, the following procedure must be followed when you weld on a unit equipped with an Electronic Engine. The following procedure is considered to be the safest procedure to weld on a component. This procedure should provide a minimum risk of damage to electronic components.

NOTICE

Do not ground the welder to electrical components such as the ECM or sensors. Improper grounding can cause damage to the drive train bearings, hydraulic components, electrical components, and other components.

Clamp the ground cable from the welder to the component that will be welded. Place the clamp as close as possible to the weld. This will help reduce the possibility of damage.

Note: Perform the welding in areas that are free from explosive hazards.

1. Stop the engine. Turn the switched power to the OFF position.
2. Ensure that the fuel supply to the engine is turned off.
3. Disconnect the negative battery cable from the battery. If a battery disconnect switch is provided, open the switch.
4. Disconnect all electronic components from the wiring harnesses. Include the following components:
 - Electronic components for the driven equipment

- ECM
- Sensors
- Electric operated fuel pump
- Electronically controlled valves
- Relays

NOTICE

Do not use electrical components (ECM or ECM sensors) or electronic component grounding points for grounding the welder.

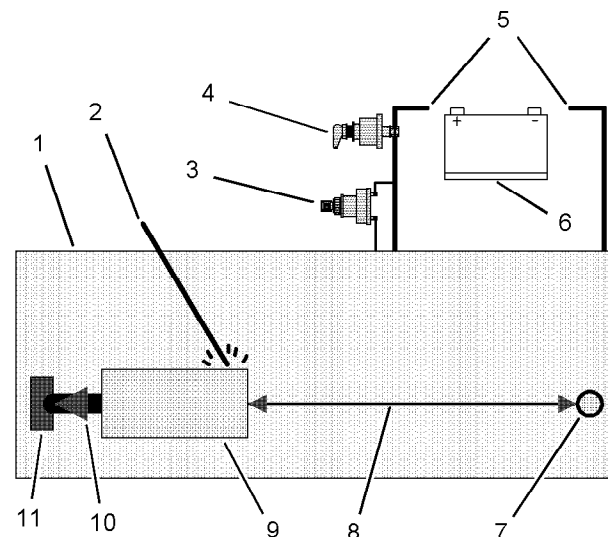

Illustration 36

g01075639

Use the example above. The current flow from the welder to the ground clamp of the welder will not damage any associated components.

- (1) Engine
- (2) Welding electrode
- (3) Keyswitch in the OFF position
- (4) Battery disconnect switch in the open position
- (5) Disconnected battery cables
- (6) Battery
- (7) Electrical/Electronic component
- (8) Minimum distance between the component that is being welded and any electrical/electronic component
- (9) The component that is being welded
- (10) Current path of the welder
- (11) Ground clamp for the welder

5. Connect the welding ground cable directly to the part that will be welded. Place the ground cable as close as possible to the weld in order to reduce the possibility of welding current damage to the following components. Bearings, hydraulic components, electrical components, and ground straps.

Note: If electrical/electronic components are used as a ground for the welder, or electrical/electronic components are located between the welder ground and the weld, current flow from the welder could severely damage the component.

6. Protect the wiring harness from welding debris and spatter.
7. Use standard welding practices to weld the materials.

i04150276

Severe Service Application

Severe service is the application of an engine that exceeds the current published standards for that engine. Perkins maintains standards for the following engine parameters:

- Performance such as power range, speed range, and fuel consumption
- Fuel quality
- Operational Altitude
- Maintenance intervals
- Oil selection and maintenance
- Coolant type and maintenance
- Environmental qualities
- Installation
- The temperature of the fluid in the engine

Refer to the standards for the engine or consult your Perkins dealer or your Perkins distributor in order to determine if the engine is operating within the defined parameters.

Severe service operation can accelerate component wear. Engines that operate under severe conditions may need more frequent maintenance intervals in order to ensure maximum reliability and retention of full service life.

Due to individual applications, it is not possible to identify all of the factors which can contribute to severe service operation. Consult your Perkins dealer or your Perkins distributor for the unique maintenance that is necessary for the engine.

The operating environment, incorrect operating procedures, and incorrect maintenance procedures can be factors which contribute to a severe service application.

Environmental Factors

Ambient temperatures – The engine may be exposed to extended operation in cold environments or hot environments. Valve components can be damaged by carbon buildup if the engine is frequently started and stopped in cold temperatures. Hot intake air reduces engine performance.

Quality of the air – The engine may be exposed to extended operation in an environment that is dirty or dusty, unless the equipment is cleaned regularly. Mud, dirt, and dust can encase components. Maintenance can be difficult. The buildup can contain corrosive chemicals.

Buildup – Compounds, elements, corrosive chemicals, and salt can damage some components.

Altitude – Problems can arise when the engine is operated at altitudes that are higher than the intended settings for that application. Necessary adjustments should be made.

Incorrect Operating Procedures

- Extended operation at low idle
- Frequent hot shutdowns
- Operating at excessive loads
- Operating at excessive speeds
- Operating outside the intended application

Incorrect Maintenance Procedures

- Extending the maintenance intervals
- Failure to use recommended fuel, lubricants, and coolant/antifreeze

i08315124

Maintenance Interval Schedule

When Required

- “ Battery - Replace“ 78
- “ Battery or Battery Cable - Disconnect“ 79
- “ Engine - Clean“ 86
- “ Engine Air Cleaner Element (Dual Element/Canister Type) - Clean/Replace“ 86
- “ Engine Air Cleaner Element (Single Element) - Inspect/Replace“ 89
- “ Engine Oil Sample - Obtain“ 92
- “ Fuel System - Prime“ 96
- “ Radiator - Clean“ 104

Daily

- “ Coolant Level - Check“ 84
- “ Driven Equipment - Check“ 85
- “ Engine Air Cleaner Service Indicator - Inspect“ .. 89
- “ Engine Air Precleaner - Check/Clean“ 90
- “ Engine Oil Level - Check“ 91
- “ Fuel System Primary Filter/Water Separator - Drain“ 100

- “ Walk-Around Inspection“ 105

Every Week

- “ Hoses and Clamps - Inspect/Replace“ 103

Every 50 Service Hours or Weekly

- “ Fuel Tank Water and Sediment - Drain“ 102

Every 400 Service Hours

- “ Aftercooler Core - Clean/Test“ 77

Initial 500 Service Hours

- “ Engine Valve Lash - Check“ 95

Every 500 Service Hours

- “ Fan Clearance - Check“ 95

Every 500 Service Hours or 1 Year

- “ Battery Electrolyte Level - Check“ 78
- “ Cooling System Supplemental Coolant Additive (SCA) - Test/Add“ 85
- “ Engine Air Cleaner Element (Dual Element/Canister Type) - Clean/Replace“ 86
- “ Engine Air Cleaner Element (Single Element) - Inspect/Replace“ 89
- “ Engine Crankcase Breather Element - Replace“ 90
- “ Engine Oil and Filter - Change“ 92
- “ Fuel System Primary Filter (Water Separator) Element - Replace“ 99
- “ Fuel System Secondary Filter - Replace“ 100

Every 1000 Service Hours

- “ Belt Tensioner - Check“ 79
- “ Belt - Inspect“ 80
- “ Engine Valve Lash - Check“ 95
- “ Water Pump - Inspect“ 106

Every 2000 Service Hours

- “ Aftercooler Core - Inspect“ 77
- “ Engine Mounts - Inspect“ 91
- “ Starting Motor - Inspect“ 104

“ Turbocharger - Inspect” 104

Every 3000 Service Hours

“ Alternator - Inspect” 77

“ Alternator and Fan Belts - Replace” 77

**Every 3000 Service Hours or 2
Years**

“ Coolant (Commercial Heavy-Duty) - Change” . . . 80

Every 4000 Service Hours

“ Aftercooler Core - Clean/Test” 77

**Every 6000 Service Hours or 3
Years**

“ Coolant (ELC) - Change” 82

Commissioning

“ Fan Clearance - Check” 95

i01807350

Aftercooler Core - Clean/Test (Air-To-Air Aftercooler)

The air-to-air aftercooler is OEM installed in many applications. Please refer to the OEM specifications for information that is related to the aftercooler.

i04380914

Aftercooler Core - Inspect

Note: Adjust the frequency of cleaning according to the effects of the operating environment.

Inspect the aftercooler for these items: damaged fins, corrosion, dirt, grease, insects, leaves, oil and other debris. Clean the aftercooler, if necessary.

For air-to-air aftercoolers, use the same methods that are used for cleaning radiators.

WARNING

Personal injury can result from air pressure.

Personal injury can result without following proper procedure. When using pressure air, wear a protective face shield and protective clothing.

Maximum air pressure at the nozzle must be less than 205 kPa (30 psi) for cleaning purposes.

Pressurized air is the preferred method for removing loose debris. Direct the air in the opposite direction of the fans air flow. Hold the nozzle approximately 6 mm (.25 inch) away from the fins. Slowly move the air nozzle in a direction that is parallel with the tubes. The pressurized air will remove debris that is between the tubes.

Pressurized water may also be used for cleaning. The maximum water pressure for cleaning purposes must be less than 275 kPa (40 psi). Use pressurized water in order to soften mud. Clean the core from both sides.

Use a degreaser and steam for removal of oil and grease. Clean both sides of the core. Wash the core with detergent and hot water. Thoroughly rinse the core with clean water.

After cleaning, start the engine and accelerate the engine to high idle rpm. This will help in the removal of debris and drying of the core. Stop the engine. Use a light bulb behind the core in order to inspect the core for cleanliness. Repeat the cleaning, if necessary.

Inspect the fins for damage. Bent fins may be opened with a "comb".

Note: If parts of the aftercooler system are repaired or replaced, a leak test is highly recommended. For more information, refer to OEM specification for the aftercooler.

Inspect these items for good condition: welds, mounting brackets, air lines, connections, clamps and seals. Make repairs, if necessary.

i02322311

Alternator - Inspect

Perkins recommends a scheduled inspection of the alternator. Inspect the alternator for loose connections and correct battery charging. Check the ammeter (if equipped) during engine operation in order to ensure correct battery performance and/or correct performance of the electrical system. Make repairs, as required.

Check the alternator and the battery charger for correct operation. If the batteries are correctly charged, the ammeter reading should be very near zero. All batteries should be kept charged. The batteries should be kept warm because temperature affects the cranking power. If the battery is too cold, the battery will not crank the engine. When the engine is not run for long periods of time or if the engine is run for short periods, the batteries may not fully charge. A battery with a low charge will freeze more easily than a battery with a full charge.

i05507877

Alternator and Fan Belts - Replace

Refer to Disassembly and Assembly Manual, "Alternator Belt - Remove and Install".

Ensure that ALL grooved pulley and idlers that the belt operates rotate freely. Ensure that all grooves are clean and free from damage.

i03559623

Battery - Replace

WARNING

Batteries give off combustible gases which can explode. A spark can cause the combustible gases to ignite. This can result in severe personal injury or death.

Ensure proper ventilation for batteries that are in an enclosure. Follow the proper procedures in order to help prevent electrical arcs and/or sparks near batteries. Do not smoke when batteries are serviced.

WARNING

The battery cables or the batteries should not be removed with the battery cover in place. The battery cover should be removed before any servicing is attempted.

Removing the battery cables or the batteries with the cover in place may cause a battery explosion resulting in personal injury.

1. Switch the engine to the OFF position. Remove all electrical loads.
2. Turn off any battery chargers. Disconnect any battery chargers.
3. Ensure that the battery disconnect switch is in the OFF position.
4. Disconnect the NEGATIVE “-” cable from the NEGATIVE “-” battery terminal.
5. Disconnect the POSITIVE “+” cable from the POSITIVE “+” battery terminal.

Note: Always recycle a battery. Never discard a battery. Dispose of used batteries to an appropriate recycling facility.

6. Remove the used battery.
7. Install the new battery.

Note: Before the cables are connected, ensure that the battery disconnect switch is in the OFF position.

8. Connect the POSITIVE “+” cable to the POSITIVE “+” battery terminal.
9. Connect the NEGATIVE “-” cable to the NEGATIVE “-” battery terminal.

10. Turn the battery disconnect switch to the ON position.

i02724529

Battery Electrolyte Level - Check

When the engine is not run for long periods of time or when the engine is run for short periods, the batteries may not fully recharge. Ensure a full charge in order to help prevent the battery from freezing. If batteries are properly charged, ammeter reading should be very near zero, when the engine is in operation.

WARNING

All lead-acid batteries contain sulfuric acid which can burn the skin and clothing. Always wear a face shield and protective clothing when working on or near batteries.

1. Remove the filler caps. Maintain the electrolyte level to the “FULL” mark on the battery.

If the addition of water is necessary, use distilled water. If distilled water is not available use clean water that is low in minerals. Do not use artificially softened water.
2. Check the condition of the electrolyte with the 245 - 5829 Coolant Battery Tester Refractometer.
3. Keep the batteries clean.

Clean the battery case with one of the following cleaning solutions:

- Use a solution of 0.1 kg (0.2 lb) baking soda and 1 L (1 qt) of clean water.
- Use a solution of ammonium hydroxide.

Thoroughly rinse the battery case with clean water.

Use a fine grade of sandpaper to clean the terminals and the cable clamps. Clean the items until the surfaces are bright or shiny. DO NOT remove material excessively. Excessive removal of material can cause the clamps to not fit properly. Coat the clamps and the terminals with 5N - 5561 Silicone Lubricant, petroleum jelly or MPMG.

i07819485

i05507670

Battery or Battery Cable - Disconnect

WARNING

The battery cables or the batteries should not be removed with the battery cover in place. The battery cover should be removed before any servicing is attempted.

Removing the battery cables or the batteries with the cover in place may cause a battery explosion resulting in personal injury.

1. Turn the start switch to the OFF position. Turn the ignition switch (if equipped) to the OFF position and remove the key and all electrical loads.
2. Disconnect the negative battery terminal. Ensure that the cable cannot contact the terminal. When four 12 volt batteries are involved, two negative connections must be disconnected.
3. Remove the positive connection.
4. Clean all disconnected connection and battery terminals.
5. Use a fine grade of sandpaper to clean the terminals and the cable clamps. Clean the items until the surfaces are bright or shiny. DO NOT remove material excessively. Excessive removal of material can cause the clamps to not fit correctly. Coat the clamps and the terminals with a suitable silicone lubricant or petroleum jelly.
6. Tape the cable connections to help prevent accidental starting.
7. Proceed with necessary system repairs.
8. To connect the battery, connect the positive connection before the negative connection.

Belt Tensioner - Check

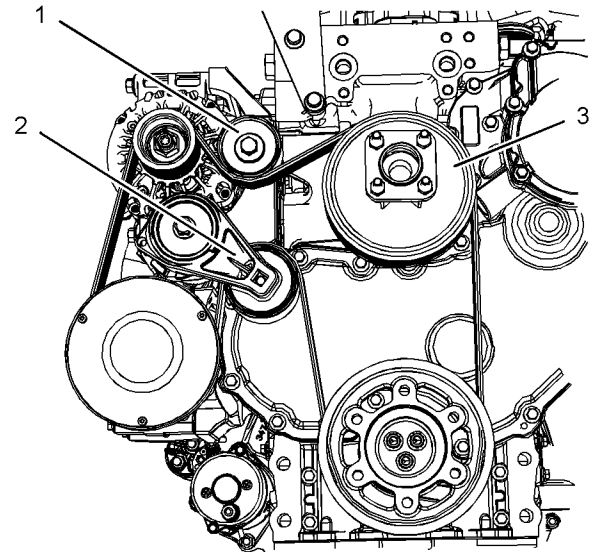

Illustration 37

g03484477

Typical example

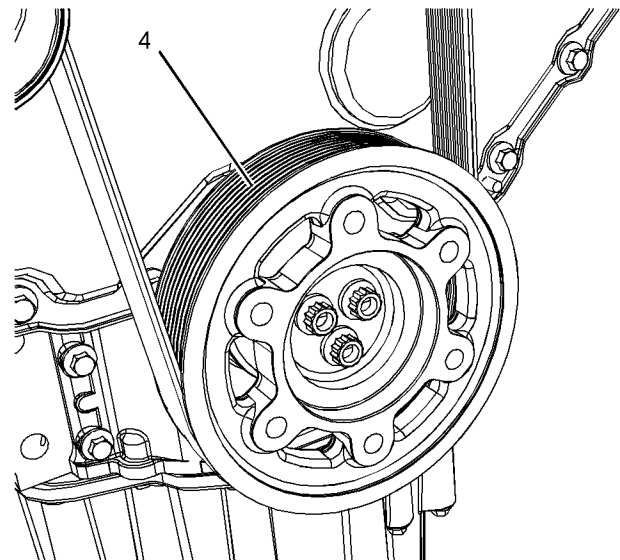

Illustration 38

g03484696

Typical example

Remove the belt. Refer to Disassembly and Assembly, "Alternator Belt - Remove and Install".

Visually inspect the belt tensioner (2) for security and damage. Check that the pulley on the tensioner rotates freely and that the bearing is not loose.

Some engines have an idler pulley (1). Ensure that the idler pulley is securely installed. Visually inspect the idler pulley for damage. Ensure that the idler pulley can rotate freely and that the bearing is not loose.

Check the bearing shaft on the pulley (3) can rotate freely.

Check that the grooves (4) on ALL the grooved pulleys and idlers are clean and free from damage.

If necessary, replace damaged components.

Install the belt. Refer to Disassembly and Assembly, "Alternator Belt - Remove and Install".

i05508310

Belt - Inspect

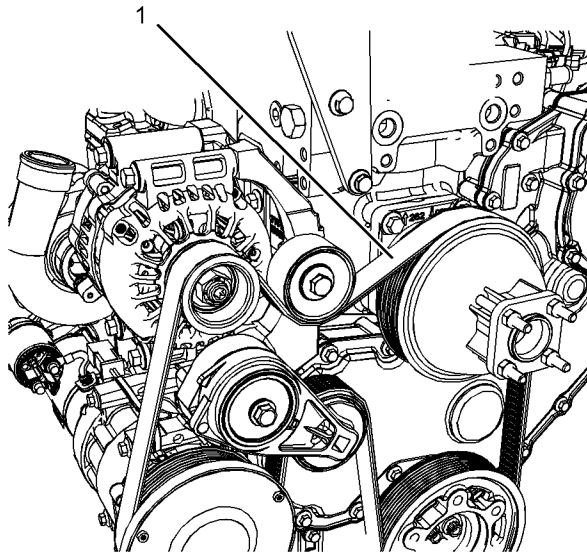

Illustration 39

g03484996

Typical example

To maximize the engine performance, inspect the belt (1) for wear and for cracking. Replace the belt if the belt is worn or damaged.

- Inspect the belt for cracks, splits, glazing, grease, displacement of the cord and evidence of fluid contamination.

The belt must be replaced if the following conditions are present.

- The belt has a crack in more than one rib.
- More than one section of the belt is displaced in one rib of a maximum length of 50.8 mm (2 inch).

To replace the belt, refer to Disassembly and Assembly, "Alternator Belt - Remove and Install". If necessary, replace the belt tensioner. Refer to Disassembly and Assembly, "Alternator Belt - Remove and Install" for the correct procedure.

i05539567

Coolant (Commercial Heavy-Duty) - Change

NOTICE

Care must be taken to ensure that fluids are contained during performance of inspection, maintenance, testing, adjusting and repair of the product. Be prepared to collect the fluid with suitable containers before opening any compartment or disassembling any component containing fluids.

Dispose of all fluids according to Local regulations and mandates.

NOTICE

Keep all parts clean from contaminants.

Contaminants may cause rapid wear and shortened component life.

Clean the cooling system and flush the cooling system before the recommended maintenance interval if the following conditions exist:

- The engine overheats frequently.
- Foaming of the coolant is observed.
- The oil has entered the cooling system and the coolant is contaminated.
- The fuel has entered the cooling system and the coolant is contaminated.

Note: When the cooling system is cleaned, only clean water is needed.

Drain

WARNING

Pressurized System: Hot coolant can cause serious burns. To open the cooling system filler cap, stop the engine and wait until the cooling system components are cool. Loosen the cooling system pressure cap slowly in order to relieve the pressure.

1. Stop the engine and allow the engine to cool. Loosen the cooling system filler cap slowly in order to relieve any pressure. Remove the cooling system filler cap.

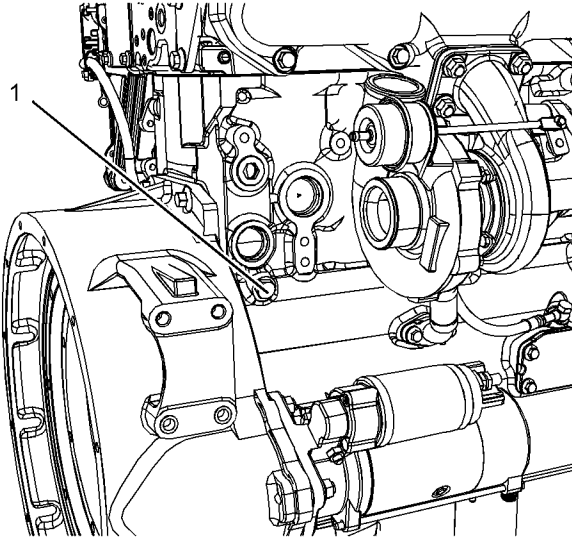

Illustration 40

g03486977

2. Open the drain cock or remove the drain plug (1) on the engine. Open the drain cock or remove the drain plug on the radiator.

Allow the coolant to drain.

NOTICE

Dispose of used engine coolant or recycle. Various methods have been proposed to reclaim used coolant for reuse in engine cooling systems. The full distillation procedure is the only method acceptable by Perkins to reclaim the coolant.

For information regarding the disposal and the recycling of used coolant, consult your Perkins dealer or your Perkins distributor.

Flush

1. Flush the cooling system with clean water in order to remove any debris.
2. Close the drain cock or install the drain plug in the engine. Tighten drain plug in the cylinder block to 40 N·m (29 lb ft). Close the drain cock or install the drain plug on the radiator.

NOTICE

Do not fill the cooling system faster than 5 L (1.3 US gal) per minute to avoid air locks.

Cooling system air locks may result in engine damage.

3. Fill the cooling system with clean water. Install the cooling system filler cap.
4. Start and run the engine at low idle until the temperature reaches 49 to 66 °C (120 to 150 °F).
5. Stop the engine and allow the engine to cool. Loosen the cooling system filler cap slowly in order to relieve any pressure. Remove the cooling system filler cap. Open the drain cock or remove the drain plug on the engine. Open the drain cock or remove the drain plug on the radiator. Allow the water to drain. Flush the cooling system with clean water.

Fill

1. Close the drain cock or clean the drain plug and install the drain plug in the cylinder block. Tighten drain plug in the cylinder block to 40 N·m (29 lb ft). Close the drain cock or install the drain plug on the radiator.

NOTICE

Do not fill the cooling system faster than 5 L (1.3 US gal) per minute to avoid air locks.

Cooling system air locks may result in engine damage.

2. Fill the cooling system with Commercial Heavy-Duty Coolant. Add Supplemental Coolant Additive to the coolant. For the correct amount, refer to the Operation and Maintenance Manual, "Fluid Recommendations" for more information on cooling system specifications. Do not install the cooling system filler cap.
3. Start and run the engine at low idle. Increase the engine rpm to high idle. Run the engine at high idle for 1 minute in order to purge the air from the cavities of the engine block. Decrease the engine speed to low idle. Stop the engine.
4. Check the coolant level. Maintain the coolant level within 13 mm (0.5 inch) below the bottom of the pipe for filling. Maintain the coolant level in the expansion bottle (if equipped) at the correct level.

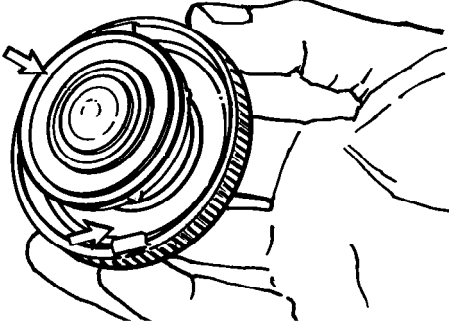

Illustration 41

g00103639

Filler cap

5. Clean the cooling system filler cap and inspect the gasket. If the gasket is damaged, discard the old filler cap and install a new filler cap. If the gasket is not damaged, use a suitable pressurizing pump in order to pressure test the filler cap. The correct pressure is stamped on the face of the filler cap. If the filler cap does not retain the correct pressure, install a new filler cap.
6. Start the engine. Inspect the cooling system for leaks and for correct operating temperature.

Coolant Drain Plug for Cylinder Block

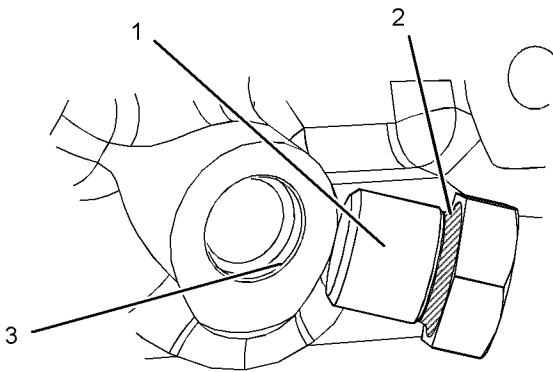

Illustration 42

g03487216

Typical example

The coolant cylinder drain plug (1) has a special concave bead of sealant in position (2) on the drain plug. The drain plug may be reused, but if the sealant is damaged or missing the drain plug must be replaced. Ensure that the sealing surface (3) in the cylinder block is clean and free from dirt, before installing the drain plug.

i05543449

Coolant (ELC) - Change

NOTICE

Care must be taken to ensure that fluids are contained during performance of inspection, maintenance, testing, adjusting and repair of the product. Be prepared to collect the fluid with suitable containers before opening any compartment or disassembling any component containing fluids.

Dispose of all fluids according to Local regulations and mandates.

NOTICE

Keep all parts clean from contaminants.

Contaminants may cause rapid wear and shortened component life.

Clean the cooling system and flush the cooling system before the recommended maintenance interval if the following conditions exist:

- The engine overheats frequently.
- Foaming of the coolant is observed.
- The oil has entered the cooling system and the coolant is contaminated.
- The fuel has entered the cooling system and the coolant is contaminated.

Note: When the cooling system is cleaned, only clean water is needed when the ELC is drained and replaced.

Note: Inspect the water pump and the water temperature regulator after the cooling system has been drained. This inspection is a good opportunity to replace the water pump, the water temperature regulator, and the hoses, if necessary.

Drain

WARNING

Pressurized System: Hot coolant can cause serious burns. To open the cooling system filler cap, stop the engine and wait until the cooling system components are cool. Loosen the cooling system pressure cap slowly in order to relieve the pressure.

1. Stop the engine and allow the engine to cool. Loosen the cooling system filler cap slowly in order to relieve any pressure. Remove the cooling system filler cap.

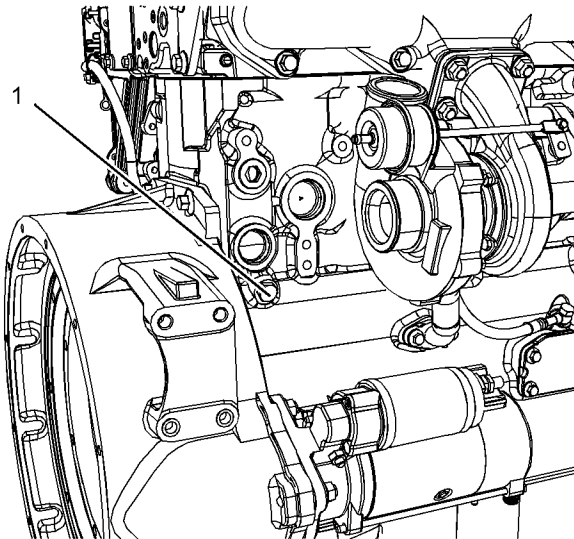

Illustration 43

g03486977

Typical example

2. Open the drain cock or remove the drain plug (1) on the engine. Open the drain cock or remove the drain plug on the radiator.

Allow the coolant to drain.

NOTICE

Dispose of used engine coolant or recycle. Various methods have been proposed to reclaim used coolant for reuse in engine cooling systems. The full distillation procedure is the only method acceptable by Perkins to reclaim the coolant.

For information regarding the disposal and the recycling of used coolant, consult your Perkins dealer or your Perkins distributor.

Flush

1. Flush the cooling system with clean water in order to remove any debris.
2. Close the drain cock or install the drain plug in the engine. Clean the drain plug and then tighten the drain plug in the cylinder block to 40 N·m (29 lb ft). Close the drain cock or install the drain plug on the radiator.

NOTICE

Do not fill the cooling system faster than 5 L (1.3 US gal) per minute to avoid air locks.

Cooling system air locks may result in engine damage.

3. Fill the cooling system with clean water. Install the cooling system filler cap.
4. Start and run the engine at low idle until the temperature reaches 49 to 66 °C (120 to 150 °F).
5. Stop the engine and allow the engine to cool. Loosen the cooling system filler cap slowly in order to relieve any pressure. Remove the cooling system filler cap. Open the drain cock or remove the drain plug on the engine. Open the drain cock or remove the drain plug on the radiator. Allow the water to drain. Flush the cooling system with clean water.

Fill

1. Close the drain cock or install the drain plug on the engine. Tighten drain plug in the cylinder block to 40 N·m (29 lb ft). Close the drain cock or install the drain plug on the radiator.

NOTICE

Do not fill the cooling system faster than 5 L (1.3 US gal) per minute to avoid air locks.

Cooling system air locks may result in engine damage.

2. Fill the cooling system with Extended Life Coolant (ELC). Refer to the Operation and Maintenance Manual, "Fluid Recommendations" for more information on cooling system specifications. Do not install the cooling system filler cap.

3. Start and run the engine at low idle. Increase the engine rpm to high idle. Run the engine at high idle for 1 minute in order to purge the air from the cavities of the engine block. Decrease the engine speed to low idle. Stop the engine.
4. Check the coolant level. Maintain the coolant level within 13 mm (0.5 inch) below the bottom of the pipe for filling. Maintain the coolant level in the expansion bottle (if equipped) at the correct level.

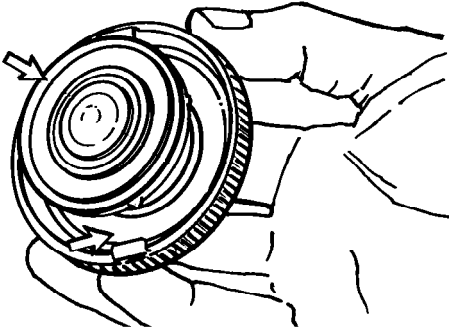

Illustration 44
Filler cap

g00103639

5. Clean the cooling system filler cap and inspect the gasket. If the gasket is damaged, discard the old filler cap and install a new filler cap. If the gasket is not damaged, use a suitable pressurizing pump in order to pressure test the filler cap. The correct pressure is stamped on the face of the filler cap. If the filler cap does not retain the correct pressure, install a new filler cap.
6. Start the engine. Inspect the cooling system for leaks and for correct operating temperature.

Coolant Drain Plug for Cylinder Block

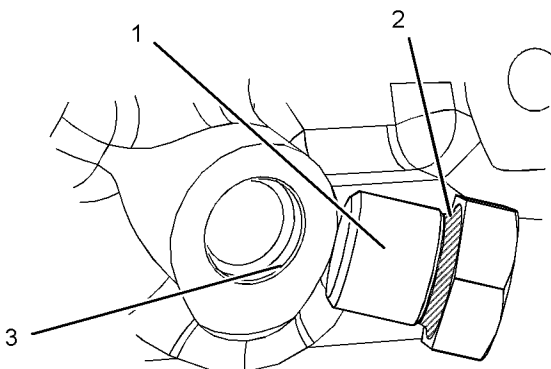

Illustration 45

g03487216

Typical example

The coolant cylinder drain plug (1) has a special concave bead of sealant in position (2) on the drain plug. The drain plug may be reused, but if the sealant is damaged or missing the drain plug must be replaced. Ensure that the sealing surface (3) in the cylinder block is clean and free from dirt, before installing the drain plug.

i05525293

Coolant Level - Check

⚠ WARNING

Pressurized System: Hot coolant can cause serious burns. To open the cooling system filler cap, stop the engine and wait until the cooling system components are cool. Loosen the cooling system pressure cap slowly in order to relieve the pressure.

Check the coolant level when the engine is stopped and the engine has cooled.

NOTICE

When any servicing or repair of the engine cooling system is performed, the procedure must be performed with the engine on level ground. This procedure will allow you to check accurately the coolant level. This procedure will also help in avoiding the risk of introducing an air lock into the coolant system.

1. Remove the cooling system filler cap slowly in order to relieve pressure.
2. Maintain the coolant level at the maximum mark that is correct for your application. If the engine is equipped with a sight glass, maintain the coolant level to the correct level in the sight glass.

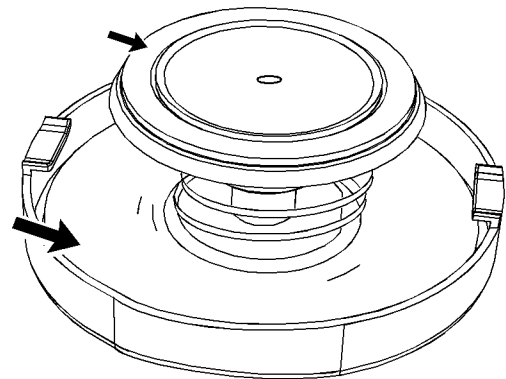

Illustration 46

g03495956

Typical filler cap gaskets

3. Clean the cooling system filler cap and check the condition of the filler cap gaskets. Replace the cooling system filler cap if the filler cap gaskets are damaged. Reinstall the cooling system filler cap.
4. Inspect the cooling system for leaks.

i03644948

Cooling System Supplemental Coolant Additive (SCA) - Test/Add

WARNING

Cooling system coolant additive contains alkali. To help prevent personal injury, avoid contact with the skin and the eyes. Do not drink cooling system coolant additive.

Test for SCA Concentration

Heavy-Duty Coolant/Antifreeze and SCA

NOTICE

Do not exceed the recommended six percent supplemental coolant additive concentration.

Use a Coolant Conditioner Test Kit in order to check the concentration of the SCA.

Add the SCA, If Necessary

NOTICE

Do not exceed the recommended amount of supplemental coolant additive concentration. Excessive supplemental coolant additive concentration can form deposits on the higher temperature surfaces of the cooling system, reducing the engine's heat transfer characteristics. Reduced heat transfer could cause cracking of the cylinder head and other high temperature components. Excessive supplemental coolant additive concentration could also result in radiator tube blockage, overheating, and/or accelerated water pump seal wear. Never use both liquid supplemental coolant additive and the spin-on element (if equipped) at the same time. The use of those additives together could result in supplemental coolant additive concentration exceeding the recommended maximum.

WARNING

Pressurized System: Hot coolant can cause serious burns. To open the cooling system filler cap, stop the engine and wait until the cooling system components are cool. Loosen the cooling system pressure cap slowly in order to relieve the pressure.

NOTICE

When any servicing or repair of the engine cooling system is performed the procedure must be performed with the engine on level ground. This will allow you to accurately check the coolant level. This will also help in avoiding the risk of introducing an air lock into the coolant system.

1. Slowly loosen the cooling system filler cap in order to relieve the pressure. Remove the cooling system filler cap.

Note: Always discard drained fluids according to local regulations.

2. If necessary, drain some coolant from the cooling system into a suitable container in order to allow space for the extra SCA.
3. Add the correct amount of SCA. Refer to the Operation and Maintenance Manual, "Refill Capacities and Recommendations" for more information on SCA requirements.
4. Clean the cooling system filler cap and inspect the gasket. If the gasket is damaged, discard the old filler cap and install a new filler cap. If the gasket is not damaged, use a suitable pressurizing pump in order to pressure test the filler cap. The correct pressure is stamped on the face of the filler cap. If the filler cap does not retain the correct pressure, install a new filler cap.

i00174798

Driven Equipment - Check

Refer to the OEM specifications for more information on the following maintenance recommendations for the driven equipment:

- Inspection
- Adjustment
- Lubrication
- Other maintenance recommendations

Perform any maintenance for the driven equipment which is recommended by the OEM.

i05278929

i07307312

Engine - Clean

WARNING

Personal injury or death can result from high voltage.

Moisture can create paths of electrical conductivity.

Make sure that the electrical system is OFF. Lock out the starting controls and tag the controls "DO NOT OPERATE" .

NOTICE

Accumulated grease and oil on an engine is a fire hazard. Keep the engine clean. Remove debris and fluid spills whenever a significant quantity accumulates on the engine.

Periodic cleaning of the engine is recommended. Steam cleaning the engine will remove accumulated oil and grease. A clean engine provides the following benefits:

- Easy detection of fluid leaks
- Maximum heat transfer characteristics
- Ease of maintenance

Note: Caution must be used to prevent electrical components from being damaged by excessive water when the engine is cleaned. Pressure washers and steam cleaners should not be directed at any electrical connectors or the junction of cables into the rear of the connectors. Avoid electrical components such as the alternator, the starter, and the ECM. Protect the fuel injection pump from fluids to wash the engine.

Ensure that care is taken that the safety labels, emission label, and any information labels are not removed during engine cleaning.

Engine Air Cleaner Element (Dual Element/Canister Type) - Clean/Replace (If Equipped)

NOTICE

Never run the engine without an air cleaner element installed. Never run the engine with a damaged air cleaner element. Do not use air cleaner elements with damaged pleats, gaskets or seals. Dirt entering the engine causes premature wear and damage to engine components. Air cleaner elements help to prevent airborne debris from entering the air inlet.

NOTICE

Never service the air cleaner element with the engine running since this will allow dirt to enter the engine.

Servicing the Air Cleaner Elements

If the air cleaner element becomes plugged, the air can split the material of the air cleaner element. Unfiltered air will drastically accelerate internal engine wear. Your Perkins dealer or your Perkins distributor has the proper air cleaner elements for your application.

- Check the precleaner (if equipped) daily for accumulation of dirt and debris. Remove any dirt and debris, as needed.
- Operating conditions (dust, dirt, and debris) may require more frequent service of the air cleaner element.
- The air cleaner element may be cleaned up to six times if the element has been properly cleaned and inspected.
- The air cleaner element should be replaced at least one time per year. This replacement should be performed regardless of the number of cleanings.

Replace the dirty paper air cleaner elements with clean air cleaner elements. Before installation, check the air cleaner elements thoroughly for tears and/or holes in the filter material. Inspect the gasket or the seal of the air cleaner element for damage. Maintain a supply of suitable air cleaner elements for replacement purposes.

Dual Element Air Cleaners

The dual element air cleaner contains a primary air cleaner element and a secondary air cleaner element. The primary air cleaner element can be used up to six times if the element has been properly cleaned and inspected. The primary air cleaner element should be replaced at least one time per year. This replacement should be performed regardless of the number of cleanings.

The secondary air cleaner element is not serviceable or washable. The secondary air cleaner element should be removed and discarded for every three cleanings of the primary air cleaner element. When the engine is operating in environments that are dusty or dirty, air cleaner elements may require more frequent replacement.

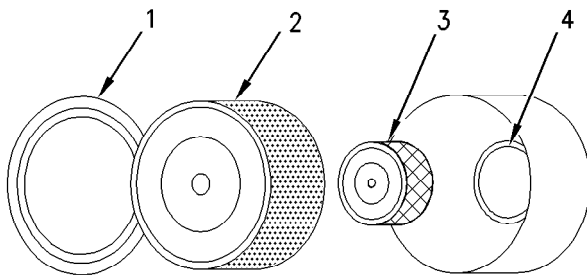

Illustration 47

g00736431

- (1) Cover
(2) Primary air cleaner element
(3) Secondary air cleaner element
(4) Air inlet for the turbocharger

1. Remove the cover. Remove the primary air cleaner element.
 2. The secondary air cleaner element should be removed and discarded for every three cleanings of the primary air cleaner element.
- Note:** Refer to “Cleaning the Primary Air Cleaner Elements”.
3. Cover the air inlet to the turbocharger with tape in order to keep out dirt.
 4. Clean the inside of the air cleaner cover and body with a clean, dry cloth.
 5. Remove the tape from the air inlet of the turbocharger. Install the secondary air cleaner element. Install a primary air cleaner element that is new or cleaned.
 6. Install the air cleaner cover.

7. Reset the air cleaner service indicator.

Cleaning the Primary Air Cleaner Elements

NOTICE

Observe the following guidelines if you attempt to clean the filter element:

Do not tap or strike the filter element in order to remove dust.

Do not wash the filter element.

Use low pressure compressed air in order to remove the dust from the filter element. Air pressure must not exceed 207 kPa (30 psi). Direct the air flow up the pleats and down the pleats from the inside of the filter element. Take extreme care in order to avoid damage to the pleats.

Do not use air filters with damaged pleats, gaskets, or seals. Dirt entering the engine will cause damage to engine components.

The primary air cleaner element can be used up to six times if the element has been properly cleaned and inspected. When the primary air cleaner element is cleaned, check for rips or tears in the filter material. The primary air cleaner element should be replaced at least one time per year. This replacement should be performed regardless of the number of cleanings.

Use clean primary air cleaner elements while dirty elements are being cleaned.

NOTICE

Do not clean the air cleaner elements by bumping or tapping. This could damage the seals. Do not use elements with damaged pleats, gaskets or seals. Damaged elements will allow dirt to pass through. Engine damage could result.

Visually inspect the primary air cleaner elements before cleaning. Inspect the air cleaner elements for damage to the seal, the gaskets, and the outer cover. Discard any damaged air cleaner elements.

There are two common methods that are used to clean primary air cleaner elements:

- Pressurized air
- Vacuum cleaning

Pressurized Air

Pressurized air can be used to clean primary air cleaner elements that have not been cleaned more than two times. Pressurized air will not remove deposits of carbon and oil. Use filtered, dry air with a maximum pressure of 207 kPa (30 psi).

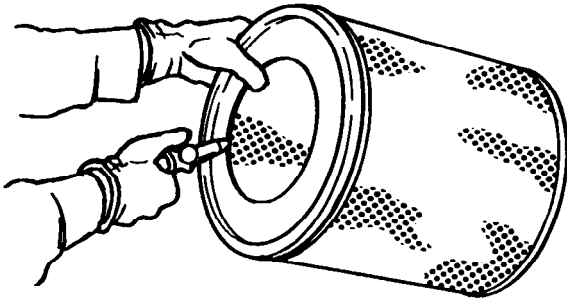

Illustration 48

g00281692

Note: When the primary air cleaner elements are cleaned, always begin with the clean side (inside) in order to force dirt particles toward the dirty side (outside).

Aim the hose so that the air flows inside the element along the length of the filter to prevent damage to the paper pleats. Do not aim the stream of air directly at the primary air cleaner element. Dirt could be forced further into the pleats.

Note: Refer to “Inspecting the Primary Air Cleaner Elements”.

Vacuum Cleaning

Vacuum cleaning is a good method for cleaning primary air cleaner elements which require daily cleaning because of a dry, dusty environment. Cleaning with pressurized air is recommended prior to vacuum cleaning. Vacuum cleaning will not remove deposits of carbon and oil.

Note: Refer to “Inspecting the Primary Air Cleaner Elements”.

Inspecting the Primary Air Cleaner Elements

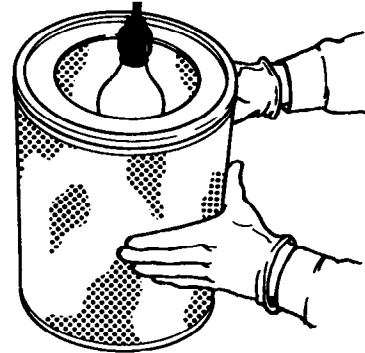

Illustration 49

g00281693

Inspect the clean, dry primary air cleaner element. Use a 60w blue light in a dark room or in a similar facility. Place the blue light in the primary air cleaner element. Rotate the primary air cleaner element. Inspect the primary air cleaner element for tears and/or holes. Inspect the primary air cleaner element for light that may show through the filter material. To confirm the result, compare the primary air cleaner element to a new air cleaner element that has the same part number.

Do not use a primary air cleaner element that has any tears and/or holes in the filter material. Do not use a primary air cleaner element with damaged pleats, gaskets, or seals. Discard damaged primary air cleaner elements.

Storing Primary Air Cleaner Elements

If a primary air cleaner element that passes inspection will not be used, the primary air cleaner element can be stored for future use.

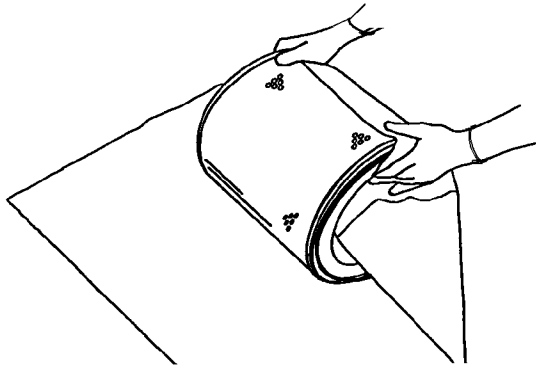

Illustration 50

g03376753

Typical example

Do not use paint, a waterproof cover, or plastic as a protective covering for storage. An air flow restriction may result. To protect against dirt and damage, wrap the primary air cleaner elements in Volatile Corrosion Inhibited (VCI) paper.

Place the primary air cleaner element into a box for storage. For identification, mark the outside of the box and mark the primary air cleaner element. Include the following information:

- Date of cleaning
- Number of cleanings

Store the box in a dry location.

i01432811

Engine Air Cleaner Element (Single Element) - Inspect/Replace

Perform the Operation and Maintenance Manual, "Engine Air Cleaner Service Indicator-Inspect" procedure and perform the Operation and Maintenance Manual, "Engine Air Precleaner Check/Clean" procedure (if equipped) before performing the following procedure.

NOTICE

Never run the engine without an air cleaner element installed. Never run the engine with a damaged air cleaner element. Do not use air cleaner elements with damaged pleats, gaskets or seals. Dirt entering the engine causes premature wear and damage to engine components. Air cleaner elements help to prevent airborne debris from entering the air inlet.

NOTICE

Never service the air cleaner element with the engine running since this will allow dirt to enter the engine.

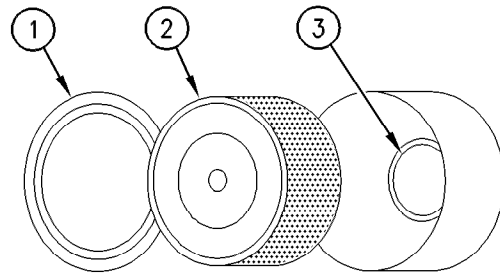

Illustration 51

g00310664

- (1) Air cleaner cover
(2) Air filter element
(3) Air inlet

1. Remove air cleaner cover (1) and remove air filter element (2).
2. Cover air inlet (3) with tape or a clean cloth so that debris cannot enter the air inlet.
3. Clean the inside of air cleaner cover (1). Clean the body that holds the air cleaner element.
4. Inspect the replacement element for the following items: damage, dirt and debris.
5. Remove the seal from the opening of the air inlet.
6. Install a clean, undamaged air filter element (2).
7. Install air cleaner cover (1).
8. Reset the air cleaner service indicator.

i02335405

Engine Air Cleaner Service Indicator - Inspect

Some engines may be equipped with a different service indicator.

Maintenance Section
Engine Air Precleaner - Check/Clean

Some engines are equipped with a differential gauge for inlet air pressure. The differential gauge for inlet air pressure displays the difference in the pressure that is measured before the air cleaner element and the pressure that is measured after the air cleaner element. As the air cleaner element becomes dirty, the pressure differential rises. If your engine is equipped with a different type of service indicator, follow the OEM recommendations in order to service the air cleaner service indicator.

The service indicator may be mounted on the air cleaner element or in a remote location.

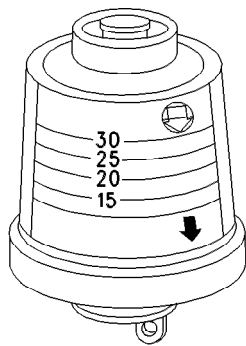

Illustration 52

g00103777

Typical service indicator

Observe the service indicator. The air cleaner element should be cleaned or the air cleaner element should be replaced when one of the following conditions occur:

- The yellow diaphragm enters the red zone.
- The red piston locks in the visible position.

Test the Service Indicator

Service indicators are important instruments.

- Check for ease of resetting. The service indicator should reset in less than three pushes.
- Check the movement of the yellow core when the engine is accelerated to the engine rated speed. The yellow core should latch at the greatest vacuum that is attained.

If the service indicator does not reset easily, or if the yellow core does not latch at the greatest vacuum, the service indicator should be replaced. If the new service indicator will not reset, the hole for the service indicator may be restricted.

The service indicator may need to be replaced frequently in environments that are severely dusty.

i07819526

Engine Air Precleaner - Check/Clean

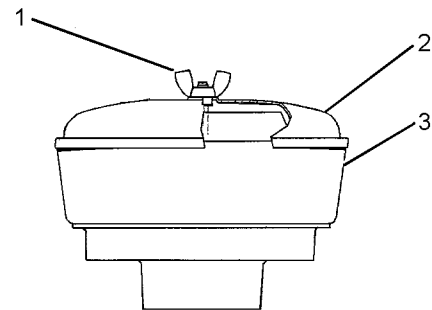

Illustration 53

g01453058

Typical engine air pre-cleaner

- (1) Wing nut
- (2) Cover
- (3) Body

Remove wing nut (1) and cover (2). Check for an accumulation of dirt and debris in body (3). Clean the body, if necessary.

After cleaning the pre-cleaner, install cover (2) and wing nut (1).

Note: When the engine is operated in dusty conditions, more frequent cleaning is required.

Do not tap or strike the air cleaner element.

i05543530

Engine Crankcase Breather Element - Replace

NOTICE

Ensure that the engine is stopped before any servicing or repair is performed.

1. Place a container under canister (2).
2. Clean the outside of the canister. Using a suitable tool, remove the canister.

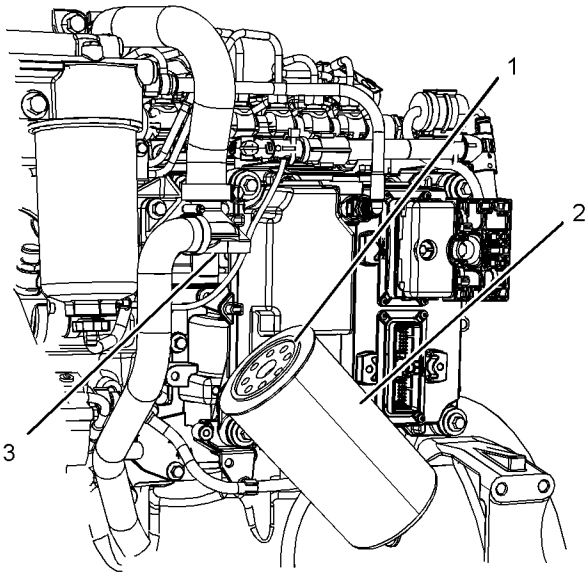

Illustration 54

g03498157

Typical example

3. Lubricate O ring seal (1) on the new canister with clean engine lubricating oil.
4. Install the new canister. Spin on the canister until the O ring seal contacts the base (3). Rotate the canister $\frac{3}{4}$ of a full turn.
5. Remove the container. Dispose of the old canister and any split oil in accordance with local regulations.

i07819538

Engine Mounts - Inspect

Note: The engine mounts may not have been supplied by Perkins. Refer to the Original Equipment Manufacturer (OEM) information for further details on the engine mounts and the correct bolt torque.

Inspect the engine mounts for deterioration and for correct bolt torque. Excessive engine vibration can be caused by the following conditions:

- Incorrect mounting of the engine
- Deterioration of the engine mounts
- Loose engine mounts

Any engine mount that shows deterioration should be replaced. Refer to the OEM information for the recommended torques.

When the engine mounts are supplied by Perkins the maintenance procedure will be supplied in the Disassembly and Assembly manual for your engine.

i05300117

Engine Oil Level - Check

⚠ WARNING

Hot oil and hot components can cause personal injury. Do not allow hot oil or hot components to contact the skin.

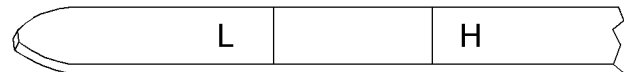

Illustration 55

g02173847

"L" Low
"H" High

NOTICE

Perform this maintenance with the engine stopped.

Note: Ensure that the engine is either level or that the engine is in the normal operating position in order to obtain a true level indication.

Note: After the engine has been switched OFF, wait for 10 minutes in order to allow the engine oil to drain to the oil pan before checking the oil level.

1. Maintain the oil level between the mark (L) and the mark (H) on the engine oil dipstick. Do not fill the crankcase above the "H".

NOTICE

Operating your engine when the oil level is above the "H" mark could cause your crankshaft to dip into the oil. The air bubbles created from the crankshaft dipping into the oil reduces the oils lubricating characteristics and could result in the loss of power.

2. Remove the oil filler cap and add oil, if necessary. Clean the oil filler cap. Install the oil filler cap.

If an increase in the oil level is noticed, refer to Troubleshooting, "Oil Contains Fuel".

i01907674

Engine Oil Sample - Obtain

The condition of the engine lubricating oil may be checked at regular intervals as part of a preventive maintenance program. Perkins include an oil sampling valve as an option. The oil sampling valve (if equipped) is included in order to regularly sample the engine lubricating oil. The oil sampling valve is positioned on the oil filter head or the oil sampling valve is positioned on the cylinder block.

Perkins recommends using a sampling valve in order to obtain oil samples. The quality and the consistency of the samples are better when a sampling valve is used. The location of the sampling valve allows oil that is flowing under pressure to be obtained during normal engine operation.

Obtain the Sample and the Analysis

WARNING

Hot oil and hot components can cause personal injury. Do not allow hot oil or hot components to contact the skin.

In order to help obtain the most accurate analysis, record the following information before an oil sample is taken:

- The date of the sample
- Engine model
- Engine number
- Service hours on the engine
- The number of hours that have accumulated since the last oil change
- The amount of oil that has been added since the last oil change

Ensure that the container for the sample is clean and dry. Also ensure that the container for the sample is clearly labelled.

To ensure that the sample is representative of the oil in the crankcase, obtain a warm, well mixed oil sample.

To avoid contamination of the oil samples, the tools and the supplies that are used for obtaining oil samples must be clean.

The sample can be checked for the following: the quality of the oil, the existence of any coolant in the oil, the existence of any ferrous metal particles in the oil and the existence of any nonferrous metal particles in the oil.

i05543672

Engine Oil and Filter - Change

WARNING

Hot oil and hot components can cause personal injury. Do not allow hot oil or hot components to contact the skin.

NOTICE

Care must be taken to ensure that fluids are contained during performance of inspection, maintenance, testing, adjusting and repair of the product. Be prepared to collect the fluid with suitable containers before opening any compartment or disassembling any component containing fluids.

Dispose of all fluids according to local regulations and mandates.

NOTICE

Keep all parts clean from contaminants.

Contaminants may cause rapid wear and shortened component life.

Do not drain the engine lubricating oil when the engine is cold. As the engine lubricating oil cools, suspended waste particles settle on the bottom of the oil pan. The waste particles are not removed with draining cold oil. Drain the oil pan with the engine stopped. Drain the oil pan with the oil warm. This draining method allows the waste particles that are suspended in the oil to be drained properly.

Failure to follow this recommended procedure will cause the waste particles to be recirculated through the engine lubrication system with the new oil.

Drain the Engine Lubricating Oil

Note: Ensure that the vessel that will be used is large enough to collect the waste oil.

After the engine has been run at the normal operating temperature, stop the engine. Use one of the following methods to drain the engine oil pan:

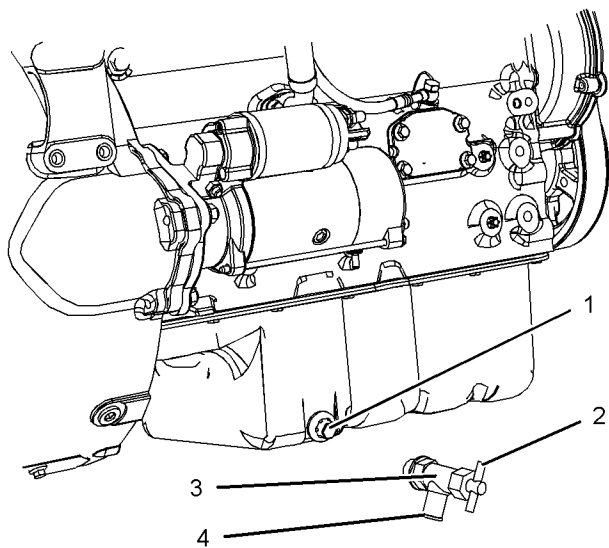

Illustration 56

g03499937

Typical example

1. Remove the drain plug (1) in order to allow the oil to drain.
 - a. If the engine as an oil drain valve (3) installed, install a suitable flexible hose onto the valve (4). Turn the handle (2) counter clockwise and allow the oil to drain.
 - b. When the oil has drained, turn the handle clockwise and tighten securely. Remove the flexible hose.

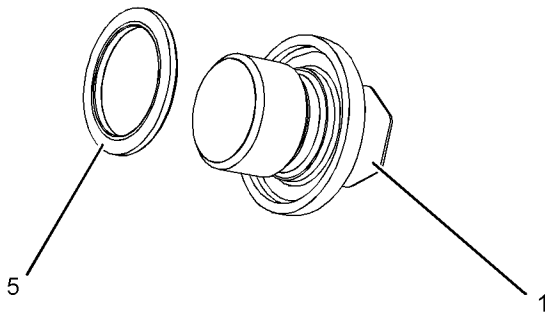

Illustration 57

g03350650

Typical example

2. Remove O ring seal (5) and install new O ring seal.

3. Install drain plug and tighten drain plug to a torque of 34 N·m (25 lb ft).

Replace the Oil Filter

NOTICE

Perkins oil filters are manufactured to Perkins specifications. Use of an oil filter that is not recommended by Perkins could result in severe damage to the engine bearings, crankshaft, etc., as a result of the larger waste particles from unfiltered oil entering the engine lubricating system. Only use oil filters recommended by Perkins.

1. Remove the oil filter with a suitable tool.

Note: The following actions can be carried out as part of the preventive maintenance program.

2. Cut the oil filter open with a suitable tool. Break apart the pleats and inspect the oil filter for metal debris. An excessive amount of metal debris in the oil filter may indicate early wear or a pending failure.

Use a magnet to differentiate between the ferrous metals and the nonferrous metals that are found in the oil filter element. Ferrous metals may indicate wear on the steel and cast iron parts of the engine.

Nonferrous metals may indicate wear on the aluminum parts, brass parts or bronze parts of the engine. Parts that may be affected include the following items: main bearings, rod bearings and turbocharger bearings.

Due to normal wear and friction, it is not uncommon to find small amounts of debris in the oil filter.

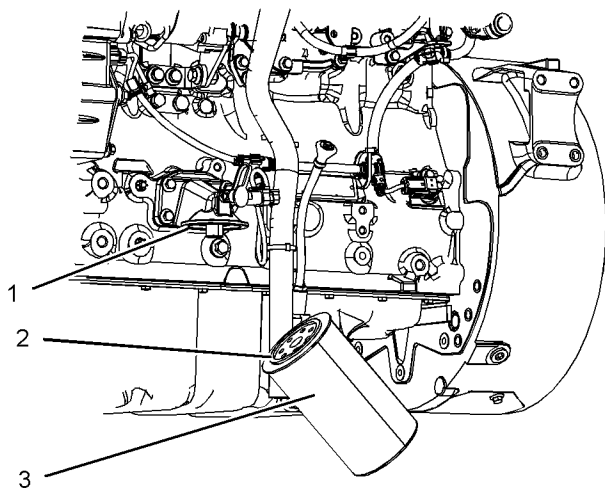

Illustration 58

g03499938

Typical example

3. Clean the sealing surface of the oil filter base (1)
4. Apply clean engine oil to the O ring seal (2) on the new oil filter.

NOTICE

Do not fill the oil filters with oil before installing them. This oil would not be filtered and could be contaminated. Contaminated oil can cause accelerated wear to engine components.

5. Install the engine oil filter. Spin on the new oil filter until the O ring seal contacts the oil filter base. Rotate the oil filter $\frac{3}{4}$ of a full turn.

Horizontally Installed Oil Filter

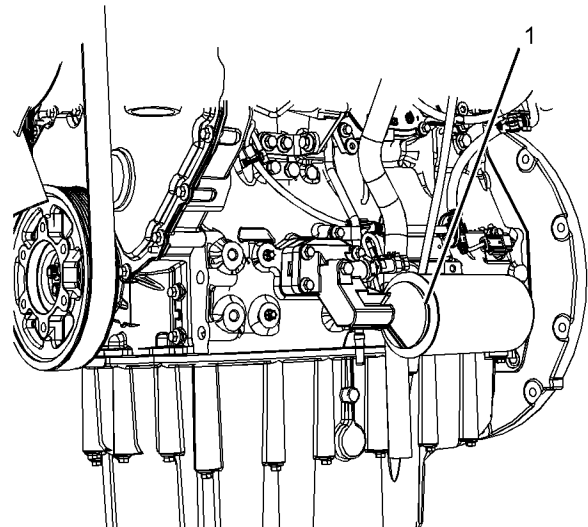

Illustration 59

g03499939

(1) Horizontal oil filter

Before removing the horizontal oil filter, place a suitable container below oil filter. Loosen oil filter and allow oil to drain from oil filter before removing oil filter. For installation of the oil filter follow step 1 to step 5. Remove container.

Fill the Oil Pan

1. Remove the oil filler cap. Refer to this Operation and Maintenance Manual, "Fluid Recommendations" for more information on suitable oils. Fill the oil pan with the correct amount of new engine lubricating oil. Refer to this Operation and Maintenance Manual, "Refill Capacities" for more information on refill capacities.

NOTICE

If equipped with an auxiliary oil filter system or a remote filter system, follow the OEM or the filter manufacturer's recommendations. Under filling or over filling the crankcase with oil can cause engine damage.

2. Start the engine and run the engine at "LOW IDLE" for 2 minutes. Perform this procedure in order to ensure that the lubrication system has oil and that the oil filters are filled. Inspect the oil filter for oil leaks.
3. Stop the engine and allow the oil to drain back to the oil pan for a minimum of 10 minutes.

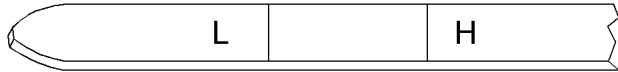

Illustration 60

g02173847

"L" Low

"H" High

4. Remove the engine oil level gauge in order to check the oil level. Maintain the oil level between the "L" and "H" marks on the engine oil level gauge. Do not fill the crankcase above the "H" mark.

i05277638

Engine Valve Lash - Check

This maintenance is recommended by Perkins as part of a lubrication and preventive maintenance schedule in order to help provide maximum engine life.

NOTICE

Only qualified service personnel should perform this maintenance. Refer to the Service Manual or your authorized Perkins dealer or your Perkins distributor for the complete valve lash adjustment procedure.

Operation of Perkins engines with incorrect valve lash can reduce engine efficiency, and also reduce engine component life.

WARNING

Ensure that the engine cannot be started while this maintenance is being performed. To help prevent possible injury, do not use the starting motor to turn the flywheel.

Hot engine components can cause burns. Allow additional time for the engine to cool before measuring/adjusting valve lash clearance.

Ensure that the engine is stopped before measuring the valve lash. To obtain an accurate measurement, allow the valves to cool before this maintenance is performed.

Refer to Systems Operation, Testing, and Adjusting, "Engine Valve Lash - Inspect/Adjust" for more information.

i05531410

Fan Clearance - Check

There are different types of cooling systems. Refer to the OEM for information on clearance for the fan.

Ensure that the engine is stopped. Ensure that the cooling system is full. The clearance between the cover (1) and the fan (2) will require checking. The gap (A) between the edge of the cover and the tip of the fan blade must be checked in four equally spaced positions.

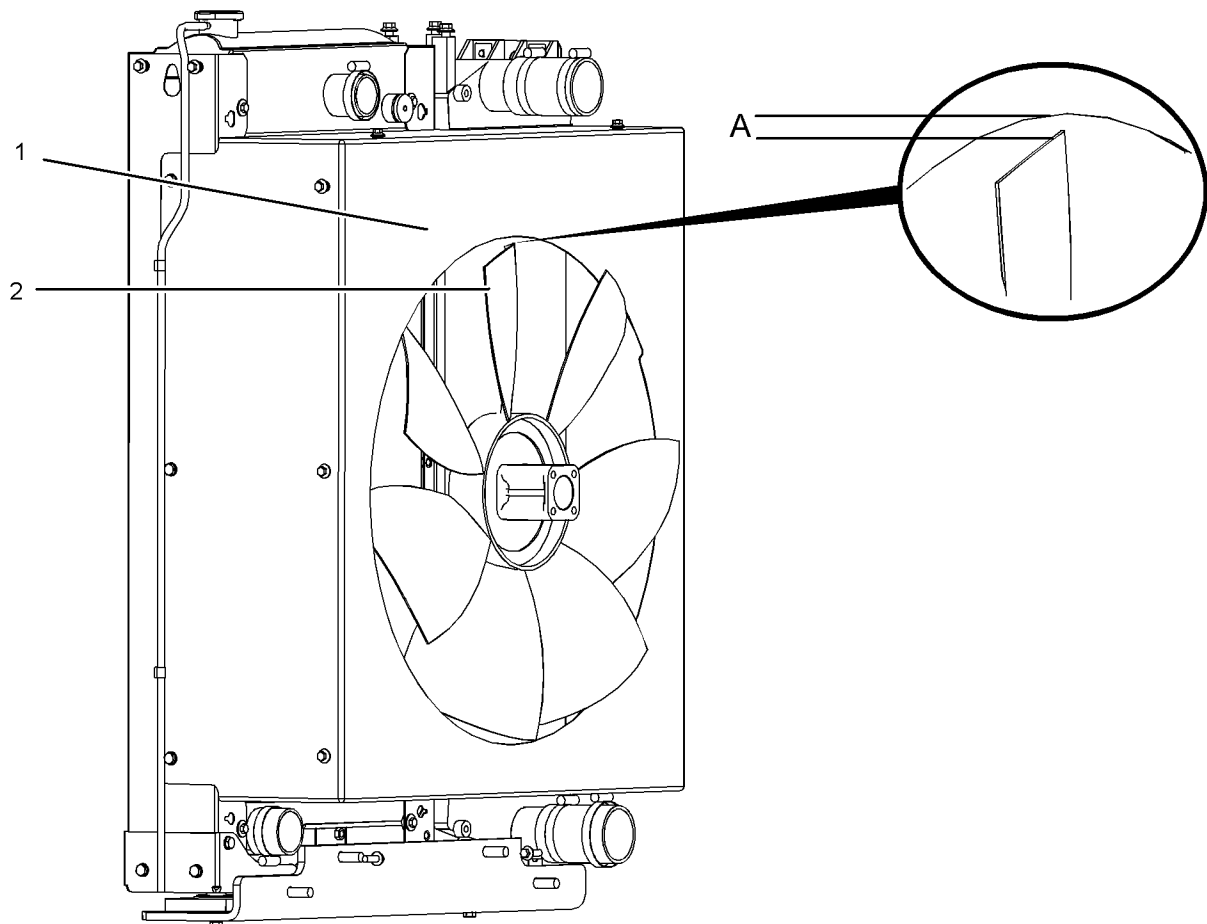

Illustration 61

g01348394

Typical example

Adjustment of the cover will change the clearance (gap) between the edge of the cover and the tip of the fan blade. Ensure that the cover is centralized to the fan.

The maximum clearance is 12.5 mm (0.4921 inch).
The minimum clearance is 6 mm (0.2362 inch).

i05543793

Fuel System - Prime

WARNING

Contact with high pressure fuel may cause fluid penetration and burn hazards. High pressure fuel spray may cause a fire hazard. Failure to follow these inspection, maintenance and service instructions may cause personal injury or death.

Refer to the Operation and Maintenance Manual , “General Hazard Information and High Pressure Fuel Lines” before adjustments and repairs are performed.

Note: Refer to Testing and Adjusting Manual , “Cleanliness of Fuel System Components” for detailed information on the standards of cleanliness that must be observed during ALL work on the fuel system.

Ensure that all adjustments and repairs are performed by authorized personnel that have had the correct training.

NOTICE

Do not crank the engine continuously for more than 30 seconds. Allow the starting motor to cool for two minutes before cranking the engine again.

If air enters the fuel system, the air must be purged from the fuel system before the engine can be started. Air can enter the fuel system when the following events occur:

- The fuel tank is empty or the fuel tank has been partially drained.
- The low-pressure fuel lines are disconnected.
- A leak exists in the low-pressure fuel system.
- The fuel filter has been replaced.
- The engine has not been in use for an extended period.

Hand Fuel Priming Pump

DO NOT loosen the high-pressure fuel lines in order to purge air from the fuel system. This procedure is not required.

Use the following procedures in order to remove air from the fuel system:

1. Ensure that the fuel system is in working order to remove air from the fuel system. Ensure that the primary filter is clean and free from dirt.
2. Check that the fuel supply valve (if equipped) is in the ON position.

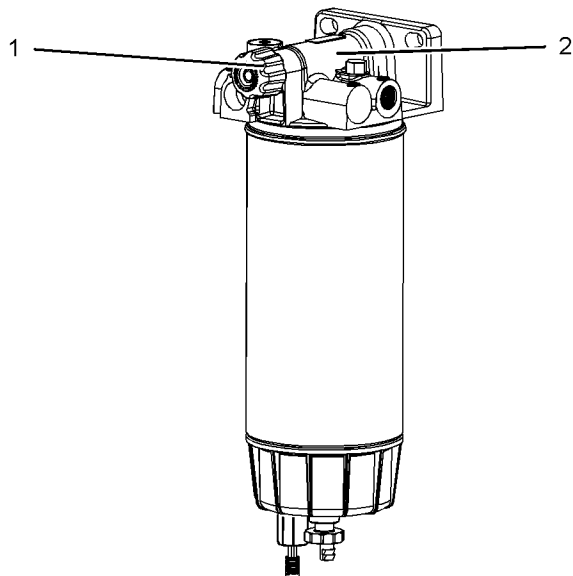

Illustration 62

g03352705

3. Unlock priming pump handle (1) by turning handle counterclockwise.

Note: During priming the hand pressure required to prime the fuel system will increase.

4. Operate the hand priming pump, the fuel system will require approximately 200 depression of the pump before the system will be primed. Lock and priming handle by securing the handle into the body of the pump (2). Push handle in and turn handle clockwise to lock.

Note: Ensure priming handle (1) is locked correctly into place. If the priming handle is not locked into place, fuel flow to the fuel system will be obstructed.

5. Operate the engine starter and crank the engine. After the engine has started, operate the engine at a low idle for a minimum of 5 minutes. Operating the engine at a low idle will help ensure that the air has been removed from the fuel system.
6. If the engine will not start, repeat steps 2 to step 5.

After the engine has stopped, you must wait for 10 minutes in order to allow the fuel pressure to be purged from the high-pressure fuel lines before any service or repair is performed on the engine fuel lines. If necessary, perform minor adjustments. Repair any leaks from the low-pressure fuel system and from the cooling, lubrication, or air systems. Replace any high-pressure fuel line that has leaked. Refer to Disassembly and Assembly, "Fuel Injection Lines - Install".

If you inspect the engine in operation, always use the proper inspection procedure in order to avoid a fluid penetration hazard. Refer to Operation and Maintenance Manual, "General hazard Information".

NOTICE

The low-pressure fuel system can be pressurized for a time period after the engine has stopped operating. The operating pressure of the low-pressure fuel system can be 500 kPa (73 psi). The secondary fuel filters should be drained before any maintenance of the low-pressure fuel system is carried out.

If the engine will not start, refer to Troubleshooting, "Engine Cranks but will not Start".

Electric Prime

NOTICE

Do not crank the engine continuously for more than 30 seconds. Allow the starting motor to cool for two minutes before cranking the engine again.

DO NOT loosen the high-pressure fuel lines in order to purge air from the fuel system. This procedure is not required.

1. Ensure that the fuel system is in working order. Check that the fuel supply valve (if equipped) is in the ON position.

Maintenance Section
Fuel System - Prime

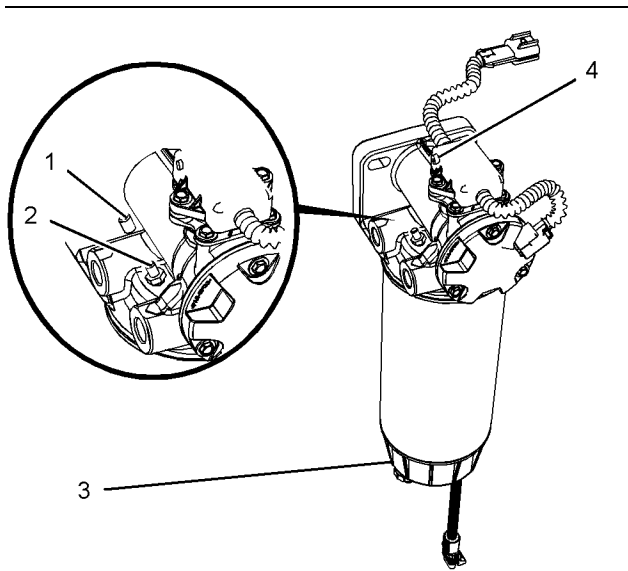

Illustration 63

g03409849

2. Ensure that the battery disconnect switch is in the ON position. Ensure that the keyswitch is in the OFF position.
3. Remove the protection cap (1). Depress valve (2) in order to purge air. Perkins recommend that a tire inflator with a suitable length of clear hose attached to be used. Refer to illustration 64 .

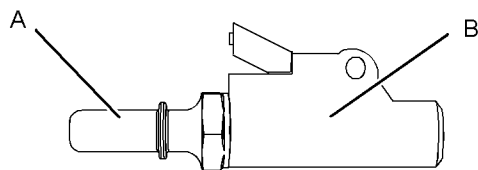

Illustration 64

g02948436

- (A) Connection for clear hose
(B) Inflator

Note: The electric priming pump will only operate with the keyswitch in the OFF position.

4. With tool (B) installed to valve (2) press button (4) and keep the button depressed. The button will illuminate and the priming pump will start to operate.
 5. When fuel has filled the bowl at the bottom of the filter (3), the tool (B) can be removed. Ensure that the protection cap (1) is install. The electric priming pump will stop once the button is released.
 6. Press again the button (4) and keep the button depressed for approximately 2 minutes. After the 2 minutes, the fuel system will be primed and the engine is ready to start.
 7. Start the engine, refer to this Operation and Maintenance Manual, "Starting the Engine or Cold Weather Starting" for more information.
 8. If the engine will not start repeat step 6 to step 7 Ensure that the keyswitch is in the OFF position during fuel system prime.
- After the engine has stopped, you must wait for 10 minutes in order to allow the fuel pressure to be purged from the high-pressure fuel lines before any service or repair is performed on the engine fuel lines. If necessary, perform minor adjustments. Repair any leaks from the low-pressure fuel system and from the cooling, lubrication, or air systems. Replace any high-pressure fuel line that has leaked. Refer to Disassembly and Assembly, "Fuel Injection Lines - Install".
 - If you inspect the engine in operation, always use the proper inspection procedure in order to avoid a fluid penetration hazard. Refer to Operation and Maintenance Manual, "General hazard Information".
 - If the engine will not start, refer to Troubleshooting, "Engine Cranks but will not Start".

NOTICE

The low-pressure fuel system can be pressurized for a time period after the engine has stopped operating. The operating pressure of the low-pressure fuel system can be 500 kPa (73 psi). The secondary fuel filters should be drained before any maintenance of the low-pressure fuel system is carried out.

i05294273

Fuel System Primary Filter (Water Separator) Element - Replace

WARNING

Fuel leaked or spilled onto hot surfaces or electrical components can cause a fire. To help prevent possible injury, turn the start switch off when changing fuel filters or water separator elements. Clean up fuel spills immediately.

Note: Refer to Testing and Adjusting Manual , “Cleanliness of Fuel System Components” for detailed information on the standards of cleanliness that must be observed during ALL work on the fuel system.

NOTICE

Ensure that the engine is stopped before any servicing or repair is performed.

1. Turn the fuel supply valve (if equipped) to the OFF position before performing this maintenance.
2. Place a suitable container under the water separator. Clean any spilled fuel. Clean the outside of the water separator.

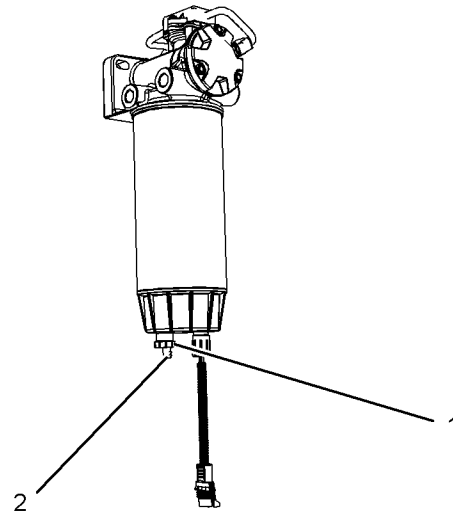

Illustration 65

g03352638

Typical example

3. Install a suitable tube onto connection (2) and open drain valve (1) and drain the filter. Allow the fluid to drain into the container. Remove the tube.

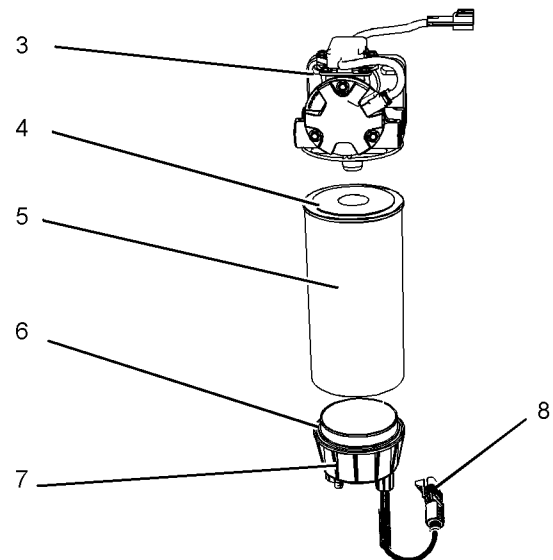

Illustration 66

g03352754

Typical example

4. Disconnect the electrical connector (8) and by hand remove connecting bowl (7). Remove the old O ring seal (6). Clean connecting bowl (7).
5. Use a suitable tool in order to remove the fuel filter (5).

6. Lubricate the O ring seal (4) with clean engine oil on the new filter. Install the new spin on fuel filter (5). Spin on the filter until the O ring seal contacts the filter base (3). The filter will require a $\frac{3}{4}$ of a full turn.
7. Install new O ring seal (6) onto connecting bowl (7). Lubricate the O ring seal (6) with clean engine oil and tighten the connecting bowl by hand. When the O ring seal contacts the filter, tighten the connecting bowl $\frac{3}{4}$ of a full turn.
8. Install the electrical connector (8). Remove the container and dispose of the fuel in accordance with local regulations. If necessary, turn the fuel supply valve to the ON position.
9. The secondary filter must be replaced at the same time as the primary filter. Refer to the Operation and Maintenance Manual , "Fuel System Secondary Filter - Replace".

i05570811

Fuel System Primary Filter/ Water Separator - Drain

WARNING

Fuel leaked or spilled onto hot surfaces or electrical components can cause a fire. To help prevent possible injury, turn the start switch off when changing fuel filters or water separator elements. Clean up fuel spills immediately.

NOTICE

Ensure that the engine is stopped before any servicing or repair is performed.

NOTICE

The water separator can be under suction during normal engine operation. Ensure that the drain valve is tightened securely to help prevent air from entering the fuel system.

Use the same method when draining the primary fuel filter with a hand priming pump installed.

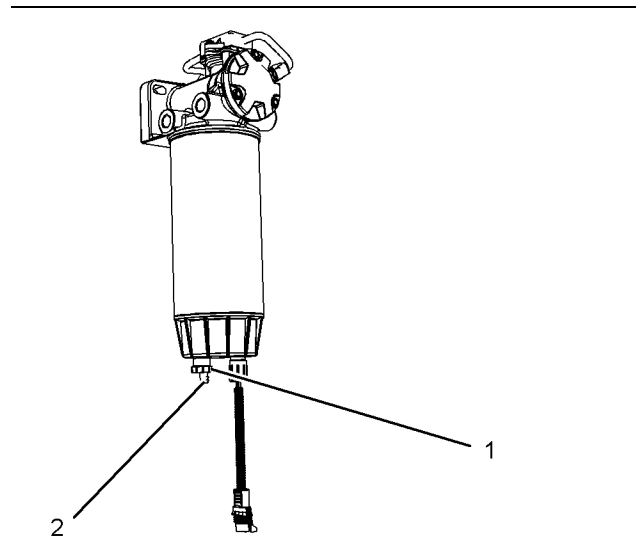

Illustration 67

g03352638

Typical example

1. Place a suitable container under the water separator in order to catch fluid to be drained.
2. Install a suitable tube onto connection (2).
3. Open drain valve (1) and allow the fluid to drain from filter.
4. When clean fuel can be seen to drain, tighten the drain valve securely, by hand pressure only.
5. Remove the tube. and dispose of any fluid in accordance with local regulations. Ensure that the filter is dry before engine operation.
6. If necessary, prime the fuel system, refer to this Operation and Maintenance Manual, "Fuel System - Prime".

i05269459

Fuel System Secondary Filter - Replace

WARNING

Fuel leaked or spilled onto hot surfaces or electrical components can cause a fire. To help prevent possible injury, turn the start switch off when changing fuel filters or water separator elements. Clean up fuel spills immediately.

Note: Refer to Systems Operation, Testing and Adjusting, “Cleanliness of Fuel System Components” for detailed information on the standards of cleanliness that must be observed during ALL work on the fuel system.

NOTICE

Ensure that the engine is stopped before any servicing or repair is performed.

NOTICE

Do not allow dirt to enter the fuel system. Thoroughly clean the area around a fuel system component that will be disconnected. Fit a suitable cover over disconnected fuel system component.

NOTICE

The low-pressure fuel system can be pressurized for a time period after the engine has stopped operating. The operating pressure of the low-pressure fuel system can be 500 kPa (73 psi).

Note: Both fuel filter elements must be replaced.

Remove the Element

1. Ensure that the fuel supply valve (if equipped) is in the OFF position. Place a suitable container under the fuel filters in order to catch any fuel that might spill. Clean up any spilled fuel.

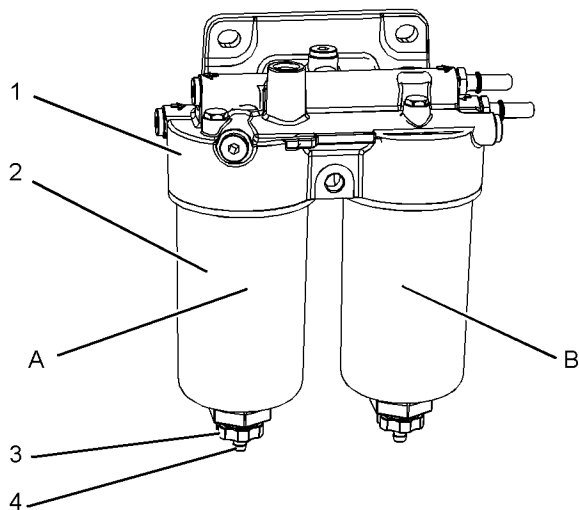

Illustration 68

g03353094

Typical example

2. Install a suitable tube onto connection (4). Rotate the drain valve (3) counterclockwise. Two full turns are required.
3. Allow the fuel to drain into the container and remove the tube.
4. Remove the filter bowl (2) from filter body (1). Rotate the filter bowl counterclockwise in order to remove the assembly.

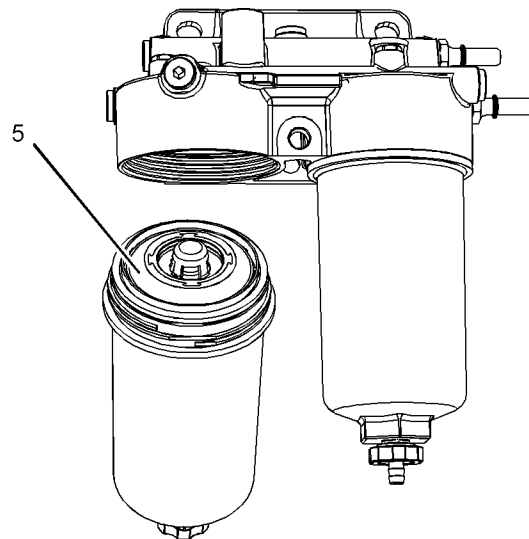

Illustration 69

g03353105

Typical example

- Rotate the filter element (5) counterclockwise and remove the filter element. Clean the filter bowl.

Install the Element

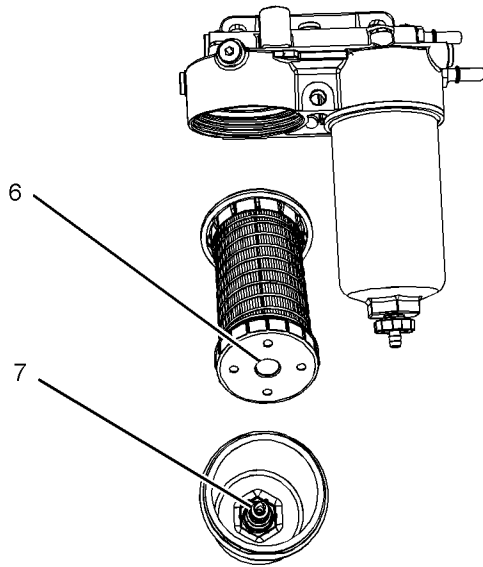

Illustration 70

g03353115

Typical example

- Locate the thread (7) in the filter element onto the threads (6). Spin on the new filter element and tighten the drain valve (3) by hand.
- Lubricate the seal on the filter element (5) with clean engine oil. Do NOT fill the filter bowl (2) with fuel before the filter assembly is installed.
- Do not use a tool in order to install the filter assembly. Tighten the assembly by hand. Install the filter bowl (2). Turn the filter bowl clockwise until the filter bowl locks into position against the stops.
- Filter assembly (A) is now complete. Perform the same procedure on filter assembly (B).
- When both filter elements have been replaced with new filter elements the fuel system can be primed, if the primary filter has also been renewed. If necessary, turn the fuel supply valve to the ON position.

- Prime the fuel system. Refer to the Operation and Maintenance Manual, "Fuel System - Prime" for more information.

i02348492

Fuel Tank Water and Sediment - Drain

NOTICE

Care must be taken to ensure that fluids are contained during performance of inspection, maintenance, testing, adjusting and repair of the product. Be prepared to collect the fluid with suitable containers before opening any compartment or disassembling any component containing fluids.

Dispose of all fluids according to local regulations and mandates.

Fuel Tank

Fuel quality is critical to the performance and to the service life of the engine. Water in the fuel can cause excessive wear to the fuel system.

Water can be introduced into the fuel tank when the fuel tank is being filled.

Condensation occurs during the heating and cooling of fuel. The condensation occurs as the fuel passes through the fuel system and the fuel returns to the fuel tank. This causes water to accumulate in fuel tanks. Draining the fuel tank regularly and obtaining fuel from reliable sources can help to eliminate water in the fuel.

Drain the Water and the Sediment

Fuel tanks should contain some provision for draining water and draining sediment from the bottom of the fuel tanks.

Open the drain valve on the bottom of the fuel tank in order to drain the water and the sediment. Close the drain valve.

Check the fuel daily. Allow five minutes after the fuel tank has been filled before draining water and sediment from the fuel tank.

Fill the fuel tank after operating the engine in order to drive out moist air. This will help prevent condensation. Do not fill the tank to the top. The fuel expands as the fuel gets warm. The tank may overflow.

Some fuel tanks use supply pipes that allow water and sediment to settle below the end of the fuel supply pipe. Some fuel tanks use supply lines that take fuel directly from the bottom of the tank. If the engine is equipped with this system, regular maintenance of the fuel system filter is important.

Fuel Storage Tanks

Drain the water and the sediment from the fuel storage tank at the following intervals:

- Weekly
- Service intervals
- Refill of the tank

This will help prevent water or sediment from being pumped from the storage tank into the engine fuel tank.

If a bulk storage tank has been refilled or moved recently, allow adequate time for the sediment to settle before filling the engine fuel tank. Internal baffles in the bulk storage tank will also help trap sediment. Filtering fuel that is pumped from the storage tank helps to ensure the quality of the fuel. When possible, water separators should be used.

i07819616

Hoses and Clamps - Inspect/Replace

WARNING

Contact with high pressure fuel may cause fluid penetration and burn hazards. High pressure fuel spray may cause a fire hazard. Failure to follow these inspection, maintenance and service instructions may cause personal injury or death.

If you inspect the engine in operation, always use the proper inspection procedure to avoid a fluid penetration hazard. Refer to Operation and Maintenance Manual, "General hazard Information" and Operation and Maintenance Manual, "High Pressure Fuel Lines" for the correct procedures.

Inspect all hoses for leaks that are caused by the following conditions:

- Cracking
- Softness
- Loose clamps

Replace hoses that are cracked or soft. Tighten any loose clamps.

Check for the following conditions:

- End fittings that are damaged or leaking
- Outer covering that is chafed or cut
- Exposed wire that is used for reinforcement
- Outer covering that is ballooning locally
- Flexible part of the hose that is kinked or crushed
- Armoring that is embedded in the outer covering

A constant torque hose clamp can be used in place of any standard hose clamp. Ensure that the constant torque hose clamp is the same size as the standard clamp.

Due to extreme temperature changes, the hose will harden. Hardening of the hoses will cause hose clamps to loosen. This can result in leaks. A constant torque hose clamp will help to prevent loose hose clamps.

Each installation application can be different. The differences depend on the following factors:

- Type of hose
- Type of fitting material
- Anticipated expansion and contraction of the hose
- Anticipated expansion and contraction of the fittings

Replace the Hoses and the Clamps

Refer to the OEM information for further information on removing and replacing fuel hoses (if equipped).

The following text describes a typical method of replacing coolant hoses. Refer to the OEM information for further information on the coolant system and the hoses for the coolant system.

WARNING

Pressurized System: Hot coolant can cause serious burns. To open the cooling system filler cap, stop the engine and wait until the cooling system components are cool. Loosen the cooling system pressure cap slowly in order to relieve the pressure.

1. Stop the engine. Allow the engine to cool.
2. Loosen the cooling system filler cap slowly to relieve any pressure. Remove the cooling system filler cap.

Note: Drain the coolant into a suitable, clean container. The coolant can be reused.

3. Drain the coolant from the cooling system to a level that is below the hose that is being replaced.
 4. Remove the hose clamps.
 5. Disconnect the old hose.
 6. Replace the old hose with a new hose.
 7. Install the hose clamps with a torque wrench.
- Note:** For the correct coolant, see this Operation and Maintenance Manual, "Fluid Recommendations".
8. Refill the cooling system. Refer to the OEM information for further information on refilling the cooling system.
 9. Clean the cooling system filler cap. Inspect the cooling system filler cap's seals. Replace the cooling system filler cap if the seals are damaged. Install the cooling system filler cap.
 10. Start the engine. Inspect the cooling system for leaks.

i08254039

Radiator - Clean

Note: Adjust the frequency of cleaning according to the effects of the operating environment.

Inspect the radiator for these items: damaged fins, corrosion, dirt, grease, insects, leaves, oil, and other debris. Clean the radiator, if necessary.

WARNING

Personal injury can result from air pressure.

Personal injury can result without following proper procedure. When using pressure air, wear a protective face shield and protective clothing.

The maximum air pressure for cleaning purposes must be reduced to 205 kPa (30 psi) when the air nozzle is deadheaded.

Pressurized air is the preferred method for removing loose debris. Direct the air in the opposite direction of the air flow. Hold the nozzle approximately 6 mm (0.25 inch) away from the fins. Slowly move the air nozzle in a direction that is parallel with the tubes. This movement will remove debris that is between the tubes.

Pressurized water may also be used for cleaning. The maximum water pressure for cleaning purposes must be less than 275 kPa (40 psi). Use pressurized water to soften mud. Clean the core from both sides.

Use a degreaser and steam for removal of oil and grease. Clean both sides of the core. Wash the core with detergent and hot water. Thoroughly rinse the core with clean water.

After cleaning, start the engine and bring the engine to high idle. This procedure will help in the removal of debris and drying of the core. Stop the engine. Use a light bulb behind the core to inspect the core for cleanliness. Repeat the cleaning, if necessary.

Inspect the fins for damage. Bent fins may be opened with a "comb". Inspect these items for good condition: welds, mounting brackets, air lines, connections, clamps, and seals. Make repairs, if necessary.

i07888480

Starting Motor - Inspect

Perkins recommends a scheduled inspection of the starting motor. If the starting motor fails, the engine may not start in an emergency situation.

Check the starting motor for correct operation. Check the electrical connections and clean the electrical connections. Refer to the Systems Operation, Testing and Adjusting Manual, "Electric Starting System - Test" for more information on the checking procedure and for specifications consult your Perkins dealer or your Perkins distributor for assistance.

i04144491

Turbocharger - Inspect

A regular visual inspection of the turbocharger is recommended. If the turbocharger fails during engine operation, damage to the turbocharger compressor wheel and/or to the engine may occur. Damage to the turbocharger compressor wheel can cause additional damage to the pistons, the valves, and the cylinder head.

NOTICE

Turbocharger bearing failures can cause large quantities of oil to enter the air intake and exhaust systems. Loss of engine lubricant can result in serious engine damage.

Minor leakage of oil into a turbocharger under extended low idle operation should not cause problems as long as a turbocharger bearing failure has not occurred.

When a turbocharger bearing failure is accompanied by a significant engine performance loss (exhaust smoke or engine rpm up at no load), do not continue engine operation until the turbocharger is renewed.

A visual inspection of the turbocharger can minimize unscheduled downtime. A visual inspection of the turbocharger can also reduce the chance for potential damage to other engine parts.

Removal and Installation

For options regarding the removal, installation, and replacement, consult your Carerpillar dealer. Refer to the Disassembly and Assembly, "Turbocharger - Remove and Turbocharger - Install" and Systems Operation, Testing and Adjusting, "Turbocharger - Inspect" for further information.

Inspecting

NOTICE

The compressor housing for the turbocharger must not be removed from the turbocharger for inspection or removed for the cleaning of the compressor.

1. Remove the pipe from the turbocharger exhaust outlet and remove the air intake pipe to the turbocharger. Visually inspect the piping for the presence of oil. Clean the interior of the pipes in order to prevent dirt from entering during reassembly.
2. Check for obvious heat discoloration of the turbocharger. Check for any loose bolts or any missing bolts. Check for damage to the oil supply line and the oil drain line. Check for cracks in the housing of the turbocharger. Ensure that the compressor wheel can rotate freely.
3. Check for the presence of oil. If oil is leaking from the back side of the compressor wheel, there is a possibility of a failed turbocharger oil seal.

The presence of oil may be the result of extended engine operation at low idle. The presence of oil may also be the result of a restriction of the line for the intake air (clogged air filters), which causes the turbocharger to slobber.

4. Inspect the bore of the housing of the turbine outlet for corrosion.

5. Fasten the air intake pipe and the exhaust outlet pipe to the turbocharger housing. Ensure that all clamps are installed correctly and that all clamps are tightened securely.

i02678854

Walk-Around Inspection

Inspect the Engine for Leaks and for Loose Connections

A walk-around inspection should only take a few minutes. When the time is taken to perform these checks, costly repairs and accidents can be avoided.

For maximum engine service life, make a thorough inspection of the engine compartment before starting the engine. Look for items such as oil leaks or coolant leaks, loose bolts, worn belts, loose connections and trash buildup. Make repairs, as needed:

- The guards must be in the correct place. Repair damaged guards or replace missing guards.
- Wipe all caps and plugs before the engine is serviced in order to reduce the chance of system contamination.

NOTICE

For any type of leak (coolant, lube, or fuel) clean up the fluid. If leaking is observed, find the source and correct the leak. If leaking is suspected, check the fluid levels more often than recommended until the leak is found or fixed, or until the suspicion of a leak is proved to be unwarranted.

NOTICE

Accumulated grease and/or oil on an engine is a fire hazard. Remove the accumulated grease and oil. Refer to this Operation and Maintenance Manual, "Engine - Clean" for more information.

- Ensure that the cooling system hoses are correctly clamped and that the cooling system hoses are tight. Check for leaks. Check the condition of all pipes.
- Inspect the water pump for coolant leaks.

Note: The water pump seal is lubricated by the coolant in the cooling system. It is normal for a small amount of leakage to occur as the engine cools down and the parts contract.

Maintenance Section
Water Pump - Inspect

Excessive coolant leakage may indicate the need to replace the water pump seal. For the removal of the water pump and the installation of water pump and/or seal, refer to the Disassembly and Assembly Manual, "Water Pump - Remove and Install" for more information or consult your Perkins dealer or your Perkins distributor.

- Inspect the lubrication system for leaks at the front crankshaft seal, the rear crankshaft seal, the oil pan, the oil filters and the rocker cover.
- Inspect the fuel system for leaks. Look for loose fuel line clamps and/or tie-wraps.
- Inspect the piping for the air intake system and the elbows for cracks and for loose clamps. Ensure that hoses and tubes are not contacting other hoses, tubes, wiring harnesses, etc.
- Inspect the alternator belts and any accessory drive belts for cracks, breaks or other damage.

Belts for multiple groove pulleys must be replaced as matched sets. If only one belt is replaced, the belt will carry more load than the belts that are not replaced. The older belts are stretched. The additional load on the new belt could cause the belt to break.

- Drain the water and the sediment from the fuel tank on a daily basis in order to ensure that only clean fuel enters the fuel system.
- Inspect the wiring and the wiring harnesses for loose connections and for worn wires or frayed wires.
- Inspect the ground strap for a good connection and for good condition.
- Disconnect any battery chargers that are not protected against the current drain of the starting motor. Check the condition and the electrolyte level of the batteries, unless the engine is equipped with a maintenance free battery.
- Check the condition of the gauges. Replace any gauges that are cracked. Replace any gauge that can not be calibrated.

i05298898

Water Pump - Inspect

A failed water pump may cause severe engine overheating problems that could result in the following conditions:

- Cracks in the cylinder head
- A piston seizure
- Other potential damage to the engine

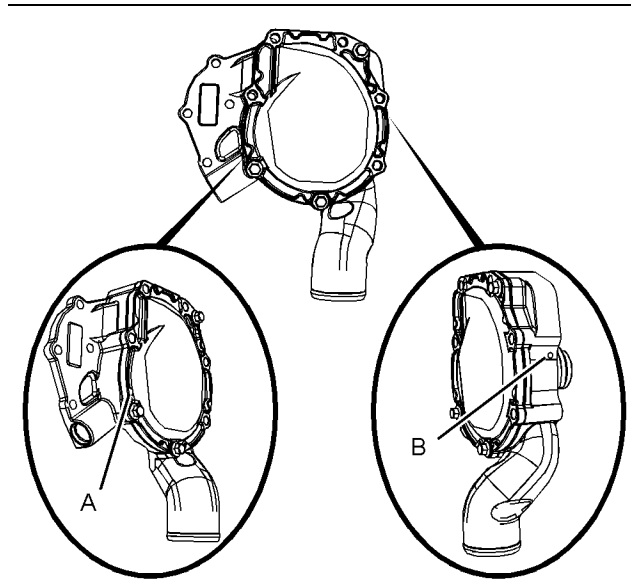

Illustration 71

g03364302

- (A) Weep hole
(B) Vent hole

Note: The water pump seals are lubricated by the coolant in the cooling system. A small amount of leakage will occur normally. Refer to illustration 71 for the position of the weep hole and the vent hole.

Visually inspect the water pump for leaks.

Note: If engine coolant enters the engine lubricating system, the lubricating oil and the engine oil filter must be replaced. This operation will remove any contamination that is caused by the coolant and this action will prevent any irregular oil samples.

The water pump is not a serviceable item. In order to install a new water pump, refer to the Disassembly and Assembly Manual, "Water Pump - Remove and Install".

Warranty Section

Warranty Information

i06590874

Emissions Warranty Information

This engine may be certified to comply with exhaust emission and gaseous emission standards that are prescribed by the law at the time of manufacture. This engine may be covered by an Emissions Warranty. Consult your authorized Perkins dealer or distributor to determine if your engine is emissions certified and if your engine is subject to an Emissions Warranty.

Reference Information Section

www.perkins.com

NOTICE
Dependant upon engine type and application.

Reference Materials

i04224089

Engine Protection Plans (Extended Service Contract)

Extended Service Contracts-purchased in minutes,
protected for years.

Extended Service Contracts (ESC) protect you from the stress that unexpected repair work brings to your life by covering the cost of getting your engine up and running again. Unlike other extended warranties, Perkins Platinum ESC protects you against all component part failures.

Purchase peace of mind from only £0.03 / \$0.05 / euro 0.04 a day and let an ESC make your dreams a reality.

Why buy an Extended Service Contract?

1. No surprises - total protection from unexpected repair cost (parts, labor, and travel).
2. Enjoy longer lasting product support from Perkins global network.
3. Genuine Perkins parts ensure continued engine performance.
4. Highly trained technicians carry out all repairs.
5. Transferable coverage should you sell your machine.

Flexible coverage provides the right level of protection for your Perkins Engine. Coverage can be extended to 2 years/ 1,000 hours right up to 10 year/ 40,000

You can buy an ESC at any time during standard warranty - even the last day!

Each Perkins Distributor has highly trained and experienced Perkins Product Support Service Technicians. The Support Service are equipped, and available around the clock to get your engine running again with the minimum of downtime. Buying an ESC means that you get all this for free.

To purchase an Extended Service Contract, is quick and simple! Contact your local Perkins Distributor now and the distributor can provide you with a quote in minutes. You can locate your nearest Perkins Distributor by visiting:

Index

A

After Starting Engine	51
After Stopping Engine	58
Aftercooler Core - Clean/Test (Air-To-Air Aftercooler)	77
Aftercooler Core - Inspect	77
Alarms and Shutoffs	31
Alarms	31
Shutoffs	31
Testing	31
Alternator - Inspect	77
Alternator and Fan Belts - Replace	77

B

Battery - Replace	78
Battery Electrolyte Level - Check	78
Battery or Battery Cable - Disconnect	79
Before Starting Engine	17, 49
Belt - Inspect	80
Belt Tensioner - Check	79
Burn Prevention	12
Batteries	13
Coolant	12
Oils	13

C

Cold Weather Operation	54
Hints for Cold Weather Operation	54
Idling the Engine	55
Recommendations for Coolant Warm Up....	55
Recommendations for the Coolant	55
Viscosity of the Engine Lubrication Oil	55
Cold Weather Starting	49
Configuration Parameters	45
Customer Specified Parameters	46
System Configuration Parameters	45
Coolant (Commercial Heavy-Duty) - Change	80
Drain	80
Fill	81
Flush	81
Coolant (ELC) - Change	82
Drain	83
Fill	83
Flush	83
Coolant Level - Check	84

Cooling System Supplemental Coolant Additive (SCA) - Test/Add	85
Add the SCA, If Necessary	85
Test for SCA Concentration	85
Crushing Prevention and Cutting Prevention..	14

D

Diagnostic Flash Code Retrieval	42
“Diagnostic” Lamp	42
Diagnostic Lamp	42
Driven Equipment - Check	85

E

Electrical System	18
Grounding Practices	18
Emergency Stopping	58
Emergency Stop Button	58
Emissions Certification Film	27
Emissions Warranty Information	107
Engine - Clean	86
Engine Air Cleaner Element (Dual Element/ Canister Type) - Clean/Replace (If Equipped)	86
Cleaning the Primary Air Cleaner Elements	87
Servicing the Air Cleaner Elements	86
Engine Air Cleaner Element (Single Element) - Inspect/Replace	89
Engine Air Cleaner Service Indicator - Inspect	89
Test the Service Indicator	90
Engine Air Precleaner - Check/Clean	90
Engine Crankcase Breather Element - Replace	90
Engine Diagnostics	42
Engine Electronics	19
Engine Mounts - Inspect	91
Engine Oil and Filter - Change	92
Drain the Engine Lubricating Oil	92
Fill the Oil Pan	94
Replace the Oil Filter	93
Engine Oil Level - Check	91
Engine Oil Sample - Obtain	92
Obtain the Sample and the Analysis	92
Engine Operation	53
Engine Operation with Active Diagnostic Codes	44

Engine Operation with Intermittent Diagnostic Codes	45	Fuel System Secondary Filter - Replace	100
Engine Protection Plans (Extended Service Contract)	108	Install the Element	102
Engine Starting	17, 49	Remove the Element	101
Engine Stopping	18, 58	Fuel Tank Water and Sediment - Drain	102
Engine Valve Lash - Check	95	Drain the Water and the Sediment	102
		Fuel Storage Tanks	103
		Fuel Tank	102
F		G	
Fan Clearance - Check	95	Gauges and Indicators	32
Fault Logging	44	Indicator Lamps	32
Features and Controls	31	Instrument panels and Displays	33
Fire Prevention and Explosion Prevention	13	General Hazard Information	8
Fire Extinguisher	14	Containing Fluid Spillage	10
Lines, Tubes, and Hoses	14	Dispose of Waste Properly	12
Fluid Recommendations	66	Fluid Penetration	9
ELC Cooling System Maintenance	68	Inhalation	10
General Coolant Information	66	Pressure Air and Water	9
Fluid Recommendations (Engine Oil Specification)	70	Static Electricity Hazard when Fueling with Ultra-low Sulfur Diesel Fuel	10
Engine Oil	70	General Information	20
General Lubricant Information	70		
Fluid Recommendations (Fuel Specification)	60	H	
Diesel Fuel Characteristics	62	High Pressure Fuel Lines	15
Diesel Fuel Requirements	60	Hoses and Clamps - Inspect/Replace	103
General Information	60	Replace the Hoses and the Clamps	103
Service Intervals for Biodiesel and High sulfur Fuels	65		
Foreword	4	I	
California Proposition 65 Warning	4	Important Safety Information	2
Literature Information	4		
Maintenance	4	L	
Maintenance Intervals	5	Lifting and Storage	29
Operation	4		
Overhaul	5	M	
Safety	4	Maintenance Interval Schedule	75
Fuel and the Effect from Cold Weather	56	Commissioning	76
Fuel Conservation Practices	53	Daily	75
Fuel Related Components in Cold Weather ..	57	Every 1000 Service Hours	75
Fuel Filters	57	Every 2000 Service Hours	75
Fuel Heaters	57	Every 3000 Service Hours	76
Fuel Tanks	57	Every 3000 Service Hours or 2 Years	76
Fuel System - Prime	96	Every 400 Service Hours	75
Electric Prime	97	Every 4000 Service Hours	76
Hand Fuel Priming Pump	97	Every 50 Service Hours or Weekly	75
Fuel System Primary Filter (Water Separator) Element - Replace	99	Every 500 Service Hours	75
Fuel System Primary Filter/Water Separator - Drain	100	Every 500 Service Hours or 1 Year	75
		Every 6000 Service Hours or 3 Years	76
		Every Week	75

Initial 500 Service Hours.....	75	Safety Section	6
When Required.....	75	Self-Diagnostics	42
Maintenance Recommendations	73	Sensors and Electrical Components.....	35
Maintenance Section.....	60	Severe Service Application	74
Model View Illustrations	20	Environmental Factors.....	74
Off Engine Parts and Options.....	24	Incorrect Maintenance Procedures	74
Turbocharge Engine View	23	Incorrect Operating Procedures	74
Turbocharged Aftercooled Engine.....	20	Starting Motor - Inspect.....	104
Monitoring System.....	33–34	Starting the Engine.....	50
Programmable Options and Systems		Constant Speed Engines.....	50
Operation	34	Starting the Engine	50
Mounting and Dismounting	15	Starting with Jump Start Cables (Do Not	
		Use This Procedure in Hazardous	
		Locations that have Explosive	
		Atmospheres)	50
		Stopping the Engine	58
O			
Operation Section.....	29	T	
Overspeed.....	35	Table of Contents	3
		Turbocharger - Inspect.....	104
		Inspecting	105
		Removal and Installation	105
		W	
P		Walk-Around Inspection	105
Plate Locations and Film Locations	27	Inspect the Engine for Leaks and for Loose	
Serial Number Plate (1).....	27	Connections.....	105
Product Description.....	24	Warranty Information.....	107
Electronic Engine Features	25	Warranty Section.....	107
Engine Cooling and Lubrication	25	Water Pump - Inspect.....	106
Engine Diagnostics.....	25	Welding on Engines with Electronic	
Engine Specifications	24	Controls	73
Option Section	26		
Product Identification Information	27		
Product Information Section.....	20		
Product Lifting	29		
Product Storage	29		
Condition for Storage.....	29		
R			
Radiator - Clean	104		
Reference Information.....	28		
Record for Reference	28		
Reference Information Section	108		
Reference Materials	108		
Refill Capacities.....	60		
Coolant	60		
Fuel.....	60		
Lubricating Oil.....	60		
S			
Safety Messages.....	6		
(1) Universal Warning	6		
2 Hand (High Pressure).....	7		
Ether	7		

Product and Dealer Information

Note: For product identification plate locations, see the section "Product Identification Information" in the Operation and Maintenance Manual.

Delivery Date: _____

Product Information

Model: _____

Product Identification Number: _____

Engine Serial Number: _____

Transmission Serial Number: _____

Generator Serial Number: _____

Attachment Serial Numbers: _____

Attachment Information: _____

Customer Equipment Number: _____

Dealer Equipment Number: _____

Dealer Information

Name: _____ Branch: _____

Address: _____

Dealer Contact

Phone Number

Hours

Sales: _____

Parts: _____

Service: _____

SEBU9066
©2020 Perkins Engines Company Limited
All Rights Reserved