

Operation and Maintenance Manual

1104D Engine

NH (Engine)

NJ (Engine)



Important Safety Information

Most accidents that involve product operation, maintenance and repair are caused by failure to observe basic safety rules or precautions. An accident can often be avoided by recognizing potentially hazardous situations before an accident occurs. A person must be alert to potential hazards. This person should also have the necessary training, skills and tools to perform these functions correctly.

Incorrect operation, lubrication, maintenance or repair of this product can be dangerous and could result in injury or death.

Do not operate or perform any lubrication, maintenance or repair on this product, until you have read and understood the operation, lubrication, maintenance and repair information.

Safety precautions and warnings are provided in this manual and on the product. If these hazard warnings are not heeded, bodily injury or death could occur to you or to other persons.

The hazards are identified by the "Safety Alert Symbol" and followed by a "Signal Word" such as "DANGER", "WARNING" or "CAUTION". The Safety Alert "WARNING" label is shown below.



The meaning of this safety alert symbol is as follows:

Attention! Become Alert! Your Safety is Involved.

The message that appears under the warning explains the hazard and can be either written or pictorially presented.

Operations that may cause product damage are identified by "NOTICE" labels on the product and in this publication.

Perkins cannot anticipate every possible circumstance that might involve a potential hazard. The warnings in this publication and on the product are, therefore, not all inclusive. You must not use this product in any manner different from that considered by this manual without first satisfying yourself that you have considered all safety rules and precautions applicable to the operation of the product in the location of use, including site-specific rules and precautions applicable to the worksite. If a tool, procedure, work method or operating technique that is not specifically recommended by Perkins is used, you must satisfy yourself that it is safe for you and for others. You should also ensure that you are authorized to perform this work, and that the product will not be damaged or become unsafe by the operation, lubrication, maintenance or repair procedures that you intend to use.

The information, specifications, and illustrations in this publication are on the basis of information that was available at the time that the publication was written. The specifications, torques, pressures, measurements, adjustments, illustrations, and other items can change at any time. These changes can affect the service that is given to the product. Obtain the complete and most current information before you start any job. Perkins dealers or Perkins distributors have the most current information available.



When replacement parts are required for this product Perkins recommends using Perkins replacement parts.

Failure to heed this warning can lead to premature failures, product damage, personal injury or death.

In the United States, the maintenance, replacement, or repair of the emission control devices and systems may be performed by any repair establishment or individual of the owner's choosing.

Table of Contents

Foreword	4
----------------	---

Safety Section

Safety Messages	6
-----------------------	---

General Hazard Information	9
----------------------------------	---

Burn Prevention	12
-----------------------	----

Fire Prevention and Explosion Prevention	13
--	----

Crushing Prevention and Cutting Prevention ..	15
---	----

Mounting and Dismounting	15
--------------------------------	----

High Pressure Fuel Lines	15
--------------------------------	----

Before Starting Engine	17
------------------------------	----

Engine Starting	17
-----------------------	----

Engine Stopping	18
-----------------------	----

Electrical System	18
-------------------------	----

Engine Electronics	19
--------------------------	----

Product Information Section

Model Views	20
-------------------	----

Product Identification Information	25
--	----

Operation Section

Lifting and Storage	27
---------------------------	----

Gauges and Indicators	30
-----------------------------	----

Features and Controls	31
-----------------------------	----

Engine Diagnostics	38
--------------------------	----

Engine Starting	42
-----------------------	----

Engine Operation	44
------------------------	----

Engine Stopping	45
-----------------------	----

Cold Weather Operation	47
------------------------------	----

Maintenance Section

Refill Capacities	51
-------------------------	----

Maintenance Recommendations	67
-----------------------------------	----

Maintenance Interval Schedule	69
-------------------------------------	----

Warranty Section

Warranty Information	106
----------------------------	-----

Index Section

Index	107
-------------	-----

Foreword

California Proposition 65 Warning

Diesel engine exhaust and some of its constituents are known to the State of California to cause cancer, birth defects, and other reproductive harm.



WARNING – This product can expose you to chemicals including ethylene glycol, which is known to the State of California to cause birth defects or other reproductive harm. For more information go to:

www.P65Warnings.ca.gov

Do not ingest this chemical. Wash hands after handling to avoid incidental ingestion.



WARNING – This product can expose you to chemicals including lead and lead compounds, which are known to the State of California to cause cancer, birth defects, or other reproductive harm. For more information go to:

www.P65Warnings.ca.gov

Wash hands after handling components that may contain lead.

Literature Information

This manual contains safety, operation instructions, lubrication, and maintenance information. This manual should be stored in or near the engine area in a literature holder or literature storage area. Read, study, and keep the manual with the literature and engine information.

English is the primary language for all Perkins publications. The English used facilitates translation and consistency.

Some photographs or illustrations in this manual show details or attachments that may be different from your engine. Guards and covers may have been removed for illustrative purposes. Continuing improvement and advancement of product design may have caused changes to your engine which are not included in this manual. Whenever a question arises regarding your engine, or this manual, please consult with your Perkins dealer or your Perkins distributor for the latest available information.

Safety

This safety section lists basic safety precautions. In addition, this section identifies hazardous, warning situations. Read and understand the basic precautions listed in the safety section before operating or performing lubrication, maintenance, and repair on this product.

Operation

Operating techniques outlined in this manual are basic. The operating techniques assist with developing the skills and techniques required to operate the engine more efficiently and economically. Skill and techniques develop as the operator gains knowledge of the engine and the capabilities of the engine.

The operation section is a reference for operators. Photographs and illustrations guide the operator through procedures of inspecting, starting, operating, and stopping the engine. This section also includes a discussion of electronic diagnostic information.

Maintenance

The maintenance section is a guide to engine care. The illustrated, step-by-step instructions are grouped by service hours and/or calendar time maintenance intervals. Items in the maintenance schedule are referenced to detailed instructions that follow.

Recommended service should be performed at the appropriate intervals as indicated in the Maintenance Interval Schedule. The actual operating environment of the engine also governs the Maintenance Interval Schedule. Therefore, under severe, dusty, wet, or freezing cold operating conditions, more frequent lubrication, and maintenance than is specified in the Maintenance Interval Schedule may be necessary.

The maintenance schedule items are organized for a preventive maintenance management program. If the preventive maintenance program is followed, a periodic tune-up is not required. The implementation of a preventive maintenance management program should minimize operating costs through cost avoidances resulting from reductions in unscheduled downtime and failures.

Maintenance Intervals

Perform maintenance on items at multiples of the original requirement. Each level and/or individual items in each level should be shifted ahead or back depending upon your specific maintenance practices, operation, and application. Perkins recommends that the maintenance schedules be reproduced and displayed near the engine as a convenient reminder. Perkins also recommends that a maintenance record be maintained as part of the permanent record of the engine.

Your authorized Perkins dealer or your Perkins distributor can assist you in adjusting your maintenance schedule to meet the needs of your operating environment.

Overhaul

Major engine overhaul details are not covered in the Operation and Maintenance Manual except for the interval and the maintenance items in that interval. Major repairs are best left to trained personnel or an authorized Perkins distributor or dealer. Your Perkins dealer or your Perkins distributor offers various options regarding overhaul programs. If you experience a major engine failure, there are also numerous after failure overhaul options available. Consult with your Perkins dealer or your Perkins distributor for information regarding these options.

Safety Section

i02864025

Safety Messages

There may be several specific warning signs on your engine. The exact location and a description of the warning signs are reviewed in this section. Please become familiar with all warning signs.

Ensure that all of the warning signs are legible. Clean the warning signs or replace the warning signs if the words cannot be read or if the illustrations are not visible. Use a cloth, water, and soap to clean the warning signs. Do not use solvents, gasoline, or other harsh chemicals. Solvents, gasoline, or harsh chemicals could loosen the adhesive that secures the warning signs. The warning signs that are loosened could drop off of the engine.

Replace any warning sign that is damaged or missing. If a warning sign is attached to a part of the engine that is replaced, install a new warning sign on the replacement part. Your Perkins dealer or your distributor can provide new warning signs.

(1) Universal Warning



Do not operate or work on this equipment unless you have read and understand the instructions and warnings in the Operation and Maintenance Manuals. Failure to follow the instructions or heed the warnings could result in serious injury or death.

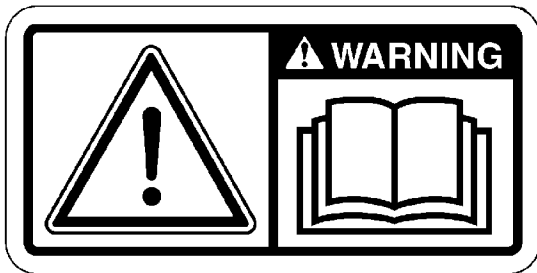

Illustration 1

g01154807

Typical example

The Universal Warning label (1) is located on both sides of the valve mechanism cover base. Refer to illustration 1 .

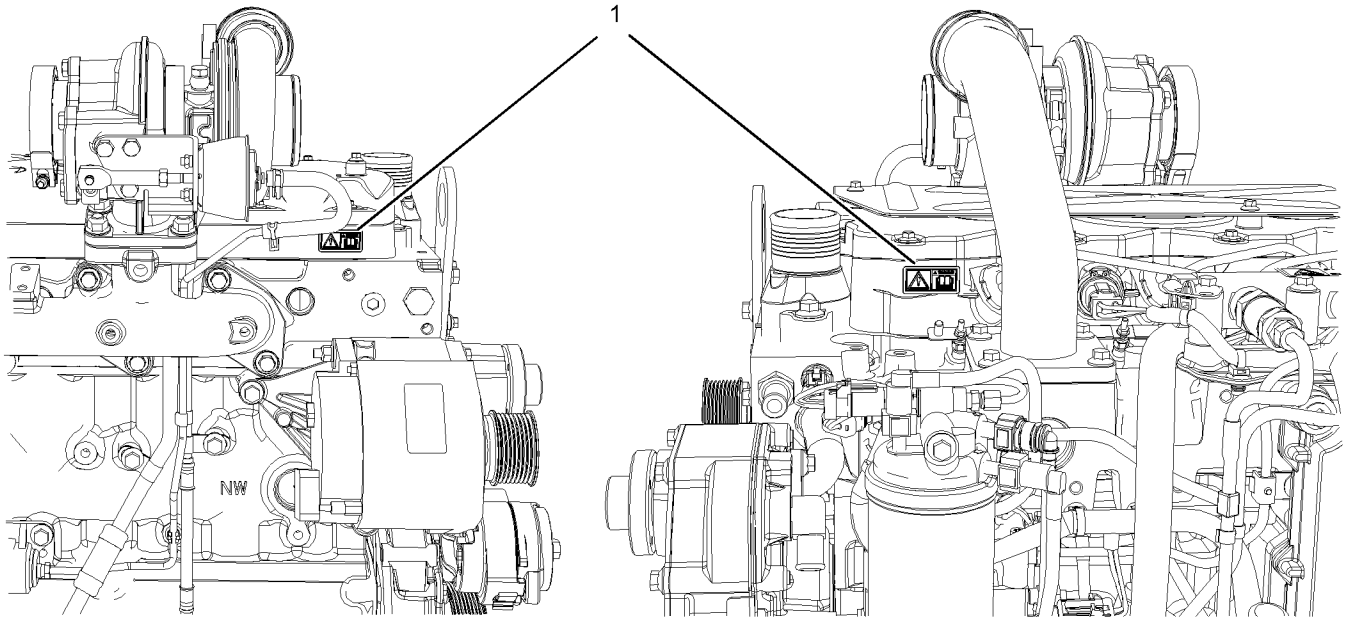

Illustration 2

g01268960

(1) Universal warning

(2) Hand (High Pressure)**⚠ WARNING**

Contact with high pressure fuel may cause fluid penetration and burn hazards. High pressure fuel spray may cause a fire hazard. Failure to follow these inspection, maintenance and service instructions may cause personal injury or death.

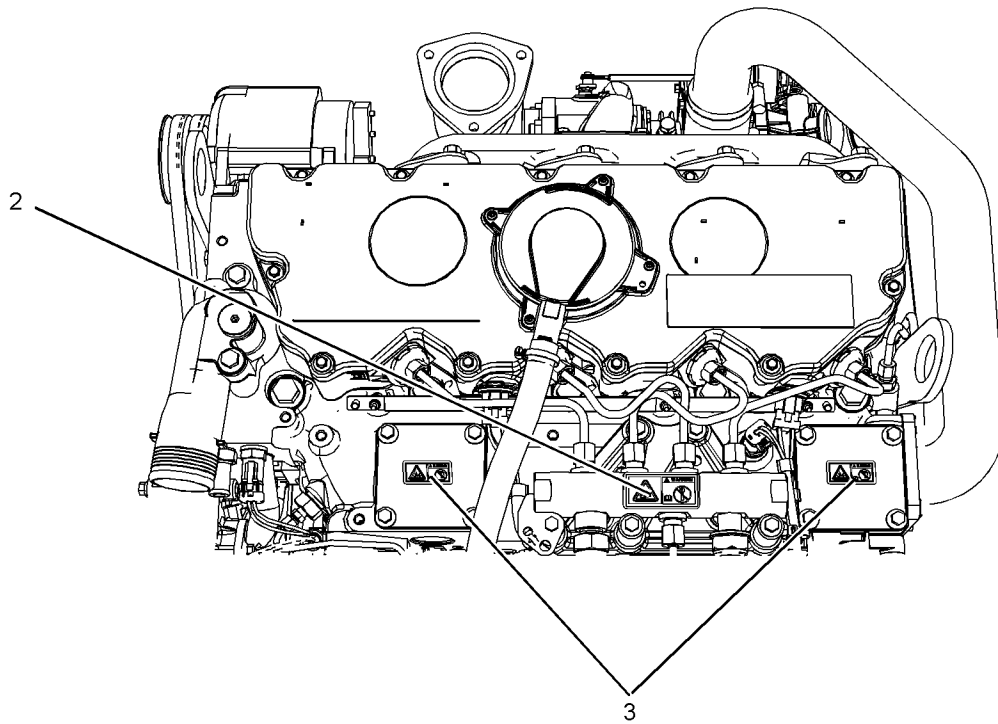

Illustration 3

g01426636

(2) Hand (High Pressure)

(3) Ether

The warning label for the Hand (High Pressure) (2) is located on the top of the fuel manifold. Refer to illustration 4 .



Illustration 4

g01154858

Typical example

(3) Ether

⚠ WARNING
Do not use aerosol types of starting aids such as ether. Such use could result in an explosion and personal injury.



Illustration 5

g01154809

Typical example

The ether warning label (3) is located on the cover of the inlet manifold. Refer to illustration 4 .

Note: The location of this label will depend on the application of the engine.

i08312758

General Hazard Information

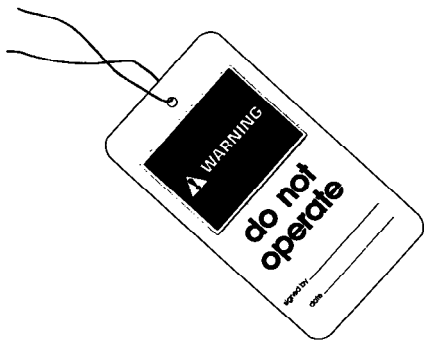

Illustration 6

g00104545

Attach a “Do Not Operate” warning tag or a similar warning tag to the start switch or to the controls before you service the equipment or before you repair the equipment.

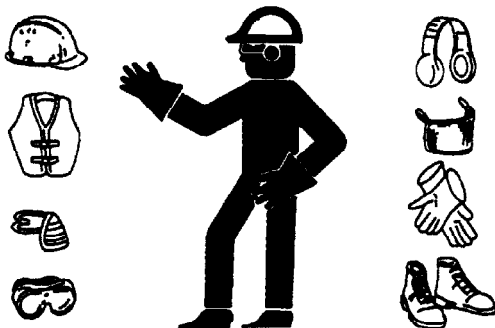

Illustration 7

g00702020

Wear a hard hat, protective glasses, and other protective equipment, as required.

Do not wear loose clothing or jewelry that can snag on controls or on other parts of the engine.

Make sure that all protective guards and all covers are secured in place on the engine.

Keep the engine free from foreign material. Remove debris, oil, tools, and other items from the deck, from walkways, and from steps.

Never put maintenance fluids into glass containers. Drain all liquids into a suitable container.

Obey all local regulations for the disposal of liquids.

Use all cleaning solutions with care.

Report all necessary repairs.

Do not allow unauthorized personnel on the equipment.

Disconnect the batteries when maintenance is performed or when the electrical system is serviced. Disconnect the battery ground leads. Tape the leads to help prevent sparks. If equipped, allow the diesel exhaust fluid to be purged before disconnecting the battery.

Perform maintenance on the engine with the equipment in the servicing position. Refer to the OEM information for the procedure for placing the equipment in the servicing position.

Do not attempt any repairs that are not understood. Use the proper tools. Replace any equipment that is damaged or repair the equipment.

For initial start-up of a new engine or for starting an engine that has been serviced, make provisions to stop the engine if an overspeed occurs. The stopping of the engine may be accomplished by shutting off the fuel supply and/or the air supply to the engine. Ensure that only the fuel supply line is shut off. Ensure that the fuel return line is open.

Start the engine from the operators station (cab). Never short across the starting motor terminals or the batteries. This action could bypass the engine neutral start system and/or the electrical system could be damaged.

Engine exhaust contains products of combustion which may be harmful to your health. Always start the engine and operate the engine in a ventilated area. If the engine is in an enclosed area, vent the engine exhaust to the outside.

Use caution when cover plates are removed. Gradually loosen, but do not remove the last two bolts or nuts that are located at opposite ends of the cover plate or the device. Before removing the last two bolts or nuts, pry the cover loose to relieve any spring pressure or other pressure.

Pressure Air and Water

Pressurized air and/or water can cause debris and/or hot water to be blown out. This action could result in personal injury.

The direct application of pressurized air or pressurized water to the body could result in personal injury.

Safety Section
General Hazard Information

When pressurized air and/or water is used for cleaning, wear protective clothing, protective shoes, and eye protection. Eye protection includes goggles or a protective face shield.

The maximum air pressure for cleaning purposes must be below 205 kPa (30 psi). The maximum water pressure for cleaning purposes must be below 275 kPa (40 psi).

Fluid Penetration

Pressure can be trapped in the hydraulic circuit long after the engine has been stopped. The pressure can cause hydraulic fluid or items such as pipe plugs to escape rapidly if the pressure is not relieved correctly.

Do not remove any hydraulic components or parts until pressure has been relieved or personal injury may occur. Do not disassemble any hydraulic components or parts until pressure has been relieved or personal injury may occur. Refer to the OEM information for any procedures that are required to relieve the hydraulic pressure.

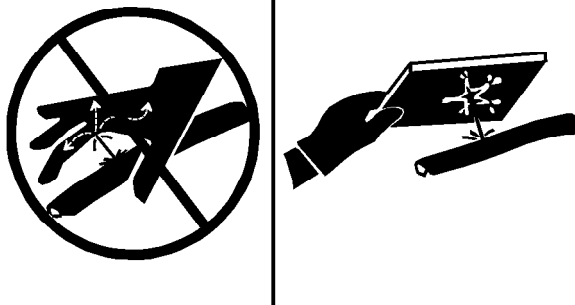

Illustration 8

g00687600

Always use a board or cardboard when you check for a leak. Leaking fluid that is under pressure can penetrate body tissue. Fluid penetration can cause serious injury and possible death. A pin hole leak can cause severe injury. If fluid is injected into your skin, you must get treatment immediately. Seek treatment from a doctor that is familiar with this type of injury.

Containing Fluid Spillage

Care must be taken to ensure that fluids are contained during performance of inspection, maintenance, testing, adjusting, and repair of the engine. Make provision to collect the fluid with a suitable container before any compartment is opened or before any component is disassembled.

- Only use the tools that are suitable for collecting fluids and equipment that is suitable for collecting fluids.

- Only use the tools that are suitable for containing fluids and equipment that is suitable for containing fluids.

Obey all local regulations for the disposal of liquids.

Static Electricity Hazard when Fueling with Ultra-low Sulfur Diesel Fuel

The removal of sulfur and other compounds in ultra-low sulfur diesel fuel (ULSD fuel) decreases the conductivity of ULSD and increases the ability of ULSD to store static charge. Refineries may have treated the fuel with a static dissipating additive. Many factors can reduce the effectiveness of the additive over time. Static charges can build up in ULSD fuel while the fuel is flowing through fuel delivery systems. Static electricity discharge when combustible vapors are present could result in a fire or explosion. Ensure that the entire system used to refuel your machine (fuel supply tank, transfer pump, transfer hose, nozzle, and others) is properly grounded and bonded. Consult with your fuel or fuel system supplier to ensure that the delivery system complies with fueling standards for proper grounding and bonding.

⚠ WARNING

Avoid static electricity risk when fueling. Ultra-low sulfur diesel fuel (ULSD fuel) poses a greater static ignition hazard than earlier diesel formulations with a higher sulfur contents. Avoid death or serious injury from fire or explosion. Consult with your fuel or fuel system supplier to ensure the delivery system is in compliance with fueling standards for proper grounding and bonding practices.

Inhalation

Illustration 9

g00702022

Exhaust

Use caution. Exhaust fumes can be hazardous to health. If you operate the equipment in an enclosed area, adequate ventilation is necessary.

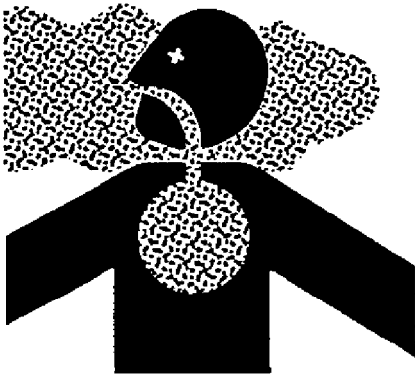
Hexavalent Chromium

Perkins equipment and replacement parts comply with applicable regulations and requirements where originally sold. Perkins recommends the use of only genuine Perkins replacement parts.

Hexavalent chromium has occasionally been detected on exhaust and heat shield systems on Perkins engines. Although laboratory testing is the only accurate way to know if hexavalent chromium is, in fact, present, the presence of a yellow deposit in areas of high heat (for example, exhaust system components or exhaust insulation) may be an indication of the presence of hexavalent chromium.

Use caution if you suspect the presence of hexavalent chromium. Avoid skin contact when handling items that you suspect may contain hexavalent chromium, and avoid inhalation of any dust in the suspect area. Inhalation of, or skin contact with, hexavalent chromium dust may be hazardous to your health.

If such yellow deposits are found on the engine, engine component parts, or associated equipment or packages, Perkins recommends following local health and safety regulations and guidelines, utilizing good hygiene, and adhering to safe work practices when handling the equipment or parts. Perkins also recommends the following:

- Wear appropriate Personal Protective Equipment (PPE)
- Wash your hands and face with soap and water prior to eating, drinking, or smoking, and also during rest room breaks, to prevent ingestion of any yellow powder
- Never use compressed air for cleaning areas suspected of containing hexavalent chromium
- Avoid brushing, grinding, or cutting materials suspected of containing hexavalent chromium
- Obey environmental regulations for the disposal of all materials that may contain or have come into contact with hexavalent chromium
- Stay away from areas that might have hexavalent chromium particles in the air.

Asbestos Information

Perkins equipment and replacement parts that are shipped from Perkins engine company limited are asbestos free. Perkins recommends the use of only genuine Perkins replacement parts. Use the following guidelines when you handle any replacement parts that contain asbestos or when you handle asbestos debris.

Use caution. Avoid inhaling dust that might be generated when you handle components that contain asbestos fibers. Inhaling this dust can be hazardous to your health. The components that may contain asbestos fibers are brake pads, brake bands, lining material, clutch plates, and some gaskets. The asbestos that is used in these components is usually bound in a resin or sealed in some way. Normal handling is not hazardous unless airborne dust that contains asbestos is generated.

If dust that may contain asbestos is present, there are several guidelines that should be followed:

- Never use compressed air for cleaning.
- Avoid brushing materials that contain asbestos.
- Avoid grinding materials that contain asbestos.
- Use a wet method to clean up asbestos materials.
- A vacuum cleaner that is equipped with a high efficiency particulate air filter (HEPA) can also be used.

- Use exhaust ventilation on permanent machining jobs.
- Wear an approved respirator if there is no other way to control the dust.
- Comply with applicable rules and regulations for the work place. In the United States, use Occupational Safety and Health Administration (OSHA) requirements. These OSHA requirements can be found in “29 CFR 1910.1001”.
- Obey environmental regulations for the disposal of asbestos.
- Stay away from areas that might have asbestos particles in the air.

Dispose of Waste Properly

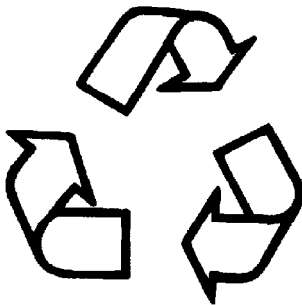

Illustration 10

g00706404

Improperly disposing of waste can threaten the environment. Potentially harmful fluids should be disposed of in accordance with local regulations.

Always use leakproof containers when you drain fluids. Do not pour waste onto the ground, down a drain, or into any source of water.

i07118164

Burn Prevention

Do not touch any part of an operating engine. Allow the engine to cool before any maintenance is performed on the engine.

WARNING

Contact with high pressure fuel may cause fluid penetration and burn hazards. High pressure fuel spray may cause a fire hazard. Failure to follow these inspection, maintenance and service instructions may cause personal injury or death.

After the engine has stopped, you must wait for 60 seconds to allow the fuel pressure to be purged from the high-pressure fuel lines before any service or repair is performed on the engine fuel lines.

Allow the pressure to be purged in the air system, in the hydraulic system, in the lubrication system, or in the cooling system before any lines, fittings, or related items are disconnected.

Coolant

When the engine is at operating temperature, the engine coolant is hot. The coolant is also under pressure. The radiator and all lines to the heaters or to the engine contain hot coolant.

Any contact with hot coolant or with steam can cause severe burns. Allow cooling system components to cool before the cooling system is drained.

Check that the coolant level after the engine has stopped and the engine has been allowed to cool.

Ensure that the filler cap is cool before removing the filler cap. The filler cap must be cool enough to touch with a bare hand. Remove the filler cap slowly to relieve pressure.

Cooling system conditioner contains alkali. Alkali can cause personal injury. Do not allow alkali to contact the skin, the eyes, or the mouth.

Oils

Hot oil and hot lubricating components can cause personal injury. Do not allow hot oil to contact the skin. Also, do not allow hot components to contact the skin.

Diesel Fuel

Diesel may be irritating to the eyes, respiratory system, and skin. Prolonged exposure to diesel may cause various skin conditions. Appropriate personal protective equipment should be used. Refer to supplier Material safety Data sheets for detailed information.

Viton Seals

WARNING

If Viton is burned, a product of this burnt material is an acid which is hazardous. Do not allow burnt material to come into contact with the skin or with the eyes. Use the appropriate set of Personal Protective Equipment to protect your skin and eyes. Failure to follow the instructions or heed the warning could result in serious injury or death.

If there is need to come into contact with components which have been burnt, ensure that the precautions which follow are used:

- Ensure that the components have cooled.
- Use Neoprene gloves and discard the gloves safely after use.
- Wash the area with calcium hydroxide solution and then with clean water.
- Disposal of components and gloves which are contaminated must be in accordance with local regulations.

If there is contamination of the skin or eyes, wash the affected area with a continuous supply of clean water or with calcium hydroxide solution. Wash the area effected for 15 to 60 minutes and obtain immediate medical attention.

Batteries

Electrolyte is an acid. Electrolyte can cause personal injury. Do not allow electrolyte to contact the skin or the eyes. Always wear protective glasses for servicing batteries. Wash hands after touching the batteries and connectors. Use of gloves is recommended.

i04823662

Fire Prevention and Explosion Prevention



Illustration 11

g00704000

All fuels, most lubricants, and some coolant mixtures are flammable.

Flammable fluids that are leaking or spilled onto hot surfaces or onto electrical components can cause a fire. Fire may cause personal injury and property damage.

After the emergency stop button is operated, ensure that you allow 15 minutes, before the engine covers are removed.

Determine whether the engine will be operated in an environment that allows combustible gases to be drawn into the air inlet system. These gases could cause the engine to overspeed. Personal injury, property damage, or engine damage could result.

If the application involves the presence of combustible gases, consult your Perkins dealer and/or your Perkins distributor for additional information about suitable protection devices.

Remove all flammable combustible materials or conductive materials such as fuel, oil, and debris from the engine. Do not allow any flammable combustible materials or conductive materials to accumulate on the engine.

Store fuels and lubricants in correctly marked containers away from unauthorized persons. Store oily rags and any flammable materials in protective containers. Do not smoke in areas that are used for storing flammable materials.

Do not expose the engine to any flame.

Exhaust shields (if equipped) protect hot exhaust components from oil or fuel spray in a line, a tube, or a seal failure. Exhaust shields must be installed correctly.

Do not weld on lines or tanks that contain flammable fluids. Do not flame cut lines or tanks that contain flammable fluid. Clean any such lines or tanks thoroughly with a nonflammable solvent prior to welding or flame cutting.

Wiring must be kept in good condition. Ensure that all electrical wires are correctly routed and securely attached. Check all electrical wires daily. Repair any wires that are loose or frayed before you operate the engine. Clean all electrical connections and tighten all electrical connections.

Eliminate all wiring that is unattached or unnecessary. Do not use any wires or cables that are smaller than the recommended gauge. Do not bypass any fuses and/or circuit breakers.

Arcing or sparking could cause a fire. Secure connections, recommended wiring, and correctly maintained battery cables will help to prevent arcing or sparking.

WARNING

Contact with high pressure fuel may cause fluid penetration and burn hazards. High pressure fuel spray may cause a fire hazard. Failure to follow these inspection, maintenance and service instructions may cause personal injury or death.

After the engine has stopped, wait for 60 seconds in order to allow the fuel pressure to be purged from the high-pressure fuel lines before any service or repair is performed on the engine fuel lines.

Safety Section
Fire Prevention and Explosion Prevention

Ensure that the engine is stopped. Inspect all lines and hoses for wear or for deterioration. Properly route all hoses. The lines and hoses must have adequate support and secure clamps.

Properly install oil filters and fuel filters. The filter housings must be tightened to the correct torque. Refer to the Disassembly and Assembly manual for more information.



Illustration 12

g00704059

Use caution when you are refueling an engine. Do not smoke while you are refueling an engine. Do not refuel an engine near open flames or sparks. Always stop the engine before refueling.

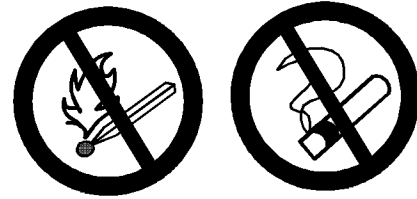

Illustration 13

g02298225

Gases from a battery can explode. Keep any open flames or sparks away from the top of a battery. Do not smoke in battery charging areas.

Never check the battery charge by placing a metal object across the terminal posts. Use a voltmeter or a hydrometer.

Incorrect jumper cable connections can cause an explosion that can result in injury. Refer to the Operation Section of this manual for specific instructions.

Do not charge a frozen battery. Charging a frozen battery may cause an explosion.

The batteries must be kept clean. The covers (if equipped) must be kept on the cells. Use the recommended cables, connections, and battery box covers when the engine is operated.

Fire Extinguisher

Make sure that a fire extinguisher is available. Be familiar with the operation of the fire extinguisher. Inspect the fire extinguisher and service the fire extinguisher regularly. Obey the recommendations on the instruction plate.

Lines, Tubes, and Hoses

Do not bend high-pressure lines. Do not strike high-pressure lines. Do not install any lines that are damaged.

Leaks can cause fires. Consult your Perkins dealer or your Perkins distributor for replacement parts.

Replace the parts if any of the following conditions are present:

- High-pressure fuel line or lines are removed.
- End fittings are damaged or leaking.
- Outer coverings are chafed or cut.
- Wires are exposed.
- Outer coverings are ballooning.
- Flexible parts of the hoses are kinked.
- Outer covers have embedded armoring.
- End fittings are displaced.

Make sure that all clamps, guards, and heat shields are installed correctly in order to prevent vibration, rubbing against other parts, and excessive heat.

i02143194

Crushing Prevention and Cutting Prevention

Support the component correctly when work beneath the component is performed.

Unless other maintenance instructions are provided, never attempt adjustments while the engine is running.

Stay clear of all rotating parts and of all moving parts. Leave the guards in place until maintenance is performed. After the maintenance is performed, reinstall the guards.

Keep objects away from moving fan blades. The fan blades will throw objects or cut objects.

When objects are struck, wear protective glasses in order to avoid injury to the eyes.

Chips or other debris may fly off objects when objects are struck. Before objects are struck, ensure that no one will be injured by flying debris.

i02235492

Mounting and Dismounting

Inspect the steps, the handholds, and the work area before mounting the engine. Keep these items clean and keep these items in good repair.

Mount the engine and dismount the engine only at locations that have steps and/or handholds. Do not climb on the engine, and do not jump off the engine.

Face the engine in order to mount the engine or dismount the engine. Maintain a three-point contact with the steps and handholds. Use two feet and one hand or use one foot and two hands. Do not use any controls as handholds.

Do not stand on components which cannot support your weight. Use an adequate ladder or use a work platform. Secure the climbing equipment so that the equipment will not move.

Do not carry tools or supplies when you mount the engine or when you dismount the engine. Use a hand line to raise and lower tools or supplies.

i02861106

High Pressure Fuel Lines

WARNING

Contact with high pressure fuel may cause fluid penetration and burn hazards. High pressure fuel spray may cause a fire hazard. Failure to follow these inspection, maintenance and service instructions may cause personal injury or death.

Safety Section
High Pressure Fuel Lines

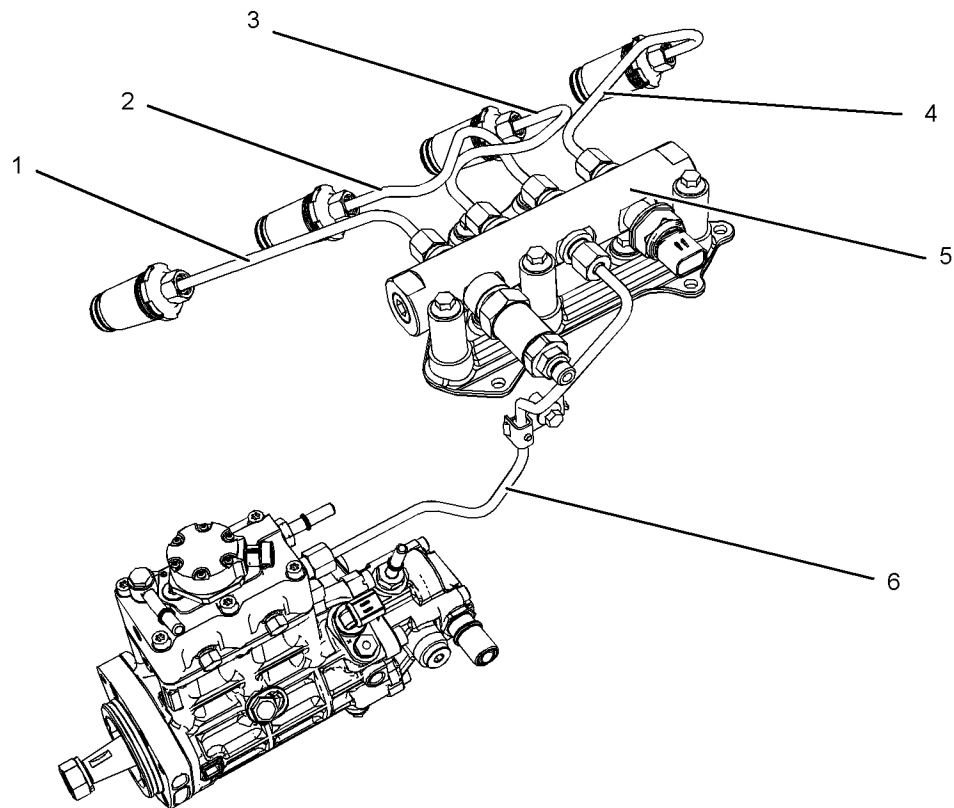

Illustration 14

g01425090

(1) High pressure line
(2) High pressure line

(3) High pressure line
(4) High pressure line

(5) High pressure fuel manifold (rail)
(6) High pressure line

The high pressure fuel lines are the fuel lines that are between the high pressure fuel pump and the high pressure fuel manifold and the fuel lines that are between the fuel manifold and cylinder head. These fuel lines are different from fuel lines on other fuel systems.

This is because of the following differences:

- The high pressure fuel lines are constantly charged with high pressure.
- The internal pressures of the high pressure fuel lines are higher than other types of fuel system.
- The high pressure fuel lines are formed to shape and then strengthened by a special process.

Do not step on the high pressure fuel lines. Do not deflect the high pressure fuel lines. Do not bend or strike the high pressure fuel lines. Deformation or damage of the high pressure fuel lines may cause a point of weakness and potential failure.

Do not check the high pressure fuel lines with the engine or the starting motor in operation. After the engine has stopped allow 60 seconds to pass in order to allow the pressure to be purged before any service or repair is performed on the engine fuel lines.

Do not loosen the high pressure fuel lines in order to remove air from the fuel system. This procedure is not required.

Visually inspect the high pressure fuel lines before the engine is started. This inspection should be each day.

If you inspect the engine in operation, always use the proper inspection procedure in order to avoid a fluid penetration hazard. Refer to Operation and Maintenance Manual, "General Hazard Information".

- Inspect the high pressure for the following: damage, deformation, a nick, a cut, a crease, or a dent

- Do not operate the engine with a fuel leak. If there is a leak do not tighten the connection in order to stop the leak. The connection must only be tightened to the recommended torque. Refer to Disassembly and Assembly Manual, “Fuel Injection Lines - Remove and Fuel Injection Lines - Install”.
- If the high pressure fuel lines are torqued correctly and the high pressure fuel lines are leaking the high pressure fuel lines must be replaced.
- Ensure that all clips on the high pressure fuel lines are in place. Do not operate the engine with clips that are damaged, missing or clips that are loose.
- Do not attach any other item to the high pressure fuel lines.
- Loosened high pressure fuel lines must be replaced. Also removed high pressure fuel lines must be replaced. Refer to Disassembly and Assembly Manual, “ Fuel Injection Lines - Install”.

i05874054

Before Starting Engine

NOTICE

For initial start-up of a new or rebuilt engine, and for start-up of an engine that has been serviced, make provision to shut the engine off should an overspeed occur. This may be accomplished by shutting off the air and/or fuel supply to the engine.

WARNING

Engine exhaust contains products of combustion which may be harmful to your health. Always start and operate the engine in a well ventilated area and, if in an enclosed area, vent the exhaust to the outside.

Inspect the engine for potential hazards.

Do not start the engine or move any of the controls if there is a “DO NOT OPERATE” warning tag or similar warning tag attached to the start switch or to the controls.

Before starting the engine, ensure that no one is on, underneath, or close to the engine. Ensure that the area is free of personnel.

If equipped, ensure that the lighting system for the engine is suitable for the conditions. Ensure that all lights work properly, if equipped.

All protective guards and all protective covers must be installed if the engine must be started in order to perform service procedures. To help prevent an accident that is caused by parts in rotation, work around the parts carefully.

Do not bypass the automatic shutoff circuits. Do not disable the automatic shutoff circuits. The circuits are provided in order to help prevent personal injury. The circuits are also provided in order to help prevent engine damage.

See the Service Manual for repairs and for adjustments.

i02251260

Engine Starting

WARNING

Do not use aerosol types of starting aids such as ether. Such use could result in an explosion and personal injury.

If a warning tag is attached to the engine start switch or to the controls DO NOT start the engine or move the controls. Consult with the person that attached the warning tag before the engine is started.

All protective guards and all protective covers must be installed if the engine must be started in order to perform service procedures. To help prevent an accident that is caused by parts in rotation, work around the parts carefully.

Start the engine from the operator's compartment or from the engine start switch.

Always start the engine according to the procedure that is described in the Operation and Maintenance Manual, “Engine Starting” topic in the Operation Section. Knowing the correct procedure will help to prevent major damage to the engine components. Knowing the procedure will also help to prevent personal injury.

To ensure that the jacket water heater (if equipped) and/or the lube oil heater (if equipped) is working correctly, check the water temperature gauge and/or the oil temperature gauge during the heater operation.

Engine exhaust contains products of combustion which can be harmful to your health. Always start the engine and operate the engine in a well ventilated area. If the engine is started in an enclosed area, vent the engine exhaust to the outside.

Note: The engine is equipped with a device for cold starting. If the engine will be operated in very cold conditions, then an extra cold starting aid may be required. Normally, the engine will be equipped with the correct type of starting aid for your region of operation.

These engines are equipped with a glow plug starting aid in each individual cylinder that heats the intake air in order to improve starting.

i02234873

Engine Stopping

Stop the engine according to the procedure in the Operation and Maintenance Manual, "Engine Stopping (Operation Section)" in order to avoid overheating of the engine and accelerated wear of the engine components.

Use the Emergency Stop Button (if equipped) **ONLY** in an emergency situation. Do not use the Emergency Stop Button for normal engine stopping. After an emergency stop, **DO NOT** start the engine until the problem that caused the emergency stop has been corrected.

Stop the engine if an overspeed condition occurs during the initial start-up of a new engine or an engine that has been overhauled.

To stop an electronically controlled engine, cut the power to the engine and/or shutting off the air supply to the engine.

i02234878

Electrical System

Never disconnect any charging unit circuit or battery circuit cable from the battery when the charging unit is operating. A spark can cause the combustible gases that are produced by some batteries to ignite.

To help prevent sparks from igniting combustible gases that are produced by some batteries, the negative "-" cable should be connected last from the external power source to the negative "-" terminal of the starting motor. If the starting motor is not equipped with a negative "-" terminal, connect the cable to the engine block.

Check the electrical wires daily for wires that are loose or frayed. Tighten all loose electrical connections before the engine is started. Repair all frayed electrical wires before the engine is started. See the Operation and Maintenance Manual for specific starting instructions.

Grounding Practices

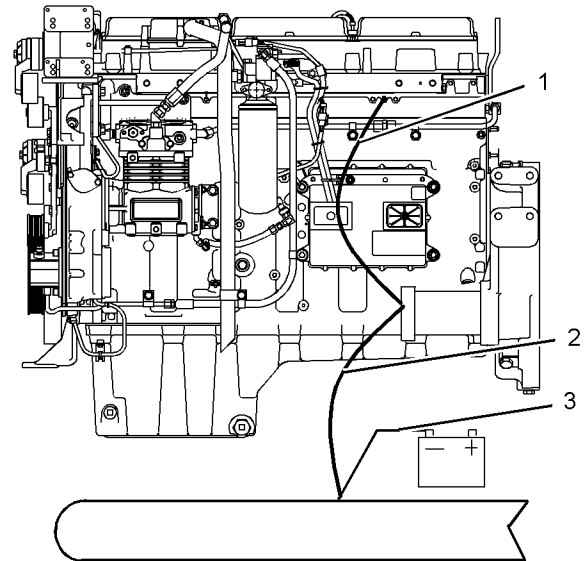

Illustration 15

g01162916

Typical example

- (1) Starting motor to engine block
- (2) Ground to starting motor
- (3) Ground to battery

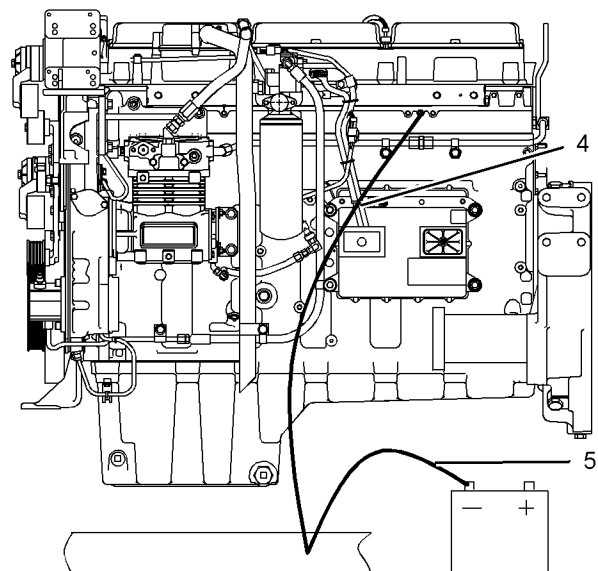

Illustration 16

g01162918

Typical example

- (4) Ground to engine
- (5) Ground to battery

Correct grounding for the engine electrical system is necessary for optimum engine performance and reliability. Incorrect grounding will result in uncontrolled electrical circuit paths and in unreliable electrical circuit paths.

Uncontrolled electrical circuit paths can result in damage to the crankshaft bearing journal surfaces and to aluminum components.

Engines that are installed without engine-to-frame ground straps can be damaged by electrical discharge.

To ensure that the engine and the engine electrical systems function correctly, an engine-to-frame ground strap with a direct path to the battery must be used. This path may be provided by way of a direct engine ground to the frame.

The connections for the grounds should be tight and free of corrosion. The engine alternator must be grounded to the negative “-” battery terminal with a wire that is adequate to handle the full charging current of the alternator.

The power supply connections and the ground connections for the engine electronics should always be from the isolator to the battery.

i02650954

The following monitored engine operating conditions have the ability to limit engine speed and/or the engine power:

- Engine Coolant Temperature
- Engine Oil Pressure
- Engine Speed/Timing
- Intake Manifold Air Temperature

The Engine Monitoring package can vary for different engine models and different engine applications. However, the monitoring system and the engine monitoring control will be similar for all engines.

Note: Many of the engine control systems and display modules that are available for Perkins Engines will work in unison with the Engine Monitoring System. Together, the two controls will provide the engine monitoring function for the specific engine application. Refer to Troubleshooting for more information on the Engine Monitoring System.

Engine Electronics

WARNING

Tampering with the electronic system installation or the OEM wiring installation can be dangerous and could result in personal injury or death and/or engine damage.

WARNING

Electrical Shock Hazard. The electronic unit injectors use DC voltage. The ECM sends this voltage to the electronic unit injectors. Do not come in contact with the harness connector for the electronic unit injectors while the engine is operating. Failure to follow this instruction could result in personal injury or death.

This engine has a comprehensive, programmable Engine Monitoring System. The Electronic Control Module (ECM) has the ability to monitor the engine operating conditions. If any of the engine parameters extend outside an allowable range, the ECM will initiate an immediate action.

The following actions are available for engine monitoring control:

- Warning
- Derate
- Shutdown

Product Information Section

Model Views

i02861104

Model View Illustrations

The following model views show typical features of the engine. Due to individual applications, your engine may appear different from the illustrations.

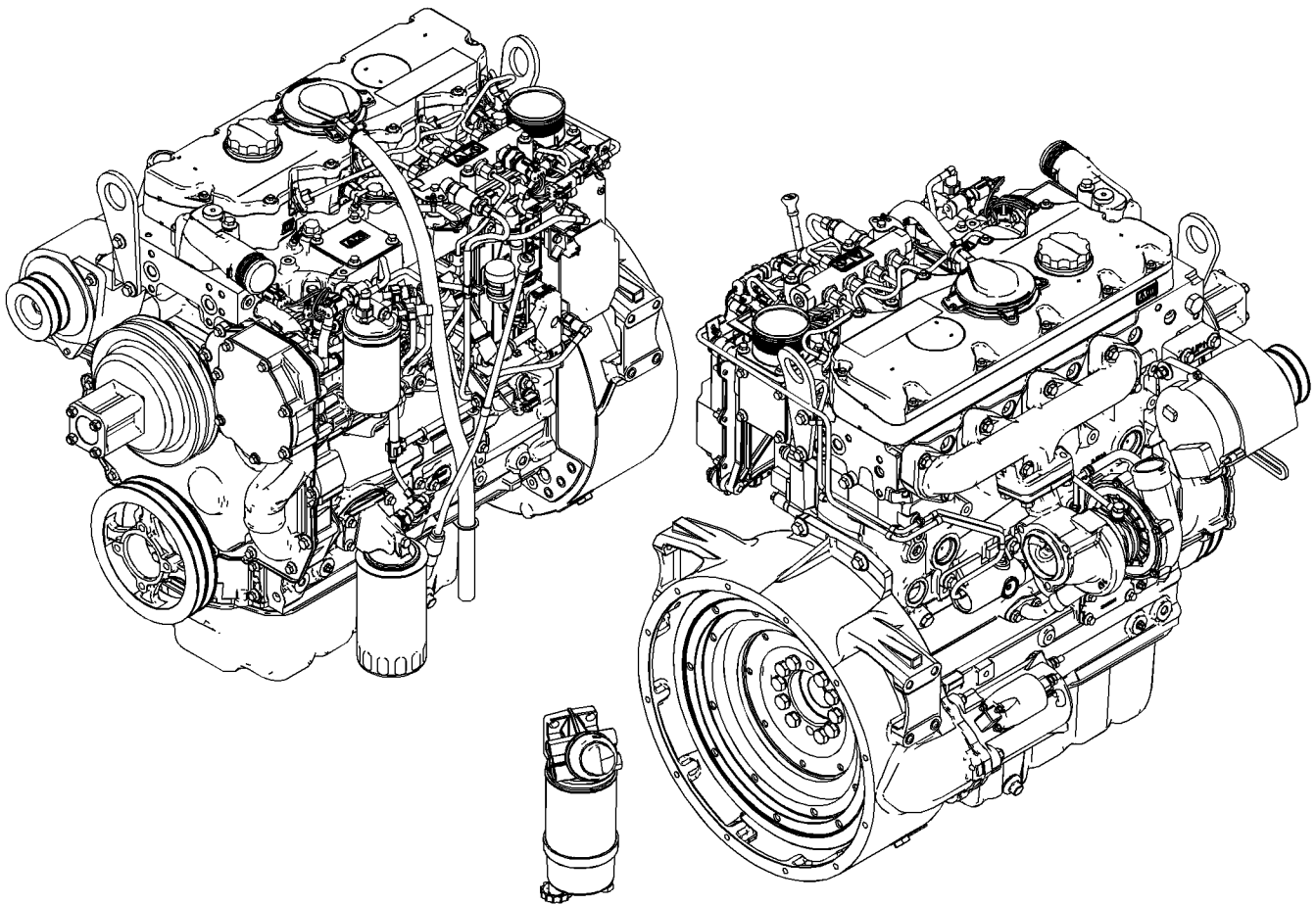

Illustration 17

The 1104D NJ engine is turbocharged and aftercooled.

g01425089

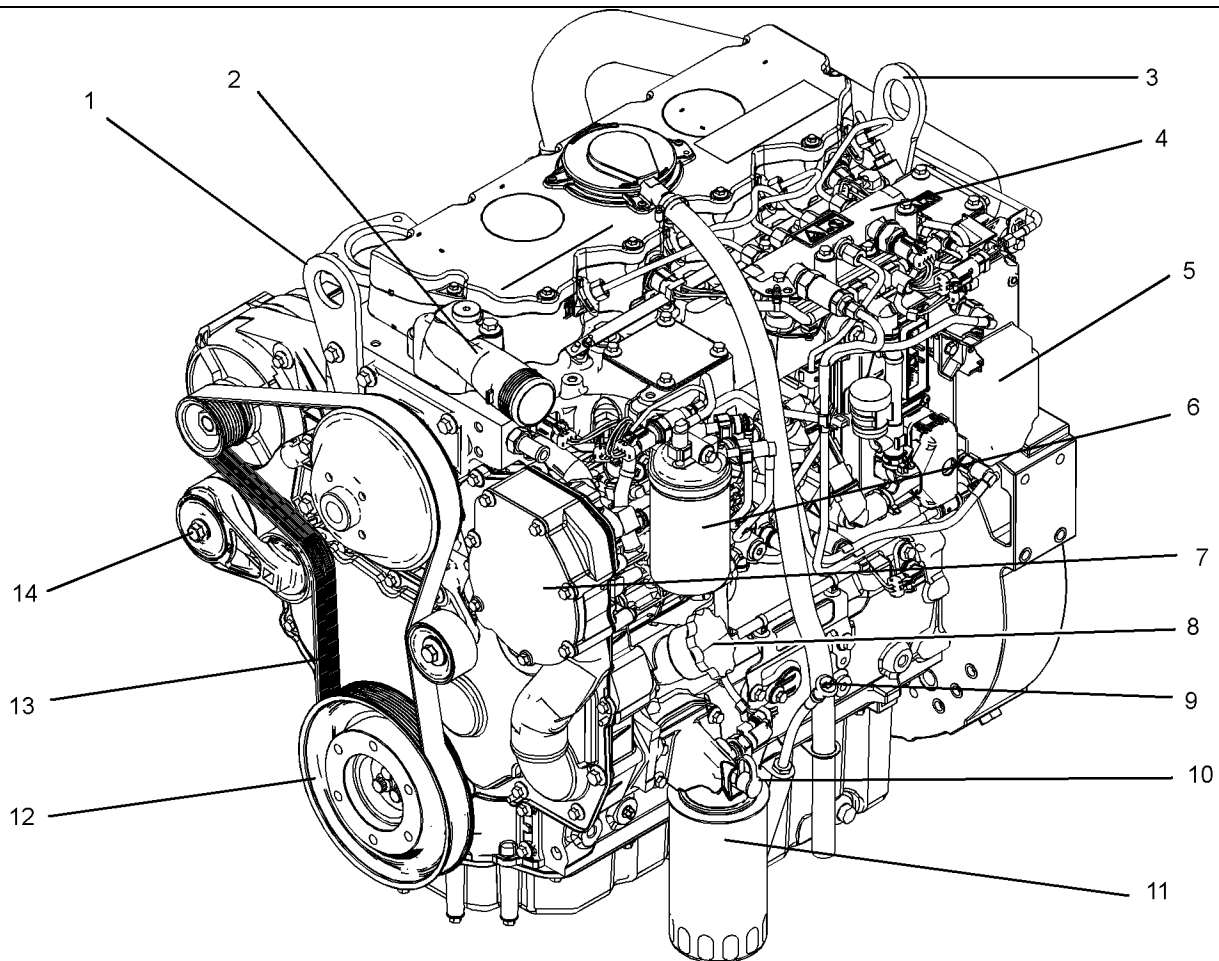

Illustration 18

g01428165

The 1104D NH engine is turbocharged.

Front left engine view

- | | | |
|-------------------------------|---------------------------|------------------------|
| (1) Front lifting eye | (6) Secondary fuel filter | (11) Oil filter |
| (2) Water outlet | (7) Water pump | (12) Crankshaft pulley |
| (3) Rear lifting eye | (8) Oil Filler | (13) Drive Belt |
| (4) Fuel manifold (rail) | (9) Oil gauge | (14) Belt tensioner |
| (5) Electronic control module | (10) Oil sampling valve | |

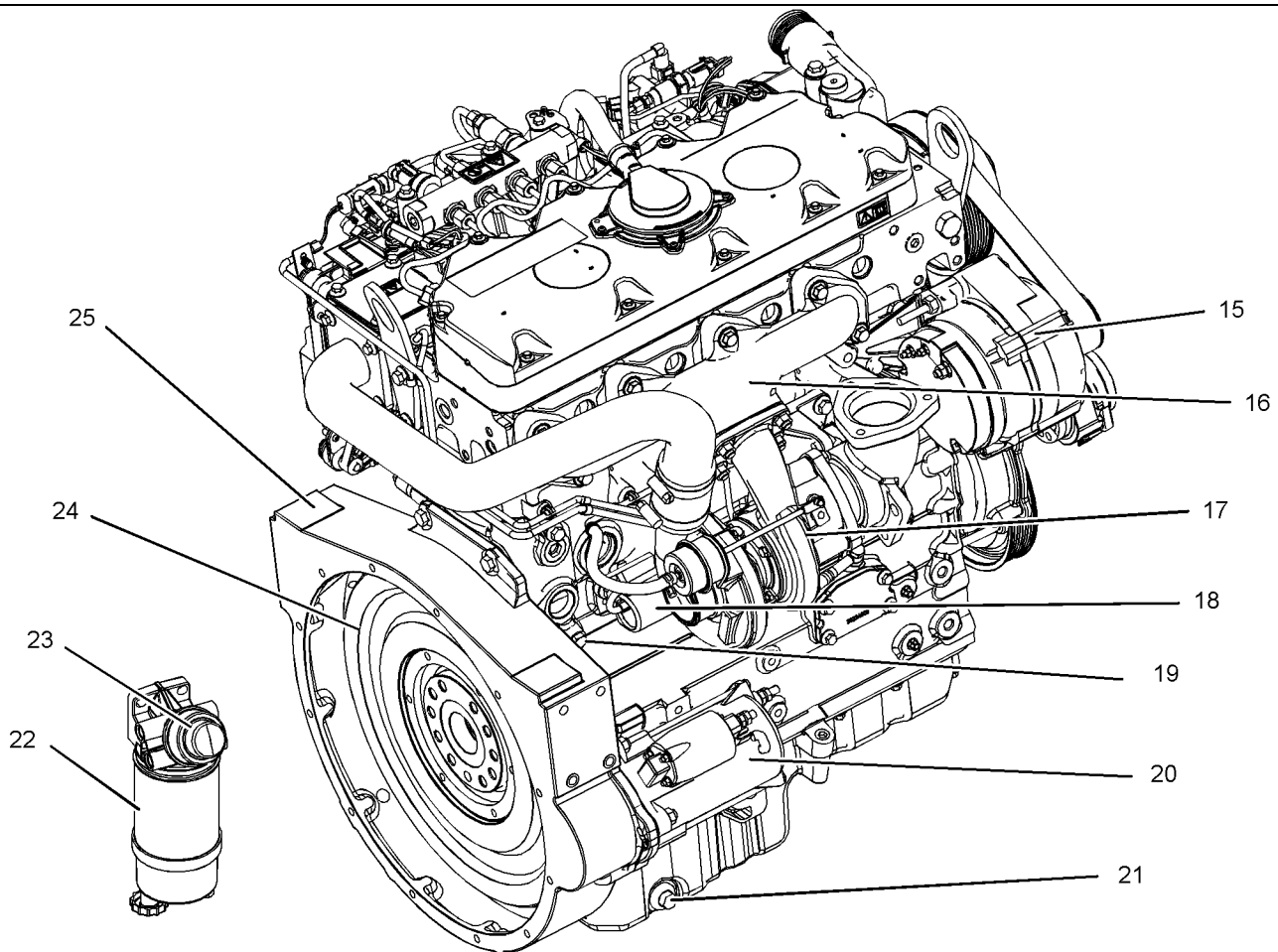

Illustration 19

g01428176

Rear right engine view

- | | | |
|-------------------------|---|-----------------------------|
| (15) Alternator | (19) Drain plug or coolant sampling valve | (23) Hand fuel priming pump |
| (16) Exhaust manifold | (20) Starting Motor | (24) Flywheel |
| (17) Turbocharger | (21) Oil drain plug | (25) Flywheel housing |
| (18) Wastegate solenoid | (22) Primary fuel filter | |

Note: The primary fuel filter may be mounted off the engine.

i04925801

Engine Description

The 1104 Electronic Engine models NH and NJ are designed for the following applications: machine and industrial mobile equipment. The engine is available in the following type of aspiration:

- Turbocharged
- Turbocharged aftercooled
- In-line 4 cylinder

Engine Specifications

Note: The front end of the engine is opposite the flywheel end of the engine. The left and the right sides of the engine are determined from the flywheel end. The number 1 cylinder is the front cylinder.

Emissions Control Systems

NH - Direct Diesel Injection, Turbocharger, and Engine Control Module

NJ - Direct Diesel Injection, Turbocharger with Air to Air Charge Cooler and Engine Control Module

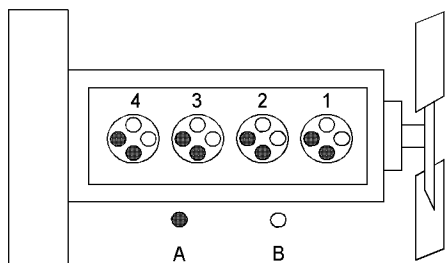

Illustration 20

g01187485

(A) Exhaust valves
(B) Inlet valves

Table 1

1104 Electronic Engine Specifications	
Operating Range (rpm)	750 to 2640 ⁽¹⁾
Number of Cylinders	4 In-Line
Bore	105 mm (4.13 inch)
Stroke	127 mm (5.0 inch)
Aspiration	NH Turbocharged engine NJ Turbocharged engine that is aftercooled
Compression Ratio	16.2:1
Displacement	4.4 L (269 in ³)
Firing Order	1,3,4,2
Rotation (flywheel end)	Counterclockwise
Valve Lash Setting (Inlet)	0.35 mm (0.013 inch)
Valve Lash Setting (Exhaust)	0.35 mm (0.013 inch)

⁽¹⁾ The operating rpm is dependent on the engine rating, the application, and the configuration of the throttle.

Electronic Engine Features

The engine operating conditions are monitored. The Electronic Control Module (ECM) controls the response of the engine to these conditions and to the demands of the operator. These conditions and operator demands determine the precise control of fuel injection by the ECM. The electronic engine control system provides the following features:

- Engine monitoring

- Engine speed governing
- Control of the injection pressure
- Cold start strategy
- Automatic air/fuel ratio control
- Torque rise shaping
- Injection timing control
- System diagnostics

For more information on electronic engine features, refer to the Operation and Maintenance Manual, "Features and Controls" topic (Operation Section).

Engine Diagnostics

The engine has built-in diagnostics in order to ensure that the engine systems are functioning correctly. The operator will be alerted to the condition by a "Stop or Warning" lamp. Under certain conditions, the engine horsepower and the vehicle speed may be limited. The electronic service tool may be used to display the diagnostic codes.

There are three types of diagnostic codes: active, logged and event.

Most of the diagnostic codes are logged and stored in the ECM. For additional information, refer to the Operation and Maintenance Manual, "Engine Diagnostics" topic (Operation Section).

The ECM provides an electronic governor that controls the injector output in order to maintain the desired engine rpm.

Engine Cooling and Lubrication

The cooling system consists of the following components:

- Gear-driven centrifugal water pump
- Water temperature regulator which regulates the engine coolant temperature
- Gear-driven rotor type oil pump
- Oil cooler

The engine lubricating oil is supplied by a rotor type oil pump. The engine lubricating oil is cooled and the engine lubricating oil is filtered. The bypass valves can provide unrestricted flow of lubrication oil to the engine if the oil filter element should become plugged.

Product Information Section
Engine Description

Engine efficiency, efficiency of emission controls, and engine performance depend on adherence to proper operation and maintenance recommendations. Engine performance and efficiency also depend on the use of recommended fuels, lubrication oils, and coolants. Refer to this Operation and Maintenance Manual, "Maintenance Interval Schedule" for more information on maintenance items.

Product Identification Information

i02378644

Plate Locations and Film Locations

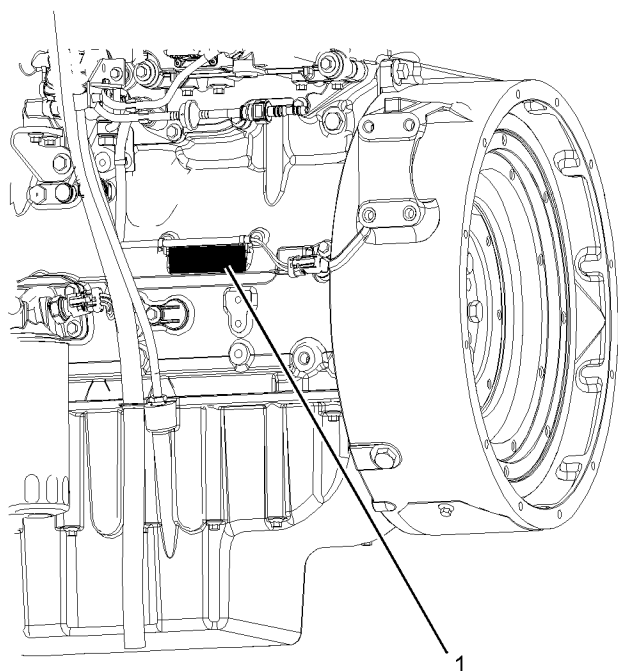

Illustration 21 g01248563

Location of the serial number plate

Perkins engines are identified by an engine serial number.

An example of an engine number is NH*****U000001J.

***** _____ The list number for the engine
 NH _____ Type of engine
 U _____ Built in the United Kingdom
 000001 _____ Engine Serial Number
 J _____ Year of Manufacture

Perkins dealers or Perkins distributors need all of these numbers in order to determine the components that were included with the engine. This permits accurate identification of replacement part numbers.

The numbers for fuel setting information for electronic engines are stored within the personality module. These numbers can be read by using the Electronic Service Tool.

Serial Number Plate (1)

The engine serial number plate is located on the left side of the cylinder block to the rear of the engine.



Illustration 22 g01094203

Serial number plate

i02164876

Reference Numbers

Information for the following items may be needed to order parts. Locate the information for your engine. Record the information in the appropriate space. Make a copy of this list for a record. Keep the information for future reference.

Record for Reference

- Engine Model _____
- Engine Serial number _____
- Engine Low Idle rpm _____
- Engine Full Load rpm _____
- Primary Fuel Filter _____
- Water Separator Element _____
- Secondary Fuel Filter Element _____
- Lubrication Oil Filter Element _____
- Auxiliary Oil Filter Element _____
- Total Lubrication System Capacity _____
- Total Cooling System Capacity _____
- Air Cleaner Element _____

Fan Drive Belt _____
Alternator Belt _____

i02861254

Emissions Certification Film

IMPORTANT ENGINE INFORMATION			Engine Type		
Engine Family: #####12#### #####: #####12#####		Displacement: ##4#	 120R-###6## eI1*97 68## #####16##### ##4#: #####15#####	Factory setting	Reset if Applicable
EPA Family Max Values	Advertised kw: ##5## Fuel Rate: ##4# mm3/stk Init. Timing: #####	MLIT ###7## ##4#/##4# ##4#/##4#		<input type="checkbox"/> ##4#/##4#	<input type="checkbox"/>
Settings are to be made with engine at normal operating temperature with transmission in neutral. This engine conforms to 2004 U.S. EPA non - road and California off - road Regulations for large C.I. engines and is certified to operate on commercially available diesel fuel.					
Emission Control System: #####16#####	Valve Lash Cold (inch): Exhaust ##5## Inlet ##5##	FEL (g/kWh) NOx+NMHC:## PM:##	Use Service Tool to verify current engine settings		
Hanger No. #3#	position ##4#	Label No. #####			

Operation Section

Lifting and Storage

i08066305

Engine Lifting

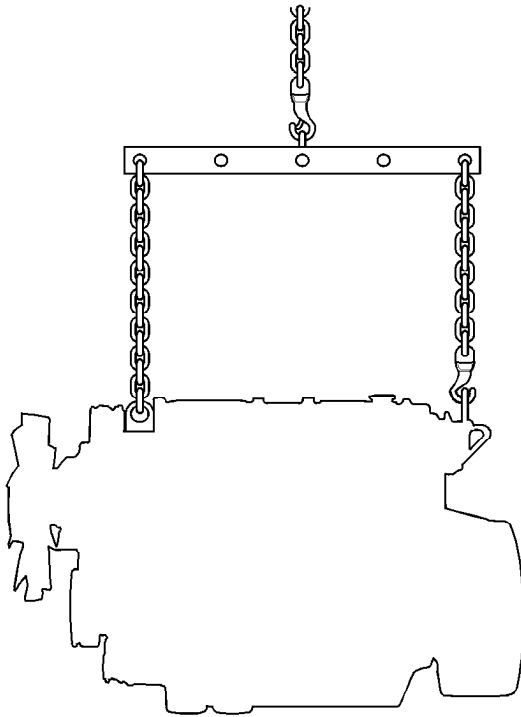

Illustration 24

g01097527

NOTICE

Never bend the eyebolts and the brackets. Only load the eyebolts and the brackets under tension. Remember that the capacity of an eyebolt is less as the angle between the supporting members and the object becomes less than 90 degrees.

When it is necessary to remove a component at an angle, only use a link bracket that is properly rated for the weight.

NOTICE

Always inspect lifting eyebolts and all other lifting equipment for damage before performing any lifting. Never bend the eyebolts and the brackets. Never perform product lifting if the components are damaged.

Use a hoist to remove heavy components. Use an adjustable lifting beam to lift the engine. All supporting members (chains and cables) should be parallel to each other. The chains and cables should be perpendicular to the top of the object that is being lifted.

Some removals require lifting the fixtures to obtain correct balance and safety.

To remove the engine ONLY, use the lifting eyes that are on the engine.

Lifting eyes are designed and installed for specific engine arrangements. Alterations to the lifting eyes and/or the engine make the lifting eyes and the lifting fixtures obsolete. If alterations are made, ensure that correct lifting devices are provided. Consult your Perkins dealer or your Perkins distributor for information regarding fixtures for correct engine lifting.

Engine Only

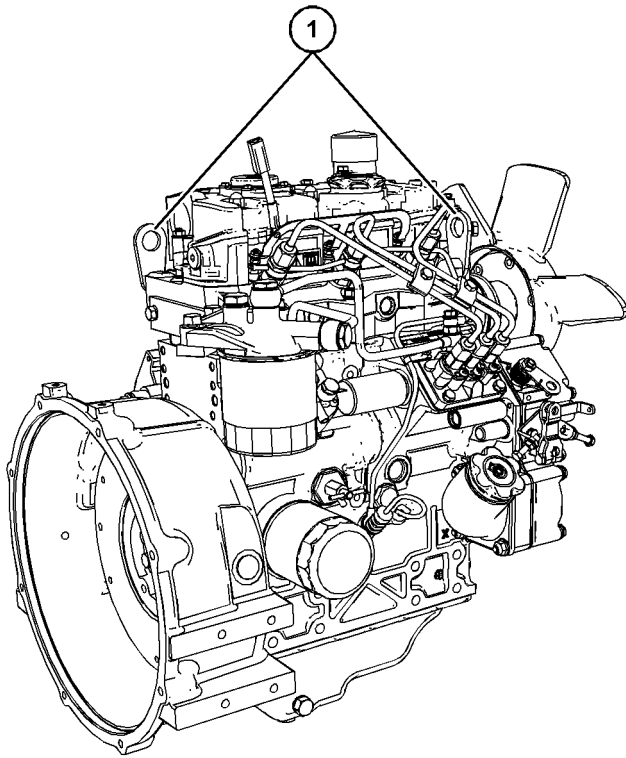

Illustration 25

g06531058

Typical example of Industrial Engine

(1) Front and rear lifting eyes

Engines with Factory Installed Radiators

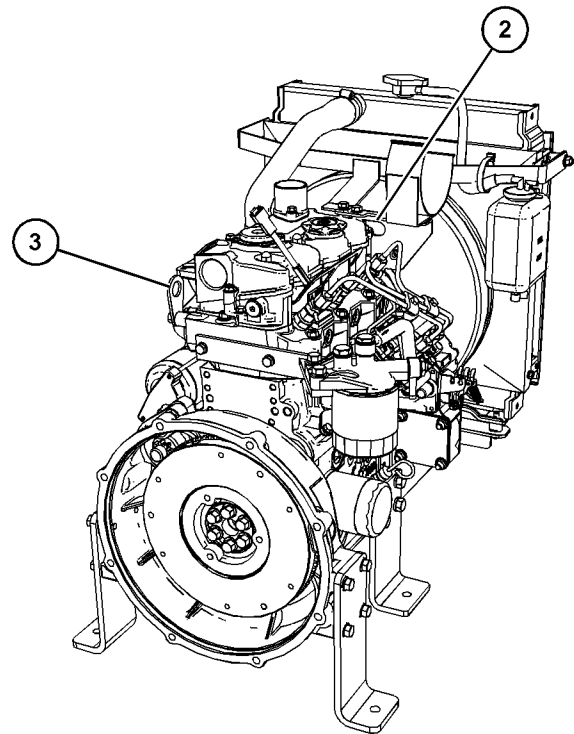

Illustration 26

g06531094

Typical example Industrial Open Power Unit (IOPU)

(2) Front lifting eye

(3) Rear lifting eye

i02308881

Engine Storage

If the engine is not started for a month or longer the lubricating oil will drain from the cylinder walls and from the piston rings. Rust can form on the cylinder walls. Rust on the cylinder walls will cause increased engine wear and a reduction in engine service life.

Perkins are not responsible for damage which may occur when an engine is in storage after a period in service.

Your Perkins dealer or your Perkins distributor can assist in preparing the engine for extended storage periods.

If an engine is out of operation and if use of the engine is not planned for more than one month, a complete protection procedure is recommended.

To help prevent excessive engine wear and corrosion to the engine, use the following guidelines:

1. Completely clean the outside of the engine.
2. Ensure that the vehicle is on level ground.
3. Drain the fuel system completely and refill the system with preservative fuel. 1772204 POWERPART Lay-Up 1 can be mixed with the normal fuel in order to change the fuel into preservative fuel.

If preservative fuel is not available, the fuel system can be filled with normal fuel. This fuel must be discarded at the end of the storage period together with the fuel filter elements.

WARNING

Personal injury can result from hot coolant. Any contact with hot coolant or with steam can cause severe burns. Allow cooling system components to cool before the cooling system is drained.

4. Drain and refill the cooling system. Refer to this Operation and Maintenance Manual, "Cooling System coolant (Commercial Heavy Duty - Change or Cooling System coolant (ELC) - Change" for information on draining, flushing and refilling the cooling system.

WARNING

Contact with high pressure fuel may cause fluid penetration and burn hazards. High pressure fuel spray may cause a fire hazard. Failure to follow these inspection, maintenance and service instructions may cause personal injury or death.

5. Operate the engine until the engine reaches normal operating temperature. Stop the engine. After the engine has stopped, you must wait for 60 seconds in order to allow the fuel pressure to be purged from the high pressure fuel lines before any service or repair is performed on the engine fuel lines. If necessary, perform minor adjustments. Repair any leaks from the low pressure fuel system and from the cooling, lubrication or air systems. Replace any high pressure fuel line that has leaked. Refer to Disassembly and assembly Manual, "Fuel Injection Lines - Install".
6. Drain the lubricating oil from the oil pan.
Renew the canister(s) of the lubricating oil filter.

Fill the oil pan to the Full Mark on the engine oil level gauge with new, clean lubricating oil. Add 1762811 POWERPART Lay-Up 2 to the oil in order to protect the engine against corrosion. If 1762811 POWERPART Lay-Up 2 is not available, use a preservative of the correct specification instead of the lubricating oil. If a preservative is used, this must be drained completely at the end of the storage period and the oil pan must be refilled to the correct level with normal lubricating oil.

7. Operate the engine in order to circulate engine oil.
8. Disconnect the battery. Ensure that the battery is in a fully charged condition. Protect the terminals against corrosion. 1734115 POWERPART Lay-Up 3 can be used on the terminals. Put the battery into safe storage.
9. If equipped, replace the crankcase breather element. Seal the end of the breather pipe.
10. Remove the valve mechanism cover. Spray 1762811 POWERPART Lay-Up 2 around the rocker shaft assembly.
11. Remove the glow plugs. Slowly rotate the crankshaft. By checking the valves, position the piston at BDC. Spray 1762811 POWERPART Lay-Up 2 for two seconds into the cylinder bore. This procedure must be carried out on each cylinder.
12. Install the glow plugs. Install the valve mechanism cover.
13. Remove the pipes that are installed between the air filter assembly and the turbocharger. Spray 1762811 POWERPART Lay-Up 2 into the turbocharger. The duration of the spray is printed on the container. Seal the turbocharger with waterproof tape.
14. Remove the exhaust pipe from the output side of the turbocharger. Spray 1762811 POWERPART Lay-Up 2 into the turbocharger. The duration of the spray is printed on the container. Seal the turbocharger with waterproof tape.
15. Seal the vent of the fuel tank or the fuel filler cap with waterproof tape.
16. Remove the alternator drive belt and put the drive belt into storage.
17. In order to prevent corrosion to the outside of the engine, spray the engine with 1734115 POWERPART Lay-Up 3. Do not spray the area inside the alternator.

Gauges and Indicators

i02861754

Gauges and Indicators

Your engine may not have the same gauges or all of the gauges that are described. For more information about the gauge package, see the OEM information.

Gauges provide indications of engine performance. Ensure that the gauges are in good working order. Determine the normal operating range by observing the gauges over a period of time.

Noticeable changes in gauge readings indicate potential gauge or engine problems. Problems may also be indicated by gauge readings that change even if the readings are within specifications. Determine and correct the cause of any significant change in the readings. Consult your Perkins dealer or your Perkins distributor for assistance.

Some engine applications are equipped with Indicator Lamps. Indicator lamps can be used as a diagnostic aid. There are two lamps. One lamp has an orange lens and the other lamp has a red lens.

These indicator lamps can be used in two ways:

- The indicator lamps can be used to identify the current operational status of the engine. The indicator lamps can also indicate that the engine has a fault. This system is automatically operated via the ignition switch.
- The indicator lamps can be used to identify active diagnostic codes. This system is activated by pressing the Flash Code button.

Refer to the Troubleshooting Guide, "Indicator Lamps" for further information.

NOTICE

If no oil pressure is indicated, STOP the engine. If maximum coolant temperature is exceeded, STOP the engine. Engine damage can result.



Engine Oil Pressure – The oil pressure should be greatest after a cold engine is started. The typical engine oil pressure with SAE10W40 is 350 to 450 kPa (50 to 65 psi) at rated rpm.

A lower oil pressure is normal at low idle. If the load is stable and the gauge reading changes, perform the following procedure:

1. Remove the load.
2. Stop the engine.

3. Check and maintain the oil level.



Jacket Water Coolant Temperature – Typical temperature range is 83° to 95°C (181.4° to 171°F). The maximum allowable temperature at sea level with the pressurized cooling system at 48 kPa (7 psi) is 103 °C (217.4 °F). Higher temperatures may occur under certain conditions. The water temperature reading may vary according to load. The temperature reading should never exceed 7 °C (44.6 °F) below the boiling point for the pressurized system that is being used.

A 100 kPa (14.5 psi) radiator cap may be installed on the cooling system. The temperature of this cooling system must not exceed 112 °C (233.6 °F).

If the engine is operating above the normal range and steam becomes apparent, perform the following procedure:

1. Reduce the load and the engine rpm.
2. Determine if the engine must be shut down immediately or if the engine can be cooled by reducing the load.
3. Inspect the cooling system for leaks.



Tachometer – This gauge indicates engine speed (rpm). When the throttle control lever is moved to the full throttle position without load, the engine is running at high idle. The engine is running at the full load rpm when the throttle control lever is at the full throttle position with maximum rated load.

NOTICE

To help prevent engine damage, never exceed the high idle rpm. Overspeeding can result in serious damage to the engine. Operation at speeds exceeding high idle rpm should be kept to a minimum.



Ammeter – This gauge indicates the amount of charge or discharge in the battery charging circuit. Operation of the indicator should be to the "+" side of "0" (zero).



Fuel Level – This gauge indicates the fuel level in the fuel tank. The fuel level gauge operates when the "START/STOP" switch is in the "on" position.



Service Hour Meter – The gauge indicates total operating hours of the engine.

Features and Controls

i02296746

Monitoring System

Table 2

Warning Lamp	Shutdown Lamp	Lamp Status	Description of lamp status	Engine Status
ON	ON	Lamp check	When the engine start switch is turned to the "ON" position both lamps will illuminate for 2 seconds only.	The engine has not been started.
OFF	OFF	No faults	There are no active diagnostic faults.	The engine is running normally.
ON	OFF	Active diagnostic fault	An active diagnostic fault has been detected.	The engine is running normally.
ON	FLASHING	Active diagnostic fault	A serious active diagnostic fault has been detected and an engine derate has been invoked.	The engine is running but the engine has been derated.
FLASHING	OFF	Warning	One or more of the engine protection values has been exceeded.	The engine is running normally.
FLASHING	FLASHING	Derate and warning	One or more of the engine protection values has been exceeded.	The engine is running but the engine has been derated.
ON	ON	Engine shutdown	One or more of the engine protection values has been exceeded or a serious active diagnostic fault has been detected.	The engine is shutdown or shutdown is imminent.

i02651062

Monitoring System

- Engine Oil pressure
- Pressure in the fuel rail
- Engine speed/timing

WARNING

If the Shutdown mode has been selected and the warning indicator activates, engine shutdown may take as little as 20 seconds from the time the warning indicator is activated. Depending on the application, special precautions should be taken to avoid personal injury. The engine can be re-started following shutdown for emergency maneuvers, if necessary.

NOTICE

The Engine Monitoring System is not a guarantee against catastrophic failures. Programmed delays and derate schedules are designed to minimize false alarms and provide time for the operator to stop the engine.

The following parameters are monitored:

- Coolant temperature
- Intake air temperature
- Engine intake manifold pressure

Programmable Options and Systems Operation

WARNING

If the Warning/Derate/Shutdown mode has been selected and the warning indicator activates, bring the engine to a stop whenever possible. Depending on the application, special precautions should be taken to avoid personal injury.

The engine can be programmed to the following modes:

"Warning"

The "Warning" lamp and the warning signal (orange lamp) turn "ON" and the warning signal is activated continuously in order to alert the operator that one or more of the engine parameters is not within normal operating range.

“Warning/Derate”

The “Diagnostic” lamp turns “ON” and the warning signal (red lamp) is activated. After the warning, the engine power will be derated. The warning lamp will begin to flash when the derating occurs.

The engine will be derated if the engine exceeds preset operational limits. The engine derate is achieved by restricting the amount of fuel that is available for each injection. The amount of this reduction of fuel is dependent on the severity of the fault that has caused the engine derate, typically up to a limit of 50%. This reduction in fuel results in a predetermined reduction in engine power.

“Warning/Derate/Shutdown”

The “Diagnostic” lamp turns “ON” and the warning signal (red lamp) is activated. After the warning, the engine power will be derated. The engine will continue at the rpm of the set derate until a shutdown of the engine occurs. The engine can be restarted after a shutdown for use in an emergency.

A shutdown of the engine may occur in as little as 20 seconds. The engine can be restarted after a shutdown for use in an emergency. However, the cause of the initial shutdown may still exist. The engine may shut down again in as little as 20 seconds.

If there is a signal for low oil pressure or for coolant temperature, there will be a two second delay in order to verify the condition.

For each of the programmed modes, refer to Troubleshooting , “Indicator Lamps” for more information on Indicator Lamps.

For more information or assistance for repairs, consult your Perkins dealer or your Perkins distributor.

i02861773

Sensors and Electrical Components

Sensor Locations

Illustration 27 shows the typical locations of the sensors and the ECM on the engine. Specific engines may appear different from the illustration due to differences in applications.

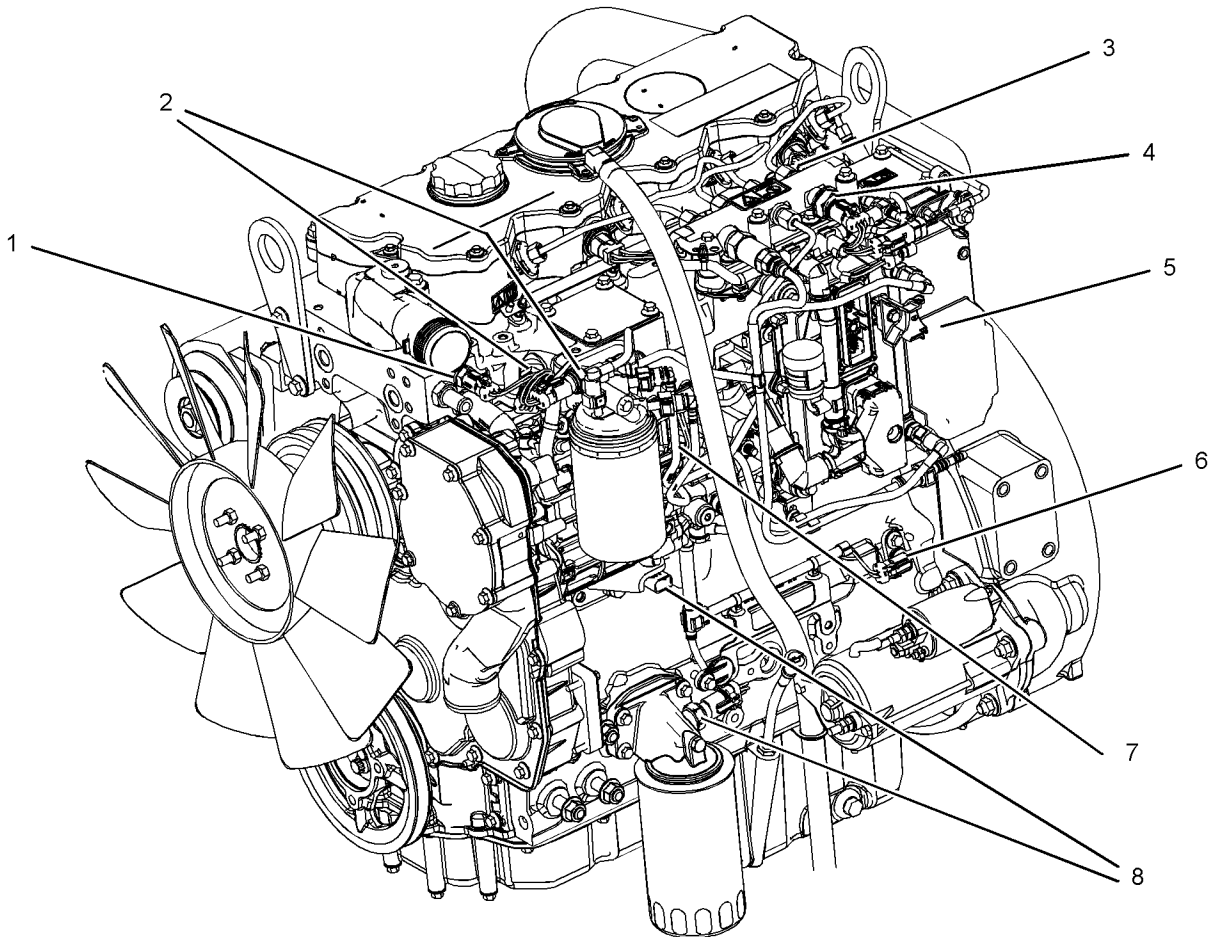

Illustration 27

g01425443

(1) Coolant temperature sensor
(2) Intake manifold pressure sensor
(3) Inlet air temperature sensor

(4) Fuel pressure sensor
(5) Electronic control module
(6) Primary position sensor

(7) Secondary position sensor
(8) Engine oil pressure sensor

Illustration 28 shows the sensors and the ECM in position on the engine.

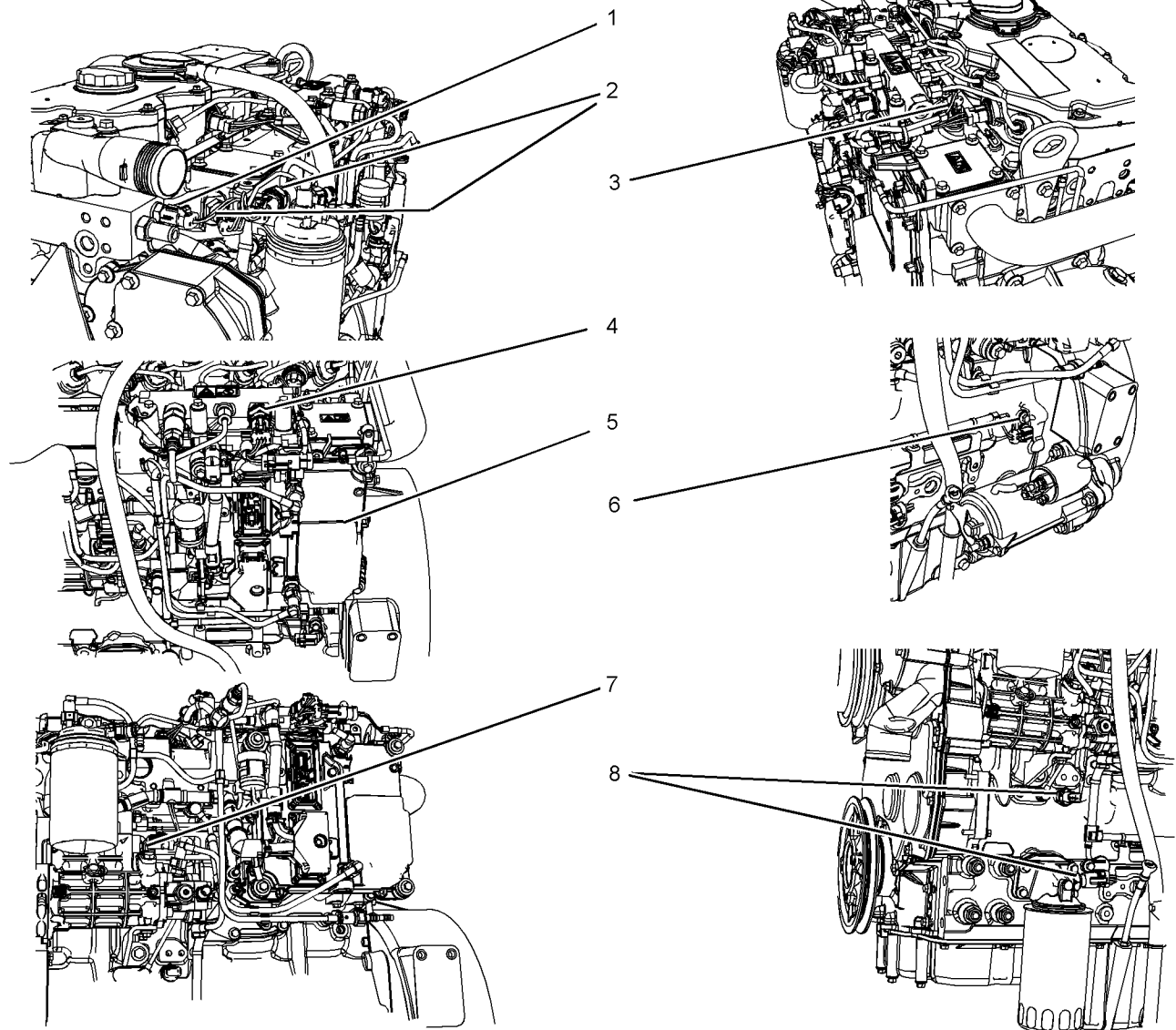

Illustration 28

g01425468

Failure of Sensors

All Sensors

A failure of any of the sensors may be caused by one of the following malfunctions:

- Sensor output is open.
- Sensor output is shorted to “- battery” or “+ battery” .

- Measured reading of the sensor is out of the specification.

Programmable Monitoring System (PMS)

The Programmable Monitoring System determines the level of action that is taken by the Electronic Control Module (ECM) in response to a condition that can damage the engine. These conditions are identified by the ECM from the signals that are produced from the following sensors.

- Coolant Temperature Sensor
- Intake manifold Air Temperature Sensor
- Intake manifold Pressure Sensor

- Fuel Pressure Sensor
- Engine Oil Pressure Sensor
- Primary Speed/Timing Sensor
- Secondary Speed/Timing Sensor

Coolant Temperature Sensor 1

The coolant temperature sensor monitors engine coolant temperature. The output of the ECM (5) can indicate a high coolant temperature through a relay or a lamp. The coolant temperature sensor is used by the ECM to determine initiation of the Cold Start Condition.

Failure of the Coolant Temperature Sensor

The ECM (5) will detect a failure of the coolant temperature sensor. The diagnostic lamp will warn the operator about the status of the coolant temperature sensor. A failure of the coolant temperature sensor will not cause a shutdown of the engine or any horsepower change. In order to check the correct operation of the sensor, refer to Troubleshooting, "Engine Temperature Sensor Circuit - Test".

Intake Manifold Air Temperature Sensor 2

Note: This sensor can have two different locations. The location will depend on the type of engine.

The intake manifold air temperature sensor measures the intake air temperature. A signal is sent to the ECM (5). The intake manifold air temperature sensor is also used by the ECM to determine initiation of the Cold Start Strategy.

In order to check the correct operation of the sensor, refer to Troubleshooting, "Engine Temperature Sensor Circuit - Test".

Intake Manifold Pressure Sensor 3

The intake manifold pressure sensor measures pressure in the manifold. A signal is sent to the ECM (5).

Fuel Pressure Sensor 4

The fuel pressure sensor measures the fuel pressure in the fuel manifold. A signal is sent to the ECM (5).

Electronic Control Module 5

The ECM is the control computer of the engine. The ECM provides power to the electronics. The ECM monitors data that is input from the sensors of the engine. The ECM acts as a governor in order to control the speed and the power of the engine.

The ECM adjusts injection timing and fuel pressure for the best engine performance, the best fuel economy and the best control of exhaust emissions.

Primary Speed/Timing Sensor 6

If the ECM (5) does not receive a signal from the primary speed/timing sensor, the "DIAGNOSTIC" lamp will indicate a diagnostic fault code which will be logged in the ECM memory.

If the ECM does not receive a signal from the primary speed/timing sensor (7), the ECM will read the signal from the secondary speed/timing sensor (8). The ECM continually checks in order to determine if there is a signal from both sensors.

Intermittent failure of the sensors will cause erratic engine control.

Failure of the Primary Speed/Timing Sensor

Correct operation of the primary speed/timing sensor is essential. Software in the ECM protects against reverse running of the engine. If the primary speed/timing sensor fails there is no automatic protection against reverse running. In some applications, it is possible for the transmission to run the engine in reverse. In this event, Stop the engine immediately. Turn the keyswitch to the "OFF" position.

In order to check the correct operation of the sensor, refer to Troubleshooting, "Engine speed/Timing sensor - Test".

Secondary Speed/Timing Sensor 7

The signal from the secondary speed/timing sensor is used by the ECM (5) on engine start-up in order to check the stroke of the pistons. The secondary speed/timing sensor may be used by the ECM in order to operate the engine if the primary speed/timing sensor is faulty.

In order to check the correct operation of the sensor, refer to Troubleshooting, "Engine speed/Timing sensor-Test".

Engine Oil Pressure Sensor 8

Note: This sensor can have two different locations. The location will depend on the type of engine.

The engine oil pressure sensor is an absolute pressure sensor that measures the engine oil pressure in the main oil gallery. The engine oil pressure sensor detects engine oil pressure for diagnostic purposes. The engine oil pressure sensor sends a signal to the ECM (5).

Low Oil Pressure Warning

The setpoint for the low pressure warning is dependent upon the engine speed. The fault will be active and logged only if the engine has been running for more than 8 seconds.

Very Low Oil Pressure Warning

The very low oil pressure setpoint is dependent upon the engine speed. If the DERATE mode of the engine monitoring system is selected, the ECM (5) will derate the engine power. The engine horsepower will be limited.

Failure of the Engine Oil Pressure Sensor

The ECM (5) will detect failure of the engine oil pressure sensor. The diagnostic lamp warns the user about the status of the engine oil pressure sensor. The engine oil pressure related strategies will be disabled in the event of a failure of the engine oil pressure sensor. A failure of the engine oil pressure sensor will not cause a shutdown of the engine or any horsepower change. In order to check the correct operation of the sensor, refer to Troubleshooting, "5 Volt Sensor Supply Circuit - Test".

i02858345

Engine Shutoffs and Engine Alarms

Shutoffs

The shutoffs are electrically operated or mechanically operated. The electrically operated shutoffs are controlled by the ECM.

Shutoffs are set at critical levels for the following items:

- Operating temperature
- Operating pressure
- Operating level
- Operating rpm

The particular shutoff may need to be reset before the engine will start.

NOTICE

Always determine the cause of the engine shutdown. Make necessary repairs before attempting to restart the engine.

Be familiar with the following items:

- Types and locations of shutoff
- Conditions which cause each shutoff to function
- The resetting procedure that is required to restart the engine

Alarms

The alarms are electrically operated. The operation of the alarms are controlled by the ECM.

The alarm is operated by a sensor or by a switch. When the sensor or the switch is activated a signal is sent to the ECM. An event code is created by the ECM. The ECM will send a signal in order to illuminate the lamp.

Your engine may be equipped with the following sensors or switches:

Coolant level – The low coolant level switch indicates when the coolant level is low.

Coolant temperature – The coolant temperature sensor indicates high jacket water coolant temperature.

Intake manifold air temperature – The intake manifold air temperature sensor indicates high intake air temperature.

Intake manifold pressure – The intake manifold pressure sensor checks the rated pressure in the engine manifold.

Fuel rail pressure – The fuel rail pressure sensor checks for high pressure or low pressure in the fuel rail.

Engine oil pressure – The engine oil pressure sensor indicates when oil pressure drops below rated system pressure, at a set engine speed.

Engine overspeed – The primary speed/timing sensor checks the engine speed. The alarm is activated at 3000 RPM.

Air filter restriction – The switch checks the air filter when the engine is operating.

User defined switch – This switch can shut down the engine remotely.

Water in fuel switch – This switch checks for water in the primary fuel filter when the engine is operating.

Note: The sensing element of the coolant temperature switch must be submerged in coolant in order to operate.

Engines may be equipped with alarms in order to alert the operator when undesirable operating conditions occur.

If corrective measures are not taken within a reasonable time, engine damage could result. The alarm will continue until the condition is corrected. The alarm may need to be reset.

Testing

Turning the keyswitch to the ON position will check the indicator lights on the control panel. All the indicator lights will be illuminated for two seconds after the keyswitch is operated. Replace suspect bulbs immediately.

Refer to Troubleshooting for more information.

i02237393

Overspeed

An overspeed condition is detected by the Electronic Control Module (ECM). The event code will be logged if the engine speed exceeds 3000 rpm. The "DIAGNOSTIC" lamp will indicate a diagnostic active code. The diagnostic active code will remain active until the engine speed drops to 2800 rpm.

NOTICE

When an alarm is activated, corrective measures must be taken before the situation becomes an emergency in order to avoid possible engine damage.

Engine Diagnostics

i02855276

i02651093

Self-Diagnostics

Perkins electronic engines have the capability to perform a self-diagnostics test. When the system detects an active problem, a diagnostic lamp is activated. Diagnostic codes will be stored in permanent memory in the Electronic Control Module (ECM). The diagnostic codes can be retrieved by using the electronic service tool. Refer to Troubleshooting , “Electronic Service Tools” for further information.

Some installations have electronic displays that provide direct readouts of the engine diagnostic codes. Refer to the manual that is provided by the OEM for more information on retrieving engine diagnostic codes. Alternatively refer to Troubleshooting , “Indicator Lamps” for further information.

Active codes represent problems that currently exist. These problems should be investigated first.

Logged codes represent the following items:

- Intermittent problems
- Recorded events
- Performance history

The problems may have been repaired since the logging of the code. These codes do not indicate that a repair is needed. The codes are guides or signals when a situation exists. Codes may be helpful to troubleshoot problems.

When the problems have been corrected, the corresponding logged fault codes should be cleared.

i02651107

Diagnostic Lamp

A diagnostic lamp is used to indicate the existence of an active fault. Refer to Troubleshooting , “Indicator Lamps” for more information. A fault diagnostic code will remain active until the problem is repaired. The diagnostic code may be retrieved by using the electronic service tool. Refer to Troubleshooting , “Electronic Service Tools” for more information.

Diagnostic Flash Code Retrieval

“Diagnostic” Lamp

Use the “DIAGNOSTIC” Lamp or an electronic service tool to determine the diagnostic flash code.

Use the following procedure to retrieve the flash codes if the engine is equipped with a “DIAGNOSTIC” lamp:

1. Turn the keyswitch “ON/OFF” two times within 3 seconds.

A flashing “YELLOW” lamp indicates a 3 digit code for the engine. The sequence of flashes represents the system diagnostic message. Count the first sequence of flashes in order to determine the first digit of the flash code. After a two second pause, the second sequence of flashes will identify the second digit of the flash code. After the second pause, the third sequence of flashes will identify the flash code.

Any additional flash codes will follow after a pause. These codes will be displayed in the same manner. Flash Code 551 indicates that No Detected Faults have occurred since the ignition keyswitch has been turned to the ON position.

For further information, assistance for repairs, or troubleshooting, refer to the Service Manual or consult an authorized Perkins dealer.

Table 3 lists the flash codes and the table also gives a brief description of the flash codes.

Note: Table 3 indicates the potential effect on engine performance with “ACTIVE” flash codes.

Some codes record events. Also, some codes may also indicate that a mechanical system needs attention. Troubleshooting is not required for code “551” . Code 001 will not display a flash code. Some codes will limit the operation or the performance of the engine.

Table 3 indicates the potential effect on the engine performance with active flash codes. Table 3 also forms a list of Electronic diagnostic codes and descriptions.

Table 3

Flash Codes for the Industrial Engine								
Diagnostic Flash Code		Effect On Engine Performance ⁽¹⁾				Suggested Operator Action		
		Engine Misfire	Low Power	Reduced Engine Speed	Engine Shutdown	Shut Down the Engine ⁽²⁾	Service ⁽³⁾	Schedule a Service. ⁽⁴⁾
111	Cylinder 1 Fault	X	X				X	
112	Cylinder 2 Fault	X	X				X	
113	Cylinder 3 Fault	X	X				X	
114	Cylinder 4 Fault	X	X				X	
133	Intake Manifold Temperature sensor fault ⁽⁵⁾	X					X	
141	Primary Speed/Timing Sensor Fault			X			X	
142	Secondary Speed/Timing Sensor Fault						X	
143	Timing Calibration Fault	X						X
144	Engine Operation Mode Selector Switch Fault		X				X	
151	High Air Filter Restriction		X				X	
154	Throttle Position sensor Fault			X			X	
155	Secondary Throttle Position sensor Fault			X			X	
157	Oil Pressure Sensor Fault ⁽⁵⁾		X	X	X	X	X	
159	Fuel Rail Pressure Sensor Fault		X				X	
162	High Pressure Fuel Pump Fault		X	X			X	
168	Coolant Temperature Sensor Fault			X	X		X	
169	Low Engine Coolant				X			X
177	Wastegate Solenoid Fault			X				
185	High Exhaust Temperature		X				X	
197	Intake Manifold Pressure Sensor Fault		X				X	
199	Glow Plug Start Relay Fault						X	
415	Incorrect Engine Software			X	X		X	
426	Machine Security System Module Fault ⁽⁶⁾						X	

(continued)

(Table 3, contd)

Flash Codes for the Industrial Engine								
Diagnostic Flash Code		Effect On Engine Performance ⁽¹⁾				Suggested Operator Action		
		Engine Misfire	Low Power	Reduced Engine Speed	Engine Shutdown	Shut Down the Engine ⁽²⁾	Service ⁽³⁾	Schedule a Service. ⁽⁴⁾
429	Keyswitch Fault							X
511	Intermittent Battery Power to ECM	X	X		X		X	
514	SAE J1939 Data Link Fault			X			X	
516	5 Volt Sensor DC Power Supply Fault ⁽⁵⁾		X					X
517	8 Volt Sensor DC Power Supply Fault		X					X
527	Check Customer Parameters or System Parameters ⁽⁵⁾		X	X				X

(1) An "X" indicates that the effect on engine performance may occur if the code is active.

(2) Shut Down the Engine: Operate the engine cautiously. Get immediate service. Severe engine damage may result.

(3) The operator should go to the nearest location that has a qualified service program.

(4) Schedule Service: The problem should be investigated when the operator has access to a qualified service program.

(5) These Flash Codes may affect the system under specific environmental conditions such as engine start-up at cold temperature and cold weather operation at high altitudes.

(6) The engine will not start.

i01902949

Fault Logging

The system provides the capability of Fault Logging. When the Electronic Control Module (ECM) generates an active diagnostic code, the code will be logged in the memory of the ECM. The codes that have been logged by the ECM can be identified by the electronic service tool. The active codes that have been logged will be cleared when the fault has been rectified or the fault is no longer active. The following logged faults can not be cleared from the memory of the ECM without using a factory password: Overspeed, low engine oil pressure and high engine coolant temperature.

i02651197

Engine Operation with Active Diagnostic Codes

If a diagnostic lamp illuminates during normal engine operation, the system has identified a situation that is not within the specification. Use the electronic service tool to check the active diagnostic codes.

The active diagnostic code should be investigated. The cause of the problem should be corrected as soon as possible. If the cause of the active diagnostic code is repaired and there is only one active diagnostic code, the diagnostic lamp will turn off.

Operation of the engine and performance of the engine can be limited as a result of the active diagnostic code that is generated. Acceleration rates may be significantly slower and power outputs may be automatically reduced. Refer to Troubleshooting , "Troubleshooting with a Diagnostic Code" for more information on the relationship between each active diagnostic code and the possible effect on engine performance.

i01902995

Engine Operation with Intermittent Diagnostic Codes

If a diagnostic lamp illuminates during normal engine operation and the diagnostic lamp shuts off, an intermittent fault may have occurred. If a fault has occurred, the fault will be logged into the memory of the Electronic Control Module (ECM).

In most cases, it is not necessary to stop the engine because of an intermittent code. However, the operator should retrieve the logged fault codes and the operator should reference the appropriate information in order to identify the nature of the event. The operator should log any observation that could have caused the lamp to light.

- Low power
- Limits of the engine speed
- Excessive smoke, etc

This information can be useful to help troubleshoot the situation. The information can also be used for future reference. For more information on diagnostic codes, refer to the Troubleshooting Guide for this engine.

Engine Starting

i02322201

Before Starting Engine

Before the engine is started, perform the required daily maintenance and any other periodic maintenance that is due. Refer to the Operation and Maintenance Manual, "Maintenance Interval Schedule" for more information.

- Open the fuel supply valve (if equipped).

NOTICE

All valves in the fuel return line must be open before and during engine operation to help prevent high fuel pressure. High fuel pressure may cause filter housing failure or other damage.

If the engine has not been started for several weeks, fuel may have drained from the fuel system. Air may have entered the filter housing. Also, when fuel filters have been changed, some air pockets will be trapped in the engine. In these instances, prime the fuel system. Refer to the Operation and Maintenance Manual, "Fuel System - Prime" for more information on priming the fuel system.

WARNING

Engine exhaust contains products of combustion which may be harmful to your health. Always start and operate the engine in a well ventilated area and, if in an enclosed area, vent the exhaust to the outside.

- Do not start the engine or move any of the controls if there is a "DO NOT OPERATE" warning tag or similar warning tag attached to the start switch or to the controls.
- Reset all of the shutoffs or alarm components (if equipped).
- Ensure that any equipment that is driven by the engine has been disengaged from the engine. Minimize electrical loads or remove any electrical loads.

i02322203

Starting the Engine

Note: Do not adjust the engine speed control during start-up. The electronic control module (ECM) will control the engine speed during start-up.

Starting the Engine

1. Disengage any equipment that is driven by the engine.
2. Turn the keyswitch to the RUN position. Leave the keyswitch in the RUN position until the warning light for the glow plugs is extinguished.
3. When the warning light for the glow plugs is extinguished turn the keyswitch to the START position in order to engage the electric starting motor and crank the engine.

Note: The operating period of the warning light for the glow plugs will change due to the temperature of the engine.

NOTICE

Do not engage the starting motor when flywheel is turning. Do not start the engine under load.

If the engine fails to start within 30 seconds, release the starter switch or button and wait two minutes to allow the starting motor to cool before attempting to start the engine again.

4. Allow the keyswitch to return to the RUN position after the engine starts.
5. Repeat step 2 through step 4 if the engine fails to start.

i02322204

Starting with Jump Start Cables

WARNING

Improper jump start cable connections can cause an explosion resulting in personal injury.

Prevent sparks near the batteries. Sparks could cause vapors to explode. Do not allow jump start cable ends to contact each other or the engine.

Note: If it is possible, first diagnose the reason for the starting failure. Refer to Troubleshooting, "Engine Will Not Crank and Engine Cranks But Will Not Start" for further information. Make any necessary repairs. If the engine will not start only due to the condition of the battery, either charge the battery, or start the engine by using another battery with jump start cables. The condition of the battery can be rechecked after the engine has been switched OFF.

NOTICE

Using a battery source with the same voltage as the electric starting motor. Use **ONLY** equal voltage for jump starting. The use of higher voltage will damage the electrical system.

Do not reverse the battery cables. The alternator can be damaged. Attach ground cable last and remove first.

Turn all electrical accessories OFF before attaching the jump start cables.

Ensure that the main power switch is in the OFF position before attaching the jump start cables to the engine being started.

1. Turn the start switch on the stalled engine to the OFF position. Turn off all the engine's accessories.
2. Connect one positive end of the jump start cable to the positive cable terminal of the discharged battery. Connect the other positive end of the jump start cable to the positive cable terminal of the electrical source.
3. Connect one negative end of the jump start cable to the negative cable terminal of the electrical source. Connect the other negative end of the jump start cable to the engine block or to the chassis ground. This procedure helps to prevent potential sparks from igniting the combustible gases that are produced by some batteries.
4. Start the engine.
5. Immediately after the engine is started, disconnect the jump start cables in reverse order.

After jump starting, the alternator may not be able to fully recharge batteries that are severely discharged. The batteries must be replaced or charged to the proper voltage with a battery charger after the engine is stopped. Many batteries which are considered unusable are still rechargeable. Refer to Operation and Maintenance Manual, "Battery - Replace" and Testing and Adjusting Manual, "Battery - Test".

i02330138

After Starting Engine

Note: In ambient temperatures from 0 to 60°C (32 to 140°F), the warm-up time is approximately three minutes. In temperatures below 0°C (32°F), additional warm-up time may be required.

When the engine idles during warm-up, observe the following conditions:

Do not check the high pressure fuel lines with the engine or the starting motor in operation. If you inspect the engine in operation, always use the proper inspection procedure in order to avoid a fluid penetration hazard. Refer to Operation and Maintenance Manual, "General hazard Information".

- Check for any fluid or for any air leaks at idle rpm and at one-half full rpm (no load on the engine) before operating the engine under load. This is not possible in some applications.
- Allow the engine to idle for three to five minutes, or allow the engine to idle until the water temperature indicator begins to rise. Check all gauges during the warm-up period.

Note: Gauge readings should be observed and the data should be recorded frequently while the engine is operating. Comparing the data over time will help to determine normal readings for each gauge. Comparing data over time will also help detect abnormal operating developments. Significant changes in the readings should be investigated.

Engine Operation

i02330143

Engine Operation

Correct operation and maintenance are key factors in obtaining the maximum life and economy of the engine. If the directions in the Operation and Maintenance Manual are followed, costs can be minimized and engine service life can be maximized.

The engine can be operated at the rated rpm after the engine reaches operating temperature. The engine will reach normal operating temperature if the engine is operated at low idle speed and operated with a light load. This procedure is more effective than idling the engine at no load. The engine should reach operating temperature in a few minutes.

Gauge readings should be observed and the data should be recorded frequently while the engine is operating. Comparing the data over time will help to determine normal readings for each gauge. Comparing data over time will also help detect abnormal operating developments. Significant changes in the readings should be investigated.

i02330149

Fuel Conservation Practices

The efficiency of the engine can affect the fuel economy. Perkins design and technology in manufacturing provides maximum fuel efficiency in all applications. Follow the recommended procedures in order to attain optimum performance for the life of the engine.

- Avoid spilling fuel.

Fuel expands when the fuel is warmed up. The fuel may overflow from the fuel tank. Inspect fuel lines for leaks. Repair the fuel lines, as needed.

- Be aware of the properties of the different fuels. Use only the recommended fuels.
- Avoid unnecessary idling.

Shut off the engine rather than idle for long periods of time.

- Observe the air cleaner service indicator frequently. Keep the air cleaner elements clean.
- Maintain the electrical systems.

One damaged battery cell will overwork the alternator. This will consume excess power and excess fuel.

- Ensure that the drive belts are correctly adjusted. The drive belts should be in good condition.
- Ensure that all of the connections of the hoses are tight. The connections should not leak.
- Ensure that the driven equipment is in good working order.
- Cold engines consume excess fuel. Utilize heat from the jacket water system and the exhaust system, when possible. Keep cooling system components clean and keep cooling system components in good repair. Never operate the engine without water temperature regulators. All of these items will help maintain operating temperatures.

Engine Stopping

i02330274

Stopping the Engine

i06832774

NOTICE

Stopping the engine immediately after it has been working under load, can result in overheating and accelerated wear of the engine components.

Avoid accelerating the engine prior to shutting it down.

Avoiding hot engine shutdowns will maximize turbo-charger shaft and bearing life.

Note: Individual applications will have different control systems. Ensure that the shutoff procedures are understood. Use the following general guidelines to stop the engine.

1. Remove the load from the engine. Reduce the engine speed (rpm) to low idle. Allow the engine to idle for 5 minutes to cool the engine.
2. Stop the engine after the cool down period according to the shutoff system on the engine. Turn the ignition key switch to the OFF position. If necessary, refer to the instructions that are provided by the OEM.

NOTICE

Before any service or repairs are performed, ensure that the power supply to the engine is disconnected.

i07764840

Emergency Stopping

NOTICE

Emergency shutoff controls are for EMERGENCY use ONLY. DO NOT use emergency shutoff devices or controls for normal stopping procedure.

The Original Equipment Manufacturer (OEM) may have equipped the application with an emergency stop button. For more information about the emergency stop button, refer to the OEM information.

Ensure that any components for the external system that support the engine operation are secured after the engine is stopped.

After Stopping Engine

Note: Before you check the engine oil, do not operate the engine for at least 10 minutes in order to allow the engine oil to return to the oil pan.

WARNING

Contact with high pressure fuel may cause fluid penetration and burn hazards. High pressure fuel spray may cause a fire hazard. Failure to follow these inspection, maintenance and service instructions may cause personal injury or death.

- After the engine has stopped, you must wait for 60 seconds in order to allow the fuel pressure to be purged from the high pressure fuel lines before any service or repair is performed on the engine fuel lines. If necessary, perform minor adjustments. Repair any leaks from the low pressure fuel system and from the cooling, lubrication or air systems. Replace any high pressure fuel line that has leaked. Refer to Disassembly and assembly Manual, "Fuel Injection Lines - Install".
- Check the crankcase oil level. Maintain the oil level between the "MIN" mark and the "MAX" mark on the engine oil level gauge.
- If the engine is equipped with a service hour meter, note the reading. Perform the maintenance that is in the Operation and Maintenance Manual, "Maintenance Interval Schedule".
- Fill the fuel tank in order to help prevent accumulation of moisture in the fuel. Do not overfill the fuel tank.

NOTICE

Only use antifreeze/coolant mixtures recommended in the Coolant Specifications that are in the Operation and Maintenance Manual. Failure to do so can cause engine damage.

WARNING

Pressurized System: Hot coolant can cause serious burns. To open the cooling system filler cap, stop the engine and wait until the cooling system components are cool. Loosen the cooling system pressure cap slowly in order to relieve the pressure.

- Allow the engine to cool. Check the coolant level.

Operation Section
After Stopping Engine

- Check the coolant for correct antifreeze protection and the correct corrosion protection. Add the correct coolant/water mixture, if necessary.
- Perform all required periodic maintenance on all driven equipment. This maintenance is outlined in the instructions from the OEM.

Cold Weather Operation

i05927231

Cold Weather Operation

Perkins Diesel Engines can operate effectively in cold weather. During cold weather, the starting and the operation of the diesel engine is dependent on the following items:

- The type of fuel that is used
- The viscosity of the engine oil
- The operation of the glow plugs
- Optional Cold starting aid
- Battery condition
- Ambient air temperature and altitude
- Parasitic load of the application
- Application hydraulic and transmission oil viscosities

This section will cover the following information:

- Potential problems that are caused by cold-weather operation
- Suggest steps which can be taken in order to minimize starting problems and operating problems when the ambient air temperature is between 0° to -40 °C (32° to 40 °F).

The operation and maintenance of an engine in freezing temperatures is complex . This complexity is because of the following conditions:

- Weather conditions
- Engine applications

Recommendations from your Perkins dealer or your Perkins distributor are based on past proven practices. The information that is contained in this section provides guidelines for cold-weather operation.

Hints for Cold Weather Operation

- If the engine will start, operate the engine until a minimum operating temperature of 81 °C (177.8 °F) is achieved. Achieving operating temperature will help prevent the intake valves and exhaust valves from sticking.

- The cooling system and the lubrication system for the engine do not lose heat immediately upon shutdown. This means that an engine can be shut down for a period of time, and the engine can still be able to start readily.
- Install the correct specification of engine lubricant before the beginning of cold weather.
- Check all rubber parts (hoses, fan drive belts.) weekly.
- Check all electrical wiring and connections for any fraying or damaged insulation.
- Keep all batteries fully charged and warm.
- Fill the fuel tank at the end of each shift.
- Check the air cleaners and the air intake daily. Check the air intake more often when you operate in snow.
- Ensure that the glow plugs are in working order. Refer to Testing and Adjusting Manual, "Glow Plug - Test".

WARNING

Personal injury or property damage can result from alcohol or starting fluids.

Alcohol or starting fluids are highly flammable and toxic and if improperly stored could result in injury or property damage.

WARNING

Do not use aerosol types of starting aids such as ether. Such use could result in an explosion and personal injury.

- For jump starting with cables in cold weather, refer to the Operation and Maintenance Manual, "Starting with Jump Start Cables." for instructions.

Viscosity of the Engine Lubrication Oil

Correct engine oil viscosity is essential. Oil viscosity affects the amount of torque that is needed to crank the engine. Refer to this Operation and Maintenance Manual, "Fluid Recommendations" for the recommended viscosity of oil.

Recommendations for the Coolant

Provide cooling system protection for the lowest expected outside temperature. Refer to this Operation and Maintenance Manual, "Fluid Recommendations" for the recommended coolant mixture.

In cold weather, check the coolant often for the correct glycol concentration in order to ensure adequate freeze protection.

Engine Block Heaters

Engine block heaters (if equipped) heat the engine jacket water that surrounds the combustion chambers. This heat provides the following functions:

- Startability is improved.
- Warm up time is reduced.

An electric block heater can be activated once the engine is stopped. An effective block heater is typically a 1250/1500 W unit. Consult your Perkins dealer or your Perkins distributor for more information.

Idling the Engine

When idling after the engine is started in cold weather, increase the engine rpm from 1000 to 1200 rpm. This increase in RPM will warm up the engine more quickly. Maintaining an elevated low idle speed for extended periods will be easier with the installation of a hand throttle. The engine should not be "raced" in order to speed up the warm-up process.

While the engine is idling, the application of a light load (parasitic load) will assist in achieving the minimum operating temperature. The minimum operating temperature is 82 °C (179.6 °F).

Recommendations for Coolant Warm Up

Warm up an engine that has cooled below normal operating temperatures due to inactivity. The warm-up should be performed before the engine is returned to full operation. During operation in very cold temperature conditions, damage to engine valve mechanisms can result from engine operation for short intervals. This action can happen if the engine is started and the engine is stopped many times without being operated in order to warm up completely.

When the engine is operated below normal operating temperatures, fuel and oil are not completely burned in the combustion chamber. This fuel and oil causes soft carbon deposits to form on the valve stems. Generally, the deposits do not cause problems and the deposits are burned off during operation at normal engine operating temperatures.

When the engine is started and the engine is stopped many times without being operated in order to warm up completely, the carbon deposits become thicker. This action can cause the following problems:

- Free operation of the valves is prevented.
- Valves become stuck.
- Pushrods may become bent.
- Other damage to valve train components can result.

For this reason, when the engine is started, the engine must be operated until the coolant temperature is 71 °C (160 °F) minimum. Carbon deposits on the valve stems will be kept at a minimum. The free operation of the valves and the valve components will be maintained.

In addition, the engine must be thoroughly warmed in order to keep other engine parts in better condition and the service life of the engine will be generally extended. Lubrication will be improved. There will be less acid and less sludge in the oil. This lubrication will provide longer service life for the engine bearings, the piston rings, and other parts. However, limit unnecessary idle time to 10 minutes in order to reduce wear and unnecessary fuel consumption.

The Water Temperature Regulator and Insulated Heater Lines

The engine is equipped with a water temperature regulator. When the engine coolant is below the correct operating temperature, jacket water circulates through the engine cylinder block and into the engine cylinder head. The coolant then returns to the cylinder block via an internal passage that bypasses the valve of the coolant temperature regulator. This system ensures that coolant flows around the engine under cold operating conditions. The water temperature regulator begins to open when the engine jacket water has reached the correct minimum operating temperature. As the jacket water coolant temperature rises above the minimum operating temperature the water temperature regulator opens further allowing more coolant through the radiator to dissipate excess heat.

The progressive opening of the water temperature regulator operates the progressive closing of the bypass passage between the cylinder block and head. This system ensures maximum coolant flow to the radiator in order to achieve maximum heat dissipation.

Note: Perkins discourages the use of all air flow restriction devices such as radiator shutters. Restriction of the air flow can result in the following: high exhaust temperatures, power loss, excessive fan usage and reduction in fuel economy.

A cab heater is beneficial in very cold weather. The feed from the engine and the return lines from the cab should be insulated in order to reduce heat loss to the outside air.

Insulating the Air Inlet and Engine Compartment

When temperatures below -18°C (-0°F) will be frequently encountered, an air cleaner inlet that is located in the engine compartment may be specified. An air cleaner that is located in the engine compartment may also minimize the entry of snow into the air cleaner. Also, heat that is rejected by the engine helps to warm the intake air.

Additional heat can be retained around the engine by insulating the engine compartment.

i07818744

Fuel and the Effect from Cold Weather

Note: Only use grades of fuel that are recommended by Perkins. Refer to this Operation and Maintenance Manual, "Fluid Recommendations".

Properties of the diesel fuel can have a significant effect on the engine cold start capability. It is critical that the low temperature properties of diesel fuel are acceptable for the minimum ambient temperature the engine is expected to see in operation.

Following properties are used to define fuels low temperature capability:

- Cloud point
- Pour point
- Cold Filter Plugging Point (CFPP)

The cloud point of the fuel is the temperature at which waxes naturally found in the diesel fuel begin to form crystals. The cloud point of the fuel must be below lowest ambient temperature to prevent filters from plugging.

Pour point is the last temperature before the fuel flow stops and waxing of the fuel will start.

Cold Filter Plugging Point (CFPP) is a temperature at which a particular fuel will pass through a standardized filtration device. This CFPP gives an estimate of the lower operability temperature of fuel

Be aware of these properties when diesel fuel is purchased. Consider the average ambient air temperature for the engines application. Engines that are fueled in one climate may not operate well if the engines are shipped to colder climate. Problems can result due to changes in temperature.

Before troubleshooting for low power or for poor performance in the winter, check the fuel for waxing

The following components can provide a means of minimizing fuel waxing problems in cold weather:

- Fuel heaters, which may be an OEM option
- Fuel line insulation, which may be an OEM option

Winter and arctic grades of diesel fuel are available in the countries and territories with severe winters. For more information refer to the Operation and Maintenance Manual, "Fuel For Cold-Weather Operation"

Another important fuel property which can affect cold start and operation of diesel engine is Cetane number. Detail and requirements of this property are given in this Operation and Maintenance Manual, "Fluid Recommendations".

i02323237

Fuel Related Components in Cold Weather

Fuel Tanks

Condensation can form in partially filled fuel tanks. Top off the fuel tanks after you operate the engine.

Fuel tanks should contain some provision for draining water and sediment from the bottom of the tanks.

Some fuel tanks use supply pipes that allow water and sediment to settle below the end of the fuel supply pipe.

Some fuel tanks use supply lines that take fuel directly from the bottom of the tank. If the engine is equipped with this system, regular maintenance of the fuel system filter is important.

Drain the water and sediment from any fuel storage tank at the following intervals: weekly, service intervals and refueling of the fuel tank. This will help prevent water and/or sediment from being pumped from the fuel storage tank and into the engine fuel tank.

Fuel Filters

A primary fuel filter is installed between the fuel tank and the engine fuel inlet. After you change the fuel filter, always prime the fuel system in order to remove air bubbles from the fuel system. Refer to the Operation and Maintenance Manual in the Maintenance Section for more information on priming the fuel system.

The location of a primary fuel filter is important in cold weather operation. The primary fuel filter and the fuel supply line are the most common components that are affected by cold fuel.

Fuel Heaters

Note: The OEM may equip the application with fuel heaters. If this is the case, the temperature of the fuel must not exceed 73 °C (163 °F) at the fuel transfer pump.

For more information about fuel heaters (if equipped), refer to the OEM information.

Maintenance Section

Refill Capacities

i04262329

Refill Capacities

Lubrication System

The refill capacities for the engine crankcase reflect the approximate capacity of the crankcase or sump plus standard oil filters. Auxiliary oil filter systems will require additional oil. Refer to the OEM specifications for the capacity of the auxiliary oil filter. Refer to the Operation and Maintenance Manual, "Maintenance Section" for more information on Lubricant Specifications.

Table 4

Engine Refill Capacities		
Compartment or System	Minimum ⁽¹⁾	Maximum ⁽²⁾
Crankcase Oil Sump	6 L (1.32 Imp gal)	14 L (3.1 Imp gal)

- (1) The minimum value is the approximate capacity for the crankcase oil sump (aluminum) which includes the standard factory installed oil filters. Engines with auxiliary oil filters will require additional oil. Refer to the OEM specifications for the capacity of the auxiliary oil filter. The design of the oil pan can change the oil capacity of the oil pan.
- (2) Approximate capacity of the largest crankcase oil sump. Refer to OEM for more information.

Cooling System

Refer to the OEM specifications for the External System capacity. This capacity information will be needed in order to determine the amount of coolant/antifreeze that is required for the Total Cooling System.

Table 5

Engine Refill Capacities		
Compartment or System	Liters	
	Engine	Engine
Engine Only	TA ⁽¹⁾	TTA ⁽²⁾
	9 L (1.97 Imp gal)	9.4 L (2.07 Imp gal)
External System Per OEM ⁽³⁾		

(1) Single Turbocharger

(2) Series Turbochargers

(3) The External System includes a radiator or an expansion tank with the following components: heat exchanger and piping. Refer to the OEM specifications. Enter the value for the capacity of the External System in this row.

i02788820

Fluid Recommendations (Fuel Specification)

- **Glossary**
- ISO International Standards Organization
- ASTM American Society for Testing and Materials
- HFRR High Frequency Reciprocating Rig for Lubricity testing of diesel fuels
- FAME Fatty Acid Methyl Esters
- CFR Co-ordinating Fuel Research
- LSD Low Sulfur Diesel
- ULSD Ultra Low Sulfur Diesel
- RME Rape Methyl Ester
- SME Soy Methyl Ester
- EPA Environmental Protection Agency of the United States

General Information

NOTICE

Every attempt is made to provide accurate, up to date information. By use of this document you agree that Perkins Engines Company Limited is not responsible for errors or omissions.

NOTICE

These recommendations are subject to change without notice. Contact your local Perkins distributor for the most up to date recommendations.

Diesel Fuel Requirements

Satisfactory engine performance is dependent on the use of a good quality fuel. The use of a good quality fuel will give the following results: long engine life and acceptable exhaust emissions levels. The fuel must meet the minimum requirements that are stated in table 6 .

NOTICE

The footnotes are a key part of the Perkins Specification for Distillate Diesel Fuel Table. Read ALL of the footnotes.

Table 6

Perkins Specification for Distillate Diesel Fuel ⁽¹⁾				
Property	UNITS	Requirements	"ASTM" Test	"ISO" Test
Aromatics	%Volume	35% maximum	D1319	"ISO"3837
Ash	%Weight	0.01% maximum	D482	"ISO"6245
Carbon Residue on 10% Bottoms	%Weight	0.35% maximum	D524	"ISO"4262
Cetane Number ⁽²⁾	-	40 minimum	D613/D6890	"ISO"5165
Cloud Point	°C	The cloud point must not exceed the lowest expected ambient temperature.	D2500	"ISO"3015
Copper Strip Corrosion	-	No. 3 maximum	D130	"ISO"2160
Density at 15 °C (59 °F) ⁽³⁾	Kg / M ³	801 minimum and 876 maximum	No equivalent test	"ISO 3675" "ISO 12185"
Distillation	°C	10% at 282 °C (539.6 °F) maximum 90% at 360 °C (680 °F) maximum	D86	"ISO"3405
Flash Point	°C	legal limit	D93	"ISO"2719
Thermal Stability	-	Minimum of 80% reflectance after aging for 180 minutes at 150 °C (302 °F)	D6468	No equivalent test
Pour Point	°C	6 °C (42.8 °F) minimum below ambient temperature	D97	"ISO"3016
Sulfur ^{(1) (4)}	%mass	1% maximum	D5453/D26222	"ISO 20846" "ISO 20884"
Kinematic Viscosity ⁽⁵⁾	"MM" ² /S (cSt)"	The viscosity of the fuel that is delivered to the fuel injection pump. "1.4 minimum/ 4.5 maximum"	D445	"ISO"3405
Water and sediment	% weight	0.1% maximum	D1796	"ISO"3734
Water	% weight	0.1% maximum	D1744	No equivalent test
Sediment	% weight	0.05% maximum	D473	"ISO"3735
Gums and Resins ⁽⁶⁾	mg/100mL	10 mg per 100 mL maximum	D381	"ISO"6246
Lubricity corrected wear scar diameter at 60 °C (140 °F). ⁽⁷⁾	mm	0.52 maximum	D6079	"ISO"12156-1

(1) This specification includes the requirements for Ultra Low Sulfur Diesel (ULSD). ULSD fuel will have ≤ 15 ppm (0.0015%) sulfur. Refer to "ASTM D5453", "ASTM D2622", or "ISO 20846, ISO 20884" test methods. This specification includes the requirements for Low Sulfur Diesel (LSD). LSD fuel will have ≤ 500 ppm (0.05%) sulfur. Refer to following: "ASTM 5453, ASTM D2622", "ISO 20846" and "ISO 20884 test methods".

(2) A fuel with a higher cetane number is recommended in order to operate at a higher altitude or in cold weather.

(3) "Via standards tables, the equivalent API gravity for the minimum density of 801 kg / m³ (kilograms per cubic meter) is 45 and for the maximum density of 876 kg / m³ is 30".

(4) Regional regulations, national regulations or international regulations can require a fuel with a specific sulfur limit. Consult all applicable regulations before selecting a fuel for a given engine application. Perkins fuel systems and engine components can operate on high sulfur fuels. Fuel sulfur levels affect exhaust emissions. High sulfur fuels also increase the potential for corrosion of internal components. Fuel sulfur levels above 0.5% may significantly shorten the oil change interval. For additional information, refer to this manual, "Fluid recommendations (General lubricant information)".

(continued)

(Table 6, contd)

- (5) The values of the fuel viscosity are the values as the fuel is delivered to the fuel injection pumps. Fuel should also meet the minimum viscosity requirement and the fuel should meet the maximum viscosity requirements at 40 °C (104 °F) of either the "ASTM D445" test method or the "ISO 3104" test method. If a fuel with a low viscosity is used, cooling of the fuel may be required to maintain 1.4 cSt or greater viscosity at the fuel injection pump. Fuels with a high viscosity might require fuel heaters in order to lower the viscosity to 4.5 cSt at the fuel injection pump.
- (6) Follow the test conditions and procedures for gasoline (motor).
- (7) The lubricity of a fuel is a concern with low sulfur and ultra low sulfur fuel. To determine the lubricity of the fuel, use the "ISO 12156-1 or ASTM D6079 High Frequency Reciprocating Rig (HFRR)" test. If the lubricity of a fuel does not meet the minimum requirements, consult your fuel supplier. Do not treat the fuel without consulting the fuel supplier. Some additives are not compatible. These additives can cause problems in the fuel system.

NOTICE

Operating with fuels that do not meet the Perkins recommendations can cause the following effects: Starting difficulty, poor combustion, deposits in the fuel injectors, reduced service life of the fuel system, deposits in the combustion chamber and reduced service life of the engine.

Diesel Fuel Characteristics

Perkins Recommendation

Cetane Number

Fuel that has a high cetane number will give a shorter ignition delay. This will produce a better ignition quality. Cetane numbers are derived for fuels against proportions of cetane and heptamethylnonane in the standard CFR engine. Refer to "ISO 5165" for the test method.

Cetane numbers in excess of 45 are normally expected from current diesel fuel. However, a cetane number of 40 may be experienced in some territories. The United States of America is one of the territories that can have a low cetane value. A minimum cetane value of 40 is required during average starting conditions. A higher cetane value may be required for operations at high altitudes or in cold weather operations.

Fuel with a low cetane number can be the root cause of problems during cold start.

Viscosity

Viscosity is the property of a liquid of offering resistance to shear or flow. Viscosity decreases with increasing temperature. This decrease in viscosity follows a logarithmic relationship for normal fossil fuel. The common reference is to kinematic viscosity. This is the quotient of the dynamic viscosity that is divided by the density. The determination of kinematic viscosity is normally by readings from gravity flow viscometers at standard temperatures. Refer to "ISO 3104" for the test method.

The viscosity of the fuel is significant because fuel serves as a lubricant for the fuel system components. Fuel must have sufficient viscosity in order to lubricate the fuel system in both extremely cold temperatures and extremely hot temperatures. If the kinematic viscosity of the fuel is lower than 1.4 cSt at the fuel injection pump damage to the fuel injection pump can occur. This damage can be excessive scuffing and seizure. Low viscosity may lead to difficult hot restarting, stalling and loss of performance. High viscosity may result in seizure of the pump.

Perkins recommends kinematic viscosities of 1.4 and 4.5 mm²/sec that is delivered to the fuel injection pump.

Density

Density is the mass of the fuel per unit volume at a specific temperature. This parameter has a direct influence on engine performance and a direct influence on emissions. This determines the heat output from a given injected volume of fuel. This is generally quoted in the following kg/m³ at 15 °C (59 °F).

Perkins recommends a value of density of 841 kg/m³ in order to obtain the correct power output. Lighter fuels are acceptable but these fuels will not produce the rated power.

Sulfur

The level of sulfur is governed by emissions legislations. Regional regulation, national regulations or international regulations can require a fuel with a specific sulfur limit. The sulfur content of the fuel and the fuel quality must comply with all existing local regulations for emissions.

By using the test methods “ASTM D5453, ASTM D2622, or ISO 20846 ISO 20884”, the content of sulfur in low sulfur diesel (LSD) fuel must be below 500 PPM 0.05%. By using the test methods “ASTM D5453, ASTM D2622, or ISO 20846 ISO 20884”, the content of sulfur in ultra low sulfur (ULSD) fuel must be below 15 PPM 0.0015%. The use of LSD fuel and the use of ULSD fuel are acceptable provided that the fuels meet the minimum requirements that are stated in table 6 . The lubricity of these fuels must not exceed wear scar diameter of 0.52 mm (0.0205 inch). The fuel lubricity test must be performed on a HFRR, operated at 60 °C (140 °F). Refer to “ISO 12156-1 ”.

In some parts of the world and for some applications, high sulfur fuels above 0.5% by mass might only be available. Fuel with very high sulfur content can cause engine wear. High sulfur fuel will have a negative impact on emissions of particulates. High sulfur fuel can be used provided that the local emissions legislation will allow the use. High sulfur fuel can be used in countries that do not regulate emissions.

When only high sulfur fuels are available, it will be necessary that high alkaline lubricating oil is used in the engine or that the lubricating oil change interval is reduced. Refer to this Operation and Maintenance Manual, “Fluid Recommendations (General Lubrication Information)” for information on sulfur in fuel.

Lubricity

This is the capability of the fuel to prevent pump wear. The fluid's lubricity describes the ability of the fluid to reduce the friction between surfaces that are under load. This ability reduces the damage that is caused by friction. Fuel injection systems rely on the lubricating properties of the fuel. Until fuel sulfur limits were mandated, the fuel's lubricity was generally believed to be a function of fuel viscosity.

The lubricity has particular significance to the current low viscosity fuel, low sulfur fuel and low aromatic fossil fuel. These fuels are made in order to meet stringent exhaust emissions. A test method for measuring the lubricity of diesel fuels has been developed and the test is based on the HFRR method that is operated at 60 °C (140 °F). Refer to “ISO 12156 part 1 and CEC document F06-A-96” for the test method.

Lubricity wear scar diameter of 0.52 mm (0.0205 inch) MUST NOT be exceeded. The fuel lubricity test must be performed on a HFRR, operated at 60 °C (140 °F). Refer to “ISO 12156-1 ”.

Fuel additives can enhance the lubricity of a fuel. Contact your fuel supplier for those circumstances when fuel additives are required. Your fuel supplier can make recommendations for additives to use and for the proper level of treatment.

Distillation

This is an indication of the mixture of different hydrocarbons in the fuel. A high ratio of light weight hydrocarbons can affect the characteristics of combustion.

Classification of the Fuels

Diesel engines have the ability to burn a wide variety of fuels. These fuels are divided into four general groups: Ref to table 7

Table 7

Fuel Groups	Classification	
Group 1	Preferred fuels	Full life of the Product
Group 2	Permissible fuels with an appropriate fuel additive	These fuels MAY cause reduced engine life and performance
Group 3	Permissible fuels with an appropriate fuel additive	These fuels WILL cause reduced engine life and performance
Group 4	Biodiesel	

Group 1 Specifications (Preferred Fuels)

This group of fuel specifications is considered acceptable:

- EN590 DERV Grade A, B, C, E, F, Class, 0, 1, 2, 3 and 4
- “BS2869 Class A2” Off-Highway Gas Oil Red Diesel
- “ASTM D975”, Class 1D and Class 2D
- “JIS K2204 Grades 1,2,3 and Special Grade 3”
This grade of fuel must meet the minimum lubricity requirements that are stated in table 6 .
- 5% FAME to “EN14214” can be mixed with the fuel that meets the requirements that are stated in table 6 . This blend is commonly known as B5.

Note: The use of LSD fuel and the use of ULSD fuel is acceptable provided that the fuels meet the minimum requirements that are stated in table 6 . The lubricity of these fuels must not exceed wear scar diameter of 0.52 mm (0.0205 inch). The lubricity test must be performed on a HFRR, operated at 60 °C (140 °F). Refer to “ISO 12156-1 ”. By using the test methods “ASTM D5453, ASTM D2622, or ISO 20846 ISO 20884”, the content of sulfur in LSD fuel must be below 500 PPM 0.05%. By using the test methods “ASTM D5453, ASTM D2622, or ISO 20846 ISO 20884”, the content of sulfur in ULSD fuel must be below 15 PPM 0.0015%.

Group 2 Specifications (Permissible Fuels)

This group of fuel specifications is considered acceptable, but only with an appropriate fuel additive, but these fuels MAY reduce the engine life and performance.

- “JP7 (MIL-T-38219)”
- “NATO F63”
- JP8
- JP5
- “Jet A1 (ASTM D1655)”
- “Jet A (ASTM D1655)”
- “NATO F34 ”

Note: These fuels are only acceptable provided that these fuels are used with an appropriate fuel additive. These fuels must meet the requirements that are stated in table 6 . Fuel samples should be analyzed for the compliance. These fuels MUST NOT exceed lubricity wear scar diameter of 0.52 mm (0.0205 inch). The fuel lubricity test must be performed on a HFRR, operated at 60 °C (140 °F). Refer to “ISO 12156-1 ”. Fuels must have minimum viscosity of 1.4 centistokes that is delivered to the fuel injection pump. Fuel cooling may be required in order to maintain minimum viscosity of 1.4 centistokes that is delivered to the fuel injection pump.

Group 3 Specifications (Permissible Fuels)

This group of fuel specification must be used only with the appropriate fuel additive. This fuel WILL reduce engine life and performance.

“JIS 2203#1 and #2 Toyu”

Note: These fuels are only acceptable provided that these fuels are used with an appropriate fuel additive. These fuels must meet the requirements that are stated in table 6 . Fuel samples should be analyzed for the compliance. These fuels MUST NOT exceed lubricity wear scar diameter of 0.52 mm (0.0205 inch). The fuel lubricity test must be performed on a HFRR, operated at 60 °C (140 °F). Refer to “ISO 12156-1 ”. Fuels must have minimum viscosity of 1.4 centistokes that is delivered to the fuel injection pump. Fuel cooling may be required in order to maintain minimum viscosity of 1.4 centistokes that is delivered to the fuel injection pump.

Group 4 Biodiesel

Biodiesel is a fuel that can be defined as mono-alkyl esters of fatty acids. Biodiesel is a fuel that can be made from a variety of feedstock. The most commonly available biodiesel in Europe is Rape Methyl Ester (REM). This biodiesel is derived from rapeseed oil. Soy Methyl Ester (SME) is the most common biodiesel in the United States. This biodiesel is derived from soybean oil. Soybean oil or rapeseed oil are the primary feedstocks. These fuels are together known as Fatty Acid Methyl Esters (FAME).

Raw pressed vegetable oils are NOT acceptable for use as a fuel in any concentration in compression engines. Without esterification, these oils gel in the crankcase and the fuel tank. These fuels may not be compatible with many of the elastomers that are used in engines that are manufactured today. In original forms, these oils are not suitable for use as a fuel in compression engines. Alternate base stocks for biodiesel may include animal tallow, waste cooking oils, or a variety of other feedstocks. In order to use any of the products that are listed as fuel, the oil must be esterified.

Note: Engines that are manufactured by Perkins are certified by use of the prescribed Environmental Protection Agency (EPA) and European Certification fuels. Perkins does not certify engines on any other fuel. The user of the engine has the responsibility of using the correct fuel that is recommended by the manufacturer and allowed by the EPA and other appropriate regulatory agencies.

Recommendation for the use of biodiesel

Use of FAME fuels is permissible. However, the following conditions apply:

- The FAME fuel must comply with “EN14214”.
- A maximum of 5% mixture of FAME can be used in mineral oil diesel fuel, provided that the fuel complies with the fuel specification that is listed in table 6 . This blend is commonly known as B5. No mixture above 5% is acceptable. Concentrations above 5% will lead to reduced product service life and potential failure of the fuel injection equipment.

Note: When biodiesel, or any blend of biodiesel is used, the user has the responsibility for obtaining the proper local exemptions, regional exemptions, and/or national exemptions that are required for the use of biodiesel in any Perkins engine that is regulated by emissions standards. Biodiesel that meets EN 14214 is acceptable. The biodiesel must be blended with an acceptable distillate diesel fuel at the maximum stated percentages. However, the following operational recommendations must be followed:

- The oil change interval can be affected by the use of biodiesel. Use Services Oil Analysis in order to monitor the condition of the engine oil. Use Services Oil Analysis also in order to determine the oil change interval that is optimum.
- Confirm that biodiesel is acceptable for use with the manufacturer of the fuel filters.
- In a comparison of distillate fuels to biodiesel, biodiesel provides less energy per gallon by 5% to 7%. Do NOT change the engine rating in order to compensate for the power loss. This will help avoid engine problems when the engine is converted back to 100 percent distillate diesel fuel.
- The compatibility of the elastomers with biodiesel is being monitored. The condition of seals and hoses should be monitored regularly.
- Biodiesel may pose low ambient temperature problems for both storage and operation. At low ambient temperatures, fuel may need to be stored in a heated building or a heated storage tank. The fuel system may require heated fuel lines, filters, and tanks. Filters may plug and fuel in the tank may solidify at low ambient temperatures if precautions are not taken. Consult your biodiesel supplier for assistance in the blending and attainment of the proper cloud point for the fuel.
- Biodiesel has poor oxidation stability, which can result in long term problems in the storage of biodiesel. The poor oxidation stability may accelerate fuel oxidation in the fuel system. This is especially true in engines with electronic fuel systems because these engines operate at higher temperatures. Consult the fuel supplier for oxidation stability additives.
- Biodiesel is a fuel that can be made from a variety of feedstock. The feedstock that is used can affect the performance of the product. Two of the characteristics of the fuel that are affected are cold flow and oxidation stability. Contact your fuel supplier for guidance.
- Biodiesel or biodiesel blends are not recommended for engines that will operate occasionally. This is due to poor oxidation stability. If the user is prepared to accept some risk, then limit biodiesel to a maximum of B5. Examples of applications that should limit the use of biodiesel are the following: Standby Generator sets and certain emergency vehicles
- Biodiesel is an excellent medium for microbial contamination and growth. Microbial contamination and growth can cause corrosion in the fuel system and premature plugging of the fuel filter. The use of conventional anti-microbial additives and the effectiveness of conventional anti-microbial additives in biodiesel is not known. Consult your supplier of fuel and additive for assistance.
- Care must be taken in order to remove water from fuel tanks. Water accelerates microbial contamination and growth. When biodiesel is compared to distillate fuels, water is naturally more likely to exist in the biodiesel.

Fuel for Cold Weather Operation

The European standard "EN590" contains climate dependant requirements and a range of options. The options can be applied differently in each country. There are 5 classes that are given to arctic climates and severe winter climates. 0, 1, 2, 3 and 4.

Fuel that complies with "EN590" CLASS 4 can be used at temperatures as low as $-44\text{ }^{\circ}\text{C}$ ($-47.2\text{ }^{\circ}\text{F}$). Refer to "EN590" for a detailed discretion of the physical properties of the fuel.

The diesel fuel "ASTM D975 1-D" that is used in the united states of america may be used in very cold temperatures that are below $-18\text{ }^{\circ}\text{C}$ ($-0.4\text{ }^{\circ}\text{F}$).

In extreme cold ambient conditions, you may also use fuels that are listed in the table 8 . These fuels are intended to be used in temperatures that can be as low as $-54\text{ }^{\circ}\text{C}$ ($-65.2\text{ }^{\circ}\text{F}$).

Table 8

Light Distillate Fuels ⁽¹⁾	
Specification	Grade
"MIL-T-5624R"	JP-5
"MIL-T-83133D"	JP-8
"ASTM D1655"	Jet-A-1

(1) The use of these fuels is acceptable with an appropriate fuel additive and the fuels must meet minimum requirements that are stated in Table 6 . Fuel samples should be analyzed for the compliance. Fuels MUST NOT exceed 0.52 mm lubricity wear scar diameter that is tested on a HFFR . The test must be performed at $60\text{ }^{\circ}\text{C}$. Refer to "ISO 12156-1". Fuels must have minimum viscosity of 1.4 centistokes that is delivered to the fuel injection pump. Fuel cooling may be required in order to maintain minimum viscosity of 1.4 centistokes that is delivered to the fuel injection pump.

WARNING

Mixing alcohol or gasoline with diesel fuel can produce an explosive mixture in the engine crankcase or the fuel tank. Alcohol or gasoline must not be used in order to dilute diesel fuel. Failure to follow this instruction may result in death or personal injury.

There are many other diesel fuel specifications that are published by governments and by technological societies. Usually, those specifications do not review all the requirements that are addressed in table 6 . To ensure optimum engine performance, a complete fuel analysis should be obtained before engine operation. The fuel analysis should include all of the properties that are stated in the table 6 .

Fuel Additive

Supplemental diesel fuel additives are not generally recommended. This is due to potential damage to the fuel system or the engine. Your fuel supplier or the fuel manufacturer will add the appropriate supplemental diesel fuel additives.

Perkins recognizes the fact that additives may be required in some special circumstances. Fuel additives need to be used with caution. Contact your fuel supplier for those circumstances when fuel additives are required. Your fuel supplier can recommend the appropriate fuel additive and the correct level of treatment.

Note: For the best results, your fuel supplier should treat the fuel when additives are required. The treated fuel must meet the requirements that are stated in table 6 .

i02865363

Fluid Recommendations**General Lubricant Information**

Because of government regulations regarding the certification of exhaust emissions from the engine, the lubricant recommendations must be followed.

- EMA _____ Engine Manufacturers Association
- API _____ American Petroleum Institute
- SAE _____ Society Of Automotive Engineers Inc.

EMA Guidelines

The "Engine Manufacturers Association Recommended Guideline on Diesel Engine Oil" is recognized by Perkins. For detailed information about this guideline, see the latest edition of EMA publication, "EMA DHD -1".

API Licensing

The Engine Oil Licensing and Certification System by the American Petroleum Institute (API) is recognized by Perkins. For detailed information about this system, see the latest edition of the "API publication No. 1509". Engine oils that bear the API symbol are authorized by API.

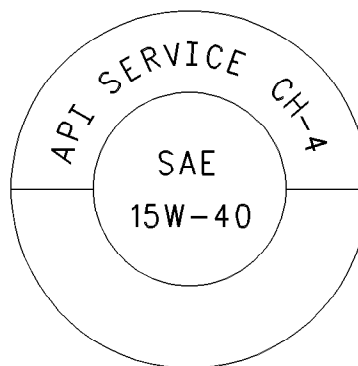

Illustration 29

g00546535

Typical API symbol

Terminology

Certain abbreviations follow the nomenclature of "SAE J754". Some classifications follow "SAE J183" abbreviations, and some classifications follow the "EMA Recommended Guideline on Diesel Engine Oil". In addition to Perkins definitions, there are other definitions that will be of assistance in purchasing lubricants. Recommended oil viscosities can be found in this publication, "Fluid Recommendations/ Engine Oil" topic (Maintenance Section).

Engine Oil**Commercial Oils****NOTICE**

For applications above 168 kW CI-4 oil must be used.

Table 9

API Classifications for the 1104D Industrial Engine	
Oil Specification	Maintenance Interval

(continued)

(Table 9, contd)

CH-4/CI-4	500 Hours
CI-4	500 Hours
CG-4	250 Hours

Maintenance intervals for engines that use biodiesel – The oil change interval can be adversely affected by the use of biodiesel. Use oil analysis in order to monitor the condition of the engine oil. Use oil analysis also in order to determine the oil change interval that is optimum.

Note: These engine oils are not approved by Perkins and these engine oils must not be used: CC, CD, CD-2 and CF-4.

The performance of commercial diesel engine oils is based on API classifications. These API classifications are developed in order to provide commercial lubricants for a broad range of diesel engines that operate at various conditions.

Only use commercial oils that meet the following classifications:

- API _____ CH-4 CI-4

In order to make the correct choice of a commercial oil, refer to the following explanations:

EMA DHD-1 – The EMA has developed lubricant recommendations as an alternative to the API oil classification system. DHD-1 is a Recommended Guideline that defines a level of oil performance for these types of diesel engines: high speed, four stroke cycle, heavy-duty and light duty. DHD-1 oils may be used in Perkins engines when the following oils are recommended: API CH-4 and API CG-4. DHD-1 oils are intended to provide superior performance in comparison to API CG-4.

DHD-1 oils will meet the needs of high performance Perkins diesel engines that are operating in many applications. The tests and the test limits that are used to define DHD-1 are similar to the new API CH-4 classification. Therefore, these oils will also meet the requirements for diesel engines that require low emissions. DHD-1 oils are designed to control the harmful effects of soot with improved wear resistance and improved resistance to plugging of the oil filter. These oils will also provide superior piston deposit control for engines with either two-piece steel pistons or aluminum pistons.

All DHD-1 oils must complete a full test program with the base stock and with the viscosity grade of the finished commercial oil. The use of “API Base Oil Interchange Guidelines” are not appropriate for DHD-1 oils. This feature reduces the variation in performance that can occur when base stocks are changed in commercial oil formulations.

DHD-1 oils are recommended for use in extended oil change interval programs that optimize the life of the oil. These oil change interval programs are based on oil analysis. DHD-1 oils are recommended for conditions that demand a premium oil. Your Perkins distributor has the specific guidelines for optimizing oil change intervals.

API CH-4 – API CH-4 oils were developed in order to meet the requirements of the new high performance diesel engines. Also, the oil was designed to meet the requirements of the low emissions diesel engines. API CH-4 oils are also acceptable for use in older diesel engines and in diesel engines that use high sulfur diesel fuel. API CH-4 oils may be used in Perkins engines that use API CG-4 and API CF-4 oils. API CH-4 oils will generally exceed the performance of API CG-4 oils in the following criteria: deposits on pistons, control of oil consumption, wear of piston rings, valve train wear, viscosity control and corrosion.

Three new engine tests were developed for the API CH-4 oil. The first test specifically evaluates deposits on pistons for engines with the two-piece steel piston. This test (piston deposit) also measures the control of oil consumption. A second test is conducted with moderate oil soot. The second test measures the following criteria: wear of piston rings, wear of cylinder liners and resistance to corrosion. A third new test measures the following characteristics with high levels of soot in the oil: wear of the valve train, resistance of the oil in plugging the oil filter and control of sludge.

In addition to the new tests, API CH-4 oils have tougher limits for viscosity control in applications that generate high soot. The oils also have improved oxidation resistance. API CH-4 oils must pass an additional test (piston deposit) for engines that use aluminum pistons (single piece). Oil performance is also established for engines that operate in areas with high sulfur diesel fuel.

All of these improvements allow the API CH-4 oil to achieve optimum oil change intervals. API CH-4 oils are recommended for use in extended oil change intervals. API CH-4 oils are recommended for conditions that demand a premium oil. Your Perkins distributor has specific guidelines for optimizing oil change intervals.

Some commercial oils that meet the API classifications may require reduced oil change intervals. To determine the oil change interval, closely monitor the condition of the oil and perform a wear metal analysis.

NOTICE

Failure to follow these oil recommendations can cause shortened engine service life due to deposits and/or excessive wear.

Total Base Number (TBN) and Fuel Sulfur Levels for Direct Injection (DI) Diesel Engines

The Total Base Number (TBN) for an oil depends on the fuel sulfur level. For direct injection engines that use distillate fuel, the minimum TBN of the new oil must be 10 times the fuel sulfur level. The TBN is defined by "ASTM D2896". The minimum TBN of the oil is 5 regardless of fuel sulfur level. Illustration 30 demonstrates the TBN.

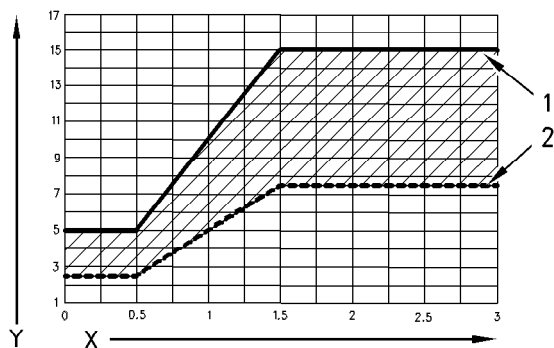

Illustration 30

g00799818

(Y) TBN by "ASTM D2896"

(X) Percentage of fuel sulfur by weight

(1) TBN of new oil

(2) Change the oil when the TBN deteriorates to 50 percent of the original TBN.

Use the following guidelines for fuel sulfur levels that exceed 1.5 percent:

- Choose an oil with the highest TBN that meets one of these classifications: EMA DHD-1 and API CH-4.
- Reduce the oil change interval. Base the oil change interval on the oil analysis. Ensure that the oil analysis includes the condition of the oil and a wear metal analysis.

Excessive piston deposits can be produced by an oil with a high TBN. These deposits can lead to a loss of control of the oil consumption and to the polishing of the cylinder bore.

NOTICE

Operating Direct Injection (DI) diesel engines with fuel sulphur levels over 0.5 percent will require shortened oil change intervals in order to help maintain adequate wear protection.

Table 10

Percentage of Sulfur in the fuel	Oil change interval
Lower than 0.5	Normal
0.5 to 1.0	0.75 of normal
Greater than 1.0	0.50 of normal

Lubricant Viscosity Recommendations for Direct Injection (DI) Diesel Engines

The correct SAE viscosity grade of oil is determined by the minimum ambient temperature during cold engine start-up, and the maximum ambient temperature during engine operation.

Refer to Table 11 (minimum temperature) in order to determine the required oil viscosity for starting a cold engine.

Refer to Table 11 (maximum temperature) in order to select the oil viscosity for engine operation at the highest ambient temperature that is anticipated.

Generally, use the highest oil viscosity that is available to meet the requirement for the temperature at start-up.

Table 11

EMA LRG-1 API CH-4 Viscosity Grade	Engine Oil Viscosity	
	Ambient Temperature	
	Minimum	Maximum
SAE 0W20	-40 °C (-40 °F)	10 °C (50 °F)
SAE 0W30	-40 °C (-40 °F)	30 °C (86 °F)
SAE 0W40	-40 °C (-40 °F)	40 °C (104 °F)
SAE 5W30	-30 °C (-22 °F)	30 °C (86 °F)
SAE 5W40	-30 °C (-22 °F)	40 °C (104 °F)
SAE 10W30	-20 °C (-4 °F)	40 °C (104 °F)
SAE 15W40	-10 °C (14 °F)	50 °C (122 °F)

Synthetic Base Stock Oils

Synthetic base oils are acceptable for use in these engines if these oils meet the performance requirements that are specified for the engine.

Synthetic base oils generally perform better than conventional oils in the following two areas:

- Synthetic base oils have improved flow at low temperatures especially in arctic conditions.
- Synthetic base oils have improved oxidation stability especially at high operating temperatures.

Some synthetic base oils have performance characteristics that enhance the service life of the oil. Perkins does not recommend the automatic extending of the oil change intervals for any type of oil.

Re-refined Base Stock Oils

Re-refined base stock oils are acceptable for use in Perkins engines if these oils meet the performance requirements that are specified by Perkins. Re-refined base stock oils can be used exclusively in finished oil or in a combination with new base stock oils. The specification for the US military and the specifications of other heavy equipment manufacturers also allow the use of re-refined base stock oils that meet the same criteria.

The process that is used to make re-refined base stock oil should adequately remove all wear metals that are in the used oil and all the additives that are in the used oil. The process that is used to make re-refined base stock oil generally involves the process of vacuum distillation and hydrotreating the used oil. Filtering is adequate for the production of high quality, re-refined base stock oil.

Lubricants for Cold Weather

When an engine is started and an engine is operated in ambient temperatures below -20°C (-4°F), use multigrade oils that are capable of flowing in low temperatures.

These oils have lubricant viscosity grades of SAE 0W or SAE 5W.

When an engine is started and operated in ambient temperatures below -30°C (-22°F), use a synthetic base stock multigrade oil with an 0W viscosity grade or with a 5W viscosity grade. Use an oil with a pour point that is lower than -50°C (-58°F).

Perkins recommends the following lubricants for use in cold weather conditions:

Use a commercial oil that is API:CI-4, CI-4 PLUS, CH-4 and CG-4. The oil must have one of the following lubricant viscosity grades: SAE 0W-20, SAE 0W-30, SAE 0W-40, SAE 5W-30 and SAE 5W-40

Aftermarket Oil Additives

Perkins does not recommend the use of aftermarket additives in oil. It is not necessary to use aftermarket additives in order to achieve the engine's maximum service life or rated performance. Fully formulated, finished oils consist of base oils and of commercial additive packages. These additive packages are blended into the base oils at precise percentages in order to help provide finished oils with performance characteristics that meet industry standards.

There are no industry standard tests that evaluate the performance or the compatibility of aftermarket additives in finished oil. Aftermarket additives may not be compatible with the finished oil's additive package, which could lower the performance of the finished oil. The aftermarket additive could fail to mix with the finished oil. This could produce sludge in the crankcase. Perkins discourages the use of aftermarket additives in finished oils.

To achieve the best performance from a Perkins engine, conform to the following guidelines:

- Select the correct oil, or a commercial oil that meets the "EMA Recommended Guideline on Diesel Engine Oil" or the recommended API classification.
- See the appropriate "Lubricant Viscosities" table in order to find the correct oil viscosity grade for your engine.
- At the specified interval, service the engine. Use new oil and install a new oil filter.
- Perform maintenance at the intervals that are specified in the Operation and Maintenance Manual, "Maintenance Interval Schedule".

Oil analysis

Some engines may be equipped with an oil sampling valve. If oil analysis is required the oil sampling valve is used to obtain samples of the engine oil. The oil analysis will complement the preventive maintenance program.

The oil analysis is a diagnostic tool that is used to determine oil performance and component wear rates. Contamination can be identified and measured through the use of the oil analysis. The oil analysis includes the following tests:

- The Wear Rate Analysis monitors the wear of the engine's metals. The amount of wear metal and type of wear metal that is in the oil is analyzed. The increase in the rate of engine wear metal in the oil is as important as the quantity of engine wear metal in the oil.
- Tests are conducted in order to detect contamination of the oil by water, glycol or fuel.

- The Oil Condition Analysis determines the loss of the oil's lubricating properties. An infrared analysis is used to compare the properties of new oil to the properties of the used oil sample. This analysis allows technicians to determine the amount of deterioration of the oil during use. This analysis also allows technicians to verify the performance of the oil according to the specification during the entire oil change interval.

i02962446

Fluid Recommendations (Coolant Specifications)

General Coolant Information

NOTICE

Never add coolant to an overheated engine. Engine damage could result. Allow the engine to cool first.

NOTICE

If the engine is to be stored in, or shipped to an area with below freezing temperatures, the cooling system must be either protected to the lowest outside temperature or drained completely to prevent damage.

NOTICE

Frequently check the specific gravity of the coolant for proper freeze protection or for anti-boil protection.

Clean the cooling system for the following reasons:

- Contamination of the cooling system
 - Overheating of the engine
 - Foaming of the coolant
-

NOTICE

Never operate an engine without water temperature regulators in the cooling system. Water temperature regulators help to maintain the engine coolant at the proper operating temperature. Cooling system problems can develop without water temperature regulators.

Many engine failures are related to the cooling system. The following problems are related to cooling system failures: Overheating, leakage of the water pump and plugged radiators or heat exchangers.

These failures can be avoided with correct cooling system maintenance. Cooling system maintenance is as important as maintenance of the fuel system and the lubrication system. Quality of the coolant is as important as the quality of the fuel and the lubricating oil.

Coolant is normally composed of three elements: Water, additives and glycol.

Water

Water is used in the cooling system in order to transfer heat.

Distilled water or deionized water is recommended for use in engine cooling systems.

DO NOT use the following types of water in cooling systems: Hard water, softened water that has been conditioned with salt and sea water.

If distilled water or deionized water is not available, use water with the properties that are listed in Table 12 .

Table 12

Acceptable Water	
Property	Maximum Limit
Chloride (Cl)	40 mg/L
Sulfate (SO ₄)	100 mg/L
Total Hardness	170 mg/L
Total Solids	340 mg/L
Acidity	pH of 5.5 to 9.0

For a water analysis, consult one of the following sources:

- Local water utility company
- Agricultural agent
- Independent laboratory

Additives

Additives help to protect the metal surfaces of the cooling system. A lack of coolant additives or insufficient amounts of additives enable the following conditions to occur:

- Corrosion
- Formation of mineral deposits
- Rust
- Scale
- Foaming of the coolant

Many additives are depleted during engine operation. These additives must be replaced periodically.

Additives must be added at the correct concentration. Overconcentration of additives can cause the inhibitors to drop out-of-solution. The deposits can enable the following problems to occur:

- Formation of gel compounds
- Reduction of heat transfer
- Leakage of the water pump seal
- Plugging of radiators, coolers, and small passages

Glycol

Glycol in the coolant helps to provide protection against the following conditions:

- Boiling
- Freezing
- Cavitation of the water pump

For optimum performance, Perkins recommends a 1:1 mixture of a water/glycol solution.

Note: Use a mixture that will provide protection against the lowest ambient temperature.

Note: 100 percent pure glycol will freeze at a temperature of -23°C (-9°F).

Most conventional antifreezes use ethylene glycol. Propylene glycol may also be used. In a 1:1 mixture with water, ethylene and propylene glycol provide similar protection against freezing and boiling. See Tables 13 and 14.

Table 13

Ethylene Glycol	
Concentration	Freeze Protection
50 Percent	-36°C (-33°F)
60 Percent	-51°C (-60°F)

NOTICE

Do not use propylene glycol in concentrations that exceed 50 percent glycol because of propylene glycol's reduced heat transfer capability. Use ethylene glycol in conditions that require additional protection against boiling or freezing.

Table 14

Propylene Glycol	
Concentration	Freeze Protection
50 Percent	-29°C (-20°F)

To check the concentration of glycol in the coolant, measure the specific gravity of the coolant.

Coolant Recommendations

- ELC _____ Extended Life Coolant
- SCA _____ Supplement Coolant Additive
- ASTM _____ American Society for Testing and Materials

The following two coolants are used in Perkins diesel engines:

Preferred – Perkins ELC

Acceptable – A commercial heavy-duty antifreeze that meets “ASTM D4985” specifications

NOTICE

Do not use a commercial coolant/antifreeze that only meets the ASTM D3306 specification. This type of coolant/antifreeze is made for light automotive applications.

Perkins recommends a 1:1 mixture of water and glycol. This mixture of water and glycol will provide optimum heavy-duty performance as a antifreeze. This ratio may be increased to 1:2 water to glycol if extra freezing protection is required.

Note: A commercial heavy-duty antifreeze that meets “ASTM D4985” specifications MAY require a treatment with an SCA at the initial fill. Read the label or the instructions that are provided by the OEM of the product.

In stationary engine applications and marine engine applications that do not require anti-boil protection or freeze protection, a mixture of SCA and water is acceptable. Perkins recommends a six percent to eight percent concentration of SCA in those cooling systems. Distilled water or deionized water is preferred. Water which has the recommended properties may be used.

Table 15

Coolant Service Life	
Coolant Type	Service Life
Perkins ELC	6,000 Service Hours or Three Years
Commercial Heavy-Duty Antifreeze that meets “ASTM D4985”	3000 Service Hours or Two Years
Perkins POWERPART SCA	3000 Service Hours or Two Years
Commercial SCA and Water	3000 Service Hours or Two Years

ELC

Perkins provides ELC for use in the following applications:

- Heavy-duty spark ignited gas engines
- Heavy-duty diesel engines
- Automotive applications

The anti-corrosion package for ELC is different from the anti-corrosion package for other coolants. ELC is an ethylene glycol base coolant. However, ELC contains organic corrosion inhibitors and antifoam agents with low amounts of nitrite. Perkins ELC has been formulated with the correct amount of these additives in order to provide superior corrosion protection for all metals in engine cooling systems.

ELC is available in a premixed cooling solution with distilled water. ELC is a 1:1 mixture. The Premixed ELC provides freeze protection to -36°C (-33°F). The Premixed ELC is recommended for the initial fill of the cooling system. The Premixed ELC is also recommended for topping off the cooling system.

Containers of several sizes are available. Consult your Perkins distributor for the part numbers.

ELC Cooling System Maintenance

Correct additions to the Extended Life Coolant

NOTICE

Use only Perkins products for pre-mixed or concentrated coolants.

Mixing Extended Life Coolant with other products reduces the Extended Life Coolant service life. Failure to follow the recommendations can reduce cooling system components life unless appropriate corrective action is performed.

In order to maintain the correct balance between the antifreeze and the additives, you must maintain the recommended concentration of ELC. Lowering the proportion of antifreeze lowers the proportion of additive. This will lower the ability of the coolant to protect the system from pitting, from cavitation, from erosion, and from deposits.

NOTICE

Do not use a conventional coolant to top-off a cooling system that is filled with Extended Life Coolant (ELC).

Do not use standard supplemental coolant additive (SCA).

When using Perkins ELC, do not use standard SCA's or SCA filters.

ELC Cooling System Cleaning

Note: If the cooling system is already using ELC, cleaning agents are not required to be used at the specified coolant change interval. Cleaning agents are only required if the system has been contaminated by the addition of some other type of coolant or by cooling system damage.

Clean water is the only cleaning agent that is required when ELC is drained from the cooling system.

Before the cooling system is filled, the heater control (if equipped) must be set to the HOT position. Refer to the OEM in order to set the heater control. After the cooling system is drained and the cooling system is refilled, operate the engine until the coolant level reaches the normal operating temperature and until the coolant level stabilizes. As needed, add the coolant mixture in order to fill the system to the specified level.

Changing to Perkins ELC

To change from heavy-duty antifreeze to the Perkins ELC, perform the following steps:

NOTICE

Care must be taken to ensure that all fluids are contained during performance of inspection, maintenance, testing, adjusting and the repair of the product. Be prepared to collect the fluid with suitable containers before opening any compartment or disassembling any component containing fluids.

Dispose of all fluids according to local regulations and mandates.

1. Drain the coolant into a suitable container.
2. Dispose of the coolant according to local regulations.
3. Flush the system with clean water in order to remove any debris.
4. Use Perkins cleaner to clean the system. Follow the instruction on the label.
5. Drain the cleaner into a suitable container. Flush the cooling system with clean water.
6. Fill the cooling system with clean water and operate the engine until the engine is warmed to 49° to 66°C (120° to 150°F).

NOTICE

Incorrect or incomplete flushing of the cooling system can result in damage to copper and other metal components.

To avoid damage to the cooling system, make sure to completely flush the cooling system with clear water. Continue to flush the system until all the signs of the cleaning agent are gone.

7. Drain the cooling system into a suitable container and flush the cooling system with clean water.

Note: The cooling system cleaner must be thoroughly flushed from the cooling system. Cooling system cleaner that is left in the system will contaminate the coolant. The cleaner may also corrode the cooling system.

8. Repeat Steps 6 and 7 until the system is completely clean.
9. Fill the cooling system with the Perkins Premixed ELC.

ELC Cooling System Contamination

NOTICE

Mixing ELC with other products reduces the effectiveness of the ELC and shortens the ELC service life. Use only Perkins Products for premixed or concentrate coolants. Failure to follow these recommendations can result in shortened cooling system component life.

ELC cooling systems can withstand contamination to a maximum of ten percent of conventional heavy-duty antifreeze or SCA. If the contamination exceeds ten percent of the total system capacity, perform ONE of the following procedures:

- Drain the cooling system into a suitable container. Dispose of the coolant according to local regulations. Flush the system with clean water. Fill the system with the Perkins ELC.
- Drain a portion of the cooling system into a suitable container according to local regulations. Then, fill the cooling system with premixed ELC. This should lower the contamination to less than 10 percent.
- Maintain the system as a conventional Heavy-Duty Coolant. Treat the system with an SCA. Change the coolant at the interval that is recommended for the conventional Heavy-Duty Coolant.

Commercial Heavy-Duty Antifreeze and SCA

NOTICE

Commercial Heavy-Duty Coolant which contains Amine as part of the corrosion protection system must not be used.

NOTICE

Never operate an engine without water temperature regulators in the cooling system. Water temperature regulators help to maintain the engine coolant at the correct operating temperature. Cooling system problems can develop without water temperature regulators.

Check the antifreeze (glycol concentration) in order to ensure adequate protection against boiling or freezing. Perkins recommends the use of a refractometer for checking the glycol concentration.

Perkins engine cooling systems should be tested at 500 hour intervals for the concentration of SCA.

Additions of SCA are based on the results of the test. An SCA that is liquid may be needed at 500 hour intervals.

Refer to Table 16 for part numbers and for quantities of SCA.

Table 16

Perkins Liquid SCA	
Part Number	Quantity
21825735	10

Adding the SCA to Heavy-Duty Coolant at the Initial Fill

Commercial heavy-duty antifreeze that meets “ASTM D4985” specifications MAY require an addition of SCA at the initial fill. Read the label or the instructions that are provided by the OEM of the product.

Use the equation that is in Table 17 to determine the amount of Perkins SCA that is required when the cooling system is initially filled.

Table 17

Equation For Adding The SCA To The Heavy-Duty Coolant At The Initial Fill
$V \times 0.045 = X$
V is the total volume of the cooling system.
X is the amount of SCA that is required.

Table 18 is an example for using the equation that is in Table 17 .

Table 18

Example Of The Equation For Adding The SCA To The Heavy-Duty Coolant At The Initial Fill		
Total Volume of the Cooling System (V)	Multiplication Factor	Amount of SCA that is Required (X)
15 L (4 US gal)	× 0.045	0.7 L (24 oz)

Adding The SCA to The Heavy-Duty Coolant For Maintenance

Heavy-duty antifreeze of all types REQUIRE periodic additions of an SCA.

Test the antifreeze periodically for the concentration of SCA. For the interval, refer to the Operation and Maintenance Manual, "Maintenance Interval Schedule" (Maintenance Section). Test the concentration of SCA.

Additions of SCA are based on the results of the test. The size of the cooling system determines the amount of SCA that is needed.

Use the equation that is in Table 19 to determine the amount of Perkins SCA that is required, if necessary:

Table 19

Equation For Adding The SCA To The Heavy-Duty Coolant For Maintenance
$V \times 0.014 = X$
V is the total volume of the cooling system.
X is the amount of SCA that is required.

Table 20 is an example for using the equation that is in Table 19 .

Table 20

Example Of The Equation For Adding The SCA To The Heavy-Duty Coolant For Maintenance		
Total Volume of the Cooling System (V)	Multiplication Factor	Amount of SCA that is Required (X)
15 L (4 US gal)	× 0.014	0.2 L (7 oz)

Cleaning the System of Heavy-Duty Antifreeze

Perkins cooling system cleaners are designed to clean the cooling system of harmful scale and corrosion. Perkins cooling system cleaners dissolve mineral scale, corrosion products, light oil contamination and sludge.

- Clean the cooling system after used coolant is drained or before the cooling system is filled with new coolant.
- Clean the cooling system whenever the coolant is contaminated or whenever the coolant is foaming.

Maintenance Recommendations

i04103075

Welding on Engines with Electronic Controls

NOTICE

Because the strength of the frame may decrease, some manufacturers do not recommend welding onto a chassis frame or rail. Consult the OEM of the equipment or your Caterpillar dealer regarding welding on a chassis frame or rail.

Proper welding procedures are necessary in order to avoid damage to the engines ECM, sensors, and associated components. When possible, remove the component from the unit and then weld the component. If removal of the component is not possible, the following procedure must be followed when you weld on a unit equipped with an Electronic Engine. The following procedure is considered to be the safest procedure to weld on a component. This procedure should provide a minimum risk of damage to electronic components.

NOTICE

Do not ground the welder to electrical components such as the ECM or sensors. Improper grounding can cause damage to the drive train bearings, hydraulic components, electrical components, and other components.

Clamp the ground cable from the welder to the component that will be welded. Place the clamp as close as possible to the weld. This will help reduce the possibility of damage.

Note: Perform the welding in areas that are free from explosive hazards.

1. Stop the engine. Turn the switched power to the OFF position.
2. Ensure that the fuel supply to the engine is turned off.
3. Disconnect the negative battery cable from the battery. If a battery disconnect switch is provided, open the switch.
4. Disconnect all electronic components from the wiring harnesses. Include the following components:
 - Electronic components for the driven equipment

- ECM
- Sensors
- Electronically controlled valves
- Relays
- Aftertreatment ID module

NOTICE

Do not use electrical components (ECM or ECM sensors) or electronic component grounding points for grounding the welder.

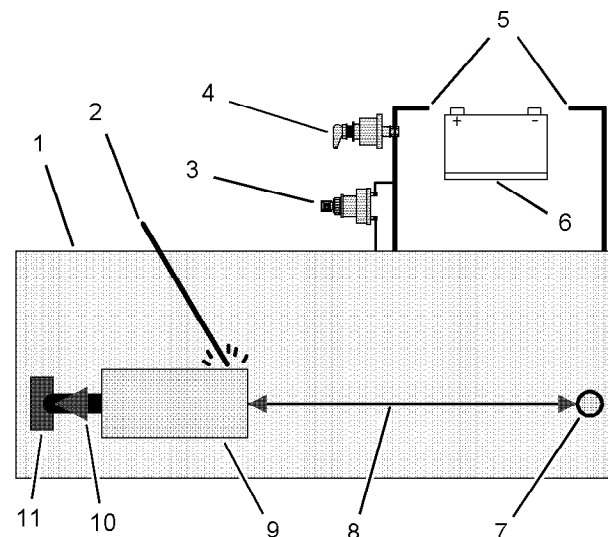

Illustration 31

g01075639

Use the example above. The current flow from the welder to the ground clamp of the welder will not damage any associated components.

- (1) Engine
- (2) Welding electrode
- (3) Keyswitch in the OFF position
- (4) Battery disconnect switch in the open position
- (5) Disconnected battery cables
- (6) Battery
- (7) Electrical/Electronic component
- (8) Minimum distance between the component that is being welded and any electrical/electronic component
- (9) The component that is being welded
- (10) Current path of the welder
- (11) Ground clamp for the welder

5. Connect the welding ground cable directly to the part that will be welded. Place the ground cable as close as possible to the weld in order to reduce the possibility of welding current damage to the following components. Bearings, hydraulic components, electrical components, and ground straps.

Note: If electrical/electronic components are used as a ground for the welder, or electrical/electronic components are located between the welder ground and the weld, current flow from the welder could severely damage the component.

6. Protect the wiring harness from welding debris and spatter.
7. Use standard welding practices to weld the materials.

i08335544

Maintenance Interval Schedule

When Required

“ Battery - Replace”	72
“ Battery or Battery Cable - Disconnect”	73
“ Engine - Clean”	80
“ Engine Air Cleaner Element (Dual Element) - Clean/Replace”	81
“ Engine Oil Sample - Obtain”	85
“ Fuel System - Prime”	90
“ Severe Service Application - Check”	100

Daily

“ Alternator Belt - Inspect/Adjust/Replace”	72
“ Cooling System Coolant Level - Check”	78
“ Driven Equipment - Check”	80
“ Engine Air Cleaner Service Indicator - Inspect”	83
“ Engine Air Precleaner - Check/Clean”	84
“ Engine Oil Level - Check”	84
“ Fuel System Primary Filter/Water Separator - Drain”	95
“ V-Belts - Inspect/Adjust/Replace”	102
“ Walk-Around Inspection”	103

Every 50 Service Hours or Weekly

“ Fuel Tank Water and Sediment - Drain”	98
---	----

Every 250 Service Hours

“ Engine Oil and Filter - Change”	88
-----------------------------------	----

Initial 500 Service Hours

“ Engine Valve Lash - Inspect/Adjust”	88
---------------------------------------	----

Every 500 Service Hours

“ Fan Clearance - Check”	89
--------------------------	----

“ V-Belts - Inspect/Adjust/Replace”	102
-------------------------------------	-----

Every 500 Service Hours or 1 Year

“ Battery Electrolyte Level - Check”	73
“ Cooling System Supplemental Coolant Additive (SCA) - Test/Add”	79
“ Crankcase Breather (Canister) - Replace”	80
“ Engine Air Cleaner Element (Dual Element) - Clean/Replace”	81
“ Engine Oil and Filter - Change”	85
“ Fuel System Primary Filter (Water Separator) Element - Replace”	91
“ Fuel System Secondary Filter - Replace”	96
“ Hoses and Clamps - Inspect/Replace”	99
“ Radiator - Clean”	100

Every 1000 Service Hours

“ Engine Valve Lash - Inspect/Adjust”	88
---------------------------------------	----

Every 2000 Service Hours

“ Aftercooler Core - Inspect”	71
“ Alternator - Inspect”	72
“ Belt Tensioner - Inspect”	74
“ Engine Mounts - Inspect”	84
“ Exhaust Manifold - Inspect”	89
“ Starting Motor - Inspect”	101
“ Turbocharger - Inspect”	101

“ Water Pump - Inspect“ 105

Every 3000 Service Hours

“ Alternator Belt - Inspect/Adjust/Replace“ 72

Every 3000 Service Hours or 2 Years

“ Cooling System Coolant (Commercial Heavy-Duty) - Change“ 74

Every 4000 Service Hours

“ Aftercooler Core - Clean/Test“ 71

Every 12 000 Service Hours or 6 Years

“ Cooling System Coolant (ELC) - Change“ 76

Commissioning

“ Fan Clearance - Check“ 89

i0232260

Aftercooler Core - Clean/Test

1. Remove the core. Refer to the OEM information for the correct procedure.
2. Turn the aftercooler core upside-down in order to remove debris.

WARNING

Personal injury can result from air pressure.

Personal injury can result without following proper procedure. When using pressure air, wear a protective face shield and protective clothing.

Maximum air pressure at the nozzle must be less than 205 kPa (30 psi) for cleaning purposes.

3. Pressurized air is the preferred method for removing loose debris. Direct the air in the opposite direction of the fan's air flow. Hold the nozzle approximately 6 mm (.25 inch) away from the fins. Slowly move the air nozzle in a direction that is parallel with the tubes. This will remove debris that is between the tubes.
4. Pressurized water may also be used for cleaning. The maximum water pressure for cleaning purposes must be less than 275 kPa (40 psi). Use pressurized water in order to soften mud. Clean the core from both sides.

NOTICE

Do not use a high concentration of caustic cleaner to clean the core. A high concentration of caustic cleaner can attack the internal metals of the core and cause leakage. Only use the recommended concentration of cleaner.

5. Back flush the core with a suitable cleaner.
6. Steam clean the core in order to remove any residue. Flush the fins of the aftercooler core. Remove any other trapped debris.
7. Wash the core with hot, soapy water. Rinse the core thoroughly with clean water.

WARNING

Personal injury can result from air pressure.

Personal injury can result without following proper procedure. When using pressure air, wear a protective face shield and protective clothing.

Maximum air pressure at the nozzle must be less than 205 kPa (30 psi) for cleaning purposes.

8. Dry the core with compressed air. Direct the air in the reverse direction of the normal flow.
9. Inspect the core in order to ensure cleanliness. Pressure test the core. If necessary, repair the core.
10. Install the core. Refer to the OEM information for the correct procedure.
11. After cleaning, start the engine and accelerate the engine to high idle rpm. This will help in the removal of debris and drying of the core. Stop the engine. Use a light bulb behind the core in order to inspect the core for cleanliness. Repeat the cleaning, if necessary.

i0232295

Aftercooler Core - Inspect

Note: Adjust the frequency of cleaning according to the effects of the operating environment.

Inspect the aftercooler for these items: damaged fins, corrosion, dirt, grease, insects, leaves, oil and other debris. Clean the aftercooler, if necessary.

For air-to-air aftercoolers, use the same methods that are used for cleaning radiators.

WARNING

Personal injury can result from air pressure.

Personal injury can result without following proper procedure. When using pressure air, wear a protective face shield and protective clothing.

Maximum air pressure at the nozzle must be less than 205 kPa (30 psi) for cleaning purposes.

After cleaning, start the engine and accelerate the engine to high idle rpm. This will help in the removal of debris and drying of the core. Stop the engine. Use a light bulb behind the core in order to inspect the core for cleanliness. Repeat the cleaning, if necessary.

Inspect the fins for damage. Bent fins may be opened with a "comb".

Note: If parts of the aftercooler system are repaired or replaced, a leak test is highly recommended.

Inspect these items for good condition: Welds, mounting brackets, air lines, connections, clamps and seals. Make repairs, if necessary.

i02322311

Alternator - Inspect

Perkins recommends a scheduled inspection of the alternator. Inspect the alternator for loose connections and correct battery charging. Check the ammeter (if equipped) during engine operation in order to ensure correct battery performance and/or correct performance of the electrical system. Make repairs, as required.

Check the alternator and the battery charger for correct operation. If the batteries are correctly charged, the ammeter reading should be very near zero. All batteries should be kept charged. The batteries should be kept warm because temperature affects the cranking power. If the battery is too cold, the battery will not crank the engine. When the engine is not run for long periods of time or if the engine is run for short periods, the batteries may not fully charge. A battery with a low charge will freeze more easily than a battery with a full charge.

i02491869

Alternator Belt - Inspect/ Adjust/Replace (Poly V-Belt)

Inspection

To maximize the engine performance, inspect the belt (1) for wear and for cracking. Replace the belt if the belt is worn or damaged.

- If the belt (1) has more than four cracks per 25.4000 mm (1 inch) the belt must be replaced.
- Check the belt of cracks, splits, glazing, grease, and splitting.

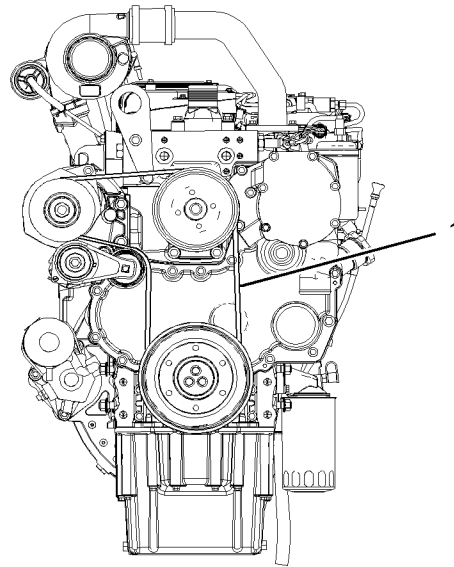

Illustration 32

g01251375

Typical example

Adjustment

This type of belt has an automatic belt tensioner.

Replace

Refer to Disassembly and Assembly manual, "Alternator Belt - Remove and Install".

i02322315

Battery - Replace

WARNING

Batteries give off combustible gases which can explode. A spark can cause the combustible gases to ignite. This can result in severe personal injury or death.

Ensure proper ventilation for batteries that are in an enclosure. Follow the proper procedures in order to help prevent electrical arcs and/or sparks near batteries. Do not smoke when batteries are serviced.

⚠ WARNING

The battery cables or the batteries should not be removed with the battery cover in place. The battery cover should be removed before any servicing is attempted.

Removing the battery cables or the batteries with the cover in place may cause a battery explosion resulting in personal injury.

1. Switch the engine to the OFF position. Remove all electrical loads.
2. Turn off any battery chargers. Disconnect any battery chargers.
3. The NEGATIVE “-” cable connects the NEGATIVE “-” battery terminal to the NEGATIVE “-” terminal on the starting motor. Disconnect the cable from the NEGATIVE “-” battery terminal.
4. The POSITIVE “+” cable connects the POSITIVE “+” battery terminal to the POSITIVE “+” terminal on the starting motor. Disconnect the cable from the POSITIVE “+” battery terminal.

Note: Always recycle a battery. Never discard a battery. Dispose of used batteries to an appropriate recycling facility.

5. Remove the used battery.
6. Install the new battery.

Note: Before the cables are connected, ensure that the engine start switch is OFF.

7. Connect the cable from the starting motor to the POSITIVE “+” battery terminal.
8. Connect the NEGATIVE “-” cable to the NEGATIVE “-” battery terminal.

i02747977

Battery Electrolyte Level - Check

When the engine is not run for long periods of time or when the engine is run for short periods, the batteries may not fully recharge. Ensure a full charge in order to help prevent the battery from freezing. If batteries are correctly charged, the ammeter reading should be very near zero, when the engine is in operation.

⚠ WARNING

All lead-acid batteries contain sulfuric acid which can burn the skin and clothing. Always wear a face shield and protective clothing when working on or near batteries.

1. Remove the filler caps. Maintain the electrolyte level to the “FULL” mark on the battery.

If the addition of water is necessary, use distilled water. If distilled water is not available use clean water that is low in minerals. Do not use artificially softened water.

2. Check the condition of the electrolyte with a suitable battery tester.
3. Install the caps.
4. Keep the batteries clean.

Clean the battery case with one of the following cleaning solutions:

- Use a solution of 0.1 kg (0.2 lb) baking soda and 1 L (1 qt) of clean water.
- Use a solution of ammonium hydroxide.

Thoroughly rinse the battery case with clean water.

i07819485

Battery or Battery Cable - Disconnect

⚠ WARNING

The battery cables or the batteries should not be removed with the battery cover in place. The battery cover should be removed before any servicing is attempted.

Removing the battery cables or the batteries with the cover in place may cause a battery explosion resulting in personal injury.

1. Turn the start switch to the OFF position. Turn the ignition switch (if equipped) to the OFF position and remove the key and all electrical loads.
2. Disconnect the negative battery terminal. Ensure that the cable cannot contact the terminal. When four 12 volt batteries are involved, two negative connection must be disconnected.
3. Remove the positive connection.

4. Clean all disconnected connection and battery terminals.
5. Use a fine grade of sandpaper to clean the terminals and the cable clamps. Clean the items until the surfaces are bright or shiny. DO NOT remove material excessively. Excessive removal of material can cause the clamps to not fit correctly. Coat the clamps and the terminals with a suitable silicone lubricant or petroleum jelly.
6. Tape the cable connections to help prevent accidental starting.
7. Proceed with necessary system repairs.
8. To connect the battery, connect the positive connection before the negative connection.

i02854855

i02870187

Belt Tensioner - Inspect

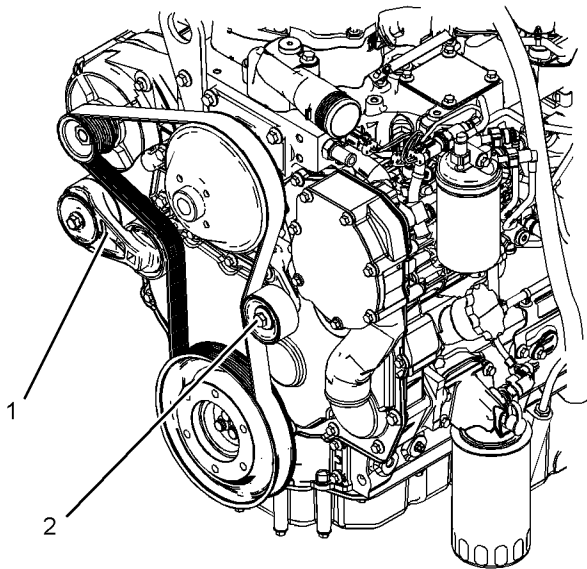

Illustration 33

g01429637

Typical example

Remove the belt. Refer to Disassembly and Assembly, "Alternator Belt - Remove and Install".

Ensure that the belt tensioner is securely installed. Visually inspect the belt tensioner (1) for damage. Check that the roller on the tensioner rotates freely. Some engines have a guide roller (2). Ensure that the guide roller is securely installed. Visually inspect the guide roller for damage. Ensure that the guide roller can rotate freely.

Install the belt. Refer to Disassembly and Assembly, "Alternator Belt - Remove and Install".

Cooling System Coolant (Commercial Heavy-Duty) - Change

NOTICE

Care must be taken to ensure that fluids are contained during performance of inspection, maintenance, testing, adjusting and repair of the product. Be prepared to collect the fluid with suitable containers before opening any compartment or disassembling any component containing fluids.

Dispose of all fluids according to Local regulations and mandates.

NOTICE

Keep all parts clean from contaminants.

Contaminants may cause rapid wear and shortened component life.

Clean the cooling system and flush the cooling system before the recommended maintenance interval if the following conditions exist:

- The engine overheats frequently.
- Foaming of the coolant is observed.
- The oil has entered the cooling system and the coolant is contaminated.
- The fuel has entered the cooling system and the coolant is contaminated.

Note: When the cooling system is cleaned, only clean water is needed.

Drain

WARNING

Pressurized System: Hot coolant can cause serious burns. To open the cooling system filler cap, stop the engine and wait until the cooling system components are cool. Loosen the cooling system pressure cap slowly in order to relieve the pressure.

1. Stop the engine and allow the engine to cool. Loosen the cooling system filler cap slowly in order to relieve any pressure. Remove the cooling system filler cap.

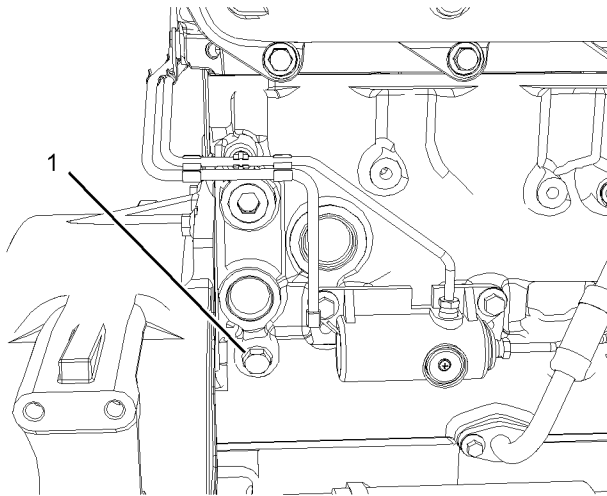

Illustration 34

g01244659

Typical example

2. Open the drain cock or remove the drain plug (1) on the engine. Open the drain cock or remove the drain plug on the radiator.

Allow the coolant to drain.

NOTICE

Dispose of used engine coolant or recycle. Various methods have been proposed to reclaim used coolant for reuse in engine cooling systems. The full distillation procedure is the only method acceptable by Perkins to reclaim the coolant.

For information regarding the disposal and the recycling of used coolant, consult your Perkins distributor.

Flush

1. Flush the cooling system with clean water in order to remove any debris.
2. Close the drain cock or install the drain plug in the engine. Close the drain cock or install the drain plug on the radiator.

NOTICE

Do not fill the cooling system faster than 5 L (1.3 US gal) per minute to avoid air locks.

Cooling system air locks may result in engine damage.

3. Fill the cooling system with clean water. Install the cooling system filler cap.

4. Start and run the engine at low idle until the temperature reaches 49 to 66 °C (120 to 150 °F).
5. Stop the engine and allow the engine to cool. Loosen the cooling system filler cap slowly in order to relieve any pressure. Remove the cooling system filler cap. Open the drain cock or remove the drain plug on the engine. Open the drain cock or remove the drain plug on the radiator. Allow the water to drain. Flush the cooling system with clean water.

Fill

1. Close the drain cock or install the drain plug on the engine. Close the drain cock or install the drain plug on the radiator.

NOTICE

Do not fill the cooling system faster than 5 L (1.3 US gal) per minute to avoid air locks.

Cooling system air locks may result in engine damage.

2. Fill the cooling system with Commercial Heavy-Duty Coolant. Add Supplemental Coolant Additive to the coolant. For the correct amount, refer to the Operation and Maintenance Manual, "Fluid Recommendations" topic (Maintenance Section) for more information on cooling system specifications. Do not install the cooling system filler cap.
3. Start and run the engine at low idle. Increase the engine rpm to high idle. Run the engine at high idle for one minute in order to purge the air from the cavities of the engine block. Decrease the engine speed to low idle. Stop the engine.
4. Check the coolant level. Maintain the coolant level within 13 mm (0.5 inch) below the bottom of the pipe for filling. Maintain the coolant level in the expansion bottle (if equipped) at the correct level.

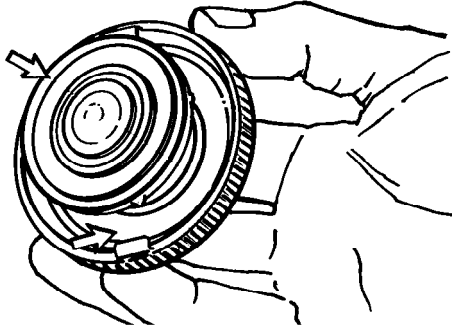

Illustration 35

g00103639

Filler cap

5. Clean the cooling system filler cap and inspect the gasket. If the gasket is damaged, discard the old filler cap and install a new filler cap. If the gasket is not damaged, use a suitable pressurizing pump in order to pressure test the filler cap. The correct pressure is stamped on the face of the filler cap. If the filler cap does not retain the correct pressure, install a new filler cap.
6. Start the engine. Inspect the cooling system for leaks and for correct operating temperature.

i02490917

Cooling System Coolant (ELC) - Change

NOTICE

Care must be taken to ensure that fluids are contained during performance of inspection, maintenance, testing, adjusting and repair of the product. Be prepared to collect the fluid with suitable containers before opening any compartment or disassembling any component containing fluids.

Dispose of all fluids according to Local regulations and mandates.

NOTICE

Keep all parts clean from contaminants.

Contaminants may cause rapid wear and shortened component life.

Clean the cooling system and flush the cooling system before the recommended maintenance interval if the following conditions exist:

- The engine overheats frequently.

- Foaming of the coolant is observed.
- The oil has entered the cooling system and the coolant is contaminated.
- The fuel has entered the cooling system and the coolant is contaminated.

Note: When the cooling system is cleaned, only clean water is needed when the ELC is drained and replaced.

Note: Inspect the water pump and the water temperature regulator after the cooling system has been drained. This is a good opportunity to replace the water pump, the water temperature regulator and the hoses, if necessary.

Drain

WARNING

Pressurized System: Hot coolant can cause serious burns. To open the cooling system filler cap, stop the engine and wait until the cooling system components are cool. Loosen the cooling system pressure cap slowly in order to relieve the pressure.

1. Stop the engine and allow the engine to cool. Loosen the cooling system filler cap slowly in order to relieve any pressure. Remove the cooling system filler cap.

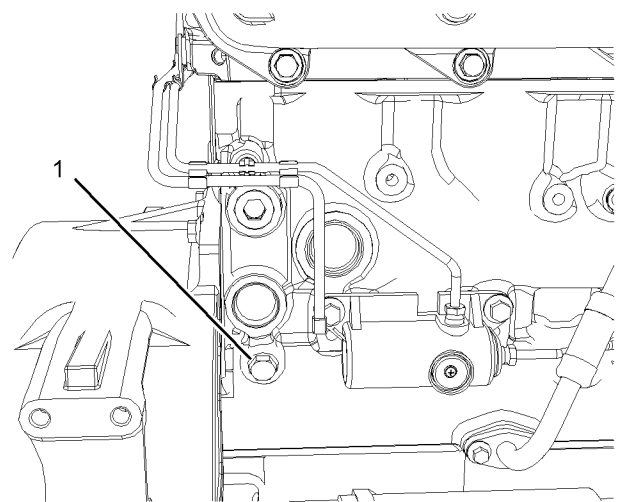

Illustration 36

g01244659

Typical example

2. Open the drain cock or remove the drain plug (1) on the engine. Open the drain cock or remove the drain plug on the radiator.

Allow the coolant to drain.

NOTICE

Dispose of used engine coolant or recycle. Various methods have been proposed to reclaim used coolant for reuse in engine cooling systems. The full distillation procedure is the only method acceptable by Perkins to reclaim the coolant.

For information regarding the disposal and the recycling of used coolant, consult your Perkins dealer or your Perkins distributor.

Flush

1. Flush the cooling system with clean water in order to remove any debris.
2. Close the drain cock or install the drain plug in the engine. Close the drain cock or install the drain plug on the radiator.

NOTICE

Do not fill the cooling system faster than 5 L (1.3 US gal) per minute to avoid air locks.

Cooling system air locks may result in engine damage.

3. Fill the cooling system with clean water. Install the cooling system filler cap.
4. Start and run the engine at low idle until the temperature reaches 49 to 66 °C (120 to 150 °F).
5. Stop the engine and allow the engine to cool. Loosen the cooling system filler cap slowly in order to relieve any pressure. Remove the cooling system filler cap. Open the drain cock or remove the drain plug on the engine. Open the drain cock or remove the drain plug on the radiator. Allow the water to drain. Flush the cooling system with clean water.

Fill

1. Close the drain cock or install the drain plug on the engine. Close the drain cock or install the drain plug on the radiator.

NOTICE

Do not fill the cooling system faster than 5 L (1.3 US gal) per minute to avoid air locks.

Cooling system air locks may result in engine damage.

2. Fill the cooling system with Extended Life Coolant (ELC). Refer to the Operation and Maintenance Manual, "Fluid Recommendations" topic (Maintenance Section) for more information on cooling system specifications. Do not install the cooling system filler cap.
 3. Start and run the engine at low idle. Increase the engine rpm to high idle. Run the engine at high idle for one minute in order to purge the air from the cavities of the engine block. Decrease the engine speed to low idle. Stop the engine.
 4. Check the coolant level. Maintain the coolant level within 13 mm (0.5 inch) below the bottom of the pipe for filling. Maintain the coolant level in the expansion bottle (if equipped) at the correct level.
-

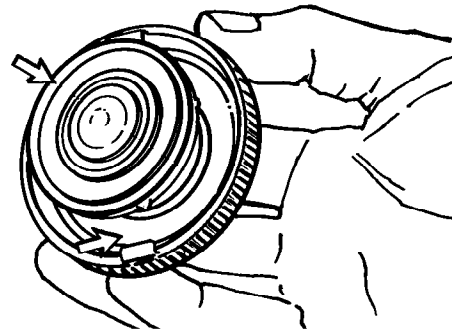

Illustration 37

g00103639

Filler cap

5. Clean the cooling system filler cap and inspect the gasket. If the gasket is damaged, discard the old filler cap and install a new filler cap. If the gasket is not damaged, use a suitable pressurizing pump in order to pressure test the filler cap. The correct pressure is stamped on the face of the filler cap. If the filler cap does not retain the correct pressure, install a new filler cap.

- Start the engine. Inspect the cooling system for leaks and for correct operating temperature.

i04408743

Cooling System Coolant Level - Check

Engines With a Coolant Recovery Tank

Note: The cooling system may not have been provided by Perkins. The procedure that follows is for typical cooling systems. Refer to the OEM information for the correct procedures.

Check the coolant level when the engine is stopped and cool.

NOTICE

When any servicing or repair of the engine cooling system is performed, the procedure must be performed with the engine on level ground. This will allow you to accurately check the coolant level. This will also help in avoiding the risk of introducing an air lock into the coolant system.

- Observe the coolant level in the coolant recovery tank. Maintain the coolant level to "COLD FULL" mark on the coolant recovery tank.

WARNING

Pressurized System: Hot coolant can cause serious burns. To open the cooling system filler cap, stop the engine and wait until the cooling system components are cool. Loosen the cooling system pressure cap slowly in order to relieve the pressure.

- Loosen filler cap slowly in order to relieve any pressure. Remove the filler cap.
- Pour the correct coolant mixture into the tank. Refer to the Operation and Maintenance Manual, "Refill Capacities and Recommendations" for information on the correct mixture and type of coolant. Refer to the Operation and Maintenance Manual, "Refill Capacities and Recommendations" for the cooling system capacity. Do not fill the coolant recovery tank above "COLD FULL" mark.

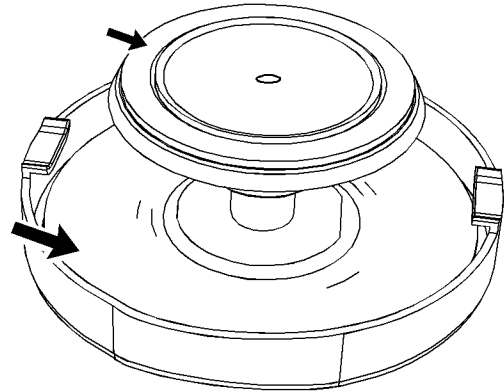

Illustration 38

g02590196

Filler cap

- Clean filler cap and the receptacle. Reinstall the filler cap and inspect the cooling system for leaks.

Note: The coolant will expand as the coolant heats up during normal engine operation. The additional volume will be forced into the coolant recovery tank during engine operation. When the engine is stopped and cool, the coolant will return to the engine.

Engines Without a Coolant Recovery Tank

Check the coolant level when the engine is stopped and cool.

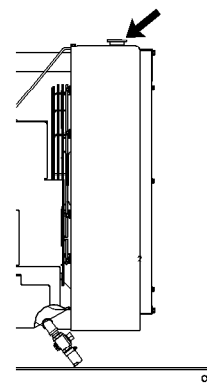

Illustration 39

g00285520

Cooling system filler cap

 **WARNING**

Pressurized System: Hot coolant can cause serious burns. To open the cooling system filler cap, stop the engine and wait until the cooling system components are cool. Loosen the cooling system pressure cap slowly in order to relieve the pressure.

1. Remove the cooling system filler cap slowly in order to relieve pressure.
2. Maintain the coolant level at the maximum mark that is correct for your application. If the engine is equipped with a sight glass, maintain the coolant level to the correct level in the sight glass.
3. Clean the cooling system filler cap and inspect the gasket. If the gasket is damaged, discard the old filler cap and install a new filler cap. If the gasket is not damaged, use a suitable pressurizing pump in order to pressure test the filler cap. The correct pressure is stamped on the face of the filler cap. If the filler cap does not retain the correct pressure, install a new filler cap.
4. Inspect the cooling system for leaks.

i03644948

Cooling System Supplemental Coolant Additive (SCA) - Test/Add

 **WARNING**

Cooling system coolant additive contains alkali. To help prevent personal injury, avoid contact with the skin and the eyes. Do not drink cooling system coolant additive.

Test for SCA Concentration

Heavy-Duty Coolant/Antifreeze and SCA

NOTICE

Do not exceed the recommended six percent supplemental coolant additive concentration.

Use a Coolant Conditioner Test Kit in order to check the concentration of the SCA.

Add the SCA, If Necessary

NOTICE

Do not exceed the recommended amount of supplemental coolant additive concentration. Excessive supplemental coolant additive concentration can form deposits on the higher temperature surfaces of the cooling system, reducing the engine's heat transfer characteristics. Reduced heat transfer could cause cracking of the cylinder head and other high temperature components. Excessive supplemental coolant additive concentration could also result in radiator tube blockage, overheating, and/or accelerated water pump seal wear. Never use both liquid supplemental coolant additive and the spin-on element (if equipped) at the same time. The use of those additives together could result in supplemental coolant additive concentration exceeding the recommended maximum.

 **WARNING**

Pressurized System: Hot coolant can cause serious burns. To open the cooling system filler cap, stop the engine and wait until the cooling system components are cool. Loosen the cooling system pressure cap slowly in order to relieve the pressure.

NOTICE

When any servicing or repair of the engine cooling system is performed the procedure must be performed with the engine on level ground. This will allow you to accurately check the coolant level. This will also help in avoiding the risk of introducing an air lock into the coolant system.

1. Slowly loosen the cooling system filler cap in order to relieve the pressure. Remove the cooling system filler cap.

Note: Always discard drained fluids according to local regulations.

2. If necessary, drain some coolant from the cooling system into a suitable container in order to allow space for the extra SCA.
3. Add the correct amount of SCA. Refer to the Operation and Maintenance Manual, "Refill Capacities and Recommendations" for more information on SCA requirements.

Maintenance Section
Crankcase Breather (Canister) - Replace

4. Clean the cooling system filler cap and inspect the gasket. If the gasket is damaged, discard the old filler cap and install a new filler cap. If the gasket is not damaged, use a suitable pressurizing pump in order to pressure test the filler cap. The correct pressure is stamped on the face of the filler cap. If the filler cap does not retain the correct pressure, install a new filler cap.

i02866782

Crankcase Breather (Canister) - Replace

NOTICE

Ensure that the engine is stopped before any servicing or repair is performed.

Note: The breather assembly is not installed on all engines.

1. Place a container under the canister (1).
2. Clean the outside of the canister. Use a suitable tool in order to remove the canister.

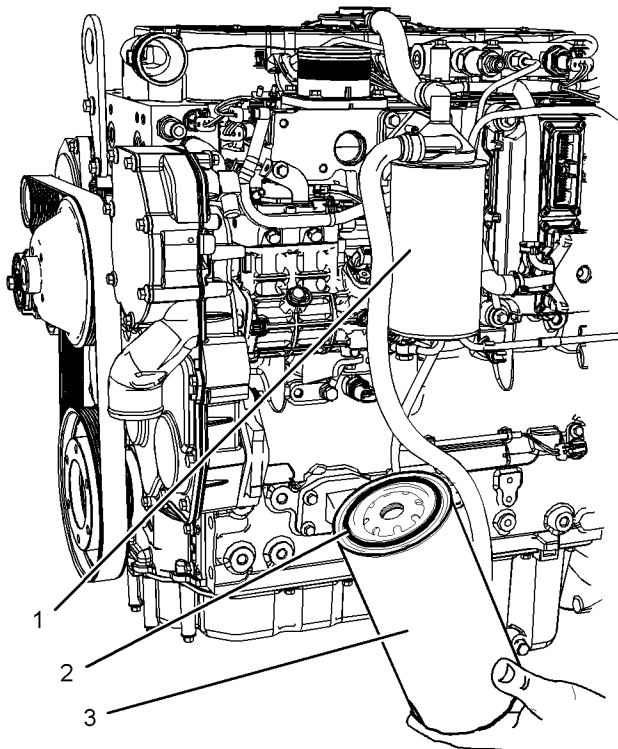

Illustration 40

g01428096

Typical example

3. Lubricate the O ring seal (2) on the new canister (3) with clean engine lubricating oil. Install the new canister. Tighten the canister to 12 N·m (8 lb ft). Do not overtighten the canister.
4. Remove the container. Dispose of the old canister and any split oil in a safe place.

i02151646

Driven Equipment - Check

Refer to the OEM specifications for more information on the following maintenance recommendations for the driven equipment:

- Inspection
- Adjustment
- Lubrication
- Other maintenance recommendations

Perform any maintenance for the driven equipment which is recommended by the OEM.

i01909392

Engine - Clean

⚠ WARNING

Personal injury or death can result from high voltage.

Moisture can create paths of electrical conductivity.

Make sure that the electrical system is OFF. Lock out the starting controls and tag the controls "DO NOT OPERATE".

NOTICE

Accumulated grease and oil on an engine is a fire hazard. Keep the engine clean. Remove debris and fluid spills whenever a significant quantity accumulates on the engine.

NOTICE

Failure to protect some engine components from washing may make your engine warranty invalid. Allow the engine to cool for one hour before washing the engine.

Periodic cleaning of the engine is recommended. Steam cleaning the engine will remove accumulated oil and grease. A clean engine provides the following benefits:

- Easy detection of fluid leaks
- Maximum heat transfer characteristics
- Ease of maintenance

Note: Caution must be used in order to prevent electrical components from being damaged by excessive water when the engine is cleaned. Pressure washers and steam cleaners should not be directed at any electrical connectors or the junction of cables into the rear of the connectors. Avoid electrical components such as the alternator, the starter, and the ECM. Protect the fuel injection pump from fluids in order to wash the engine.

i02334355

Engine Air Cleaner Element (Dual Element) - Clean/Replace

NOTICE

Never run the engine without an air cleaner element installed. Never run the engine with a damaged air cleaner element. Do not use air cleaner elements with damaged pleats, gaskets or seals. Dirt entering the engine causes premature wear and damage to engine components. Air cleaner elements help to prevent airborne debris from entering the air inlet.

NOTICE

Never service the air cleaner element with the engine running since this will allow dirt to enter the engine.

Servicing the Air Cleaner Elements

Note: The air filter system may not have been provided by Perkins. The procedure that follows is for a typical air filter system. Refer to the OEM information for the correct procedure.

If the air cleaner element becomes plugged, the air can split the material of the air cleaner element. Unfiltered air will drastically accelerate internal engine wear. Refer to the OEM information for the correct air cleaner elements for your application.

- Check the precleaner (if equipped) and the dust bowl daily for accumulation of dirt and debris. Remove any dirt and debris, as needed.
- Operating in dirty conditions may require more frequent service of the air cleaner element.

- The air cleaner element should be replaced at least one time per year. This replacement should be performed regardless of the number of cleanings.

Replace the dirty air cleaner elements with clean air cleaner elements. Before installation, the air cleaner elements should be thoroughly checked for tears and/or holes in the filter material. Inspect the gasket or the seal of the air cleaner element for damage. Maintain a supply of suitable air cleaner elements for replacement purposes.

Dual Element Air Cleaners

The dual element air cleaner contains a primary air cleaner element and a secondary air cleaner element.

The primary air cleaner element can be used up to six times if the element is properly cleaned and properly inspected. The primary air cleaner element should be replaced at least one time per year. This replacement should be performed regardless of the number of cleanings.

The secondary air cleaner element is not serviceable. Refer to the OEM information for instructions in order to replace the secondary air cleaner element.

When the engine is operating in environments that are dusty or dirty, air cleaner elements may require more frequent replacement.

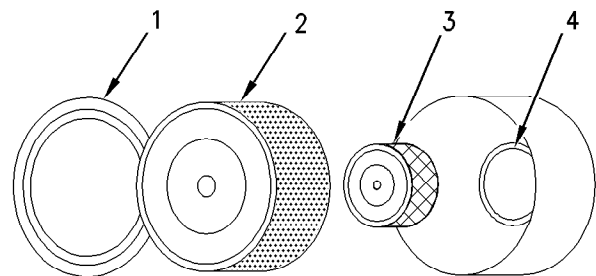

Illustration 41

g00736431

- (1) Cover
- (2) Primary air cleaner element
- (3) Secondary air cleaner element
- (4) Air inlet

1. Remove the cover. Remove the primary air cleaner element.
2. The secondary air cleaner element should be removed and discarded for every three cleanings of the primary air cleaner element.

Note: Refer to "Cleaning the Primary Air Cleaner Elements".

3. Cover the air inlet with tape in order to keep dirt out.
4. Clean the inside of the air cleaner cover and body with a clean, dry cloth.
5. Remove the tape from the air inlet. Install the secondary air cleaner element. Install a primary air cleaner element that is new or cleaned.
6. Install the air cleaner cover.
7. Reset the air cleaner service indicator.

Cleaning the Primary Air Cleaner Elements

Refer to the OEM information in order to determine the number of times that the primary filter element can be cleaned. When the primary air cleaner element is cleaned, check for rips or tears in the filter material. The primary air cleaner element should be replaced at least one time per year. This replacement should be performed regardless of the number of cleanings.

NOTICE

Do not tap or strike the air cleaner element.

Do not wash the primary air cleaner element.

Use low pressure (207 kPa; 30 psi maximum) pressurized air or vacuum cleaning to clean the primary air cleaner element.

Take extreme care in order to avoid damage to the air cleaner elements.

Do not use air cleaner elements that have damaged pleats, gaskets or seals.

Refer to the OEM information in order to determine the number of times that the primary air cleaner element can be cleaned. Do not clean the primary air filter element more than three times. The primary air cleaner element must be replaced at least one time per year.

Cleaning the air filter element will not extend the life of the air filter element.

Visually inspect the primary air cleaner element before cleaning. Inspect air cleaner elements for damage to the pleats, the seals, the gaskets and the outer cover. Discard any damaged air cleaner element.

Two methods may be used in order to clean the primary air cleaner element:

- pressurized air
- Vacuum cleaning

Pressurized Air

WARNING

Personal injury can result from air pressure.

Personal injury can result without following proper procedure. When using pressure air, wear a protective face shield and protective clothing.

Maximum air pressure at the nozzle must be less than 205 kPa (30 psi) for cleaning purposes.

Pressurized air can be used to clean primary air cleaner elements that have not been cleaned more than three times. Use filtered, dry air with a maximum pressure of 207 kPa (30 psi). Pressurized air will not remove deposits of carbon and oil.

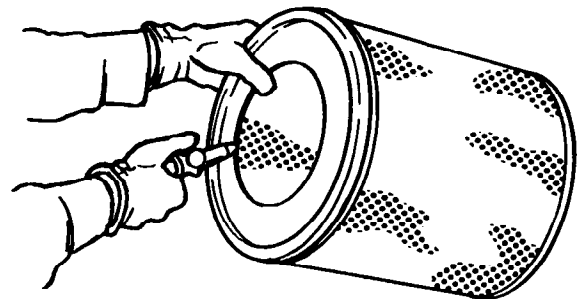

Illustration 42

g00281692

Note: When the primary air cleaner elements are cleaned, always begin with the clean side (inside) in order to force dirt particles toward the dirty side (outside).

Aim the air hose so that air flows along the length of the filter. Follow the direction of the paper pleats in order to prevent damage to the pleats. Do not aim the air directly at the face of the paper pleats.

Note: Refer to “Inspecting the Primary Air Cleaner Elements”.

Vacuum Cleaning

Vacuum cleaning is a good method for removing accumulated dirt from the dirty side (outside) of a primary air cleaner element. Vacuum cleaning is especially useful for cleaning primary air cleaner elements which require daily cleaning because of a dry, dusty environment.

Cleaning from the clean side (inside) with pressurized air is recommended prior to vacuum cleaning the dirty side (outside) of a primary air cleaner element.

Note: Refer to “Inspecting the Primary Air Cleaner Elements”.

Inspecting the Primary Air Cleaner Elements

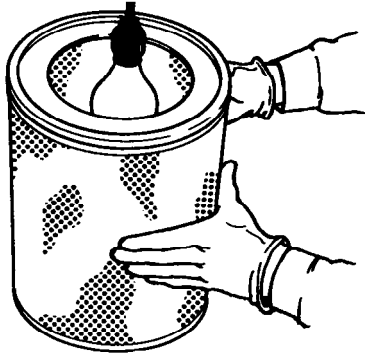

Illustration 43

g00281693

Inspect the clean, dry primary air cleaner element. Use a 60 watt blue light in a dark room or in a similar facility. Place the blue light in the primary air cleaner element. Rotate the primary air cleaner element. Inspect the primary air cleaner element for tears and/or holes. Inspect the primary air cleaner element for light that may show through the filter material. If it is necessary in order to confirm the result, compare the primary air cleaner element to a new primary air cleaner element that has the same part number.

Do not use a primary air cleaner element that has any tears and/or holes in the filter material. Do not use a primary air cleaner element with damaged pleats, gaskets or seals. Discard damaged primary air cleaner elements.

i02335405

Engine Air Cleaner Service Indicator - Inspect

Some engines may be equipped with a different service indicator.

Some engines are equipped with a differential gauge for inlet air pressure. The differential gauge for inlet air pressure displays the difference in the pressure that is measured before the air cleaner element and the pressure that is measured after the air cleaner element. As the air cleaner element becomes dirty, the pressure differential rises. If your engine is equipped with a different type of service indicator, follow the OEM recommendations in order to service the air cleaner service indicator.

The service indicator may be mounted on the air cleaner element or in a remote location.

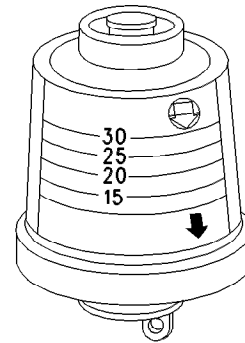

Illustration 44

g00103777

Typical service indicator

Observe the service indicator. The air cleaner element should be cleaned or the air cleaner element should be replaced when one of the following conditions occur:

- The yellow diaphragm enters the red zone.
- The red piston locks in the visible position.

Test the Service Indicator

Service indicators are important instruments.

- Check for ease of resetting. The service indicator should reset in less than three pushes.
- Check the movement of the yellow core when the engine is accelerated to the engine rated speed. The yellow core should latch at the greatest vacuum that is attained.

If the service indicator does not reset easily, or if the yellow core does not latch at the greatest vacuum, the service indicator should be replaced. If the new service indicator will not reset, the hole for the service indicator may be restricted.

The service indicator may need to be replaced frequently in environments that are severely dusty.

i05967804

Engine Air Precleaner - Check/Clean (If Equipped)

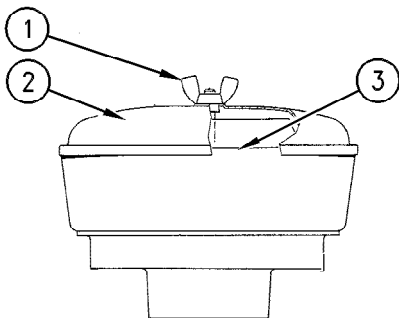

Illustration 45

g00287039

Typical example

- (1) Wing nut
- (2) Cover
- (3) Body

Remove wing nut (1) and cover (2). Check for an accumulation of dirt and debris in body (3). Clean the body, if necessary.

After cleaning the pre-cleaner, install cover (2) and wing nut (1).

Note: When the engine is operated in dusty applications, more frequent cleaning is required.

i07819538

Engine Mounts - Inspect

Note: The engine mounts may not have been supplied by Perkins. Refer to the Original Equipment Manufacturer (OEM) information for further details on the engine mounts and the correct bolt torque.

Inspect the engine mounts for deterioration and for correct bolt torque. Excessive engine vibration can be caused by the following conditions:

- Incorrect mounting of the engine
- Deterioration of the engine mounts
- Loose engine mounts

Any engine mount that shows deterioration should be replaced. Refer to the OEM information for the recommended torques.

When the engine mounts are supplied by Perkins the maintenance procedure will be supplied in the Disassembly and Assembly manual for your engine.

i05909059

Engine Oil Level - Check

WARNING

Hot oil and hot components can cause personal injury. Do not allow hot oil or hot components to contact the skin.

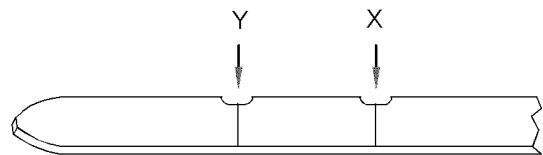

Illustration 46

g01165836

(Y) "Min" mark. (X) "Max" mark.



Illustration 47

g02173847

(L) "Min" mark. (H) "Max" mark.

NOTICE

Perform this maintenance with the engine stopped.

Note: Ensure that the engine is either level or that the engine is in the normal operating position in order to obtain a true level indication.

Note: After the engine has been switched OFF, wait for 10 minutes in order to allow the engine oil to drain to the oil pan. Then, check the oil level.

1. Maintain the oil level between the "ADD" mark (Y) and the "FULL" mark (X) on the engine oil dipstick. Or maintain the engine oil level between the H and L mark. Do not over fill the crankcase.

NOTICE

Operating your engine when the oil level is above the "FULL" mark could cause your crankshaft to dip into the oil. The air bubbles created from the crankshaft dipping into the oil reduces the oil's lubricating characteristics and could result in the loss of power.

2. Remove the oil filler cap and add oil, if necessary. Clean the oil filler cap. Install the oil filler cap.

i01907674

Engine Oil Sample - Obtain

The condition of the engine lubricating oil may be checked at regular intervals as part of a preventive maintenance program. Perkins include an oil sampling valve as an option. The oil sampling valve (if equipped) is included in order to regularly sample the engine lubricating oil. The oil sampling valve is positioned on the oil filter head or the oil sampling valve is positioned on the cylinder block.

Perkins recommends using a sampling valve in order to obtain oil samples. The quality and the consistency of the samples are better when a sampling valve is used. The location of the sampling valve allows oil that is flowing under pressure to be obtained during normal engine operation.

Obtain the Sample and the Analysis

WARNING

Hot oil and hot components can cause personal injury. Do not allow hot oil or hot components to contact the skin.

In order to help obtain the most accurate analysis, record the following information before an oil sample is taken:

- The date of the sample

- Engine model
- Engine number
- Service hours on the engine
- The number of hours that have accumulated since the last oil change
- The amount of oil that has been added since the last oil change

Ensure that the container for the sample is clean and dry. Also ensure that the container for the sample is clearly labelled.

To ensure that the sample is representative of the oil in the crankcase, obtain a warm, well mixed oil sample.

To avoid contamination of the oil samples, the tools and the supplies that are used for obtaining oil samples must be clean.

The sample can be checked for the following: the quality of the oil, the existence of any coolant in the oil, the existence of any ferrous metal particles in the oil and the existence of any nonferrous metal particles in the oil.

i02867741

Engine Oil and Filter - Change

WARNING

Hot oil and hot components can cause personal injury. Do not allow hot oil or hot components to contact the skin.

NOTICE

Care must be taken to ensure that fluids are contained during performance of inspection, maintenance, testing, adjusting and repair of the product. Be prepared to collect the fluid with suitable containers before opening any compartment or disassembling any component containing fluids.

Dispose of all fluids according to local regulations and mandates.

NOTICE

Keep all parts clean from contaminants.

Contaminants may cause rapid wear and shortened component life.

Maintenance Section
Engine Oil and Filter - Change

Do not drain the engine lubricating oil when the engine is cold. As the engine lubricating oil cools, suspended waste particles settle on the bottom of the oil pan. The waste particles are not removed with draining cold oil. Drain the oil pan with the engine stopped. Drain the oil pan with the oil warm. This draining method allows the waste particles that are suspended in the oil to be drained properly.

Failure to follow this recommended procedure will cause the waste particles to be recirculated through the engine lubrication system with the new oil.

Drain the Engine Lubricating Oil

Note: Ensure that the vessel that will be used is large enough to collect the waste oil.

After the engine has been run at the normal operating temperature, stop the engine. Use one of the following methods to drain the engine oil pan:

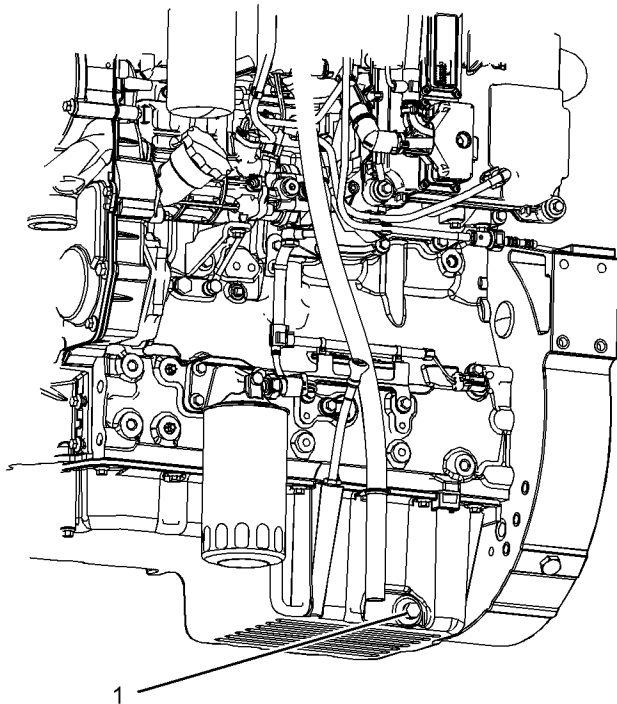

Illustration 48

g01428532

Typical example

- If the engine is equipped with a drain valve, turn the drain valve knob counterclockwise in order to drain the oil. After the oil has drained, turn the drain valve knob clockwise in order to close the drain valve.

- If the engine is not equipped with a drain valve, remove the oil drain plug (1) in order to allow the oil to drain. If the engine is equipped with a shallow oil pan, remove the bottom oil drain plugs from both ends of the oil pan.

After the oil has drained, the oil drain plugs should be cleaned and installed. If necessary, replace the O ring seal. Tighten the drain plug to 34 N·m (25 lb ft).

Replace the Oil Filter

NOTICE

Perkins oil filters are manufactured to Perkins specifications. Use of an oil filter that is not recommended by Perkins could result in severe damage to the engine bearings, crankshaft, etc., as a result of the larger waste particles from unfiltered oil entering the engine lubricating system. Only use oil filters recommended by Perkins.

1. Remove the oil filter with a suitable tool. A horizontally installed oil filter can be drained before removal.

Note: The following actions can be carried out as part of the preventive maintenance program.

2. Cut the oil filter open with a suitable tool. Break apart the pleats and inspect the oil filter for metal debris. An excessive amount of metal debris in the oil filter may indicate early wear or a pending failure.

Use a magnet to differentiate between the ferrous metals and the nonferrous metals that are found in the oil filter element. Ferrous metals may indicate wear on the steel and cast iron parts of the engine.

Nonferrous metals may indicate wear on the aluminum parts, brass parts or bronze parts of the engine. Parts that may be affected include the following items: main bearings, rod bearings and turbocharger bearings.

Due to normal wear and friction, it is not uncommon to find small amounts of debris in the oil filter.

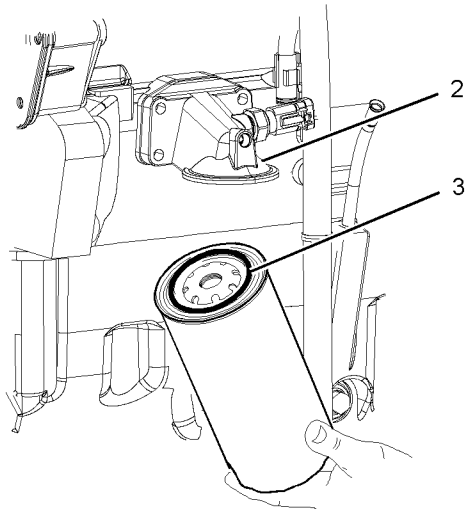

Illustration 49

g01187802

Typical example

3. Clean the sealing surface of the oil filter head (2). Ensure that the union is secure in the filter head.
4. Apply clean engine oil to the O ring seal (3) for the new oil filter.

NOTICE

Do not fill the oil filters with oil before installing them. This oil would not be filtered and could be contaminated. Contaminated oil can cause accelerated wear to engine components.

5. Install the oil filter. Tighten the oil filter to 12 N·m (8.8 lb ft). Do not overtighten the oil filter.

Horizontal Oil Filter

Illustration 50

g01428535

Typical example

Note: Some oil filters may be installed horizontally. Refer to illustration 50. This type of oil filter assembly can be drained before the filter is removed. Start at step 1 in order to remove the oil filter and install the oil filter.

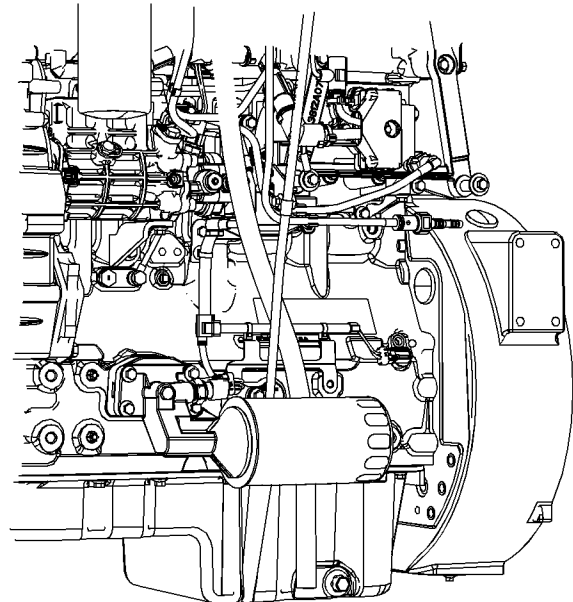
Fill the Oil Pan

1. Remove the oil filler cap. Refer to this Operation and Maintenance Manual, "Fluid Recommendations" for more information on suitable oils. Fill the oil pan with the correct amount of new engine lubricating oil. Refer to this Operation and Maintenance Manual, "Refill Capacities" for more information on refill capacities.

NOTICE

If equipped with an auxiliary oil filter system or a remote filter system, follow the OEM or the filter manufacturer's recommendations. Under filling or over filling the crankcase with oil can cause engine damage.

Maintenance Section
Engine Oil and Filter - Change

2. Start the engine and run the engine at "LOW IDLE" for two minutes. Perform this procedure in order to ensure that the lubrication system has oil and that the oil filters are filled. Inspect the oil filter for oil leaks.
3. Stop the engine and allow the oil to drain back to the oil pan for a minimum of ten minutes.

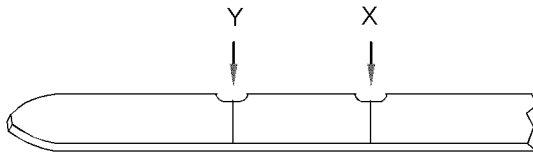

Illustration 51

g01165836

(Y) "Min" mark. (X) "Max" mark.

4. Remove the engine oil level gauge in order to check the oil level. Maintain the oil level between the "MIN" and "MAX" marks on the engine oil level gauge.

i02869394

Engine Oil and Filter - Change (CG-4 Oil)

CG-4 engine oil may be used. If this grade of engine oil is used a 250 hour service interval is required for the engine oil and the engine oil filter.

i02503009

Engine Valve Lash - Inspect/ Adjust

This maintenance is recommended by Perkins as part of a lubrication and preventive maintenance schedule in order to help provide maximum engine life.

NOTICE

Only qualified service personnel should perform this maintenance. Refer to the Service Manual or your authorized Perkins dealer or your Perkins distributor for the complete valve lash adjustment procedure.

Operation of Perkins engines with incorrect valve lash can reduce engine efficiency, and also reduce engine component life.

WARNING

Ensure that the engine can not be started while this maintenance is being performed. To help prevent possible injury, do not use the starting motor to turn the flywheel.

Hot engine components can cause burns. Allow additional time for the engine to cool before measuring/adjusting valve lash clearance.

Ensure that the engine is stopped before measuring the valve lash. The engine valve lash can be inspected and adjusted when the temperature of the engine is hot or cold.

Refer to Systems Operation/Testing and Adjusting, "Engine Valve Lash - Inspect/Adjust" for more information.

i02862580

i02683336

Exhaust Manifold - Inspect

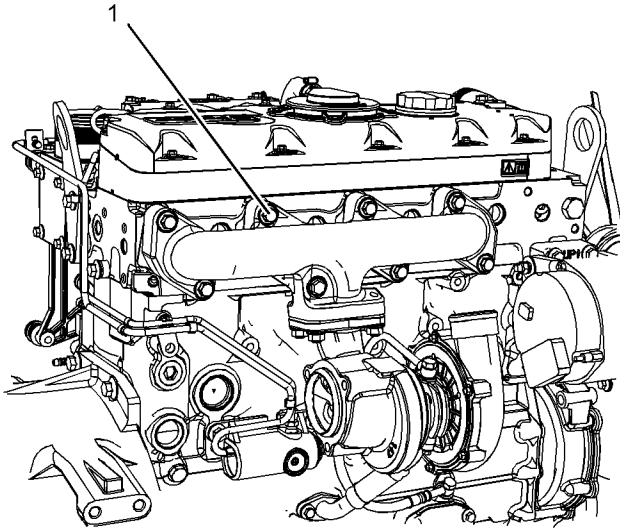

Illustration 52

g01425829

1. Inspect the exhaust manifold for damage. If necessary, replace the exhaust manifold. Refer to Disassembly and Assembly, "Exhaust Manifold - Remove and Install".
2. Check the torque on all the bolts (1). The bolts must be tightened in the sequence that is shown in illustration 53 .

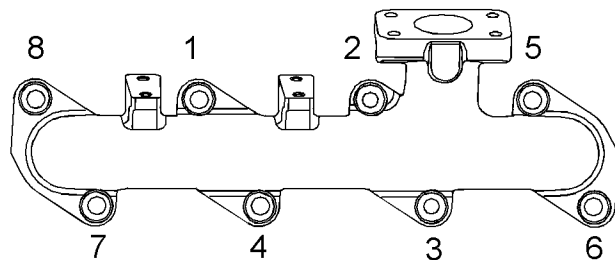

Illustration 53

g01363916

3. Tighten the bolts to the following torque 40 N·m (29.5 lb ft).

Fan Clearance - Check

There are different types of cooling systems. Refer to the OEM for information on clearance for the fan.

Ensure that the engine is stopped. Ensure that the cooling system is full. The clearance between the cover (1) and the fan (2) will require checking. The gap (A) between the edge of the cover and the tip of the fan blade must be checked in four equally spaced positions.

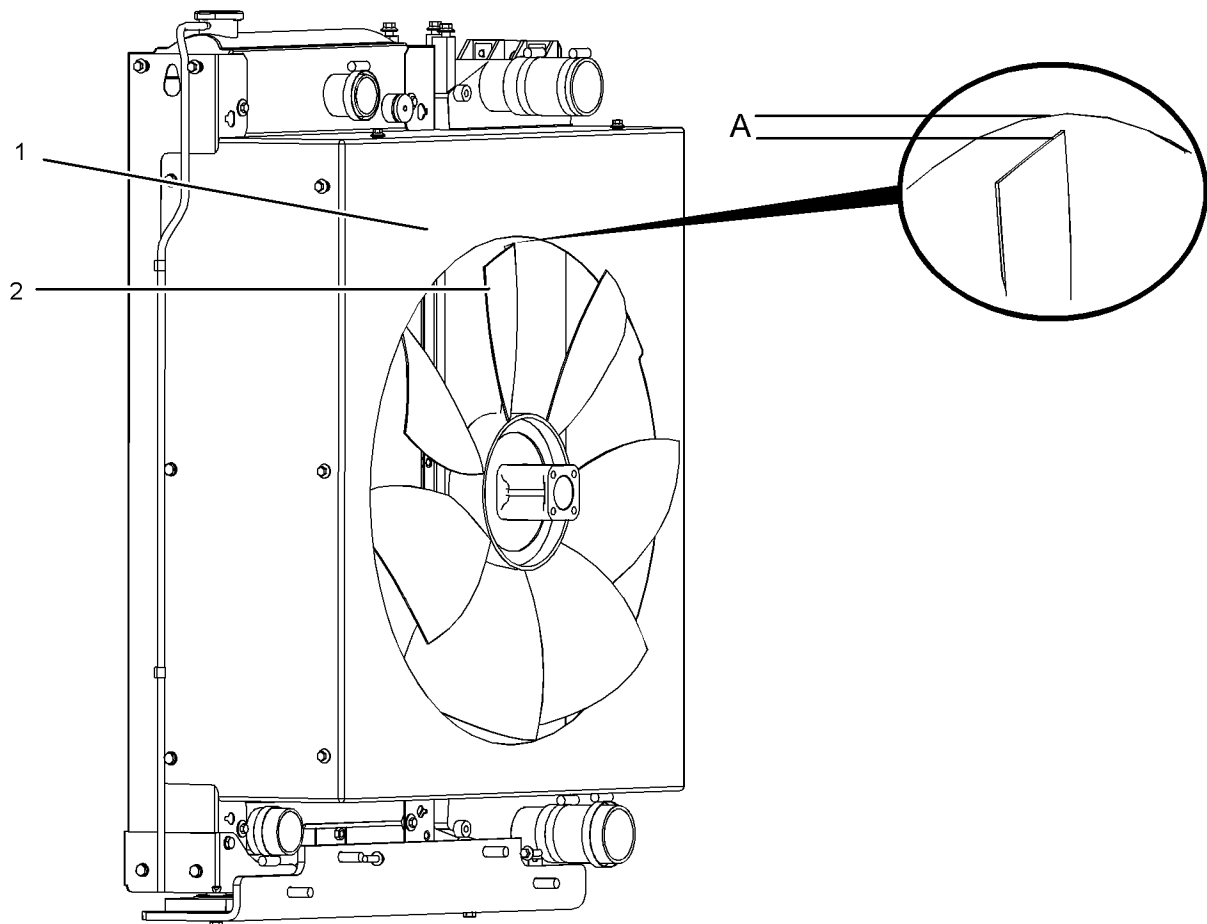

Illustration 54

g01348394

Adjustment of the cover will change the clearance (gap) between the edge of the cover and the tip of the fan blade. Ensure that the cover is centralized to the fan.

The maximum clearance is 12.5 mm (0.4921 inch).
The minimum clearance is 6 mm (0.2362 inch).

i02871014

Fuel System - Prime

WARNING

Contact with high pressure fuel may cause fluid penetration and burn hazards. High pressure fuel spray may cause a fire hazard. Failure to follow these inspection, maintenance and service instructions may cause personal injury or death.

Refer to the Operation and Maintenance Manual, "General Hazard Information and High Pressure Fuel Lines" before adjustments and repairs are performed.

Note: Refer to Systems Operation, Testing and Adjusting, "Cleanliness of Fuel System Components" for detailed information on the standards of cleanliness that must be observed during ALL work on the fuel system.

Ensure that all adjustments and repairs are performed by authorized personnel that have had the correct training.

NOTICE

Do not crank the engine continuously for more than 30 seconds. Allow the starting motor to cool for two minutes before cranking the engine again.

If air enters the fuel system, the air must be purged from the fuel system before the engine can be started. Air can enter the fuel system when the following events occur:

- The fuel tank is empty or the fuel tank has been partially drained.
- The low pressure fuel lines are disconnected.

- A leak exists in the low pressure fuel system.
- The fuel filter has been replaced.

Hand Fuel Priming Pump

Use the following procedures in order to remove air from the fuel system:

1. Ensure that the fuel system is in working order.
Check that the fuel supply valve (if equipped) is in the "ON" position.

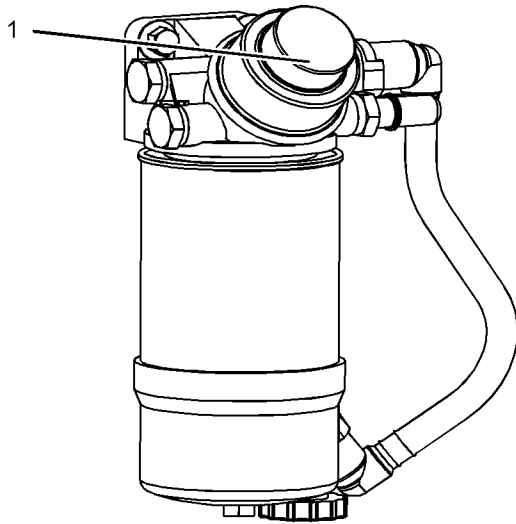

Illustration 55

g01476592

Typical example

2. Operate the fuel priming pump (1). Count the number of operations of the fuel priming pump. After 100 depressions of the fuel priming pump stop.
3. The engine fuel system should now be primed and the engine should now be able to start.
4. Operate the engine starter and crank the engine. After the engine has started, operate the engine at low idle for a minimum of five minutes, immediately after air has been removed from the fuel system.

Note: Operating the engine for this period of time will help ensure that the fuel system is free of air.

Note: Do not loosen the high pressure fuel line in order to purge air from the fuel system. This procedure is not required.

WARNING

Contact with high pressure fuel may cause fluid penetration and burn hazards. High pressure fuel spray may cause a fire hazard. Failure to follow these inspection, maintenance and service instructions may cause personal injury or death.

After the engine has stopped, you must wait for 60 seconds in order to allow the fuel pressure to be purged from the high pressure fuel lines before any service or repair is performed on the engine fuel lines. If necessary, perform minor adjustments. Repair any leaks from the low pressure fuel system and from the cooling, lubrication or air systems. Replace any high pressure fuel line that has leaked. Refer to Disassembly and Assembly Manual, "Fuel Injection Lines - Install".

If you inspect the engine in operation, always use the proper inspection procedure in order to avoid a fluid penetration hazard. Refer to Operation and Maintenance Manual, "General hazard Information".

i02869425

Fuel System Primary Filter (Water Separator) Element - Replace

Type One Filter

WARNING

Fuel leaked or spilled onto hot surfaces or electrical components can cause a fire. To help prevent possible injury, turn the start switch off when changing fuel filters or water separator elements. Clean up fuel spills immediately.

Note: Refer to Testing and Adjusting Manual , "Cleanliness of Fuel System Components" for detailed information on the standards of cleanliness that must be observed during ALL work on the fuel system.

NOTICE

Ensure that the engine is stopped before any servicing or repair is performed.

Maintenance Section
Fuel System Primary Filter (Water Separator) Element - Replace

After the engine has stopped, you must wait for 60 seconds in order to allow the fuel pressure to be purged from the high pressure fuel lines before any service or repair is performed on the engine fuel lines. If necessary, perform minor adjustments. Repair any leaks from the low pressure fuel system and from the cooling, lubrication or air systems. Replace any high pressure fuel line that has leaked. Refer to Disassembly and assembly Manual, "Fuel Injection Lines - Install".

1. Turn the fuel supply valve (if equipped) to the OFF position before performing this maintenance.
2. Place a suitable container under the water separator in order to catch any fuel that might spill. Clean up any spilled fuel. Clean the outside of the water separator.

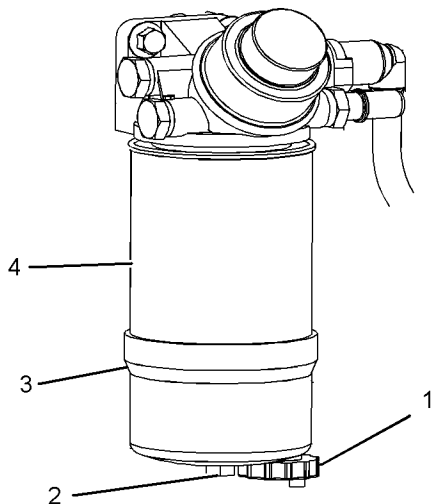

Illustration 56 g01259363

Typical example

3. Install a suitable tube onto drain (1). Open the drain (1). Allow the fluid to drain into the container. Remove the tube.
4. Tighten drain (1) by hand pressure only.
5. If equipped, remove the wiring harness from the sensor on the bottom of the glass bowl.
6. Hold glass bowl (3) and remove screw (2). Remove glass bowl (3) from canister (4).
7. Use a suitable tool in order to remove canister (4). Discard the old seals (5 and 6) and the canister in a safe place.
8. Clean glass bowl (3).

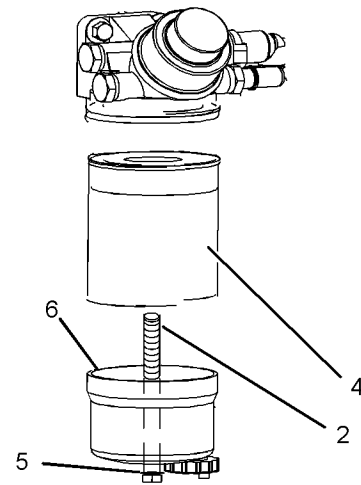

Illustration 57

g01259366

Typical example

9. Install the new canister. Do not use a tool in order to install the canister. Tighten the canister by hand.
10. Install new O ring seal (5) onto setscrew (2). Install new O ring seal (6) into the glass bowl.
11. Align the glass bowl to the canister. Ensure that the sensor (if equipped) is in the correct position. Install setscrew (2). Tighten the setscrew to a torque of 5 N·m (44 lb in).
12. If equipped, install the wiring harness to the sensor.
13. Remove the container and dispose of the fuel in a safe place.
14. The secondary filter must be replaced at the same time as the primary filter. Refer to the Operation and Maintenance Manual , "Fuel System Filter - Replace".

Type Two Filter

Note: Refer to Testing and Adjusting Manual , "Cleanliness of Fuel System Components" for detailed information on the standards of cleanliness that must be observed during ALL work on the fuel system.

After the engine has stopped, you must wait for 60 seconds in order to allow the fuel pressure to be purged from the high pressure fuel lines before any service or repair is performed on the engine fuel lines. If necessary, perform minor adjustments. Repair any leaks from the low pressure fuel system and from the cooling, lubrication or air systems. Replace any high pressure fuel line that has leaked. Refer to Disassembly and assembly Manual, "Fuel Injection Lines - Install".

NOTICE

Ensure that the engine is stopped before any servicing or repair is performed.

1. Turn the fuel supply valve (if equipped) to the OFF position before performing this maintenance.
2. Place a suitable container under the water separator in order to catch any fuel that might spill. Clean up any spilled fuel. Clean the outside of the water separator.

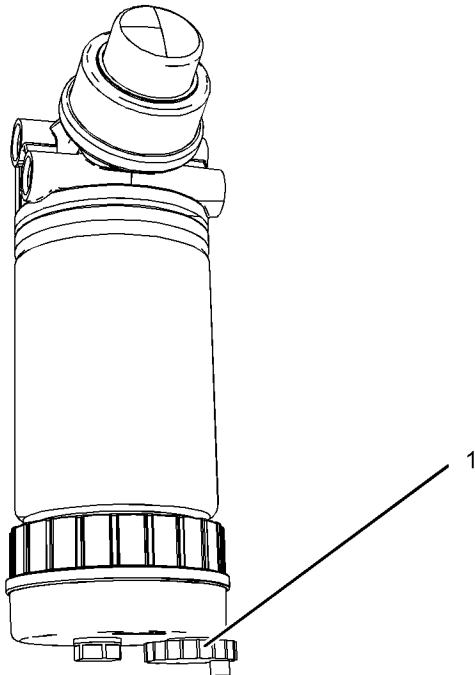

Illustration 58

g01429124

3. Install a suitable tube onto drain (1). Open drain (1). Allow the fluid to drain into the container. Remove the tube.
4. Tighten drain (1) by hand pressure only.
5. If equipped, remove the wiring harness from the sensor on the bottom of the bowl .

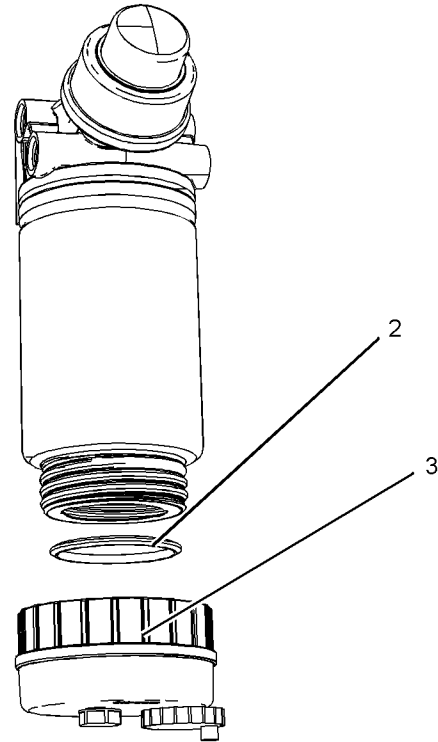

Illustration 59

g01429125

6. Rotate bowl (3) counterclockwise in order to remove the bowl. Remove O ring seal (2). Clean the bowl.

Maintenance Section
 Fuel System Primary Filter (Water Separator) Element - Replace

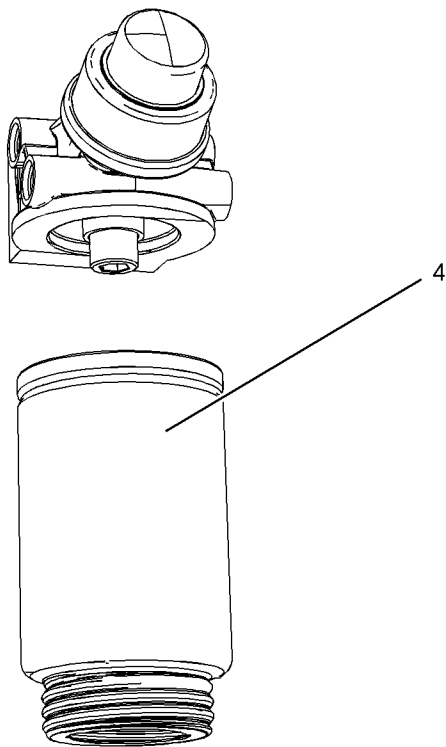

Illustration 60

g01429126

- 7.** Use a suitable tool in order to remove old canister (4).

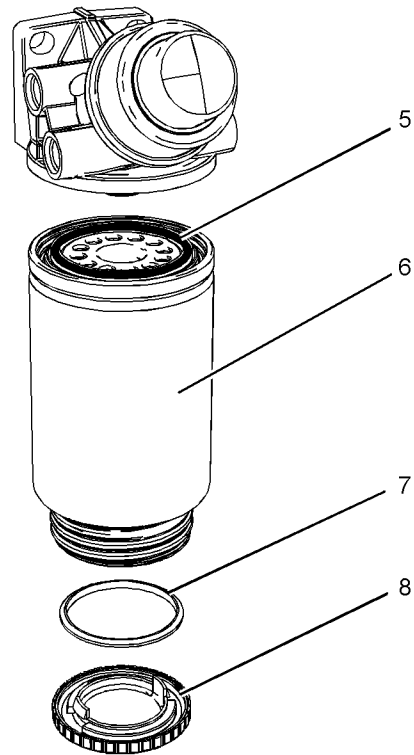

Illustration 61

g01429127

- 8.** Lubricate O ring seal (5) with clean engine oil on the new canister. Install new canister (6). Spin on the canister until the O ring seal contacts the sealing surface. Then rotate the canister 360 degree in order to tighten the canister correctly.
- 9.** Remove cap (8) from the threaded end of the new canister and remove new O ring seal (7). Install the new O ring seal into bowl (3).
- 10.** Lubricate O ring seal (7) with clean engine oil. Install the bowl onto the new canister. Tighten the bowl to 15 N·m (11 lb ft).
- 11.** If equipped, install the wiring harness to the sensor. Open the fuel supply valve.
- 12.** Remove the container and dispose of the fluid in a safe place.

13. The secondary filter must be replaced at the same time as the primary filter. Refer to the Operation and Maintenance Manual , “Fuel System Filter - Replace”.

i02869410

Fuel System Primary Filter/ Water Separator - Drain

WARNING

Fuel leaked or spilled onto hot surfaces or electrical components can cause a fire. To help prevent possible injury, turn the start switch off when changing fuel filters or water separator elements. Clean up fuel spills immediately.

NOTICE

Ensure that the engine is stopped before any servicing or repair is performed.

After the engine has stopped, you must wait for 60 seconds in order to allow the fuel pressure to be purged from the high pressure fuel lines before any service or repair is performed on the engine fuel lines. If necessary, perform minor adjustments. Repair any leaks from the low pressure fuel system and from the cooling, lubrication or air systems. Replace any high pressure fuel line that has leaked. Refer to Disassembly and Assembly Manual, “Fuel Injection Lines - Install”.

NOTICE

The water separator can be under suction during normal engine operation. Ensure that the drain valve is tightened securely to help prevent air from entering the fuel system.

1. Place a suitable container under the water separator in order to catch any fuel that might spill. Clean up any spilled fuel.

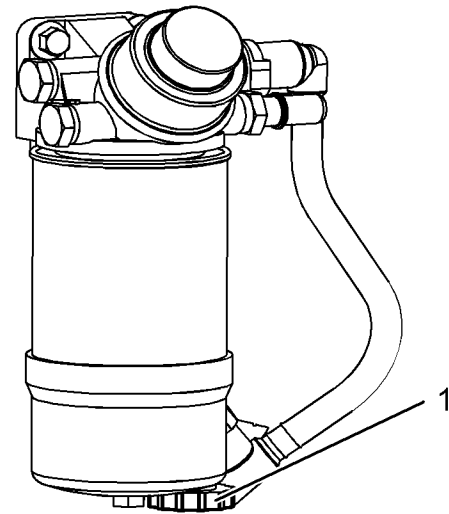

Illustration 62

g01476633

Typical example

2. Install a suitable tube onto the drain (1). Open the drain (1). Allow the fluid to drain into the container.
3. Tighten the drain (1) by hand pressure only. Remove the tube and dispose of the drained fluid in a safe place.

Primary Filter with a Vent Screw

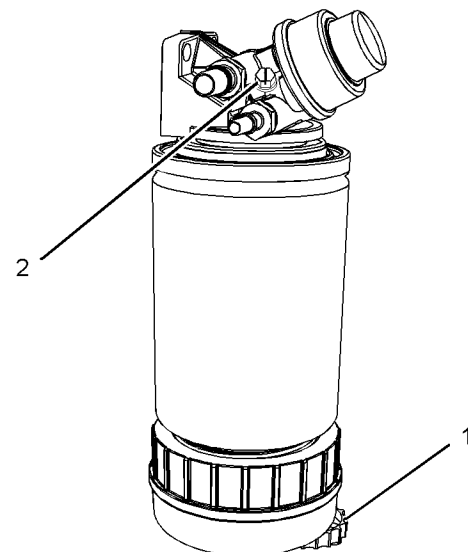

Illustration 63

g01371846

Typical example

Note: Not all primary filters require vent screw (2). This primary fuel filter that has a vent screw may be installed on a fuel system that has a low fuel tank.

1. Install a suitable tube onto drain (1). Loosen vent screw (2).
2. Open drain (1). Allow the fluid to drain into the container.
3. Tighten drain (1) by hand pressure only. Remove the tube and dispose of the drained fluid in a safe place.
4. Tighten vent screw to 6 N·m (53 lb in).

i02869989

Fuel System Secondary Filter - Replace

Type One

WARNING

Fuel leaked or spilled onto hot surfaces or electrical components can cause a fire. To help prevent possible injury, turn the start switch off when changing fuel filters or water separator elements. Clean up fuel spills immediately.

Note: Refer to Testing and Adjusting Manual , “Cleanliness of Fuel System Components” for detailed information on the standards of cleanliness that must be observed during ALL work on the fuel system.

NOTICE

Ensure that the engine is stopped before any servicing or repair is performed.

This fuel filter can be identified by the six drain holes in the filter. Refer to illustration 64 .

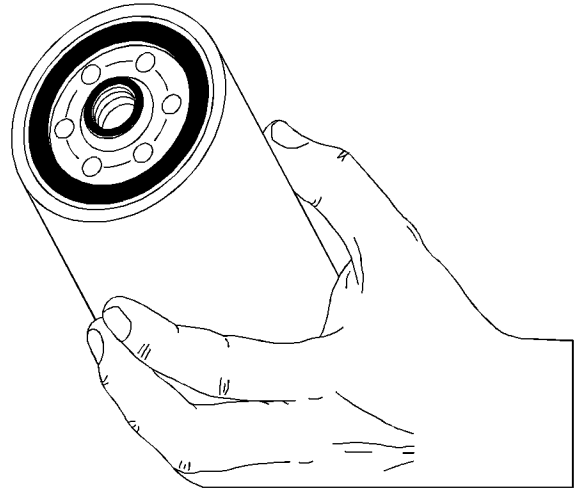

Illustration 64

g01429525

Typical example

After the engine has stopped, you must wait for 60 seconds in order to allow the fuel pressure to be purged from the high pressure fuel lines before any service or repair is performed on the engine fuel lines. If necessary, perform minor adjustments. Repair any leaks from the low pressure fuel system and from the cooling, lubrication or air systems. Replace any high pressure fuel line that has leaked. Refer to Disassembly and Assembly Manual, “Fuel Injection Lines - Install”.

1. Ensure that the fuel supply valve (if equipped) is in the OFF position. Place a suitable container under the fuel filter in order to catch any fuel that might spill. Clean up any spilled fuel.

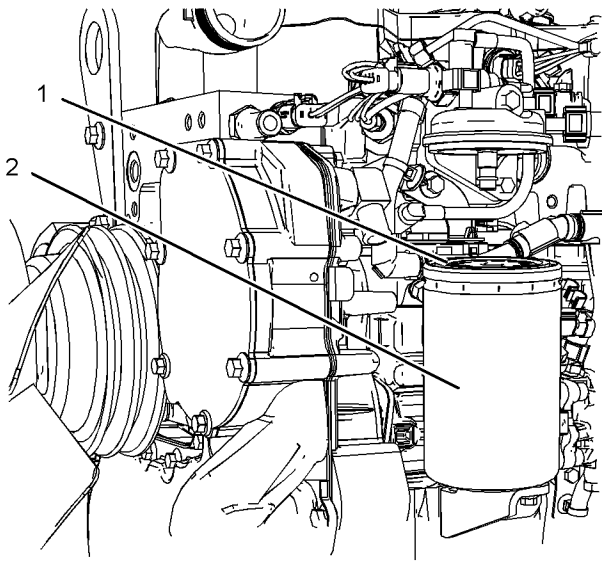

Illustration 65

g01429517

Typical example

2. Clean the outside of the fuel filter. Use a suitable tool in order to remove the canister (2) from the engine and dispose of the canister in a safe place.
3. Ensure that dirt can not enter the new canister. Do not fill the canister with fuel before the canister is installed. Lubricate the O ring seal (1) with clean engine oil on the new canister.
4. Install the new canister. Do not use a tool in order to install the canister. Tighten the canister by hand.
5. Spin on the canister until the O ring seal contacts the sealing surface. The canister will require a $\frac{3}{4}$ of a full turn in order to tighten the canister correctly.
6. Prime the fuel system. Refer to the Operation and Maintenance Manual, "Fuel System - Prime" for more information.

Type Two

WARNING

Fuel leaked or spilled onto hot surfaces or electrical components can cause a fire. To help prevent possible injury, turn the start switch off when changing fuel filters or water separator elements. Clean up fuel spills immediately.

Note: Refer to Testing and Adjusting Manual , "Cleanliness of Fuel System Components" for detailed information on the standards of cleanliness that must be observed during ALL work on the fuel system.

NOTICE

Ensure that the engine is stopped before any servicing or repair is performed.

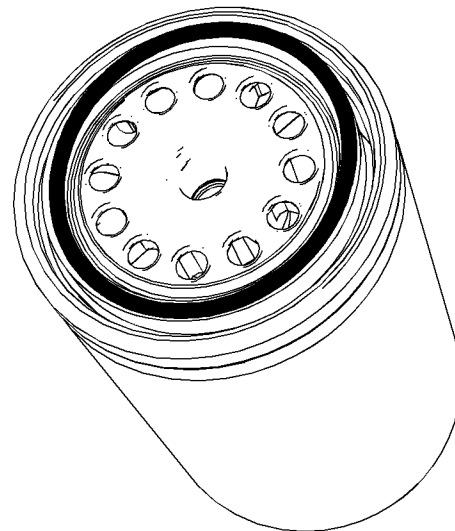

Illustration 66

g01429532

This fuel filter can be identified by the 12 drain holes in the filter. Refer to illustration 66 .

After the engine has stopped, you must wait for 60 seconds in order to allow the fuel pressure to be purged from the high pressure fuel lines before any service or repair is performed on the engine fuel lines. If necessary, perform minor adjustments. Repair any leaks from the low pressure fuel system and from the cooling, lubrication or air systems. Replace any high pressure fuel line that has leaked. Refer to Disassembly and Assembly Manual, "Fuel Injection Lines - Install".

1. Ensure that the fuel supply valve (if equipped) is in the OFF position. Place a suitable container under the fuel filter in order to catch any fuel that might spill. Clean up any spilled fuel.

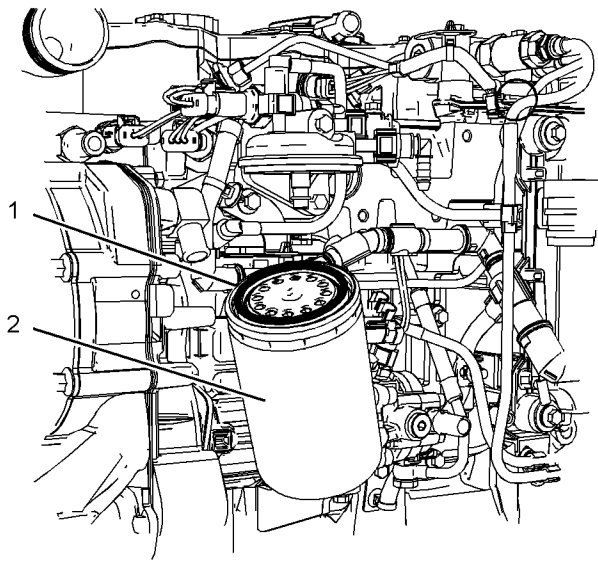

Illustration 67

g01429516

Typical example

2. Clean the outside of the fuel filter. Use a suitable tool in order to remove the canister (2) from the engine and dispose of the canister in a safe place.
3. Ensure that dirt can not enter the new canister. Do not fill the canister with fuel before the canister is installed. Lubricate the O ring seal (1) with clean engine oil on the new canister.
4. Install the new canister. Do not use a tool in order to install the canister. Tighten the canister by hand.
5. Spin on the canister until the O ring seal contacts the sealing surface. Then rotate the canister 360 degree in order to tighten the canister correctly.
6. Remove the container and dispose of the fuel in a safe place. If equipped, open the fuel supply valve.

7. Prime the fuel system. Refer to the Operation and Maintenance Manual, "Fuel System - Prime" for more information.

i02335436

Fuel Tank Water and Sediment - Drain

NOTICE

Care must be taken to ensure that fluids are contained during performance of inspection, maintenance, testing, adjusting and repair of the product. Be prepared to collect the fluid with suitable containers before opening any compartment or disassembling any component containing fluids.

Dispose of all fluids according to local regulations and mandates.

Fuel Tank

Fuel quality is critical to the performance and to the service life of the engine. Water in the fuel can cause excessive wear to the fuel system.

Water can be introduced into the fuel tank when the fuel tank is being filled.

Condensation occurs during the heating and cooling of fuel. The condensation occurs as the fuel passes through the fuel system and the fuel returns to the fuel tank. This causes water to accumulate in fuel tanks. Draining the fuel tank regularly and obtaining fuel from reliable sources can help to eliminate water in the fuel.

Drain the Water and the Sediment

Fuel tanks should contain some provision for draining water and draining sediment from the bottom of the fuel tanks.

Open the drain valve on the bottom of the fuel tank in order to drain the water and the sediment. Close the drain valve.

Check the fuel daily. Allow five minutes after the fuel tank has been filled before draining water and sediment from the fuel tank.

Fill the fuel tank after operating the engine in order to drive out moist air. This will help prevent condensation. Do not fill the tank to the top. The fuel expands as the fuel gets warm. The tank may overflow.

Some fuel tanks use supply pipes that allow water and sediment to settle below the end of the fuel supply pipe. Some fuel tanks use supply lines that take fuel directly from the bottom of the tank. If the engine is equipped with this system, regular maintenance of the fuel system filter is important.

Fuel Storage Tanks

Drain the water and the sediment from the fuel storage tank at the following intervals:

- Weekly
- Service intervals
- Refill of the tank

This will help prevent water or sediment from being pumped from the storage tank into the engine fuel tank.

If a bulk storage tank has been refilled or moved recently, allow adequate time for the sediment to settle before filling the engine fuel tank. Internal baffles in the bulk storage tank will also help trap sediment. Filtering fuel that is pumped from the storage tank helps to ensure the quality of the fuel. When possible, water separators should be used.

i02349879

Hoses and Clamps - Inspect/Replace

WARNING

Contact with high pressure fuel may cause fluid penetration and burn hazards. High pressure fuel spray may cause a fire hazard. Failure to follow these inspection, maintenance and service instructions may cause personal injury or death.

If you inspect the engine in operation, always use the proper inspection procedure in order to avoid a fluid penetration hazard. Refer to Operation and Maintenance Manual, "General hazard Information".

Inspect all hoses for leaks that are caused by the following conditions:

- Cracking
- Softness
- Loose clamps

Replace hoses that are cracked or soft. Tighten any loose clamps.

Check for the following conditions:

- End fittings that are damaged or leaking
- Outer covering that is chafed or cut
- Exposed wire that is used for reinforcement
- Outer covering that is ballooning locally
- Flexible part of the hose that is kinked or crushed
- Armoring that is embedded in the outer covering

A constant torque hose clamp can be used in place of any standard hose clamp. Ensure that the constant torque hose clamp is the same size as the standard clamp.

Due to extreme temperature changes, the hose will harden. Hardening of the hoses will cause hose clamps to loosen. This can result in leaks. A constant torque hose clamp will help to prevent loose hose clamps.

Each installation application can be different. The differences depend on the following factors:

- Type of hose
- Type of fitting material
- Anticipated expansion and contraction of the hose
- Anticipated expansion and contraction of the fittings

Replace the Hoses and the Clamps

Refer to the OEM information for further information on removing and replacing fuel hoses (if equipped).

The coolant system and the hoses for the coolant system are not usually supplied by Perkins. The following text describes a typical method of replacing coolant hoses. Refer to the OEM information for further information on the coolant system and the hoses for the coolant system.

WARNING

Pressurized System: Hot coolant can cause serious burns. To open the cooling system filler cap, stop the engine and wait until the cooling system components are cool. Loosen the cooling system pressure cap slowly in order to relieve the pressure.

1. Stop the engine. Allow the engine to cool.
2. Loosen the cooling system filler cap slowly in order to relieve any pressure. Remove the cooling system filler cap.

Note: Drain the coolant into a suitable, clean container. The coolant can be reused.

3. Drain the coolant from the cooling system to a level that is below the hose that is being replaced.
4. Remove the hose clamps.
5. Disconnect the old hose.
6. Replace the old hose with a new hose.
7. Install the hose clamps with a torque wrench.

Note: For the correct coolant, see this Operation and Maintenance Manual, "Fluid Recommendations".

8. Refill the cooling system. Refer to the OEM information for further information on refilling the cooling system.
9. Clean the cooling system filler cap. Inspect the cooling system filler cap's seals. Replace the cooling system filler cap if the seals are damaged. Install the cooling system filler cap.
10. Start the engine. Inspect the cooling system for leaks.

i02335774

Radiator - Clean

The radiator is not usually supplied by Perkins. The following text describes a typical cleaning procedure for the radiator. Refer to the OEM information for further information on cleaning the radiator.

Note: Adjust the frequency of cleaning according to the effects of the operating environment.

Inspect the radiator for these items: Damaged fins, corrosion, dirt, grease, insects, leaves, oil and other debris. Clean the radiator, if necessary.

WARNING

Personal injury can result from air pressure.

Personal injury can result without following proper procedure. When using pressure air, wear a protective face shield and protective clothing.

Maximum air pressure at the nozzle must be less than 205 kPa (30 psi) for cleaning purposes.

Pressurized air is the preferred method for removing loose debris. Direct the air in the opposite direction to the fan's air flow. Hold the nozzle approximately 6 mm (0.25 inch) away from the radiator fins. Slowly move the air nozzle in a direction that is parallel with the radiator tube assembly. This will remove debris that is between the tubes.

Pressurized water may also be used for cleaning. The maximum water pressure for cleaning purposes must be less than 275 kPa (40 psi). Use pressurized water in order to soften mud. Clean the core from both sides.

Use a degreaser and steam for removal of oil and grease. Clean both sides of the core. Wash the core with detergent and hot water. Thoroughly rinse the core with clean water.

If the radiator is blocked internally, refer to the OEM Manual for information regarding flushing the cooling system.

After cleaning the radiator, start the engine. Allow the engine to operate at low idle speed for three to five minutes. Accelerate the engine to high idle. This will help in the removal of debris and the drying of the core. Slowly reduce the engine speed to low idle and then stop the engine. Use a light bulb behind the core in order to inspect the core for cleanliness. Repeat the cleaning, if necessary.

Inspect the fins for damage. Bent fins may be opened with a "comb". Inspect these items for good condition: Welds, mounting brackets, air lines, connections, clamps and seals. Make repairs, if necessary.

i02335775

Severe Service Application - Check

Severe service is the application of an engine that exceeds the current published standards for that engine. Perkins maintains standards for the following engine parameters:

- Performance such as power range, speed range, and fuel consumption
- Fuel quality
- Operational Altitude
- Maintenance intervals
- Oil selection and maintenance
- Coolant type and maintenance
- Environmental qualities
- Installation
- The temperature of the fluid in the engine

Refer to the standards for the engine or consult your Perkins dealer or your Perkins distributor in order to determine if the engine is operating within the defined parameters.

Severe service operation can accelerate component wear. Engines that operate under severe conditions may need more frequent maintenance intervals in order to ensure maximum reliability and retention of full service life.

Due to individual applications, it is not possible to identify all of the factors which can contribute to severe service operation. Consult your Perkins dealer or your Perkins distributor for the unique maintenance that is necessary for the engine.

The operating environment, incorrect operating procedures and incorrect maintenance procedures can be factors which contribute to a severe service application.

Environmental Factors

Ambient temperatures – The engine may be exposed to extended operation in extremely cold environments or hot environments. Valve components can be damaged by carbon buildup if the engine is frequently started and stopped in very cold temperatures. Extremely hot intake air reduces engine performance.

Quality of the air – The engine may be exposed to extended operation in an environment that is dirty or dusty, unless the equipment is cleaned regularly. Mud, dirt and dust can encase components. Maintenance can be very difficult. The buildup can contain corrosive chemicals.

Buildup – Compounds, elements, corrosive chemicals and salt can damage some components.

Altitude – Problems can arise when the engine is operated at altitudes that are higher than the intended settings for that application. Necessary adjustments should be made.

Incorrect Operating Procedures

- Extended operation at low idle
- Frequent hot shutdowns
- Operating at excessive loads
- Operating at excessive speeds
- Operating outside the intended application

Incorrect Maintenance Procedures

- Extending the maintenance intervals

- Failure to use recommended fuel, lubricants and coolant/antifreeze

i07888480

Starting Motor - Inspect

Perkins recommends a scheduled inspection of the starting motor. If the starting motor fails, the engine may not start in an emergency situation.

Check the starting motor for correct operation. Check the electrical connections and clean the electrical connections. Refer to the Systems Operation, Testing and Adjusting Manual, "Electric Starting System - Test" for more information on the checking procedure and for specifications consult your Perkins dealer or your Perkins distributor for assistance.

i04149590

Turbocharger - Inspect

A regular visual inspection of the turbocharger is recommended. If the turbocharger fails during engine operation, damage to the turbocharger compressor wheel and/or to the engine may occur. Damage to the turbocharger compressor wheel can cause additional damage to the pistons, the valves, and the cylinder head.

NOTICE

Turbocharger bearing failures can cause large quantities of oil to enter the air intake and exhaust systems. Loss of engine lubricant can result in serious engine damage.

Minor leakage of oil into a turbocharger under extended low idle operation should not cause problems as long as a turbocharger bearing failure has not occurred.

When a turbocharger bearing failure is accompanied by a significant engine performance loss (exhaust smoke or engine rpm up at no load), do not continue engine operation until the turbocharger is renewed.

A visual inspection of the turbocharger can minimize unscheduled downtime. A visual inspection of the turbocharger can also reduce the chance for potential damage to other engine parts.

Removal and Installation

For options regarding the removal, installation, and replacement, consult your Perkins dealer or your Perkins distributor. Refer to the Disassembly and Assembly, "Turbocharger - Remove and Turbocharger - Install" and Systems Operation, Testing and Adjusting, "Turbocharger - Inspect" for further information.

Inspecting

NOTICE

The compressor housing for the turbocharger must not be removed from the turbocharger for inspection or removed for the cleaning of the compressor.

1. Remove the pipe from the turbocharger exhaust outlet and remove the air intake pipe to the turbocharger. Visually inspect the piping for the presence of oil. Clean the interior of the pipes in order to prevent dirt from entering during reassembly.
2. Check for obvious heat discoloration of the turbocharger. Check for any loose bolts or any missing bolts. Check for damage to the oil supply line and the oil drain line. Check for cracks in the housing of the turbocharger. Ensure that the compressor wheel can rotate freely.
3. Check for the presence of oil. If oil is leaking from the back side of the compressor wheel, there is a possibility of a failed turbocharger oil seal.

The presence of oil may be the result of extended engine operation at low idle. The presence of oil may also be the result of a restriction of the line for the intake air (clogged air filters), which causes the turbocharger to slobber.
4. Inspect the bore of the housing of the turbine outlet for corrosion.

5. Fasten the air intake pipe and the exhaust outlet pipe to the turbocharger housing. Ensure that all clamps are installed correctly and that all clamps are tightened securely.

i02866087

V-Belts - Inspect/Adjust/Replace

Inspection

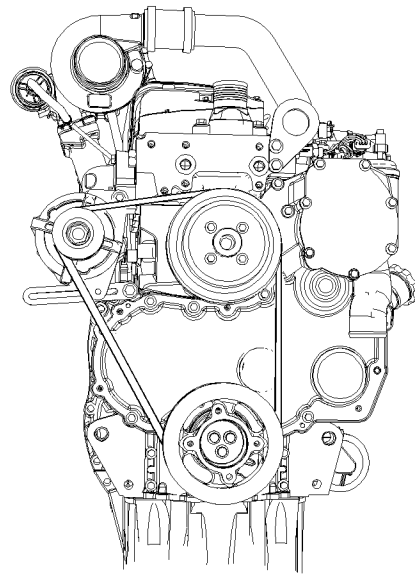

Illustration 68

g01249073

Arrangement for the V-belts

To maximize the engine performance, inspect the belts for wear and for cracking. Replace belts that are worn or damaged.

For applications that require multiple drive belts, replace the belts in matched sets. Replacing only one belt of a matched set will cause the new belt to carry more load because the older belt is stretched. The additional load on the new belt could cause the new belt to break.

If the belts are too loose, vibration causes unnecessary wear on the belts and pulleys. Loose belts may slip enough to cause overheating.

To accurately check the belt tension, a suitable gauge should be used.

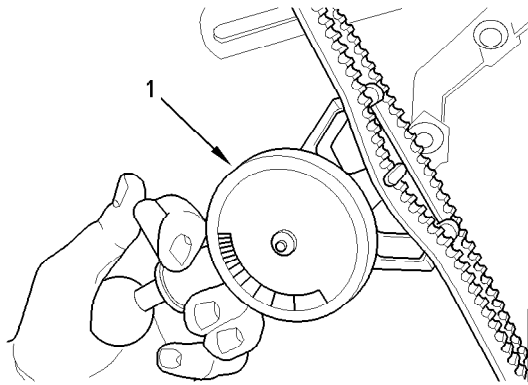

Illustration 69

g01003936

Typical example

(1) Belt tension gauge

Fit the gauge (1) at the center of the longest free length and check the tension. The correct tension for a used belt is 355 N (79.8 lb). If the tension of the belt is below 250 N (56 lb) adjust the belt to 355 N (79.8 lb).

Note: The correct tension for a new belt or new belts is 535 N (120 lb). A higher tension is required in order to compensate for the stretch that is in a new belt. Only use the higher tension on a belt that has not been used. A used belt is a belt that has been in operation for 30 minutes or a longer period of time.

If twin belts are installed, check and adjust the tension on both belts.

Adjustment

Illustration 70

g01427780

Typical example

1. Loosen nut (2) and the bolt (3).
2. Move the alternator in order to increase or decrease the belt tension. Tighten the nut (2) and the bolt (3) to 22 N·m (16 lb ft).(1).

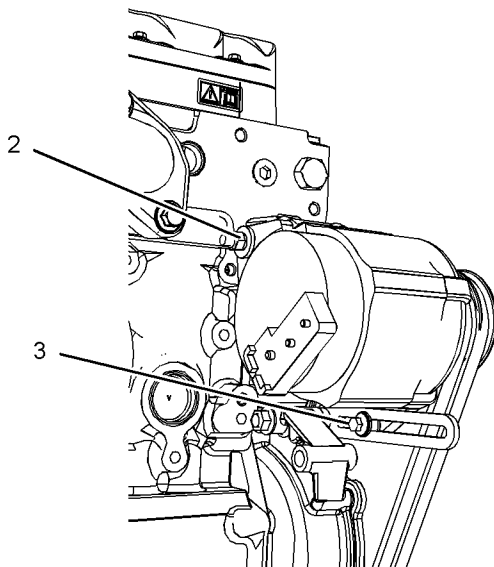
Replace

Refer to Disassembly and Assembly manual, "V-Belts - Remove and Install" for more information.

i03577563

Walk-Around Inspection**Inspect the Tube of the Crankcase Breather**

Illustration 71

g01905095

Inspect the breather tube (1) for damage. Ensure that the outlet (2) is clean and free from any obstructions. Ice can cause obstructions in adverse weather conditions.

Inspect the Engine for Leaks and for Loose Connections

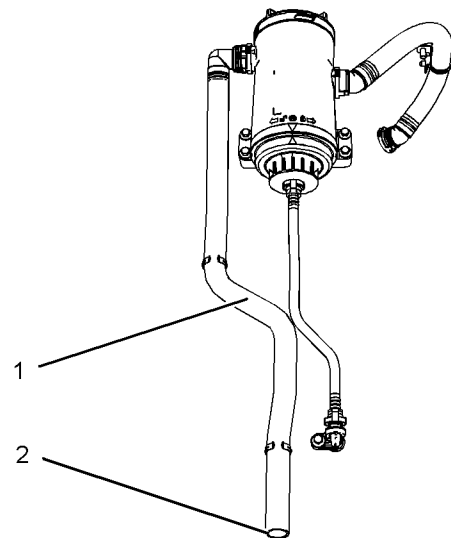
A walk-around inspection should only take a few minutes. When the time is taken to perform these checks, costly repairs and accidents can be avoided.

For maximum engine service life, make a thorough inspection of the engine compartment before starting the engine. Look for items such as oil leaks or coolant leaks, loose bolts, worn belts, loose connections and trash buildup. Make repairs, as needed:

Maintenance Section
Walk-Around Inspection

- The guards must be in the correct place. Repair damaged guards or replace missing guards.
- Wipe all caps and plugs before the engine is serviced in order to reduce the chance of system contamination.

NOTICE

For any type of leak (coolant, lube, or fuel) clean up the fluid. If leaking is observed, find the source and correct the leak. If leaking is suspected, check the fluid levels more often than recommended until the leak is found or fixed, or until the suspicion of a leak is proved to be unwarranted.

NOTICE

Accumulated grease and/or oil on an engine is a fire hazard. Remove the accumulated grease and oil. Refer to this Operation and Maintenance Manual, "Engine - Clean" for more information.

- Ensure that the cooling system hoses are correctly clamped and that the cooling system hoses are tight. Check for leaks. Check the condition of all pipes.
- Inspect the water pump for coolant leaks.

Note: The water pump seal is lubricated by the coolant in the cooling system. It is normal for a small amount of leakage to occur as the engine cools down and the parts contract.

Excessive coolant leakage may indicate the need to replace the water pump. Remove the water pump. Refer to Disassembly and Assembly, "Water Pump - Remove and Install". For more information, consult your Perkins dealer or your Perkins distributor.

- Inspect the lubrication system for leaks at the front crankshaft seal, the rear crankshaft seal, the oil pan, the oil filters and the rocker cover.
- Inspect the piping for the air intake system and the elbows for cracks and for loose clamps. Ensure that hoses and tubes are not contacting other hoses, tubes, wiring harnesses, etc.
- Ensure that the areas around the rotating parts are clear.
- Inspect the alternator belts and any accessory drive belts for cracks, breaks or other damage.
- Inspect the wiring harness for damage.

Belts for multiple groove pulleys must be replaced as matched sets. If only one belt is replaced, the belt will carry more load than the belts that are not replaced. The older belts are stretched. The additional load on the new belt could cause the belt to break.

High Pressure Fuel Lines

 **WARNING**

Contact with high pressure fuel may cause fluid penetration and burn hazards. High pressure fuel spray may cause a fire hazard. Failure to follow these inspection, maintenance and service instructions may cause personal injury or death.

After the engine has stopped, you must wait for 10 minutes in order to allow the fuel pressure to be purged from the high pressure fuel lines before any service or repair is performed on the engine fuel lines. If necessary, perform minor adjustments. Repair any leaks from the low pressure fuel system and from the cooling, lubrication or air systems. Replace any high pressure fuel line that has leaked. Refer to Disassembly and assembly Manual, "Fuel Injection Lines - Install".

If you inspect the engine in operation, always use the proper inspection procedure in order to avoid a fluid penetration hazard. Refer to Operation and Maintenance Manual, "General hazard Information".

Visually inspect the high pressure fuel lines for damage or signs of fuel leakage. Replace any damaged high pressure fuel lines or high pressure fuel lines that have leaked.

Ensure that all clips on the high pressure fuel lines are in place and that the clips are not loose.

- Inspect the rest of the fuel system for leaks. Look for loose fuel line clamps.
- Drain the water and the sediment from the fuel tank on a daily basis in order to ensure that only clean fuel enters the fuel system.
- Inspect the wiring and the wiring harnesses for loose connections and for worn wires or frayed wires. Check for any loose tie-wraps or missing tie-wraps.
- Inspect the ground strap for a good connection and for good condition.
- Disconnect any battery chargers that are not protected against the current drain of the starting motor. Check the condition and the electrolyte level of the batteries, unless the engine is equipped with a maintenance free battery.

- Check the condition of the gauges. Replace any gauges that are cracked. Replace any gauge that can not be calibrated.

i02499304

Water Pump - Inspect

A failed water pump may cause severe engine overheating problems that could result in the following conditions:

- Cracks in the cylinder head
- A piston seizure
- Other potential damage to the engine

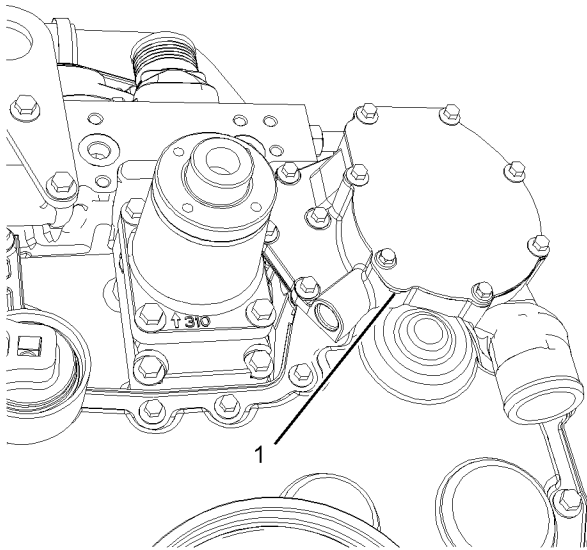

Illustration 72

g01249453

(1) Weep hole

Note: The water pump seal is lubricated by the coolant in the cooling system. It is normal for a small amount of leakage to occur as the engine cools down and parts contract.

Visually inspect the water pump for leaks. The water pump is not a serviceable item. In order to install a new water pump, refer to the Disassembly and Assembly Manual, "Water Pump - Remove and Install".

Warranty Section

Warranty Information

i06590874

Emissions Warranty Information

This engine may be certified to comply with exhaust emission and gaseous emission standards that are prescribed by the law at the time of manufacture. This engine may be covered by an Emissions Warranty. Consult your authorized Perkins dealer or distributor to determine if your engine is emissions certified and if your engine is subject to an Emissions Warranty.

Index

A

After Starting Engine	43
After Stopping Engine	45
Aftercooler Core - Clean/Test.....	71
Aftercooler Core - Inspect	71
Alternator - Inspect	72
Alternator Belt - Inspect/Adjust/Replace (Poly V-Belt).....	72
Adjustment.....	72
Inspection	72
Replace.....	72

B

Battery - Replace.....	72
Battery Electrolyte Level - Check	73
Battery or Battery Cable - Disconnect.....	73
Before Starting Engine	17, 42
Belt Tensioner - Inspect.....	74
Burn Prevention.....	12
Batteries.....	13
Coolant	12
Diesel Fuel.....	12
Oils.....	12
Viton Seals.....	12

C

Cold Weather Operation	47
Hints for Cold Weather Operation	47
Idling the Engine	48
Recommendations for Coolant Warm Up....	48
Recommendations for the Coolant.....	48
Viscosity of the Engine Lubrication Oil	48
Cooling System Coolant (Commercial Heavy-Duty) - Change.....	74
Drain	74
Fill	75
Flush	75
Cooling System Coolant (ELC) - Change	76
Drain	76
Fill	77
Flush	77
Cooling System Coolant Level - Check.....	78
Engines With a Coolant Recovery Tank	78
Engines Without a Coolant Recovery Tank.....	78
Cooling System Supplemental Coolant Additive (SCA) - Test/Add.....	79

Add the SCA, If Necessary	79
Test for SCA Concentration	79
Crankcase Breather (Canister) - Replace.....	80
Crushing Prevention and Cutting Prevention..	15

D

Diagnostic Flash Code Retrieval.....	38
“Diagnostic” Lamp	38
Diagnostic Lamp.....	38
Driven Equipment - Check	80

E

Electrical System.....	18
Grounding Practices	18
Emergency Stopping.....	45
Emissions Certification Film	26
Emissions Warranty Information	106
Engine - Clean.....	80
Engine Air Cleaner Element (Dual Element) - Clean/Replace.....	81
Cleaning the Primary Air Cleaner Elements	82
Servicing the Air Cleaner Elements.....	81
Engine Air Cleaner Service Indicator - Inspect	83
Test the Service Indicator	83
Engine Air Precleaner - Check/Clean (If Equipped)	84
Engine Description	22
Electronic Engine Features	23
Engine Cooling and Lubrication	23
Engine Diagnostics.....	23
Engine Specifications	22
Engine Diagnostics	38
Engine Electronics.....	19
Engine Lifting.....	27
Engine Only	28
Engines with Factory Installed Radiators	28
Engine Mounts - Inspect.....	84
Engine Oil and Filter - Change	85
Drain the Engine Lubricating Oil.....	86
Fill the Oil Pan.....	87
Horizontal Oil Filter	87
Replace the Oil Filter	86
Engine Oil and Filter - Change (CG-4 Oil)	88
Engine Oil Level - Check.....	84
Engine Oil Sample - Obtain.....	85

Obtain the Sample and the Analysis	85	Hand Fuel Priming Pump	91
Engine Operation	44	Fuel System Primary Filter (Water Separator) Element - Replace	91
Engine Operation with Active Diagnostic Codes	40	Type One Filter	91
Engine Operation with Intermittent Diagnostic Codes	40	Type Two Filter	92
Engine Shutoffs and Engine Alarms	36	Fuel System Primary Filter/Water Separator - Drain	95
Alarms	36	Primary Filter with a Vent Screw	95
Shutoffs	36	Fuel System Secondary Filter - Replace	96
Testing	37	Type One	96
Engine Starting	17, 42	Type Two	97
Engine Stopping	18, 45	Fuel Tank Water and Sediment - Drain	98
Engine Storage	28	Drain the Water and the Sediment	98
Engine Valve Lash - Inspect/Adjust	88	Fuel Storage Tanks	99
Exhaust Manifold - Inspect	89	Fuel Tank	98
F		G	
Fan Clearance - Check	89	Gauges and Indicators	30
Fault Logging	40	General Hazard Information	9
Features and Controls	31	Containing Fluid Spillage	10
Fire Prevention and Explosion Prevention	13	Fluid Penetration	10
Fire Extinguisher	14	Inhalation	11
Lines, Tubes, and Hoses	14	Pressure Air and Water	9
Fluid Recommendations	58	Static Electricity Hazard when Fueling with Ultra-low Sulfur Diesel Fuel	10
Engine Oil	58		
General Lubricant Information	58	H	
Fluid Recommendations (Coolant Specifications)	62	High Pressure Fuel Lines	15
ELC Cooling System Maintenance	64	Hoses and Clamps - Inspect/Replace	99
General Coolant Information	62	Replace the Hoses and the Clamps	99
Fluid Recommendations (Fuel Specification)	52		
Diesel Fuel Characteristics	54	I	
Diesel Fuel Requirements	52	Important Safety Information	2
General Information	52		
Foreword	4	L	
California Proposition 65 Warning	4	Lifting and Storage	27
Literature Information	4		
Maintenance	4	M	
Maintenance Intervals	5	Maintenance Interval Schedule	69
Operation	4	Commissioning	70
Overhaul	5	Daily	69
Safety	4	Every 1000 Service Hours	69
Fuel and the Effect from Cold Weather	49	Every 12 000 Service Hours or 6 Years	70
Fuel Conservation Practices	44	Every 2000 Service Hours	69
Fuel Related Components in Cold Weather ...	50	Every 250 Service Hours	69
Fuel Filters	50	Every 3000 Service Hours	70
Fuel Heaters	50	Every 3000 Service Hours or 2 Years	70
Fuel Tanks	50	Every 4000 Service Hours	70
Fuel System - Prime	90		

Every 50 Service Hours or Weekly	69	Programmable Monitoring System (PMS)...	34
Every 500 Service Hours	69	Secondary Speed/Timing Sensor 7	36
Every 500 Service Hours or 1 Year	69	Sensor Locations	32
Initial 500 Service Hours	69	Severe Service Application - Check	100
When Required	69	Environmental Factors	101
Maintenance Recommendations	67	Incorrect Maintenance Procedures	101
Maintenance Section	51	Incorrect Operating Procedures	101
Model View Illustrations	20	Starting Motor - Inspect	101
Model Views	20	Starting the Engine	42
Monitoring System	31	Starting the Engine	42
Programmable Options and Systems		Starting with Jump Start Cables	42
Operation	31	Stopping the Engine	45
Mounting and Dismounting	15		
		T	
O		Table of Contents	3
Operation Section	27	Turbocharger - Inspect	101
Overspeed	37	Inspecting	102
		Removal and Installation	102
P			
Plate Locations and Film Locations	25	V	
Serial Number Plate (1)	25	V-Belts - Inspect/Adjust/Replace	102
Product Identification Information	25	Adjustment	103
Product Information Section	20	Inspection	102
		Replace	103
R			
Radiator - Clean	100	W	
Reference Numbers	25	Walk-Around Inspection	103
Record for Reference	25	High Pressure Fuel Lines	104
Refill Capacities	51	Inspect the Engine for Leaks and for Loose	
Cooling System	51	Connections	103
Lubrication System	51	Inspect the Tube of the Crankcase	
		Breather	103
S		Warranty Information	106
Safety Messages	6	Warranty Section	106
(1) Universal Warning	6	Water Pump - Inspect	105
(2) Hand (High Pressure)	7	Welding on Engines with Electronic	
(3) Ether	8	Controls	67
Safety Section	6		
Self-Diagnostics	38		
Sensors and Electrical Components	32		
Coolant Temperature Sensor 1	35		
Electronic Control Module 5	35		
Engine Oil Pressure Sensor 8	36		
Failure of Sensors	34		
Fuel Pressure Sensor 4	35		
Intake Manifold Air Temperature Sensor 2 ..	35		
Intake Manifold Pressure Sensor 3	35		
Primary Speed/Timing Sensor 6	35		

Product and Dealer Information

Note: For product identification plate locations, see the section "Product Identification Information" in the Operation and Maintenance Manual.

Delivery Date: _____

Product Information

Model: _____

Product Identification Number: _____

Engine Serial Number: _____

Transmission Serial Number: _____

Generator Serial Number: _____

Attachment Serial Numbers: _____

Attachment Information: _____

Customer Equipment Number: _____

Dealer Equipment Number: _____

Dealer Information

Name: _____ Branch: _____

Address: _____

Dealer Contact

Phone Number

Hours

Sales: _____

Parts: _____

Service: _____

