

# Operation and Maintenance Manual

---

## **854E-E34TA, 854F-E34T and 854F- E34TA Industrial Engines**

---

JR (Engine)  
JS (Engine)  
JT (Engine)  
JV (Engine)

## Important Safety Information

Most accidents that involve product operation, maintenance and repair are caused by failure to observe basic safety rules or precautions. An accident can often be avoided by recognizing potentially hazardous situations before an accident occurs. A person must be alert to potential hazards. This person should also have the necessary training, skills and tools to perform these functions correctly.

**Incorrect operation, lubrication, maintenance or repair of this product can be dangerous and could result in injury or death.**

**Do not operate or perform any lubrication, maintenance or repair on this product, until you have read and understood the operation, lubrication, maintenance and repair information.**

Safety precautions and warnings are provided in this manual and on the product. If these hazard warnings are not heeded, bodily injury or death could occur to you or to other persons.

The hazards are identified by the "Safety Alert Symbol" and followed by a "Signal Word" such as "DANGER", "WARNING" or "CAUTION". The Safety Alert "WARNING" label is shown below.



The meaning of this safety alert symbol is as follows:

**Attention! Become Alert! Your Safety is Involved.**

The message that appears under the warning explains the hazard and can be either written or pictorially presented.

Operations that may cause product damage are identified by "NOTICE" labels on the product and in this publication.

**Perkins cannot anticipate every possible circumstance that might involve a potential hazard. The warnings in this publication and on the product are, therefore, not all inclusive. You must not use this product in any manner different from that considered by this manual without first satisfying yourself that you have considered all safety rules and precautions applicable to the operation of the product in the location of use, including site-specific rules and precautions applicable to the worksite. If a tool, procedure, work method or operating technique that is not specifically recommended by Perkins is used, you must satisfy yourself that it is safe for you and for others. You should also ensure that you are authorized to perform this work, and that the product will not be damaged or become unsafe by the operation, lubrication, maintenance or repair procedures that you intend to use.**

The information, specifications, and illustrations in this publication are on the basis of information that was available at the time that the publication was written. The specifications, torques, pressures, measurements, adjustments, illustrations, and other items can change at any time. These changes can affect the service that is given to the product. Obtain the complete and most current information before you start any job. Perkins dealers or Perkins distributors have the most current information available.



**When replacement parts are required for this product Perkins recommends using Perkins replacement parts.**

**Failure to heed this warning can lead to premature failures, product damage, personal injury or death.**

---

**In the United States, the maintenance, replacement, or repair of the emission control devices and systems may be performed by any repair establishment or individual of the owner's choosing.**

## Table of Contents

Foreword .....	4
----------------	---

### Safety Section

Safety Messages .....	6
-----------------------	---

General Hazard Information .....	7
----------------------------------	---

Burn Prevention .....	11
-----------------------	----

Fire Prevention and Explosion Prevention .....	12
--	----

Crushing Prevention and Cutting Prevention ..	14
---	----

Mounting and Dismounting .....	14
--------------------------------	----

High Pressure Fuel Lines .....	15
--------------------------------	----

Before Starting Engine .....	16
------------------------------	----

Engine Starting .....	16
-----------------------	----

Engine Stopping .....	17
-----------------------	----

Electrical System .....	17
-------------------------	----

Engine Electronics .....	18
--------------------------	----

### Product Information Section

General Information .....	20
---------------------------	----

Product Identification Information .....	29
--	----

### Operation Section

Lifting and Storage .....	34
---------------------------	----

Features and Controls .....	36
-----------------------------	----

Engine Diagnostics .....	52
--------------------------	----

Engine Starting .....	56
-----------------------	----

Engine Operation .....	60
------------------------	----

Cold Weather Operation .....	64
------------------------------	----

Engine Stopping .....	68
-----------------------	----

### Maintenance Section

Refill Capacities .....	70
-------------------------	----

Maintenance Recommendations .....	85
-----------------------------------	----

Maintenance Interval Schedule .....	88
-------------------------------------	----

### Warranty Section

Warranty Information .....	118
----------------------------	-----

### Reference Information Section

Reference Materials .....	119
---------------------------	-----

### Index Section

Index .....	120
-------------	-----

## Foreword

### California Proposition 65 Warning

**Diesel engine exhaust and some of its constituents are known to the State of California to cause cancer, birth defects, and other reproductive harm.**



**WARNING – This product can expose you to chemicals including ethylene glycol, which is known to the State of California to cause birth defects or other reproductive harm. For more information go to:**

**[www.P65Warnings.ca.gov](http://www.P65Warnings.ca.gov)**

**Do not ingest this chemical. Wash hands after handling to avoid incidental ingestion.**



**WARNING – This product can expose you to chemicals including lead and lead compounds, which are known to the State of California to cause cancer, birth defects, or other reproductive harm. For more information go to:**

**[www.P65Warnings.ca.gov](http://www.P65Warnings.ca.gov)**

**Wash hands after handling components that may contain lead.**

### Literature Information

This manual contains safety, operation instructions, lubrication, and maintenance information. This manual should be stored in or near the engine area in a literature holder or literature storage area. Read, study, and keep the manual with the literature and engine information.

English is the primary language for all Perkins publications. The English used facilitates translation and consistency.

Some photographs or illustrations in this manual show details or attachments that may be different from your engine. Guards and covers may have been removed for illustrative purposes. Continuing improvement and advancement of product design may have caused changes to your engine which are not included in this manual. Whenever a question arises regarding your engine, or this manual, please consult with your Perkins dealer or your Perkins distributor for the latest available information.

### Safety

This safety section lists basic safety precautions. In addition, this section identifies hazardous, warning situations. Read and understand the basic precautions listed in the safety section before operating or performing lubrication, maintenance, and repair on this product.

### Operation

Operating techniques outlined in this manual are basic. The operating techniques assist with developing the skills and techniques required to operate the engine more efficiently and economically. Skill and techniques develop as the operator gains knowledge of the engine and the capabilities of the engine.

The operation section is a reference for operators. Photographs and illustrations guide the operator through procedures of inspecting, starting, operating, and stopping the engine. This section also includes a discussion of electronic diagnostic information.

### Maintenance

The maintenance section is a guide to engine care. The illustrated, step-by-step instructions are grouped by service hours and/or calendar time maintenance intervals. Items in the maintenance schedule are referenced to detailed instructions that follow.

Recommended service should be performed at the appropriate intervals as indicated in the Maintenance Interval Schedule. The actual operating environment of the engine also governs the Maintenance Interval Schedule. Therefore, under severe, dusty, wet, or freezing cold operating conditions, more frequent lubrication, and maintenance than is specified in the Maintenance Interval Schedule may be necessary.

The maintenance schedule items are organized for a preventive maintenance management program. If the preventive maintenance program is followed, a periodic tune-up is not required. The implementation of a preventive maintenance management program should minimize operating costs through cost avoidances resulting from reductions in unscheduled downtime and failures.

## **Maintenance Intervals**

Perform maintenance on items at multiples of the original requirement. Each level and/or individual items in each level should be shifted ahead or back depending upon your specific maintenance practices, operation, and application. Perkins recommends that the maintenance schedules be reproduced and displayed near the engine as a convenient reminder. Perkins also recommends that a maintenance record be maintained as part of the permanent record of the engine.

Your authorized Perkins dealer or your Perkins distributor can assist you in adjusting your maintenance schedule to meet the needs of your operating environment.

## **Overhaul**

Major engine overhaul details are not covered in the Operation and Maintenance Manual except for the interval and the maintenance items in that interval. Major repairs are best left to trained personnel or an authorized Perkins distributor or dealer. Your Perkins dealer or your Perkins distributor offers various options regarding overhaul programs. If you experience a major engine failure, there are also numerous after failure overhaul options available. Consult with your Perkins dealer or your Perkins distributor for information regarding these options.

## Safety Section

i04112132

### Safety Messages

There may be several specific warning signs on your engine. The exact location and a description of the warning signs are reviewed in this section. Please become familiar with all warning signs.

Ensure that all of the warning signs are legible. Clean the warning signs or replace the warning signs if the words cannot be read or if the illustrations are not visible. Use a cloth, water, and soap to clean the warning signs. Do not use solvents, gasoline, or other harsh chemicals. Solvents, gasoline, or harsh chemicals could loosen the adhesive that secures the warning signs. The warning signs that are loosened could drop off the engine.

Replace any warning sign that is damaged or missing. If a warning sign is attached to a part of the engine that is replaced, install a new warning sign on the replacement part. Your Perkins distributor can provide new warning signs.

### Universal Warning

#### **WARNING**

**Do not operate or work on this equipment unless you have read and understand the instructions and warnings in the Operation and Maintenance Manuals. Failure to follow the instructions or heed the warnings could result in serious injury or death.**

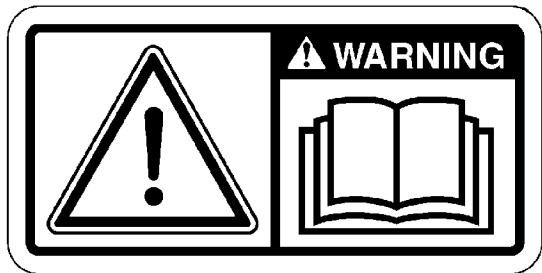

Illustration 1

g01154807

Typical example

The Universal Warning label (1) is located on the top of the engine, on the engine interface connector cover.

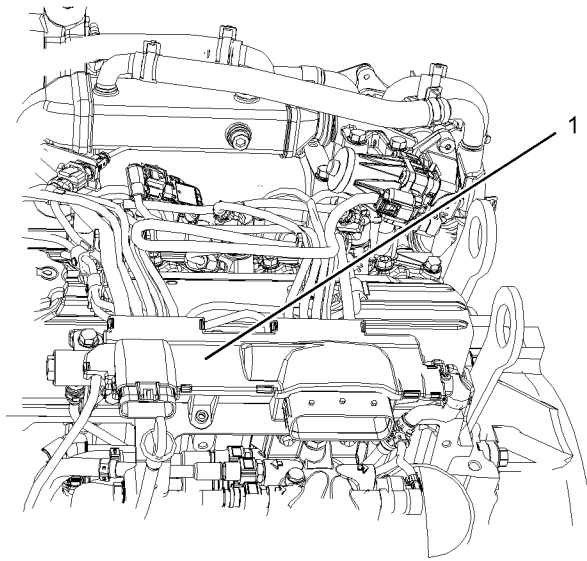

Illustration 2

g02582556

Typical example

i08315538

## General Hazard Information

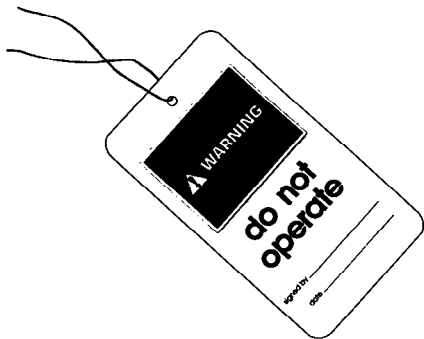

Illustration 3

g00104545

Attach a “Do Not Operate” warning tag or a similar warning tag to the start switch or to the controls before the engine is serviced or before the engine is repaired. Attach the warning tags to the engine and to each operator control station. When appropriate, disconnect the starting controls.

Do not allow unauthorized personnel on the engine, or around the engine when the engine is being serviced.

- Tampering with the engine installation or tampering with the OEM supplied wiring can be dangerous. Personal injury, death and/or engine damage could result.
- Vent the engine exhaust to the outside when the engine is operated in an enclosed area.
- If the engine is not running, do not release the secondary brake or the parking brake systems unless the vehicle is blocked or unless the vehicle is restrained.
- Wear a hard hat, protective glasses, and other protective equipment, as required.
- When work is performed around an engine that is operating, wear protective devices for ears to help prevent damage to hearing.
- Do not wear loose clothing or jewelry that can snag on controls or on other parts of the engine.
- Ensure that all protective guards and all covers are secured in place on the engine.
- Never put maintenance fluids into glass containers. Glass containers can break.
- Use all cleaning solutions with care.
- Report all necessary repairs.

Unless other instructions are provided, perform the maintenance under the following conditions:

- The engine is stopped. Ensure that the engine cannot be started.

Safety Section  
General Hazard Information

---

- The protective locks or the controls are in the applied position.
- Engage the secondary brakes or parking brakes.
- Block the vehicle or restrain the vehicle before maintenance or repairs are performed.
- Disconnect the batteries when maintenance is performed or when the electrical system is serviced. Disconnect the battery ground leads. Tape the leads to help prevent sparks.
- Disconnect the connector for the unit injector that is on the valve cover base. This action will help prevent personal injury from the high voltage to the unit injectors. Do not come in contact with the unit injector terminals while the engine is operating.
- Do not attempt any repairs or any adjustments to the engine while the engine is operating.
- Do not attempt any repairs that are not understood. Use the proper tools. Replace any equipment that is damaged or repair the equipment.
- For initial start-up of a new engine or for starting an engine that has been serviced, make provisions to stop the engine if an overspeed occurs. This action may be accomplished by shutting off the fuel supply and/or the air supply to the engine.
- Start the engine from the operators station (cab). Never short across the starting motor terminals or the batteries. This action could bypass the engine neutral start system and/or the electrical system could be damaged.

Engine exhaust contains products of combustion which may be harmful to your health. Always start the engine and operate the engine in a well ventilated area. If the engine is in an enclosed area, vent the engine exhaust to the outside.

Cautiously remove the following parts. To help prevent spraying or splashing of pressurized fluids, hold a rag over the part that is being removed.

- Filler caps
- Grease fittings
- Pressure taps
- Breathers
- Drain plugs

Use caution when cover plates are removed. Gradually loosen, but do not remove the last two bolts or nuts that are at opposite ends of the cover plate or the device. Before removing the last two bolts or nuts, pry the cover loose to relieve any spring pressure or other pressure.

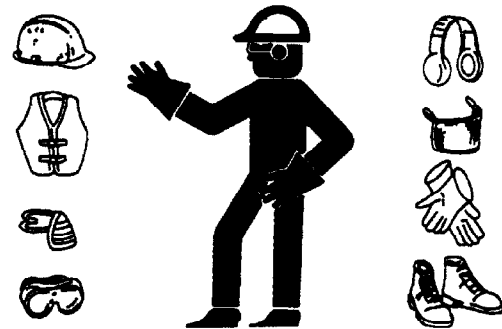

Illustration 4

g00702020

- Wear a hard hat, protective glasses, and other protective equipment, as required.
- When work is performed around an engine that is operating, wear protective devices for ears to help prevent damage to hearing.
- Do not wear loose clothing or jewelry that can snag on controls or on other parts of the engine.
- Ensure that all protective guards and all covers are secured in place on the engine.
- Never put maintenance fluids into glass containers. Glass containers can break.
- Use all cleaning solutions with care.
- Report all necessary repairs.

**Unless other instructions are provided, perform the maintenance under the following conditions:**

- The engine is stopped. Ensure that the engine cannot be started.
- Disconnect the batteries when maintenance is performed or when the electrical system is serviced. Disconnect the battery ground leads. Tape the leads to help prevent sparks.
- Do not attempt any repairs that are not understood. Use the proper tools. Replace any equipment that is damaged or repair the equipment.



## Pressurized Air and Water

Pressurized air and/or water can cause debris and/or hot water to be blown out and could result in personal injury.

When pressurized air and/or pressurized water is used for cleaning, wear protective clothing, protective shoes, and eye protection. Eye protection includes goggles or a protective face shield.

The maximum air pressure for cleaning purposes must be below 205 kPa (30 psi). The maximum water pressure for cleaning purposes must be below 275 kPa (40 psi).

## Fluid Penetration

Pressure can be trapped in the hydraulic circuit long after the engine has been stopped. The pressure can cause hydraulic fluid or items such as pipe plugs to escape rapidly if the pressure is not relieved correctly.

Do not remove any hydraulic components or parts until pressure has been relieved or personal injury may occur. Do not disassemble any hydraulic components or parts until pressure has been relieved or personal injury may occur. Refer to the OEM information for any procedures that are required to relieve the hydraulic pressure.

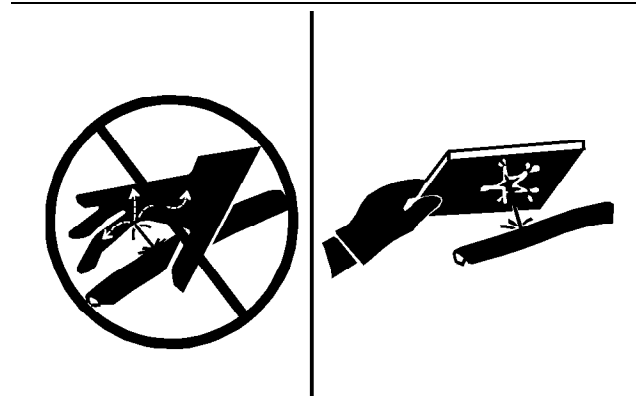

Illustration 5

g00687600

Always use a board or cardboard when you check for a leak. Leaking fluid that is under pressure can penetrate body tissue. Fluid penetration can cause serious injury and possible death. A pin hole leak can cause severe injury. If fluid is injected into your skin, you must get treatment immediately. Seek treatment from a doctor that is familiar with this type of injury.

## Containing Fluid Spillage

### NOTICE

Care must be taken to ensure that fluids are contained during performance of inspection, maintenance, testing, adjusting, and repair of the product. Be prepared to collect the fluid with suitable containers before opening any compartment or disassembling any component containing fluids.

Dispose of all fluids according to local regulations and mandates.

## Static Electricity Hazard when Fueling with Ultra-low Sulfur Diesel Fuel

The removal of sulfur and other compounds in ultra-low sulfur diesel fuel (ULSD fuel) decreases the conductivity of ULSD and increases the ability of ULSD to store static charge. Refineries may have treated the fuel with a static dissipating additive. Many factors can reduce the effectiveness of the additive over time. Static charges can build up in ULSD fuel while the fuel is flowing through fuel delivery systems. Static electricity discharge when combustible vapors are present could result in a fire or explosion. Ensure that the entire system used to refuel your machine (fuel supply tank, transfer pump, transfer hose, nozzle, and others) is properly grounded and bonded. Consult with your fuel or fuel system supplier to ensure that the delivery system complies with fueling standards for proper grounding and bonding.

**⚠ WARNING**

**Avoid static electricity risk when fueling. Ultra-low sulfur diesel fuel (ULSD fuel) poses a greater static ignition hazard than earlier diesel formulations with a higher sulfur contents. Avoid death or serious injury from fire or explosion. Consult with your fuel or fuel system supplier to ensure the delivery system is in compliance with fueling standards for proper grounding and bonding practices.**

## Inhalation



Illustration 6

g00702022

## Exhaust

Use caution. Exhaust fumes can be hazardous to health. If you operate the equipment in an enclosed area, adequate ventilation is necessary.

## Hexavalent Chromium

Perkins equipment and replacement parts comply with applicable regulations and requirements where originally sold. Perkins recommends the use of only genuine Perkins replacement parts.

Hexavalent chromium has occasionally been detected on exhaust and heat shield systems on Perkins engines. Although laboratory testing is the only accurate way to know if hexavalent chromium is, in fact, present, the presence of a yellow deposit in areas of high heat (for example, exhaust system components or exhaust insulation) may be an indication of the presence of hexavalent chromium.

Use caution if you suspect the presence of hexavalent chromium. Avoid skin contact when handling items that you suspect may contain hexavalent chromium, and avoid inhalation of any dust in the suspect area. Inhalation of, or skin contact with, hexavalent chromium dust may be hazardous to your health.

If such yellow deposits are found on the engine, engine component parts, or associated equipment or packages, Perkins recommends following local health and safety regulations and guidelines, utilizing good hygiene, and adhering to safe work practices when handling the equipment or parts. Perkins also recommends the following:

- Wear appropriate Personal Protective Equipment (PPE)
- Wash your hands and face with soap and water prior to eating, drinking, or smoking, and also during rest room breaks, to prevent ingestion of any yellow powder
- Never use compressed air for cleaning areas suspected of containing hexavalent chromium
- Avoid brushing, grinding, or cutting materials suspected of containing hexavalent chromium
- Obey environmental regulations for the disposal of all materials that may contain or have come into contact with hexavalent chromium
- Stay away from areas that might have hexavalent chromium particles in the air.

## Asbestos Information

Perkins equipment and replacement parts that are shipped from Perkins engine company limited are asbestos free. Perkins recommends the use of only genuine Perkins replacement parts. Use the following guidelines when you handle any replacement parts that contain asbestos or when you handle asbestos debris.

Use caution. Avoid inhaling dust that might be generated when you handle components that contain asbestos fibers. Inhaling this dust can be hazardous to your health. The components that may contain asbestos fibers are brake pads, brake bands, lining material, clutch plates, and some gaskets. The asbestos that is used in these components is usually bound in a resin or sealed in some way. Normal handling is not hazardous unless airborne dust that contains asbestos is generated.

If dust that may contain asbestos is present, there are several guidelines that should be followed:

- Never use compressed air for cleaning.
- Avoid brushing materials that contain asbestos.
- Avoid grinding materials that contain asbestos.
- Use a wet method to clean up asbestos materials.
- A vacuum cleaner that is equipped with a high efficiency particulate air filter (HEPA) can also be used.

- Use exhaust ventilation on permanent machining jobs.
- Wear an approved respirator if there is no other way to control the dust.
- Comply with applicable rules and regulations for the work place. In the United States, use Occupational Safety and Health Administration (OSHA) requirements. These OSHA requirements can be found in "29 CFR 1910.1001".
- Obey environmental regulations for the disposal of asbestos.
- Stay away from areas that might have asbestos particles in the air.

## Dispose of Waste Properly

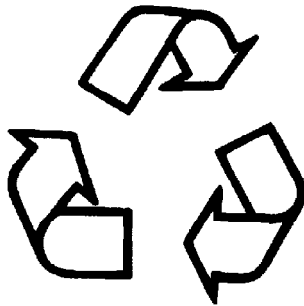

Illustration 7

g00706404

Improperly disposing of waste can threaten the environment. Potentially harmful fluids should be disposed of according to local regulations.

Always use leakproof containers when you drain fluids. Do not pour waste onto the ground, down a drain, or into any source of water.

i06702818

## Burn Prevention

Do not touch any part of an operating engine system. The engine, the exhaust, and the engine aftertreatment system can reach temperatures as high as 650 °C (1202 °F) under normal operating conditions.

At idle engine speed and/or zero vehicle speed, an operator can request manual regeneration. Under this condition, the exhaust gas temperature can reach 650 °C (1202 °F). Otherwise automatic regeneration can produce exhaust gas temperatures as high as 650 °C (1202 °F).

Allow the engine system to cool before any maintenance is performed. Relieve all pressure in the following systems, hydraulic system, lubrication system, fuel system, and the cooling system before related items are disconnected.

### **WARNING**

**Contact with high pressure fuel may cause fluid penetration and burn hazards. High pressure fuel spray may cause a fire hazard. Failure to follow these inspection, maintenance and service instructions may cause personal injury or death.**

After the engine has stopped, you must wait for 10 minutes to allow the fuel pressure to be purged from the high-pressure fuel lines before any service or repair is performed on the engine fuel lines.

## Induction System

### **WARNING**

**Sulfuric Acid Burn Hazard may cause serious personal injury or death.**

The exhaust gas cooler may contain a small amount of sulfuric acid. The use of fuel with sulfur levels greater than 15 ppm may increase the amount of sulfuric acid formed. The sulfuric acid may spill from the cooler during service of the engine. The sulfuric acid will burn the eyes, skin and clothing on contact. Always wear the appropriate personal protective equipment (PPE) that is noted on a material safety data sheet (MSDS) for sulfuric acid. Always follow the directions for first aid that are noted on a material safety data sheet (MSDS) for sulfuric acid.

## Coolant

When the engine is at operating temperature, the engine coolant is hot. The coolant is also under pressure. The radiator and all lines to the heaters or to the engine contain hot coolant.

Any contact with hot coolant or with steam can cause severe burns. Allow cooling system components to cool before the cooling system is drained.

Check the coolant level after the engine has stopped and the engine has been allowed to cool.

Ensure that the filler cap is cool before removing the filler cap. The filler cap must be cool enough to touch with a bare hand. Remove the filler cap slowly to relieve pressure.

Cooling system conditioner contains alkali. Alkali can cause personal injury. Do not allow alkali to contact the skin, the eyes, or the mouth.

i04303237

## Oils

Skin may be irritated following repeated or prolonged exposure to mineral and synthetic base oils. Refer to your suppliers Material Safety Data Sheets for detailed information. Hot oil and lubricating components can cause personal injury. Do not allow hot oil to contact the skin. Appropriate personal protective equipment should be used.

## Diesel Fuel

Diesel may be irritating to the eyes, respiratory system, and skin. Prolonged exposure to diesel may cause various skin conditions. Appropriate personal protective equipment should be used. Refer to supplier Material safety Data sheets for detailed information.

## Aftertreatment System

Allow the aftertreatment to cool down before any maintenance or repair is performed.

## Batteries

Electrolyte is an acid. Electrolyte can cause personal injury. Do not allow electrolyte to contact the skin or the eyes. Always wear protective glasses for servicing batteries. Wash hands after touching the batteries and connectors. Use of gloves is recommended.

# Fire Prevention and Explosion Prevention

---



Illustration 8

g00704000

All fuels, most lubricants, and some coolant mixtures are flammable.

Flammable fluids that are leaking or spilled onto hot surfaces or onto electrical components can cause a fire. Fire may cause personal injury and property damage.

After the emergency stop button is operated, ensure that you allow 15 minutes, before the engine covers are removed.

Determine whether the engine will be operated in an environment that allows combustible gases to be drawn into the air inlet system. These gases could cause the engine to overspeed. Personal injury, property damage, or engine damage could result.

If the application involves the presence of combustible gases, consult your Perkins dealer and/or your Perkins distributor for additional information about suitable protection devices.

Remove all flammable combustible materials or conductive materials such as fuel, oil, and debris from the engine. Do not allow any flammable combustible materials or conductive materials to accumulate on the engine.

Store fuels and lubricants in correctly marked containers away from unauthorized persons. Store oily rags and any flammable materials in protective containers. Do not smoke in areas that are used for storing flammable materials.

Do not expose the engine to any flame.

Exhaust shields (if equipped) protect hot exhaust components from oil or fuel spray in a line, a tube, or a seal failure. Exhaust shields must be installed correctly.

Do not weld on lines or tanks that contain flammable fluids. Do not flame cut lines or tanks that contain flammable fluid. Clean any such lines or tanks thoroughly with a nonflammable solvent prior to welding or flame cutting.

Wiring must be kept in good condition. All electrical wires must be correctly routed and securely attached. Check all electrical wires daily. Repair any wires that are loose or frayed before you operate the engine. Clean all electrical connections and tighten all electrical connections.

Eliminate all wiring that is unattached or unnecessary. Do not use any wires or cables that are smaller than the recommended gauge. Do not bypass any fuses and/or circuit breakers.

Arcing or sparking could cause a fire. Secure connections, recommended wiring, and correctly maintained battery cables will help to prevent arcing or sparking.

**⚠ WARNING**

**Contact with high pressure fuel may cause fluid penetration and burn hazards. High pressure fuel spray may cause a fire hazard. Failure to follow these inspection, maintenance and service instructions may cause personal injury or death.**

After the engine has stopped, you must wait for 10 minutes in order to allow the fuel pressure to be purged from the high-pressure fuel lines before any service or repair is performed on the engine fuel lines.

Ensure that the engine is stopped. Inspect all lines and hoses for wear or for deterioration. The hoses must be correctly routed. The lines and hoses must have adequate support and secure clamps.

Ensure that Oil filters and fuel filters are correctly installed. The filter housings must be tightened to the correct torque. Refer to the Disassembly and Assembly manual for more information.



Illustration 9

g00704059

Use caution when you are refueling an engine. Do not smoke while you are refueling an engine. Do not refuel an engine near open flames or sparks. Always stop the engine before refueling.



Illustration 10

g00704135

Gases from a battery can explode. Keep any open flames or sparks away from the top of a battery. Do not smoke in battery charging areas.

Never check the battery charge by placing a metal object across the terminal posts. Use a voltmeter or a hydrometer.

Incorrect jumper cable connections can cause an explosion that can result in injury. Refer to the Operation Section of this manual for specific instructions.

Do not charge a frozen battery. Charging a frozen battery may cause an explosion.

The batteries must be kept clean. The covers (if equipped) must be kept on the cells. Use the recommended cables, connections, and battery box covers when the engine is operated.

## Fire Extinguisher

Make sure that a fire extinguisher is available. Be familiar with the operation of the fire extinguisher. Inspect the fire extinguisher and service the fire extinguisher regularly. Obey the recommendations on the instruction plate.

## Lines, Tubes, and Hoses

Do not bend high-pressure lines. Do not strike high-pressure lines. Do not install any lines that are damaged.

Leaks can cause fires. Consult your Perkins dealer or your Perkins distributor for replacement parts.

Replace the parts if any of the following conditions are present:

- High-pressure fuel line or lines are removed.
- End fittings are damaged or leaking.
- Outer coverings are chafed or cut.
- Wires are exposed.
- Outer coverings are ballooning.
- Flexible parts of the hoses are kinked.
- Outer covers have embedded armoring.
- End fittings are displaced.

Make sure that all clamps, guards, and heat shields are installed correctly. During engine operation, this check will help to prevent vibration, rubbing against other parts, and excessive heat.

## Regeneration

The exhaust gas temperature during regeneration will be elevated. Follow proper fire prevention instructions and use the disable switch function when appropriate.

i02143194

## Crushing Prevention and Cutting Prevention

Support the component correctly when work beneath the component is performed.

Unless other maintenance instructions are provided, never attempt adjustments while the engine is running.

Stay clear of all rotating parts and of all moving parts. Leave the guards in place until maintenance is performed. After the maintenance is performed, reinstall the guards.

Keep objects away from moving fan blades. The fan blades will throw objects or cut objects.

When objects are struck, wear protective glasses in order to avoid injury to the eyes.

Chips or other debris may fly off objects when objects are struck. Before objects are struck, ensure that no one will be injured by flying debris.

i05768982

## Mounting and Dismounting

Do not climb on the engine or the engine aftertreatment system. The engine and aftertreatment system have not been designed with mounting or dismounting locations.

Refer to the OEM for the location of foot and hand holds for your specific application.

i04112191

## High Pressure Fuel Lines

### WARNING

Contact with high pressure fuel may cause fluid penetration and burn hazards. High pressure fuel spray may cause a fire hazard. Failure to follow these inspection, maintenance and service instructions may cause personal injury or death.

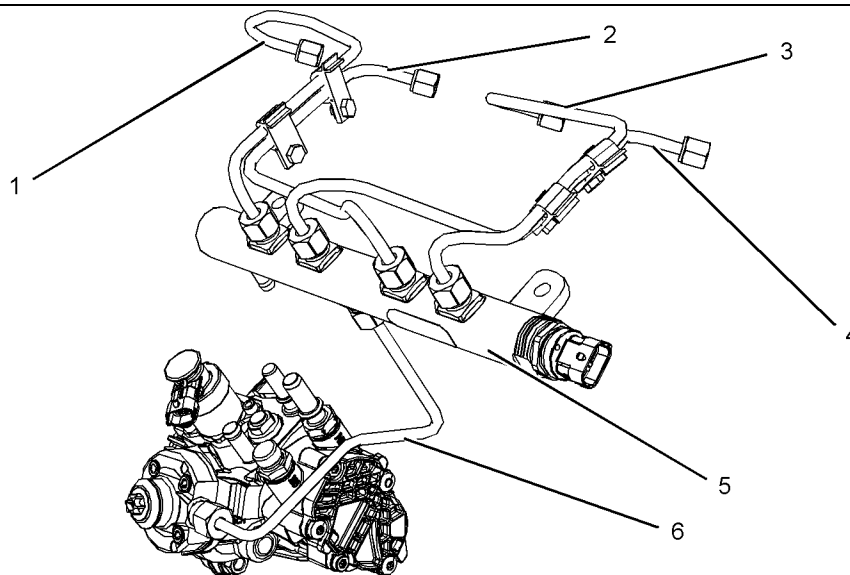

Illustration 11

g02315653

(1) High-pressure line  
(2) High-pressure line

(3) High-pressure line  
(4) High-pressure line

(5) High-pressure fuel manifold (rail)  
(6) Fuel transfer line that is high pressure

The high-pressure fuel lines are the fuel lines that are between the high-pressure fuel pump and the high-pressure fuel manifold and the fuel lines that are between the fuel manifold and cylinder head. These fuel lines are different from fuel lines on other fuel systems.

These differences are because of the following items:

- The high-pressure fuel lines are constantly charged with high pressure.
- The internal pressures of the high-pressure system fuel lines are higher than other types of fuel system.
- The high-pressure fuel lines are formed to shape and then strengthened by a special process.

Do not step on the high-pressure fuel lines. Do not deflect the high-pressure fuel lines. Do not bend or strike the high-pressure fuel lines. Deformation or damage of the high-pressure fuel lines may cause a point of weakness and potential failure.

Do not check the high-pressure fuel lines with the engine or the starting motor in operation. After the engine has stopped wait for 10 minutes in order to allow the fuel pressure to be purged from the high-pressure fuel lines before any service or repair is performed.

Do not loosen the high-pressure fuel lines in order to remove air from the fuel system. This procedure is not required.

Visually inspect the high-pressure fuel lines before the engine is started. This inspection should be each day.

If you inspect the engine in operation, always use the proper inspection procedure in order to avoid a fluid penetration hazard. Refer to Operation and Maintenance Manual, "General hazard Information".

- Inspect the high-pressure fuel lines for damage, deformation, a nick, a cut, a crease, or a dent.

## Safety Section Before Starting Engine

---

- Do not operate the engine with a fuel leak. If there is a leak, do not tighten the connection in order to stop the leak. The connection must only be tightened to the recommended torque. Refer to Disassembly and Assembly, “Fuel injection lines - Remove and Fuel injection lines - Install”.
- If the high-pressure fuel lines are torqued correctly, and the high-pressure fuel lines are leaking the high-pressure fuel lines must be replaced.
- Ensure that all clips on the high-pressure fuel lines are in place. Do not operate the engine with clips that are damaged, missing, or loose.
- Do not attach any other item to the high-pressure fuel lines.
- Loosened high-pressure fuel lines must be replaced. Also removed high-pressure fuel lines must be replaced. Refer to Disassembly and Assembly, “Fuel Injection Lines - Install”.

i05874054

## Before Starting Engine

---

### NOTICE

For initial start-up of a new or rebuilt engine, and for start-up of an engine that has been serviced, make provision to shut the engine off should an overspeed occur. This may be accomplished by shutting off the air and/or fuel supply to the engine.

---

### WARNING

**Engine exhaust contains products of combustion which may be harmful to your health. Always start and operate the engine in a well ventilated area and, if in an enclosed area, vent the exhaust to the outside.**

---

Inspect the engine for potential hazards.

Do not start the engine or move any of the controls if there is a “DO NOT OPERATE” warning tag or similar warning tag attached to the start switch or to the controls.

Before starting the engine, ensure that no one is on, underneath, or close to the engine. Ensure that the area is free of personnel.

If equipped, ensure that the lighting system for the engine is suitable for the conditions. Ensure that all lights work properly, if equipped.

All protective guards and all protective covers must be installed if the engine must be started in order to perform service procedures. To help prevent an accident that is caused by parts in rotation, work around the parts carefully.

Do not bypass the automatic shutoff circuits. Do not disable the automatic shutoff circuits. The circuits are provided in order to help prevent personal injury. The circuits are also provided in order to help prevent engine damage.

See the Service Manual for repairs and for adjustments.

i04478934

## Engine Starting

### WARNING

**Do not use aerosol types of starting aids such as ether. Such use could result in an explosion and personal injury.**

---

If a warning tag is attached to the engine start switch, or to the controls DO NOT start the engine or move the controls. Consult with the person that attached the warning tag before the engine is started.

All protective guards and all protective covers must be installed if the engine must be started in order to perform service procedures. To help prevent an accident that is caused by parts in rotation, work around the parts carefully.

Start the engine from the operators compartment or from the engine start switch.

Always start the engine according to the procedure that is described in the Operation and Maintenance Manual, “Engine Starting” topic in the Operation Section. Knowing that the correct procedure will help to prevent major damage to the engine components. Knowing that the procedure will also help to prevent personal injury.

To ensure that the jacket water heater (if equipped) and/or the lube oil heater (if equipped) is working correctly, check the water temperature gauge. Also, check the oil temperature gauge during the heater operation.

Engine exhaust contains products of combustion which can be harmful to your health. Always start the engine and operate the engine in a well ventilated area. If the engine is started in an enclosed area, vent the engine exhaust to the outside.

**Note:** These engines are equipped with a glow plug starting aid in each cylinder that heats the intake air in order to improve starting.



i02234873

## Engine Stopping

Stop the engine according to the procedure in the Operation and Maintenance Manual, "Engine Stopping (Operation Section)" in order to avoid overheating of the engine and accelerated wear of the engine components.

Use the Emergency Stop Button (if equipped) **ONLY** in an emergency situation. Do not use the Emergency Stop Button for normal engine stopping. After an emergency stop, **DO NOT** start the engine until the problem that caused the emergency stop has been corrected.

Stop the engine if an overspeed condition occurs during the initial start-up of a new engine or an engine that has been overhauled.

To stop an electronically controlled engine, cut the power to the engine and/or shutting off the air supply to the engine.

i04112409

## Electrical System

Never disconnect any charging unit circuit or battery circuit cable from the battery when the charging unit is operating. A spark can cause the combustible gases that are produced by some batteries to ignite.

To help prevent sparks from igniting combustible gases that are produced by some batteries, the negative "-" cable should be connected last from the external power source to the negative "-" terminal of the starting motor. If the starting motor is not equipped with a negative "-" terminal, connect the cable to the engine block.

Check the electrical wires daily for wires that are loose or frayed. Tighten all loose electrical connections before the engine is started. Repair all frayed electrical wires before the engine is started. See the Operation and Maintenance Manual for specific starting instructions.

## Grounding Practices

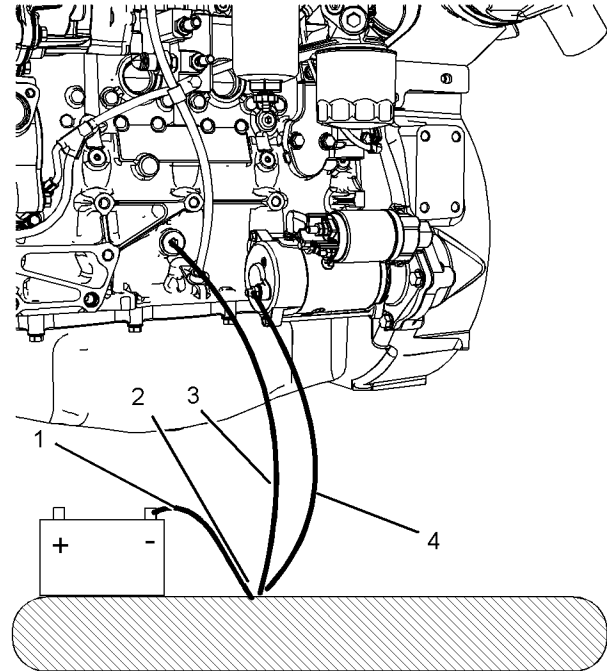

Illustration 12

g02315896

### Typical example

- (1) Ground to battery
- (2) Primary position for grounding
- (3) Ground to engine block
- (4) Ground to starting motor

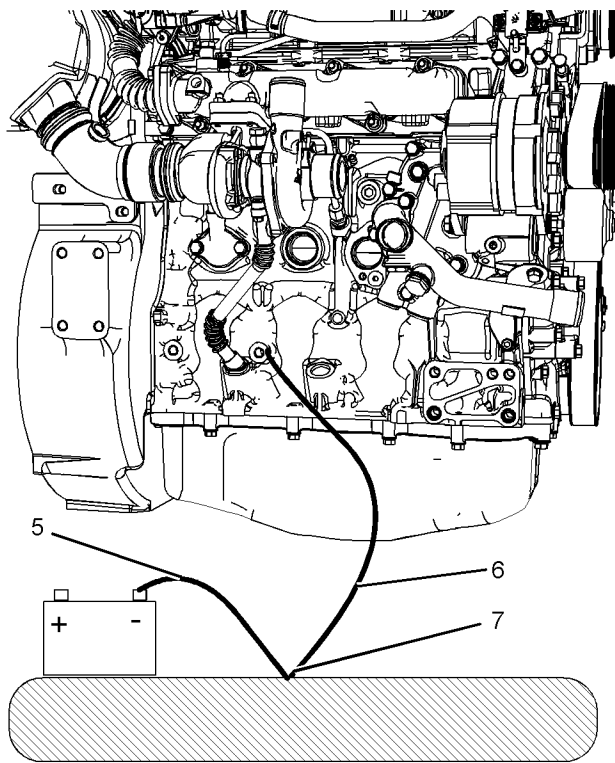

Illustration 13

g02315900

**Typical example**

- (5) Ground to battery
- (6) Ground to engine block
- (7) Primary position for grounding

Correct grounding for the engine electrical system is necessary for optimum engine performance and reliability. Incorrect grounding will result in uncontrolled electrical circuit paths and in unreliable electrical circuit paths.

Uncontrolled electrical circuit paths can result in damage to engine components.

Engines that are installed without engine-to-frame ground straps can be damaged by electrical discharge.

To ensure the engine and the engine electrical systems function correctly, an engine-to-frame ground strap with a direct path to the battery must be used. This path may be provided by way of a direct engine ground to the frame.

The connections for the grounds should be tight and free of corrosion. The engine alternator must be grounded to the negative “-” battery terminal with a wire adequate to handle the full charging current of the alternator.

The power supply connections and the ground connections for the engine electronics should always be from the isolator to the battery.

i04346349

**Engine Electronics****⚠ WARNING**

**Tampering with the electronic system installation or the OEM wiring installation can be dangerous and could result in personal injury or death and/or engine damage.**

**⚠ WARNING**

**Electrical Shock Hazard. The electronic unit injectors use DC voltage. The ECM sends this voltage to the electronic unit injectors. Do not come in contact with the harness connector for the electronic unit injectors while the engine is operating. Failure to follow this instruction could result in personal injury or death.**

This engine has a comprehensive, programmable Engine Monitoring System. The Electronic Control Module (ECM) has the ability to monitor the engine operating conditions. If any of the engine parameters extend outside an allowable range, the ECM will initiate an immediate action.

The following actions are available for engine monitoring control:

- Warning
- Derate
- Shutdown

The following monitored engine operating conditions and components have the ability to limit engine speed and/or the engine power:

- Engine Coolant Temperature
- Engine Oil Pressure
- Engine Speed
- Intake Manifold Air Temperature
- Engine Intake Throttle Valve Fault
- Wastegate Regulator
- Supply Voltage to Sensors
- Fuel Pressure in Manifold (Rail)
- NOx Reduction System

- Engine Aftertreatment System

The Engine Monitoring package can vary for different engine models and different engine applications. However, the monitoring system and the engine monitoring control will be similar for all engines.

# Product Information Section

## General Information

i06703805

## Model View Illustrations

The following model views show typical features of the engine. Due to individual applications, your engine may appear different from the illustrations.

## Engine and Aftertreatment

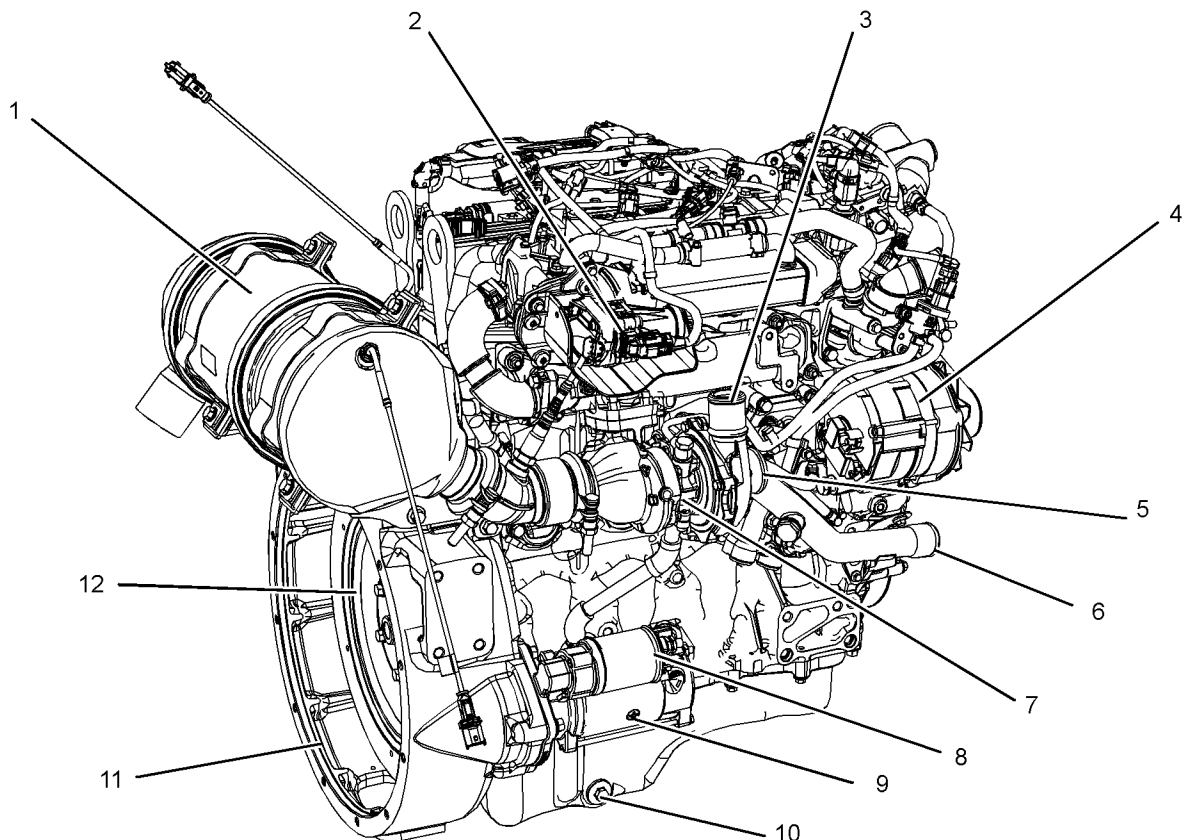

Illustration 14

g03367500

### Typical example

- |   |                                 |                       |
|---|---------------------------------|-----------------------|
| (1) Engine aftertreatment system            | (5) Air intake from air filter  | (9) Starting motor    |
| (2) NOx control valve                       | (6) Coolant intake connection   | (10) Oil drain plug   |
| (3) Air outlet connection from turbocharger | (7) Turbocharger                | (11) Flywheel housing |
| (4) Alternator                              | (8) Solenoid for starting motor | (12) Flywheel         |

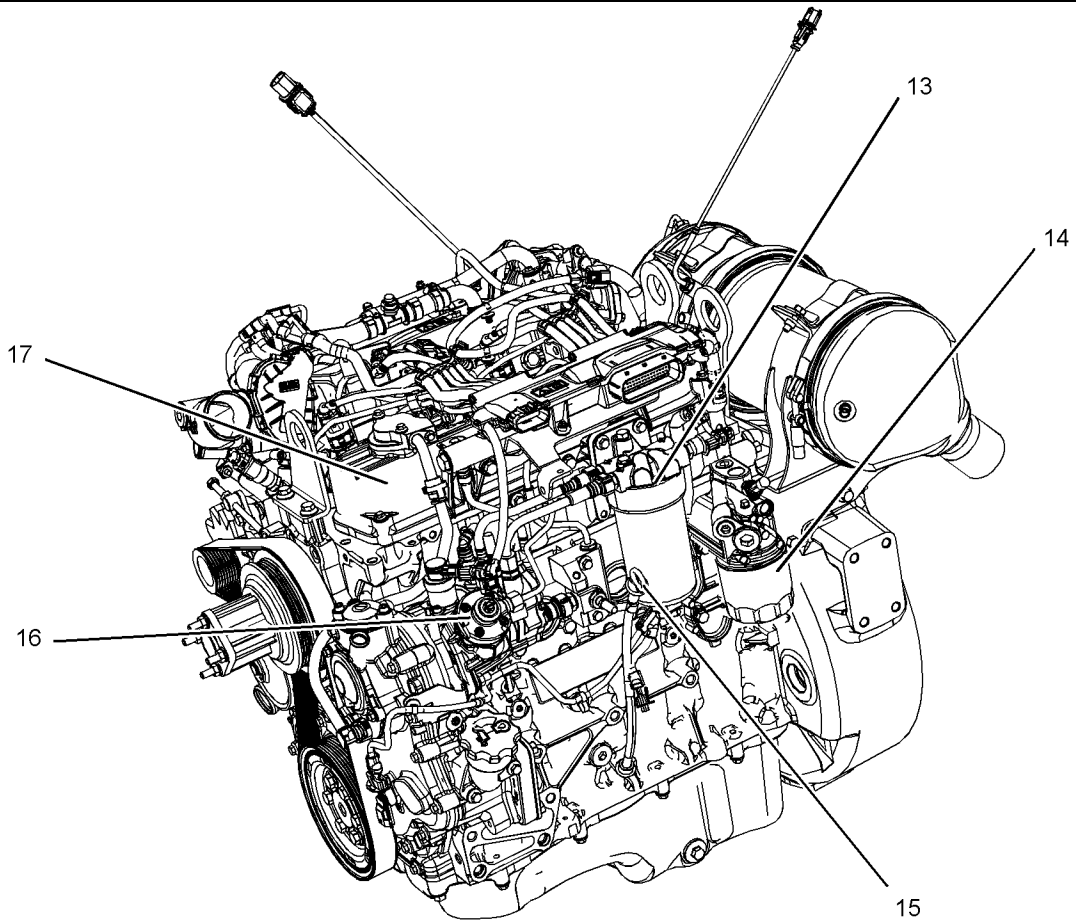

Illustration 15

g03367502

Typical example

(13) Secondary fuel filter  
(14) Oil filter

(15) Oil level gauge (Dipstick)  
(16) High-pressure fuel pump

(17) Valve mechanism cover

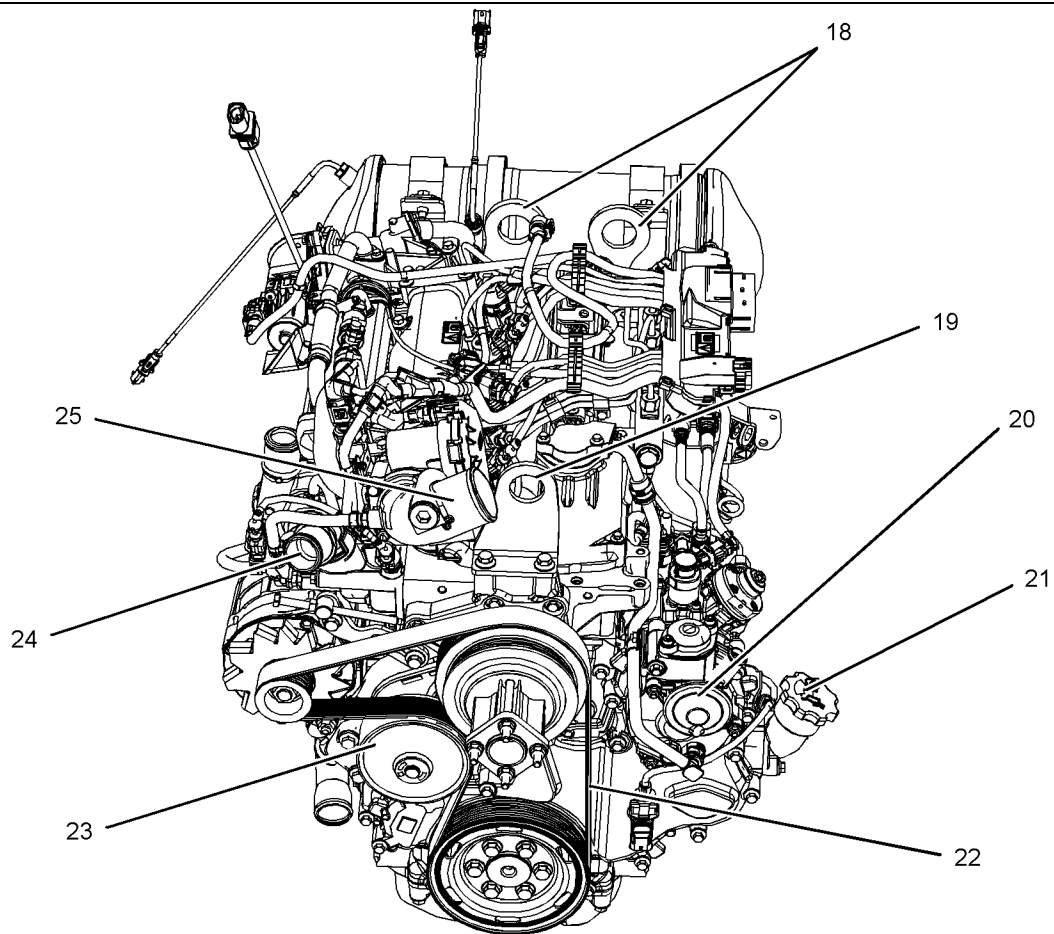

Illustration 16

g03367547

(18) Rear lifting eyes  
 (19) Front lifting eye  
 (20) Crankcase breather

(21) Oil filler cap  
 (22) Belt  
 (23) Coolant pump

(24) Coolant outlet connection  
 (25) Air inlet connection

The oil filler cap (21) can also be located on the valve mechanism cover.

Off Engine Parts

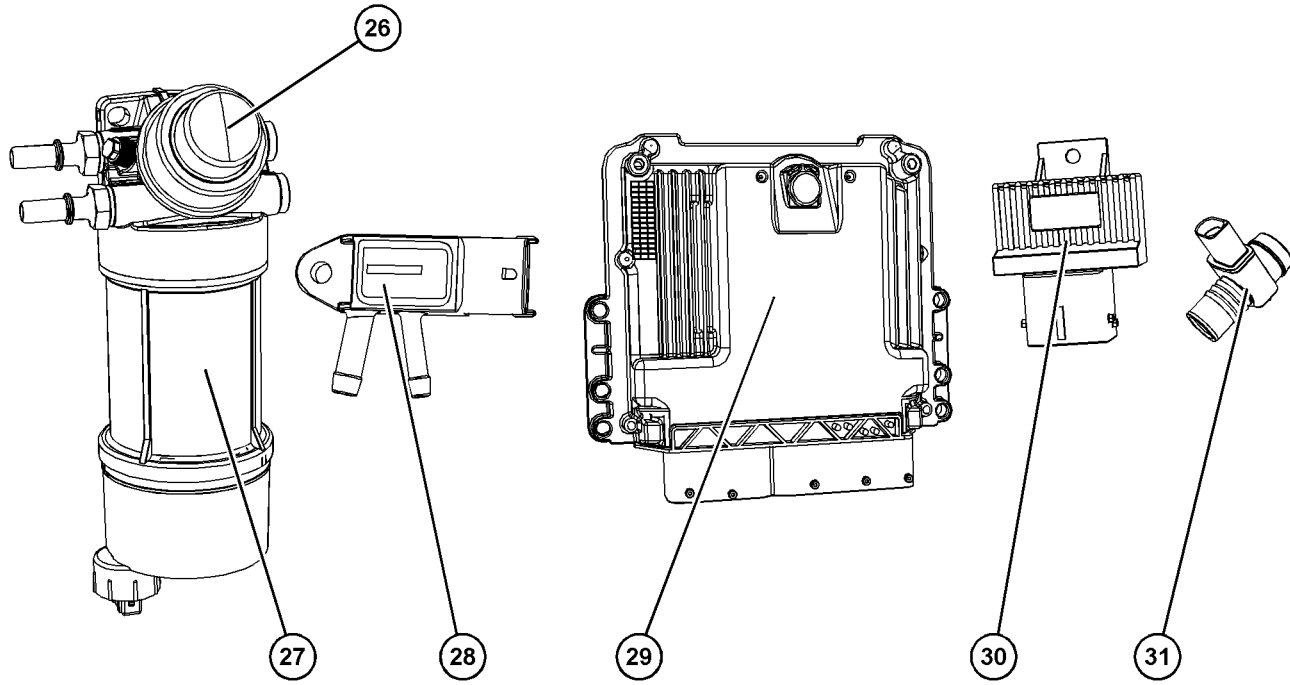

Illustration 17

g06082900

(26) Fuel priming pump  
(27) Primary fuel filter

(28) Differential pressure sensor  
(29) Electronic control module

(30) Relay for glow plugs  
(31) Breather heater

## Engine View with Wall Flow Diesel Particulate Filter

---

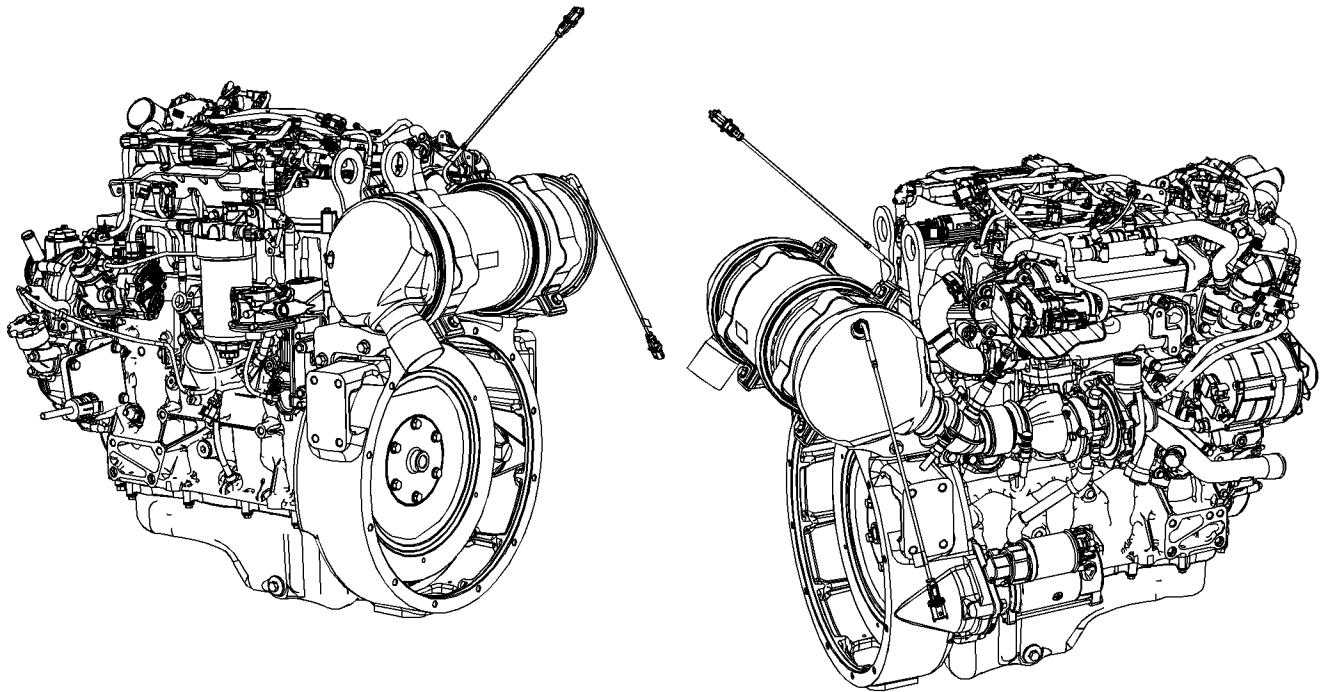

---

Illustration 18

Typical example

g03367096

The wall flow Diesel Particulate Filter (DPF) will require a service, refer to this Operation and Maintenance Manual, "Maintenance Interval Schedule" for the service period.



## Top Mounted Aftertreatment

---

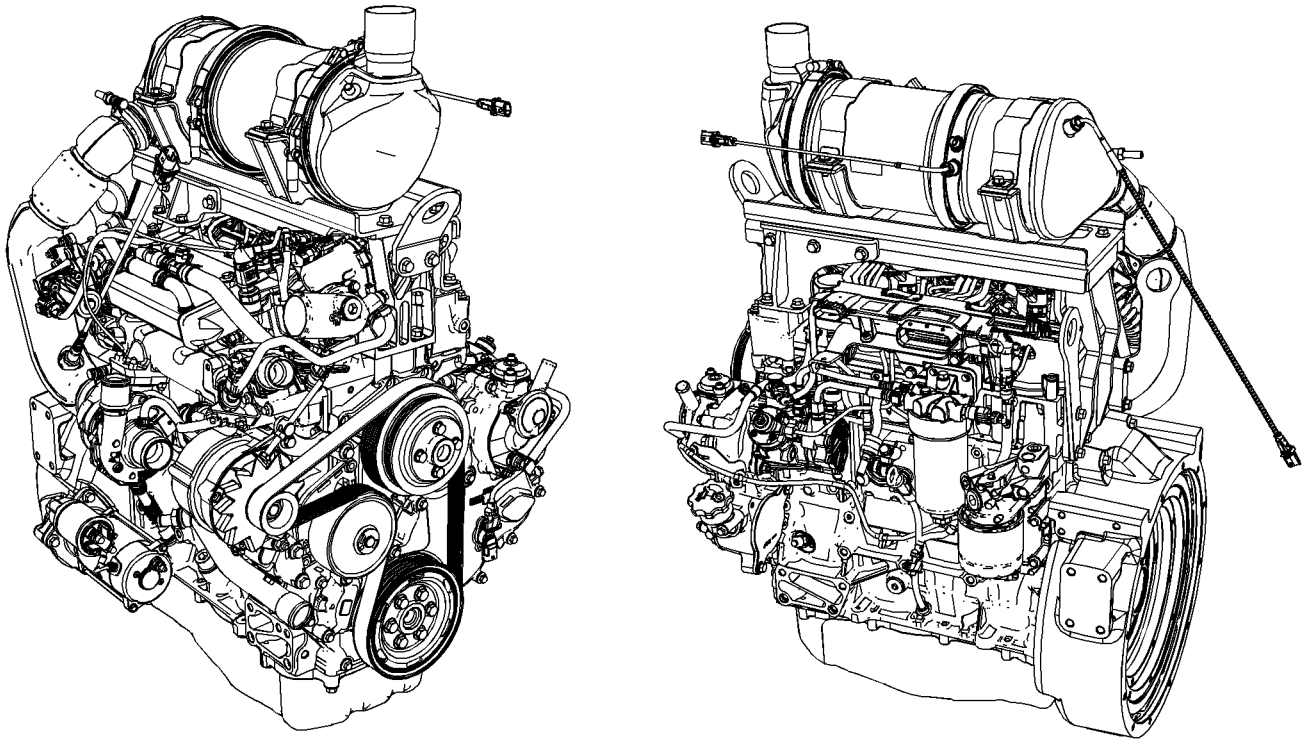

---

Illustration 19  
Typical example

g06082892

The wall flow Diesel Particulate Filter (DPF) will require a service, refer to this Operation and Maintenance Manual, "Maintenance Interval Schedule" for the service period.

## Engine View with Through Flow Diesel Particulate Filter

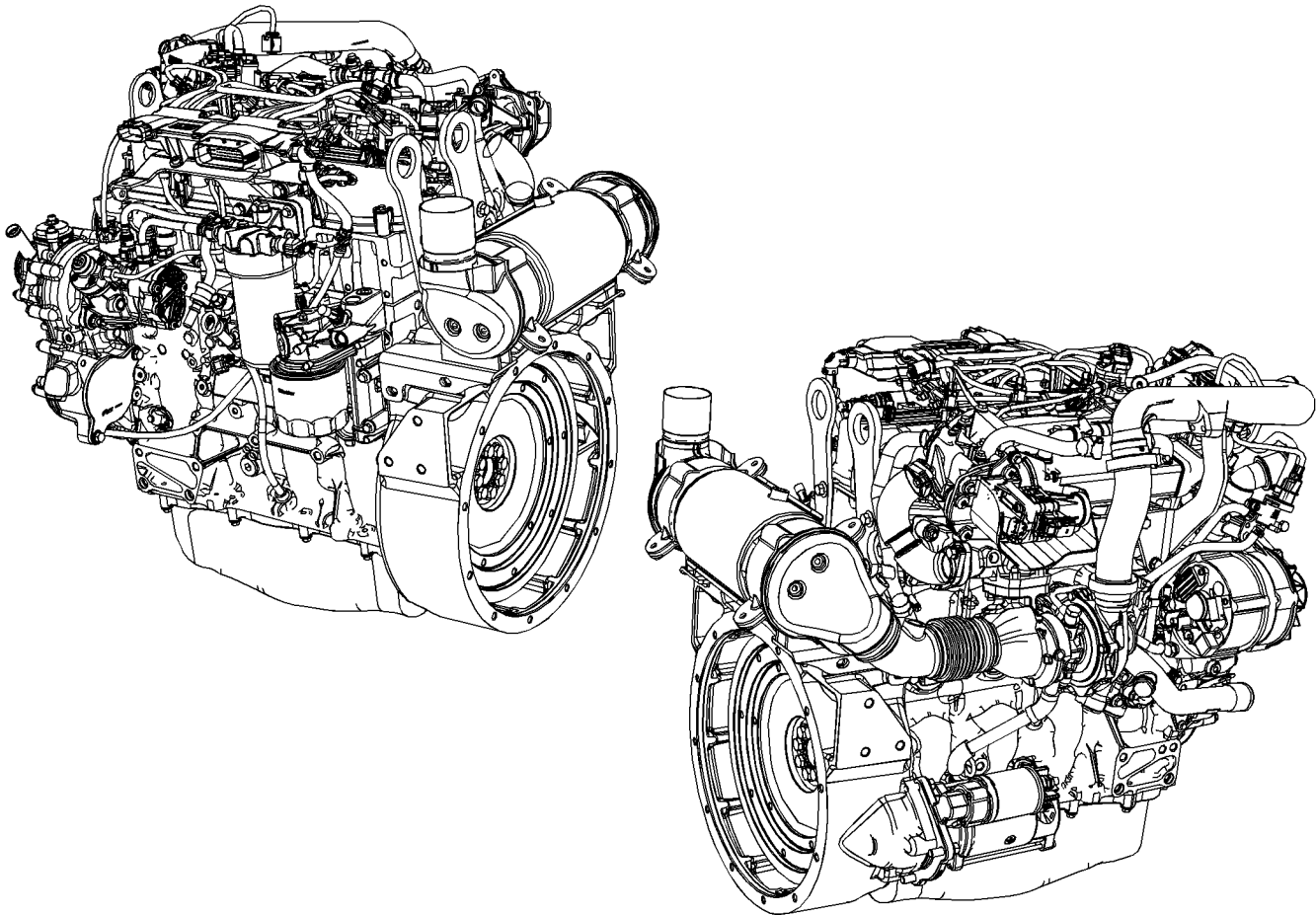

Illustration 20

g03367094

Typical example

The through-flow type of DPF will not require a service interval.

i06703970

## Product Description

The Perkins 854F-E34T, 854F-E34TA, and the 854E-E34TA industrial engines has the following characteristics.

- In-line 4 cylinder
- Two valves in each cylinder

- Four stroke cycle
- Turbocharged
- Turbocharged charge cooled
- Wall Flow Diesel Particulate Filter or Through-Flow Diesel Particulate Filter

## Engine Specifications

**Note:** The front end of the engine is opposite the flywheel end of the engine. The left and the right sides of the engine are determined from the flywheel end. The number 1 cylinder is the front cylinder.

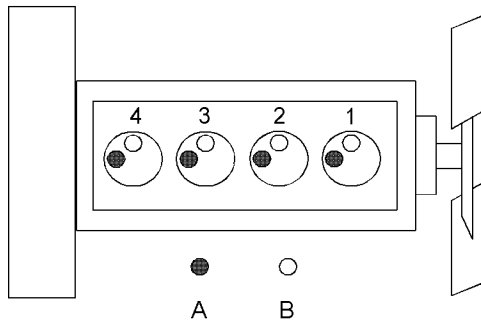

Illustration 21

g02317934

### Cylinder and valve location

- (A) Exhaust valves  
(B) Inlet valves

Table 1

854F-E34T 854F-E34TA and 854E-E34TA Engine Specifications	
Operating Range (rpm)	800 to 2500 <sup>(1)</sup>
Number of Cylinders	4 In-Line
Bore	99 mm (3.89763 inch)
Stroke	110 mm (4.33070 inch)
Power	854F 45 kW to 55.4 kW (60.345 hp to 74.3 hp) 854E 62 kW to 86 kW (83.142 hp to 115.326 hp)
Aspiration	854F Turbocharged and Turbocharged charge cooled 854E Turbocharged charge cooled
Compression Ratio	17: 1
Displacement	3.4 L (207.48 cubic inch)
Firing Order	1-3-4-2
Rotation (flywheel end)	Counterclockwise

<sup>(1)</sup> The operating rpm depends on the engine rating, the application, and the configuration of the throttle.

## Engine Type and Aftertreatment Type

There are four different engine types and two different types of aftertreatment systems.

- JR\_\_\_\_\_854E-E34TA is a turbocharged, charge cooled engine, with a wall flow Diesel Particulate Filter (DPF).
- JS \_\_\_\_\_854F-E34T is a turbocharged engine with a wall flow DPF
- JT \_\_\_\_\_854F-E34T is a turbocharged engine with a through-flow DPF

- JV \_\_\_\_\_854F-E34TA is a turbocharged, charge cooled engine with a wall flow DPF

The JV model 854F-E34TA is a constant power output engine, rated at 2200 RPM.

The through-flow aftertreatment system DPF will not require a service period.

The wall flow aftertreatment system DPF will require a service period. For more information refer to this "Operation and Maintenance Manual" Maintenance Interval Schedule.

## Electronic Engine Features

The engine operating conditions are monitored. The Electronic Control Module (ECM) controls the response of the engine to these conditions and to the demands of the operator. These conditions and operator demands determine the precise control of fuel injection by the ECM. The electronic engine control system provides the following features:

- Engine monitoring
- Engine speed governing
- Control of the injection pressure
- Cold start strategy
- Automatic air/fuel ratio control
- Torque rise shaping
- Injection timing control
- System diagnostics
- Aftertreatment Regeneration

For more information on electronic engine features, refer to the Operation and Maintenance Manual, "Features and Controls" topic (Operation Section).

## Engine Diagnostics

The engine has built-in diagnostics to ensure that the engine systems are functioning correctly. The operator will be alerted to the condition by a "Stop or Warning" lamp. Under certain conditions, the engine horsepower and the vehicle speed may be limited. The electronic service tool may be used to display the diagnostic codes.

There are three types of diagnostic codes: active, logged, and event.

Most of the diagnostic codes are logged and stored in the ECM. For additional information, refer to the Operation and Maintenance Manual, "Engine Diagnostics" topic (Operation Section).

The ECM provides an electronic governor that controls the injector output to maintain the desired engine rpm.

## Engine Cooling and Lubrication

The cooling system and lubrication system consists of the following components:

- Belt driven centrifugal water pump
- Water temperature regulator which regulates the engine coolant temperature
- Gear-driven rotor type oil pump
- Multi-plate oil cooler

The engine lubricating oil is cooled and the engine lubricating oil is filtered.

## Engine Service Life

Engine efficiency and maximum utilization of engine performance depend on the adherence to proper operation and maintenance recommendations. In addition, use recommended fuels, coolants, and lubricants. Use the Operation and Maintenance Manual as a guide for required engine maintenance.

## Aftermarket Products and Perkins Engines

Perkins does not warrant the quality or performance of non-Perkins fluids and filters.

When auxiliary devices, accessories, or consumables (filters, additives, catalysts,) which are made by other manufacturers are used on Perkins products, the Perkins warranty is not affected simply because of such use.

**However, failures that result from the installation or use of other manufacturers devices, accessories, or consumables are NOT Perkins defects. Therefore, the defects are NOT covered under the Perkins warranty.**

## Aftertreatment System

The aftertreatment system is approved for use by Perkins. To be emission-compliant only, the approved Perkins aftertreatment system must be used on a Perkins engine.

## Product Identification Information

i04725109

### Plate Locations and Film Locations (Engine)

Perkins engines are identified by an engine serial number.

An example of an engine number is  
JR\*\*\*\*L000001V.

\*\*\*\* \_\_\_\_\_ The list number for the engine  
JR \_\_\_\_\_ The type of engine  
L \_\_\_\_\_ Built in the Italy  
000001 \_\_\_\_\_ Engine Serial Number  
V \_\_\_\_\_ Year of Manufacture

Perkins dealers or Perkins distributors need all of these numbers in order to determine the components that were included with the engine. This information permits accurate identification of replacement part numbers.

The numbers for fuel setting information for electronic engines are stored within the flash file. These numbers can be read by using the electronic service tool.

## Serial Number location

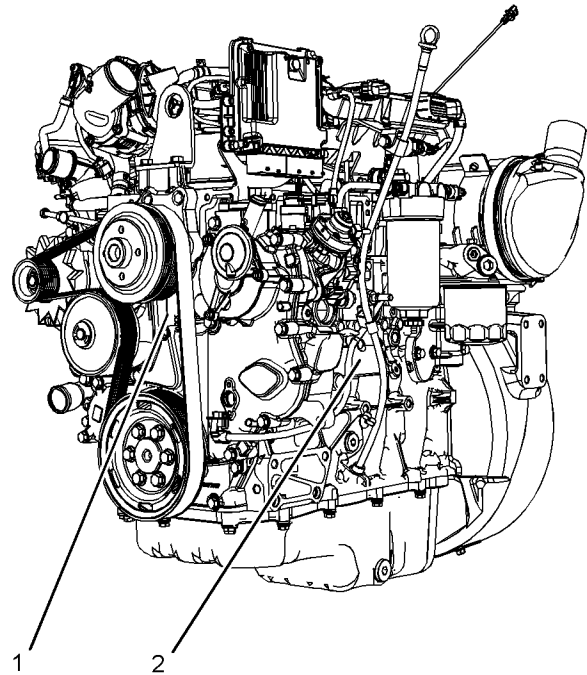

Illustration 22

g02474416

Typical example of a non-stressed cylinder block

The engine serial number can be installed in three different positions.

All engines will have the serial number install in location (1) on the front face of the engine.

On a non-stressed cylinder block the serial number is located in position (2). On the left-hand side on the cylinder block.

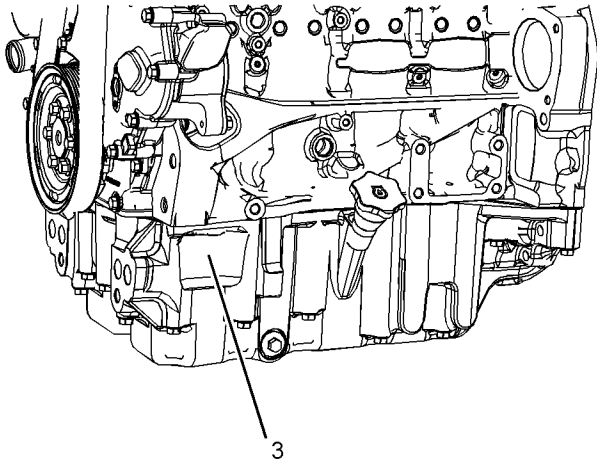

Illustration 23

g02826736

**Typical example**

On a stressed cylinder block the serial number is located in position (3).

The engine serial number is stamped on the emissions plate.

i05328112

## Plate Locations and Film Locations (Aftertreatment)

### Wall Flow Diesel Particulate Filter (DPF)

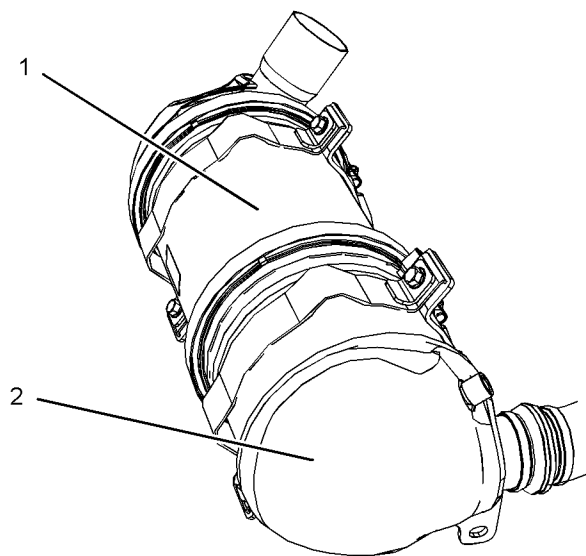

Illustration 24

g02475495

#### Typical example

The serial number for identifying the aftertreatment will be in two locations. On the DPF in position (1) and in position (2). On the end cover of the inlet to the DPF.

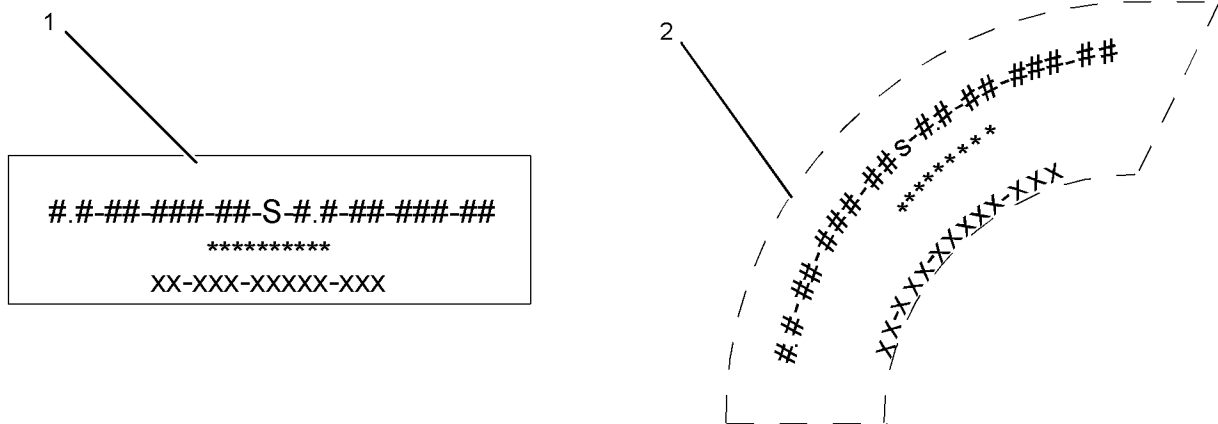

Illustration 25

g02723697

(1) Serial numbers on main body

(2) Serial numbers on inlet end cover

Ensure that all numbers on the aftertreatment are recorded.

Your Perkins distributor or your dealer will require all the numbers in order to identify the components for your aftertreatment.

i05328174

## Plate Locations and Film Locations (Aftertreatment)

### Through-Flow Diesel Particulate Filter (DPF)

A serial number label for identifying the through-flow DPF will be located on the main body of the DPF.

i04460799

### Emissions Certification Film

The emission label will be installed on the left side of the non-stressed cylinder block.



EMISSION CONTROL INFORMATION	
ENGINE FAMILY <input style="width: 50px;" type="text" value="####"/> MODEL <input style="width: 50px;" type="text" value="####"/> MANUFACTURE DATE (MO-YR) <input style="width: 80px;" type="text" value="####"/>	ENGINE TYPE <input style="width: 40px;" type="text" value="####"/> <input style="width: 40px;" type="text" value="####"/>
DISPLACEMENT <input style="width: 50px;" type="text" value="####"/> ADVERTISED POWER <input style="width: 50px;" type="text" value="####"/> KW@rpm POWER CATEGORY: <input style="width: 50px;" type="text" value="####"/>	SERIAL NUMBER <input style="width: 100px;" type="text" value="#### ####"/>
THIS ENGINE COMPLIES WITH US. EPA REGULATION FOR <input style="width: 50px;" type="text" value="####"/> MODEL YEAR NON ROAD AND STATIONARY DIESEL ENGINE AND CALIFORNIA REGULATION FOR <input style="width: 50px;" type="text" value="####"/> MODEL YEAR NON ROAD DIESEL ENGINES	E# <input style="width: 40px;" type="text" value="####"/> <input style="width: 40px;" type="text" value="####"/>
THIS ENGINE IS CERTIFIED TO OPERATE ON: ULTRA LOW SULFUR FUEL ONLY ECS: <input style="width: 50px;" type="text" value="####"/> <input style="width: 50px;" type="text" value="####"/>	<input style="width: 100px;" type="text" value="####"/>
MANUFACTURED BY FPT INDUSTRIAL S.P.A. IN ITALY	####    ####    ####

Illustration 26

g02646428

Typical example

i05324886

### Engine Aftertreatment System

Part Number \_\_\_\_\_

Serial Number \_\_\_\_\_

## Reference Information

Information for the following items may be needed to order parts. Locate the information for your engine. Record the information in the appropriate space. Make a copy of this list for a record. Keep the information for future reference.

### Record for Reference

Engine Model \_\_\_\_\_

Engine Serial Number \_\_\_\_\_

Engine Low Idle Revolutions Per Minute (RPM) \_\_\_\_\_

Engine Full Load RPM \_\_\_\_\_

Primary Fuel Filter \_\_\_\_\_

Secondary Fuel Filter Element \_\_\_\_\_

Lubrication Oil Filter Element \_\_\_\_\_

Auxiliary Oil Filter Element \_\_\_\_\_

Total Lubrication System Capacity \_\_\_\_\_

Total Cooling System Capacity \_\_\_\_\_

Air Cleaner Element \_\_\_\_\_

Drive Belt \_\_\_\_\_

## Operation Section

### Lifting and Storage

i07443564

#### Product Lifting

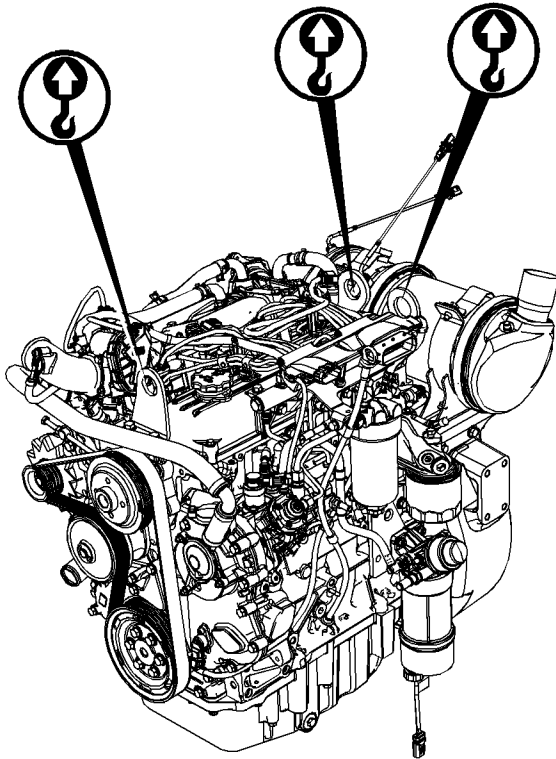

Illustration 27

g02475658

Typical example

#### NOTICE

Always inspect lifting eyebolts and all other lifting equipment for damage before performing any lifting. Never Bend the eyebolts and the brackets. Never perform product lifting if the components are damaged.

Use a hoist to remove heavy components. Use an adjustable lifting beam to lift the engine. All supporting members (chains and cables) should be parallel to each other. The chains and cables should be perpendicular to the top of the object that is being lifted.

Some removals require lifting the fixtures to obtain correct balance and safety.

To remove the engine, use the lifting eyes that are on the engine. Radiators that are approved by Perkins can be lifted with the engine.

Lifting eyes are designed and installed for specific engine arrangements. Alterations to the lifting eyes and/or the engine make the lifting eyes and the lifting fixtures obsolete. If alterations are made, ensure that correct lifting devices are provided. Consult your Perkins dealer or your Perkins distributor for information regarding fixtures for correct engine lifting.

**Note:** The engine is equipped with three lifting eyes. All the lifting eyes must be used to lift the engine.

i04084189

#### Product Storage (Engine and Aftertreatment)

Perkins are not responsible for damage which may occur when an engine is in storage after a period in service.

Your Perkins dealer or your Perkins distributor can assist in preparing the engine for extended storage periods.

#### Condition for Storage

The engine must be stored in a water proof building. The building must be kept at a constant temperature. Engines that are filled with Perkins ELC will have coolant protection to an ambient temperature of  $-36^{\circ}\text{C}$  ( $-32.8^{\circ}\text{F}$ ). The engine must not be subjected to extreme variations in temperature and humidity.

#### Storage Period

An engine can be stored for up to 6 months provided all the recommendation are adhered to.

#### Storage Procedure

Keep a record of the procedure that has been completed on the engine.

**Note:** Do not store an engine that has biodiesel in the fuel system.

1. Ensure that the engine is clean and dry.
  - a. If the engine has been operated using biodiesel, the system must be drained and new filters installed. The fuel tank will require flushing.
  - b. Fill the fuel system with an ultra low sulfur fuel. For more information on acceptable fuels refer to this Operation and Maintenance Manual,

“Fluid recommendations”. Operate the engine for 15 minutes in order to remove all biodiesel from the system.

2. Drain any water from the primary filter water separator. Ensure that the fuel tank is full.
3. The engine oil will not need to be drained in order to store the engine. Provided the correct specification of engine oil is used the engine can be stored for up to 6 months. For the correct specification of engine oil refer to this Operation and Maintenance Manual, “Fluid recommendations”.
4. Remove the drive belt from the engine.

### **Sealed Coolant System**

Ensure that the cooling system is filled with Perkins ELC, or an antifreeze that meets “ASTM D6210” specification.

### **Open Cooling System**

Ensure that all cooling drain plugs have been opened. Allow the coolant to drain. Install the drain plugs. Place a vapor phase inhibitor into the system. The coolant system must be sealed once the vapor phase inhibitor has been introduced. The effect of the vapor phase inhibitor will be lost if the cooling system is open to the atmosphere.

For maintenance procedures ref to this Operation and Maintenance Manual.

### **Aftertreatment**

No special procedures are required. The exhaust outlet of the aftertreatment should be capped. Before storing, the engine and the aftertreatment must be enclosed in a cover.

### **Monthly Checks**

The crankshaft must be rotated in order to change the spring loading on the valve train. Rotate the crankshaft more than 180 degrees. Visibly check for damage or corrosion to the engine and aftertreatment.

Ensure that the engine and aftertreatment are covered completely before storage. Log the procedure in the record for the engine.

## Features and Controls

i05324913

### Alarms and Shutoffs

The alarm is a warning to the operator that an abnormal operating condition has occurred. The shutoffs are set in order to protect the engine from damage. A shutoff can be triggered by pressure, temperature, engine speed, and electronic fault.

The operator should become familiar with the warning lamps and shutdown lamps on the installed control panel before operating the application. For more information refer to this Operation and Maintenance Manual, "Monitoring System (Table for the Indicator lamps)".

i04316262

### Gauges and Indicators

Your engine may not have the same gauges or all of the gauges that are described. For more information about the gauge package, see the OEM information.

Gauges provide indications of engine performance. Ensure that the gauges are in good working order. Determine the normal operating range by observing the gauges over a period.

Noticeable changes in gauge readings indicate potential gauge or engine problems. Problems may also be indicated by gauge readings that change even if the readings are within specifications. Determine and correct the cause of any significant change in the readings. Consult your Perkins distributor for assistance.

Some engine applications are equipped with Indicator Lamps. Indicator lamps can be used as a diagnostic aid. There are two lamps. One lamp has an orange lens and the other lamp has a red lens.

These indicator lamps can be used in two ways:

- The indicator lamps can be used to identify the current operational status of the engine. The indicator lamps can also indicate that the engine has a fault. This system is automatically operated via the ignition switch.
- The indicator lamps can be used to identify active diagnostic codes. This system is activated by pressing the Flash Code button.

Refer to the Troubleshooting Guide, "Indicator Lamps" for further information.



**Jacket Water Coolant Temperature – Typical temperature range is 79° to 94°C (174° to 201 °F). This temperature range will vary according to engine load and the ambient temperature.**

A 100 kPa (14.5 psi) radiator cap must be installed on the cooling system. The maximum temperature for the cooling system will depend on engine power. For engines that are 75kW and lower the maximum cooling temperature is 110° C (230° F). For engines that are above 75kW the maximum temperature is 108° C (226.4° F). The engine coolant temperature is regulated by the engine sensors and the engine ECM. This programming cannot be altered. An engine derate can occur if the maximum engine coolant temperature is exceeded.

If the engine is operating above the normal range, reduce the engine load. If high coolant temperatures are a frequent event, perform the following procedures:

1. Reduce the load and the engine rpm.
2. Determine if the engine must be shut down immediately or if the engine can be cooled by reducing the load.
3. Inspect the cooling system for leaks. If necessary, consult your Perkins distributor for assistance.



**Tachometer – This gauge indicates engine speed (rpm). When the throttle control lever is moved to the full throttle position without load, the engine is running at high idle. The engine is running at the full load rpm when the throttle control lever is at the full throttle position with maximum rated load.**

#### NOTICE

To help prevent engine damage, never exceed the high idle rpm. Overspeeding can result in serious damage to the engine. Operation at speeds exceeding high idle rpm should be kept to a minimum.



**Ammeter – This gauge indicates the amount of charge or discharge in the battery charging circuit. Operation of the indicator should be to the "+" side of "0" (zero).**



**Fuel Level – This gauge indicates the fuel level in the fuel tank. The fuel level gauge operates when the "START/STOP" switch is in the "on" position.**



**Service Hour Meter – The gauge indicates total operating hours of the engine.**

## Indicator Lamps

- Shutdown lamp
- Warning lamp
- Wait to start lamp
- Low oil pressure lamp (On solid) and engine oil reset lamp (Flashing)

For information, refer to this manual, “Monitoring System (Table for the Indicator Lamps)” for the sequence of operation of the shutdown lamp and the warning lamp.

The function of the wait to start lamp is automatically controlled at engine start-up.

The low oil pressure lamp has two functions.

- The low oil pressure lamp is controlled by the engine ECM. If low oil pressure is detected, the lamp will be illuminated on solid. The reason for the illumination of the low-pressure lamp should be investigated immediately.
- Low oil pressure lamp flashing, an engine oil change is required. The lamp must be reset, refer to this Operation and Maintenance Manual, “Engine Oil and Filter - Change” for more information.

All lamps will illuminate for 2 seconds in order to check that the lamps are functioning when the keyswitch is turned to the ON position. If any of the lamps stay illuminated, the reason for illumination should be investigated immediately.

## Aftertreatment Lamps

For information on the aftertreatment lamp, refer to this Operation and Maintenance Manual, “Diesel Particulate Filter Regeneration”.

i04317185

## Monitoring System

### WARNING

**If the Shutdown mode has been selected and the warning indicator activates, engine shutdown may take as little as 20 seconds from the time the warning indicator is activated. Depending on the application, special precautions should be taken to avoid personal injury. The engine can be re-started following shutdown for emergency maneuvers, if necessary.**

### NOTICE

The Engine Monitoring System is not a guarantee against catastrophic failures. Programmed delays and derate schedules are designed to minimize false alarms and provide time for the operator to stop the engine.

The following parameters are monitored:

- Coolant temperature
- Intake manifold air temperature
- Intake manifold air pressure
- Oil pressure
- Pressure in the fuel rail
- Engine speed/timing
- Fuel temperature
- Atmospheric pressure (Barometric pressure)
- Water in fuel switch
- Inlet temperature of the diesel oxidation catalyst
- Inlet temperature of the diesel particulate filter
- Differential pressure in the diesel particulate filter
- The amount of soot in the diesel particulate filter

## Programmable Options and Systems Operation

### WARNING

**If the Warning/Derate/Shutdown mode has been selected and the warning indicator activates, bring the engine to a stop whenever possible. Depending on the application, special precautions should be taken to avoid personal injury.**

The engine can be programmed to the following modes:

### “Warning”

The orange “Warning” lamp will turn “ON” and the warning signal is activated continuously in order to alert the operator that one or more of the engine parameters is not within normal operating range.

### “Derate”

The orange “Warning” lamp will turn “ON” and the red shutdown lamp will be flashing. After the warning, the engine power will be derated. The warning lamp will begin to flash when the derating occurs.

The engine will be derated if the engine exceeds preset operational limits. The engine derate is achieved by restricting the amount of fuel that is available for each injection. The amount of this reduction of fuel is dependent on the severity of the fault that has caused the engine derate, typically up to a limit of 50%. This reduction in fuel results in a predetermined reduction in engine power.

### **“Shutdown”**

The orange warning will turn “ON” and the red shutdown lamp will also turn “ON” . After the warning, the engine power will be derated. The engine will continue at the rpm of the set derate until a shutdown of the engine occurs. The engine can be restarted after a shutdown for use in an emergency.

A shutdown of the engine may occur in as little as 20 seconds. The engine can be restarted after a shutdown for use in an emergency. However, the cause of the initial shutdown may still exist. The engine may shut down again in as little as 20 seconds.

If there is a signal for high coolant temperature, there will be a 2 second delay in order to verify the condition.

If there is a signal for low oil pressure, there will be a 2 second delay in order to verify the condition.

For information on the operation of the warning lamps and the shutdown lamp, refer to this Operation and Maintenance Manual, “ Monitoring System (Table for Indicator Lamps)”. For each of the programmed modes, refer to Troubleshooting Guide, “Indicator Lamps” for more information on Indicator Lamps.

For more information or assistance for repairs, consult your Perkins distributor or your Perkins dealer.

i04710837

## **Monitoring System** **(Table for the Indicator lamps)**

When in operation the amber warning indicator has three states, on solid, flashing and fast flashing. The sequence is to give a visual indication of the importance of the warning. Some application can have an audible warning installed.

Table 2

Warning Indicator	Shutdown Indicator	Lamp State	Description of the Indication	Engine Status	Operator Action
On	On	Indicator Check	When the keyswitch is moved to the ON position, the lamps will illuminate for 2 seconds and the lamps will then go off.  <b>During indicator check, the after-treatment indicators will also be checked.</b>	The keyswitch is in the ON position but the engine has not yet been cranked.	If any of the indicators will not illuminate during indicator check, the fault must be investigated immediately.  If any Indicators stay illuminated or flash, the fault must be investigated immediately.
Off	Off	No Faults	With the engine in operation, there are no active warnings, diagnostic codes, or event codes.	The engine is operating with no detected faults.	None
<b>Level 1</b>					
On Solid	Off	Warning	Level 1 warning	The engine is operating normally but there is one or more faults with the electronic management system for the engine.	As soon as possible the fault should be investigated.
<b>Level 2</b>					
Flashing	Off	Warning	Level 2 warning	The engine continues to be operated, but there are active diagnostic, or event codes active. Derate to engine power may be applied.	Stop the engine. Investigate the code.
<b>Level 3</b>					
Flashing	On solid	Warning	Level 3 warning If both the warning lamp and the shutdown lamp are in operation, this issue indicates one of the following conditions.  1. One or more of the shutdown values for the engine protection strategy has been exceeded.  2. A serious active diagnostic code has been detected.  3. After a short time period, the engine may shut down.	The engine continues to be operated, but the level of importance of the warning has increased. The engine will automatically shut down. If shut down is not enabled, the engine could be damaged if continued to be operated.	Stop the engine immediately. Investigate the fault

i04348489

## Overspeed

- ECM \_\_\_\_\_ Electronic Control Module
- RPM \_\_\_\_\_ Revolutions Per Minute

An overspeed is detected by the speed/timing sensors.

The default overspeed is set at 2800. The ECM will cut the power to the electronic unit injectors, until the rpm drops below the overspeed setting. A diagnostic fault code will be logged into the ECM memory and a warning lamp will indicate a diagnostic fault code. Some application may have a display panel in order to alert the operator.

i05325438

## Sensors and Electrical Components

### Full Engine Views

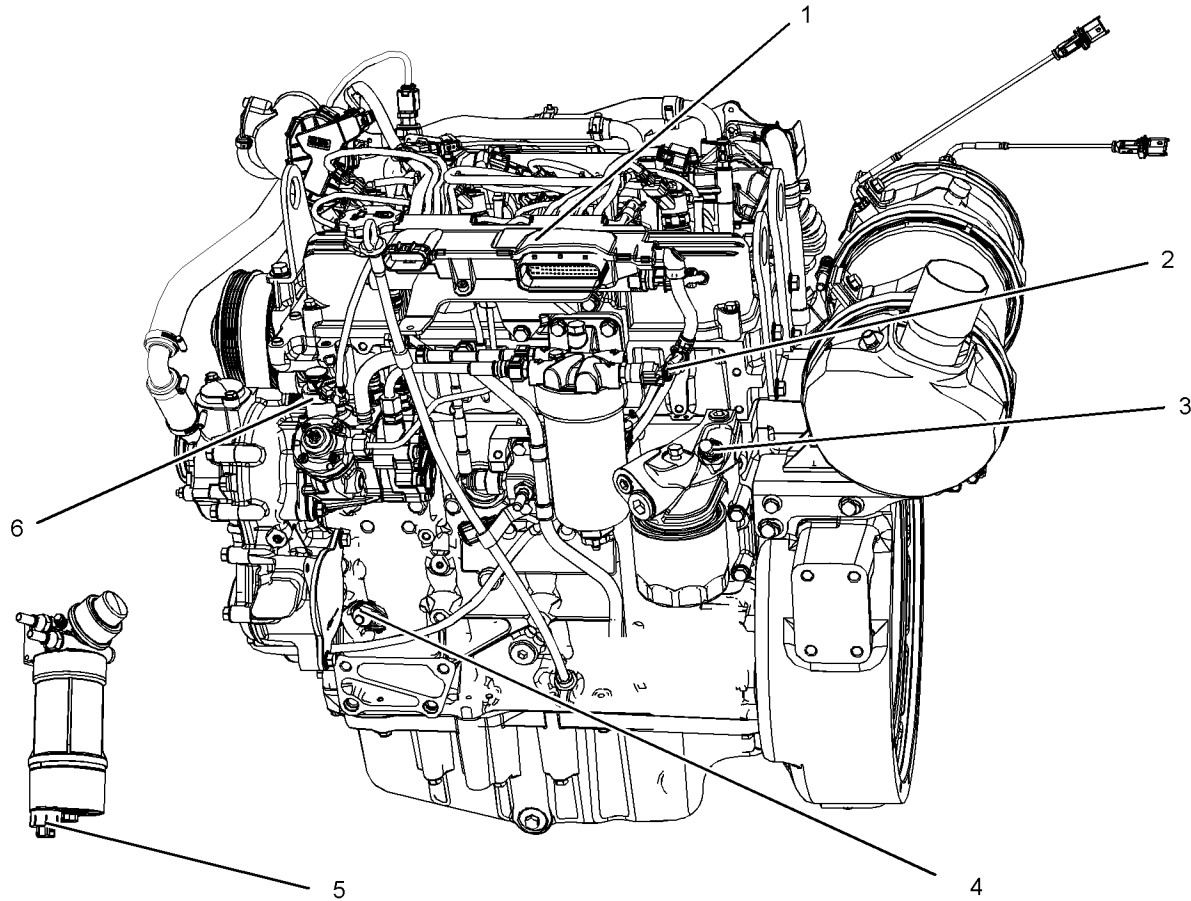

Illustration 28

g03373765

#### Typical example

- (1) 10 Pin and 62 pin connector
- (2) Fuel temperature sensor
- (3) Oil pressure switch

- (4) Primary speed/timing sensor (crankshaft position sensor)
- (5) Water in fuel switch

- (6) Fuel metering valve



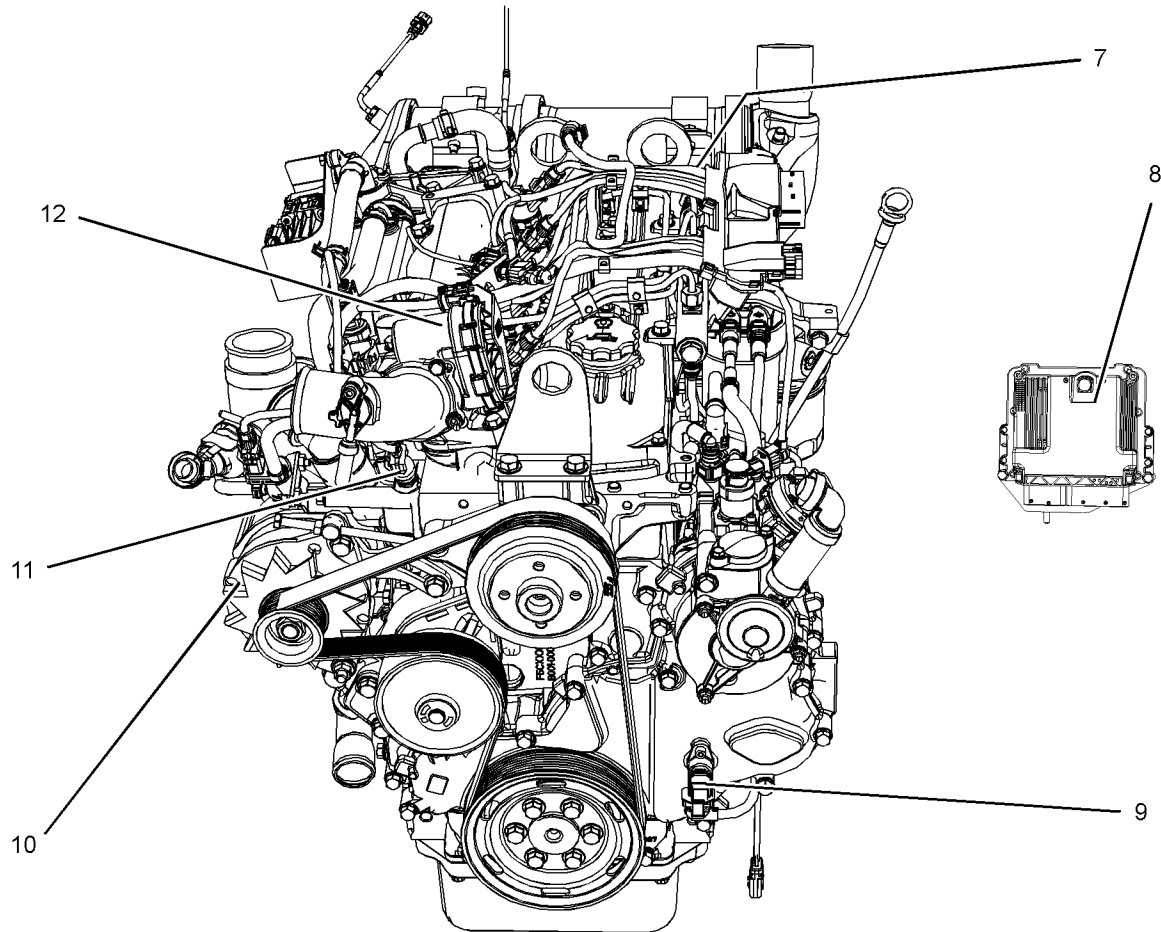

Illustration 29

g02477200

**Typical example**

(7) Fuel manifold (rail) pressure sensor  
(8) Electronic control module

(9) Secondary speed/timing sensor  
(camshaft position sensor)  
(10) Alternator

(11) Coolant temperature sensor  
(12) Intake throttle valve

Operation Section  
Sensors and Electrical Components

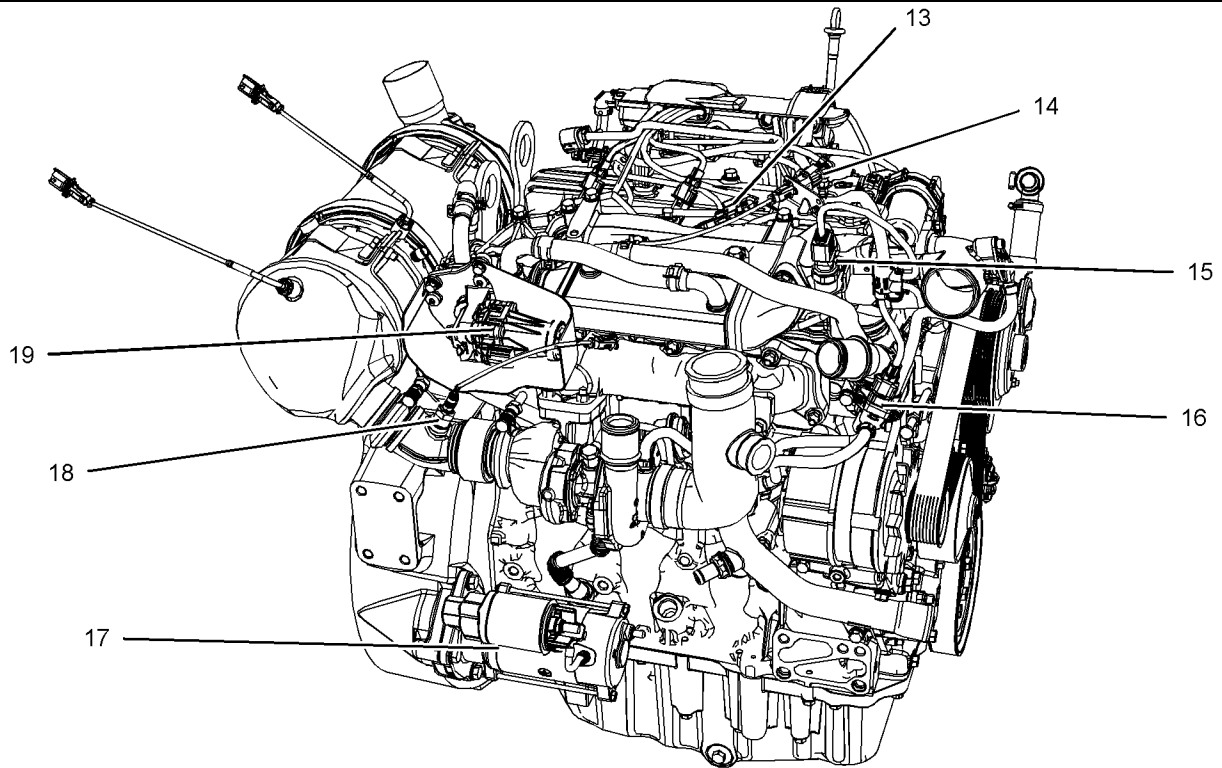

Illustration 30

g02529496

### Typical example

(13) Inlet manifold pressure and temperature sensor.  
(14) Exhaust temperature sensor connection

(15) Exhaust pressure sensor  
(16) Waste gate regulator  
(17) Starting motor  
(18) Oxygen sensor

(19) Control valve for the NOx reduction system

**Note:** Item (13), lower powered engines have separate inlet manifold pressure sensors and inlet manifold temperature sensors.

### Engine View Low Power with Separate Inlet Pressure and Inlet Temperature

---

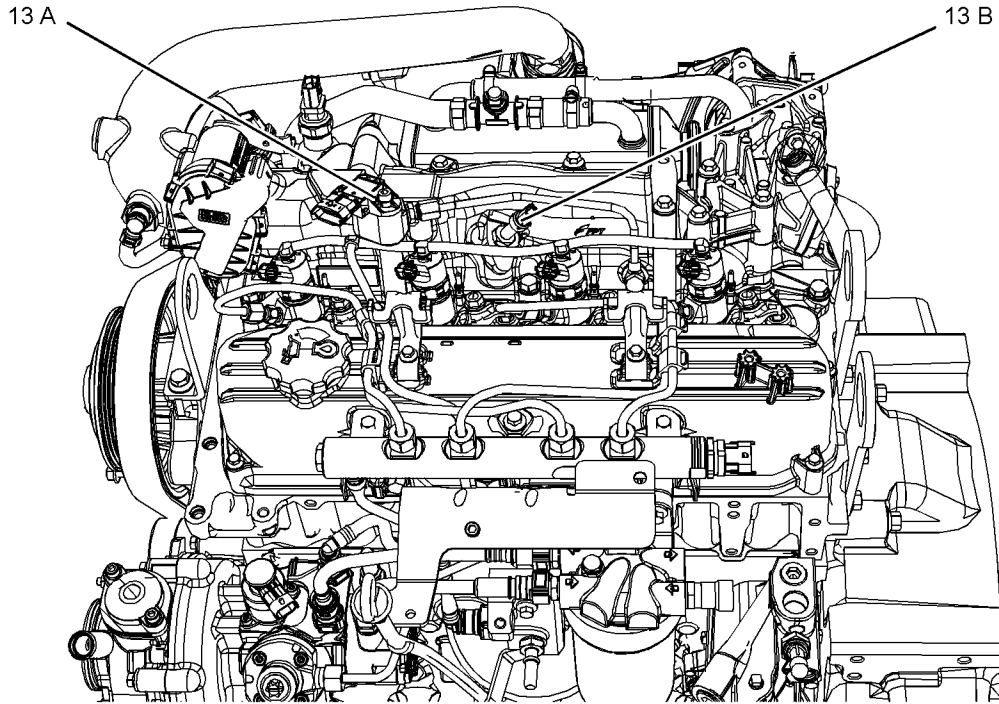

---

Illustration 31

g03373789

Typical example

(13 A) Inlet pressure sensor

(13 B) Inlet temperature sensor

## Location Views

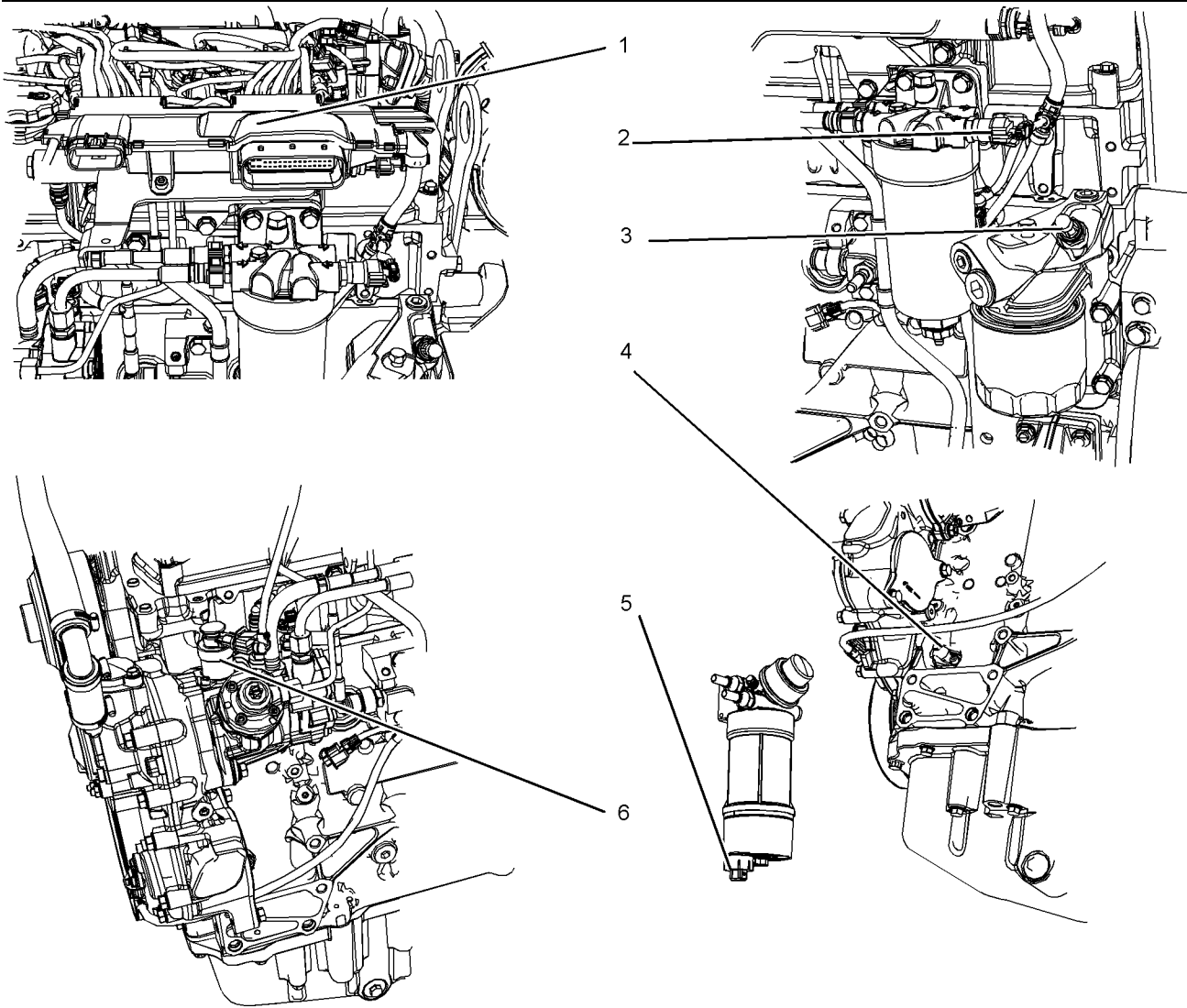

Illustration 32

g03373767

### Typical example

- (1) 10 Pin and 62 pin connector
- (2) Fuel temperature sensor
- (3) Oil pressure switch

- (4) Primary speed/timing sensor (crankshaft position sensor)
- (5) Water in fuel switch

- (6) Fuel metering valve

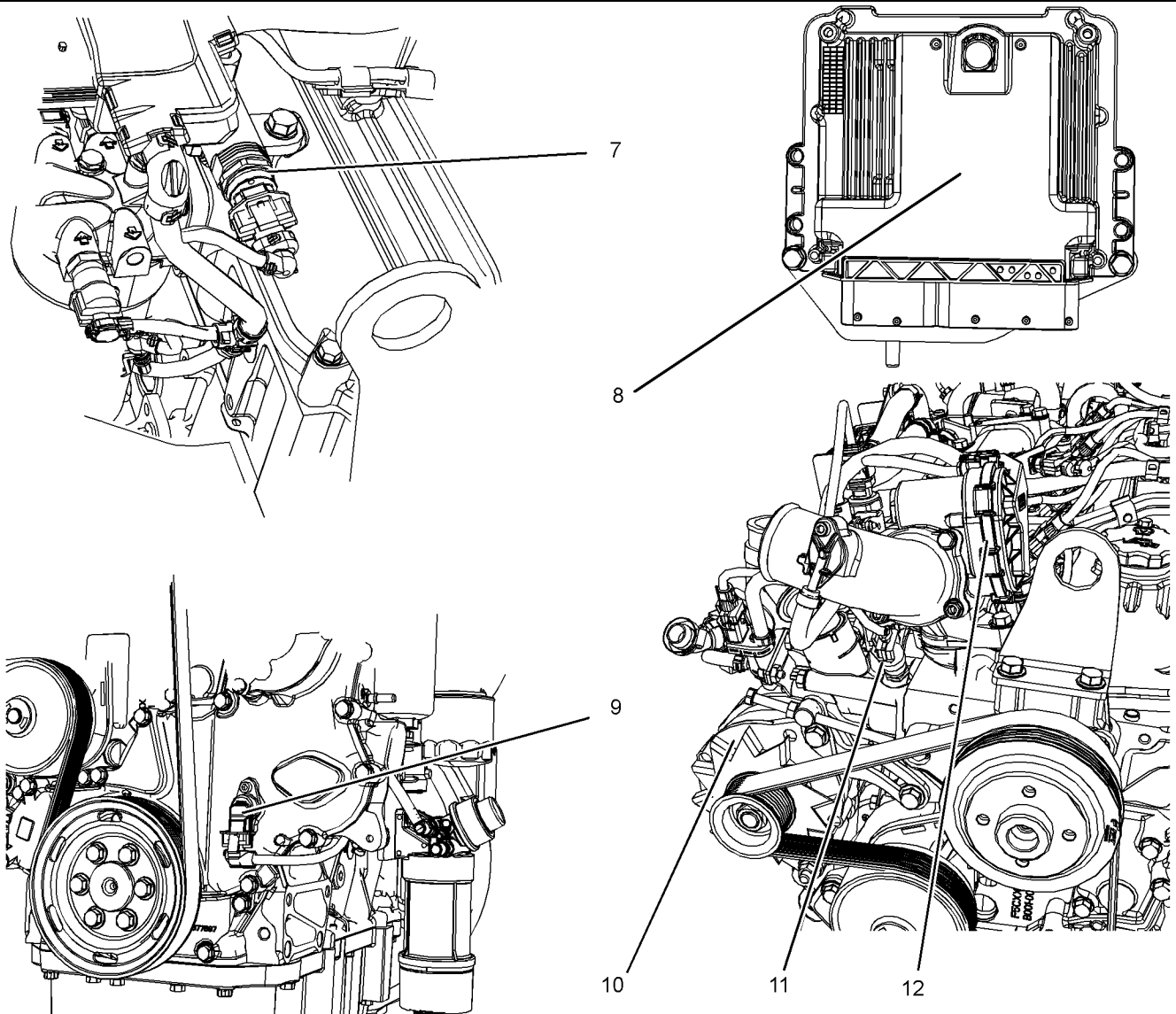

Illustration 33

g02529820

Typical example

- (7) Fuel manifold (rail) pressure sensor
- (8) Electronic control module

- (9) Secondary speed/timing sensor  
(camshaft position sensor)
- (10) Alternator

- (11) Coolant temperature sensor
- (12) Intake throttle valve

**Note:** The location of item (8) the engine electronic control module will depend on the application.

Operation Section  
Sensors and Electrical Components

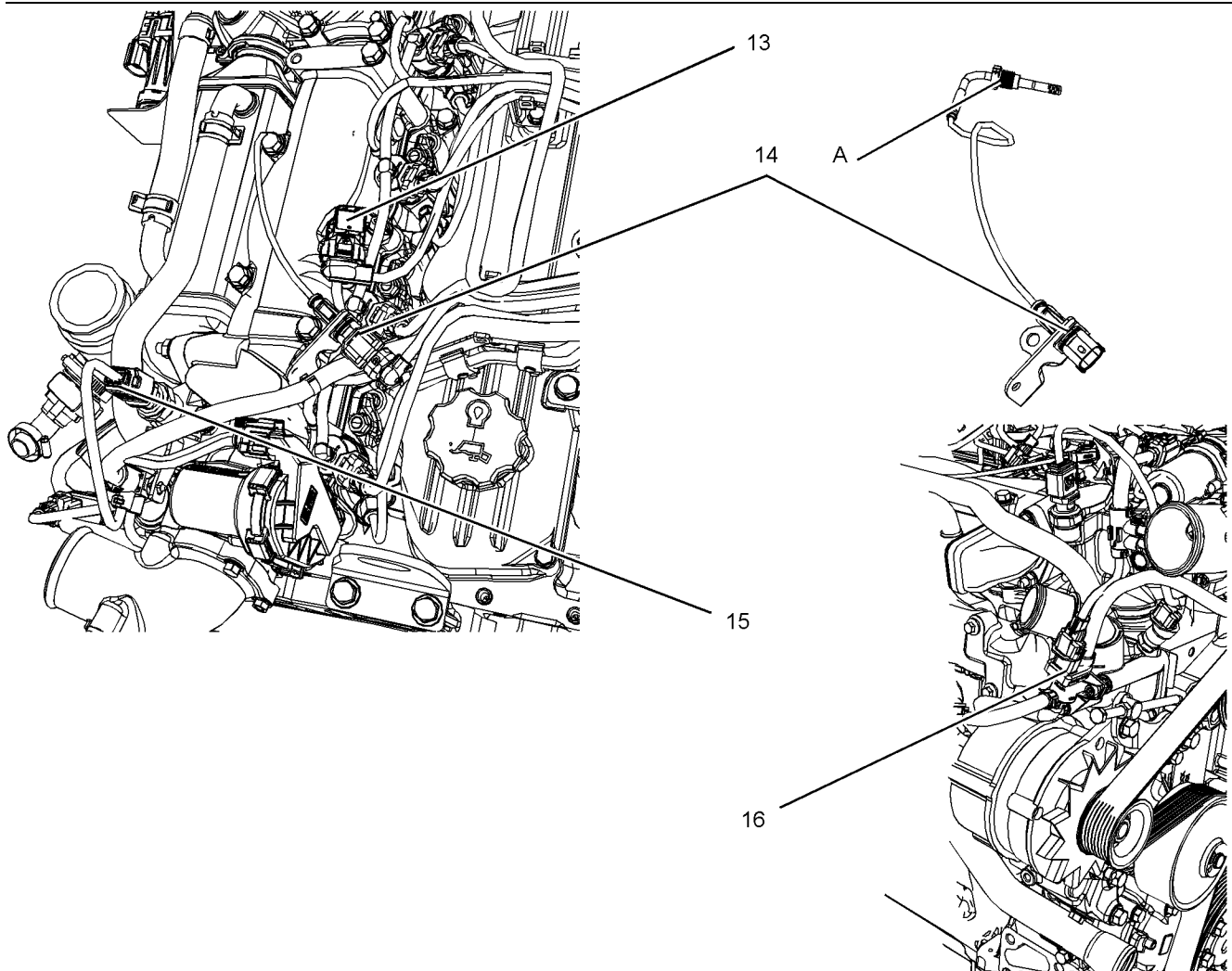

Illustration 34

g02529821

Typical example

(13) Inlet manifold pressure and temperature sensor.

(14) Exhaust temperature sensor connection  
(A) Exhaust temperature sensor

(15) Exhaust pressure sensor  
(16) Waste gate regulator

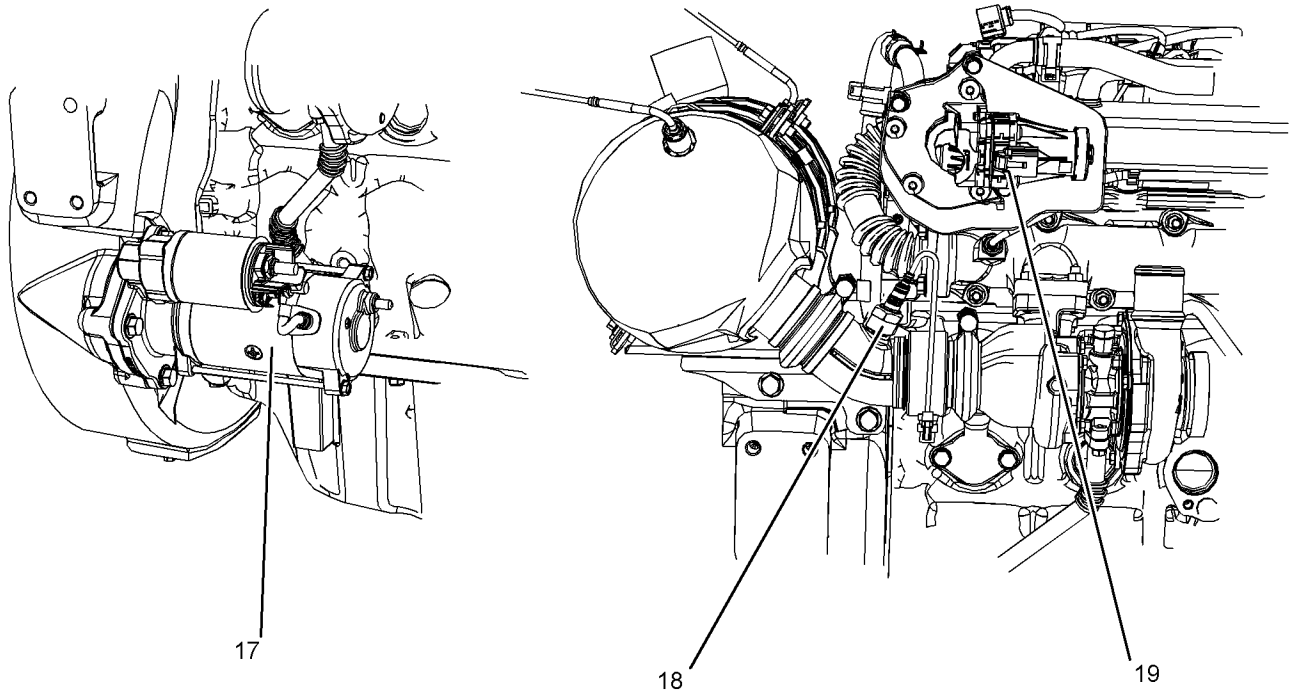

Illustration 35

g02530397

**Typical example**

(17) Starting motor

(18) Position for oxygen sensor

(19) NOx reduction control valve

**Note:** Some engines can have the air intake temperature sensor and the glow plug control unit supplied loose.

## Separate Inlet Pressure and Inlet Temperature Views

---

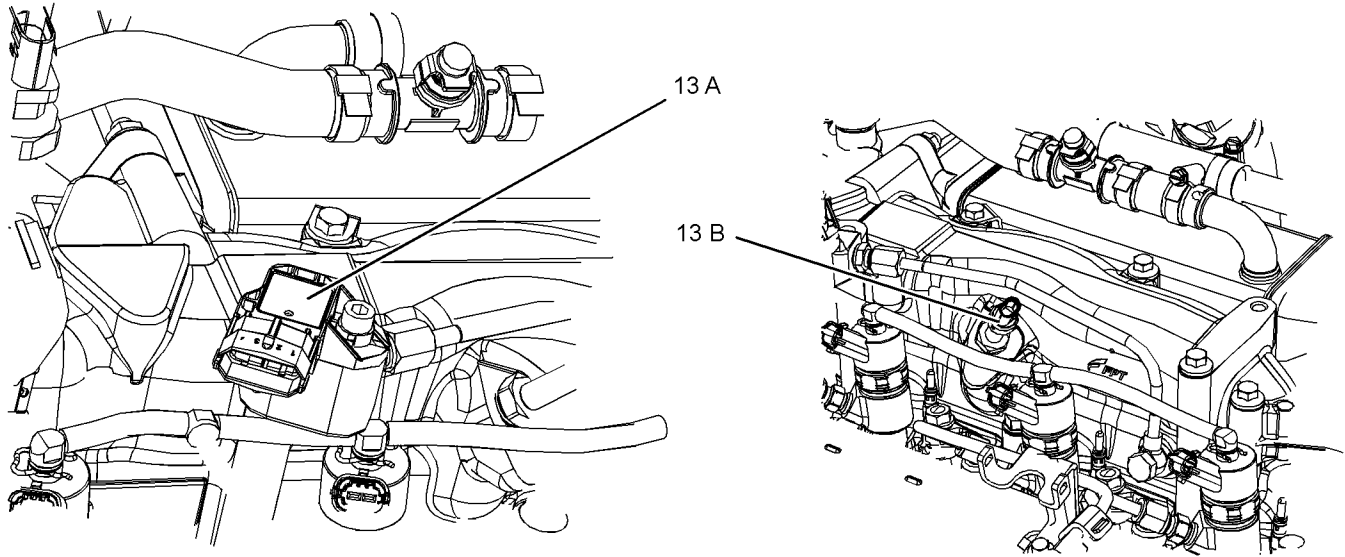

---

Illustration 36

g03373791

### Typical example

(13 A) Intake manifold pressure sensor

(13 B) Intake manifold temperature sensor



---

**Engine Option or Parts that are Supplied Loose**

---

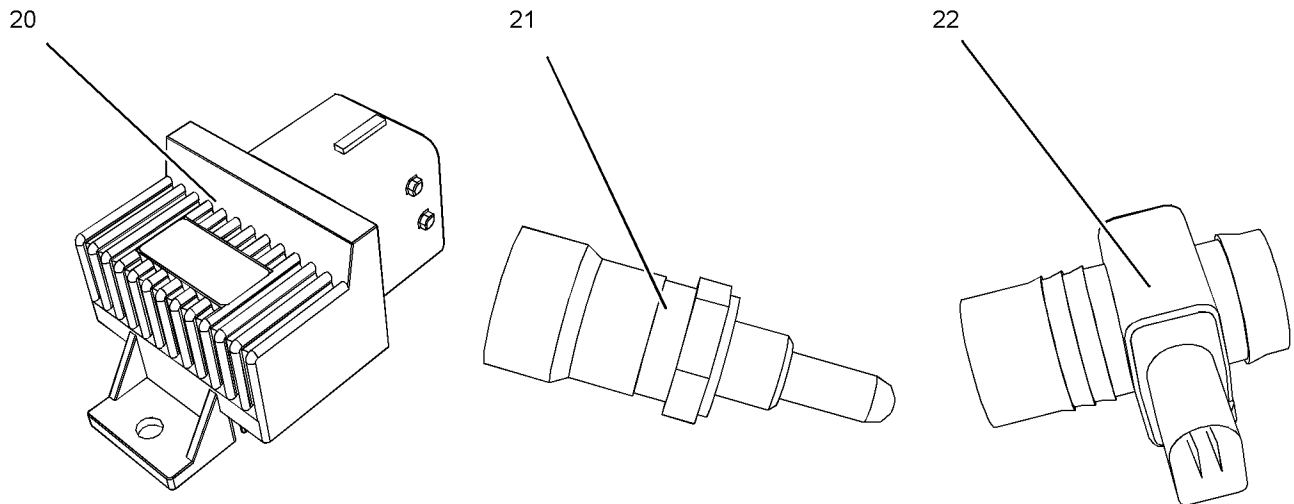

Illustration 37

g02821639

Typical example

(20) Glow plug control unit

(21) Inlet air temperature sensor

(22) Breather heater

Some engines can have a breather heater (22) for the crankcase breather installed.

i05325624

## Sensors and Electrical Components (Aftertreatment)

There are two types of aftertreatment that can be installed. The engine power will determine the type of aftertreatment that is installed.

## Wall Flow Aftertreatment

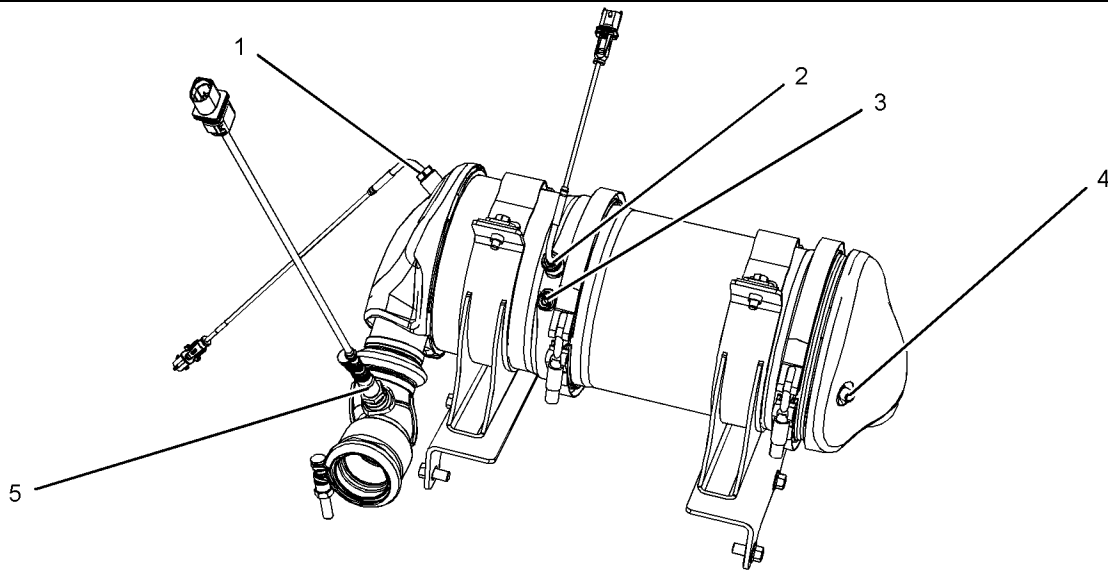

Illustration 38

g03373851

### Typical example

- |  |  |                   |
|--|--|-------------------|
| (1) Diesel oxidation catalyst temperature sensor       | (3) Inlet connection for the differential pressure sensor  | (5) Oxygen sensor |
| (2) Diesel particulate filter (DPF) temperature sensor | (4) Outlet connection for the differential pressure sensor |                   |

## Through Flow Aftertreatment

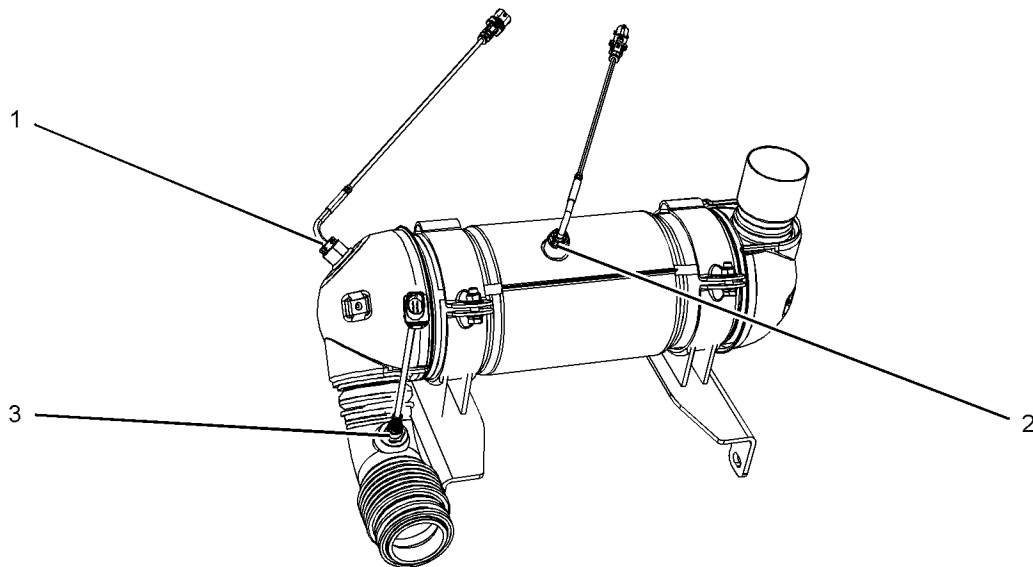

Illustration 39

g03373872

### Typical example

- |  |                                  |
|--|----------------------------------|
| (1) Diesel oxidation catalyst (DOC) temperature sensor | (2) Temperature sensor after DOC |
|  | (3) Oxygen sensor                |

## Differential Pressure sensor

---

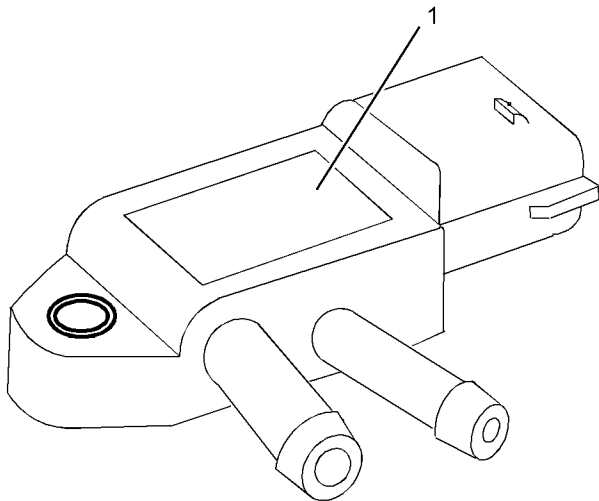

Illustration 40

g02477086

### Typical example

(1) Differential pressure sensor

The location of the differential pressure sensor will depend on the application. The differential pressure is installed on the wall flow DPF. The through-flow DPF does not always require the sensor to be installed.

# Engine Diagnostics

i04348749

## Self-Diagnostics

i02651093

Perkins electronic engines have the capability to perform a self-diagnostics test. When the system detects an active problem, a diagnostic lamp is activated. Diagnostic codes will be stored in permanent memory in the Electronic Control Module (ECM). The diagnostic codes can be retrieved by using the electronic service tool. Refer to Troubleshooting , “Electronic Service Tools” for further information.

Some installations have electronic displays that provide direct readouts of the engine diagnostic codes. Refer to the manual that is provided by the OEM for more information on retrieving engine diagnostic codes. Alternatively refer to Troubleshooting , “Indicator Lamps” for further information.

Active codes represent problems that currently exist. These problems should be investigated first.

Logged codes represent the following items:

- Intermittent problems
- Recorded events
- Performance history

The problems may have been repaired since the logging of the code. These codes do not indicate that a repair is needed. The codes are guides or signals when a situation exists. Codes may be helpful to troubleshoot problems.

When the problems have been corrected, the corresponding logged fault codes should be cleared.

i02651107

## Diagnostic Lamp

A diagnostic lamp is used to indicate the existence of an active fault. Refer to Troubleshooting , “Indicator Lamps” for more information. A fault diagnostic code will remain active until the problem is repaired. The diagnostic code may be retrieved by using the electronic service tool. Refer to Troubleshooting , “Electronic Service Tools” for more information.

## Fault Logging

The system provides the capability of Fault Logging. When the Electronic Control Module (ECM) generates an active diagnostic code, the code will be logged in the memory of the ECM. The codes that have been logged by the ECM can be identified by the electronic service tool. The active codes that have been logged will be cleared when the fault has been rectified or the fault is no longer active.

i03554534

## Engine Operation with Active Diagnostic Codes

If a diagnostic lamp illuminates during normal engine operation, the system has identified a situation that is not within the specification. Use electronic service tools to check the active diagnostic codes.

**Note:** If the customer has selected “DERATE” and if there is a low oil pressure condition, the Electronic Control Module (ECM) will limit the engine power until the problem is corrected. If the oil pressure is within the normal range, the engine may be operated at the rated speed and load. However, maintenance should be performed as soon as possible.

The active diagnostic code should be investigated. The cause of the problem should be corrected as soon as possible. If the cause of the active diagnostic code is repaired and there is only one active diagnostic code, the diagnostic lamp will turn off.

Operation of the engine and performance of the engine can be limited as a result of the active diagnostic code that is generated. Acceleration rates may be significantly slower. Refer to the Troubleshooting Guide for more information on the relationship between these active diagnostic codes and engine performance.

i01902995

## Engine Operation with Intermittent Diagnostic Codes

If a diagnostic lamp illuminates during normal engine operation and the diagnostic lamp shuts off, an intermittent fault may have occurred. If a fault has occurred, the fault will be logged into the memory of the Electronic Control Module (ECM).

In most cases, it is not necessary to stop the engine because of an intermittent code. However, the operator should retrieve the logged fault codes and the operator should reference the appropriate information in order to identify the nature of the event. The operator should log any observation that could have caused the lamp to light.

- Low power
- Limits of the engine speed
- Excessive smoke, etc

This information can be useful to help troubleshoot the situation. The information can also be used for future reference. For more information on diagnostic codes, refer to the Troubleshooting Guide for this engine.

i05844821

## Configuration Parameters

The engine electronic control module (ECM) has two types of configuration parameters. The system configuration parameters and the customer specified parameters.

The electronic service tool is required in order to alter the configuration parameters.

### System Configuration Parameters

System configuration parameters affect the emissions of the engine or the power of the engine. System configuration parameters are programmed at the factory. Normally, system configuration parameters would never require changing through the life of the engine. System configuration parameters must be reprogrammed if an ECM is replaced.

### Customer Specified Parameters

Customer specified parameters allow the engine to be configured to the exact needs of the application.

The electronic service tool is required in order to alter the customer configuration parameters.

Customer parameters may be changed repeatedly as operational requirements change.

Table 3

Customer Specified Parameters	
Specified Parameters	Record
Low Idle Speed	

(continued)

Operation Section  
Configuration Parameters

(Table 3, contd)

Throttle Position 1 Engine Speed	
Throttle Position 2 Engine Speed	
Throttle Position 3 Engine Speed	
Throttle Position 4 Engine Speed	
Engine Idle Shutdown Enable Status	
Engine Idle Shutdown Delay Status	
Throttle Lock Feature Installation Status	
Multi State Input Switch Enable Status	
Multi State Input Switch Control Purpose	
Multi Position Throttle Switch Initialization Enable Status	
Throttle Lock Engine Set Speed #1	
Throttle Lock Increment Speed Ramp Rate	
Throttle Lock Decrement Speed Ramp Rate	
Throttle Lock Engine Set Speed Increment	
Monitoring Mode Shutdowns	
Limp Home Desired Engine Speed	
Engine Acceleration Rate	
Engine Location	
High Exhaust System Temperature Indicator Installation Status	
Oil Pressure Lamp Installation Status	
Wait to Start Lamp Installation Status	
Warning Lamp Installation Status	
Shutdown Lamp Installation Status	
Starter Relay Installation Status	
Low Pressure Fuel Pump Installation Status	
Remote Torque Speed Control Enable Status	
Throttle Arbitration Method	
Manual Throttle Arbitration Precondition Check	
Throttle Enable Status	
Throttle #1 Initial Lower Position	
Throttle #1 Initial Upper Position	
Throttle #1 Idle Validation Switch Enable Status	
Throttle #1 Idle Validation Minimum Off Threshold	
Throttle #1 Idle Validation Maximum On Threshold	
Throttle #1 Lower Diagnostic Limit	
Throttle #1 Upper Diagnostic Limit	
Throttle #2 Initial Lower Position	

(continued)

(Table 3, contd)

Throttle #2 Initial Upper Position	
Throttle #2 Idle Validation Switch Enable Status	
Throttle #2 Idle Validation Minimum Off Threshold	
Throttle #2 Idle Validation Maximum On Threshold	
Throttle #2 Lower Diagnostic Limit	
Throttle #2 Upper Diagnostic Limit	
Engine Operation Mode #1 High Idle Speed	
Engine Operation Mode #1 High Idle Droop Percentage	
Engine Operation Mode #1 Throttle #1 Droop Percentage	
Engine Operation Mode #1 Throttle #2 Droop Percentage	
Engine Operation Mode #1 TSC1 Droop Percentage	
Engine Operation Mode #2 High Idle Speed	
Engine Operation Mode #2 High Idle Droop Percentage	
Engine Operation Mode #2 Throttle #1 Droop Percentage	
Engine Operation Mode #2 Throttle #2 Droop Percentage	
Engine Operation Mode #2 TSC1 Droop Percentage	
Engine Operation Mode #3 High Idle Droop Percentage	
Engine Operation Mode #3 High Idle Droop Percentage	
Engine Operation Mode #3 Throttle #1 Droop Percentage	
Engine Operation Mode #3 Throttle #2 Droop Percentage	
Engine Operation Mode #3 TSC1 Droop Percentage	
Engine Operation Mode #4 High Idle Speed	
Engine Operation Mode #4 High Idle Droop Percentage	
Engine Operation Mode #4 Throttle #1 Droop Percentage	
Engine Operation Mode #4 Throttle #2 Droop Percentage	
Engine Operation Mode #4 TSC1 Droop Percentage	

# Engine Starting

i05365825

i03648917

## Before Starting Engine

Perform the required daily maintenance and other periodic maintenance before the engine is started. Inspect the engine compartment. This inspection can help prevent major repairs at a later date. Refer to the Operation and Maintenance Manual, "Maintenance Interval Schedule" for more information.

- Ensure that the engine has an adequate fuel supply.
- Open the fuel supply valve (if equipped).

### NOTICE

All valves in the fuel return line must be open and fuel supply lines must be open. Damage to the fuel system can occur if fuel lines are closed with the engine in operation.

If the engine has not been started for several weeks, fuel may have drained from the fuel system. Air may have entered the filter housing. Also, when fuel filters have been changed, some air pockets will be trapped in the engine. In these instances, prime the fuel system. Refer to the Operation and Maintenance Manual, "Fuel System - Prime" for more information on priming the fuel system. Also, check that the fuel specification is correct and that the fuel condition is correct. Refer to the Operation and Maintenance Manual, "Fuel Recommendations".

### WARNING

**Engine exhaust contains products of combustion which may be harmful to your health. Always start and operate the engine in a well ventilated area and, if in an enclosed area, vent the exhaust to the outside.**

- Do not start the engine or move any of the controls if there is a "DO NOT OPERATE" warning tag or similar warning tag attached to the start switch or to the controls.
- Reset all of the shutoffs or alarm components.
- Ensure that any driven equipment has been disengaged. Minimize electrical loads or remove any electrical loads.

## Cold Weather Starting

### WARNING

**Do not use aerosol types of starting aids such as ether. Such use could result in an explosion and personal injury.**

The ability to start the engine will be improved at temperatures below  $-18^{\circ}\text{C}$  ( $0^{\circ}\text{F}$ ) from the use of a jacket water heater or extra battery capacity.

When Group 2 diesel fuel is used, the following items provide a means of minimizing starting problems and fuel problems in cold weather: Engine oil pan heaters, jacket water heaters, fuel heaters and fuel line insulation.

Use the procedure that follows for cold weather starting.

**Note:** Do not adjust the engine speed control during start-up. The electronic control module (ECM) will control the engine speed during start-up.

1. Disengage any driven equipment.

**Note:** During key ON, the indicator lamps will be illuminated for 2 seconds in order to check the lamp operation. If any of the indicator lamps do not illuminate check the bulb. If any indicator lamps stay illuminated or flash, refer to Troubleshooting, "Indicator Lamp Circuit - Test".

2. Turn the keyswitch to the RUN position. Leave the keyswitch in the RUN position until the warning light for the glow plugs is extinguished.
3. When the warning light for the glow plugs is extinguished, turn the keyswitch to the START position in order to engage the electric starting motor and crank the engine.

**Note:** The operating period of the warning light for the glow plugs will change due to the ambient air temperature.

### NOTICE

Do not engage the starting motor when flywheel is turning. Do not start the engine under load.

If the engine fails to start within 30 seconds, release the starter switch or button and wait two minutes to allow the starting motor to cool before attempting to start the engine again.

4. Allow the keyswitch to return to the RUN position after the engine starts.



- Repeat step 2 through step 4 if the engine fails to start.

**Note:** After starting, the engine will be held at low speed. The time held at low speed will depend on ambient temperature and time since last run. The procedure is in order to allow the engine systems to stabilize. The engine should not be “raced” in order to speed up the warm-up process.

- Allow the engine to idle for 3 to 5 minutes, or allow the engine to idle until the water temperature indicator begins to rise. When idling after the engine has started in cold weather, increase the engine rpm from 1000 to 1200 rpm. This operation will warm up the engine more quickly. Maintaining an elevated low idle speed for extended periods will be easier with the installation of a hand throttle. Allow the white smoke to disperse before proceeding with normal operation.
- Operate the engine at low load until all systems reach operating temperature. Check the gauges during the warm-up period.

i05365826

## Starting the Engine

**Note:** Do not adjust the engine speed control during start-up. The electronic control module (ECM) will control the engine speed during start-up.

### Starting the Engine

- Disengage any equipment that is driven by the engine.
- Turn the keyswitch to the first position power on. Check that the low oil pressure lamp is on solid. If the lamp is on solid, the engine start sequence can continue. If the lamp is flashing, and engine oil change is required. Refer to this Operation and Maintenance Manual, “Engine Oil and Filter - Change” for more information.
- Turn the keyswitch to the RUN position. Leave the keyswitch in the RUN position until the warning light for the glow plugs is extinguished.

**Note:** During the key on, the indicator lamps will be illuminated for 2 seconds in order to check lamp operation. If any of the lamps do not illuminate, check the bulb. If the fault remains refer to Troubleshooting, “Indicator Lamp Circuit - Test”.

- When the warning light for the glow plugs is extinguished, turn the keyswitch to the START position in order to engage the electric starting motor and crank the engine.

**Note:** The operating period of the warning light for the glow plugs will change due to the temperature of the engine.

#### NOTICE

Do not engage the starting motor when flywheel is turning. Do not start the engine under load.

If the engine fails to start within 30 seconds, release the starter switch or button and wait two minutes to allow the starting motor to cool before attempting to start the engine again.

- Allow the keyswitch to return to the RUN position after the engine starts. Ensure that all warning lamps are off.
- Repeat step 2 through step 5 if the engine fails to start.
- After starting, the engine will be held at low speed. The time held at low speed will depend on ambient temperature and time since last run. The procedure is in order to allow the engine systems to stabilize.
- If the engine will not start, refer to Troubleshooting, “Engine Cranks but Does Not Start”

i08134367

## Starting with Jump Start Cables

(Do Not Use This Procedure in Hazardous Locations that have Explosive Atmospheres)

### WARNING

The connection of battery cables to a battery and the disconnection of battery cables from a battery may cause an explosion which may result in injury or death. The connection and the disconnection of other electrical equipment may also cause an explosion which may result in injury or death. The procedures for the connection and the disconnection of battery cables and other electrical equipment should only be performed in a nonexplosive atmosphere.

## WARNING

**Improper jump start cable connections can cause an explosion resulting in personal injury.**

**Prevent sparks near the batteries. Sparks could cause vapors to explode. Do not allow jump start cable ends to contact each other or the engine.**

**Note:** If possible, first diagnose the reason for the starting failure. Refer to Troubleshooting, “Engine Will Not Crank and Engine Cranks But Will Not Start” for further information. Make any necessary repairs. If the engine will not start only due to the condition of the battery, either charge the battery, or start the engine by using another battery with jump-start cables. The condition of the battery can be rechecked after the engine has been switched OFF.

### NOTICE

Never attempt to start an engine from an external power source such as electric welding equipment, which has a voltage that is unsuitable for engine starting and will damage the electrical system.

For 904D-E28T industrial engines, use a 12 VDC battery source to start the engine.

For 904D-E36TA industrial engines, ensure that a 12 VDC or 24 VDC battery source is used to start the engine.

### NOTICE

Using a battery source with the same voltage as the electric starting motor. Use ONLY equal voltage for jump starting. The use of higher voltage will damage the electrical system.

Do not reverse the battery cables. The alternator can be damaged. Attach ground cable last and remove first.

Turn all electrical accessories OFF before attaching the jump start cables.

Ensure that the main power switch is in the OFF position before attaching the jump start cables to the engine being started.

1. Turn the start switch on the stalled engine to the OFF position. Turn off all the engines accessories.
2. Connect one positive end of the jump-start cable to the positive cable terminal of the discharged battery. Connect the other positive end of the jump-start cable to the positive cable terminal of the electrical source.

3. Connect one negative end of the jump-start cable to the negative cable terminal of the electrical source. Connect the other negative end of the jump-start cable to the engine block or to the chassis ground. This procedure helps to prevent potential sparks from igniting the combustible gases that are produced by some batteries.

**Note:** The engine ECM must be powered before the starting motor is operated or damage can occur.

4. Start the engine in the normal operating procedure. Refer to this Operation and Maintenance Manual, “Starting the Engine”.
5. Immediately after the engine is started, disconnect the jump-start cables in reverse order.

After jump starting, the alternator may not be able to recharge fully batteries that are severely discharged. The batteries must be replaced or charged to the proper voltage with a battery charger after the engine is stopped. Many batteries which are considered unusable are still rechargeable. Refer to Operation and Maintenance Manual, “Battery - Replace” and Testing and Adjusting Manual, “Battery - Test”.

i06721570

## After Starting Engine

After starting, the engine will be held at low speed. The time held at low speed will depend on ambient temperature and time since last run. The procedure is to allow the engine systems to stabilize.

**Note:** In ambient temperatures from 0°C to 60°C (32°F to 140°F), the warm-up time is approximately 3 minutes. In temperatures below 0°C (32°F), additional warm-up time may be required.

When the engine idles during warm-up, observe the following conditions:

Do not check the high-pressure fuel lines with the engine or the starting motor in operation. If you inspect the engine in operation, always use the proper inspection procedure to avoid a fluid penetration hazard. Refer to Operation and Maintenance Manual, “General hazard Information”.

- Check for any fluid or for any air leaks at idle rpm and at one-half full rpm (no load on the engine) before operating the engine under load.
- Allow the engine to idle for 3 to 5 minutes, or allow the engine to idle until the water temperature indicator begins to rise. Check all gauges during the warm-up period.

- Constant speed engines or constant power engines should be allowed to operate at low idle for 3 minutes before used at operational speed. If the low idle option is not available, then operate the engine at operational speed with no load for 2 minutes.

**Note:** Gauge readings should be observed and the data should be recorded frequently while the engine is operating. Comparing the data over time will help to determine normal readings for each gauge. Comparing data over time will also help detect abnormal operating developments. Significant changes in the readings should be investigated.

# Engine Operation

i04653132

## Engine Operation

i04690175

Proper operation and maintenance are key factors in obtaining the maximum life and economy of the engine. If the directions in the Operation and Maintenance Manual are followed, costs can be minimized and engine service life can be maximized.

The time that is needed for the engine to reach normal operating temperature can be less than the time taken for a walk-around inspection.

The engine can be operated at the rated rpm after the engine is started and after the engine reaches operating temperature. The engine will reach normal operating temperature sooner during a low engine speed (rpm) and during a low-power demand. This procedure is more effective than idling the engine at no load. The engine should reach operating temperature in a few minutes.

Avoid excess idling. Excessive idling causes carbon buildup, engine slobber and soot loading of the Diesel Particulate Filter (DPF). Excess idling can be harmful to the engine.

Gauge readings should be observed and the data should be recorded frequently while the engine is operating. Comparing the data over time will help to determine normal readings for each gauge. Comparing data over time will also help detect abnormal operating developments. Significant changes in the readings should be investigated.

## System Check

During normal engine operation the Electronic Control Module (ECM) will elevate the fuel pressure to the injectors. This check will be at scheduled intervals of approximately 100 hours depending on the duty cycle of the engine. The check will be carried out automatically without the need of any input from the operator.

During the time of elevated fuel pressure, the operator may notice a change in the tone of the engine. The ECM will operate the check at low idle for approximately 5 minutes.

## Diesel Particulate Filter Regeneration

### Regeneration

Regeneration is the removal of soot from the Diesel Particulate Filter (DPF). There are two different types of DPF that can be installed. The through flow DPF and the wall flow DPF. Engines with a power output of 56kW and above will have the wall flow DPF installed. Engines with a power output below 56kW have the option to use both types of DPF.

In table 4 titled **Indicator Operation** the operator will find information on the regeneration indicators. The table informs the operator why an indicator is illuminated and what action should be taken.

### Through Flow DPF

The through flow DPF uses passive regeneration in order to remove the soot from the DPF. Passive regeneration is a chemical reaction within the system. Normal operation of the engine creates enough heat for a chemical reaction in order to regenerate the DPF. The regeneration occurs automatically during normal engine operation.

This system uses an amount of active regeneration in order to ensure that soot cannot exit the DPF. The through flow DPF will not require manual cleaning.

For a typical view of the through flow DPF, refer to this Operation and Maintenance Manual, "Sensors and Electrical Components (Aftertreatment)"

### Wall Flow DPF

The wall flow DPF uses passive regeneration and active regeneration in order to remove the soot from the DPF. The ash is trapped within the DPF and must be removed by a manual cleaning process. Refer to Operation and Maintenance Manual, "Diesel Particulate Filter- Clean".

For a typical view of the wall flow DPF, refer to this Operation and Maintenance Manual, "Sensors and Electrical Components (Aftertreatment)"

## Regeneration Indicators

Five indicators can be affected by the DPF regeneration. these indicators are, Regeneration Active, DPF, Disable Regeneration, Amber, or Yellow Warning Indicator and Red Stop Indicator.



**Regeneration Active** – This indicator will illuminate during active regeneration. The indicator shows that elevated exhaust temperatures are possible. The indicator will be turned off when regeneration is complete.



**DPF** – This indicator provides a general indication of the soot load. The indicator is off when the soot load is normal.



**Disable Regeneration** – This indicator is illuminated whenever the disable switch is activated.

## Modes of Regeneration

- Automatic regeneration
- Manual regeneration

**Automatic regeneration** – Automatic regeneration will occur when the level of soot reaches the trigger point that is set in the ECM. The engine can operate normally during an automatic regeneration.

**Manual** – A manual regeneration is initiated by pressing the regeneration switch. A forced regeneration can only be performed after the soot load has illuminated the DPF indicator. A forced regeneration will only be required if the automatic regeneration has not been completed. This situation can be due to either the disable switch being operated or the duty cycle of the engine.

**Note:** In some applications the engine safety interlocks will need to be in place before a forced regeneration can occur.

## Regeneration Switch

**Note:** The regeneration switch is a three position switch. Some OEMs may use other means of activating a forced regeneration such as touch screen interfaces.



**Force Regeneration** – Press in the top of the switch for 2 seconds in order to begin regeneration.



**Disable Regeneration** – Press in the bottom of the switch for 2 seconds in order to disable regeneration.

**Note:** The MIDDLE position of the regeneration switch is the default position for automatic regeneration.

**Note:** You may return to normal operation at any point during a regeneration.

## Regeneration System Warning Indicators

Some applications may also have an audible warning installed.

Operation Section  
Diesel Particulate Filter Regeneration

Table 4

Indicator Operation					
During passive regeneration no indicator will be illuminated					
Aftertreatment Indicator	Aftertreatment Indicator State	Warning Indicator	Warning Indicator State	Description	Action Required
Regeneration Active indicator	On Solid	None	None	Regeneration is activated. The indicator will stay illuminated during regeneration.	None
-					
DPF Indicator	On Solid	None	None	The indicator provides a general indication of the soot load. The indicator is off when the soot load is normal.	A regeneration is required. In automatic mode the ECM will decide when to allow the active regeneration. If the DPF indicator stays illuminated allow a manual regeneration without interruption. An uninterrupted active regeneration will reset the DPF indicator.
-					
DPF Indicator	On Solid	Amber indicator	Flashing	The indicator indicates that the soot load has increased. The engine will derate.	A manual regeneration is required. Perform a manual regeneration, or a service regeneration will be required.
-					
DPF Indicator	On Solid	Amber indicator	Flashing	The flashing warning indicator and red stop indicator indicates that the engine has continued to be operated while a regeneration is required. The engine will be derated and the engine should be shut down immediately.	<b>Once the engine enters into shutdown mode, you must contact your Perkins distributor or your Perkins dealer.</b> Your dealer or distributor will need to perform a service level regeneration. <b>The DPF may need to be replaced.</b>
-	-	Red indicator (STOP)	On Solid		

**Note:** Amber or yellow warning indicator can be used as a diagnostic lamp. For more information refer to this Operation and Maintenance Manual, "Diagnostic Lamp".

## Regeneration Operation

Regeneration will require the following conditions:

### Automatic Regeneration

In order for an automatic regeneration to take place the engine must be at operating temperature.

Turning the keyswitch to the OFF position during a regeneration will stop the regeneration. An interrupted regeneration will not remove the soot from the DPF and will waste fuel.

### Wall Flow DPF Only

The engine Revs Per Minute (RPM) must be above 1200 RPM for the regeneration to start. Normal operation can continue. During an automatic regeneration the minimum idle speed will be controlled to 950 RPM.

### Manual Regeneration

The DPF indicator must be illuminated. Where applicable, safety interlock for your application must be engaged before a manual regeneration can occur, refer to your OEM for more information. No throttle inputs are required, the ECM will control the engine RPM. Press the force regeneration switch for 2 seconds. Do not operate the application during the manual regeneration.

### Service Regeneration

The electronic service tool will be required in order to perform a force regeneration. Contact your Perkins distributor or your Perkins dealer.

i07677865

## Fuel Conservation Practices

The efficiency of the engine can affect the fuel economy. Perkins design and technology in manufacturing provides maximum fuel efficiency in all applications. Follow the recommended procedures to attain optimum performance for the life of the engine.

- Avoid spilling fuel.

Fuel expands when it is warmed up. The fuel may overflow from the fuel tank. Inspect fuel lines for leaks. Repair the fuel lines, as needed.

- Be aware of the properties of different fuels. Use only the recommended fuels. Refer to the Operations and Maintenance Manual, "Fuel Recommendations" for further information.
- Avoid unnecessary idling.

Shut off the engine rather than allowing the engine to idle for long periods of time.

- Observe the service indicator frequently. Keep the air cleaner elements clean.
- Ensure that the turbocharger is operating correctly. For more information refer to this Operation and Maintenance Manual, "Turbocharger - Inspect"
- Maintain a good electrical system.

One faulty battery cell will overwork the alternator. This fault will consume excess power and excess fuel.

- The belt should be in good condition. Refer to the Systems Operation, Testing and Adjusting, "V-Belt Test" for further information.
- Ensure that all the connections of the hoses are tight. The connections should not leak.
- Ensure that the driven equipment is in good working order.

- Cold engines consume excess fuel. Utilize heat from the jacket water system and the exhaust system, when possible. Keep cooling system components clean and keep cooling system components in good repair. Never operate the engine without water temperature regulators. All these items will help maintain operating temperatures.

## Cold Weather Operation

i06024580

### Cold Weather Operation

Perkins Diesel Engines can operate effectively in cold weather. During cold weather, the starting and the operation of the diesel engine is dependent on the following items:

- The type of fuel that is used
- The viscosity of the engine oil
- The operation of the glow plugs
- Optional Cold starting aid
- Battery condition

This section will cover the following information:

- Potential problems that are caused by cold-weather operation
- Suggest steps which can be taken in order to minimize starting problems and operating problems when the ambient air temperature is between 0° to -40 °C (32° to 40 °F).

The operation and maintenance of an engine in freezing temperatures is complex . This complexity is because of the following conditions:

- Weather conditions
- Engine applications

Recommendations from your Perkins dealer or your Perkins distributor are based on past proven practices. The information that is contained in this section provides guidelines for cold-weather operation.

### Hints for Cold Weather Operation

- If the engine will start, operate the engine until a minimum operating temperature of 80° C (176° F) is achieved. Achieving operating temperature will help prevent the intake valves and exhaust valves from sticking.
- The cooling system and the lubrication system for the engine do not lose heat immediately upon shutdown. This means that an engine can be shut down for a period and the engine can still have the ability to start readily.
- Install the correct specification of engine lubricant before the beginning of cold weather.

- Check all rubber parts (hoses, fan drive belts,) weekly.
- Check all electrical wiring and connections for any fraying or damaged insulation.
- Keep all batteries fully charged and warm.
- Fill the fuel tank at the end of each shift.
- Check the air cleaners and the air intake daily. Check the air intake more often when you operate in snow.
- Ensure that the glow plugs are in working order. Refer to Troubleshooting, "Glow Plug Starting Aid-Test".

#### WARNING

**Personal injury or property damage can result from alcohol or starting fluids.**

**Alcohol or starting fluids are highly flammable and toxic and if improperly stored could result in injury or property damage.**

---

#### WARNING

**Do not use aerosol types of starting aids such as ether. Such use could result in an explosion and personal injury.**

---

- For jump starting with cables in cold weather, refer to the Operation and Maintenance Manual, "Starting with Jump Start Cables." for instructions.

### Viscosity of the Engine Lubrication Oil

Correct engine oil viscosity is essential. Oil viscosity affects the amount of torque that is needed to crank the engine. Refer to this Operation and Maintenance Manual, "Fluid Recommendations" for the recommended viscosity of oil.

### Recommendations for the Coolant

Provide cooling system protection for the lowest expected outside temperature. Refer to this Operation and Maintenance Manual, "Fluid Recommendations" for the recommended coolant mixture.

In cold weather, check the coolant often for the correct glycol concentration in order to ensure adequate freeze protection.



## Engine Block Heaters

Engine block heaters (if equipped) heat the engine jacket water that surrounds the combustion chambers. This heat provides the following functions:

- Startability is improved.
- Warm up time is reduced.

An electric block heater can be activated once the engine is stopped. A block heater can be 110 V dc or 240 V dc. The output can be 750/1000W. Consult your Perkins distributor for more information.

## Idling the Engine

After starting the engine, the engine speed will be held at low speed. The time held at low speed will depend on ambient temperature and time since last run. The procedure is in order to allow the engine system to stabilize. When idling after the engine is started in cold weather, increase the engine rpm from 1000 to 1200 rpm. This idling will warm up the engine more quickly. Maintaining an elevated low idle speed for extended periods will be easier with the installation of a hand throttle. The engine should not be "raced" in order to speed up the warm-up process.

While the engine is idling, the application of a light load (parasitic load) will assist in achieving the minimum operating temperature. The minimum operating temperature is 80° C (176° F).

## Recommendations for Coolant Warm Up

Warm up an engine that has cooled below normal operating temperatures due to inactivity. This warm-up should be performed before the engine is returned to full operation. During operation in very cold temperature conditions, damage to engine valve mechanisms can result from engine operation for short intervals. This damage can happen if the engine is started and the engine is stopped many times without being operated in order to warm up completely.

When the engine is operated below normal operating temperatures, fuel and oil are not burned completely in the combustion chamber. This fuel and oil causes soft carbon deposits to form on the valve stems. Generally, the deposits do not cause problems and the deposits are burned off during operation at normal engine operating temperatures.

When starting and stopping an engine many times without being operated in order to warm up completely, the carbon deposits become thicker. This starting and stopping can cause the following problems:

- Free operation of the valves is prevented.

- Valves become stuck.
- Pushrods may become bent.
- Other damage to valve train components can result.

For this reason, when the engine is started, the engine must be operated until the coolant temperature is 80° C (176° F) minimum. Carbon deposits on the valve stems will be kept at a minimum and the free operation of the valves and the valve components will be maintained.

The engine must be thoroughly warmed in order to keep other engine parts in better condition. The service life of the engine will be generally extended. Lubrication will be improved. There will be less acid and less sludge in the oil. This condition will provide longer service life for the engine bearings, the piston rings, and other parts. However, limit unnecessary idle time to 10 minutes in order to reduce wear and unnecessary fuel consumption.

## The Water Temperature Regulator and Insulated Heater Lines

The engine is equipped with a water temperature regulator. When the engine coolant is below the correct operating temperature, jacket water circulates through the engine cylinder block and into the engine cylinder head. The coolant then returns to the cylinder block via an internal passage that bypasses the valve of the coolant temperature regulator. This return ensures that coolant flows around the engine under cold operating conditions. The water temperature regulator begins to open when the engine jacket water has reached the correct minimum operating temperature. As the jacket water coolant temperature rises above the minimum operating temperature, the water temperature regulator opens further allowing more coolant through the radiator to dissipate excess heat.

The progressive opening of the water temperature regulator operates the progressive closing of the bypass passage between the cylinder block and head. This action ensures maximum coolant flow to the radiator in order to achieve maximum heat dissipation.

**Note:** Do not restrict the air flow. Restriction of the air flow can damage the fuel system. Perkins discourages the use of all air flow restriction devices such as radiator shutters. Restriction of the air flow can result in the following: high exhaust temperatures, power loss, excessive fan usage and reduction in fuel economy.

A cab heater is beneficial in very cold weather. The feed from the engine and the return lines from the cab should be insulated in order to reduce heat loss to the outside air.

## Recommendation for Crankcase Breather Protection

Crankcase ventilation gases can contain a large quantity of water vapor. This water vapor can freeze in cold ambient conditions and can plug or damage the crankcase ventilation system.

The breather heater or other breather thermal protection is important and any OEM equipment must be operational to prevent the risk of breather freezing for operation below  $-5^{\circ}\text{C}$  ( $23^{\circ}\text{F}$ ).

i07818744

## Fuel and the Effect from Cold Weather

**Note:** Only use grades of fuel that are recommended by Perkins. Refer to this Operation and Maintenance Manual, “Fluid Recommendations”.

Properties of the diesel fuel can have a significant effect on the engine cold start capability. It is critical that the low temperature properties of diesel fuel are acceptable for the minimum ambient temperature the engine is expected to see in operation.

Following properties are used to define fuels low temperature capability:

- Cloud point
- Pour point
- Cold Filter Plugging Point (CFPP)

The cloud point of the fuel is the temperature at which waxes naturally found in the diesel fuel begin to form crystals. The cloud point of the fuel must be below lowest ambient temperature to prevent filters from plugging.

Pour point is the last temperature before the fuel flow stops and waxing of the fuel will start.

Cold Filter Plugging Point (CFPP) is a temperature at which a particular fuel will pass through a standardized filtration device. This CFPP gives an estimate of the lower operability temperature of fuel

Be aware of these properties when diesel fuel is purchased. Consider the average ambient air temperature for the engines application. Engines that are fueled in one climate may not operate well if the engines are shipped to colder climate. Problems can result due to changes in temperature.

Before troubleshooting for low power or for poor performance in the winter, check the fuel for waxing

The following components can provide a means of minimizing fuel waxing problems in cold weather:

- Fuel heaters, which may be an OEM option
- Fuel line insulation, which may be an OEM option

Winter and arctic grades of diesel fuel are available in the countries and territories with severe winters. For more information refer to the Operation and Maintenance Manual, “Fuel For Cold-Weather Operation”

Another important fuel property which can affect cold start and operation of diesel engine is Cetane number. Detail and requirements of this property are given in this Operation and Maintenance Manual, “Fluid Recommendations”.

i02323237

## Fuel Related Components in Cold Weather

### Fuel Tanks

Condensation can form in partially filled fuel tanks. Top off the fuel tanks after you operate the engine.

Fuel tanks should contain some provision for draining water and sediment from the bottom of the tanks.

Some fuel tanks use supply pipes that allow water and sediment to settle below the end of the fuel supply pipe.

Some fuel tanks use supply lines that take fuel directly from the bottom of the tank. If the engine is equipped with this system, regular maintenance of the fuel system filter is important.

Drain the water and sediment from any fuel storage tank at the following intervals: weekly, service intervals and refueling of the fuel tank. This will help prevent water and/or sediment from being pumped from the fuel storage tank and into the engine fuel tank.

### Fuel Filters

A primary fuel filter is installed between the fuel tank and the engine fuel inlet. After you change the fuel filter, always prime the fuel system in order to remove air bubbles from the fuel system. Refer to the Operation and Maintenance Manual in the Maintenance Section for more information on priming the fuel system.

The location of a primary fuel filter is important in cold weather operation. The primary fuel filter and the fuel supply line are the most common components that are affected by cold fuel.

## Fuel Heaters

**Note:** The OEM may equip the application with fuel heaters. If this is the case, the temperature of the fuel must not exceed 73 °C (163 °F) at the fuel transfer pump.

For more information about fuel heaters (if equipped), refer to the OEM information.

## Engine Stopping

i05784249

i04535875

### Stopping the Engine

---

#### NOTICE

Stopping the engine immediately after it has been working under load, can result in overheating and accelerated wear of the engine components.

Avoid accelerating the engine prior to shutting it down.

Avoiding hot engine shutdowns will maximize turbo-charger shaft and bearing life.

---

**Note:** Individual applications will have different control systems. Ensure that the shutoff procedures are understood. Use the following general guidelines in order to stop the engine.

1. Remove the load from the engine. Reduce the engine speed (rpm) to low idle. Allow the engine to idle for 5 minutes in order to cool the engine.
2. Stop the engine after the cool down period according to the shutoff system on the engine and turn the ignition key switch to the OFF position. If necessary, refer to the instructions that are provided by the OEM.
3. Wait 60 seconds before the battery disconnect switch is turned off. The engine ECM required power after the keyswitch is turned off.

i07764840

### Emergency Stopping

---

#### NOTICE

Emergency shutoff controls are for EMERGENCY use ONLY. DO NOT use emergency shutoff devices or controls for normal stopping procedure.

The Original Equipment Manufacturer (OEM) may have equipped the application with an emergency stop button. For more information about the emergency stop button, refer to the OEM information.

Ensure that any components for the external system that support the engine operation are secured after the engine is stopped.

### After Stopping Engine

**Note:** Before you check the engine oil, do not operate the engine for at least 10 minutes. This period will allow the engine oil to return to the oil pan.

#### WARNING

**Contact with high pressure fuel may cause fluid penetration and burn hazards. High pressure fuel spray may cause a fire hazard. Failure to follow these inspection, maintenance and service instructions may cause personal injury or death.**

---

- After the engine has stopped, you must wait for 10 minutes in order to allow the fuel pressure to be purged from the high-pressure fuel lines before any service or repair is performed on the engine fuel lines. The 10 minute wait will also allow static charge to dissipate from the low-pressure fuel system. If necessary, perform minor adjustments. Repair any leaks from the low-pressure fuel system and from the cooling, lubrication, or air systems. Replace any high-pressure fuel line that has leaked. Refer to Disassembly and assembly Manual, "Fuel Injection Lines - Install".
- Check the crankcase oil level. Maintain the oil level between the "MIN" mark and the "MAX" mark on the engine oil level gauge.
- If the engine is equipped with a service hour meter, note the reading. Perform the maintenance that is in the Operation and Maintenance Manual, "Maintenance Interval Schedule".
- Fill the fuel tank, in order to help prevent accumulation of moisture in the fuel. Do not overfill the fuel tank.

---

#### NOTICE

Only use antifreeze/coolant mixtures recommended in this Operation and Maintenance Manual, "Refill Capacities and Recommendations" topic or in this Operation and Maintenance Manual, "Fluid Recommendations" topic. Failure to do so can cause engine damage.

---

 **WARNING**

**Pressurized System: Hot coolant can cause serious burns. To open the cooling system filler cap, stop the engine and wait until the cooling system components are cool. Loosen the cooling system pressure cap slowly in order to relieve the pressure.**

---

- Allow the engine to cool. Check the coolant level.
- Check the coolant for correct antifreeze protection and the correct corrosion protection. Add the correct coolant/water mixture, if necessary.
- Perform all required periodic maintenance on all driven equipment. This maintenance is outlined in the instructions from the OEM.

# Maintenance Section

## Refill Capacities

i04794766

### Refill Capacities

### Lubrication System

The refill capacities for the engine crankcase reflect the approximate capacity of the crankcase or sump plus standard oil filters. Auxiliary oil filter systems will require additional oil. Refer to the OEM specifications for the capacity of the auxiliary oil filter. Refer to the Operation and Maintenance Manual, "Maintenance Section" for more information on Lubricant Specifications.

Table 5

Engine Refill Capacities		
Compartment or System	Minimum	Maximum
Crankcase Oil Sump <sup>(1)</sup>	6 L (1.6 US gal)	8.5 L (2.2 US gal)

<sup>(1)</sup> These values are the approximate capacities for the crankcase oil sump (aluminum) which includes the standard factory installed oil filters. Engines with auxiliary oil filters will require additional oil. Refer to the OEM specifications for the capacity of the auxiliary oil filter. The design of the oil pan can change the oil capacity of the oil pan.

### Cooling System

Refer to the OEM specifications for the External System capacity. This capacity information will be needed in order to determine the amount of coolant/antifreeze that is required for the Total Cooling System.

Table 6

Engine Refill Capacities	
Compartment or System	Liters
Engine Only	6 L (1.6 US gal)
External System Per OEM <sup>(1)</sup>	

(continued)

(Table 6, contd)

<sup>(1)</sup> The External System includes a radiator or an expansion tank with the following components: heat exchanger and piping. Refer to the OEM specifications. Enter the value for the capacity of the External System in this row.

i05344256

## Fluid Recommendations

### General Lubricant Information

Because of government regulations regarding the certification of exhaust emissions from the engine, the lubricant recommendations must be followed.

- API\_\_\_\_\_American Petroleum Institute
- SAE\_\_\_\_\_Society Of Automotive Engineers Inc.
- ACEA\_\_\_\_\_Association des Constructeurs European Automobiles.
- ECF-3\_\_\_\_\_Engine Crankcase Fluid

### Licensing

The Engine Oil Licensing and Certification System by the American Petroleum Institute (API) and the Association des Constructeurs European Automobiles (ACRA) is recognized by Perkins. For detailed information about this system, see the latest edition of the "API publication No. 1509". Engine oils that bear the API symbol are authorized by API.

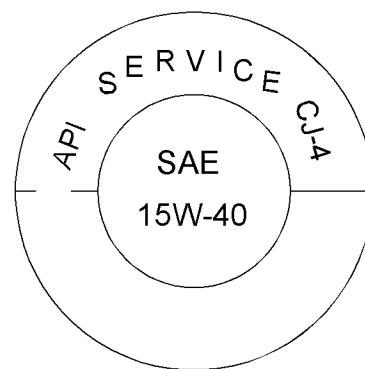

Illustration 41

Typical API symbol

g01987816

## Terminology

Certain abbreviations follow the nomenclature of "SAE J754". Some classifications follow "SAE J183" abbreviations, and some classifications follow the "EMA Recommended Guideline on Diesel Engine Oil". In addition to Perkins definitions, there are other definitions that will be of assistance in purchasing lubricants. Recommended oil viscosities can be found in this publication, "Fluid Recommendations/ Engine Oil" topic (Maintenance Section).

## Engine Oil

### Commercial Oils

#### NOTICE

**Perkins require the use of the following specification of engine oil. Failure to use the appropriate specification of engine oil will reduce the life of your engine. Failure to use the appropriate specification of engine oil will also reduce the life of your aftertreatment system.**

Table 7

Classifications for the 854 Industrial Engine
Oil Specification
API CJ-4 ACEA E9 ECF-3

API CJ-4 and ACEA E9 oil categories have the following chemical limits:

- 0.1 percent maximum sulfated ash
- 0.12 percent maximum phosphorous
- 0.4 percent maximum sulfur

The chemical limits were developed in order to maintain the expected life of the engine aftertreatment system. The performance of the engine aftertreatment system can be adversely affected if oil that is not specified in table 7 is used.

The life of your Aftertreatment system is defined by the accumulation of ash on the surface of the filter. Ash is the inert part of the particulate matter. The system is designed in order to collect this particulate matter. There is a small percentage of particulate matter that is left behind as the soot is burnt. This matter will eventually block the filter, causing loss of performance and increased fuel consumption. Most of the ash comes from the engine oil which is gradually consumed during normal operation. This ash is passes through the exhaust. To meet the designed life of the product, the use of the appropriate engine oil is essential. The oil specification that is listed in table 7 has low ash content.

**Maintenance intervals for engines that use biodiesel** – The oil change interval can be adversely affected by the use of biodiesel. Use oil analysis in order to monitor the condition of the engine oil. Use oil analysis also in order to determine the oil change interval that is optimum.

**Note: These engine oils are not approved by Perkins and these engine oils must not be used: CC, CD, CD-2, CF-4, CG-4, CH-4 and CI-4.**

### Lubricant Viscosity Recommendations for Direct Injection (DI) Diesel Engines

The correct SAE viscosity grade of oil is determined by the minimum ambient temperature during cold engine start-up, and the maximum ambient temperature during engine operation.

Refer to illustration 42 (minimum temperature) in order to determine the required oil viscosity for starting a cold engine.

Refer to illustration 42 (maximum temperature) in order to select the oil viscosity for engine operation at the highest ambient temperature that is anticipated.

Generally, use the highest oil viscosity that is available to meet the requirement for the temperature at start-up.

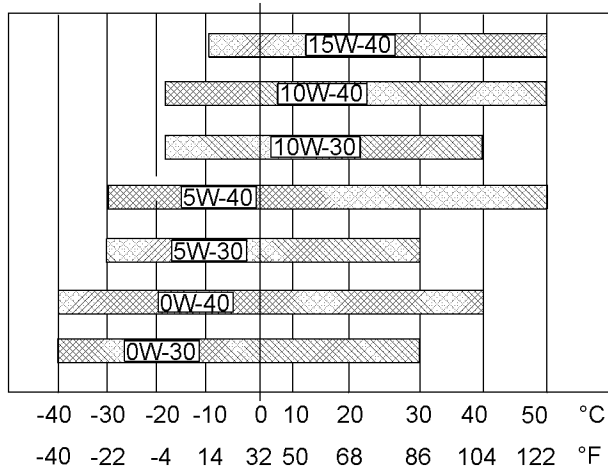

Illustration 42

g03363756

### Lubricant Viscosities

Supplemental heat is recommended for cold soaked starts below the minimum ambient temperature. Supplemental heat may be required for cold soaked starts that are above the minimum temperature that is stated, depending on the parasitic load and other factors. Cold soaked starts occur when the engine has not been operated for a period of time. This interval will allow the oil to become more viscous due to cooler ambient temperatures.

### Aftermarket Oil Additives

Perkins does not recommend the use of aftermarket additives in oil. It is not necessary to use aftermarket additives in order to achieve the engines maximum service life or rated performance. Fully formulated, finished oils consist of base oils and of commercial additive packages. These additive packages are blended into the base oils at precise percentages in order to help provide finished oils with performance characteristics that meet industry standards.

There are no industry standard tests that evaluate the performance or the compatibility of aftermarket additives in finished oil. Aftermarket additives may not be compatible with the finished oils additive package, which could lower the performance of the finished oil. The aftermarket additive could fail to mix with the finished oil. This failure could produce sludge in the crankcase. Perkins discourages the use of aftermarket additives in finished oils.

To achieve the best performance from a Perkins engine, conform to the following guidelines:

- See the appropriate "Lubricant Viscosities". Refer to the illustration 42 in order to find the correct oil viscosity grade for your engine.

- At the specified interval, service the engine. Use new oil and install a new oil filter.
- Perform maintenance at the intervals that are specified in the Operation and Maintenance Manual, "Maintenance Interval Schedule".

### Oil analysis

Some engines may be equipped with an oil sampling valve. If oil analysis is required, the oil sampling valve is used to obtain samples of the engine oil. The oil analysis will complement the preventive maintenance program.

The oil analysis is a diagnostic tool that is used to determine oil performance and component wear rates. Contamination can be identified and measured by using oil analysis. The oil analysis includes the following tests:

- The Wear Rate Analysis monitors the wear of the engines metals. The amount of wear metal and type of wear metal that is in the oil is analyzed. The increase in the rate of engine wear metal in the oil is as important as the quantity of engine wear metal in the oil.
- Tests are conducted in order to detect contamination of the oil by water, glycol, or fuel.
- The Oil Condition Analysis determines the loss of the oils lubricating properties. An infrared analysis is used to compare the properties of new oil to the properties of the used oil sample. This analysis allows technicians to determine the amount of deterioration of the oil during use. This analysis also allows technicians to verify the performance of the oil according to the specification during the entire oil change interval.

i06704125

## Fluid Recommendations

### General Coolant Information

#### NOTICE

Never add coolant to an overheated engine. Engine damage could result. Allow the engine to cool first.

#### NOTICE

If the engine is to be stored in, or shipped to an area with below freezing temperatures, the cooling system must be either protected to the lowest outside temperature or drained completely to prevent damage.



**NOTICE**

Frequently check the specific gravity of the coolant for proper freeze protection or for anti-boil protection.

Clean the cooling system for the following reasons:

- Contamination of the cooling system
- Overheating of the engine
- Foaming of the coolant

**NOTICE**

Never operate an engine without water temperature regulators in the cooling system. Water temperature regulators help to maintain the engine coolant at the proper operating temperature. Cooling system problems can develop without water temperature regulators.

Many engine failures are related to the cooling system. The following problems are related to cooling system failures: Overheating, leakage of the water pump and plugged radiators or heat exchangers.

These failures can be avoided with correct cooling system maintenance. Cooling system maintenance is as important as maintenance of the fuel system and the lubrication system. Quality of the coolant is as important as the quality of the fuel and the lubricating oil.

Coolant is normally composed of three elements: Water, additives, and glycol.

**Water**

Water is used in the cooling system to transfer heat.

**Distilled water or deionized water is recommended for use in engine cooling systems.**

DO NOT use the following types of water in cooling systems: Hard water, softened water that has been conditioned with salt and sea water.

If distilled water or deionized water is not available, use water with the properties that are listed in Table 8.

Table 8

Acceptable Water	
Property	Maximum Limit
Chloride (Cl)	40 mg/L
Sulfate (SO <sub>4</sub> )	100 mg/L
Total Hardness	170 mg/L
Total Solids	340 mg/L
Acidity	pH of 5.5 to 9.0

For a water analysis, consult one of the following sources:

- Local water utility company
- Agricultural agent
- Independent laboratory

**Additives**

Additives help to protect the metal surfaces of the cooling system. A lack of coolant additives or insufficient amounts of additives enable the following conditions to occur:

- Corrosion
- Formation of mineral deposits
- Rust
- Scale
- Foaming of the coolant

Many additives are depleted during engine operation. These additives must be replaced periodically.

Additives must be added at the correct concentration. Over concentration of additives can cause the inhibitors to drop out-of-solution. The deposits can enable the following problems to occur:

- Formation of gel compounds
- Reduction of heat transfer
- Leakage of the water pump seal
- Plugging of radiators, coolers, and small passages

**Glycol**

Glycol in the coolant helps to provide protection against the following conditions:

- Boiling
- Freezing
- Cavitation of the water pump

For optimum performance, Perkins recommends a 1:1 mixture of a water/glycol solution.

**Note:** Use a mixture that will provide protection against the lowest ambient temperature.

**Note:** 100 percent pure glycol will freeze at a temperature of -13 °C (8.6 °F).

Maintenance Section  
Fluid Recommendations

Most conventional antifreezes use ethylene glycol. Propylene glycol may also be used. In a 1:1 mixture with water, ethylene and propylene glycol provide similar protection against freezing and boiling. Refer to Table 9 and refer to table 10 .

Table 9

Ethylene Glycol	
Concentration	Freeze Protection
50 Percent	-36 °C (-33 °F)
60 Percent	-51 °C (-60 °F)

---

**NOTICE**

Do not use propylene glycol in concentrations that exceed 50 percent glycol because of the reduced heat transfer capability of propylene glycol. Use ethylene glycol in conditions that require additional protection against boiling or freezing.

Table 10

Propylene Glycol	
Concentration	Freeze Protection
50 Percent	-29 °C (-20 °F)

To check the concentration of glycol in the coolant, measure the specific gravity of the coolant.

### Coolant Recommendations

- ELC \_\_\_\_\_ Extended Life Coolant
- SCA \_\_\_\_\_ Supplement Coolant Additive
- ASTM \_\_\_\_\_ American Society for Testing and Materials

The following two coolants are used in Perkins diesel engines:

**Preferred** – Perkins ELC

**Acceptable** – A commercial heavy-duty antifreeze that meets “ASTM D6210” specifications

---

**NOTICE**

**The 854 industrial engines must be operated with a 1:1 mixture of water and glycol. This concentration allows the NOx reduction system to operate correctly at high ambient temperatures.**

---

**NOTICE**

Do not use a commercial coolant/antifreeze that only meets the ASTM D3306 specification. This type of coolant/antifreeze is made for light automotive applications.

Perkins recommends a 1:1 mixture of water and glycol. This mixture of water and glycol will provide optimum heavy-duty performance as an antifreeze. This ratio may be increased to 1:2 water to glycol if extra freezing protection is required.

A mixture of SCA inhibitor and water is acceptable but will not give the same level of corrosion, boiling and, freezing protection as ELC. Perkins recommends a 6 percent to 8 percent concentration of SCA in those cooling systems. Distilled water or deionized water is preferred. Water which has the recommended properties may be used.

Table 11

Coolant Service Life	
Coolant Type	Service Life <sup>(1)</sup>
Perkins ELC	6,000 Service Hours or Three Years
Commercial Heavy-Duty Antifreeze that meets “ASTM D6210”	3000 Service Hours or Two Year
Commercial SCA inhibitor and Water	3000 Service Hours or One Year

<sup>(1)</sup> Use the interval that occurs first. The cooling system must also be flushed out at this time.

### ELC

Perkins provides ELC for use in the following applications:

- Heavy-duty spark ignited gas engines
- Heavy-duty diesel engines
- Automotive applications

The anti-corrosion package for ELC is different from the anti-corrosion package for other coolants. ELC is an ethylene glycol base coolant. However, ELC contains organic corrosion inhibitors and antifoam agents with low amounts of nitrite. Perkins ELC has been formulated with the correct amount of these additives to provide superior corrosion protection for all metals in engine cooling systems.

ELC is available in a premixed cooling solution with distilled water. ELC is a 1:1 mixture. The Premixed ELC provides freeze protection to -36 °C (-33 °F). The Premixed ELC is recommended for the initial fill of the cooling system. The Premixed ELC is also recommended for topping off the cooling system.

Containers of several sizes are available. Consult your Perkins distributor for the part numbers.

## ELC Cooling System Maintenance

### Correct additions to the Extended Life Coolant

---

#### NOTICE

Use only Perkins products for pre-mixed or concentrated coolants.

Mixing Extended Life Coolant with other products reduces the Extended Life Coolant service life. Failure to follow the recommendations can reduce cooling system components life unless appropriate corrective action is performed.

---

To maintain the correct balance between the antifreeze and the additives, you must maintain the recommended concentration of ELC. Lowering the proportion of antifreeze lowers the proportion of additive. This will lower the ability of the coolant to protect the system from pitting, from cavitation, from erosion, and from deposits.

---

#### NOTICE

Do not use a conventional coolant to top-off a cooling system that is filled with Extended Life Coolant (ELC).

Do not use standard supplemental coolant additive (SCA).

When using Perkins ELC, do not use standard SCA's or SCA filters.

### ELC Cooling System Cleaning

**Note:** If the cooling system is already using ELC, cleaning agents are not required to be used at the specified coolant change interval. Cleaning agents are only required if the system has been contaminated by the addition of some other type of coolant or by cooling system damage.

Clean water is the only cleaning agent that is required when ELC is drained from the cooling system.

Before the cooling system is filled, the heater control (if equipped) must be set to the HOT position. Refer to the OEM to set the heater control. After the cooling system is drained and the cooling system is refilled, operate the engine until the coolant level reaches the normal operating temperature and until the coolant level stabilizes. As needed, add the coolant mixture to fill the system to the specified level.

### Changing to Perkins ELC

To change from heavy-duty antifreeze to the Perkins ELC, perform the following steps:

---

#### NOTICE

Care must be taken to ensure that all fluids are contained during performance of inspection, maintenance, testing, adjusting and the repair of the product. Be prepared to collect the fluid with suitable containers before opening any compartment or disassembling any component containing fluids.

Dispose of all fluids according to local regulations and mandates.

- 
1. Drain the coolant into a suitable container.
  2. Dispose of the coolant according to local regulations.
  3. Fill the cooling system with a 33 percent solution of Perkins ELC and operate the engine, ensure that the thermostat opens. Stop the engine and allow the engine to cool. Drain the coolant.

**Note:** Use distilled or deionized water in the solution.

4. Again, fill the cooling system with a 33 percent solution of Perkins ELC and operate the engine ensure that the thermostat opens. Stop the engine and allow to cool.
5. Drain the cooling system.

---

#### NOTICE

Incorrect or incomplete flushing of the cooling system can result in damage to copper and other metal components.

- 
6. Fill the cooling system with the Perkins Premixed ELC. Operate the engine. Ensure that all coolant valves open then stop the engine. When cool check the coolant level.

### ELC Cooling System Contamination

---

#### NOTICE

Mixing ELC with other products reduces the effectiveness of the ELC and shortens the ELC service life. Use only Perkins Products for premixed or concentrate coolants. Failure to follow these recommendations can result in shortened cooling system component life.

---

ELC cooling systems can withstand contamination to a maximum of 10 percent of conventional heavy-duty antifreeze or SCA. If the contamination exceeds 10 percent of the total system capacity, perform ONE of the following procedures:

Maintenance Section  
Fluid Recommendations

- Drain the cooling system into a suitable container. Dispose of the coolant according to local regulations. Flush the system with clean water. Fill the system with the Perkins ELC.
- Drain a portion of the cooling system into a suitable container according to local regulations. Then, fill the cooling system with premixed ELC. This procedure should lower the contamination to less than 10 percent.
- Maintain the system as a conventional Heavy-Duty Coolant. Treat the system with an SCA. Change the coolant at the interval that is recommended for the conventional Heavy-Duty Coolant.

### Commercial Heavy-Duty Antifreeze and SCA

#### NOTICE

Commercial Heavy-Duty Coolant which contains Amine as part of the corrosion protection system must not be used.

#### NOTICE

Never operate an engine without water temperature regulators in the cooling system. Water temperature regulators help to maintain the engine coolant at the correct operating temperature. Cooling system problems can develop without water temperature regulators.

Check the antifreeze (glycol concentration) to ensure adequate protection against boiling or freezing. Perkins recommends the use of a refractometer for checking the glycol concentration. A hydrometer should not be used.

Perkins engine cooling systems should be tested at 500-hour intervals for the concentration of SCA.

Additions of SCA are based on the results of the test. An SCA that is liquid may be needed at 500-hour intervals.

### Adding the SCA to Heavy-Duty Coolant at the Initial Fill

Use the equation that is in Table 12 to determine the amount of SCA that is required when the cooling system is initially filled.

Table 12

Equation For Adding The SCA To The Heavy-Duty Coolant At The Initial Fill
$V \times 0.045 = X$
V is the total volume of the cooling system.
X is the amount of SCA that is required.

Table 13 is an example for using the equation that is in Table 12 .

Table 13

Example Of The Equation For Adding The SCA To The Heavy-Duty Coolant At The Initial Fill		
Total Volume of the Cooling System (V)	Multiplication Factor	Amount of SCA that is Required (X)
15 L (4 US gal)	$\times 0.045$	0.7 L (24 oz)

### Adding The SCA to The Heavy-Duty Coolant For Maintenance

Heavy-duty antifreeze of all types REQUIRE periodic additions of an SCA.

Test the antifreeze periodically for the concentration of SCA. For the interval, refer to the Operation and Maintenance Manual, "Maintenance Interval Schedule" (Maintenance Section). Cooling System Supplemental Coolant Additive (SCA) Test/Add.

Additions of SCA are based on the results of the test. The size of the cooling system determines the amount of SCA that is needed.

Use the equation that is in Table 14 to determine the amount of SCA that is required, if necessary:

Table 14

Equation For Adding The SCA To The Heavy-Duty Coolant For Maintenance
$V \times 0.014 = X$
V is the total volume of the cooling system.
X is the amount of SCA that is required.

Table 15 is an example for using the equation that is in Table 14 .

Table 15

Example Of The Equation For Adding The SCA To The Heavy-Duty Coolant For Maintenance		
Total Volume of the Cooling System (V)	Multiplication Factor	Amount of SCA that is Required (X)
15 L (4 US gal)	$\times 0.014$	0.2 L (7 oz)

### Cleaning the System of Heavy-Duty Antifreeze

- Clean the cooling system after used coolant is drained or before the cooling system is filled with new coolant.

- Clean the cooling system whenever the coolant is contaminated or whenever the coolant is foaming.

i06707156

## Fluid Recommendations (Fuel Specification)

### • Glossary

- ISO \_\_\_\_\_International Standards Organization
- ASTM \_\_\_\_\_American Society for Testing and Materials
- HFRR \_\_\_\_\_High Frequency Reciprocating Rig for Lubricity testing of diesel fuels
- FAME \_\_\_\_\_Fatty Acid Methyl Esters
- CFR \_\_\_\_\_Co-ordinating Fuel Research
- ULSD \_\_\_\_\_Ultra Low Sulfur Diesel
- RME \_\_\_\_\_Rape Methyl Ester
- SME \_\_\_\_\_Soy Methyl Ester
- EPA \_\_\_\_\_Environmental Protection Agency of the United States
- PPM \_\_\_\_\_Parts Per Million
- DPF \_\_\_\_\_Diesel Particulate Filter
- v/v \_\_\_\_\_(volume of solute)/(volume of solution)
- CFPP \_\_\_\_\_Cold Filter Plugging Point
- BTL \_\_\_\_\_Biomass to liquid
- GTL \_\_\_\_\_Gas to liquid
- CTL \_\_\_\_\_Coal to liquid
- HVO \_\_\_\_\_Hydrotreated Vegetable Oil

## General Information

---

### NOTICE

Every attempt is made to provide accurate, up-to-date information. By use of this document you agree that Perkins Engines Company Limited is not responsible for errors or omissions.

---



---

### NOTICE

These recommendations are subject to change without notice. Contact your local Perkins distributor for the most up-to-date recommendations.

---

## Diesel Fuel Requirements

Perkins is not in a position to continuously evaluate and monitor all worldwide distillate diesel fuel specifications that are published by governments and technological societies.

The "Perkins Specification for Distillate Diesel Fuel" provides a known reliable baseline to judge the expected performance of distillate diesel fuels that are derived from conventional sources.

Satisfactory engine performance depends on the use of a good quality fuel. The use of a good quality fuel will give the following results: long engine life and acceptable exhaust emissions levels. The fuel must meet the minimum requirements that are stated in the table 16 .

---

### NOTICE

The footnotes are key part of the Perkins "Specification for Distillate Diesel Fuel" Table. Read ALL of the footnotes.

---

Maintenance Section  
Fuel Specification

Table 16

<b>"Perkins Specification for Distillate Diesel Fuel"</b>				
<b>Property</b>	<b>UNITS</b>	<b>Requirements</b>	<b>"ASTM"Test</b>	<b>"ISO/Other"Test</b>
Aromatics	%Volume	35% maximum	"D1319"	"ISO 3837"
Ash	%Weight	0.01% maximum	"D482"	"ISO 6245"
Carbon Residue on 10% Bottoms	%Weight	0.35% maximum	"D524"	"ISO 4262"
Cetane Number <sup>(1)</sup>	-	40 minimum	"D613 or D6890"	"ISO 5165"
Cloud Point	°C	The cloud point must not exceed the lowest expected ambient temperature.	"D2500"	"ISO 3015"
Copper Strip Corrosion	-	No. 3 maximum	"D130"	"ISO 2160"
Distillation	°C	10% at 238° C (460.4° F) maximum	"D86"	"ISO 3405"
		90% at 350° C (662° F) maximum		
Density at 15 °C (59 °F) <sup>(2)</sup>	kg/M <sup>3</sup>	800 minimum and 860 maximum	No equivalent test	"ISO 3675""ISO 12185"
Flash Point	°C	legal limit	"D93"	"ISO 2719"
Thermal Stability	-	Minimum of 80% reflectance after aging for 180 minutes at 150 °C (302 °F)	"D6468"	No equivalent test
Pour Point	°C	6 °C (42.8 °F) minimum below ambient temperature	"D97"	"ISO 3016"
Sulfur <sup>(3)</sup>	%mass	0.0015 % maximum	"D5453"	"ISO 20846"
Kinematic Viscosity <sup>(4)</sup>	MM <sup>2</sup> /S (cSt)	The viscosity of the fuel that is delivered to the fuel injection pump. 1.4 minimum and 4.5 maximum	"D445"	"ISO 3405"
Water and sediment	% weight	0.05% maximum	"D1796"	"ISO 3734"
Water	% weight	0.05% maximum	"D1744"	No equivalent test
Sediment	% weight	0.05% maximum	"D473"	"ISO 3735"
Gums and Resins <sup>(5)</sup>	mg/100mL	10 mg per 100 mL maximum	"D381"	"ISO 6246"
Lubricity corrected wear scar diameter at 60 °C (140 °F). <sup>(6)</sup>	mm	0.52 maximum	"D6079"	"ISO 12156-1"
Fuel Cleanliness <sup>(7)</sup>	-	"ISO 18/16/13"	"D7619"	"ISO 4406"
Trace Metals <sup>(8)</sup>	mg/mg	Max 1 or non-detectable	"D7111"	
Oxidation Stability	g/m <sup>3</sup>	Max 25	"D2274"	"ISO 12205"
	Hours <sup>(9)</sup>	Min 20		"EN 15751"

- (1) To insure minimum cetane number of 40 a distillate diesel fuel should have minimum cetane index of 44 when "ASTM D4737" test method is used. A fuel with a higher cetane number is recommended to operate at a higher altitude or in cold weather
- (2) Density range allowed includes summer and winter diesel fuel grades.
- (3) Ultra Low Sulfur Diesel Fuel with sulphur content less than 0.0015 percent 15 PPM (mg/kg) must be used. Use of diesel fuel with higher than 15 PPM sulphur limit in these engines will harm or permanently damage emissions control systems. Also, use of diesel fuel with higher than 15 PPM sulphur limit can shorten service interval.

(continued)

(Table 16, contd)

- (4) The values of the fuel viscosity are the values as the fuel is delivered to the fuel injection pumps. Fuel should also meet the minimum viscosity requirement and the fuel should meet the maximum viscosity requirements at 40 °C (104 °F) of either the “ASTM D445” test method or the “ISO 3104” test method. If a fuel with a low viscosity is used, cooling of the fuel may be required to maintain “1.4 cSt” or greater viscosity at the fuel injection pump. Fuels with a high viscosity might require fuel heaters to lower the viscosity to “1.4 cSt” at the fuel injection pump.
- (5) Follow the test conditions and procedures for gasoline (motor).
- (6) The lubricity of a fuel is a concern with low sulfur and ultra low sulfur fuel. To determine the lubricity of the fuel, use the “ISO 12156-1 or ASTM D6079 High Frequency Reciprocating Rig (HFRR)” test. If the lubricity of a fuel does not meet the minimum requirements, consult your fuel supplier. Do not treat the fuel without consulting the fuel supplier. Some additives are not compatible. These additives can cause problems in the fuel system.
- (7) Recommended cleanliness level for fuel as dispensed into machine or engine fuel tank is “ISO 18/16/13” or cleaner as per “ISO 4406”. Refer to the “Contamination Control Recommendations for Fuels”.
- (8) Examples of trace metals include but not limited to Cu, Fe, Mn, Na, P, Pb, Si, and Zn. Use of metal-based additives is not allowed.
- (9) Additional limit for fuel containing FAME. Fuel containing more than 2% v/v FAME must meet both tests.

Engines that are manufactured by Perkins are certified with the fuel that is prescribed by the United States Environmental Protection Agency. Engines that are manufactured by Perkins are certified with the fuel that is prescribed by the European Certification. Perkins does not certify diesel engines on any other fuel.

**Note:** The owner and the operator of the engine has the responsibility of using the fuel that is prescribed by the EPA and other appropriate regulatory agencies.

**NOTICE**

Operating with fuels that do not meet the Perkins recommendations can cause the following effects: Starting difficulty, reduced fuel filter service life, poor combustion, deposits in the fuel injectors, significantly reduce service life of the fuel system. Also, the creation of deposits in the combustion chamber and reduced service life of the engine.

**NOTICE**

The Perkins 854 series of diesel engine must be operated using Ultra Low Sulfur Diesel. The sulphur content of this fuel must be lower than 15 PPM. This fuel complies with the emissions regulations that are prescribed by the Environmental Protection Agency of the United States.

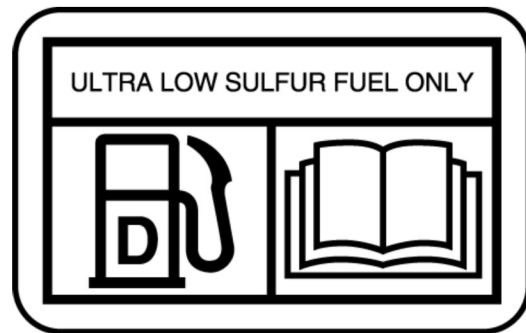

Illustration 43

g02157153

Illustration 43 is a representation of the label that will be installed next to the fuel filler cap on the fuel tank of the application.

The fuel specifications that are listed in the table 17 are released as acceptable to use on all 854 series of engine.

Table 17

Acceptable Fuel Specification for the 854 Series of Engines <sup>(1)</sup>	
Fuel Specification	Comments
EN590	European Automotive Diesel Fuel (DERV)
“ASTM D975 GRADE 1D S15”	“North American Light Distillate Diesel fuel with less than 15 PPM sulfur level”
“ASTM D975 GRADE 2D S15”	“North American Middle Distillate general-purpose Diesel fuel with less than 15 PPM sulfur level”
“JIS K2204”	“Japanese Diesel Fuel” Must meet the requirements that are stated in the section “Lubricity”.
“BS 2869: 2010 CLASS A2 or EU equivalent”	“EU Off-Road Diesel fuel. Acceptable from 2011 MUST have less than 10 PPM sulfur level”

<sup>(1)</sup> All the fuels must comply with the specification in the table for the Perkins Specification Distillate Diesel Fuel.

## Diesel Fuel Characteristics

### Cetane Number

Fuel that has a high cetane number will give a shorter ignition delay. A high cetane number will produce a better ignition quality. Cetane numbers are derived for fuels against proportions of cetane and heptamethylnonane in the standard CFR engine. Refer to "ISO 5165" for the test method.

Cetane numbers more than 45 are normally expected from current diesel fuel. However, a cetane number of 40 may be experienced in some territories. The United States of America is one of the territories that can have a low cetane value. A minimum cetane value of 40 is required during average starting conditions. A fuel with higher cetane number is recommended for operations at high altitudes or in cold-weather operations.

Fuel with a low cetane number can be the root cause of problems during a cold start.

### Viscosity

Viscosity is the property of a liquid of offering resistance to shear or flow. Viscosity decreases with increasing temperature. This decrease in viscosity follows a logarithmic relationship for normal fossil fuel. The common reference is to kinematic viscosity. Kinematic viscosity is the quotient of the dynamic viscosity that is divided by the density. The determination of kinematic viscosity is normally by readings from gravity flow viscometers at standard temperatures. Refer to "ISO 3104" for the test method.

The viscosity of the fuel is significant because fuel serves as a lubricant for the fuel system components. Fuel must have sufficient viscosity to lubricate the fuel system in both extremely cold temperatures and extremely hot temperatures. If the kinematic viscosity of the fuel is lower than "1.4 cSt" at the fuel injection pump, damage to the fuel injection pump can occur. This damage can be excessive scuffing and seizure. Low viscosity may lead to difficult hot restarting, stalling, and loss of performance. High viscosity may result in seizure of the pump.

Perkins recommends kinematic viscosities of 1.4 and 4.5 mm<sup>2</sup>/sec that is delivered to the fuel injection pump. If a fuel with a low viscosity is used, cooling of the fuel may be required to maintain 1.4 cSt or greater viscosity at the fuel injection pump. Fuels with a high viscosity might require fuel heaters to lower the viscosity to 4.5 cSt at the fuel injection pump.

### Density

Density is the mass of the fuel per unit volume at a specific temperature. This parameter has a direct influence on engine performance and a direct influence on emissions. This influence determines from a heat output given injected volume of fuel. This parameter is quoted in the following kg/m<sup>3</sup> at 15 °C (59 °F).

Perkins recommends a density of 841 kg/m<sup>3</sup> to obtain the correct power output. Lighter fuels are acceptable but these fuels will not produce the rated power.

### Sulfur

The level of sulfur is governed by emissions legislations. Regional regulation, national regulations, or international regulations can require a fuel with a specific sulfur limit. The sulfur content of the fuel and the fuel quality must comply with all existing local regulations for emissions.

Perkins 854 series diesel engines have been designed to operate only with ULSD. By using the test methods "ASTM D5453, or ISO 20846", the content of sulfur in ULSD fuel must be below 15 PPM (mg/kg) or 0.0015% mass.

---

#### NOTICE

Use of diesel fuel with higher than 15 PPM sulphur limit in these engines will harm or permanently damage emissions control systems and/or shorten service interval.

---

### Lubricity

Lubricity is the capability of the fuel to prevent pump wear. The fluids lubricity describes the ability of the fluid to reduce the friction between surfaces that are under load. This ability reduces the damage that is caused by friction. Fuel injection systems rely on the lubricating properties of the fuel. Until fuel sulfur limits were mandated, the fuels lubricity was generally believed to be a function of fuel viscosity.

The lubricity has particular significance to the current ultra low sulfur fuel, and low aromatic fossil fuels. These fuels are made to meet stringent exhaust emissions.

The lubricity of these fuels must not exceed wear scar diameter of 0.52 mm (0.0205 inch). The fuel lubricity test must be performed on an HFRR, operated at 60 °C (140 °F). Refer to "ISO 12156-1".



---

**NOTICE**

The fuels system has been qualified with fuel having lubricity up to 0.52 mm (0.0205 inch) wear scar diameter as tested by "ISO 12156-1". Fuel with higher wear scar diameter than 0.52 mm (0.0205 inch) will lead to reduced service life and premature failure of the fuel system.

---

Fuel additives can enhance the lubricity of a fuel. Contact your fuel supplier for those circumstances when fuel additives are required. Your fuel supplier can make recommendations for additives to use, and for the proper level of treatment.

**Distillation**

Distillation is an indication of the mixture of different hydrocarbons in the fuel. A high ratio of lightweight hydrocarbons can affect the characteristics of combustion.

**Recommendation for Biodiesel and Using B20**

Biodiesel is a fuel that can be defined as mono-alkyl esters of fatty acids. Biodiesel is a fuel that can be made from various feedstocks. The most commonly available biodiesel in Europe is Rape Methyl Ester (RME). This biodiesel is derived from rapeseed oil. Soy Methyl Ester (SME) is the most common biodiesel in the United States. This biodiesel is derived from soybean oil. Soybean oil or rapeseed oil are the primary feedstocks. These fuels are together known as Fatty Acid Methyl Esters (FAME).

Raw pressed vegetable oils are NOT acceptable for use as a fuel in any concentration in compression engines. Without esterification, these oils solidify in the crankcase and the fuel tank. These fuels may not be compatible with many of the elastomers that are used in engines that are manufactured today. In original forms, these oils are not suitable for use as a fuel in compression engines. Alternate base stocks for biodiesel may include animal tallow, waste cooking oils, or various other feedstocks. To use any of the products that are listed as fuel, the oil must be esterified.

Fuel made of 100 percent FAME is generally referred to as B100 biodiesel or neat biodiesel.

Biodiesel can be blended with distillate diesel fuel. The blends can be used as fuel. The most commonly available biodiesel blends are B5, which is 5 percent biodiesel and 95 percent distillate diesel fuel. B20, which is 20 percent biodiesel and 80 percent distillate diesel fuel.

**Note:** The percentages given are volume-based.

The U.S. distillate diesel fuel specification "ASTM D975-09a" includes up to B5 (5 percent) biodiesel.

European distillate diesel fuel specification EN590: 2010 includes up to B7 (7 percent) biodiesel.

**Note:** Engines that are manufactured by Perkins are certified by use of the prescribed Environmental Protection Agency (EPA) and European Certification fuels. Perkins does not certify engines on any other fuel. The user of the engine has the responsibility of using the correct fuel that is recommended by the manufacturer and allowed by the EPA and other appropriate regulatory agencies.

**Specification Requirements**

The neat biodiesel must conform to the latest "EN14214 or ASTM D6751" (in the USA). The biodiesel can only be blended in mixture of up to 20% by volume in acceptable mineral diesel fuel meeting latest edition of "EN590 or ASTM D975 S15" designation.

In United States Biodiesel blends of B6 to B20 must meet the requirements listed in the latest edition of "ASTM D7467" (B6 to B20) and must be of an API gravity of 30-45.

In North America biodiesel and biodiesel blends must be purchased from the BQ-9000 accredited producers and BQ-9000 certified distributors.

In other areas of the world, the use of biodiesel that is BQ-9000 accredited and certified, or that is accredited and certified by a comparable biodiesel quality body to meet similar biodiesel quality standards is required.

**Engine Service Requirements**

Aggressive properties of biodiesel fuel may cause debris in the fuel tank and fuel lines. The aggressive properties of biodiesel will clean the fuel tank and fuel lines. This cleaning of the fuel system can prematurely block of the fuel filters. Perkins recommend that after the initial usage of B20 biodiesel blended fuel the fuel filters must be replaced at 50 hours.

Glycerides present in biodiesel fuel will also cause fuel filters to become blocked more quickly. Therefore the regular service interval should be reduced to 250 hours.

When biodiesel fuel is used, crank case oil and aftertreatment systems may be influenced. This influence is due to the chemical composition and characteristics of biodiesel fuel, such as density and volatility, and to chemical contaminants that can be present in this fuel, such as alkali and alkaline metals (sodium, potassium, calcium, and magnesium).

- Crankcase oil fuel dilution can be higher when biodiesel or biodiesel blends are used. This increased level of fuel dilution when using biodiesel or biodiesel blends is related to the typically lower volatility of biodiesel. In-cylinder emissions control strategies utilized in many of the industrial latest engine designs may lead to a higher level of biodiesel concentration in the sump. The long-term effect of biodiesel concentration in crankcase oil is unknown currently.
- Perkins recommend the use of oil analysis to check the quality of the engine oil if biodiesel fuel is used. Ensure that the level of biodiesel in the fuel is noted when the oil sample is taken.

### Performance Related Issues

Due to the lower energy content than the standard distillate fuel B20 will cause a power loss in order of 2 to 4 percent. In addition, over time the power may deteriorate further due to deposits in the fuel injectors.

Biodiesel and biodiesel blends are known to cause an increase in fuel system deposits, most significant of which are deposits within the fuel injector. These deposits can cause a loss in power due to restricted or modified fuel injection or cause other functional issues associated with these deposits.

**Note:** Perkins T40-0012 Fuel Cleaner is most effective in cleaning and preventing the formation of deposits. Perkins Diesel Fuel Conditioner helps to limit deposit issues by improving the stability of biodiesel and biodiesel blends. For more information refer to “Perkins Diesel Fuel System Cleaner, and Perkins”.

Biodiesel fuel contains metal contaminants (sodium, potassium, calcium, and/or magnesium) that form ash products upon combustion in the diesel engine. The ash can have an impact on the life and performance of aftertreatment emissions control devices and can accumulate in DPF. The ash accumulation may cause the need for more frequent ash service intervals and cause loss of performance

### General Requirements

Biodiesel has poor oxidation stability, which can result in long-term problems in the storage of biodiesel. Biodiesel fuel should be used within 6 months of manufacture. Equipment should not be stored with the B20 biodiesel blends in the fuel system for longer than 3 months.

Due to poor oxidation stability and other potential issues, it is strongly recommended that engines with limited operational time either not use B20 biodiesel blends or, whilst accepting some risk, limit biodiesel blend to a maximum of B5. Examples of applications that should limit the use of biodiesel are the following: Standby Generator sets and certain emergency vehicles.

For standby generator sets and emergency vehicles that cannot avoid use of biodiesel blends fuel quality in the engine fuel tank must be sampled and checked monthly. Test should include acid number (EN14104), oxidation stability (EN 15751 commonly known as the Rancimant test), and sediment (ISO12937). For standby generator sets oxidation stability of biodiesel blend must be 20 hours or more as per EN 15751. If the test shows that the fuel has degraded, fuel tank must be drained and engine flashed by running with the fresh high-quality diesel fuel.

Perkins strongly recommended that seasonally operated engines have the fuel systems, including fuel tanks, flashed with conventional diesel fuel before prolonged shutdown periods. An example of an application that should seasonally flush the fuel system is a combine harvester.

Microbial contamination and growth can cause corrosion in the fuel system and premature plugging of the fuel filter. Consult your supplier of fuel for assistance in selecting appropriate anti-microbial additive.

Water accelerates microbial contamination and growth. When biodiesel is compared to distillate fuels, water is naturally more likely to exist in the biodiesel. Therefore check frequently and if necessary, drain the water separator.

Materials such as brass, bronze, copper, lead, tin, and zinc accelerate the oxidation process of the biodiesel fuel. The oxidation process can cause deposits formation therefore these materials must not be used for fuel tanks and fuel lines.

### Renewable and Alternative Fuels

Perkins supports development and use of renewable fuels through sustainability initiatives. In recent years various forms of renewable and alternative (synthetic) diesel fuels have started to emerge.

Synthetic diesel fuels are produced by gasification of various feedstock and then synthesis to liquid to obtain paraffinic diesel fuel. Based on the feedstock used these fuels are commonly referred to as Biomass to liquid (BTL), Gas to liquid (GTL) and Coal to liquid (CTL). Hydrotreating of vegetable oils and animal fats is another emerging process for production of bio based diesel fuel called Hydrotreated Vegetable Oil (HVO).

BTL and HVO fuels are considered to be low carbon fuels as they reduce carbon foot print compared to fossil fuels and are commonly referred to as renewable fuels. These fuels must not be confused with biodiesel FAME which is fundamentally different fuel and is discussed in a separate section in this manual.

These paraffinic fuels have virtually no sulphur or aromatics and have very high cetane numbers which enable very clean burning and efficient engine operation. Chemically these fuels are similar to diesel fuel derived from petroleum and are therefore suitable to use in diesel engines as a replacement or blend stock with conventional diesel fuel. To be acceptable renewable and alternative fuels must meet latest edition of the paraffinic diesel fuel specification "CENTS 15940". The fuel should also meet requirements described in table 16, Perkins Specification for Distillate Diesel Fuel, EN590, or latest ASTM D975 specification.

Ensure that the fuel has got appropriate cold flow properties (cloud point and CFPP) for the minimum statistical ambient temperature the engine is expected to see in the operation. The Fuel must also meet lubricity requirements as specified in the lubricity section of this "Operation and Maintenance Manual" Fluid Recommendations

### Fuel for Cold-Weather Operation

The European standard "EN590" contains climate dependant requirements and a range of options. The options can be applied differently in each country. There are five classes that are given to arctic climates and severe winter climates. 0, 1, 2, 3 and 4.

Fuel that complies with "EN590" CLASS 4 can be used at temperatures as low as  $-44^{\circ}\text{C}$  ( $-47.2^{\circ}\text{F}$ ). Refer to "EN590" for a detailed discretion of the physical properties of the fuel.

The diesel fuel "ASTM D975 1-D" used in the United States of America may be used in very cold temperatures that are below  $-18^{\circ}\text{C}$  ( $-0.4^{\circ}\text{F}$ ).

### Aftermarket Fuel Additives

---

#### NOTICE

Perkins does not warrant the quality or performance of non-Perkins fluids and filters.

When auxiliary devices, accessories, or consumables (filters, additives) which are made by other manufacturers are used on Perkins products, the Perkins warranty is not affected simply because of such use.

**However, failures that result from the installation or use of other manufacturers devices, accessories, or consumables are NOT Perkins defects. Therefore, the defects are NOT covered under the Perkins warranty.**

---

Supplemental diesel fuel additives are not generally recommended. This recommendation is due to potential damage to the fuel system or the engine. Your fuel supplier or the fuel manufacturer will add the appropriate supplemental diesel fuel additives.

Perkins recognizes the fact that additives may be required in some special circumstances.

**Note:** Some anti-corrosion additives can lead to injector fouling, this fouling can cause the injector to operate incorrectly.

Contact your fuel supplier for those circumstances when fuel additives are required. Your fuel supplier can recommend the appropriate fuel additive and the correct level of treatment.

**Note:** For the best results, your fuel supplier should treat the fuel when additives are required. The treated fuel must meet the requirements that are stated in table 16.

### Perkins Diesel Fuel System Cleaner

Perkins T40-0012 Fuel Cleaner is the only fuel cleaner that is recommended by Perkins.

If biodiesel or biodiesel blends of fuel are to be used, Perkins require the use of Perkins fuel cleaner. The use of the fuel is to remove deposits within the fuel system that is created with the use of biodiesel. For more information on the use of biodiesel and biodiesel blends refer to "Recommendation for Biodiesel and Using B20".

Perkins fuel cleaner will remove deposits that can form in the fuel system with the use of biodiesel and biodiesel blends. These deposits can create a loss of power and engine performance.

Once the fuel cleaner has been added to the fuel, the deposits within the fuel system are removed after 30 hours of engine operation. For maximum results, continue to use the fuel cleaner for up to 80 hours. Perkins fuel cleaner can be used on an on-going basis with no adverse impact on engine or fuel system durability.

Details instruction on the rate of which the fuel cleaner must be use are on the container.

**Note:** Perkins fuel cleaner is compatible with existing and U.S. EPA Tier 4 nonroad certified diesel engine emission control catalysts and particulate filters. Perkins fuel system cleaner contains less than 15 ppm of sulfur and is acceptable for use with ULSD fuel.

## Contamination Control Recommendations for Fuels

Fuels of “ISO 18/16/13” cleanliness level or cleaner as dispensed into the engine or application fuel tank should be used. This will reduce risk of power loss, fuel system failures, and related down time of engines. This cleanliness level is important for new fuel system designs such as common rail injection systems and unit injectors. These fuels systems utilize higher fuel injection pressures and have tight clearances between moving parts to meet required stringent emissions regulations. Peak injection pressures in current fuel injection systems may exceed 2000 bar (29000 psi). Clearances in these systems are less than 5 µm. As a result, particle contaminants as small as 4 µm can cause scoring and scratching of internal pump and injector surfaces and of injector nozzles.

Water in the fuel causes cavitation, corrosion of fuel system parts, and provides an environment where microbial growth in the fuel can flourish. Other sources of fuel contamination are soaps, gels, or other compounds that may result from undesirable chemical interactions in the fuels, particularly in ULSD. Gels and other compounds can also form in biodiesel fuel at low temperatures or if biodiesel is stored for extended periods. The best indication of microbial contamination, fuel additives, or cold temperature gel is rapid filter plugging of bulk fuel filters or application fuel filters.

To reduce downtime due to contamination, follow these fuel maintenance guidelines.

- Use high-quality fuels per recommended and required specifications
- Fill fuel tanks with fuels of “ISO 18/16/13” cleanliness level or cleaner, in particular for engines with common rail and unit injection systems. When you refuel the tank, filter the fuel through a 4 µm absolute filter (Beta 4 = 75 up to 200) to reach the recommended cleanliness level. This filtration should be installed at the device that dispenses the fuel to the fuel tank. In addition, filtration at the dispensing point should remove water to ensure that fuel is dispensed at 500 ppm water or less.
- Perkins recommends the use of bulk fuel filter / coalescer units which clean the fuel of both particulate contamination and water in a single pass.
- Ensure that you use Perkins Advanced Efficiency Fuel Filters. Change your fuel filters per recommended service requirements or as needed.
- Drain your water separators daily.
- Drain your fuel tanks of sediment and water per the Operation and Maintenance Manual instructions.
- Install and maintain a properly designed bulk filter / coalescer filtration system. Continuous bulk filtration systems may be required to ensure that dispensed fuel meets the cleanliness target. Consult your Perkins distributor for availability of bulk filtration products.
- Centrifugal filters may need to be used as a pre-filter with fuel that is severely contaminated with gross amounts of water and/or large particulate contaminants. Centrifugal filters can effectively remove large contaminants. Centrifugal filters may not be able to remove the small abrasive particles required to achieve the recommended “ISO” cleanliness level. Bulk filter / coalescers are necessary as a final filter to achieve the recommended cleanliness level.
- Install desiccant type breathers of 4 µm or less absolute efficiency with the ability to remove water on bulk storage tanks.
- Follow proper practices of fuel transportation. Filtration from the storage tank to the application promotes the delivery of clean fuel. Fuel filtration can be installed at each transport stage to keep the fuel clean.
- Cover, protect, and ensure cleanliness of all connection hoses, fittings, and dispensing nozzles.

Consult your local Perkins distributor for additional information on Perkins designed and produced filtration products.

# Maintenance Recommendations

i07819420

## System Pressure Release

### Coolant System

#### WARNING

**Pressurized system: Hot coolant can cause serious burn. To open cap, stop engine, wait until radiator is cool. Then loosen cap slowly to relieve the pressure.**

#### WARNING

**When the engine is in the AUTOMATIC mode, the engine can start at any moment. To avoid personal injury, always remain clear of the engine when the engine is in the AUTOMATIC mode.**

The engine can have the ability to auto start. Ensure that the power supply is isolated before any service or repair is performed.

To relieve the pressure from the coolant system, turn off the engine. Allow the cooling system pressure cap to cool. Remove the cooling system pressure cap slowly to relieve pressure.

### Fuel System

To relieve the pressure from the fuel system, turn off the engine.

### High-Pressure Fuel Lines

#### WARNING

**Contact with high pressure fuel may cause fluid penetration and burn hazards. High pressure fuel spray may cause a fire hazard. Failure to follow these inspection, maintenance and service instructions may cause personal injury or death.**

The high-pressure fuel lines are the fuel lines that are between the high-pressure fuel pump and the high-pressure fuel manifold and the fuel lines that are between the fuel manifold and the fuel injectors.

The high-pressure fuel lines are different from fuel lines on other fuel systems, the differences are as follows:

- The high-pressure fuel lines are constantly charged with high pressure.
- The internal pressures of the high-pressure fuel lines are higher than other types of fuel system.

Before any service or repair is performed on the engine fuel lines, perform the following tasks:

1. Stop the engine.
2. Wait for 10 minutes.

Do not loosen the high-pressure fuel lines to remove air from the fuel system.

### Engine Oil

To relieve pressure from the lubricating system, turn off the engine.

i05400894

## Welding on Engines with Electronic Controls

#### NOTICE

Because the strength of the frame may decrease, some manufacturers do not recommend welding onto a chassis frame or rail. Consult the OEM of the equipment or your Perkins dealer regarding welding on a chassis frame or rail.

Proper welding procedures are necessary in order to avoid damage to the engines ECM, sensors, and associated components. When possible, remove the component from the unit and then weld the component. If removal of the component is not possible, the following procedure must be followed when you weld on a unit equipped with an Electronic Engine. The following procedure is considered to be the safest procedure to weld on a component. This procedure should provide a minimum risk of damage to electronic components.

#### NOTICE

Do not ground the welder to electrical components such as the ECM or sensors. Improper grounding can cause damage to the drive train bearings, hydraulic components, electrical components, and other components.

Clamp the ground cable from the welder to the component that will be welded. Place the clamp as close as possible to the weld. This will help reduce the possibility of damage.

**Note:** Perform the welding in areas that are free from explosive hazards.

Maintenance Section  
Welding on Engines with Electronic Controls

1. Stop the engine. Turn the switched power to the OFF position.
2. Ensure that the fuel supply to the engine is turned off.
3. Disconnect the negative battery cable from the battery. If a battery disconnect switch is provided, open the switch.
4. Disconnect all electronic components from the wiring harnesses. Include the following components:
  - Electronic components for the driven equipment
  - ECM
  - Sensors
  - Electronically controlled valves
  - Relays
  - Aftertreatment ID module

**NOTICE**

Do not use electrical components (ECM or ECM sensors) or electronic component grounding points for grounding the welder.

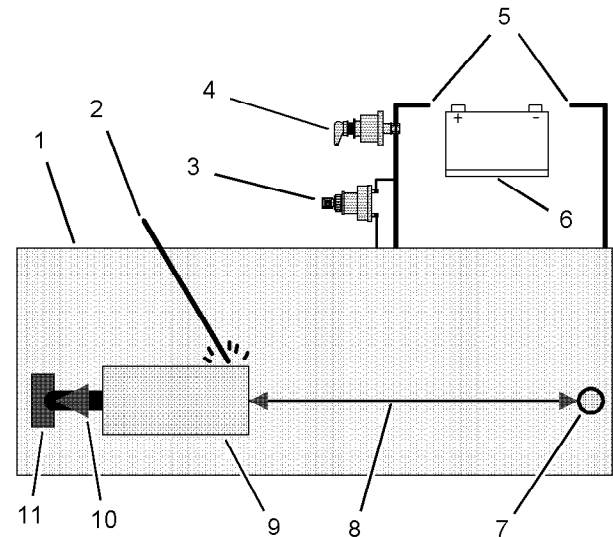

Illustration 44

g01075639

Use the example above. The current flow from the welder to the ground clamp of the welder will not damage any associated components.

- (1) Engine
- (2) Welding electrode
- (3) Keyswitch in the OFF position
- (4) Battery disconnect switch in the open position
- (5) Disconnected battery cables
- (6) Battery
- (7) Electrical/Electronic component
- (8) Minimum distance between the component that is being welded and any electrical/electronic component
- (9) The component that is being welded
- (10) Current path of the welder
- (11) Ground clamp for the welder

5. Connect the welding ground cable directly to the part that will be welded. Place the ground cable as close as possible to the weld in order to reduce the possibility of welding current damage to the following components. Bearings, hydraulic components, electrical components, and ground straps.

**Note:** If electrical/electronic components are used as a ground for the welder, or electrical/electronic components are located between the welder ground and the weld, current flow from the welder could severely damage the component.

6. Protect the wiring harness from welding debris and spatter.

7. Use standard welding practices to weld the materials.

i04150276

## Severe Service Application

Severe service is the application of an engine that exceeds the current published standards for that engine. Perkins maintains standards for the following engine parameters:

- Performance such as power range, speed range, and fuel consumption
- Fuel quality
- Operational Altitude
- Maintenance intervals
- Oil selection and maintenance
- Coolant type and maintenance
- Environmental qualities
- Installation
- The temperature of the fluid in the engine

Refer to the standards for the engine or consult your Perkins dealer or your Perkins distributor in order to determine if the engine is operating within the defined parameters.

Severe service operation can accelerate component wear. Engines that operate under severe conditions may need more frequent maintenance intervals in order to ensure maximum reliability and retention of full service life.

Due to individual applications, it is not possible to identify all of the factors which can contribute to severe service operation. Consult your Perkins dealer or your Perkins distributor for the unique maintenance that is necessary for the engine.

The operating environment, incorrect operating procedures, and incorrect maintenance procedures can be factors which contribute to a severe service application.

## Environmental Factors

**Ambient temperatures** – The engine may be exposed to extended operation in cold environments or hot environments. Valve components can be damaged by carbon buildup if the engine is frequently started and stopped in cold temperatures. Hot intake air reduces engine performance.

**Quality of the air** – The engine may be exposed to extended operation in an environment that is dirty or

dusty, unless the equipment is cleaned regularly. Mud, dirt, and dust can encase components. Maintenance can be difficult. The buildup can contain corrosive chemicals.

**Buildup** – Compounds, elements, corrosive chemicals, and salt can damage some components.

**Altitude** – Problems can arise when the engine is operated at altitudes that are higher than the intended settings for that application. Necessary adjustments should be made.

## Incorrect Operating Procedures

- Extended operation at low idle
- Frequent hot shutdowns
- Operating at excessive loads
- Operating at excessive speeds
- Operating outside the intended application

## Incorrect Maintenance Procedures

- Extending the maintenance intervals
- Failure to use recommended fuel, lubricants, and coolant/antifreeze

i05325425

## Maintenance Interval Schedule

### When Required

“ Battery - Replace”	91
“ Battery or Battery Cable - Disconnect”	92
“ Engine - Clean”	99
“ Engine Air Cleaner Element (Single Element) - Inspect/Clean/Replace”	100
“ Engine Oil Sample - Obtain”	103
“ Fuel System - Prime”	107

### Daily

“ Coolant Level - Check”	97
“ Driven Equipment - Check”	99
“ Engine Air Cleaner Service Indicator - Inspect”	100
“ Engine Air Precleaner - Check/Clean”	101
“ Engine Oil Level - Check”	102
“ Fuel System Primary Filter/Water Separator - Drain”	110
“Walk-Around Inspection”	116

### Every Week

“ Hoses and Clamps - Inspect/Replace”	112
---------------------------------------	-----

### Every 50 Service Hours or Weekly

“ Fuel Tank Water and Sediment - Drain”	112
---	-----

### Every 50 Service Hours or Monthly

“ Fuel Tank Water and Sediment - Drain”	112
---	-----

### Every 500 Service Hours

“ Fan Clearance - Check”	106
--------------------------	-----

### Every 500 Service Hours or 1 Year

“ Battery Electrolyte Level - Check”	92
“ Cooling System Supplemental Coolant Additive (SCA) - Test/Add”	98

“ Engine Air Cleaner Element (Single Element) - Inspect/Clean/Replace”	100
“ Engine Oil and Filter - Change”	103
“ Fuel System Primary Filter (Water Separator) Element - Replace”	108
“ Fuel System Secondary Filter - Replace”	110
“ Radiator - Clean”	114

### Every 1000 Service Hours

“ Water Pump - Inspect”	117
-------------------------	-----

### Every 1500 Service Hours

“Engine Crankcase Breather Element - Replace”	101
---	-----

### Every 2000 Service Hours

“ Aftercooler Core - Inspect”	90
“ Engine Mounts - Inspect”	102
“ Starting Motor - Inspect”	115
“ Turbocharger - Inspect”	115

### Every 3000 Service Hours

“ Alternator - Inspect”	90
“ Alternator and Fan Belts - Replace”	90
“ Diesel Particulate Filter - Clean”	99
“ Oxygen Sensor - Replace”	114



“ Radiator Pressure Cap - Clean/Replace” . . . . . 115

**Every 3000 Service Hours or 2  
Years**

“ Coolant (Commercial Heavy-Duty) - Change” . . . 93

**Every 4000 Service Hours**

“ Aftercooler Core - Clean/Test” . . . . . 90

**Every 6000 Service Hours or 3  
Years**

“ Coolant Extender (ELC) - Add” . . . . . 96

**Every 12 000 Service Hours or 6  
Years**

“ Coolant (ELC) - Change” . . . . . 94

**Commissioning**

“ Fan Clearance - Check” . . . . . 106

i01807350

i02322311

## Aftercooler Core - Clean/Test (Air-To-Air Aftercooler)

The air-to-air aftercooler is OEM installed in many applications. Please refer to the OEM specifications for information that is related to the aftercooler.

i02322295

## Aftercooler Core - Inspect

**Note:** Adjust the frequency of cleaning according to the effects of the operating environment.

Inspect the aftercooler for these items: damaged fins, corrosion, dirt, grease, insects, leaves, oil and other debris. Clean the aftercooler, if necessary.

For air-to-air aftercoolers, use the same methods that are used for cleaning radiators.

### **WARNING**

**Personal injury can result from air pressure.**

**Personal injury can result without following proper procedure. When using pressure air, wear a protective face shield and protective clothing.**

**Maximum air pressure at the nozzle must be less than 205 kPa (30 psi) for cleaning purposes.**

After cleaning, start the engine and accelerate the engine to high idle rpm. This will help in the removal of debris and drying of the core. Stop the engine. Use a light bulb behind the core in order to inspect the core for cleanliness. Repeat the cleaning, if necessary.

Inspect the fins for damage. Bent fins may be opened with a "comb".

**Note:** If parts of the aftercooler system are repaired or replaced, a leak test is highly recommended.

Inspect these items for good condition: Welds, mounting brackets, air lines, connections, clamps and seals. Make repairs, if necessary.

## Alternator - Inspect

Perkins recommends a scheduled inspection of the alternator. Inspect the alternator for loose connections and correct battery charging. Check the ammeter (if equipped during engine operation in order to ensure correct battery performance and/or correct performance of the electrical system. Make repairs, as required.

Check the alternator and the battery charger for correct operation. If the batteries are correctly charged, the ammeter reading should be very near zero. All batteries should be kept charged. The batteries should be kept warm because temperature affects the cranking power. If the battery is too cold, the battery will not crank the engine. When the engine is not run for long periods of time or if the engine is run for short periods, the batteries may not fully charge. A battery with a low charge will freeze more easily than a battery with a full charge.

i04407613

## Alternator and Fan Belts - Replace

1. Remove the guard that covers the alternator. Refer to the Original Equipment Manufacture (OEM) for the correct procedure.

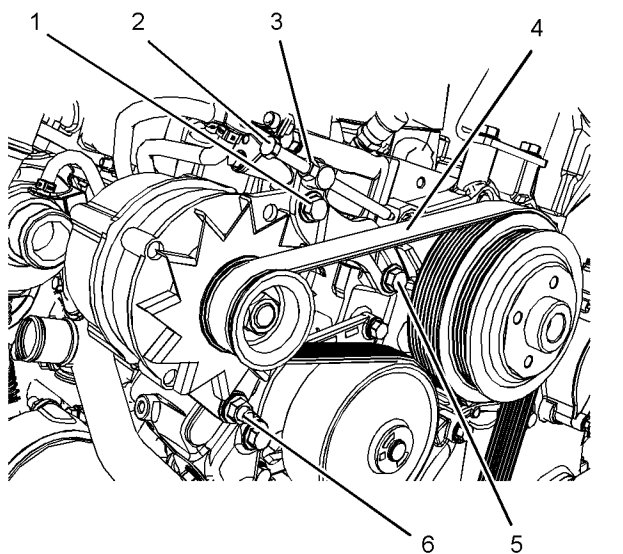

Illustration 45

g02729648

2. Loosen bolt (5) and loosen nut and bolt 6. Also, loosen nut and bolt (1).
3. Loosen nut (3) and turn screw (2) counter clockwise. Turn the screw (2) in order to give clearance to remove the belt (4).
4. Remove belt (4) and visually check all pulleys that the belt operates. Ensure that all pulleys are clean and free from damage. Ensure that the pulleys rotate freely. Replace any component that is damaged.

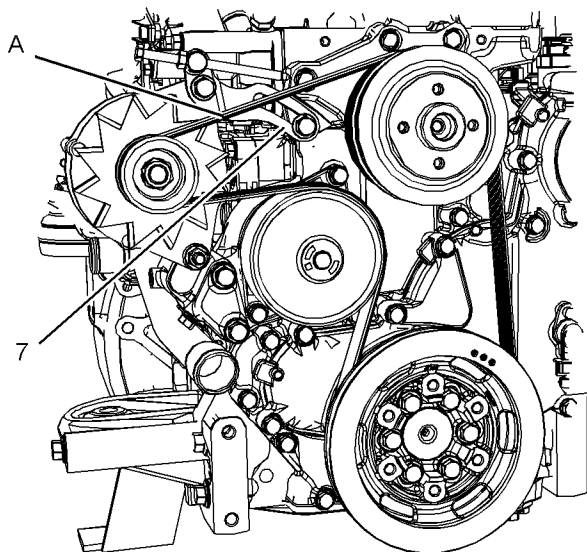

Illustration 46

g02603591

(A) Belt configuration

5. Install the new belt, use belt configuration (A). Visually check that the belt is correctly aligned.
6. Turn the screw (2) clockwise in order to tension the belt. Ensure that the link adjuster (7) is at the maximum extension, refer to illustration 46 .
7. Tighten bolt (5), nut, and bolt (6) and tighten nut and bolt (1). Tighten these nuts and bolts to 50 N·m (37 lb ft).
8. Rotate bolt (2) counter clockwise two complete revolutions and tighten nut (3) to 30 N·m (22 lb ft).
9. Install the guard, refer to OEM for more information.

i03559623

## Battery - Replace

### WARNING

Batteries give off combustible gases which can explode. A spark can cause the combustible gases to ignite. This can result in severe personal injury or death.

Ensure proper ventilation for batteries that are in an enclosure. Follow the proper procedures in order to help prevent electrical arcs and/or sparks near batteries. Do not smoke when batteries are serviced.

### WARNING

The battery cables or the batteries should not be removed with the battery cover in place. The battery cover should be removed before any servicing is attempted.

Removing the battery cables or the batteries with the cover in place may cause a battery explosion resulting in personal injury.

1. Switch the engine to the OFF position. Remove all electrical loads.
2. Turn off any battery chargers. Disconnect any battery chargers.
3. Ensure that the battery disconnect switch is in the OFF position.
4. Disconnect the NEGATIVE “-” cable from the NEGATIVE “-” battery terminal.
5. Disconnect the POSITIVE “+” cable from the POSITIVE “+” battery terminal.

**Note:** Always recycle a battery. Never discard a battery. Dispose of used batteries to an appropriate recycling facility.

6. Remove the used battery.
7. Install the new battery.

**Note:** Before the cables are connected, ensure that the battery disconnect switch is in the OFF position.

8. Connect the POSITIVE "+" cable to the POSITIVE "+" battery terminal.
9. Connect the NEGATIVE "-" cable to the NEGATIVE "-" battery terminal.
10. Turn the battery disconnect switch to the ON position.

i02747977

## Battery Electrolyte Level - Check

When the engine is not run for long periods of time or when the engine is run for short periods, the batteries may not fully recharge. Ensure a full charge in order to help prevent the battery from freezing. If batteries are correctly charged, the ammeter reading should be very near zero, when the engine is in operation.

### WARNING

**All lead-acid batteries contain sulfuric acid which can burn the skin and clothing. Always wear a face shield and protective clothing when working on or near batteries.**

1. Remove the filler caps. Maintain the electrolyte level to the "FULL" mark on the battery.

If the addition of water is necessary, use distilled water. If distilled water is not available use clean water that is low in minerals. Do not use artificially softened water.

2. Check the condition of the electrolyte with a suitable battery tester.
3. Install the caps.
4. Keep the batteries clean.

Clean the battery case with one of the following cleaning solutions:

- Use a solution of 0.1 kg (0.2 lb) baking soda and 1 L (1 qt) of clean water.
- Use a solution of ammonium hydroxide.

Thoroughly rinse the battery case with clean water.

i07819485

## Battery or Battery Cable - Disconnect

### WARNING

**The battery cables or the batteries should not be removed with the battery cover in place. The battery cover should be removed before any servicing is attempted.**

**Removing the battery cables or the batteries with the cover in place may cause a battery explosion resulting in personal injury.**

1. Turn the start switch to the OFF position. Turn the ignition switch (if equipped) to the OFF position and remove the key and all electrical loads.
2. Disconnect the negative battery terminal. Ensure that the cable cannot contact the terminal. When four 12 volt batteries are involved, two negative connection must be disconnected.
3. Remove the positive connection.
4. Clean all disconnected connection and battery terminals.
5. Use a fine grade of sandpaper to clean the terminals and the cable clamps. Clean the items until the surfaces are bright or shiny. DO NOT remove material excessively. Excessive removal of material can cause the clamps to not fit correctly. Coat the clamps and the terminals with a suitable silicone lubricant or petroleum jelly.
6. Tape the cable connections to help prevent accidental starting.
7. Proceed with necessary system repairs.
8. To connect the battery, connect the positive connection before the negative connection.

i05326349

## Coolant (Commercial Heavy-Duty) - Change

### NOTICE

Care must be taken to ensure that fluids are contained during performance of inspection, maintenance, testing, adjusting and repair of the product. Be prepared to collect the fluid with suitable containers before opening any compartment or disassembling any component containing fluids.

Dispose of all fluids according to Local regulations and mandates.

### NOTICE

Keep all parts clean from contaminants.

Contaminants may cause rapid wear and shortened component life.

Clean the cooling system and flush the cooling system before the recommended maintenance interval if the following conditions exist:

- The engine overheats frequently.
- Foaming of the coolant is observed.
- The oil has entered the cooling system and the coolant is contaminated.
- The fuel has entered the cooling system and the coolant is contaminated.

**Note:** When the cooling system is cleaned, only clean water is needed.

### NOTICE

When any servicing or repair of the engine cooling system is performed, the procedure must be performed with the engine on level ground. This action will allow you to check accurately the coolant level. This action will also help in avoiding the risk of introducing an air lock into the coolant system.

## Drain

### WARNING

**Pressurized System: Hot coolant can cause serious burns. To open the cooling system filler cap, stop the engine and wait until the cooling system components are cool. Loosen the cooling system pressure cap slowly in order to relieve the pressure.**

1. Stop the engine and allow the engine to cool. Loosen the cooling system filler cap slowly in order to relieve any pressure. Remove the cooling system filler cap.

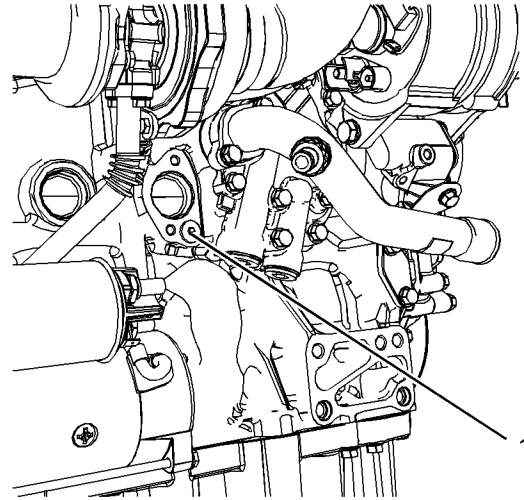

Illustration 47

g02513896

Typical example

2. Remove the drain plug (1) on the engine. Also, open drain cock or remove the drain plug on the radiator.

Allow the coolant to drain.

### NOTICE

Dispose of used engine coolant or recycle. Various methods have been proposed to reclaim used coolant for reuse in engine cooling systems. The full distillation procedure is the only method acceptable by Perkins to reclaim the coolant.

For information regarding the disposal and the recycling of used coolant, consult your Perkins dealer or your Perkins distributor.

## Flush

1. Flush the cooling system with clean water in order to remove any debris.
2. Install the drain plug on the engine. Close the drain cock or install the drain plug on the radiator.

Maintenance Section  
Coolant (ELC) - Change

**NOTICE**

Do not fill the cooling system faster than 5 L (1.3 US gal) per minute, in order to avoid air locks.

Cooling system air locks may result in engine damage.

3. Fill the cooling system with clean water. Install the cooling system filler cap.
4. Start and run the engine at low idle until the temperature reaches 49 to 66 °C (120 to 150 °F).
5. Stop the engine and allow the engine to cool. Loosen the cooling system filler cap slowly in order to relieve any pressure. Remove the cooling system filler cap. Remove the drain plug on the engine. Open the drain cock or remove the drain plug on the radiator. Allow the water to drain. Flush the cooling system with clean water.

**Fill**

1. Install the drain plug on the engine. Close the drain cock or install the drain plug on the radiator.

**NOTICE**

Do not fill the cooling system faster than 5 L (1.3 US gal) per minute, in order to avoid air locks.

Cooling system air locks may result in engine damage.

2. Fill the cooling system with Commercial Heavy-Duty Coolant. Add Supplemental Coolant Additive to the coolant. For the correct amount, refer to the Operation and Maintenance Manual, "Fluid Recommendations" topic (Maintenance Section) for more information on cooling system specifications. Do not install the cooling system filler cap.
3. Start and run the engine at low idle. Increase the engine rpm to high idle. Operate the engine in order to open the engine thermostat. This operation will allow any air in the system to be purged. Decrease the engine speed to low idle. Stop the engine.
4. Maintain the coolant level at the maximum mark that is correct for your application.

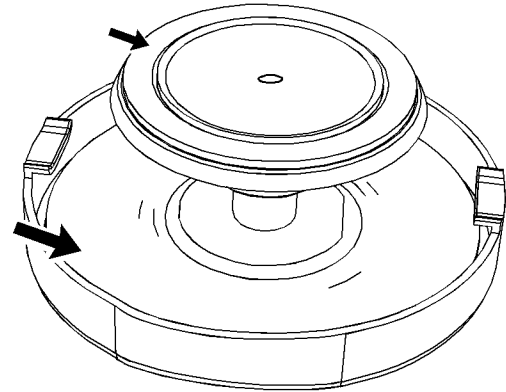

Illustration 48

g02590196

**Filler cap**

5. Clean the cooling system filler cap and inspect the gasket. If the gasket is damaged, discard the old filler cap and install a new filler cap. If the gasket is not damaged, use a suitable pressurizing pump in order to pressure test the filler cap. The correct pressure is stamped on the face of the filler cap. If the filler cap does not retain the correct pressure, install a new filler cap.
6. Start the engine. Inspect the cooling system for leaks and for correct operating temperature.

i05944034

**Coolant (ELC) - Change****NOTICE**

Care must be taken to ensure that fluids are contained during performance of inspection, maintenance, testing, adjusting and repair of the product. Be prepared to collect the fluid with suitable containers before opening any compartment or disassembling any component containing fluids.

Dispose of all fluids according to Local regulations and mandates.

**NOTICE**

Keep all parts clean from contaminants.

Contaminants may cause rapid wear and shortened component life.

Clean the cooling system and flush the cooling system before the recommended maintenance interval if the following conditions exist:

- The engine overheats frequently.
- Foaming of the coolant is observed.
- The oil has entered the cooling system and the coolant is contaminated.
- The fuel has entered the cooling system and the coolant is contaminated.

**Note:** When the cooling system is cleaned, only clean water is needed when the ELC is drained and replaced.

**Note:** Inspect the water pump and the water temperature regulator after the cooling system has been drained. This inspection can be a good opportunity to replace the water pump, the water temperature regulator, and the hoses, if necessary.

#### NOTICE

When any servicing or repair of the engine cooling system is performed, the procedure must be performed with the engine on level ground. Level ground will allow you to check accurately the coolant level. This check will also help in avoiding the risk of introducing an air lock into the coolant system.

## Drain

### WARNING

**Pressurized System:** Hot coolant can cause serious burns. To open the cooling system filler cap, stop the engine and wait until the cooling system components are cool. Loosen the cooling system pressure cap slowly in order to relieve the pressure.

1. Stop the engine and allow the engine to cool. Loosen the cooling system filler cap slowly in order to relieve any pressure. Remove the cooling system filler cap.

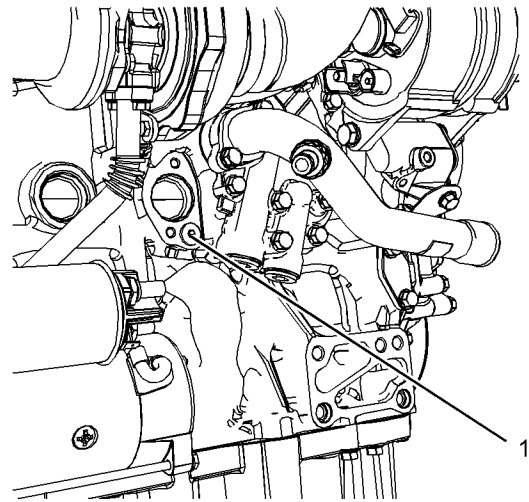

Illustration 49

g02513896

Typical example

2. Remove the drain plug (1) on the engine. Also, open the drain cock or remove the drain plug on the radiator.

Allow the coolant to drain.

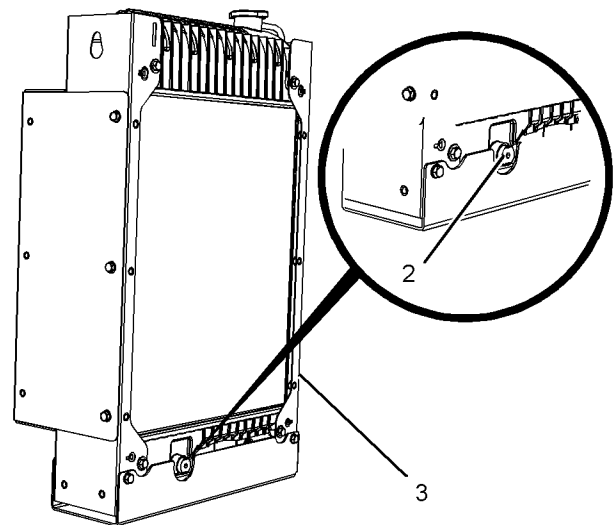

Illustration 50

g03732615

3. For radiators installed by the engine manufacturer, remove the drain plug (2) from radiator (3) and allow coolant to drain. After the system has been flushed, install the drain plug to a torque of 6 N·m (53 lb in).

**NOTICE**

Dispose of used engine coolant or recycle. Various methods have been proposed to reclaim used coolant for reuse in engine cooling systems. The full distillation procedure is the only method acceptable by Perkins to reclaim the coolant.

For information regarding the disposal and the recycling of used coolant, consult your Perkins distributor.

**Flush**

1. Flush the cooling system with clean water in order to remove any debris.
2. Install the drain plug in the engine. Close the drain cock or install the drain plug on the radiator.
3. Fill the cooling system with clean water. Install the cooling system filler cap.
4. Start and run the engine at low idle until the temperature reaches 49 to 66 °C (120 to 150 °F).
5. Stop the engine and allow the engine to cool. Loosen the cooling system filler cap slowly in order to relieve any pressure. Remove the cooling system filler cap. Remove the drain plug on the engine. Open the drain cock or remove the drain plug on the radiator. Allow the water to drain. Flush the cooling system with clean water.

**Fill**

1. Install the drain plug on the engine. Close the drain cock or install the drain plug on the radiator.

**NOTICE**

Do not fill the cooling system faster than 5 L (1.3 US gal) per minute, in order to avoid air locks.

Cooling system air locks may result in engine damage.

2. Fill the cooling system with Extended Life Coolant (ELC). Refer to the Operation and Maintenance Manual, "Fluid Recommendations" topic (Maintenance Section) for more information on cooling system specifications. Do not install the cooling system filler cap.
3. Start and run the engine at low idle. Increase the engine rpm to high idle. Operate the engine in order to open the engine thermostat. This procedure will allow any air in the system to be purged. Decrease the engine speed to low idle. Stop the engine.

4. Maintain the coolant level at the maximum mark that is correct for your application.

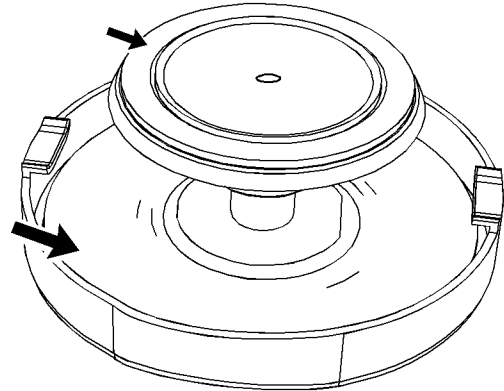

Illustration 51

g02590196

**Filler cap**

5. Clean the cooling system filler cap and inspect the gasket. If the gasket is damaged, discard the old filler cap and install a new filler cap. If the gasket is not damaged, use a suitable pressurizing pump in order to pressure test the filler cap. The correct pressure is stamped on the face of the filler cap. If the filler cap does not retain the correct pressure, install a new filler cap.
6. Start the engine. Inspect the cooling system for leaks and for correct operating temperature.

i05197396

**Coolant Extender (ELC) - Add**

In order for Perkins ELC to achieve 12000 hours an extender must be added at 6000 hours. For a suitable extender, contact your Perkins dealer or Perkins distributor.



i05149389

## Coolant Level - Check

### Engines With a Coolant Recovery Tank

**Note:** The cooling system may not have been provided by Perkins. The procedure that follows is for typical cooling systems. Refer to the OEM information for the correct procedures.

Check the coolant level when the engine is stopped and cool.

#### NOTICE

When any servicing or repair of the engine cooling system is performed, the procedure must be performed with the engine on level ground. Level ground will allow you to check accurately the coolant level. This checking will also help in avoiding the risk of introducing an air lock into the coolant system.

1. Observe the coolant level in the coolant recovery tank. Maintain the coolant level to "COLD FULL" mark on the coolant recovery tank.

#### WARNING

**Pressurized System:** Hot coolant can cause serious burns. To open the cooling system filler cap, stop the engine and wait until the cooling system components are cool. Loosen the cooling system pressure cap slowly in order to relieve the pressure.

2. Loosen filler cap slowly in order to relieve any pressure. Remove the filler cap.
3. Pour the correct coolant mixture into the tank. Refer to the Operation and Maintenance Manual, "Refill Capacities and Recommendations" for information on the correct mixture and type of coolant. Refer to the Operation and Maintenance Manual, "Refill Capacities and Recommendations" for the engine cooling system capacity. Do not fill the coolant recovery tank above "COLD FULL" mark.

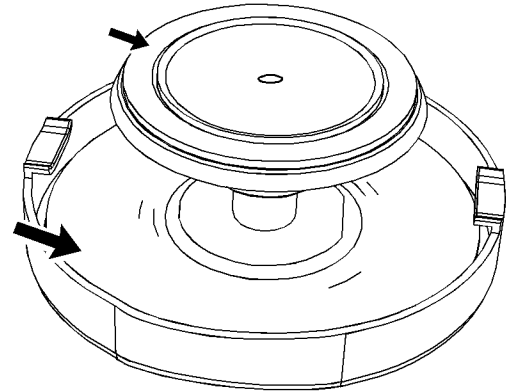

Illustration 52

g02590196

Filler cap

4. Clean the filler cap and the receptacle. Reinstall the filler cap and inspect the cooling system for leaks.

**Note:** The coolant will expand as the coolant heats up during normal engine operation. The additional volume will be forced into the coolant recovery tank during engine operation. When the engine is stopped and cool, the coolant will return to the engine.

### Engines Without a Coolant Recovery Tank

Check the coolant level when the engine is stopped and cool.

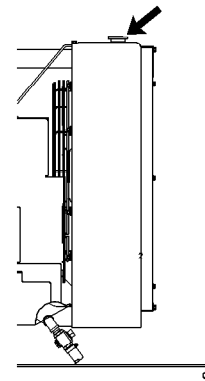

Illustration 53

g00285520

Cooling system filler cap

### **WARNING**

**Pressurized System: Hot coolant can cause serious burns. To open the cooling system filler cap, stop the engine and wait until the cooling system components are cool. Loosen the cooling system pressure cap slowly in order to relieve the pressure.**

1. Remove the cooling system filler cap slowly in order to relieve pressure.
2. Maintain the coolant level at the maximum mark that is correct for your application. If the engine is equipped with a sight glass, maintain the coolant level to the correct level in the sight glass.
3. Clean the cooling system filler cap and inspect the gasket. If the gasket is damaged, discard the old filler cap and install a new filler cap. If the gasket is not damaged, use a suitable pressurizing pump in order to pressure test the filler cap. The correct pressure is stamped on the face of the filler cap. If the filler cap does not retain the correct pressure, install a new filler cap.
4. Inspect the cooling system for leaks.

i03644948

## Cooling System Supplemental Coolant Additive (SCA - Test/Add

### **WARNING**

**Cooling system coolant additive contains alkali. To help prevent personal injury, avoid contact with the skin and the eyes. Do not drink cooling system coolant additive.**

## Test for SCA Concentration

### Heavy-Duty Coolant/Antifreeze and SCA

#### NOTICE

Do not exceed the recommended six percent supplemental coolant additive concentration.

Use a Coolant Conditioner Test Kit in order to check the concentration of the SCA.

## Add the SCA, If Necessary

#### NOTICE

Do not exceed the recommended amount of supplemental coolant additive concentration. Excessive supplemental coolant additive concentration can form deposits on the higher temperature surfaces of the cooling system, reducing the engine's heat transfer characteristics. Reduced heat transfer could cause cracking of the cylinder head and other high temperature components. Excessive supplemental coolant additive concentration could also result in radiator tube blockage, overheating, and/or accelerated water pump seal wear. Never use both liquid supplemental coolant additive and the spin-on element (if equipped) at the same time. The use of those additives together could result in supplemental coolant additive concentration exceeding the recommended maximum.

### **WARNING**

**Pressurized System: Hot coolant can cause serious burns. To open the cooling system filler cap, stop the engine and wait until the cooling system components are cool. Loosen the cooling system pressure cap slowly in order to relieve the pressure.**

#### NOTICE

When any servicing or repair of the engine cooling system is performed the procedure must be performed with the engine on level ground. This will allow you to accurately check the coolant level. This will also help in avoiding the risk of introducing an air lock into the coolant system.

1. Slowly loosen the cooling system filler cap in order to relieve the pressure. Remove the cooling system filler cap.

**Note:** Always discard drained fluids according to local regulations.

2. If necessary, drain some coolant from the cooling system into a suitable container in order to allow space for the extra SCA.
3. Add the correct amount of SCA. Refer to the Operation and Maintenance Manual, "Refill Capacities and Recommendations" for more information on SCA requirements.

4. Clean the cooling system filler cap and inspect the gasket. If the gasket is damaged, discard the old filler cap and install a new filler cap. If the gasket is not damaged, use a suitable pressurizing pump in order to pressure test the filler cap. The correct pressure is stamped on the face of the filler cap. If the filler cap does not retain the correct pressure, install a new filler cap.

i04650530

## Diesel Particulate Filter - Clean

### **WARNING**

Wear goggles, gloves, protective clothing, and a National Institute for Occupational Safety and Health (NIOSH) approved P95 or N95 half-face respirator when handling a used Diesel Particulate Filter or Catalytic Converter Muffler. Failure to do so could result in personal injury.

### **WARNING**

The muffler, catalytic converter/muffler, and diesel particulate filter will become extremely hot during engine operation. A hot muffler, catalytic converter/muffler and diesel particulate filter can cause serious burns. Allow adequate cooling time before working on or near the muffler, catalytic converter/muffler and diesel particulate filter.

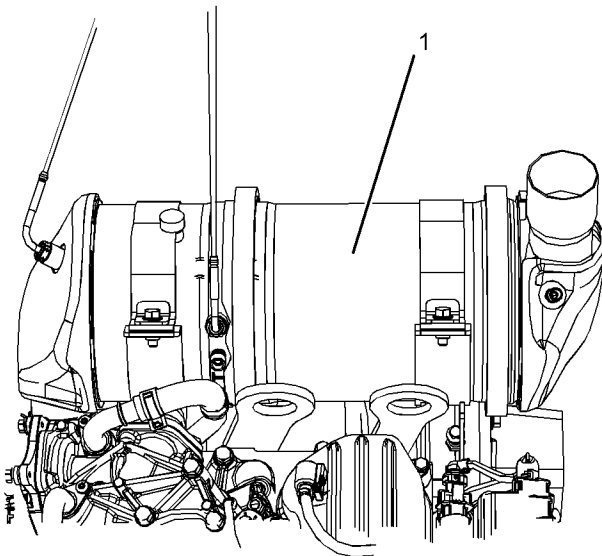

Illustration 54

g02524596

Typical example

**Note:** Only the wall flow type of aftertreatment requires a service period, in order to remove the ash. The wall flow aftertreatment uses active regeneration in order to remove soot.

For information on removal of the (1) diesel particulate filter, refer to Disassembly and Assembly, "DPF - Remove". Also, refer to System Operation Testing and Adjusting, "Diesel Particulate Filter - Clean".

i02151646

## Driven Equipment - Check

Refer to the OEM specifications for more information on the following maintenance recommendations for the driven equipment:

- Inspection
- Adjustment
- Lubrication
- Other maintenance recommendations

Perform any maintenance for the driven equipment which is recommended by the OEM.

i07819515

## Engine - Clean

### **WARNING**

Personal injury or death can result from high voltage.

Moisture can create paths of electrical conductivity.

Make sure that the electrical system is OFF. Lock out the starting controls and tag the controls "DO NOT OPERATE".

### NOTICE

Accumulated grease and oil on an engine is a fire hazard. Keep the engine clean. Remove debris and fluid spills whenever a significant quantity accumulates on the engine.

Periodic cleaning of the engine is recommended. Steam cleaning the engine will remove accumulated oil and grease. A clean engine provides the following benefits:

- Easy detection of fluid leaks
- Maximum heat transfer characteristics

## Maintenance Section

## Engine Air Cleaner Element (Single Element) - Inspect/Clean/Replace

- Ease of maintenance

**Note:** Caution must be used to prevent electrical components from being damaged by excessive water when the engine is cleaned. Pressure washers and steam cleaners should not be directed at any electrical connectors or the junction of cables into the rear of the connectors. Avoid electrical components such as the alternator, the starter, and the ECM. Protect the fuel injection pump from fluids to wash the engine.

Ensure that care is taken that the safety labels, emission label, and all other information labels are not removed during engine cleaning.

## Aftertreatment

During the engine cleaning process, ensure that water or cleaning fluids cannot enter the aftertreatment system. If cleaning fluids enters the aftertreatment system, damage could occur.

i06804009

## Engine Air Cleaner Element (Single Element - Inspect/Clean/Replace

Refer to Operation and Maintenance Manual, "Engine Air Cleaner Service Indicator-Inspect".

### NOTICE

Never run the engine without an air cleaner element installed. Never run the engine with a damaged air cleaner element. Do not use air cleaner elements with damaged pleats, gaskets or seals. Dirt entering the engine causes premature wear and damage to engine components. Air cleaner elements help to prevent airborne debris from entering the air inlet.

### NOTICE

Never service the air cleaner element with the engine running since this will allow dirt to enter the engine.

A wide variety of air cleaners may be installed for use with this engine. Consult the OEM information for the correct procedure to replace the air cleaner.

i02335405

## Engine Air Cleaner Service Indicator - Inspect

Some engines may be equipped with a different service indicator.

Some engines are equipped with a differential gauge for inlet air pressure. The differential gauge for inlet air pressure displays the difference in the pressure that is measured before the air cleaner element and the pressure that is measured after the air cleaner element. As the air cleaner element becomes dirty, the pressure differential rises. If your engine is equipped with a different type of service indicator, follow the OEM recommendations in order to service the air cleaner service indicator.

The service indicator may be mounted on the air cleaner element or in a remote location.

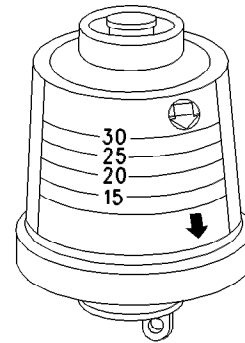

Illustration 55

g00103777

Typical service indicator

Observe the service indicator. The air cleaner element should be cleaned or the air cleaner element should be replaced when one of the following conditions occur:

- The yellow diaphragm enters the red zone.
- The red piston locks in the visible position.

## Test the Service Indicator

Service indicators are important instruments.

- Check for ease of resetting. The service indicator should reset in less than three pushes.
- Check the movement of the yellow core when the engine is accelerated to the engine rated speed. The yellow core should latch at the greatest vacuum that is attained.

If the service indicator does not reset easily, or if the yellow core does not latch at the greatest vacuum, the service indicator should be replaced. If the new service indicator will not reset, the hole for the service indicator may be restricted.

The service indicator may need to be replaced frequently in environments that are severely dusty.

i05967804

## Engine Air Precleaner - Check/ Clean (If Equipped)

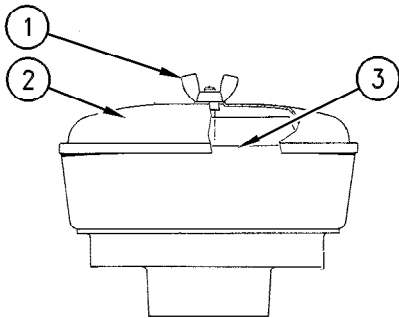

Illustration 56

g00287039

### Typical example

- (1) Wing nut
- (2) Cover
- (3) Body

Remove wing nut (1) and cover (2). Check for an accumulation of dirt and debris in body (3). Clean the body, if necessary.

After cleaning the pre-cleaner, install cover (2) and wing nut (1).

**Note:** When the engine is operated in dusty applications, more frequent cleaning is required.

i04725716

## Engine Crankcase Breather Element - Replace

### WARNING

Hot oil and hot components can cause personal injury. Do not allow hot oil or hot components to contact the skin.

## Engine Breather

### NOTICE

Ensure that the engine is stopped before any servicing or repair is performed.

The crankcase breather is a very important component in order to keep your engine emissions compliant.

- The filter element within the crankcase breather must be serviced at the prescribed service interval.
- The correct filter element must be installed before the engine is operated.
- The installation of the filter element is very important.
- The quality of the filter element that is installed is very important.
- The filter element protects the engine from excessive quantities of oil from entering the induction system. The filter element also protects the engine aftertreatment system.

**Note:** Excessive quantities of oil that enter the induction system of the engine can rapidly increase the engine speed without control.

### Remove the Breather Element

1. Remove the guard that covers the engine breather, refer to the Original Equipment Manufacture (OEM) for more information.

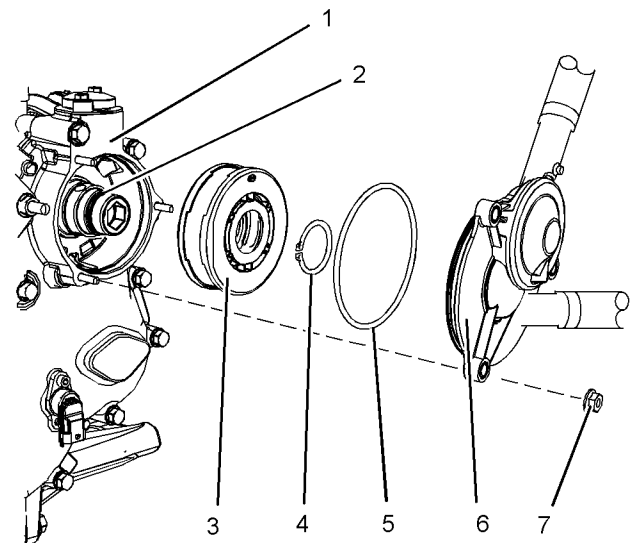

Illustration 57

g02827199

Typical example

2. If necessary, remove breather pipes on cover (6). Remove nuts (7) and remove cover (6) from housing (1).
3. Remove circlip (4) and remove the breather element (3) and discard.
4. Remove the O ring seal (5) from the cover.

### Install the Breather Element

Ensure that all the components are clean and free from damage.

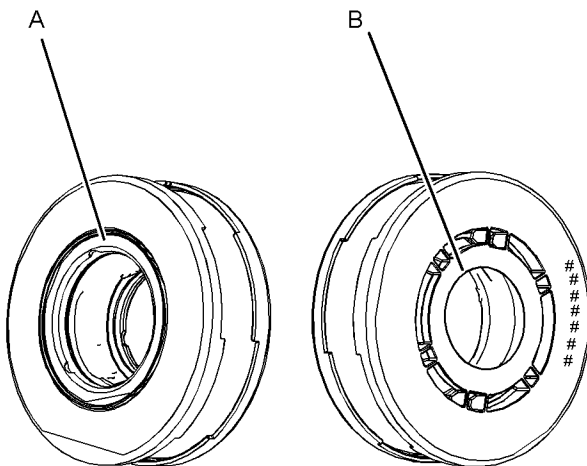

Illustration 58

g02827300

#### Typical example

(A) Diameter  
(B) Diameter

1. Install a new O ring seal (5) onto the cover (6).

**Note:** The breather element must have the correct orientation before installation. Diameter (A) is visibly larger than diameter (B).

2. Install diameter (A) of the breather element (3) onto the shaft (2). When correctly installed the part number of the breather element will be visible.
3. Install circlip (4) and cover (6). Install nuts (7) and tighten to 25 N·m (18 lb ft). If necessary, install breather pipes to cover.

4. Install the guard, refer to OEM.

i07819538

## Engine Mounts - Inspect

**Note:** The engine mounts may not have been supplied by Perkins. Refer to the Original Equipment Manufacturer (OEM information for further details on the engine mounts and the correct bolt torque.

Inspect the engine mounts for deterioration and for correct bolt torque. Excessive engine vibration can be caused by the following conditions:

- Incorrect mounting of the engine
- Deterioration of the engine mounts
- Loose engine mounts

Any engine mount that shows deterioration should be replaced. Refer to the OEM information for the recommended torques.

When the engine mounts are supplied by Perkins the maintenance procedure will be supplied in the Disassembly and Assembly manual for your engine.

i04728471

## Engine Oil Level - Check

### WARNING

Hot oil and hot components can cause personal injury. Do not allow hot oil or hot components to contact the skin.

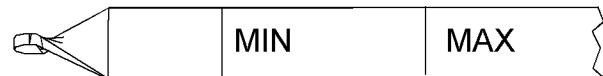

Illustration 59

g02829378

#### Typical example

**NOTICE**

Perform this maintenance with the engine stopped.

**Note:** Ensure that the engine is either level or that the engine is in the normal operating position in order to obtain a true level indication.

**Note:** After the engine has been switched OFF, wait for 10 minutes in order to allow the engine oil to drain to the oil pan before checking the oil level.

1. Maintain the oil level between the MIN mark and the mark MAX on the engine oil dipstick. Do not fill the crankcase above the MAX mark.

**NOTICE**

Operating your engine when the oil level is above the MAX mark could cause your crankshaft to dip into the oil. The air bubbles created from the crankshaft dipping into the oil reduces the oils lubricating characteristics and could result in the loss of power.

2. Remove the oil filler cap and add oil, if necessary. Clean the oil filler cap. Install the oil filler cap.

If an increase in the oil level is noticed, refer to Troubleshooting, "Oil Contains Fuel".

i01907674

## Engine Oil Sample - Obtain

The condition of the engine lubricating oil may be checked at regular intervals as part of a preventive maintenance program. Perkins include an oil sampling valve as an option. The oil sampling valve (if equipped is included in order to regularly sample the engine lubricating oil. The oil sampling valve is positioned on the oil filter head or the oil sampling valve is positioned on the cylinder block.

Perkins recommends using a sampling valve in order to obtain oil samples. The quality and the consistency of the samples are better when a sampling valve is used. The location of the sampling valve allows oil that is flowing under pressure to be obtained during normal engine operation.

### Obtain the Sample and the Analysis

**WARNING**

**Hot oil and hot components can cause personal injury. Do not allow hot oil or hot components to contact the skin.**

In order to help obtain the most accurate analysis, record the following information before an oil sample is taken:

- The date of the sample
- Engine model
- Engine number
- Service hours on the engine
- The number of hours that have accumulated since the last oil change
- The amount of oil that has been added since the last oil change

Ensure that the container for the sample is clean and dry. Also ensure that the container for the sample is clearly labelled.

To ensure that the sample is representative of the oil in the crankcase, obtain a warm, well mixed oil sample.

To avoid contamination of the oil samples, the tools and the supplies that are used for obtaining oil samples must be clean.

The sample can be checked for the following: the quality of the oil, the existence of any coolant in the oil, the existence of any ferrous metal particles in the oil and the existence of any nonferrous metal particles in the oil.

i06707128

## Engine Oil and Filter - Change

**WARNING**

**Hot oil and hot components can cause personal injury. Do not allow hot oil or hot components to contact the skin.**

**NOTICE**

Care must be taken to ensure that fluids are contained during performance of inspection, maintenance, testing, adjusting and repair of the product. Be prepared to collect the fluid with suitable containers before opening any compartment or disassembling any component containing fluids.

Dispose of all fluids according to local regulations and mandates.

Maintenance Section  
Engine Oil and Filter - Change

---

**NOTICE**

Keep all parts clean from contaminants.

Contaminants may cause rapid wear and shortened component life.

The engine oil service reset procedure must be completed after the engine oil, and filter have been changed. Refer to "Engine Oil Service Reset" for more information.

Do not drain the engine lubricating oil when the engine is cold. As the engine lubricating oil cools, suspended waste particles settle on the bottom of the oil pan. The waste particles are not removed with draining cold oil. Drain the oil pan with the engine stopped. Drain the oil pan with the oil warm. This draining method allows the waste particles that are suspended in the oil to be drained properly.

Failure to follow this recommended procedure will cause the waste particles to be recirculated through the engine lubrication system with the new oil.

## Drain the Engine Lubricating Oil

Ensure that the vessel that will be used is large enough to collect the waste oil. After the engine has been run at the normal operating temperature, stop the engine. Ensure that the application that the engine is installed is on level ground. Use one of the following methods to drain the engine oil pan:

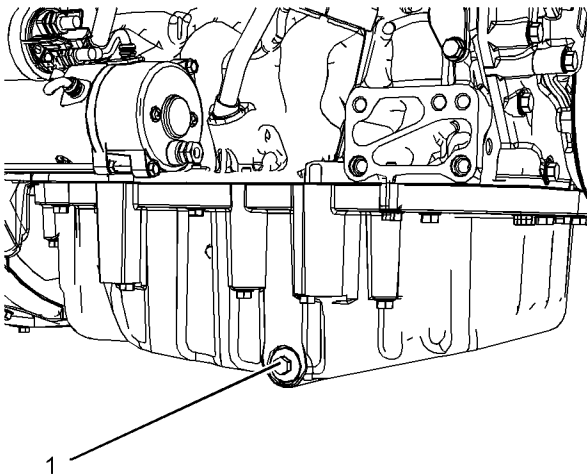

Illustration 60

g02519103

Typical example

- If the engine is equipped with a drain valve, turn the drain valve knob counterclockwise to drain the oil. After the oil has drained, turn the drain valve knob clockwise to close the drain valve.

- If the engine is not equipped with a drain valve, remove the oil drain plug (1) to allow the oil to drain. If the engine is equipped with a shallow oil pan, remove the bottom oil drain plugs from both ends of the oil pan.

After the oil has drained, replace the drain plug. If necessary replace the seal on the drain plug. Install drain plug and tighten to 34 N·m (25 lb ft).

## Replace the Oil Filter

---

**NOTICE**

Perkins oil filters are manufactured to Perkins specifications. Use of an oil filter that is not recommended by Perkins could result in severe damage to the engine bearings, crankshaft, as a result of the larger waste particles from unfiltered oil entering the engine lubricating system. Only use oil filters recommended by Perkins.

1. Using a suitable tool, remove the engine oil filter.

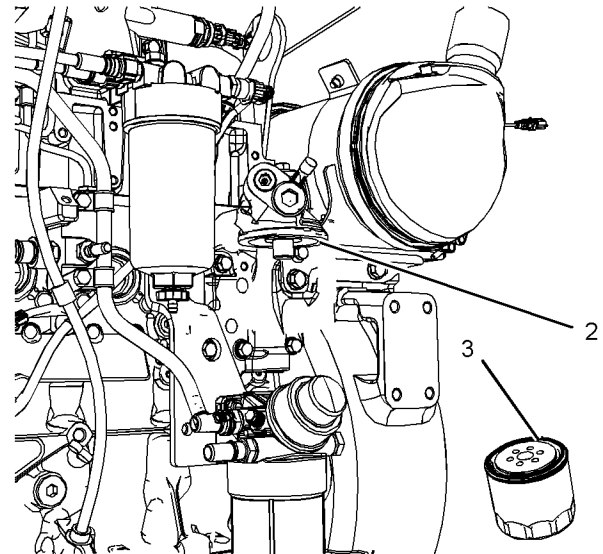

Illustration 61

g02516777

Typical example

2. Clean sealing surface (2).
3. Apply clean engine oil to O ring seal (3) on the new oil filter.

---

**NOTICE**

Do not fill the oil filters with oil before installing them. This oil would not be filtered and could be contaminated. Contaminated oil can cause accelerated wear to engine components or engine damage.

---



4. Install the engine oil filter, spin on the oil filter until the O ring seal contacts the oil filter base. Then, rotate the oil filter  $\frac{3}{4}$  of a full turn, by hand only.

### Vertically Up Oil Filter

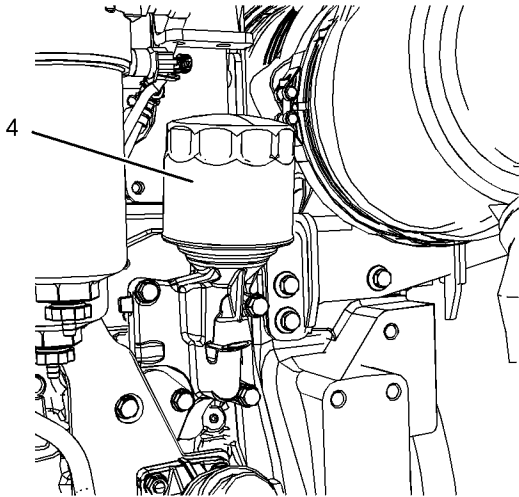

Illustration 62

g02596778

(4) Vertically up oil filter

Some oil filters may be installed vertically up. Use the same procedure to replace the oil filter. Ensure that all the oil has drained from the filter before removal.

### Fill the Oil Pan

1. Remove the oil filler cap. Refer to this Operation and Maintenance Manual, "Fluid Recommendations" for more information on suitable oils. Fill the oil pan with the correct amount of new engine lubricating oil. Refer to this Operation and Maintenance Manual, "Refill Capacities" for more information on refill capacities.

#### NOTICE

If equipped with an auxiliary oil filter system or a remote filter system, follow the OEM or the filter manufacturer's recommendations. Under filling or over filling the crankcase with oil can cause engine damage.

2. Start the engine and run the engine at "LOW IDLE" for 2 minutes. Perform this procedure to ensure that the lubrication system has oil and that the oil filters are filled. Inspect the oil filter for oil leaks.
3. Stop the engine and allow the oil to drain back to the oil pan for a minimum of 10 minutes.



Illustration 63

g02829378

4. Remove the engine oil level gauge to check the oil level. Maintain the oil level between the MIN mark and MAX mark on the engine oil level gauge. Do not fill the crankcase above the MAX mark.

### Engine Oil Service Reset

#### NOTICE

Failure to perform a schedule oil and filter service with an engine oil service reset will trigger an engine derate.

The low oil warning lamp has two functions. The lamp on solid will indicate that the engine has low oil pressure. The lamp flashing will indicate the engine oil and filter **MUST** be changed and the engine oil service reset **MUST** be completed. The lamp will only flash with the key in the ON position, with the engine in operation the lamp will be extinguished.

**Note:** If the engine oil and filter have been changed before the warning lamp has started to flash, the engine oil service reset procedure **MUST** still be completed. Upon completion of the reset procedure, the lamp will flash three times.

Some applications may have other methods to perform an engine oil service reset. For assistance with the engine oil service reset contact your Perkins distributor, or your OEM.

Use one of the following procedures after the engine oil and filter has been changed to complete an engine oil service reset:

## Throttle Control Option

**Note:** Some application the maximum throttle position can before the throttle peddle has reached the stop. The actual maximum position of the throttle must be known before starting the procedure. With the known maximum position the middle position of the throttle can be calculated. The throttle must be positioned in the required positions for the prescribed period to perform an engine oil service reset.

1. With the engine stopped. Turn the keyswitch to the ON position, and wait 15 seconds, but not more than 20 seconds. Go to step 2.
2. Move the throttle to the maximum position for more than 15 seconds, but less than 20 seconds.
3. Return throttle to zero position for more than 15 seconds, but less than 20 seconds.
4. Move the throttle to the maximum position for more than 15 seconds, but less than 20 seconds.
5. Return throttle to zero position for more than 15 seconds, but less than 20 seconds.
6. Move the throttle to the middle position for more than 15 seconds, but less than 20 seconds. Return the throttle to zero position. The engine oil service reset procedure is complete.
7. On completion of the sequence, the low oil warning lamp will flash three times. Each flash will be for 1 second with a 1 second interval. This sequence of flashes indicates that the warning lamp has been reset and the engine can be started and operated normally.
8. Turn the keyswitch to the OFF position.
9. If the procedure has been interrupted before completion, turn the power off for 20 seconds before starting again.

## Multi-State Switch Option

1. With the engine stopped. Turn the keyswitch to the ON position, and wait 15 seconds, but not more than 20 seconds. Go to step 2.
2. Turn the multi-state switch to position 1 for more than 15 seconds, but less than 20 seconds.
3. Return the multi-state switch to position 0 for more than 15 seconds, but less than 20 seconds.
4. Turn the multi-state switch to position 1 for more than 15 seconds, but less than 20 seconds.
5. Return the multi-state switch to position 0 for more than 15 seconds, but less than 20 seconds

6. Turn the multi-state switch to position 1 for more than 15 seconds, but less than 20 seconds. Return the multi-state switch to position 0. The engine oil service reset procedure is complete.
7. On completion of the sequence, the low oil warning lamp will flash three times. Each flash will be for 1 second with a 1 second interval. This sequence of flashes indicates that the warning lamp has been reset and the engine can be started and operated normally.
8. Turn the keyswitch to the OFF position.
9. If the procedure has been interrupted before completion, turn the power off for 20 seconds before starting again.

## Perkins Electronic Service Tool

The Perkins electronic service tool can be used to reset the oil service indicator. Connect the electronic service tool and use the menu to reset the oil service reset procedure.

i04401341

## Fan Clearance - Check

There are different types of cooling systems. Refer to the OEM for information on clearance for the fan.

Ensure that the engine is stopped. Ensure that the battery disconnect switch is in the OFF position. Ensure that the cooling system is full. The clearance between the cover (1) and the fan (2) will require checking. The gap (A) between the edge of the cover and the tip of the fan blade must be checked in four equally spaced positions.

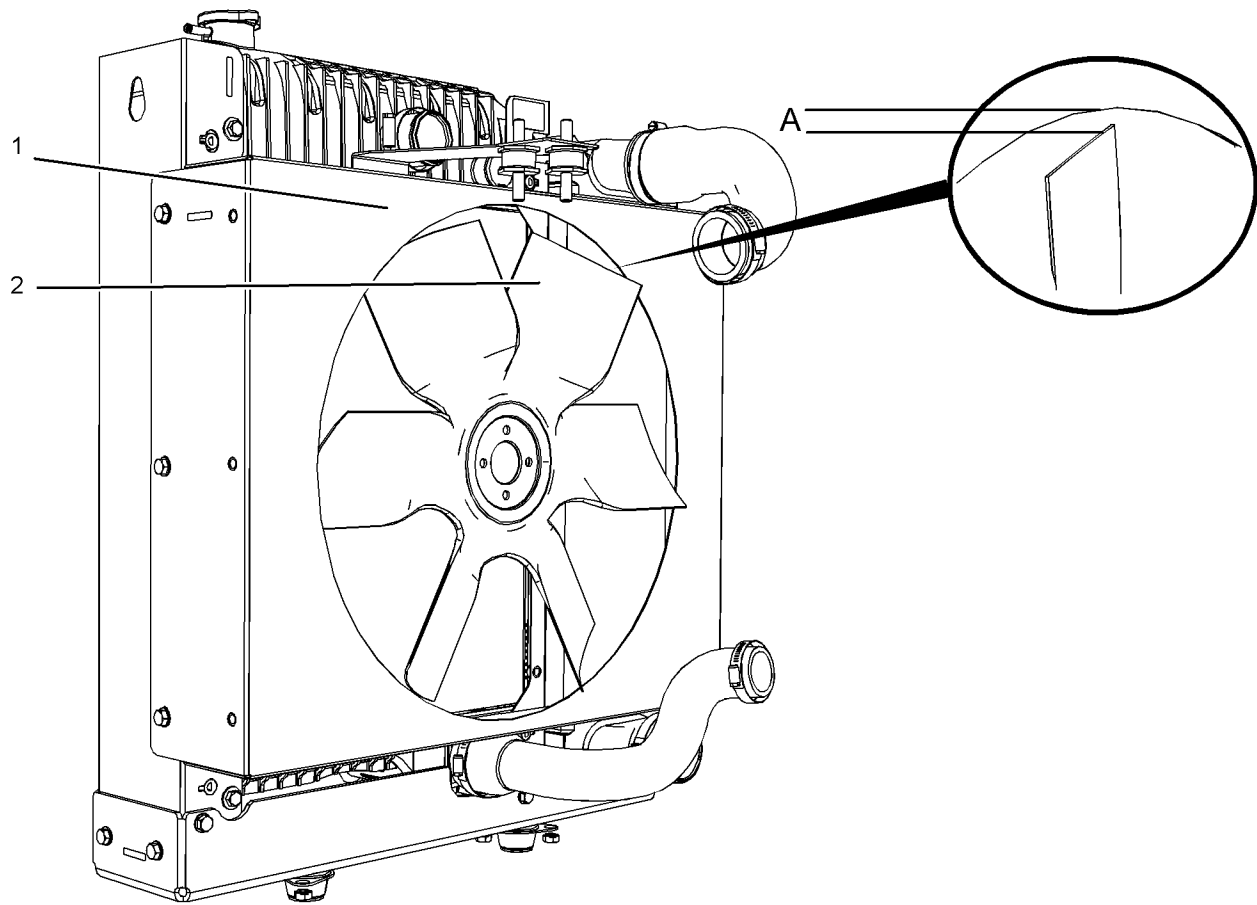

Illustration 64

g02585058

### Typical example

Adjustment of the cover will change the clearance (gap) between the edge of the cover and the tip of the fan blade. Ensure that the cover is centralized to the fan.

The clearance (A) must be set to  $10 \pm 1$  mm ( $0.39370 \pm 0.03937$  inch).

i04366913

## Fuel System - Prime

**Note: Refer to Systems Operation, Testing, and Adjusting, "Cleanliness of Fuel System Components" for detailed information on the standards of cleanliness that must be observed during ALL work on the fuel system.**

Ensure that all adjustments and repairs are performed by authorized personnel that have had the correct training.

### NOTICE

Do not crank the engine continuously for more than 30 seconds. Allow the starting motor to cool for two minutes before cranking the engine again.

If air enters the fuel system, the air must be purged from the fuel system before the engine can be started. Air can enter the fuel system when the following events occur:

- The fuel tank is empty or the fuel tank has been partially drained.
- The low-pressure fuel lines are disconnected.
- A leak exists in the low-pressure fuel system.
- The fuel filter has been replaced.

Use the following procedures in order to remove air from the fuel system:

Maintenance Section  
Fuel System Primary Filter (Water Separator) Element - Replace

1. Ensure that the fuel system is in working order.  
Check that the fuel supply valve (if equipped) is in the "ON" position.
  2. Operate the hand priming pump. Count the number of operations of the pump. After approximately 80 depression of the pump stop.
- Note:** As the fuel system is primed, the pressure will increase within the fuel system and this increase in pressure can be felt during priming.
3. The fuel system should now be primed and the engine should be able to start.
  4. Operate the engine starter and crank the engine.  
After the engine has started, operate the engine at low idle for a minimum of 5 minutes. Ensure that the fuel system is free from leaks.

**Note:** Operating the engine for this period will help ensure that the fuel system is free of air. **DO NOT loosen the high-pressure fuel lines in order to purge air from the fuel system. This procedure is not required.**

After the engine has stopped, you must wait for 10 minutes in order to allow the fuel pressure to be purged from the high-pressure fuel lines before any service or repair is performed on the engine fuel lines. If necessary, perform minor adjustments. Repair any leaks from the low-pressure fuel system and from the cooling, lubrication, or air systems. Replace any high-pressure fuel line that has leaked. Refer to Disassembly and Assembly Manual, "Fuel Injection Lines - Install".

If you inspect the engine in operation, always use the proper inspection procedure in order to avoid a fluid penetration hazard. Refer to Operation and Maintenance Manual, "General hazard Information".

If the engine will not start, refer to Troubleshooting, "Engine Cranks but will not Start".

i05326388

## Fuel System Primary Filter (Water Separator Element - Replace

### WARNING

**Fuel leaked or spilled onto hot surfaces or electrical components can cause a fire. To help prevent possible injury, turn the start switch off when changing fuel filters or water separator elements. Clean up fuel spills immediately.**

**Note: Refer to Systems Operation, Testing, and Adjusting, "Cleanliness of Fuel System Components" for detailed information on the standards of cleanliness that must be observed during ALL work on the fuel system.**

#### NOTICE

Ensure that the engine is stopped before any servicing or repair is performed.

## Remove the Element

1. Turn the fuel supply valve (if equipped) to the OFF position before performing this maintenance.
2. Place a suitable container under the water separator in order to catch any fuel that might spill. Clean up any spilled fuel. Clean the outside body of the filter assembly.
3. Make a temporary Mark (A) across the filter before the assembly is removed.

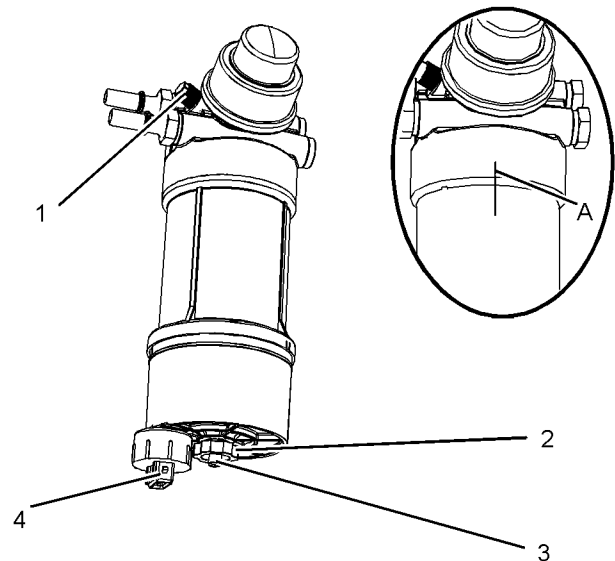

Illustration 65

g03374220

Typical example

4. Install a suitable tube onto drain (3). Open the drain valve (2). Rotate the drain valve counterclockwise. Two full turns are required. Loosen vent screw (1).

**Note:** Two complete rotations of the valve will release the valve from the filter element.

5. Allow the fuel to drain into the container. Remove the tube and install the valve into the filter element. Engage the threads of the valve into the filter element. Do not secure the valve.

6. Tighten the vent screw (1) securely . Remove the wiring harness from connection (4).

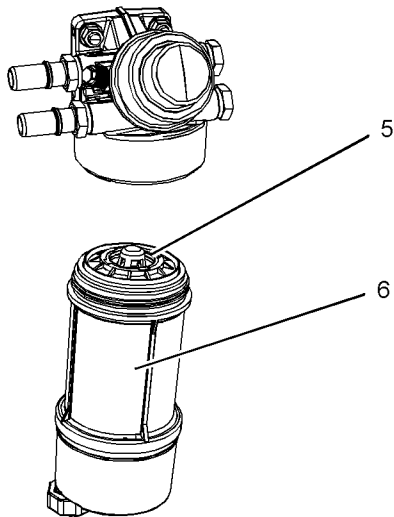

Illustration 66

g03374223

Typical example

7. Using a suitable tool, remove the filter bowl (6). Rotate the filter assembly counterclockwise in order to remove the filter assembly. Use a suitable tool in order to remove the filter assembly.

8. Rotate the filter element counterclockwise and remove the filter element (5). Clean the filter bowl.

## Install the Element

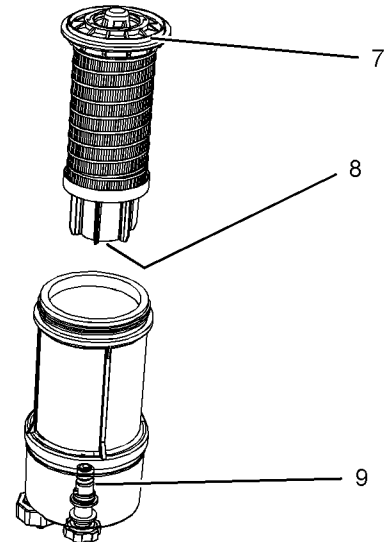

Illustration 67

g03374224

Typical example

1. Locate the thread in the filter element (8) onto the threads (9). Spin on the element. Do not tighten.
2. Lubricate the O ring seal (7) with clean engine oil. Do NOT fill the bowl with fuel before the assembly is installed.
3. Do NOT use a tool in order to install the filter assembly. Tighten the filter bowl (6) by hand. Install the filter bowl (6) and align with your temporary marks (A).
4. Tighten the valve (2) securely. Remove the container and dispose of the fuel in a safe place.

5. The secondary filter element must be replaced at the same time as the primary filter element. Refer to the Operation and Maintenance Manual , "Fuel System Filter - Replace".

i05326334

## Fuel System Primary Filter/ Water Separator - Drain

### WARNING

Fuel leaked or spilled onto hot surfaces or electrical components can cause a fire. To help prevent possible injury, turn the start switch off when changing fuel filters or water separator elements. Clean up fuel spills immediately.

### NOTICE

Ensure that the engine is stopped before any servicing or repair is performed.

### NOTICE

The water separator can be under suction during normal engine operation. Ensure that the drain valve is tightened securely to help prevent air from entering the fuel system.

1. Place a suitable container under the water separator in order to catch any fluid that might spill. Clean up any spilled fluid.
2. Ensure that the outer body of the filter assembly is clean and free from dirt.

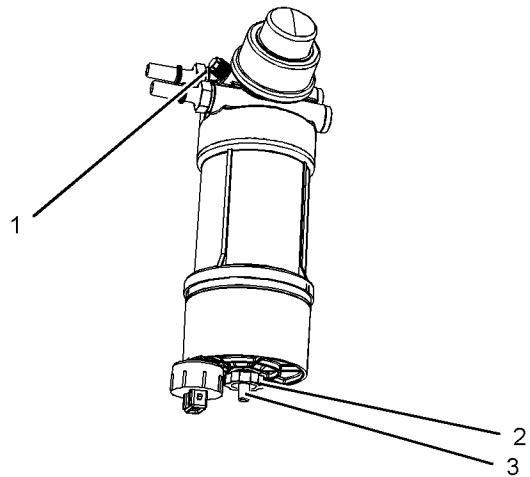

Illustration 68

g03374226

Typical example

3. Install a suitable tube onto drain (3). Open the drain valve (2). Rotate the drain valve counterclockwise. Two full turns are required. Loosen vent screw (1).

**Note:** Two complete rotations of the valve will release the valve from the filter element.

4. Allow the fluid to drain into the container.
5. Engage the threads of the valve into the filter element and tighten the drain valve by hand pressure only. Tighten vent screw securely.
6. Remove the tube and remove the container.

i04367528

## Fuel System Secondary Filter - Replace

### WARNING

Fuel leaked or spilled onto hot surfaces or electrical components can cause a fire. To help prevent possible injury, turn the start switch off when changing fuel filters or water separator elements. Clean up fuel spills immediately.

### NOTICE

Ensure that the engine is stopped before any servicing or repair is performed.

Refer to **Systems Operation, Testing, and Adjusting, "Cleanliness of Fuel System Components"** for detailed information on the standards of cleanliness that must be observed during ALL work on the fuel system.

## Remove the Element

1. Turn the fuel supply valve (if equipped) to the OFF position before performing this maintenance.
2. Place a suitable container under the fuel filter in order to catch any fuel that might spill. Clean up any spilled fuel. Clean the outside body of the filter assembly.

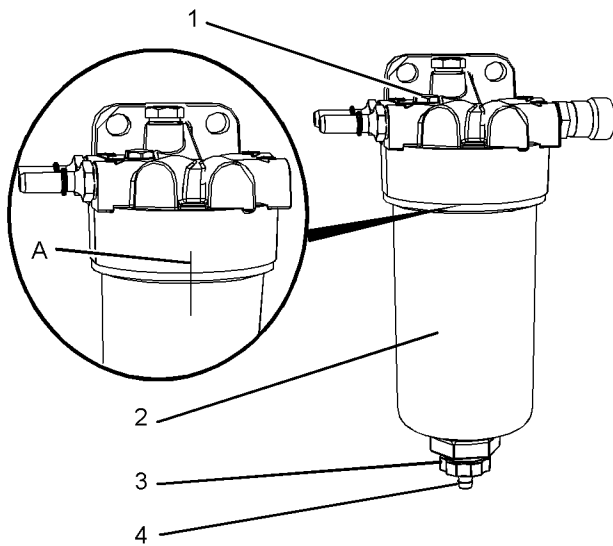

Illustration 69

g02522536

Typical example

3. Make a temporary Mark (A) across the filter before the assembly is removed. Install a suitable tube onto drain (4). Open the drain valve (3). Rotate the drain valve counterclockwise. Two full turns are required. Loosen vent screw (1).

**Note:** Two complete rotations of the valve will release the valve from the filter element.

4. Allow the fuel to drain into the container. Remove the tube and install the valve into the filter element. Engage the threads of the valve into the filter element. Do not secure the valve.
5. Tighten the vent screw (1) securely.
6. Remove the filter bowl (2). Rotate the filter assembly counterclockwise in order to remove the assembly. Use a suitable tool in order to remove the filter bowl.

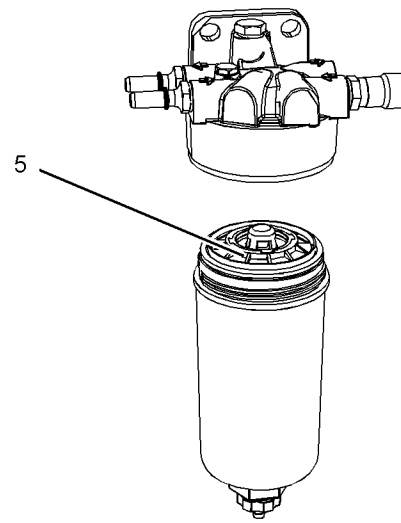

Illustration 70

g02522538

Typical example

7. Rotate the filter element counterclockwise and remove the filter element (5). Clean the filter bowl.

## Install the Element

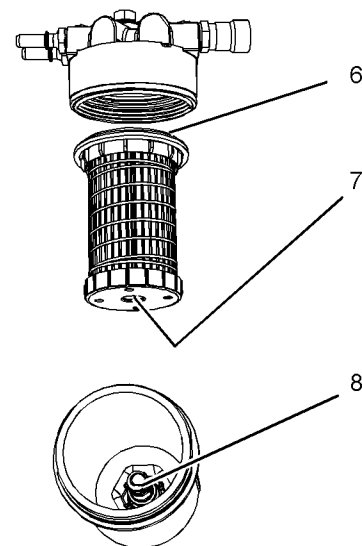

Illustration 71

g02522540

Typical example

1. Locate the thread in the filter element (7) onto the threads (8). Spin on the element. Do not tighten.

2. Lubricate the O ring seal (6) with clean engine oil. Do NOT fill the filter bowl (2) with fuel before the filter assembly is installed.
3. Do not use a tool in order to install the filter assembly. Tighten the assembly by hand. Install the filter bowl (2) and align with your temporary Marks.
4. Tighten the drain valve (3). Turn the fuel supply valve to the ON position.
5. The Primary filter element must be replaced at the same time as the secondary filter element. Refer to the Operation and Maintenance Manual , “Fuel System Primary Filter (Water Separator) Element - Replace”.
6. Prime the fuel system. Refer to the Operation and Maintenance Manual, “Fuel System - Prime” for more information.

i02348492

## Fuel Tank Water and Sediment - Drain

---

### NOTICE

Care must be taken to ensure that fluids are contained during performance of inspection, maintenance, testing, adjusting and repair of the product. Be prepared to collect the fluid with suitable containers before opening any compartment or disassembling any component containing fluids.

Dispose of all fluids according to local regulations and mandates.

---

## Fuel Tank

Fuel quality is critical to the performance and to the service life of the engine. Water in the fuel can cause excessive wear to the fuel system.

Water can be introduced into the fuel tank when the fuel tank is being filled.

Condensation occurs during the heating and cooling of fuel. The condensation occurs as the fuel passes through the fuel system and the fuel returns to the fuel tank. This causes water to accumulate in fuel tanks. Draining the fuel tank regularly and obtaining fuel from reliable sources can help to eliminate water in the fuel.

## Drain the Water and the Sediment

Fuel tanks should contain some provision for draining water and draining sediment from the bottom of the fuel tanks.

Open the drain valve on the bottom of the fuel tank in order to drain the water and the sediment. Close the drain valve.

Check the fuel daily. Allow five minutes after the fuel tank has been filled before draining water and sediment from the fuel tank.

Fill the fuel tank after operating the engine in order to drive out moist air. This will help prevent condensation. Do not fill the tank to the top. The fuel expands as the fuel gets warm. The tank may overflow.

Some fuel tanks use supply pipes that allow water and sediment to settle below the end of the fuel supply pipe. Some fuel tanks use supply lines that take fuel directly from the bottom of the tank. If the engine is equipped with this system, regular maintenance of the fuel system filter is important.

## Fuel Storage Tanks

Drain the water and the sediment from the fuel storage tank at the following intervals:

- Weekly
- Service intervals
- Refill of the tank

This will help prevent water or sediment from being pumped from the storage tank into the engine fuel tank.

If a bulk storage tank has been refilled or moved recently, allow adequate time for the sediment to settle before filling the engine fuel tank. Internal baffles in the bulk storage tank will also help trap sediment. Filtering fuel that is pumped from the storage tank helps to ensure the quality of the fuel. When possible, water separators should be used.

i07819616

## Hoses and Clamps - Inspect/ Replace

### WARNING

**Contact with high pressure fuel may cause fluid penetration and burn hazards. High pressure fuel spray may cause a fire hazard. Failure to follow these inspection, maintenance and service instructions may cause personal injury or death.**

---

If you inspect the engine in operation, always use the proper inspection procedure to avoid a fluid penetration hazard. Refer to Operation and Maintenance Manual, “General hazard Information” and Operation and Maintenance Manual, “High Pressure Fuel Lines” for the correct procedures.



Inspect all hoses for leaks that are caused by the following conditions:

- Cracking
- Softness
- Loose clamps

Replace hoses that are cracked or soft. Tighten any loose clamps.

Check for the following conditions:

- End fittings that are damaged or leaking
- Outer covering that is chafed or cut
- Exposed wire that is used for reinforcement
- Outer covering that is ballooning locally
- Flexible part of the hose that is kinked or crushed
- Armoring that is embedded in the outer covering

A constant torque hose clamp can be used in place of any standard hose clamp. Ensure that the constant torque hose clamp is the same size as the standard clamp.

Due to extreme temperature changes, the hose will harden. Hardening of the hoses will cause hose clamps to loosen. This can result in leaks. A constant torque hose clamp will help to prevent loose hose clamps.

Each installation application can be different. The differences depend on the following factors:

- Type of hose
- Type of fitting material
- Anticipated expansion and contraction of the hose
- Anticipated expansion and contraction of the fittings

## Replace the Hoses and the Clamps

Refer to the OEM information for further information on removing and replacing fuel hoses (if equipped).

The following text describes a typical method of replacing coolant hoses. Refer to the OEM information for further information on the coolant system and the hoses for the coolant system.

### **WARNING**

**Pressurized System: Hot coolant can cause serious burns. To open the cooling system filler cap, stop the engine and wait until the cooling system components are cool. Loosen the cooling system pressure cap slowly in order to relieve the pressure.**

1. Stop the engine. Allow the engine to cool.
2. Loosen the cooling system filler cap slowly to relieve any pressure. Remove the cooling system filler cap.

**Note:** Drain the coolant into a suitable, clean container. The coolant can be reused.

3. Drain the coolant from the cooling system to a level that is below the hose that is being replaced.
4. Remove the hose clamps.
5. Disconnect the old hose.
6. Replace the old hose with a new hose.
7. Install the hose clamps with a torque wrench.

**Note:** For the correct coolant, see this Operation and Maintenance Manual, "Fluid Recommendations".

8. Refill the cooling system. Refer to the OEM information for further information on refilling the cooling system.
9. Clean the cooling system filler cap. Inspect the cooling system filler cap's seals. Replace the cooling system filler cap if the seals are damaged. Install the cooling system filler cap.

10. Start the engine. Inspect the cooling system for leaks.

i05324852

## Oxygen Sensor - Replace

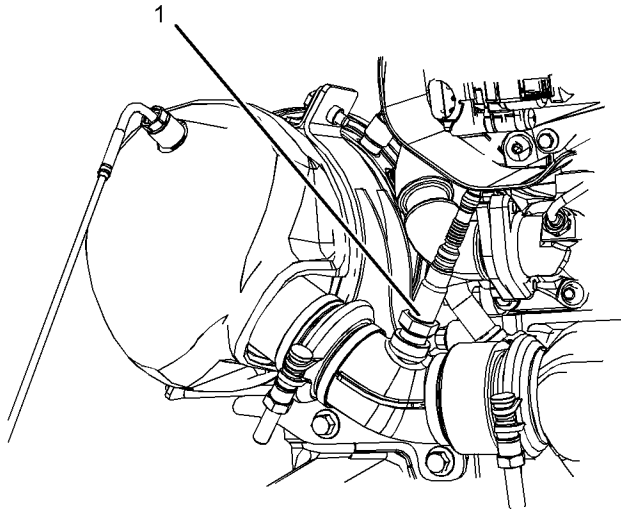

Illustration 72

g03373217

### Typical example

The oxygen sensor (1) must be replaced at 3000 hours. Refer to the Disassembly and Assembly, "Oxygen Sensor - Remove and Install" for the procedure.

The electronic service tool will be required in order to perform a reset after a new oxygen sensor is installed.

i04245214

## Radiator - Clean

The radiator is not usually supplied by Perkins. The following text describes a typical cleaning procedure for the radiator. Refer to the OEM information for further information on cleaning the radiator.

**Note:** Some application will require a fuel cooler to be installed. The fuel cooler is a type of radiator that uses air to cool the fuel and the fuel cooler will require cleaning.

**Note:** Adjust the frequency of cleaning according to the effects of the operating environment.

Inspect the radiator for these items: Damaged fins, corrosion, dirt, grease, insects, leaves, oil and other debris. Clean the radiator, if necessary.

### WARNING

Personal injury can result from air pressure.

Personal injury can result without following proper procedure. When using pressure air, wear a protective face shield and protective clothing.

Maximum air pressure at the nozzle must be less than 205 kPa (30 psi) for cleaning purposes.

Pressurized air is the preferred method for removing loose debris. Direct the air in the opposite direction to the fans air flow. Hold the nozzle approximately 6 mm (0.25 inch) away from the radiator fins. Slowly move the air nozzle in a direction that is parallel with the radiator tube assembly. The pressurized air will remove debris that is between the tubes.

Pressurized water may also be used for cleaning. The maximum water pressure for cleaning purposes must be less than 275 kPa (40 psi). Use pressurized water in order to soften mud. Clean the core from both sides.

Use a degreaser and steam for removal of oil and grease. Clean both sides of the core. Wash the core with detergent and hot water. Thoroughly rinse the core with clean water.

If the radiator is blocked internally, refer to the OEM Manual for information regarding flushing the cooling system.

After cleaning the radiator, start the engine. Allow the engine to operate at low idle speed for 3 to 5 minutes. Accelerate the engine to high idle. The high idle speed will help in the removal of debris and the drying of the core. Slowly reduce the engine speed to low idle and then stop the engine. Use a light bulb behind the core in order to inspect the core for cleanliness. Repeat the cleaning, if necessary.

Inspect the fins for damage. Bent fins may be opened with a "comb". Inspect these items for good condition: Welds, mounting brackets, air lines, connections, clamps and seals. Make repairs, if necessary.

i03639888

i04407666

## Radiator Pressure Cap - Clean/Replace

### **WARNING**

**Pressurized System:** Hot coolant can cause serious burns. To open the cooling system filler cap, stop the engine and wait until the cooling system components are cool. Loosen the cooling system pressure cap slowly in order to relieve the pressure.

### NOTICE

When any servicing or repair of the engine cooling system is performed the procedure must be performed with the engine on level ground. This will allow you to accurately check the coolant level. This will also help in avoiding the risk of introducing an air lock into the coolant system.

1. Stop the engine and allow the engine to cool. Loosen the cooling system filler cap slowly in order to relieve any pressure. Remove the radiator pressure cap.
2. Check coolant level. Refer to Operation and Maintenance Manual, "Cooling System Coolant Level - Check".
3. Install new radiator pressure cap.

i07888480

## Starting Motor - Inspect

Perkins recommends a scheduled inspection of the starting motor. If the starting motor fails, the engine may not start in an emergency situation.

Check the starting motor for correct operation. Check the electrical connections and clean the electrical connections. Refer to the Systems Operation, Testing and Adjusting Manual, "Electric Starting System - Test" for more information on the checking procedure and for specifications consult your Perkins dealer or your Perkins distributor for assistance.

## Turbocharger - Inspect

### **WARNING**

Hot engine components can cause injury from burns. Before performing maintenance on the engine, allow the engine and the components to cool.

### NOTICE

Turbocharger bearing failures can cause large quantities of oil to enter the air intake and exhaust systems. Loss of engine lubricant can result in serious engine damage.

Minor leakage of oil into a turbocharger under extended low idle operation should not cause problems as long as a turbocharger bearing failure has not occurred.

When a turbocharger bearing failure is accompanied by a significant engine performance loss (exhaust smoke or engine rpm up at no load), do not continue engine operation until the turbocharger is renewed.

A visual inspection of the turbocharger can minimize unscheduled downtime. A visual inspection of the turbocharger can also reduce the chance for potential damage to other engine parts. Do not inspect the engine with the engine in operation.

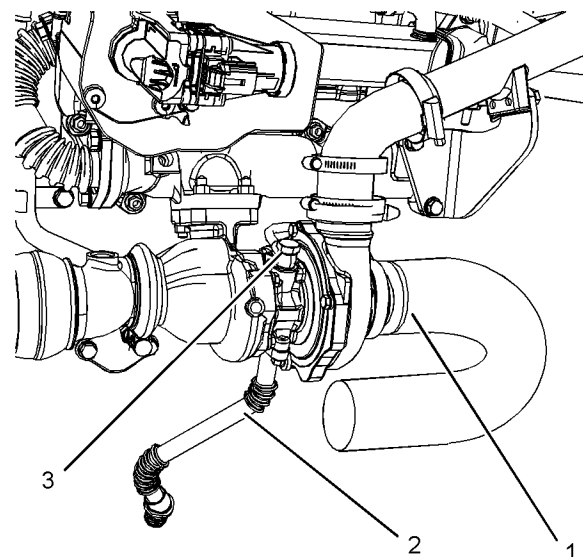

Illustration 73

g02603804

Typical example

1. Ensure that the turbocharger is clean and free from dirt before removing components for inspection.

2. Remove the air intake pipe (1). Visually inspect the piping for the presence of oil. A small amount of oil will be expected, this oil is due to the breather system design. Clean the interior of the pipe in order to prevent dirt from entering during reassembly.
3. Check for obvious heat discoloration of the turbocharger. Check for any loose bolts or any missing bolts. Check for damage to the oil supply line (3) and the oil drain line (2). Check for cracks in the housing of the turbocharger. Ensure that the compressor wheel can rotate freely. Check that there are no visual signs of damage to the compressor wheel.
4. Check for the presence of oil. If oil is leaking from the back side of the compressor wheel, there is a possibility of a failed turbocharger oil seal.  
  
The presence of oil may be the result of extended engine operation at low idle. The presence of oil may also be the result of a restriction of the line for the intake air (clogged air filters). A restriction can cause the turbocharger to slobber.
5. Install the air intake pipe to the turbocharger housing. Ensure that all clamps are installed correctly and that all clamps are tightened securely. For more information, refer to Systems Operation, Testing, and Adjusting, "Turbocharger - Inspect".

i04367583

## Walk-Around Inspection

### Inspect the Engine for Leaks and for Loose Connections

A walk-around inspection should only take a few minutes. When the time is taken to perform these checks, costly repairs and accidents can be avoided.

For maximum engine service life, make a thorough inspection of the engine compartment before starting the engine. Look for items such as oil leaks or coolant leaks, loose bolts, worn belts, loose connections, and trash buildup. Make repairs, as needed:

- The guards must be in the correct place. Repair damaged guards or replace missing guards.
- Wipe all caps and plugs before the engine is serviced in order to reduce the chance of system contamination.

---

#### NOTICE

For any type of leak (coolant, lube, or fuel) clean up the fluid. If leaking is observed, find the source and correct the leak. If leaking is suspected, check the fluid levels more often than recommended until the leak is found or fixed, or until the suspicion of a leak is proved to be unwarranted.

---



---

#### NOTICE

Accumulated grease and/or oil on an engine is a fire hazard. Remove the accumulated grease and oil. Refer to this Operation and Maintenance Manual, "Engine - Clean" for more information.

---

- Ensure that the cooling system hoses are correctly clamped and that the cooling system hoses are tight. Check for leaks. Check the condition of all pipes.

- Inspect the water pump for coolant leaks.

**Note:** The water pump seal is lubricated by the coolant in the cooling system. It is normal for a small amount of leakage to occur as the engine cools down and the parts contract.

Excessive coolant leakage may indicate the need to replace the water pump. Remove the water pump. Refer to Disassembly and Assembly, "Water Pump - Remove and Install". For more information, consult your Perkins dealer or your Perkins distributor.

- Inspect the lubrication system for leaks at the front crankshaft seal, the rear crankshaft seal, the oil pan, the oil filters, and the rocker cover.
- Inspect the piping for the air intake system and the elbows for cracks and for loose clamps. Ensure that hoses and tubes are not contacting other hoses, tubes, wiring harnesses, etc.
- Ensure that the areas around the rotating parts are clear.
- Inspect the alternator belts and any accessory drive belts for cracks, breaks, or other damage.
- Inspect the wiring harness for damage.

Belts for multiple groove pulleys must be replaced as matched sets. If only one belt is replaced, the belt will carry more load than the belts that are not replaced. The older belts are stretched. The additional load on the new belt could cause the belt to break.

## High Pressure Fuel Lines

### WARNING

**Contact with high pressure fuel may cause fluid penetration and burn hazards. High pressure fuel spray may cause a fire hazard. Failure to follow these inspection, maintenance and service instructions may cause personal injury or death.**

After the engine has stopped, you must wait for 10 minutes in order to allow the fuel pressure to be purged from the high-pressure fuel lines before any service or repair is performed on the engine fuel lines. If necessary, perform minor adjustments. Repair any leaks from the low-pressure fuel system and from the cooling, lubrication, or air systems. Replace any high-pressure fuel line that has leaked. Refer to Disassembly and Assembly Manual, "Fuel Injection Lines - Install".

If you inspect the engine in operation, always use the proper inspection procedure in order to avoid a fluid penetration hazard. Refer to Operation and Maintenance Manual, "General hazard Information".

Visually inspect the high-pressure fuel lines for damage or signs of fuel leakage. Replace any damaged high-pressure fuel lines or high-pressure fuel lines that have leaked.

Ensure that all clips on the high-pressure fuel lines are in place and that the clips are not loose.

- Inspect the rest of the fuel system for leaks. Look for loose fuel line clamps.
- Drain the water and the sediment from the fuel tank on a daily basis in order to ensure that only clean fuel enters the fuel system.
- Inspect the wiring and the wiring harnesses for loose connections and for worn wires or frayed wires. Check for any loose tie-wraps or missing tie-wraps.
- Inspect the ground strap for a good connection and for good condition.
- Disconnect any battery chargers that are not protected against the current drain of the starting motor. Check the condition and the electrolyte level of the batteries, unless the engine is equipped with a maintenance free battery.

- Check the condition of the gauges. Replace any gauges that are cracked. Replace any gauge that cannot be calibrated.

i04406817

## Water Pump - Inspect

A failed water pump may cause severe engine overheating problems that could result in the following conditions:

- Cracks in the cylinder head
- A piston seizure
- Other potential damage to the engine

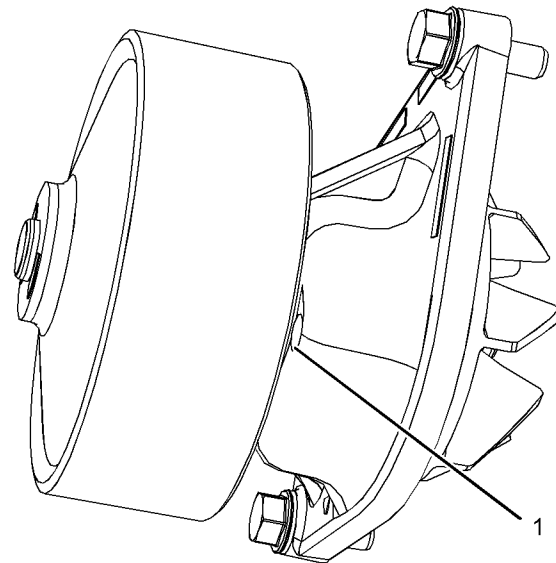

Illustration 74

g02601196

Typical example

(1) Weep hole

**Note:** The water pump seals are lubricated by the coolant in the cooling system.

Visually inspect the water pump for leaks.

**Note:** If engine coolant enters the engine lubricating system, the lubricating oil and the engine oil filter must be replaced. Draining will remove any contaminate and will prevent any irregular oil samples.

In order to install a new water pump, refer to the Disassembly and Assembly Manual, "Water Pump - Remove and Install".

## Warranty Section

### Warranty Information

i05328140

### Emissions Warranty Information

- EPA \_\_\_\_\_ United States Environmental Protection Agency
- CARB \_\_\_\_\_ California Air Resources Board

**Note:** The warranty of the engine applies to engines that are operated within the areas of the world where the following regulations apply: US EPA Tier 4 Interim, EU Stage IIIB or Japanese MLIT Step 4. If an engine is operated in regions of the world where these regulations do not apply the warranty will be void. Contact your Perkins dealer or your Perkins distributor for more information.

For a full warranty statement contact your Perkins dealer or your Perkins distributor. For customers that have a valid user name and password, for perkins.com. Login then go to TIPSS, and the warranty information can be accessed.

### Maintenance Recommendations

Efficiency of the emission control and the engine performance depends on adherence to proper operation and maintenance recommendations and use of recommended fuels and lubricating oils. According to recommendations, major adjustments and repairs should be made by your authorized Perkins distributor or your authorized Perkins dealer.

Various chemical fuel additives which claim to reduce visible smoke are available commercially. Although additives have been used to solve some isolated smoke problems in the field, additives are not recommended for general use. The engines should be certified without smoke depressants according to federal smoke regulations.

The aftertreatment system can be expected to function properly for the life-time of the engine (emissions durability period) subject to prescribed maintenance requirements being followed.

## Reference Information Section

www.perkins.com

---

NOTICE  
Dependant upon engine type and application.

---

## Reference Materials

i04224089

### Engine Protection Plans (Extended Service Contract)

Extended Service Contracts-purchased in minutes,  
protected for years.

Extended Service Contracts (ESC) protect you from the stress that unexpected repair work brings to your life by covering the cost of getting your engine up and running again. Unlike other extended warranties, Perkins Platinum ESC protects you against all component part failures.

Purchase peace of mind from only £0.03 / \$0.05 / euro 0.04 a day and let an ESC make your dreams a reality.

Why buy an Extended Service Contract?

1. No surprises - total protection from unexpected repair cost (parts, labor, and travel).
2. Enjoy longer lasting product support from Perkins global network.
3. Genuine Perkins parts ensure continued engine performance.
4. Highly trained technicians carry out all repairs.
5. Transferable coverage should you sell your machine.

Flexible coverage provides the right level of protection for your Perkins Engine. Coverage can be extended to 2 years/ 1,000 hours right up to 10 year/ 40,000

You can buy an ESC at any time during standard warranty - even the last day!

Each Perkins Distributor has highly trained and experienced Perkins Product Support Service Technicians. The Support Service are equipped, and available around the clock to get your engine running again with the minimum of downtime. Buying an ESC means that you get all this for free.

To purchase an Extended Service Contract, is quick and simple! Contact your local Perkins Distributor now and the distributor can provide you with a quote in minutes. You can locate your nearest Perkins Distributor by visiting:

# Index

## A

After Starting Engine .....	58
After Stopping Engine .....	68
Aftercooler Core - Clean/Test (Air-To-Air Aftercooler) .....	90
Aftercooler Core - Inspect .....	90
Alarms and Shutoffs .....	36
Alternator - Inspect .....	90
Alternator and Fan Belts - Replace .....	90

## B

Battery - Replace .....	91
Battery Electrolyte Level - Check .....	92
Battery or Battery Cable - Disconnect .....	92
Before Starting Engine .....	16, 56
Burn Prevention .....	11
Aftertreatment System .....	12
Batteries .....	12
Coolant .....	11
Diesel Fuel .....	12
Induction System .....	11
Oils .....	12

## C

Cold Weather Operation .....	64
Hints for Cold Weather Operation .....	64
Idling the Engine .....	65
Recommendations for Coolant Warm Up .....	65
Recommendations for the Coolant .....	64
Viscosity of the Engine Lubrication Oil .....	64
Cold Weather Starting .....	56
Configuration Parameters .....	53
Customer Specified Parameters .....	53
System Configuration Parameters .....	53
Coolant (Commercial Heavy-Duty) - Change .....	93
Drain .....	93
Fill .....	94
Flush .....	93
Coolant (ELC) - Change .....	94
Drain .....	95
Fill .....	96
Flush .....	96
Coolant Extender (ELC) - Add .....	96
Coolant Level - Check .....	97
Engines With a Coolant Recovery Tank .....	97

Engines Without a Coolant Recovery Tank .....	97
Cooling System Supplemental Coolant Additive (SCA) - Test/Add .....	98
Add the SCA, If Necessary .....	98
Test for SCA Concentration .....	98
Crushing Prevention and Cutting Prevention ..	14

## D

Diagnostic Lamp .....	52
Diesel Particulate Filter - Clean .....	99
Diesel Particulate Filter Regeneration .....	60
Modes of Regeneration .....	61
Regeneration .....	60
Regeneration Indicators .....	61
Regeneration Switch .....	61
Regeneration System Warning Indicators ..	61
Driven Equipment - Check .....	99

## E

Electrical System .....	17
Grounding Practices .....	17
Emergency Stopping .....	68
Emissions Certification Film .....	32
Emissions Warranty Information .....	118
Maintenance Recommendations .....	118
Engine - Clean .....	99
Aftertreatment .....	100
Engine Air Cleaner Element (Single Element) - Inspect/Clean/Replace .....	100
Engine Air Cleaner Service Indicator - Inspect .....	100
Test the Service Indicator .....	100
Engine Air Precleaner - Check/Clean (If Equipped) .....	101
Engine Crankcase Breather Element - Replace .....	101
Engine Breather .....	101
Engine Diagnostics .....	52
Engine Electronics .....	18
Engine Mounts - Inspect .....	102
Engine Oil and Filter - Change .....	103
Drain the Engine Lubricating Oil .....	104
Engine Oil Service Reset .....	105
Fill the Oil Pan .....	105
Perkins Electronic Service Tool .....	106
Replace the Oil Filter .....	104



Engine Oil Level - Check.....	102	Fuel System Primary Filter (Water Separator) Element - Replace.....	108
Engine Oil Sample - Obtain.....	103	Install the Element.....	109
Obtain the Sample and the Analysis.....	103	Remove the Element.....	108
Engine Operation.....	60	Fuel System Primary Filter/Water Separator - Drain.....	110
System Check.....	60	Fuel System Secondary Filter - Replace.....	110
Engine Operation with Active Diagnostic Codes.....	52	Install the Element.....	111
Engine Operation with Intermittent Diagnostic Codes.....	52	Remove the Element.....	111
Engine Protection Plans (Extended Service Contract).....	119	Fuel Tank Water and Sediment - Drain.....	112
Engine Starting.....	16, 56	Drain the Water and the Sediment.....	112
Engine Stopping.....	17, 68	Fuel Storage Tanks.....	112
		Fuel Tank.....	112
<b>F</b>		<b>G</b>	
Fan Clearance - Check.....	106	Gauges and Indicators.....	36
Fault Logging.....	52	Aftertreatment Lamps.....	37
Features and Controls.....	36	Indicator Lamps.....	37
Fire Prevention and Explosion Prevention.....	12	General Hazard Information.....	7
Fire Extinguisher.....	14	Containing Fluid Spillage.....	9
Lines, Tubes, and Hoses.....	14	Dispose of Waste Properly.....	11
Regeneration.....	14	Fluid Penetration.....	9
Fluid Recommendations.....	70, 72	Inhalation.....	10
ELC Cooling System Maintenance.....	75	Pressurized Air and Water.....	9
Engine Oil.....	71	Static Electricity Hazard when Fueling with Ultra-low Sulfur Diesel Fuel.....	9
General Coolant Information.....	72	General Information.....	20
General Lubricant Information.....	70		
Fluid Recommendations (Fuel Specification).....	77	<b>H</b>	
Contamination Control Recommendations for Fuels.....	84	High Pressure Fuel Lines.....	15
Diesel Fuel Characteristics.....	80	Hoses and Clamps - Inspect/Replace.....	112
Diesel Fuel Requirements.....	77	Replace the Hoses and the Clamps.....	113
General Information.....	77	<b>I</b>	
Foreword.....	4	Important Safety Information.....	2
California Proposition 65 Warning.....	4	<b>L</b>	
Literature Information.....	4	Lifting and Storage.....	34
Maintenance.....	4	<b>M</b>	
Maintenance Intervals.....	5	Maintenance Interval Schedule.....	88
Operation.....	4	Commissioning.....	89
Overhaul.....	5	Daily.....	88
Safety.....	4	Every 1000 Service Hours.....	88
Fuel and the Effect from Cold Weather.....	66	Every 12 000 Service Hours or 6 Years.....	89
Fuel Conservation Practices.....	63	Every 1500 Service Hours.....	88
Fuel Related Components in Cold Weather ...	66	Every 2000 Service Hours.....	88
Fuel Filters.....	66	Every 3000 Service Hours.....	88
Fuel Heaters.....	67		
Fuel Tanks.....	66		
Fuel System - Prime.....	107		

Every 3000 Service Hours or 2 Years .....	89	Condition for Storage.....	34
Every 4000 Service Hours.....	89	<b>R</b>	
Every 50 Service Hours or Monthly .....	88	Radiator - Clean .....	114
Every 50 Service Hours or Weekly.....	88	Radiator Pressure Cap - Clean/Replace.....	115
Every 500 Service Hours.....	88	Reference Information.....	33
Every 500 Service Hours or 1 Year .....	88	Record for Reference .....	33
Every 6000 Service Hours or 3 Years .....	89	Reference Information Section .....	119
Every Week .....	88	Reference Materials .....	119
When Required.....	88	Refill Capacities.....	70
Maintenance Recommendations .....	85	Cooling System.....	70
Maintenance Section.....	70	Lubrication System .....	70
Model View Illustrations .....	20	<b>S</b>	
Engine and Aftertreatment.....	20	Safety Messages.....	6
Engine View with Through Flow Diesel		Universal Warning .....	6
Particulate Filter .....	26	Safety Section .....	6
Engine View with Wall Flow Diesel Particulate		Self-Diagnostics .....	52
Filter .....	24	Sensors and Electrical Components.....	40
Monitoring System.....	37	Full Engine Views .....	40
Programmable Options and Systems		Sensors and Electrical Components	
Operation .....	37	(Aftertreatment) .....	49
Monitoring System (Table for the Indicator		Differential Pressure sensor .....	51
lamps).....	38	Through Flow Aftertreatment.....	50
Mounting and Dismounting .....	14	Wall Flow Aftertreatment .....	50
<b>O</b>		Severe Service Application .....	87
Operation Section.....	34	Environmental Factors.....	87
Overspeed.....	39	Incorrect Maintenance Procedures .....	87
Oxygen Sensor - Replace .....	114	Incorrect Operating Procedures .....	87
<b>P</b>		Starting Motor - Inspect.....	115
Plate Locations and Film Locations		Starting the Engine.....	57
(Aftertreatment) .....	31–32	Starting the Engine .....	57
Through-Flow Diesel Particulate Filter		Starting with Jump Start Cables (Do Not	
(DPF) .....	32	Use This Procedure in Hazardous	
Wall Flow Diesel Particulate Filter (DPF) ....	31	Locations that have Explosive	
Plate Locations and Film Locations (Engine)..	29	Atmospheres) .....	57
Serial Number location .....	29	Stopping the Engine .....	68
Product Description.....	26	System Pressure Release.....	85
Aftermarket Products and Perkins		Coolant System .....	85
Engines .....	28	Engine Oil .....	85
Electronic Engine Features .....	27	Fuel System.....	85
Engine Cooling and Lubrication .....	28	<b>T</b>	
Engine Diagnostics.....	27	Table of Contents .....	3
Engine Service Life.....	28	Turbocharger - Inspect.....	115
Engine Specifications .....	26	<b>W</b>	
Product Identification Information .....	29	Walk-Around Inspection .....	116
Product Information Section.....	20		
Product Lifting .....	34		
Product Storage (Engine and			
Aftertreatment) .....	34		

High Pressure Fuel Lines .....	117
Inspect the Engine for Leaks and for Loose Connections .....	116
Warranty Information.....	118
Warranty Section.....	118
Water Pump - Inspect.....	117
Welding on Engines with Electronic Controls .....	85



# Product and Dealer Information

Note: For product identification plate locations, see the section "Product Identification Information" in the Operation and Maintenance Manual.

Delivery Date: \_\_\_\_\_

## Product Information

Model: \_\_\_\_\_

Product Identification Number: \_\_\_\_\_

Engine Serial Number: \_\_\_\_\_

Transmission Serial Number: \_\_\_\_\_

Generator Serial Number: \_\_\_\_\_

Attachment Serial Numbers: \_\_\_\_\_

Attachment Information: \_\_\_\_\_

Customer Equipment Number: \_\_\_\_\_

Dealer Equipment Number: \_\_\_\_\_

## Dealer Information

Name: \_\_\_\_\_ Branch: \_\_\_\_\_

Address: \_\_\_\_\_

\_\_\_\_\_

\_\_\_\_\_

Dealer Contact

Phone Number

Hours

Sales: \_\_\_\_\_

Parts: \_\_\_\_\_

Service: \_\_\_\_\_

