



THE HEART OF EVERY GREAT MACHINE

SEBU8311-11 (en-us)  
May 2023

# Operation and Maintenance Manual

---

**400A and 400D Industrial Engines**

---

## Important Safety Information

Most accidents that involve product operation, maintenance and repair are caused by failure to observe basic safety rules or precautions. An accident can often be avoided by recognizing potentially hazardous situations before an accident occurs. A person must be alert to potential hazards. This person should also have the necessary training, skills and tools to perform these functions correctly.

**Incorrect operation, lubrication, maintenance or repair of this product can be dangerous and could result in injury or death.**

**Do not operate or perform any lubrication, maintenance or repair on this product, until you have read and understood the operation, lubrication, maintenance and repair information.**

Safety precautions and warnings are provided in this manual and on the product. If these hazard warnings are not heeded, bodily injury or death could occur to you or to other persons.

The hazards are identified by the "Safety Alert Symbol" and followed by a "Signal Word" such as "DANGER", "WARNING" or "CAUTION". The Safety Alert "WARNING" label is shown below.



The meaning of this safety alert symbol is as follows:

**Attention! Become Alert! Your Safety is Involved.**

The message that appears under the warning explains the hazard and can be either written or pictorially presented.

Operations that may cause product damage are identified by "NOTICE" labels on the product and in this publication.

**Perkins cannot anticipate every possible circumstance that might involve a potential hazard. The warnings in this publication and on the product are, therefore, not all inclusive. You must not use this product in any manner different from that considered by this manual without first satisfying yourself that you have considered all safety rules and precautions applicable to the operation of the product in the location of use, including site-specific rules and precautions applicable to the worksite. If a tool, procedure, work method or operating technique that is not specifically recommended by Perkins is used, you must satisfy yourself that it is safe for you and for others. You should also ensure that you are authorized to perform this work, and that the product will not be damaged or become unsafe by the operation, lubrication, maintenance or repair procedures that you intend to use.**

The information, specifications, and illustrations in this publication are on the basis of information that was available at the time that the publication was written. The specifications, torques, pressures, measurements, adjustments, illustrations, and other items can change at any time. These changes can affect the service that is given to the product. Obtain the complete and most current information before you start any job. Perkins dealers or Perkins distributors have the most current information available.



**When replacement parts are required for this product Perkins recommends using Perkins replacement parts.**

**Failure to heed this warning can lead to premature failures, product damage, personal injury or death.**

**In the United States, the maintenance, replacement, or repair of the emission control devices and systems may be performed by any repair establishment or individual of the owner's choosing.**

---

## Table of Contents

Foreword .....	4
----------------	---

### Safety Section

Safety Messages .....	6
-----------------------	---

General Hazard Information .....	8
----------------------------------	---

Burn Prevention .....	11
-----------------------	----

Fire Prevention and Explosion Prevention .....	11
--	----

Crushing Prevention and Cutting Prevention ..	13
---	----

Before Starting Engine .....	13
------------------------------	----

Engine Starting .....	14
-----------------------	----

Engine Stopping .....	14
-----------------------	----

Electrical System .....	14
-------------------------	----

### Product Information Section

Model Views .....	16
-------------------	----

Product Identification Information .....	26
--	----

### Operation Section

Lifting and Storage .....	28
---------------------------	----

Gauges and Indicators .....	31
-----------------------------	----

Features and Controls .....	32
-----------------------------	----

Engine Starting .....	33
-----------------------	----

Engine Operation .....	36
------------------------	----

Engine Stopping .....	37
-----------------------	----

Cold Weather Operation .....	38
------------------------------	----

### Maintenance Section

Refill Capacities .....	42
-------------------------	----

Maintenance Recommendations .....	59
-----------------------------------	----

Maintenance Interval Schedule .....	61
-------------------------------------	----

### Warranty Section

Warranty Information .....	95
----------------------------	----

### Index Section

Index .....	96
-------------	----

## Foreword

### California Proposition 65 Warning

**Diesel engine exhaust and some of its constituents are known to the State of California to cause cancer, birth defects, and other reproductive harm.**



**WARNING – This product can expose you to chemicals including ethylene glycol, which is known to the State of California to cause birth defects or other reproductive harm. For more information go to:**

**[www.P65Warnings.ca.gov](http://www.P65Warnings.ca.gov)**

**Do not ingest this chemical. Wash hands after handling to avoid incidental ingestion.**



**WARNING – This product can expose you to chemicals including lead and lead compounds, which are known to the State of California to cause cancer, birth defects, or other reproductive harm. For more information go to:**

**[www.P65Warnings.ca.gov](http://www.P65Warnings.ca.gov)**

**Wash hands after handling components that may contain lead.**

### Literature Information

This manual contains safety, operation instructions, lubrication, and maintenance information. This manual should be stored in or near the engine area in a literature holder or literature storage area. Read, study, and keep the manual with the literature and engine information.

English is the primary language for all Perkins publications. The English used facilitates translation and consistency.

Some photographs or illustrations in this manual show details or attachments that may be different from your engine. Guards and covers may have been removed for illustrative purposes. Continuing improvement and advancement of product design may have caused changes to your engine which are not included in this manual. Whenever a question arises regarding your engine, or this manual, please consult with your Perkins dealer or your Perkins distributor for the latest available information.

### Safety

This safety section lists basic safety precautions. In addition, this section identifies hazardous, warning situations. Read and understand the basic precautions listed in the safety section before operating or performing lubrication, maintenance, and repair on this product.

### Operation

Operating techniques outlined in this manual are basic. The operating techniques assist with developing the skills and techniques required to operate the engine more efficiently and economically. Skill and techniques develop as the operator gains knowledge of the engine and the capabilities of the engine.

The operation section is a reference for operators. Photographs and illustrations guide the operator through procedures of inspecting, starting, operating, and stopping the engine. This section also includes a discussion of electronic diagnostic information.

### Maintenance

The maintenance section is a guide to engine care. The illustrated, step-by-step instructions are grouped by service hours and/or calendar time maintenance intervals. Items in the maintenance schedule are referenced to detailed instructions that follow.

Recommended service should be performed at the appropriate intervals as indicated in the Maintenance Interval Schedule. The actual operating environment of the engine also governs the Maintenance Interval Schedule. Therefore, under severe, dusty, wet, or freezing cold operating conditions, more frequent lubrication, and maintenance than is specified in the Maintenance Interval Schedule may be necessary.

The maintenance schedule items are organized for a preventive maintenance management program. If the preventive maintenance program is followed, a periodic tune-up is not required. The implementation of a preventive maintenance management program should minimize operating costs through cost avoidances resulting from reductions in unscheduled downtime and failures.

## **Maintenance Intervals**

Perform maintenance on items at multiples of the original requirement. Each level and/or individual items in each level should be shifted ahead or back depending upon your specific maintenance practices, operation, and application. Perkins recommends that the maintenance schedules be reproduced and displayed near the engine as a convenient reminder. Perkins also recommends that a maintenance record be maintained as part of the permanent record of the engine.

Your authorized Perkins dealer or your Perkins distributor can assist you in adjusting your maintenance schedule to meet the needs of your operating environment.

## **Overhaul**

Major engine overhaul details are not covered in the Operation and Maintenance Manual except for the interval and the maintenance items in that interval. Major repairs are best left to trained personnel or an authorized Perkins distributor or dealer. Your Perkins dealer or your Perkins distributor offers various options regarding overhaul programs. If you experience a major engine failure, there are also numerous after failure overhaul options available. Consult with your Perkins dealer or your Perkins distributor for information regarding these options.

## Safety Section

i02959960

### Safety Messages

There may be several specific warning signs on your engine. The exact location and a description of the warning signs are reviewed in this section. Please become familiar with all warning signs.

Ensure that all of the warning signs are legible. Clean the warning signs or replace the warning signs if the words cannot be read or if the illustrations are not visible. Use a cloth, water, and soap to clean the warning signs. Do not use solvents, gasoline, or other harsh chemicals. Solvents, gasoline, or harsh chemicals could loosen the adhesive that secures the warning signs. The warning signs that are loosened could drop off of the engine.

Replace any warning sign that is damaged or missing. If a warning sign is attached to a part of the engine that is replaced, install a new warning sign on the replacement part. Your Perkins dealer or your distributor can provide new warning signs.

#### (A) Universal Warning

##### **WARNING**

**Do not operate or work on this equipment unless you have read and understand the instructions and warnings in the Operation and Maintenance Manuals. Failure to follow the instructions or heed the warnings could result in serious injury or death.**

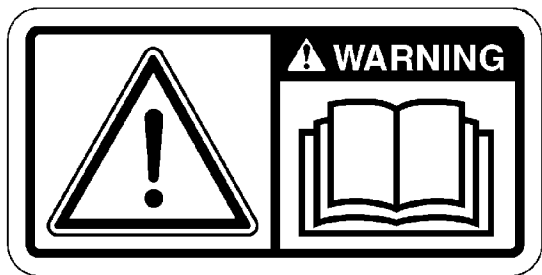

Illustration 1

g01154807

Typical example

Warning label (A) is installed in different locations. The location will change according to the physical size of the engine.

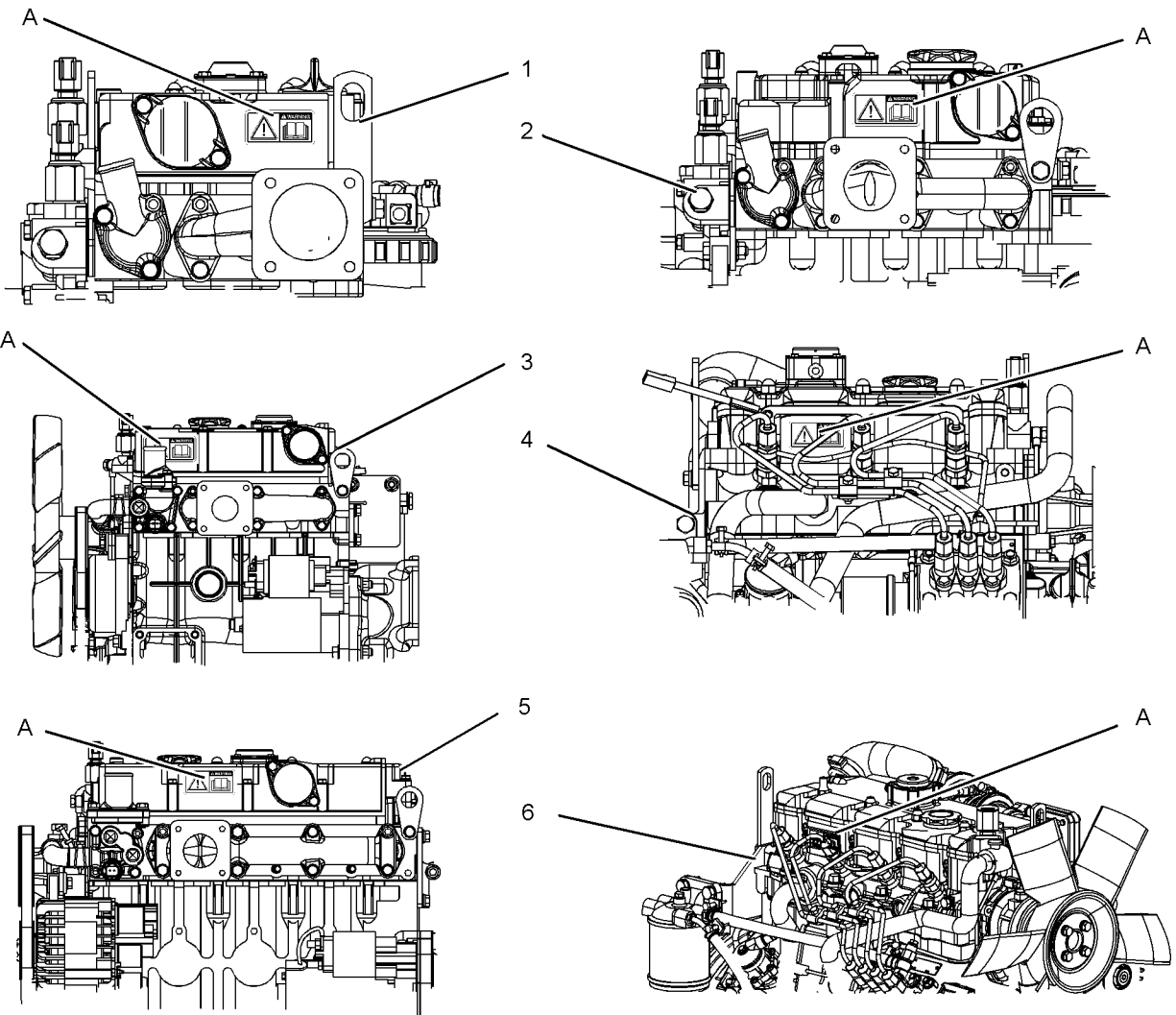

Illustration 2

g01324126

(A) Location of warning label  
(1) 402D-05  
(2) 403D-07

(3) 403D-11  
(4) 403D-15, 403D-15T and 403D-17  
(5) 404D-15

(6) 404D-22, 404D-22T and 404D-22TA

i08312758

## General Hazard Information

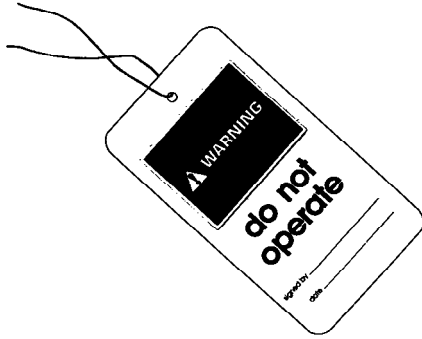

Illustration 3

g00104545

Attach a “Do Not Operate” warning tag or a similar warning tag to the start switch or to the controls before you service the equipment or before you repair the equipment.

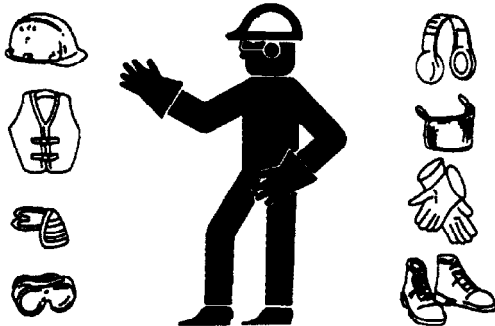

Illustration 4

g00702020

Wear a hard hat, protective glasses, and other protective equipment, as required.

Do not wear loose clothing or jewelry that can snag on controls or on other parts of the engine.

Make sure that all protective guards and all covers are secured in place on the engine.

Keep the engine free from foreign material. Remove debris, oil, tools, and other items from the deck, from walkways, and from steps.

Never put maintenance fluids into glass containers. Drain all liquids into a suitable container.

Obey all local regulations for the disposal of liquids.

Use all cleaning solutions with care.

Report all necessary repairs.

Do not allow unauthorized personnel on the equipment.

Disconnect the batteries when maintenance is performed or when the electrical system is serviced. Disconnect the battery ground leads. Tape the leads to help prevent sparks. If equipped, allow the diesel exhaust fluid to be purged before disconnecting the battery.

Perform maintenance on the engine with the equipment in the servicing position. Refer to the OEM information for the procedure for placing the equipment in the servicing position.

Do not attempt any repairs that are not understood. Use the proper tools. Replace any equipment that is damaged or repair the equipment.

For initial start-up of a new engine or for starting an engine that has been serviced, make provisions to stop the engine if an overspeed occurs. The stopping of the engine may be accomplished by shutting off the fuel supply and/or the air supply to the engine. Ensure that only the fuel supply line is shut off. Ensure that the fuel return line is open.

Start the engine from the operators station (cab). Never short across the starting motor terminals or the batteries. This action could bypass the engine neutral start system and/or the electrical system could be damaged.

Engine exhaust contains products of combustion which may be harmful to your health. Always start the engine and operate the engine in a ventilated area. If the engine is in an enclosed area, vent the engine exhaust to the outside.

Use caution when cover plates are removed. Gradually loosen, but do not remove the last two bolts or nuts that are located at opposite ends of the cover plate or the device. Before removing the last two bolts or nuts, pry the cover loose to relieve any spring pressure or other pressure.

## Pressure Air and Water

Pressurized air and/or water can cause debris and/or hot water to be blown out. This action could result in personal injury.

The direct application of pressurized air or pressurized water to the body could result in personal injury.

When pressurized air and/or water is used for cleaning, wear protective clothing, protective shoes, and eye protection. Eye protection includes goggles or a protective face shield.



The maximum air pressure for cleaning purposes must be below 205 kPa (30 psi). The maximum water pressure for cleaning purposes must be below 275 kPa (40 psi).

## Fluid Penetration

Pressure can be trapped in the hydraulic circuit long after the engine has been stopped. The pressure can cause hydraulic fluid or items such as pipe plugs to escape rapidly if the pressure is not relieved correctly.

Do not remove any hydraulic components or parts until pressure has been relieved or personal injury may occur. Do not disassemble any hydraulic components or parts until pressure has been relieved or personal injury may occur. Refer to the OEM information for any procedures that are required to relieve the hydraulic pressure.

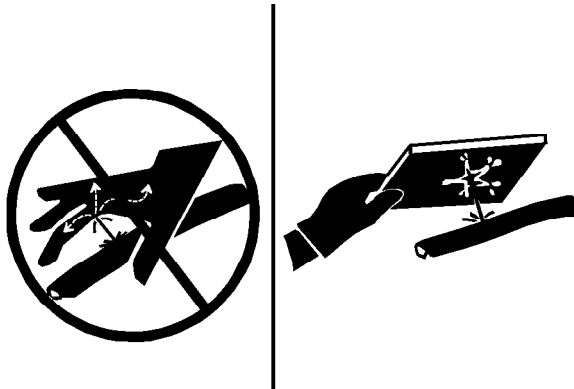

Illustration 5

g00687600

Always use a board or cardboard when you check for a leak. Leaking fluid that is under pressure can penetrate body tissue. Fluid penetration can cause serious injury and possible death. A pin hole leak can cause severe injury. If fluid is injected into your skin, you must get treatment immediately. Seek treatment from a doctor that is familiar with this type of injury.

## Containing Fluid Spillage

Care must be taken to ensure that fluids are contained during performance of inspection, maintenance, testing, adjusting, and repair of the engine. Make provision to collect the fluid with a suitable container before any compartment is opened or before any component is disassembled.

- Only use the tools that are suitable for collecting fluids and equipment that is suitable for collecting fluids.
- Only use the tools that are suitable for containing fluids and equipment that is suitable for containing fluids.

Obey all local regulations for the disposal of liquids.

## Static Electricity Hazard when Fueling with Ultra-low Sulfur Diesel Fuel

The removal of sulfur and other compounds in ultra-low sulfur diesel fuel (ULSD fuel) decreases the conductivity of ULSD and increases the ability of ULSD to store static charge. Refineries may have treated the fuel with a static dissipating additive. Many factors can reduce the effectiveness of the additive over time. Static charges can build up in ULSD fuel while the fuel is flowing through fuel delivery systems. Static electricity discharge when combustible vapors are present could result in a fire or explosion. Ensure that the entire system used to refuel your machine (fuel supply tank, transfer pump, transfer hose, nozzle, and others) is properly grounded and bonded. Consult with your fuel or fuel system supplier to ensure that the delivery system complies with fueling standards for proper grounding and bonding.

### WARNING

Avoid static electricity risk when fueling. Ultra-low sulfur diesel fuel (ULSD fuel) poses a greater static ignition hazard than earlier diesel formulations with a higher sulfur contents. Avoid death or serious injury from fire or explosion. Consult with your fuel or fuel system supplier to ensure the delivery system is in compliance with fueling standards for proper grounding and bonding practices.

## Inhalation

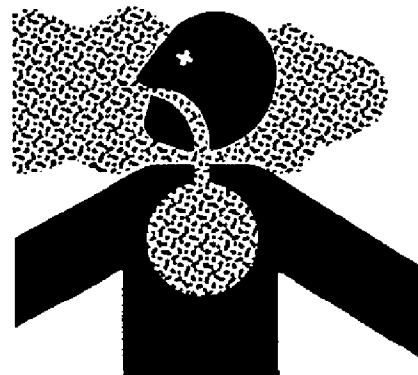

Illustration 6

g00702022

## Exhaust

Use caution. Exhaust fumes can be hazardous to health. If you operate the equipment in an enclosed area, adequate ventilation is necessary.

## Hexavalent Chromium

Perkins equipment and replacement parts comply with applicable regulations and requirements where originally sold. Perkins recommends the use of only genuine Perkins replacement parts.

Hexavalent chromium has occasionally been detected on exhaust and heat shield systems on Perkins engines. Although laboratory testing is the only accurate way to know if hexavalent chromium is, in fact, present, the presence of a yellow deposit in areas of high heat (for example, exhaust system components or exhaust insulation) may be an indication of the presence of hexavalent chromium.

Use caution if you suspect the presence of hexavalent chromium. Avoid skin contact when handling items that you suspect may contain hexavalent chromium, and avoid inhalation of any dust in the suspect area. Inhalation of, or skin contact with, hexavalent chromium dust may be hazardous to your health.

If such yellow deposits are found on the engine, engine component parts, or associated equipment or packages, Perkins recommends following local health and safety regulations and guidelines, utilizing good hygiene, and adhering to safe work practices when handling the equipment or parts. Perkins also recommends the following:

- Wear appropriate Personal Protective Equipment (PPE)
- Wash your hands and face with soap and water prior to eating, drinking, or smoking, and also during rest room breaks, to prevent ingestion of any yellow powder
- Never use compressed air for cleaning areas suspected of containing hexavalent chromium
- Avoid brushing, grinding, or cutting materials suspected of containing hexavalent chromium
- Obey environmental regulations for the disposal of all materials that may contain or have come into contact with hexavalent chromium
- Stay away from areas that might have hexavalent chromium particles in the air.

## Asbestos Information

Perkins equipment and replacement parts that are shipped from Perkins engine company limited are asbestos free. Perkins recommends the use of only genuine Perkins replacement parts. Use the following guidelines when you handle any replacement parts that contain asbestos or when you handle asbestos debris.

Use caution. Avoid inhaling dust that might be generated when you handle components that contain asbestos fibers. Inhaling this dust can be hazardous to your health. The components that may contain asbestos fibers are brake pads, brake bands, lining material, clutch plates, and some gaskets. The asbestos that is used in these components is usually bound in a resin or sealed in some way. Normal handling is not hazardous unless airborne dust that contains asbestos is generated.

If dust that may contain asbestos is present, there are several guidelines that should be followed:

- Never use compressed air for cleaning.
- Avoid brushing materials that contain asbestos.
- Avoid grinding materials that contain asbestos.
- Use a wet method to clean up asbestos materials.
- A vacuum cleaner that is equipped with a high efficiency particulate air filter (HEPA) can also be used.
- Use exhaust ventilation on permanent machining jobs.
- Wear an approved respirator if there is no other way to control the dust.
- Comply with applicable rules and regulations for the work place. In the United States, use Occupational Safety and Health Administration (OSHA) requirements. These OSHA requirements can be found in "29 CFR 1910.1001".
- Obey environmental regulations for the disposal of asbestos.
- Stay away from areas that might have asbestos particles in the air.

## Dispose of Waste Properly

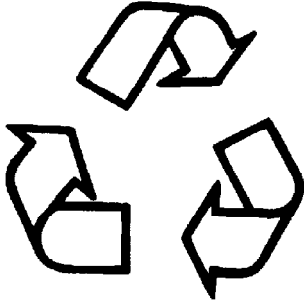

Illustration 7

g00706404

Improperly disposing of waste can threaten the environment. Potentially harmful fluids should be disposed of in accordance with local regulations.

Always use leakproof containers when you drain fluids. Do not pour waste onto the ground, down a drain, or into any source of water.

i07188265

## Burn Prevention

Do not touch any part of an operating engine. Operating engines exhaust gases could burn, do not come in contact with hot gases. Allow the engine to cool before any maintenance is performed on the engine. Relieve all pressure in the air system, in the hydraulic system, in the lubrication system, in the fuel system, or in the cooling system before any lines, fittings, or related items are disconnected.

### Coolant

When the engine is at operating temperature, the engine coolant is hot. The coolant is also under pressure. The radiator and all lines to the heaters or to the engine contain hot coolant.

Any contact with hot coolant or with steam can cause severe burns. Allow cooling system components to cool before the cooling system is drained.

Check that the coolant level after the engine has stopped and the engine has been allowed to cool.

Ensure that the filler cap is cool before removing the filler cap. The filler cap must be cool enough to touch with a bare hand. Remove the filler cap slowly to relieve pressure.

Cooling system conditioner contains alkali. Alkali can cause personal injury. Do not allow alkali to contact the skin, the eyes, or the mouth.

### Oils

Skin may be irritated following repeated or prolonged exposure to mineral and synthetic base oils. Refer to your suppliers Material Safety Data Sheets for detailed information. Hot oil and lubricating components can cause personal injury. Do not allow hot oil to contact the skin. Appropriate personal protective equipment should be used.

### Diesel Fuel

Diesel may be irritating to the eyes, respiratory system, and skin. Prolonged exposure to diesel may cause various skin conditions. Appropriate personal protective equipment should be used. Refer to supplier Material safety Data sheets for detailed information.

### Batteries

Electrolyte is an acid. Electrolyte can cause personal injury. Do not allow electrolyte to contact the skin or the eyes. Always wear protective glasses for servicing batteries. Wash hands after touching the batteries and connectors. Use of gloves is recommended.

i07188311

## Fire Prevention and Explosion Prevention



Illustration 8

g00704000

All fuels, most lubricants, and some coolant mixtures are flammable.

Safety Section  
Fire Prevention and Explosion Prevention

---

Flammable fluids that are leaking or spilled onto hot surfaces or onto electrical components can cause a fire. Fire may cause personal injury and property damage.

A flash fire may result if the covers for the engine crankcase are removed within 15 minutes after an emergency shutdown.

Determine whether the engine will be operated in an environment that allows combustible gases to be drawn into the air inlet system. These gases could cause the engine to overspeed. Personal injury, property damage, or engine damage could result.

If the application involves the presence of combustible gases, consult your Perkins dealer and/or your Perkins distributor for additional information about suitable protection devices.

Remove all flammable combustible materials or conductive materials such as fuel, oil, and debris from the engine. Do not allow any flammable combustible materials or conductive materials to accumulate on the engine.

Store fuels and lubricants in correctly marked containers away from unauthorized persons. Store oily rags and any flammable materials in protective containers. Do not smoke in areas that are used for storing flammable materials.

Do not expose the engine to any flame.

Exhaust shields (if equipped) protect hot exhaust components from oil or fuel spray in case of a line, a tube, or a seal failure. Exhaust shields must be installed correctly.

Do not weld on lines or tanks that contain flammable fluids. Do not flame-cut lines or tanks that contain flammable fluid. Clean any such lines or tanks thoroughly with a nonflammable solvent prior to welding or flame cutting.

Wiring must be kept in good condition. Ensure that all electrical wires are correctly installed and securely attached. Check all electrical wires daily. Repair any wires that are loose or frayed before you operate the engine. Clean all electrical connections and tighten all electrical connections.

Eliminate all wiring that is unattached or unnecessary. Do not use any wires or cables that are smaller than the recommended gauge. Do not bypass any fuses and/or circuit breakers.

Arcing or sparking could cause a fire. Secure connections, recommended wiring, and correctly maintained battery cables will help to prevent arcing or sparking.

Inspect all lines and hoses for wear or for deterioration. The hoses must be correctly routed. The lines and hoses must have adequate support and secure clamps. Tighten all connections to the recommended torque. Leaks can cause fires.

Oil filters and fuel filters must be correctly installed. The filter housings must be tightened to the correct torque.

---



Illustration 9

g00704059

Use caution when you are refueling an engine. Do not smoke while you are refueling an engine. Do not refuel an engine near open flames or sparks. Always stop the engine before refueling.

---



Illustration 10

g00704135

Gases from a battery can explode. Keep any open flames or sparks away from the top of a battery. Do not smoke in battery charging areas.

Never check the battery charge by placing a metal object across the terminal posts. Use a voltmeter or a hydrometer.

Incorrect jumper cable connections can cause an explosion that can result in injury. Refer to the Operation Section of this manual for specific instructions.

Do not charge a frozen battery. This action may cause an explosion.

The batteries must be kept clean. The covers (if equipped) must be kept on the cells. Use the recommended cables, connections, and battery box covers when the engine is operated.

## Fire Extinguisher

Make sure that a fire extinguisher is available. Be familiar with the operation of the fire extinguisher. Inspect the fire extinguisher and service the fire extinguisher regularly. Obey the recommendations on the instruction plate.

## Ether

Ether is flammable and poisonous.

Do not smoke while you are replacing an ether cylinder or while you are using an ether spray.

Do not store ether cylinders in living areas or in the engine compartment. Do not store ether cylinders in direct sunlight or in temperatures above 49° C (120° F). Keep ether cylinders away from open flames or sparks.

## Lines, Tubes, and Hoses

Do not bend high-pressure lines. Do not strike high-pressure lines. Do not install any lines that are bent or damaged. Do not clip any other items to the high-pressure lines.

Repair any lines that are loose or damaged. Leaks can cause fires. Consult your Perkins dealer or your Perkins distributor for repair or for replacement parts.

Check lines, tubes, and hoses carefully. Do not use your bare hand to check for leaks. Use a board or cardboard to check for leaks. Tighten all connections to the recommended torque.

Replace the parts if any of the following conditions are present:

- End fittings are damaged or leaking.
- Outer coverings are chafed or cut.
- Wires are exposed.
- Outer coverings are ballooning.
- Flexible parts of the hoses are kinked.
- Outer covers have embedded armoring.

- End fittings are displaced.

Make sure that all clamps, guards, and heat shields are installed correctly. During engine operation, correct installation will help to prevent vibration, rubbing against other parts, and excessive heat.

i02143194

## Crushing Prevention and Cutting Prevention

Support the component correctly when work beneath the component is performed.

Unless other maintenance instructions are provided, never attempt adjustments while the engine is running.

Stay clear of all rotating parts and of all moving parts. Leave the guards in place until maintenance is performed. After the maintenance is performed, reinstall the guards.

Keep objects away from moving fan blades. The fan blades will throw objects or cut objects.

When objects are struck, wear protective glasses in order to avoid injury to the eyes.

Chips or other debris may fly off objects when objects are struck. Before objects are struck, ensure that no one will be injured by flying debris.

i05874054

## Before Starting Engine

### NOTICE

For initial start-up of a new or rebuilt engine, and for start-up of an engine that has been serviced, make provision to shut the engine off should an overspeed occur. This may be accomplished by shutting off the air and/or fuel supply to the engine.

### WARNING

**Engine exhaust contains products of combustion which may be harmful to your health. Always start and operate the engine in a well ventilated area and, if in an enclosed area, vent the exhaust to the outside.**

Inspect the engine for potential hazards.

Do not start the engine or move any of the controls if there is a "DO NOT OPERATE" warning tag or similar warning tag attached to the start switch or to the controls.

## Safety Section Engine Starting

Before starting the engine, ensure that no one is on, underneath, or close to the engine. Ensure that the area is free of personnel.

If equipped, ensure that the lighting system for the engine is suitable for the conditions. Ensure that all lights work properly, if equipped.

All protective guards and all protective covers must be installed if the engine must be started in order to perform service procedures. To help prevent an accident that is caused by parts in rotation, work around the parts carefully.

Do not bypass the automatic shutoff circuits. Do not disable the automatic shutoff circuits. The circuits are provided in order to help prevent personal injury. The circuits are also provided in order to help prevent engine damage.

See the Service Manual for repairs and for adjustments.

i02157354

## Engine Starting

### WARNING

**Do not use aerosol types of starting aids such as ether. Such use could result in an explosion and personal injury.**

If a warning tag is attached to the engine start switch or to the controls, DO NOT start the engine or move the controls. Consult with the person that attached the warning tag before the engine is started.

All protective guards and all protective covers must be installed if the engine must be started in order to perform service procedures. To help prevent an accident that is caused by parts in rotation, work around the parts carefully.

Start the engine from the operator's compartment or from the engine start switch.

Always start the engine according to the procedure that is described in the Operation and Maintenance Manual, "Engine Starting" topic in the Operation Section. Knowing the correct procedure will help to prevent major damage to the engine components. Knowing the procedure will also help to prevent personal injury.

To ensure that the jacket water heater (if equipped) and/or the lube oil heater (if equipped) is working correctly, check the water temperature gauge and the oil temperature gauge during the heater operation.

Engine exhaust contains products of combustion which can be harmful to your health. Always start the engine and operate the engine in a well ventilated area. If the engine is started in an enclosed area, vent the engine exhaust to the outside.

**Note:** The engine is equipped with an automatic device for cold starting for normal conditions of operation. If the engine will be operated in very cold conditions, then an extra cold starting aid may be required. Normally, the engine will be equipped with the correct type of starting aid for your region of operation.

The 400 Series engines are equipped with a glow plug starting aid in each individual cylinder that heats the intake air in order to improve starting.

i02590389

## Engine Stopping

To avoid overheating of the engine and accelerated wear of the engine components, stop the engine according to this Operation and Maintenance Manual, "Engine Stopping" topic (Operation Section).

Use the Emergency Stop Button (if equipped) ONLY in an emergency situation. DO NOT use the Emergency Stop Button for normal engine stopping. After an emergency stop, DO NOT start the engine until the problem that caused the emergency stop has been corrected.

On the initial start-up of a new engine or an engine that has been serviced, make provisions to stop the engine if an overspeed condition occurs. This may be accomplished by shutting off the fuel supply and/or the air supply to the engine.

If equipped, in order to stop an electronically controlled engine, cut the power to the engine.

i02176668

## Electrical System

Never disconnect any charging unit circuit or battery circuit cable from the battery when the charging unit is operating. A spark can cause the combustible gases that are produced by some batteries to ignite.

To help prevent sparks from igniting combustible gases that are produced by some batteries, the negative "-" jump start cable should be connected last from the external power source to the negative "-" terminal of the starting motor. If the starting motor is not equipped with a negative "-" terminal, connect the jump start cable to the engine block.

Check the electrical wires daily for wires that are loose or frayed. Tighten all loose electrical wires before the engine is started. Repair all frayed electrical wires before the engine is started. See the Operation and Maintenance Manual for specific starting instructions.

## **Grounding Practices**

Correct grounding for the engine electrical system is necessary for optimum engine performance and reliability. Incorrect grounding will result in uncontrolled electrical circuit paths and in unreliable electrical circuit paths.

Uncontrolled electrical circuit paths can result in damage to main bearings, to crankshaft bearing journal surfaces, and to aluminum components.

Engines that are installed without engine-to-frame ground straps can be damaged by electrical discharge.

To ensure that the engine and the engine electrical systems function correctly, an engine-to-frame ground strap with a direct path to the battery must be used. This path may be provided by way of a direct engine ground to the frame.

All grounds should be tight and free of corrosion. The engine alternator must be grounded to the negative “-” battery terminal with a wire that is adequate to handle the full charging current of the alternator.

# Product Information Section

## Model Views

i08066301

### Model View Illustrations

The following model views show typical features of the 400 series engines. Due to individual applications, your engine may appear different from the illustrations.

**Note:** Individual components are detailed on the 404D-22T turbocharged engine only.

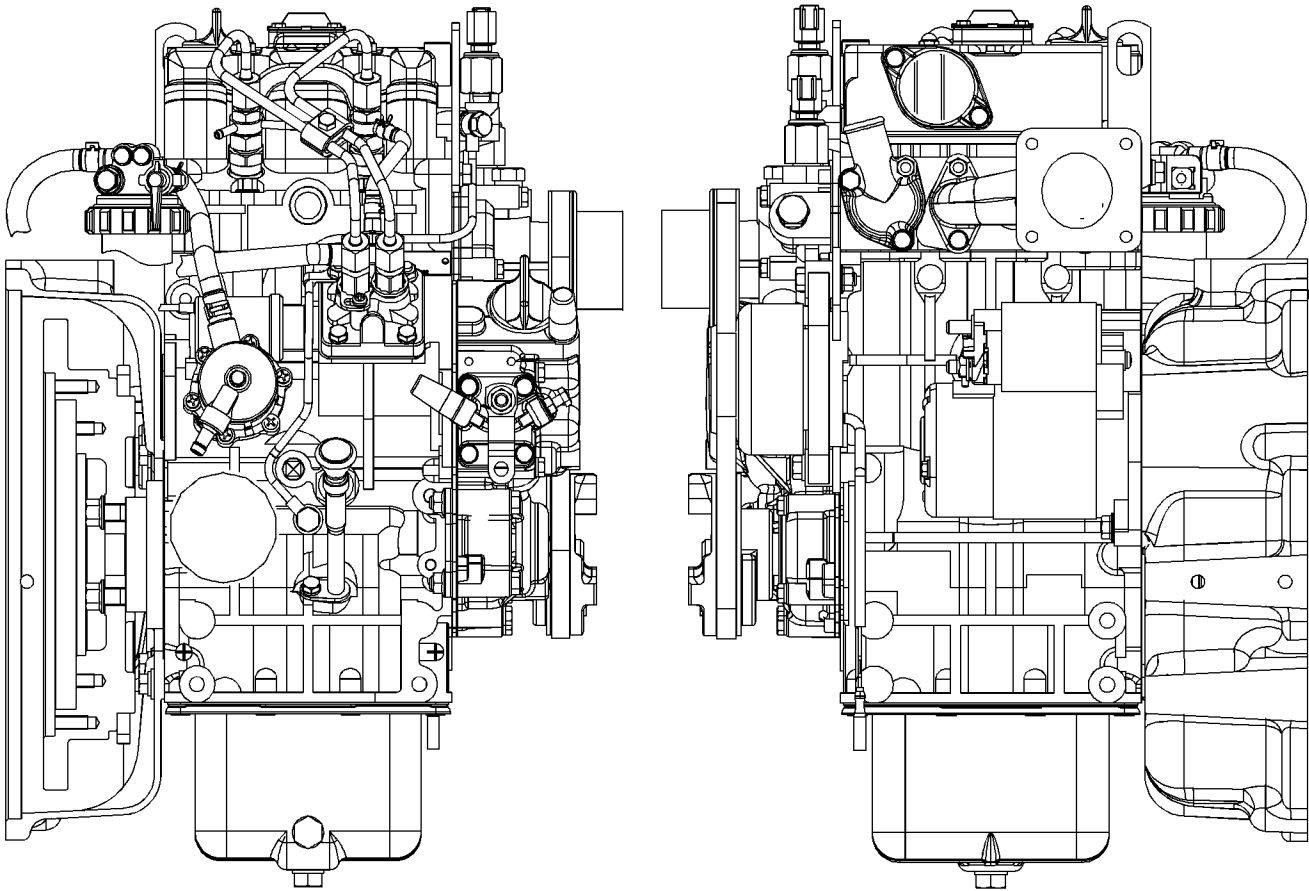

Illustration 11

Typical view of the 402D-05 engine

g01299985



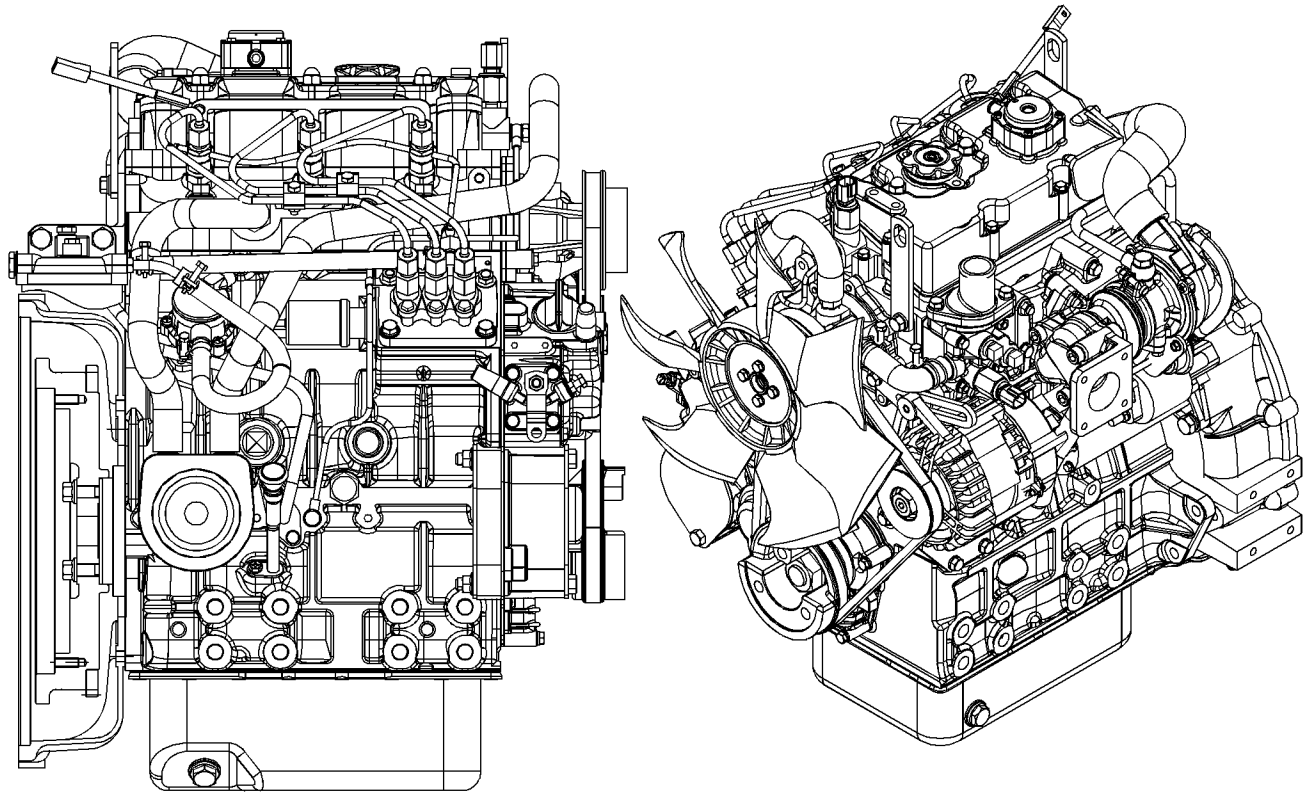

Illustration 12

Typical view of the 403D-15T engine

g01300431

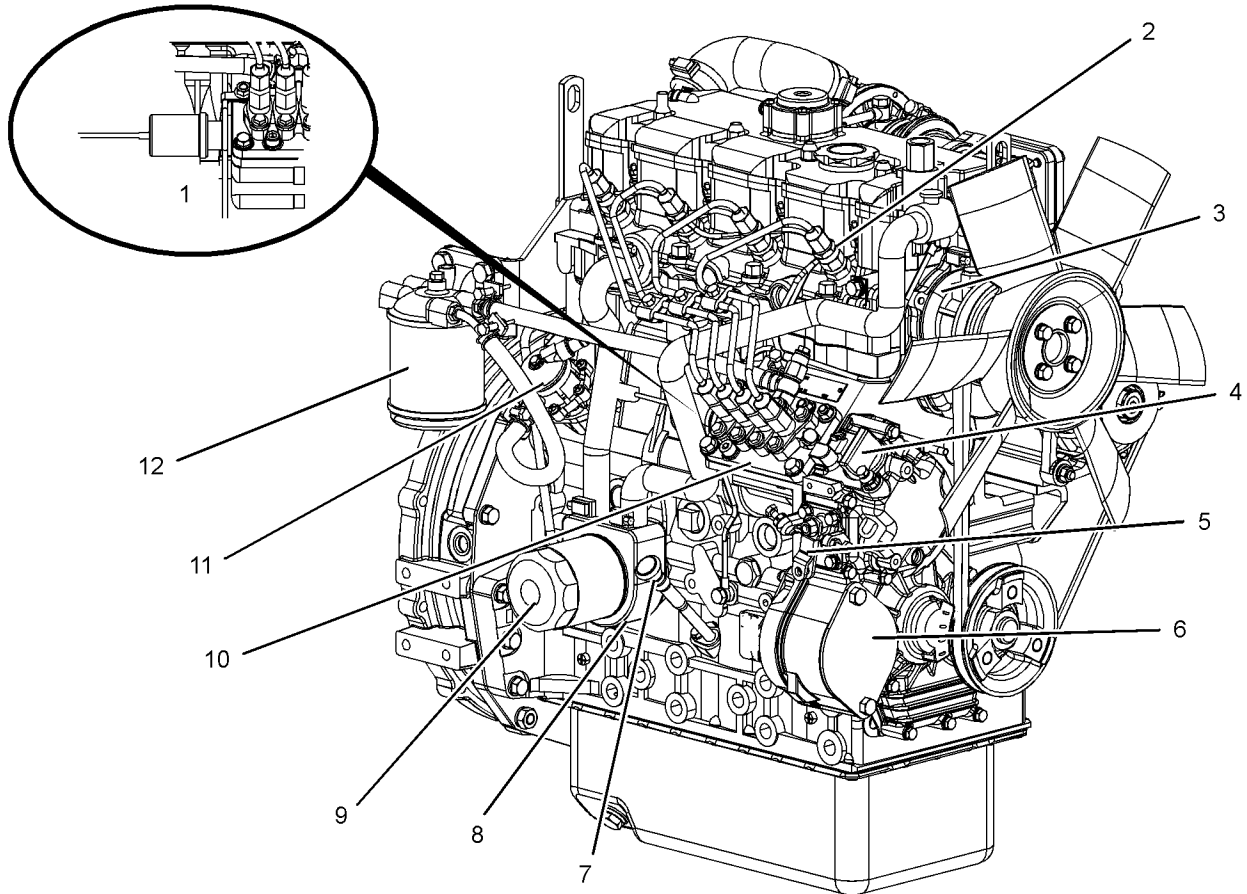

Illustration 13

g01304893

### Front and right side view of the 404D-22T Engine

- (1) Fuel shutoff solenoid
- (2) Number one fuel injector
- (3) Water pump
- (4) Lower engine oil filler cap

- (5) Throttle lever
- (6) Cover plate for the accessory drive
- (7) Engine oil level gauge
- (8) Engine oil cooler

- (9) Engine oil filter
- (10) Fuel injection pump
- (11) Transfer pump
- (12) Fuel filter

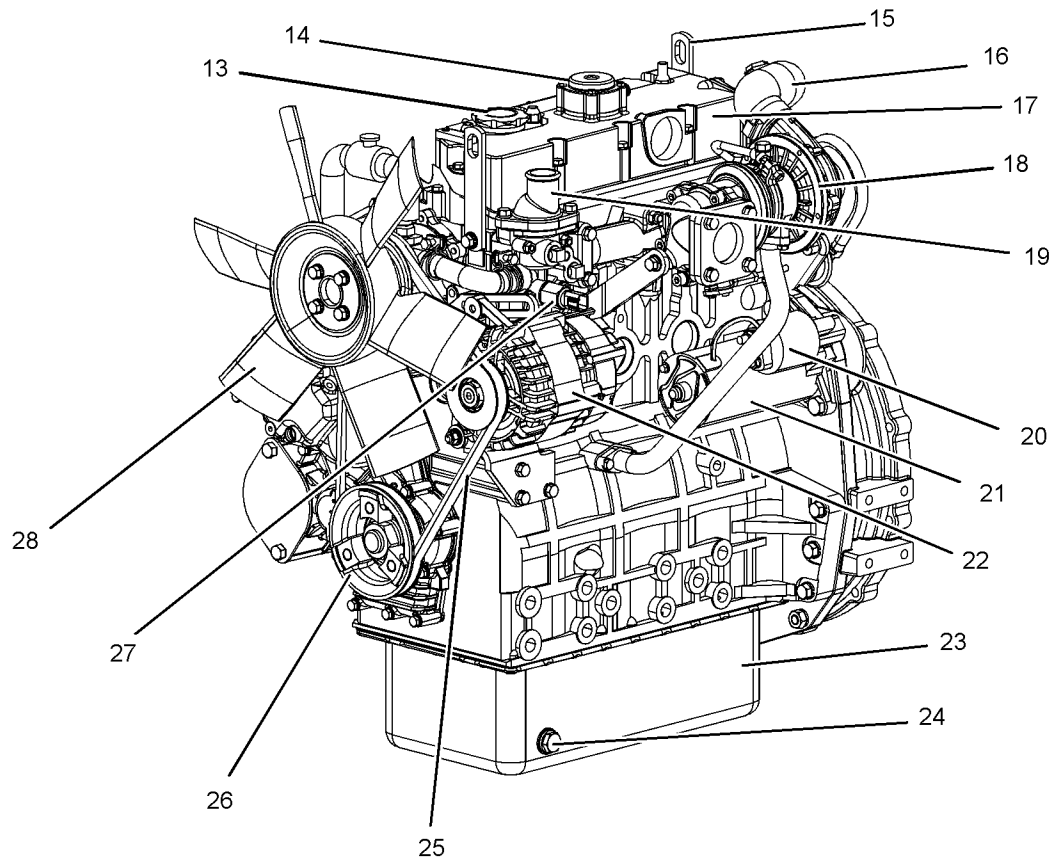

Illustration 14

g01305224

### Front and left side view of the 404D-22T Engine

- |                                |  |                                 |
|--------------------------------|--|---------------------------------|
| (13) Top engine oil filler cap | (19) Water temperature regulator housing | (25) Fan drive belt             |
| (14) Crankcase breather        | (20) Starting motor solenoid             | (26) Crankshaft pulley          |
| (15) Rear Lifting eye          | (21) Electric starting motor             | (27) Coolant temperature switch |
| (16) Air inlet elbow           | (22) Alternator                          | (28) Cooling fan                |
| (17) Valve mechanism cover     | (23) Engine oil pan                      |                                 |
| (18) Turbocharger              | (24) Engine oil drain plug               |                                 |

## Engines with Factory Installed Radiators

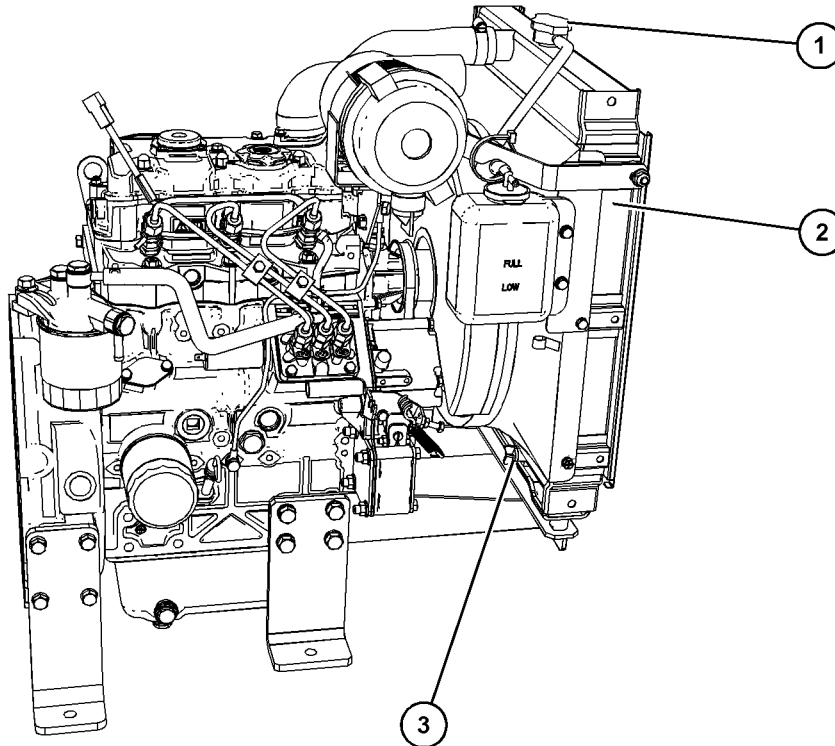

Illustration 15

Typical view of the 403D-11 IOPU engine.

g06530978

(1) Coolant filler cap

(2) Radiator

(3) Radiator drain plug

i06782463

## 402D-05 Engine

### Engine Description

The 400 series engines are built in several different variants. Naturally aspirated, turbocharged, and turbocharge aftercooled. The engine range covers two cylinder, three cylinder and four cylinder engines.

The 400 series engines can be operated as variable speed or can operate as constant speed engines.

### Engine Specifications

**Note:** The front end of the engine is opposite the flywheel end of the engine. The left and the right side of the engine is determined from the flywheel end. The No. 1 cylinder is the front cylinder.

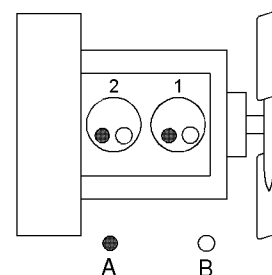

Illustration 16

g01108476

(A) Exhaust valves  
(B) Inlet valves

Table 1

402D-05 Engine Specifications	
Maximum Operating Speed (rpm)	3600 rpm
Cylinders and Arrangement	In-Line two cylinder
Bore	67 mm (2.64 inch)
Stroke	72 mm (2.83 inch)
Displacement	0.507 L (30.939 in <sup>3</sup> )
Aspiration	NA <sup>(1)</sup>
Compression Ratio	23.5:1
Firing Order	1-2
Rotation that is viewed from the flywheel	Counterclockwise
Valve Lash Setting (Inlet)	0.20 mm (0.008 inch)
Valve Lash Setting (Exhaust)	0.20 mm (0.008 inch)
Injection	Indirect

(1) Naturally Aspirated

### 403D-07 Engine

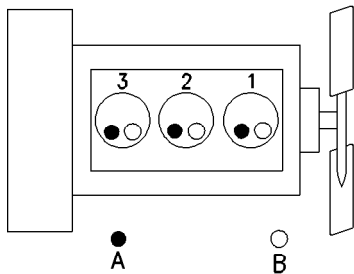

Illustration 17 g00852304

(A) Exhaust valves  
(B) Inlet valves

Table 2

403D-07 Engine Specifications	
Maximum Operating Speed (rpm)	3600 rpm
Cylinders and Arrangement	In-Line three cylinder
Bore	67 mm (2.64 inch)
Stroke	72 mm (2.83 inch)
Displacement	0.762 L (46.500 in <sup>3</sup> )

(Table 2, contd)

Aspiration	NA <sup>(1)</sup>
Compression Ratio	23.5:1
Firing Order	1-2-3
Rotation that is viewed from the flywheel	Counterclockwise
Valve Lash Setting (Inlet)	0.20 mm (0.008 inch)
Valve Lash Setting (Exhaust)	0.20 mm (0.008 inch)
Injection	Indirect

(1) Naturally Aspirated

### 403D-11 Engine

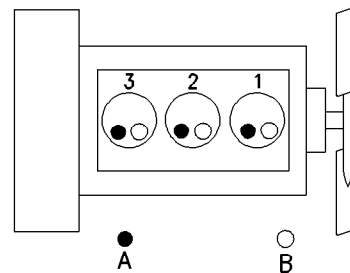

Illustration 18 g00852304

(A) Exhaust valves  
(B) Inlet valves

Table 3

403D-11 Engine Specifications	
Maximum Operating Speed (rpm)	3600 rpm
Cylinders and Arrangement	In-Line three cylinder
Bore	77 mm (3.03 inch)
Stroke	81 mm (3.19 inch)
Displacement	1.131 L (69.018 in <sup>3</sup> )
Aspiration	NA <sup>(1)</sup>
Compression Ratio	23:1
Firing Order	1-2-3
Rotation that is viewed from the flywheel	Counterclockwise

(continued)

(continued)

Product Information Section  
Engine Description

(Table 3, contd)

Valve Lash Setting (Inlet)	0.20 mm (0.008 inch)
Valve Lash Setting (Exhaust)	0.20 mm (0.008 inch)
Injection	Indirect

(1) Naturally Aspirated

### 403D-15 Engine

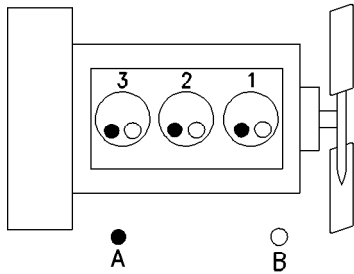

Illustration 19

g00852304

(A) Exhaust valves  
(B) Inlet valves

Table 4

403D-15 Engine Specifications	
Maximum Operating Speed (rpm)	3000 rpm
Cylinders and Arrangement	In-Line three cylinder
Bore	84 mm (3.31 inch)
Stroke	90 mm (3.54 inch)
Displacement	1.496 L (91.291 in <sup>3</sup> )
Aspiration	NA <sup>(1)</sup>
Compression Ratio	22.5:1
Firing Order	1-2-3
Rotation that is viewed from the flywheel	Counterclockwise
Valve Lash Setting (Inlet)	0.20 mm (0.008 inch)
Valve Lash Setting (Exhaust)	0.20 mm (0.008 inch)
Injection	Indirect

(1) Naturally Aspirated

### 403D-15T Engine

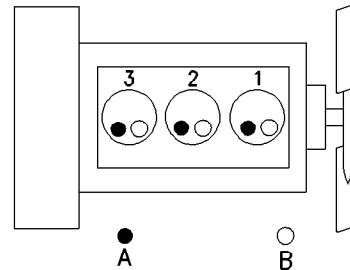

Illustration 20

g00852304

(A) Exhaust valves  
(B) Inlet valves

Table 5

403D-15T Engine Specifications	
Maximum Operating Speed (rpm)	3000 rpm
Cylinders and Arrangement	In-Line three cylinder
Bore	84 mm (3.31 inch)
Stroke	90 mm (3.54 inch)
Displacement	1.496 L (91.291 in <sup>3</sup> )
Aspiration	T <sup>(1)</sup>
Compression Ratio	22.5:1
Firing Order	1-2-3
Rotation that is viewed from the flywheel	Counterclockwise
Valve Lash Setting (Inlet)	0.20 mm (0.008 inch)
Valve Lash Setting (Exhaust)	0.20 mm (0.008 inch)
Injection	Indirect

(1) Turbocharged

**403D-17 Engine**

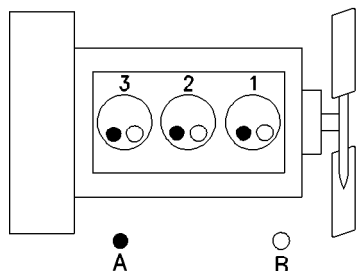

Illustration 21

g00852304

(A) Exhaust valves  
(B) Inlet valves

Table 6

403D-17 Engine Specifications	
Maximum Operating Speed (rpm)	2600 rpm
Cylinders and Arrangement	In-Line three cylinder
Bore	84 mm (3.31 inch)
Stroke	100 mm (3.94 inch)
Displacement	1.66 L (101.3 in <sup>3</sup> )
Aspiration	NA <sup>(1)</sup>
Compression Ratio	23.1:1
Firing Order	1-2-3
Rotation that is viewed from the flywheel	Counterclockwise
Valve Lash Setting (Inlet)	0.20 mm (0.008 inch)
Valve Lash Setting (Exhaust)	0.20 mm (0.008 inch)
Injection	Indirect

(1) Naturally Aspirated

**404D-15 Engine**

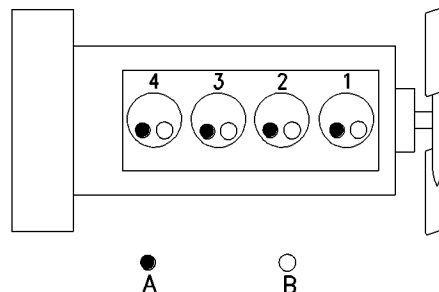

Illustration 22

g00296424

(A) Exhaust valves  
(B) Inlet valves

Table 7

404D-15 Engine Specifications	
Maximum Operating Speed (rpm)	3000 rpm
Cylinders and Arrangement	In-Line four cylinder
Bore	77 mm (3.03 inch)
Stroke	81 mm (3.19 inch)
Displacement	1.508 L (92.024 in <sup>3</sup> )
Aspiration	NA <sup>(1)</sup>
Compression Ratio	23.5:1
Firing Order	1-3-4-2
Rotation that is viewed from the flywheel	Counterclockwise
Valve Lash Setting (Inlet)	0.20 mm (0.008 inch)
Valve Lash Setting (Exhaust)	0.20 mm (0.008 inch)
Injection	Indirect

(1) Naturally Aspirated

**404D-22 Engine**

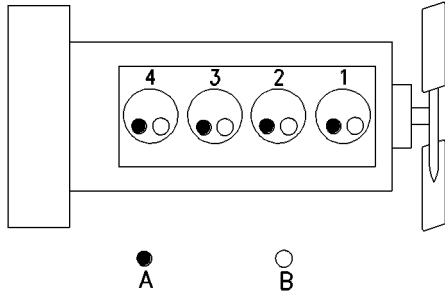

Illustration 23

g00296424

(A) Exhaust valves  
 (B) Inlet valves

Table 8

404D-22 Engine Specifications	
Maximum Operating Speed (rpm)	3000 rpm
Cylinders and Arrangement	In-Line four cylinder
Bore	84.0 mm (3.31 inch)
Stroke	100.0 mm (3.94 inch)
Displacement	2.216 L (135.229 in <sup>3</sup> )
Aspiration	NA <sup>(1)</sup>
Compression Ratio	23.3:1
Firing Order	1-3-4-2
Rotation that is viewed from the flywheel	Counterclockwise
Valve Lash Setting (Inlet)	0.20 mm (0.008 inch)
Valve Lash Setting (Exhaust)	0.20 mm (0.008 inch)
Injection	Indirect

(1) Naturally Aspirated

**404D-22T Engine**

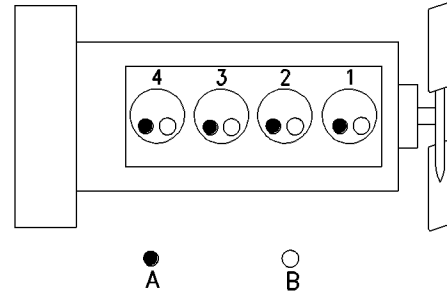

Illustration 24

g00296424

(A) Exhaust valves  
 (B) Inlet valves

Table 9

404D-22T Engine Specifications	
Maximum Operating Speed (rpm)	3000 rpm
Cylinders and Arrangement	In-Line four cylinder
Bore	84.0 mm (3.31 inch)
Stroke	100.0 mm (3.94 inch)
Displacement	2.216 L (135.229 in <sup>3</sup> )
Aspiration	T <sup>(1)</sup>
Compression Ratio	23.5:1
Firing Order	1-3-4-2
Rotation that is viewed from the flywheel	Counterclockwise
Valve Lash Setting (Inlet)	0.20 mm (0.008 inch)
Valve Lash Setting (Exhaust)	0.20 mm (0.008 inch)
Injection	Indirect

(1) Turbocharged



## 404D-22TA Engine

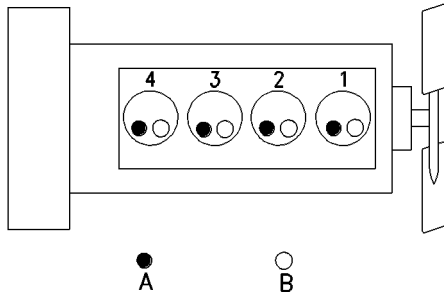

Illustration 25

g00296424

(A) Exhaust valves  
(B) Inlet valves

Table 10

404D-22TA Engine Specifications	
Maximum Operating Speed (rpm)	2800 rpm
Cylinders and Arrangement	In-Line four cylinder
Bore	84.0 mm (3.31 inch)
Stroke	100.0 mm (3.94 inch)
Displacement	2.216 L (135.229 in <sup>3</sup> )
Aspiration	TA <sup>(1)</sup>
Compression Ratio	23.5:1
Firing Order	1-3-4-2
Rotation that is viewed from the flywheel	Counterclockwise
Valve Lash Setting (Inlet)	0.20 mm (0.008 inch)
Valve Lash Setting (Exhaust)	0.20 mm (0.008 inch)
Injection	Indirect

(1) Turbocharged aftercooled

Expected engine life is generally predicted by the average power that is demanded. The average power that is demanded is based on fuel consumption of the engine over a period of time. Reduced hours of operation at full throttle and/or operating at reduced throttle settings result in a lower average power demand. Reduced hours of operation will increase the length of operating time before an engine overhaul is required.

## Aftermarket Products and Perkins Engines

Perkins does not warrant the quality or performance of non-Perkins fluids and filters.

When auxiliary devices, accessories, or consumables (filters, additives, catalysts), which are made by other manufacturers are used on Perkins products, the Perkins warranty is not affected simply because of such use.

**However, failures that result from the installation or use of other manufacturers devices, accessories, or consumables are NOT Perkins defects. Therefore, the defects are NOT covered under the Perkins warranty.**

## Service Life

Engine efficiency and maximum utilization of engine performance depend on the adherence to proper operation and maintenance recommendations. In addition, use recommended fuels, coolants, and lubricants. Use the Operation and Maintenance Manual as a guide for required engine maintenance.

# Product Identification Information

i03657510

i02164876

## Engine Identification

Perkins engines are identified by a serial number. This number is shown on a serial number plate that is mounted above the fuel injection pump on the right hand side of the engine block.

An example of an engine number is GP\*\*\*\*\*U000001T.

G \_\_\_\_\_ Engine family  
 P \_\_\_\_\_ Type of engine  
 \*\*\*\*\* \_\_\_\_\_ The list number of the engine  
 U \_\_\_\_\_ Country of manufacture  
 0 \_\_\_\_\_ The first digit is a production code.  
 00001 \_\_\_\_\_ Engine Serial Number  
 T \_\_\_\_\_ Year of Manufacture

Perkins dealers or Perkins distributors need all of these numbers in order to determine the components that were included with the engine. This permits accurate identification of replacement part numbers.

i02157258

## Serial Number Plate

The following information is stamped on the Serial Number Plate: Engine serial number, Model and Arrangement number.

## Reference Numbers

Information for the following items may be needed to order parts. Locate the information for your engine. Record the information in the appropriate space. Make a copy of this list for a record. Keep the information for future reference.

### Record for Reference

Engine Model \_\_\_\_\_  
 Engine Serial number \_\_\_\_\_  
 Engine Low Idle rpm \_\_\_\_\_  
 Engine Full Load rpm \_\_\_\_\_  
 Primary Fuel Filter \_\_\_\_\_  
 Water Separator Element \_\_\_\_\_  
 Secondary Fuel Filter Element \_\_\_\_\_  
 Lubrication Oil Filter Element \_\_\_\_\_  
 Auxiliary Oil Filter Element \_\_\_\_\_  
 Total Lubrication System Capacity \_\_\_\_\_  
 Total Cooling System Capacity \_\_\_\_\_  
 Air Cleaner Element \_\_\_\_\_  
 Fan Drive Belt \_\_\_\_\_



Illustration 26

g01094203

Typical serial number plate

The Serial Number Plate is located above the fuel injection pump on the right side of the cylinder block.

Alternator Belt \_\_\_\_\_

i07789725

# Emissions Certification Film

EMISSION CONTROL INFORMATION	
	
ENGINE FAMILY	
POWER CATEGORY	
DISPLACEMENT	Liters
EMISSION-CONTROL SYSTEM	
THIS ENGINE COMPLIES WITH U.S. EPA AND CALIFORNIA REGULATIONS FOR NONROAD DIESEL ENGINES	
LOW SULFUR FUEL OR ULTRA LOW SULFUR FUEL ONLY	
EC NRMM No. :	

Illustration 27

g01478138

Typical example

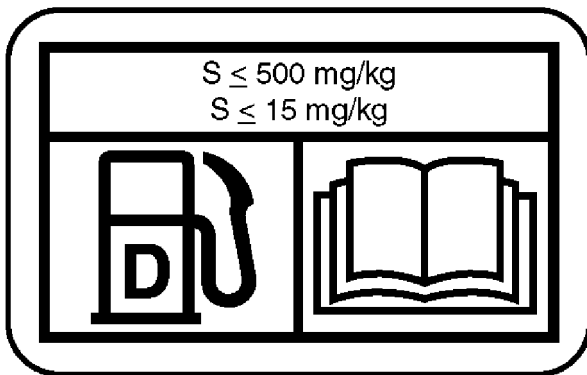

Illustration 28

g06038952

Typical example

Refer to illustration 28 . The equipment manufacturer must install the label to the equipment. This procedure is recommended by Perkins Small Engines Limited. The label must be attached to the equipment near the fuel inlet to comply with the EPA regulations. The equipment manufacturer may install another fuel label.

## Operation Section

### Lifting and Storage

i08066305

#### Engine Lifting

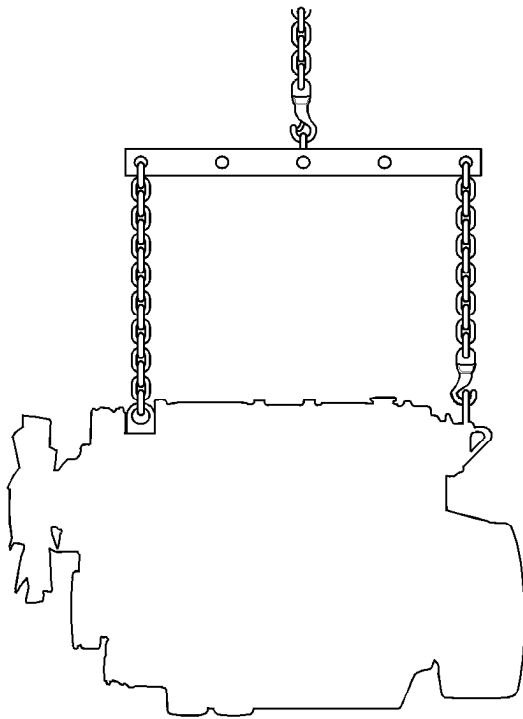

Illustration 29

g01097527

#### NOTICE

Never bend the eyebolts and the brackets. Only load the eyebolts and the brackets under tension. Remember that the capacity of an eyebolt is less as the angle between the supporting members and the object becomes less than 90 degrees.

When it is necessary to remove a component at an angle, only use a link bracket that is properly rated for the weight.

#### NOTICE

Always inspect lifting eyebolts and all other lifting equipment for damage before performing any lifting. Never bend the eyebolts and the brackets. Never perform product lifting if the components are damaged.

Use a hoist to remove heavy components. Use an adjustable lifting beam to lift the engine. All supporting members (chains and cables) should be parallel to each other. The chains and cables should be perpendicular to the top of the object that is being lifted.

Some removals require lifting the fixtures to obtain correct balance and safety.

To remove the engine ONLY, use the lifting eyes that are on the engine.

Lifting eyes are designed and installed for specific engine arrangements. Alterations to the lifting eyes and/or the engine make the lifting eyes and the lifting fixtures obsolete. If alterations are made, ensure that correct lifting devices are provided. Consult your Perkins dealer or your Perkins distributor for information regarding fixtures for correct engine lifting.

## Engine Only

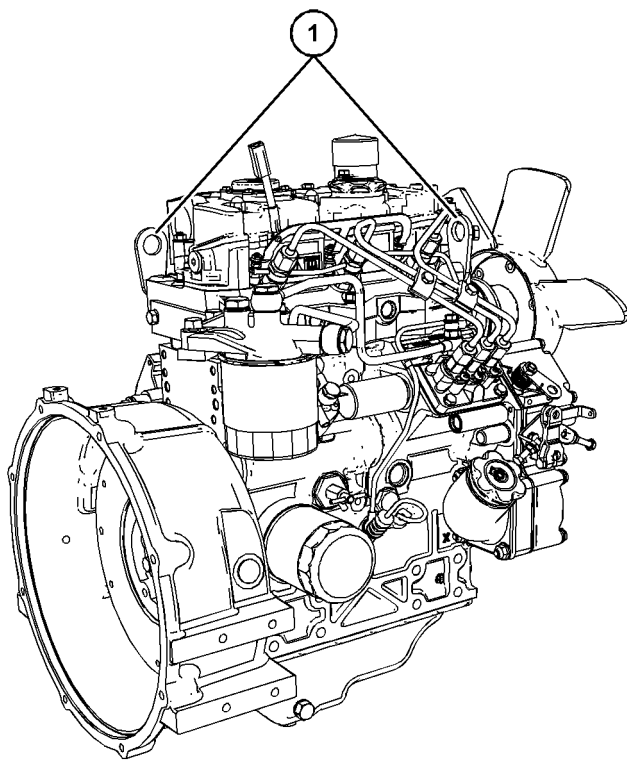

Illustration 30

g06531058

Typical example of Industrial Engine

(1) Front and rear lifting eyes

## Engines with Factory Installed Radiators

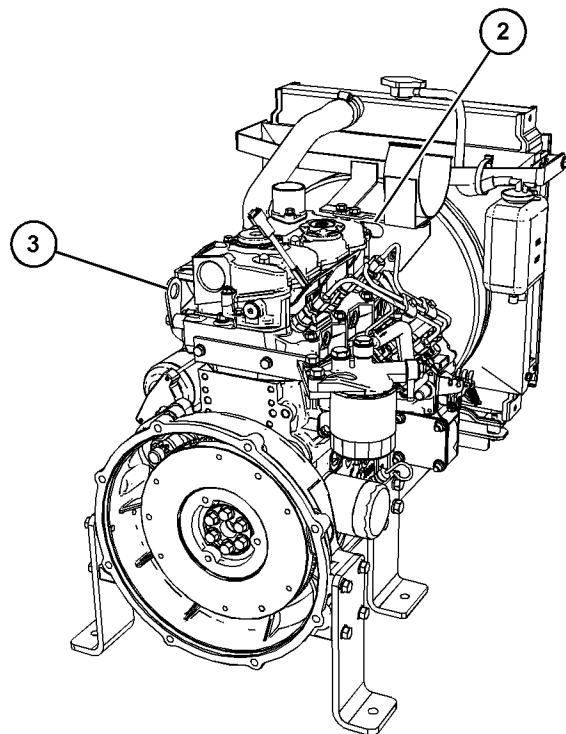

Illustration 31

g06531094

Typical example Industrial Open Power Unit (IOPU)

(2) Front lifting eye

(3) Rear lifting eye

i06791245

## Engine Storage

Perkins are not responsible for damage which may occur when an engine is in storage after a period in service.

Your Perkins dealer or your Perkins distributor can help in preparing the engine for extended storage periods.

### Condition for Storage

The engine must be stored in a water proof building. The building must be kept at a constant temperature. Engines that are filled with Perkins ELC will have coolant protection to an ambient temperature of  $-36^{\circ}\text{C}$  ( $-32.8^{\circ}\text{F}$ ). The engine must not be subjected to extreme variations in temperature and humidity.

## Storage Period

An engine can be stored for up to 6 months provided all the recommendation are adhered to.

## Storage Procedure

Keep a record of the procedure that has been completed on the engine.

**Note:** Do not store an engine that has biodiesel in the fuel system.

1. Ensure that the engine is clean and dry.
  - a. If the engine has been operated using biodiesel, the system must be drained and new filters installed. The fuel tank will require flushing.
  - b. Fill the fuel system with the correct specification of fuel. For more information on acceptable fuels refer to this Operation and Maintenance Manual, "Fluid recommendations". Operate the engine for 15 minutes to remove all biodiesel from the system.
2. Drain any water from the primary filter water separator. Ensure that the fuel tank is full.
3. The engine oil will not need to be drained to store the engine. Provided the correct specification of engine oil is used the engine can be stored for up to 6 months. For the correct specification of engine oil refer to this Operation and Maintenance Manual, "Fluid recommendations".
4. Remove the fan belt from the engine.

## Sealed Coolant System

Ensure that the cooling system is filled with the correct specification of coolant. Refer to this Operation and Maintenance Manual, "Fluid recommendations".

## Open Cooling System

Ensure that all cooling drain plugs have been opened. Allow the coolant to drain. Install the drain plugs. Place a vapor phase inhibitor into the system. The coolant system must be sealed once the vapor phase inhibitor has been introduced. The effect of the vapor phase inhibitor will be lost if the cooling system is open to the atmosphere.

For maintenance procedures ref to this Operation and Maintenance Manual.

## Monthly Checks

The crankshaft must be rotated to change the spring loading on the valve train. Rotate the crankshaft more than 180 degrees. Visibly check for damage or corrosion to the engine.

Ensure that the engine is covered completely before storage. Log the procedure in the record for the engine.

# Gauges and Indicators

i02216960

## Gauges and Indicators

Your engine may not have the same gauges or all of the gauges that are described. For more information about the gauge package, see the OEM information.

Gauges provide indications of engine performance. Ensure that the gauges are in good working order. Determine the normal operating range by observing the gauges over a period of time.

Noticeable changes in gauge readings indicate potential gauge or engine problems. Problems may also be indicated by gauge readings that change even if the readings are within specifications. Determine and correct the cause of any significant change in the readings. Consult your Perkins dealer or your Perkins distributor for assistance.

### NOTICE

If no oil pressure is indicated, STOP the engine. If maximum coolant temperature is exceeded, STOP the engine. Engine damage can result.



**Engine Oil Pressure – The oil pressure should be greatest after a cold engine is started. The typical engine oil pressure with SAE10W30 is 207 to 413 kPa (30 to 60 psi) at rated rpm.**

A lower oil pressure is normal at low idle. If the load is stable and the gauge reading changes, perform the following procedure:

1. Remove the load.
2. Reduce engine speed to low idle.
3. Check and maintain the oil level.



**Jacket Water Coolant Temperature – Typical temperature range is 71 to 96°C (160 to 205°F). The maximum allowable temperature with the pressurized cooling system at 90 kPa (13 psi) is 110°C (230°F). Higher temperatures may occur under certain conditions. The water temperature reading may vary according to load. The reading should never exceed the boiling point for the pressurized system that is being used.**

If the engine is operating above the normal range and steam becomes apparent, perform the following procedure:

1. Reduce the load and the engine rpm.
2. Inspect the cooling system for leaks.

3. Determine if the engine must be shut down immediately or if the engine can be cooled by reducing the load.



**Tachometer – This gauge indicates engine speed (rpm). When the throttle control lever is moved to the full throttle position without load, the engine is running at high idle. The engine is running at the full load rpm when the throttle control lever is at the full throttle position with maximum rated load.**

### NOTICE

To help prevent engine damage, never exceed the high idle rpm. Overspeeding can result in serious damage to the engine. The engine can be operated at high idle without damage, but should never be allowed to exceed high idle rpm.



**Ammeter – This gauge indicates the amount of charge or discharge in the battery charging circuit. Operation of the indicator should be to the right side of “0” (zero).**



**Fuel Level – This gauge indicates the fuel level in the fuel tank. The fuel level gauge operates when the “START/STOP” switch is in the “ON” position.**



**Service Hour Meter – The gauge indicates operating time of the engine.**

## Features and Controls

i02593769

### Fuel Shutoff

The fuel shutoff solenoid is located on the fuel injection pump. When the fuel shutoff solenoid is activated, the solenoid moves the fuel rack to the "OFF" position.

---

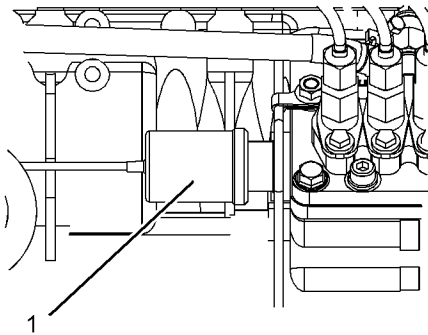

Illustration 32

g01305771

(1) Fuel shutoff solenoid

If an electronically controlled governor has been installed the governor operates the fuel rack in order to stop the engine.



# Engine Starting

i02194223

## Before Starting Engine

Before the engine is started, perform the required daily maintenance and any other periodic maintenance that is due. Refer to the Operation and Maintenance Manual, "Maintenance Interval Schedule" for more information.

- For the maximum service life of the engine, make a thorough inspection within the engine compartment before the engine is started. Look for the following items: oil leaks, coolant leaks, loose bolts and excessive dirt and/or grease. Remove any excess dirt and/or grease buildup. Repair any faults that were identified during the inspection.
- Inspect the cooling system hoses for cracks and for loose clamps.
- Inspect the alternator and accessory drive belts for cracks, breaks, and other damage.
- Inspect the wiring for loose connections and for worn wires or frayed wires.
- Check the fuel supply. Drain water from the water separator (if equipped). Open the fuel supply valve (if equipped).

### NOTICE

All valves in the fuel return line must be open before and during engine operation to help prevent high fuel pressure. High fuel pressure may cause filter housing failure or other damage.

If the engine has not been started for several weeks, fuel may have drained from the fuel system. Air may have entered the filter housing. Also, when fuel filters have been changed, some air pockets will be trapped in the engine. In these instances, prime the fuel system. Refer to the Operation and Maintenance Manual, "Fuel System - Prime" for more information on priming the fuel system.

### WARNING

**Engine exhaust contains products of combustion which may be harmful to your health. Always start and operate the engine in a well ventilated area and, if in an enclosed area, vent the exhaust to the outside.**

- Do not start the engine or move any of the controls if there is a "DO NOT OPERATE" warning tag or similar warning tag attached to the start switch or to the controls.
- Ensure that the areas around the rotating parts are clear.
- All of the guards must be put in place. Check for damaged guards or for missing guards. Repair any damaged guards. Replace damaged guards and/or missing guards.
- Disconnect any battery chargers that are not protected against the high current drain that is created when the electric starting motor is engaged. Check electrical cables and check the battery for poor connections and for corrosion.
- Reset all of the shutoffs or alarm components (if equipped).
- Check the engine lubrication oil level. Maintain the oil level between the "ADD" mark and the "FULL" mark on the engine oil level gauge.
- Check the coolant level. Observe the coolant level in the header tank (if equipped). Maintain the coolant level to the "FULL" mark on the header tank.
- If the engine is not equipped with a header tank maintain the coolant level within 13 mm (0.5 inch) of the bottom of the filler pipe. If the engine is equipped with a sight glass, maintain the coolant level in the sight glass.
- Observe the air cleaner service indicator (if equipped). Service the air cleaner when the yellow diaphragm enters the red zone, or when the red piston locks in the visible position.
- Ensure that any equipment that is driven by the engine has been disengaged from the engine. Minimize electrical loads or remove any electrical loads.

i04053911

## Before Starting Engine

Perform the required daily maintenance and other periodic maintenance before the engine is started. Inspect the engine compartment. This inspection can help prevent major repairs at a later date. Refer to the Operation and Maintenance Manual, "Maintenance Interval Schedule" for more information.

- Ensure that the engine has an adequate fuel supply.

## Operation Section Starting the Engine

- Open the fuel supply valve (if equipped).

If the engine has not been started for several weeks, fuel may have drained from the fuel system. Air may have entered the filter housing. Also, when fuel filters have been changed, some air pockets will be trapped in the engine. In these instances, prime the fuel system. Refer to the Operation and Maintenance Manual, "Fuel System - Prime" for more information on priming the fuel system. Also, check that the fuel specification is correct and that the fuel condition is correct. Refer to the Operation and Maintenance Manual, "Fuel Recommendations".

### **WARNING**

**Engine exhaust contains products of combustion which may be harmful to your health. Always start and operate the engine in a well ventilated area and, if in an enclosed area, vent the exhaust to the outside.**

- Do not start the engine or move any of the controls if there is a "DO NOT OPERATE" warning tag or similar warning tag attached to the start switch or to the controls.
- Reset all of the shutoffs or alarm components.
- Ensure that any driven equipment has been disengaged. Minimize electrical loads or remove any electrical loads.

i09851692

## Starting the Engine

### **WARNING**

**Do not use aerosol types of starting aids such as ether. Such use could result in an explosion and personal injury.**

Refer to the OEM manual for your type of controls. Use the following procedure to start the engine.

1. Move the throttle lever to the low idle position before you start the engine.

### **NOTICE**

Do not operate the glow plugs for more than 60 seconds at one time. Damage to the glow plugs could occur.

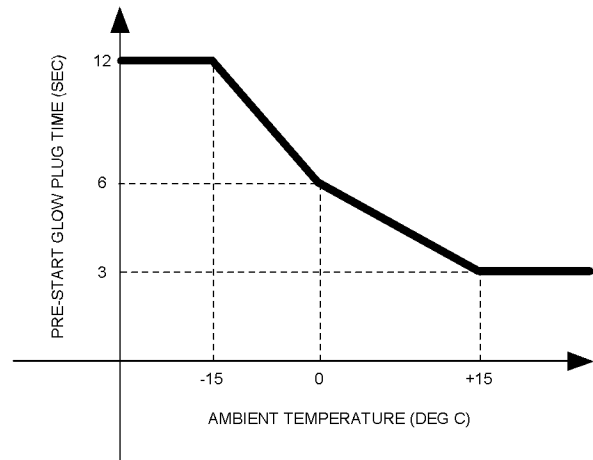

Illustration 33

g06201074

2. Turn the engine start switch to the HEAT position. Hold the engine start switch in the HEAT position for time shown in illustration 33. This action will activate the glow plugs and aid in the starting of the engine.

### **NOTICE**

Do not crank the engine for more than 30 seconds. Allow the electric starting motor to cool for two minutes before cranking the engine again.

3. When the glow plug indicator light is illuminated, turn the engine start switch to the START position and crank the engine.
4. When the engine starts, release the engine start switch.
5. Slowly move the throttle lever to the low idle position and allow the engine to idle. Refer to the Operation and Maintenance Manual, "After Starting Engine" topic.

**Note:** If the glow plug indicator light flashes rapidly for 2 to 3 seconds or fails to illuminate, a malfunction exists in the cold start system. Do not use ether or other starting fluids to start the engine.

6. If the engine does not start, release the engine start switch and allow the electric starting motor to cool. Then, repeat steps 2 through step 5.
7. Turn the engine start switch to the OFF position to stop the engine.

i02177935

## Starting with Jump Start Cables

### WARNING

**Improper jump start cable connections can cause an explosion resulting in personal injury.**

**Prevent sparks near the batteries. Sparks could cause vapors to explode. Do not allow jump start cable ends to contact each other or the engine.**

**Note:** If it is possible, first diagnose the reason for the starting failure. Make any necessary repairs. If the engine will not start only due to the condition of the battery, either charge the battery, or start the engine with jump start cables. The condition of the battery can be rechecked after the engine has been switched OFF.

### NOTICE

Using a battery source with the same voltage as the electric starting motor. Use **ONLY** equal voltage for jump starting. The use of higher voltage will damage the electrical system.

Do not reverse the battery cables. The alternator can be damaged. Attach ground cable last and remove first.

When using an external electrical source to start the engine, turn the generator set control switch to the "OFF" position. Turn all electrical accessories OFF before attaching the jump start cables.

Ensure that the main power switch is in the OFF position before attaching the jump start cables to the engine being started.

1. Turn the start switch to the OFF position. Turn off all the engine's accessories.
2. Connect one positive end of the jump start cable to the positive cable terminal of the discharged battery. Connect the other positive end of the jump start cable to the positive cable terminal of the electrical source.
3. Connect one negative end of the jump start cable to the negative cable terminal of the electrical source. Connect the other negative end of the jump start cable to the engine block or to the chassis ground. This procedure helps to prevent potential sparks from igniting the combustible gases that are produced by some batteries.
4. Start the engine.

5. Immediately after the stalled engine is started, disconnect the jump start cables in reverse order.

After jump starting, the alternator may not be able to fully recharge batteries that are severely discharged. The batteries must be replaced or charged to the correct voltage with a battery charger after the engine is stopped. Many batteries which are considered unusable are still rechargeable. Refer to Operation and Maintenance Manual, "Battery - Replace" and Testing and Adjusting Manual, "Battery - Test".

i06791278

## After Starting Engine

**Note:** In temperatures from 0°C to 60°C (32°F to 140°F), the warm-up time is approximately 3 minutes. In temperatures below 0°C (32°F), extra warm-up time may be required.

When the engine idles during warm-up, observe the following conditions:

- Check for any fluid or for any air leaks at idle rpm and at one-half full rpm (no load on the engine) before operating the engine under load. This action may not be possible in some applications.
- Operate the engine at low idle until all systems achieve operating temperatures. Check all gauges during the warm-up period.

Constant speed engines should be allowed to operate at low idle for 3 minutes before used at operational speed. If the low idle option is not available, then operate the engine at operational speed with no load for 2 minutes.

**Note:** Gauge readings should be observed and the data should be recorded frequently while the engine is operating. Comparing the data over time will help to determine normal readings for each gauge. Comparing data over time will also help detect abnormal operating developments. Significant changes in the readings should be investigated.

## Engine Operation

i06015869

### Engine Operation

Proper operation and maintenance are key factors in obtaining the maximum life and economy of the engine. If the directions in the Operation and Maintenance Manual are followed, costs can be minimized and engine service life can be maximized.

The engine can be operated at the rated rpm after the engine reaches operating temperature. The engine will reach normal operating temperature sooner during a low engine speed (rpm) and during a low-power demand. This procedure is more effective than idling the engine at no load. The engine should reach operating temperature in a few minutes.

Gauge readings should be observed and the data should be recorded frequently while the engine is operating. Comparing the data over time will help to determine normal readings for each gauge. Comparing data over time will also help detect abnormal operating developments. Significant changes in the readings should be investigated.

i02330149

### Fuel Conservation Practices

The efficiency of the engine can affect the fuel economy. Perkins design and technology in manufacturing provides maximum fuel efficiency in all applications. Follow the recommended procedures in order to attain optimum performance for the life of the engine.

- Avoid spilling fuel.

Fuel expands when the fuel is warmed up. The fuel may overflow from the fuel tank. Inspect fuel lines for leaks. Repair the fuel lines, as needed.

- Be aware of the properties of the different fuels. Use only the recommended fuels.
- Avoid unnecessary idling.

Shut off the engine rather than idle for long periods of time.

- Observe the air cleaner service indicator frequently. Keep the air cleaner elements clean.
- Maintain the electrical systems.

One damaged battery cell will overwork the alternator. This will consume excess power and excess fuel.

- Ensure that the drive belts are correctly adjusted. The drive belts should be in good condition.
- Ensure that all of the connections of the hoses are tight. The connections should not leak.
- Ensure that the driven equipment is in good working order.
- Cold engines consume excess fuel. Utilize heat from the jacket water system and the exhaust system, when possible. Keep cooling system components clean and keep cooling system components in good repair. Never operate the engine without water temperature regulators. All of these items will help maintain operating temperatures.

# Engine Stopping

i03756631

i06832774

## Stopping the Engine

---

### NOTICE

Stopping the engine immediately after it has been working under load, can result in overheating and accelerated wear of the engine components.

Avoid accelerating the engine prior to shutting it down.

Avoiding hot engine shutdowns will maximize turbo-charger shaft and bearing life.

---

**Note:** Individual applications will have different control systems. Ensure that the shutoff procedures are understood. Use the following general guidelines to stop the engine.

1. Remove the load from the engine. Reduce the engine speed (rpm) to low idle. Allow the engine to idle for 5 minutes to cool the engine.
  2. Stop the engine after the cool down period according to the shutoff system on the engine. Turn the ignition key switch to the OFF position. If necessary, refer to the instructions that are provided by the OEM.
- 

### NOTICE

Before any service or repairs are performed, ensure that the power supply to the engine is disconnected.

---

i07764840

## Emergency Stopping

---

### NOTICE

Emergency shutoff controls are for EMERGENCY use ONLY. DO NOT use emergency shutoff devices or controls for normal stopping procedure.

---

The Original Equipment Manufacturer (OEM) may have equipped the application with an emergency stop button. For more information about the emergency stop button, refer to the OEM information.

Ensure that any components for the external system that support the engine operation are secured after the engine is stopped.

## After Stopping Engine

**Note:** Before you check the engine oil, do not operate the engine for at least 10 minutes in order to allow the engine oil to return to the oil pan.

- Check the crankcase oil level. Maintain the oil level between the “MIN” mark and the “MAX” mark on the engine oil level gauge.
  - If necessary, perform minor adjustments. Repair any leaks and tighten any loose bolts.
  - If the engine is equipped with a service hour meter, note the reading. Perform the maintenance that is in the Operation and Maintenance Manual, “Maintenance Interval Schedule”.
  - Fill the fuel tank in order to help prevent accumulation of moisture in the fuel. Do not overfill the fuel tank.
- 

### NOTICE

Only use antifreeze/coolant mixtures recommended in the Refill Capacities and Recommendations topic that is in this Operation and Maintenance Manual. Failure to do so can cause engine damage.

---

- Allow the engine to cool. Check the coolant level.
- If freezing temperatures are expected, check the coolant for correct antifreeze protection. The cooling system must be protected against freezing to the lowest expected outside temperature. Add the correct coolant/water mixture, if necessary.
- Perform all required periodic maintenance on all driven equipment. This maintenance is outlined in the instructions from the OEM.

## Cold Weather Operation

i05927231

### Cold Weather Operation

Perkins Diesel Engines can operate effectively in cold weather. During cold weather, the starting and the operation of the diesel engine is dependent on the following items:

- The type of fuel that is used
- The viscosity of the engine oil
- The operation of the glow plugs
- Optional Cold starting aid
- Battery condition
- Ambient air temperature and altitude
- Parasitic load of the application
- Application hydraulic and transmission oil viscosities

This section will cover the following information:

- Potential problems that are caused by cold-weather operation
- Suggest steps which can be taken in order to minimize starting problems and operating problems when the ambient air temperature is between 0° to -40 °C (32° to 40 °F).

The operation and maintenance of an engine in freezing temperatures is complex . This complexity is because of the following conditions:

- Weather conditions
- Engine applications

Recommendations from your Perkins dealer or your Perkins distributor are based on past proven practices. The information that is contained in this section provides guidelines for cold-weather operation.

### Hints for Cold Weather Operation

- If the engine will start, operate the engine until a minimum operating temperature of 81 °C (177.8 °F) is achieved. Achieving operating temperature will help prevent the intake valves and exhaust valves from sticking.

- The cooling system and the lubrication system for the engine do not lose heat immediately upon shutdown. This means that an engine can be shut down for a period of time, and the engine can still be able to start readily.
- Install the correct specification of engine lubricant before the beginning of cold weather.
- Check all rubber parts (hoses, fan drive belts.) weekly.
- Check all electrical wiring and connections for any fraying or damaged insulation.
- Keep all batteries fully charged and warm.
- Fill the fuel tank at the end of each shift.
- Check the air cleaners and the air intake daily. Check the air intake more often when you operate in snow.
- Ensure that the glow plugs are in working order. Refer to Testing and Adjusting Manual, "Glow Plug - Test".

#### **WARNING**

**Personal injury or property damage can result from alcohol or starting fluids.**

**Alcohol or starting fluids are highly flammable and toxic and if improperly stored could result in injury or property damage.**

---

#### **WARNING**

**Do not use aerosol types of starting aids such as ether. Such use could result in an explosion and personal injury.**

---

- For jump starting with cables in cold weather, refer to the Operation and Maintenance Manual, "Starting with Jump Start Cables." for instructions.

## Viscosity of the Engine Lubrication Oil

Correct engine oil viscosity is essential. Oil viscosity affects the amount of torque that is needed to crank the engine. Refer to this Operation and Maintenance Manual, "Fluid Recommendations" for the recommended viscosity of oil.

## Recommendations for the Coolant

Provide cooling system protection for the lowest expected outside temperature. Refer to this Operation and Maintenance Manual, "Fluid Recommendations" for the recommended coolant mixture.

In cold weather, check the coolant often for the correct glycol concentration in order to ensure adequate freeze protection.

## Engine Block Heaters

Engine block heaters (if equipped) heat the engine jacket water that surrounds the combustion chambers. This heat provides the following functions:

- Startability is improved.
- Warm up time is reduced.

An electric block heater can be activated once the engine is stopped. An effective block heater is typically a 1250/1500 W unit. Consult your Perkins dealer or your Perkins distributor for more information.

## Idling the Engine

When idling after the engine is started in cold weather, increase the engine rpm from 1000 to 1200 rpm. This increase in RPM will warm up the engine more quickly. Maintaining an elevated low idle speed for extended periods will be easier with the installation of a hand throttle. The engine should not be "raced" in order to speed up the warm-up process.

While the engine is idling, the application of a light load (parasitic load) will assist in achieving the minimum operating temperature. The minimum operating temperature is 82 °C (179.6 °F).

## Recommendations for Coolant Warm Up

Warm up an engine that has cooled below normal operating temperatures due to inactivity. The warm-up should be performed before the engine is returned to full operation. During operation in very cold temperature conditions, damage to engine valve mechanisms can result from engine operation for short intervals. This action can happen if the engine is started and the engine is stopped many times without being operated in order to warm up completely.

When the engine is operated below normal operating temperatures, fuel and oil are not completely burned in the combustion chamber. This fuel and oil causes soft carbon deposits to form on the valve stems. Generally, the deposits do not cause problems and the deposits are burned off during operation at normal engine operating temperatures.

When the engine is started and the engine is stopped many times without being operated in order to warm up completely, the carbon deposits become thicker. This action can cause the following problems:

- Free operation of the valves is prevented.
- Valves become stuck.
- Pushrods may become bent.
- Other damage to valve train components can result.

For this reason, when the engine is started, the engine must be operated until the coolant temperature is 71 °C (160 °F) minimum. Carbon deposits on the valve stems will be kept at a minimum. The free operation of the valves and the valve components will be maintained.

In addition, the engine must be thoroughly warmed in order to keep other engine parts in better condition and the service life of the engine will be generally extended. Lubrication will be improved. There will be less acid and less sludge in the oil. This lubrication will provide longer service life for the engine bearings, the piston rings, and other parts. However, limit unnecessary idle time to 10 minutes in order to reduce wear and unnecessary fuel consumption.

## The Water Temperature Regulator and Insulated Heater Lines

The engine is equipped with a water temperature regulator. When the engine coolant is below the correct operating temperature, jacket water circulates through the engine cylinder block and into the engine cylinder head. The coolant then returns to the cylinder block via an internal passage that bypasses the valve of the coolant temperature regulator. This system ensures that coolant flows around the engine under cold operating conditions. The water temperature regulator begins to open when the engine jacket water has reached the correct minimum operating temperature. As the jacket water coolant temperature rises above the minimum operating temperature the water temperature regulator opens further allowing more coolant through the radiator to dissipate excess heat.

The progressive opening of the water temperature regulator operates the progressive closing of the bypass passage between the cylinder block and head. This system ensures maximum coolant flow to the radiator in order to achieve maximum heat dissipation.

**Note:** Perkins discourages the use of all air flow restriction devices such as radiator shutters. Restriction of the air flow can result in the following: high exhaust temperatures, power loss, excessive fan usage and reduction in fuel economy.

A cab heater is beneficial in very cold weather. The feed from the engine and the return lines from the cab should be insulated in order to reduce heat loss to the outside air.

## Insulating the Air Inlet and Engine Compartment

When temperatures below  $-18^{\circ}\text{C}$  ( $-0^{\circ}\text{F}$ ) will be frequently encountered, an air cleaner inlet that is located in the engine compartment may be specified. An air cleaner that is located in the engine compartment may also minimize the entry of snow into the air cleaner. Also, heat that is rejected by the engine helps to warm the intake air.

Additional heat can be retained around the engine by insulating the engine compartment.

i05927268

## Fuel and the Effect from Cold Weather

**Note:** Only use grades of fuel that are recommended by Perkins. Refer to this Operation and Maintenance Manual, "Fluid Recommendations".

Properties of the diesel fuel can have a significant effect on the engine cold start capability. Critical to the low temperature properties of diesel fuel is the acceptability for the minimum ambient temperature the engine is expected to see in operation. Following properties are used to define fuels low temperature capability:

- Cloud point
- Pour point
- Cold Filter Plugging Point (CFPP)

The cloud point of the fuel is the temperature at which waxes naturally found in diesel fuel begins to form crystals. The cloud point of the fuel must be below lowest ambient temperature to prevent filters from plugging.

CFPP is a temperature at which a particular fuel will pass through a standardized filtration device. The CFPP gives an estimate of the lower operability temperature of fuel.

Pour point is the last temperature before the fuel flow stops and waxing of the fuel will start.

Be aware of these properties when diesel fuel is purchased. Consider the average ambient air temperature for the engines application. Engines that are fueled in one climate may not operate well if the engines are shipped to colder climate. Problems can result due to changes in temperature.

Before troubleshooting for low power or for poor performance in the winter, check the fuel for waxing.

The following components can provide a means of minimizing fuel waxing problems in cold weather:

- Fuel heaters, which may be an OEM option
- Fuel line insulation, which may be an OEM option

Winter and arctic grades of diesel fuel are available in the countries and territories with severe winters. For more information refer to the Operation and Maintenance Manual, "Cold Weather Operation"

Another important fuel property which can affect cold start and operation of diesel engine is cetane number. For more information refer to the Operation and Maintenance Manual, "Fluid Recommendations".



i01903588

## Fuel Related Components in Cold Weather

### Fuel Tanks

Condensation can form in partially filled fuel tanks. Top off the fuel tanks after you operate the engine.

Fuel tanks should contain some provision for draining water and sediment from the bottom of the tanks. Some fuel tanks use supply pipes that allow water and sediment to settle below the end of the fuel supply pipe.

Some fuel tanks use supply lines that take fuel directly from the bottom of the tank. If the engine is equipped with this system, regular maintenance of the fuel system filter is important.

Drain the water and sediment from any fuel storage tank at the following intervals: weekly, oil changes and refueling of the fuel tank. This will help prevent water and/or sediment from being pumped from the fuel storage tank and into the engine fuel tank.

### Fuel Filters

It is possible that a primary fuel filter is installed between the fuel tank and the engine fuel inlet. After you change the fuel filter, always prime the fuel system in order to remove air bubbles from the fuel system. Refer to the Operation and Maintenance Manual in the Maintenance Section for more information on priming the fuel system.

The micron rating and the location of a primary fuel filter is important in cold weather operation. The primary fuel filter and the fuel supply line are the most common components that are affected by cold fuel.

### Fuel Heaters

**Note:** The OEM may equip the application with fuel heaters. If this is the case, disconnect an electric type of fuel heater in warm weather in order to prevent overheating of the fuel. If the type of fuel heater is a heat exchanger, the OEM should have included a bypass for warm weather. Ensure that the bypass is operational during warm weather in order to prevent overheating of the fuel.

For more information about fuel heaters (if equipped), refer to the OEM information.

# Maintenance Section

## Refill Capacities

i06812527

## Refill Capacities

### Lubrication System

The refill capacities for the engine crankcase reflect the approximate capacity of the crankcase or sump plus standard oil filters. Auxiliary oil filter systems will require more oil. Refer to the OEM specifications for the capacity of the auxiliary oil filter. Refer to the Operation and Maintenance Manual, "Maintenance Section" for more information on Lubricant Specifications.

#### 402D-05 Engine

Table 11

402D-05 Engine Refill Capacities		
Compartment or System	Minimum	Maximum
Crankcase Oil Sump <sup>(1)</sup>	1.61 L (1.7 qt)	2.01 L (2.1 qt)
Total Lubrication System <sup>(2)</sup>		

- (1) These values are the approximate capacities for the crankcase oil sump which includes the standard factory installed oil filters. Engines with auxiliary oil filters will require more oil. Refer to the OEM specifications for the capacity of the auxiliary oil filter.
- (2) The Total Lubrication System includes the capacity for the Crankcase Oil Sump plus the capacity of factory installed oil filters and other filters added to the lubrication system. Enter the value for the capacity of the Total Lubrication System in this row.

#### 403D-07 Engine

Table 12

403D-07 Engine Refill Capacities		
Compartment or System	Minimum	Maximum
Crankcase Oil Sump <sup>(1)</sup>	2.35 L (2.5 qt)	3.05 L (3.2 qt)
Total Lubrication System <sup>(2)</sup>		

- (1) These values are the approximate capacities for the crankcase oil sump which includes the standard factory installed oil filters. Engines with auxiliary oil filters will require more oil. Refer to the OEM specifications for the capacity of the auxiliary oil filter.

(Table 12, contd)

- (2) The Total Lubrication System includes the capacity for the Crankcase Oil Sump plus the capacity of factory installed oil filters and other filters added to the lubrication system. Enter the value for the capacity of the Total Lubrication System in this row.

#### 403D-11 Engine Oil Capacity

Table 13

403D-11 Engine Refill Capacities		
Compartment or System	Minimum	Maximum
Crankcase Oil Sump <sup>(1)</sup>	3.4 L (3.6 qt)	4.4 L (4.6494 qt)
Total Lubrication System <sup>(2)</sup>		

- (1) These values are the approximate capacities for the crankcase oil sump which includes the standard factory installed oil filters. Engines with auxiliary oil filters will require more oil. Refer to the OEM specifications for the capacity of the auxiliary oil filter.
- (2) The Total Lubrication System includes the capacity for the Crankcase Oil Sump plus the capacity of factory installed oil filters and other filters added to the lubrication system. Enter the value for the capacity of the Total Lubrication System in this row.

#### 403D-15 and 403D-15T Engines

Table 14

403D-15 and 403D-15T Engines Refill Capacities		
Compartment or System	Minimum	Maximum
Crankcase Oil Sump <sup>(1)</sup>	4.5 L (4.8 qt)	6 L (6.3 qt)
Total Lubrication System <sup>(2)</sup>		

- (1) These values are the approximate capacities for the crankcase oil sump which includes the standard factory installed oil filters. Engines with auxiliary oil filters will require more oil. Refer to the OEM specifications for the capacity of the auxiliary oil filter.
- (2) The Total Lubrication System includes the capacity for the Crankcase Oil Sump plus the capacity of factory installed oil filters and other filters added to the lubrication system. Enter the value for the capacity of the Total Lubrication System in this row.

#### 403D-17 Engine

Table 15

403D-17 Engine Refill Capacities		
Compartment or System	Minimum	Maximum
Crankcase Oil Sump <sup>(1)</sup>	4.5 L (4.8 qt)	6 L (6.3 qt)
Total Lubrication System <sup>(2)</sup>		

(continued)

(continued)

(Table 15, contd)

- (1) These values are the approximate capacities for the crankcase oil sump which includes the standard factory installed oil filters. Engines with auxiliary oil filters will require more oil. Refer to the OEM specifications for the capacity of the auxiliary oil filter.
- (2) The Total Lubrication System includes the capacity for the Crankcase Oil Sump plus the capacity of factory installed oil filters and other filters added to the lubrication system. Enter the value for the capacity of the Total Lubrication System in this row.

## 404D-15 Engine

Table 16

404D-15 Engine Refill Capacities		
Compartment or System	Minimum	Maximum
Crankcase Oil Sump <sup>(1)</sup>	3.9 L (4.1211 qt)	5.6 L (5.9175 qt)
Total Lubrication System <sup>(2)</sup>		

- (1) These values are the approximate capacities for the crankcase oil sump which includes the standard factory installed oil filters. Engines with auxiliary oil filters will require more oil. Refer to the OEM specifications for the capacity of the auxiliary oil filter.
- (2) The Total Lubrication System includes the capacity for the Crankcase Oil Sump plus the capacity of factory installed oil filters and other filters added to the lubrication system. Enter the value for the capacity of the Total Lubrication System in this row.

## 404D-22, 404D-22T, and 404D-22TA Engines

Table 17

404D-22,404D-22T, and 404D-22TA Engines Refill Capacities		
Compartment or System	Minimum	Maximum
Crankcase Oil Sump <sup>(1)</sup>	8.9 L (9.4 qt)	10.6 L (11.2 qt)
Total Lubrication System <sup>(2)</sup>		

- (1) More than one style of sump may be used on these engines. Use these values to estimate the refill capacity. Use the engine oil level gauge to fill the engine to the correct oil level. Record the result in this table. These values are the approximate capacities for the Crankcase Oil Sump which includes the standard factory installed oil filters. Engines with auxiliary oil filters will require more oil. Refer to the OEM specifications for the capacity of the auxiliary oil filter.

(continued)

(Table 17, contd)

- (2) The Total Lubrication System includes the capacity for the Crankcase Oil Sump plus the capacity of factory installed oil filters and other filters added to the lubrication system. Enter the value for the capacity of the Total Lubrication System in this row.

## Cooling System

To maintain the cooling system, the Total Cooling System capacity must be known. The approximate capacity is for the engine cooling system. External System capacities will vary among applications. Refer to the OEM specifications for the External System capacity. This capacity information will be needed to determine the amount of coolant that is required for the Total Cooling System.

## 402D-05 Engine

Table 18

402D-05 Engine Refill Capacities		
Compartment or System	Liters	Quarts
Engine Only	1.1	1.2
External System Per OEM <sup>(1)</sup>		
Total Cooling System <sup>(2)</sup>		

- (1) The External System includes a radiator or an expansion tank with the following components: heat exchanger and piping. Refer to the OEM specifications. Enter the value for the capacity of the External System in this row.
- (2) The Total Cooling System capacity includes the capacity of the Engine plus the External System. Enter the value for the capacity of the Total Cooling System in this row.

## 403D-07 Engine

Table 19

403D-07 Engine Refill Capacities		
Compartment or System	Liters	Quarts
Engine Only	1.2	1.3
External System Per OEM <sup>(1)</sup>		
Total Cooling System <sup>(2)</sup>		

- (1) The External System includes a radiator or an expansion tank with the following components: heat exchanger and piping. Refer to the OEM specifications. Enter the value for the capacity of the External System in this row.
- (2) The Total Cooling System capacity includes the capacity of the Engine plus the External System. Enter the value for the capacity of the Total Cooling System in this row.

**403D-11 Engine**

Table 20

<b>403D-11 Engine Refill Capacities</b>		
<b>Compartment or System</b>	<b>Liters</b>	<b>Quarts</b>
Engine Only	1.9	2.0
External System Per OEM <sup>(1)</sup>		
Total Cooling System <sup>(2)</sup>		

- (1) The External System includes a radiator or an expansion tank with the following components: heat exchanger and piping. Refer to the OEM specifications. Enter the value for the capacity of the External System in this row.
- (2) The Total Cooling System capacity includes the capacity of the Engine plus the External System. Enter the value for the capacity of the Total Cooling System in this row.

**403D-15 and 403D-15T Engines**

Table 21

<b>403D-15 and 403D-15T Engines Refill Capacities</b>		
<b>Compartment or System</b>	<b>Liters</b>	<b>Quarts</b>
Engine Only	2.6	2.7
External System Per OEM <sup>(1)</sup>		
Total Cooling System <sup>(2)</sup>		

- (1) The External System includes a radiator or an expansion tank with the following components: heat exchanger and piping. Refer to the OEM specifications. Enter the value for the capacity of the External System in this row.
- (2) The Total Cooling System capacity includes the capacity of the Engine plus the External System. Enter the value for the capacity of the Total Cooling System in this row.

**404D-15 Engine**

Table 22

<b>404D-15 Engine Refill Capacities</b>		
<b>Compartment or System</b>	<b>Liters</b>	<b>Quarts</b>
Engine Only	2.4	2.5
External System Per OEM <sup>(1)</sup>		
Total Cooling System <sup>(2)</sup>		

- (1) The External System includes a radiator or an expansion tank with the following components: heat exchanger and piping. Refer to the OEM specifications. Enter the value for the capacity of the External System in this row.
- (2) The Total Cooling System capacity includes the capacity of the Engine plus the External System. Enter the value for the capacity of the Total Cooling System in this row.

**404D-22, 404D-22T, and 404D-22TA Engines**

Table 23

<b>404D-22,404D-22T, and 404D-22TA Engines Refill Capacities</b>		
<b>Compartment or System</b>	<b>Liters</b>	<b>Quarts</b>
Engine Only	3.6	3.8
External System Per OEM <sup>(1)</sup>		
Total Cooling System <sup>(2)</sup>		

- (1) The External System includes a radiator or an expansion tank with the following components: heat exchanger and piping. Refer to the OEM specifications. Enter the value for the capacity of the External System in this row.
- (2) The Total Cooling System capacity includes the capacity for the Engine plus the External System. Enter the value for the capacity of the Total Cooling System in this row.

i02959101

**Fluid Recommendations  
(Fuel Specification)**

- **Glossary**
- ISO International Standards Organization
- ASTM American Society for Testing and Materials
- HFRR High Frequency Reciprocating Rig for Lubricity testing of diesel fuels
- FAME Fatty Acid Methyl Esters
- CFR Co-ordinating Fuel Research
- LSD Low Sulfur Diesel
- ULSD Ultra Low Sulfur Diesel
- RME Rape Methyl Ester
- SME Soy Methyl Ester
- EPA Environmental Protection Agency of the United States

**General Information****NOTICE**

Every attempt is made to provide accurate, up to date information. By use of this document you agree that Perkins Engines Company Limited is not responsible for errors or omissions.

**NOTICE**

These recommendations are subject to change without notice. Contact your local Perkins distributor for the most up to date recommendations.

**Diesel Fuel Requirements**

Satisfactory engine performance is dependent on the use of a good quality fuel. The use of a good quality fuel will give the following results: long engine life and acceptable exhaust emissions levels. The fuel must meet the minimum requirements that are stated in tables 24 , 25 and 26 .

**NOTICE**

The footnotes are a key part of the Perkins Specification for Distillate Diesel Fuel Table. Read ALL of the footnotes.

Table 24

Perkins Specification for Distillate Diesel Fuel <sup>(1)</sup>				
Property	UNITS	Requirements	"ASTM" Test	"ISO" Test
Aromatics	%Volume	35% maximum	D1319	"ISO"3837
Ash	%Weight	0.02% maximum	D482	"ISO"6245
Carbon Residue on 10% Bottoms	%Weight	0.35% maximum	D524	"ISO"4262
Cetane Number <sup>(2)</sup>	-	40 minimum	D613/D6890	"ISO"5165
Cloud Point	°C	The cloud point must not exceed the lowest expected ambient temperature.	D2500	"ISO"3015
Copper Strip Corrosion	-	No. 3 maximum	D130	"ISO"2160
Density at 15 °C (59 °F) <sup>(3)</sup>	Kg / M <sup>3</sup>	801 minimum and 876 maximum	No equivalent test	"ISO 3675 ""ISO 12185"
Distillation	°C	10% at 282 °C (539.6 °F) maximum 90% at 360 °C (680 °F) maximum	D86	"ISO"3405
Flash Point	°C	legal limit	D93	"ISO"2719
Thermal Stability	-	Minimum of 80% reflectance after aging for 180 minutes at 150 °C (302 °F)	D6468	No equivalent test
Pour Point	°C	6 °C (42.8 °F) minimum below ambient temperature	D97	"ISO"3016
Sulfur <sup>(1)(4)</sup>	%mass	The level of sulfur that is in the fuel is controlled by emissions regulations. Refer to Tables 25 and 26 for more information.	D5453/D26222	"ISO 20846 ""ISO 20884"

(continued)

Maintenance Section  
Fuel Specification

(Table 24, contd)

Kinematic Viscosity <sup>(5)</sup>	"MM" <sup>24</sup> /S (cSt)"	The viscosity of the fuel that is delivered to the fuel injection pump. "1.4 minimum/ 4.5 maximum"	D445	"ISO"3405
Water and sediment	% weight	0.1% maximum	D1796	"ISO"3734
Water	% weight	0.1% maximum	D1744	No equivalent test
Sediment	% weight	0.05% maximum	D473	"ISO"3735
Gums and Resins <sup>(6)</sup>	mg/100mL	10 mg per 100 mL maximum	D381	"ISO"6246
Lubricity corrected wear scar diameter at 60 °C (140 °F). <sup>(7)</sup>	mm	0.46 maximum	D6079	"ISO"12156-1

- (1) This specification includes the requirements for Ultra Low Sulfur Diesel (ULSD). ULSD fuel will have  $\leq 15$  ppm (0.0015%) sulfur. Refer to "ASTM D5453", "ASTM D2622", or "ISO 20846, ISO 20884" test methods. This specification includes the requirements for Low Sulfur Diesel (LSD). LSD fuel will have  $\leq 500$  ppm (0.05%) sulfur. Refer to following: "ASTM 5453, ASTM D2622", "ISO 20846" and "ISO 20884 test methods". Refer to Tables 25 and 26 .
- (2) A fuel with a higher cetane number is recommended in order to operate at a higher altitude or in cold weather.
- (3) "Via standards tables, the equivalent API gravity for the minimum density of 801 kg / m<sup>3</sup> (kilograms per cubic meter) is 45 and for the maximum density of 876 kg / m<sup>3</sup> is 30".
- (4) Regional regulations, national regulations or international regulations can require a fuel with a specific sulfur limit. Consult all applicable regulations before selecting a fuel for a given engine application. Perkins fuel systems and engine components can operate on high sulfur fuels in territories that are non-emissions regulated. Fuel sulfur levels affect exhaust emissions. High sulfur fuels also increase the potential for corrosion of internal components. Fuel sulfur levels above 0.5% may significantly shorten the oil change interval. For additional information, refer to this manual, "Fluid recommendations (General lubricant Information)".
- (5) The values of the fuel viscosity are the values as the fuel is delivered to the fuel injection pumps. Fuel should also meet the minimum viscosity requirement and the fuel should meet the maximum viscosity requirements at 40 °C (104 °F) of either the "ASTM D445" test method or the "ISO 3104" test method. If a fuel with a low viscosity is used, cooling of the fuel may be required to maintain 1.4 cSt or greater viscosity at the fuel injection pump. Fuels with a high viscosity might require fuel heaters in order to lower the viscosity to 4.5 cSt at the fuel injection pump.
- (6) Follow the test conditions and procedures for gasoline (motor).
- (7) The lubricity of a fuel is a concern with low sulfur and ultra low sulfur fuel. To determine the lubricity of the fuel, use the "ISO 12156-1 or ASTM D6079 High Frequency Reciprocating Rig (HFRR)" test. If the lubricity of a fuel does not meet the minimum requirements, consult your fuel supplier. Do not treat the fuel without consulting the fuel supplier. Some additives are not compatible. These additives can cause problems in the fuel system.

#### NOTICE

Operating with fuels that do not meet the Perkins recommendations can cause the following effects: Starting difficulty, poor combustion, deposits in the fuel injectors, reduced service life of the fuel system, deposits in the combustion chamber and reduced service life of the engine.

Cetane numbers in excess of 45 are normally expected from current diesel fuel. However, a cetane number of 40 may be experienced in some territories. The United States of America is one of the territories that can have a low cetane value. A minimum cetane value of 40 is required during average starting conditions. A higher cetane value may be required for operations at high altitudes or in cold weather operations.

## Diesel Fuel Characteristics

### Perkins Recommendation

#### Cetane Number

Fuel that has a high cetane number will give a shorter ignition delay. This will produce a better ignition quality. Cetane numbers are derived for fuels against proportions of cetane and heptamethylnonane in the standard CFR engine. Refer to "ISO 5165" for the test method.

Fuel with a low cetane number can be the root cause of problems during cold start.

#### Viscosity

Viscosity is the property of a liquid of offering resistance to shear or flow. Viscosity decreases with increasing temperature. This decrease in viscosity follows a logarithmic relationship for normal fossil fuel. The common reference is to kinematic viscosity. This is the quotient of the dynamic viscosity that is divided by the density. The determination of kinematic viscosity is normally by readings from gravity flow viscometers at standard temperatures. Refer to "ISO 3104" for the test method.

The viscosity of the fuel is significant because fuel serves as a lubricant for the fuel system components. Fuel must have sufficient viscosity in order to lubricate the fuel system in both extremely cold temperatures and extremely hot temperatures. If the kinematic viscosity of the fuel is lower than 1.4 cSt at the fuel injection pump damage to the fuel injection pump can occur. This damage can be excessive scuffing and seizure. Low viscosity may lead to difficult hot restarting, stalling and loss of performance. High viscosity may result in seizure of the pump.

Perkins recommends kinematic viscosities of 1.4 and 4.5 mm<sup>2</sup>/sec that is delivered to the fuel injection pump.

### Density

Density is the mass of the fuel per unit volume at a specific temperature. This parameter has a direct influence on engine performance and a direct influence on emissions. This determines the heat output from a given injected volume of fuel. This is generally quoted in the following kg/m<sup>3</sup> at 15 °C (59 °F).

Perkins recommends a value of density of 841 kg/m<sup>3</sup> in order to obtain the correct power output. Lighter fuels are acceptable but these fuels will not produce the rated power.

### Sulfur

The level of sulfur is governed by emissions legislations. Regional regulation, national regulations or international regulations can require a fuel with a specific sulfur limit. The sulfur content of the fuel and the fuel quality must comply with all existing local regulations for emissions.

Tables 25 and 26 list the guidelines for the correct sulfur level for specific territories. Consult all applicable regulations before selecting the fuel for a given engine application.

Table 25

Territory	Fuel Requirements from 2007		
EPA	Low Sulfur (500 ppm) maximum		
EC	Sulfur/Power	Low sulfur (300 ppm) maximum for less than or equal to 19 kW	Sulphur (1000 ppm) maximum for greater than 19 kW
	Models	402D-05 and 403D-07	403D-11, 403D-15, 403D-15T, 403D-17, 404D-15, 404D-22, 404D-22T and 404D-22TA
Non-Regulated Territories	Sulfur limit of less than 4000 ppm		

Table 26

Territory	Fuel Requirements from 2010		
EPA	Ultra Low Sulfur (15 ppm) maximum		
EC	Sulfur/Power	Ultra Low sulphur (10 ppm) maximum for less than or equal to 37 kW	Low sulphur (300 ppm) maximum for greater than 37 kW
	Models	402D-05, 403D-07, 403D-11, 403D-15, 403D-15T, 403D-17, 404D-15	404D-22, 404D-22T and 404D-22TA
Non Regulated Territories	Sulfur limit of less than 4000 ppm		

By using the test methods “ASTM D5453, ASTM D2622, or ISO 20846 ISO 20884”, the content of sulfur in low sulfur diesel (LSD) fuel must be below 500 PPM 0.05%. By using the test methods “ASTM D5453, ASTM D2622, or ISO 20846 ISO 20884”, the content of sulfur in ultra low sulfur (ULSD) fuel must be below 15 PPM 0.0015%. The lubricity of these fuels must not exceed wear scar diameter of 0.46 mm (0.0181 inch). The fuel lubricity test must be performed on a HFRR, operated at 60 °C (140 °F). Refer to “ISO 12156-1”.

In some parts of the world and for some applications, high sulfur fuels above 0.5% by mass might only be available. Fuel with very high sulfur content can cause engine wear. High sulfur fuel will have a negative impact on emissions of particulates. High sulfur fuel can be used provided that the local emissions legislation will allow the use. High sulfur fuel can be used in countries that do not regulate emissions.

When only high sulfur fuels are available, it will be necessary that high alkaline lubricating oil is used in the engine or that the lubricating oil change interval is reduced. Refer to this Operation and Maintenance Manual, “Fluid Recommendations (General Lubrication Information)” for information on sulfur in fuel.

### Lubricity

This is the capability of the fuel to prevent pump wear. The fluid's lubricity describes the ability of the fluid to reduce the friction between surfaces that are under load. This ability reduces the damage that is caused by friction. Fuel injection systems rely on the lubricating properties of the fuel. Until fuel sulfur limits were mandated, the fuel's lubricity was generally believed to be a function of fuel viscosity.

Maintenance Section  
Fuel Specification

The lubricity has particular significance to the current low viscosity fuel, low sulfur fuel and low aromatic fossil fuel. These fuels are made in order to meet stringent exhaust emissions. A test method for measuring the lubricity of diesel fuels has been developed and the test is based on the HFRR method that is operated at 60 °C (140 °F). Refer to "ISO 12156 part 1 and CEC document F06-A-96" for the test method.

Lubricity wear scar diameter of 0.46 mm (0.0181 inch) MUST NOT be exceeded. The fuel lubricity test must be performed on a HFRR, operated at 60 °C (140 °F). Refer to "ISO 12156-1".

Fuel additives can enhance the lubricity of a fuel. Contact your fuel supplier for those circumstances when fuel additives are required. Your fuel supplier can make recommendations for additives to use and for the proper level of treatment. Refer to "Fuel Additive" for more information.

## Distillation

This is an indication of the mixture of different hydrocarbons in the fuel. A high ratio of light weight hydrocarbons can affect the characteristics of combustion.

## Classification of the Fuels

Diesel engines have the ability to burn a wide variety of fuels. These fuels are divided into four general groups: Ref to table 27

Table 27

Fuel Groups	Classification	
Group 1	Preferred fuels	Full life of the Product
Group 2	Permissible fuels	These fuels MAY cause reduced engine life and performance
Group 3	Aviation fuels	These fuels WILL cause reduced engine life and performance
Group 4	Biodiesel	

### Group 1 Specifications (Preferred Fuels)

This group of fuel specifications is considered acceptable:

- EN590 DERV Grade A, B, C, E, F, Class, 0, 1, 2, 3 and 4
- "ASTM D975", Grade 2D S15 and Grade 2D S500
- "JIS K2204 Grades 1,2,3 and Special Grade 3"  
This grade of fuel must meet the minimum lubricity requirements that are stated in table 24 .

- "BS2869 Class A2" Off-Highway Gas Oil Red Diesel

**Note:** BS2869 can only be used if the sulfur level meets the specifications that are listed in tables 25 and 26 . An analysis of a sample of fuel must be conducted in order to check the sulfur level.

**Note:** The use of LSD fuel and the use of ULSD fuel is acceptable provided that the fuels meet the minimum requirements that are stated in tables 24 , 25 and 26 . The lubricity of these fuels must not exceed wear scar diameter of 0.46 mm (0.0181 inch). The lubricity test must be performed on a HFRR, operated at 60 °C (140 °F). Refer to "ISO 12156-1". By using the test methods "ASTM D5453, ASTM D2622, or ISO 20846 ISO 20884", the content of sulfur in LSD fuel must be below 500 PPM 0.05%. By using the test methods "ASTM D5453, ASTM D2622, or ISO 20846 ISO 20884", the content of sulfur in ULSD fuel must be below 15 PPM 0.0015%.

### Group 2 Specifications (Permissible Fuels)

This group of fuel specifications is considered acceptable, but these fuels MAY reduce the engine life and performance.

- "ASTM D975", Grade 1D S15 and Grade 1D S500
- "JP7 (MIL-T-38219)"
- "NATO F63"

**Note:** JP7 and NATO F63 can only be used if the sulfur level meets the specifications that are listed in tables 25 and 26 . An analysis of a sample of fuel must be conducted in order to check the sulfur level.

### Group 3 Specifications (Aviation Fuels)

This group of fuel specification must be used only with the appropriate fuel additive. This fuel WILL reduce engine life and performance.

- "NATO F34 (MIL-DTL-83133E)"
- "NATO F35 (MIL-DTL-83133E)"
- "NATO JP8 (MIL-DTL-83133E)"
- "NATO F-44 (MIL-DTL-5624U)"
- "NATO JP5 (MIL-DTL-5624U)"
- "Jet A (ASTM D1655)"
- "Jet A1 (ASTM D1655)"



**Note:** All the above fuels can ONLY be used if the sulfur level meets the specifications that are listed in tables 25 and 26 . An analysis of a sample of fuel must be conducted in order to check the sulfur level.

**Note:** These fuels are only acceptable provided that these fuels are used with an appropriate fuel additive. These fuels must meet the requirements that are stated in tables 24 , 25 and 26 . Fuel samples should be analyzed for the compliance. These fuels MUST NOT exceed lubricity wear scar diameter of 0.46 mm (0.0181 inch). The fuel lubricity test must be performed on a HFRR, operated at 60 °C (140 °F). Refer to "ISO 12156-1 ". Fuels must have minimum viscosity of 1.4 centistokes that is delivered to the fuel injection pump. Fuel cooling may be required in order to maintain minimum viscosity of 1.4 centistokes that is delivered to the fuel injection pump.

## Group 4 Biodiesel

Biodiesel is a fuel that can be defined as mono-alkyl esters of fatty acids. Biodiesel is a fuel that can be made from a variety of feedstock. The most commonly available biodiesel in europe is Rape Methyl Ester (REM). This biodiesel is derived from rapeseed oil. Soy Methyl Ester (SME) is the most common biodiesel in the United States. This biodiesel is derived from soybean oil. Soybean oil or rapeseed oil are the primary feedstocks. These fuels are together known as Fatty Acid Methyl Esters (FAME).

Raw pressed vegetable oils are NOT acceptable for use as a fuel in any concentration in compression engines. Without esterification, these oils gel in the crankcase and the fuel tank. These fuels may not be compatible with many of the elastomers that are used in engines that are manufactured today. In original forms, these oils are not suitable for use as a fuel in compression engines. Alternate base stocks for biodiesel may include animal tallow, waste cooking oils, or a variety of other feedstocks. In order to use any of the products that are listed as fuel, the oil must be esterified.

**Note:** Engines that are manufactured by Perkins are certified by use of the prescribed Environmental Protection Agency (EPA) and European Certification fuels. Perkins does not certify engines on any other fuel. The user of the engine has the responsibility of using the correct fuel that is recommended by the manufacturer and allowed by the EPA and other appropriate regulatory agencies.

### Recommendation for the use of biodiesel

The neat biodiesel must conform to "EN14214" or "ASTM D675" regulations. A maximum of 10% mixture of biodiesel can be used in mineral diesel fuel. The mineral diesel fuel must conform to "EN590", "ASTM D975" or "BS2869 Grade A2" regulations.

In North America, biodiesel and mixtures of biodiesel must be purchased from the BQ9000 authorized manufacturers and BQ9000 certified distributors.

In other areas of the world, the use of biodiesel that is authorized and certified by an appropriate biodiesel quality body is required.

**Note:** When biodiesel, or any blend of biodiesel is used, the user has the responsibility for obtaining the proper local exemptions, regional exemptions, and/or national exemptions that are required for the use of biodiesel in any Perkins engine that is regulated by emissions standards. Biodiesel that meets "EN14214" is acceptable. The biodiesel must be blended with an acceptable distillate diesel fuel at the maximum stated percentages. However, the following operational recommendations must be followed:

- The oil change interval can be affected by the use of biodiesel. Use Services Oil Analysis in order to monitor the condition of the engine oil. Use Services Oil Analysis also in order to determine the oil change interval that is optimum.
- Confirm that biodiesel is acceptable for use with the manufacturer of the fuel filters.
- In a comparison of distillate fuels to biodiesel, biodiesel provides less energy per gallon by 5% to 7%. Do NOT change the engine rating in order to compensate for the power loss. This will help avoid engine problems when the engine is converted back to 100 percent distillate diesel fuel.
- The compatibility of the elastomers with biodiesel is being monitored. The condition of seals and hoses should be monitored regularly.
- Biodiesel may pose low ambient temperature problems for both storage and operation. At low ambient temperatures, fuel may need to be stored in a heated building or a heated storage tank. The fuel system may require heated fuel lines, filters, and tanks. Filters may plug and fuel in the tank may solidify at low ambient temperatures if precautions are not taken. Consult your biodiesel supplier for assistance in the blending and attainment of the proper cloud point for the fuel.
- Biodiesel has poor oxidation stability, which can result in long term problems in the storage of biodiesel. The poor oxidation stability may accelerate fuel oxidation in the fuel system. This is especially true in engines with electronic fuel systems because these engines operate at higher temperatures. Consult the fuel supplier for oxidation stability additives.

- Biodiesel is a fuel that can be made from a variety of feedstock. The feedstock that is used can affect the performance of the product. Two of the characteristics of the fuel that are affected are cold flow and oxidation stability. Contact your fuel supplier for guidance.
- Biodiesel or biodiesel blends are not recommended for engines that will operate occasionally. This is due to poor oxidation stability. If the user is prepared to accept some risk, then limit biodiesel to a maximum of B5. Examples of applications that should limit the use of biodiesel are the following: Standby Generator sets and certain emergency vehicles
- Biodiesel is an excellent medium for microbial contamination and growth. Microbial contamination and growth can cause corrosion in the fuel system and premature plugging of the fuel filter. The use of conventional anti-microbial additives and the effectiveness of conventional anti-microbial additives in biodiesel is not known. Consult your supplier of fuel and additive for assistance.
- Care must be taken in order to remove water from fuel tanks. Water accelerates microbial contamination and growth. When biodiesel is compared to distillate fuels, water is naturally more likely to exist in the biodiesel.

## Fuel for Cold Weather Operation

The European standard "EN590" contains climate dependant requirements and a range of options. The options can be applied differently in each country. There are 5 classes that are given to arctic climates and severe winter climates. 0, 1, 2, 3 and 4.

Fuel that complies with "EN590" CLASS 4 can be used at temperatures as low as  $-44\text{ }^{\circ}\text{C}$  ( $-47.2\text{ }^{\circ}\text{F}$ ). Refer to "EN590" for a detailed discretion of the physical properties of the fuel.

The diesel fuel "ASTM D975 Grade 1-D S15 or S500" that is used in the united states of america may be used in very cold temperatures that are below  $-18\text{ }^{\circ}\text{C}$  ( $-0.4\text{ }^{\circ}\text{F}$ ).

In extreme cold ambient conditions, you may also use fuels that are listed in the table 28 . These fuels are intended to be used in temperatures that can be as low as  $-54\text{ }^{\circ}\text{C}$  ( $-65.2\text{ }^{\circ}\text{F}$ ).

Table 28

Light Distillate Fuels <sup>(1)</sup>	
Specification	Grade
"MIL-DTL-5624U"	JP-5

(continued)

(Table 28, contd)

"MIL-DTL-83133E"	JP-8
"ASTM D1655"	Jet-A-1

<sup>(1)</sup> The use of these fuels is acceptable with an appropriate fuel additive and the fuels must meet minimum requirements that are stated in Tables 24 , 25 and 26 . Fuel samples should be analyzed for the compliance. Fuels MUST NOT exceed 0.46 mm lubricity wear scar diameter that is tested on a HFFR . The test must be performed at  $60\text{ }^{\circ}\text{C}$ . Refer to "ISO 12156-1". Fuels must have minimum viscosity of 1.4 centistokes that is delivered to the fuel injection pump. Fuel cooling may be required in order to maintain minimum viscosity of 1.4 centistokes that is delivered to the fuel injection pump.

## WARNING

**Mixing alcohol or gasoline with diesel fuel can produce an explosive mixture in the engine crankcase or the fuel tank. Alcohol or gasoline must not be used in order to dilute diesel fuel. Failure to follow this instruction may result in death or personal injury.**

There are many other diesel fuel specifications that are published by governments and by technological societies. Usually, those specifications do not review all the requirements that are addressed in tables 24 , 25 and 26 . To ensure optimum engine performance, a complete fuel analysis should be obtained before engine operation. The fuel analysis should include all of the properties that are stated in the tables 24 , 25 and 26 .

## Fuel Additive

Supplemental diesel fuel additives are not generally recommended. This is due to potential damage to the fuel system or the engine. Your fuel supplier or the fuel manufacturer will add the appropriate supplemental diesel fuel additives.

Perkins recognizes the fact that additives may be required in some special circumstances. Fuel additives need to be used with caution. The additive may not be compatible with the fuel. Some additives may precipitate. This action causes deposits in the fuel system. The deposits may cause seizure. Some additives may be corrosive, and some additives may be harmful to the elastomers in the fuel system. Some additives may raise fuel sulfur levels above the maximum that is allowed by the EPA or the other regulatory agencies. Contact your fuel supplier for those circumstances when fuel additives are required. Your fuel supplier can recommend the appropriate fuel additive and the correct level of treatment.

**Note:** For the best results, your fuel supplier should treat the fuel when additives are required. The treated fuel must meet the requirements that are stated in tables 24 , 25 and 26 .

i06791332

## Fluid Recommendations (Coolant Specifications)

### General Coolant Information

---

#### NOTICE

Never add coolant to an overheated engine. Engine damage could result. Allow the engine to cool first.

---



---

#### NOTICE

If the engine is to be stored in, or shipped to an area with below freezing temperatures, the cooling system must be either protected to the lowest outside temperature or drained completely to prevent damage.

---



---

#### NOTICE

Frequently check the specific gravity of the coolant for proper freeze protection or for anti-boil protection.

---

Clean the cooling system for the following reasons:

- Contamination of the cooling system
  - Overheating of the engine
  - Foaming of the coolant
- 

---

#### NOTICE

Never operate an engine without water temperature regulators in the cooling system. Water temperature regulators help to maintain the engine coolant at the proper operating temperature. Cooling system problems can develop without water temperature regulators.

---

Many engine failures are related to the cooling system. The following problems are related to cooling system failures: Overheating, leakage of the water pump and plugged radiators or heat exchangers.

These failures can be avoided with correct cooling system maintenance. Cooling system maintenance is as important as maintenance of the fuel system and the lubrication system. Quality of the coolant is as important as the quality of the fuel and the lubricating oil.

Coolant is normally composed of three elements: Water, additives, and glycol.

## Water

Water is used in the cooling system to transfer heat.

**Distilled water or deionized water is recommended for use in engine cooling systems.**

DO NOT use the following types of water in cooling systems: Hard water, softened water that has been conditioned with salt and sea water.

If distilled water or deionized water is not available, use water with the properties that are listed in Table 29 .

Table 29

Acceptable Water	
Property	Maximum Limit
Chloride (Cl)	40 mg/L
Sulfate (SO <sub>4</sub> )	100 mg/L
Total Hardness	170 mg/L
Total Solids	340 mg/L
Acidity	pH of 5.5 to 9.0

For a water analysis, consult one of the following sources:

- Local water utility company
- Agricultural agent
- Independent laboratory

## Additives

Additives help to protect the metal surfaces of the cooling system. A lack of coolant additives or insufficient amounts of additives enable the following conditions to occur:

- Corrosion
- Formation of mineral deposits
- Rust
- Scale
- Foaming of the coolant

Many additives are depleted during engine operation. These additives must be replaced periodically.

Additives must be added at the correct concentration. Over concentration of additives can cause the inhibitors to drop out-of-solution. The deposits can enable the following problems to occur:

- Formation of gel compounds
- Reduction of heat transfer

Maintenance Section  
Coolant Specifications

- Leakage of the water pump seal
- Plugging of radiators, coolers, and small passages

**Glycol**

Glycol in the coolant helps to provide protection against the following conditions:

- Boiling
- Freezing
- Cavitation of the water pump

For optimum performance, Perkins recommends a 1:1 mixture of a water/glycol solution.

**Note:** Use a mixture that will provide protection against the lowest ambient temperature.

**Note:** 100 percent pure glycol will freeze at a temperature of -13 °C (8.6 °F).

Most conventional antifreezes use ethylene glycol. Propylene glycol may also be used. In a 1:1 mixture with water, ethylene and propylene glycol provide similar protection against freezing and boiling. Refer to Table 30 and refer to table 31 .

Table 30

Ethylene Glycol	
Concentration	Freeze Protection
50 Percent	-36 °C (-33 °F)
60 Percent	-51 °C (-60 °F)

**NOTICE**

Do not use propylene glycol in concentrations that exceed 50 percent glycol because of the reduced heat transfer capability of propylene glycol. Use ethylene glycol in conditions that require additional protection against boiling or freezing.

Table 31

Propylene Glycol	
Concentration	Freeze Protection
50 Percent	-29 °C (-20 °F)

To check the concentration of glycol in the coolant, measure the specific gravity of the coolant.

**Coolant Recommendations**

- ELC\_\_\_\_\_Extended Life Coolant
- SCA\_\_\_\_\_Supplement Coolant Additive
- ASTM\_\_\_\_\_American Society for Testing and Materials

The following two coolants are used in Perkins diesel engines:

**Preferred** – Perkins ELC

**Acceptable** – A commercial heavy-duty antifreeze that meets “ASTM D6210” specifications

**NOTICE**

**The Perkins industrial engines must be operated with a 1:1 mixture of water and glycol.**

**NOTICE**

Do not use a commercial coolant/antifreeze that only meets the ASTM D3306 specification. This type of coolant/antifreeze is made for light automotive applications.

Perkins recommends a 1:1 mixture of water and glycol. This mixture of water and glycol will provide optimum heavy-duty performance as an antifreeze. This ratio may be increased to 1:2 water to glycol if extra freezing protection is required.

Table 32

Coolant Service Life	
Coolant Type	Service Life <sup>(1)</sup>
Perkins ELC	6,000 Service Hours or Three Years
Commercial Heavy-Duty Anti-freeze that meets “ASTM D6210”	3000 Service Hours or Two Year
Commercial SCA inhibitor and Water	3000 Service Hours or One Year

<sup>(1)</sup> Use the interval that occurs first. The cooling system must also be flushed out at this time.

**ELC**

Perkins provides ELC for use in the following applications:

- Heavy-duty spark ignited gas engines
- Heavy-duty diesel engines
- Automotive applications

The anti-corrosion package for ELC is different from the anti-corrosion package for other coolants. ELC is an ethylene glycol base coolant. However, ELC contains organic corrosion inhibitors and antifoam agents with low amounts of nitrite. Perkins ELC has been formulated with the correct amount of these additives to provide superior corrosion protection for all metals in engine cooling systems.

ELC is available in a premixed cooling solution with distilled water. ELC is a 1:1 mixture. The Premixed ELC provides freeze protection to  $-36\text{ }^{\circ}\text{C}$  ( $-33\text{ }^{\circ}\text{F}$ ). The Premixed ELC is recommended for the initial fill of the cooling system. The Premixed ELC is also recommended for topping off the cooling system.

Containers of several sizes are available. Consult your Perkins distributor for the part numbers.

## ELC Cooling System Maintenance

### Correct additions to the Extended Life Coolant

---

#### NOTICE

Use only Perkins products for pre-mixed or concentrated coolants.

Mixing Extended Life Coolant with other products reduces the Extended Life Coolant service life. Failure to follow the recommendations can reduce cooling system components life unless appropriate corrective action is performed.

To maintain the correct balance between the antifreeze and the additives, you must maintain the recommended concentration of ELC. Lowering the proportion of antifreeze lowers the proportion of additive. Lowering the ability of the coolant to protect the system will form pitting, from cavitation, from erosion, and from deposits.

---

#### NOTICE

Do not use a conventional coolant to top-off a cooling system that is filled with Extended Life Coolant (ELC).

Do not use standard supplemental coolant additive (SCA).

When using Perkins ELC, do not use standard SCA's or SCA filters.

### ELC Cooling System Cleaning

**Note:** If the cooling system is already using ELC, cleaning agents are not required to be used at the specified coolant change interval. Cleaning agents are only required if the system has been contaminated by the addition of some other type of coolant or by cooling system damage.

Clean water is the only cleaning agent that is required when ELC is drained from the cooling system.

Before the cooling system is filled, the heater control (if equipped) must be set to the HOT position. Refer to the OEM to set the heater control. After the cooling system is drained and the cooling system is refilled, operate the engine until the coolant level reaches the normal operating temperature and until the coolant level stabilizes. As needed, add the coolant mixture to fill the system to the specified level.

### Changing to Perkins ELC

To change from heavy-duty antifreeze to the Perkins ELC, perform the following steps:

---

#### NOTICE

Care must be taken to ensure that all fluids are contained during performance of inspection, maintenance, testing, adjusting and the repair of the product. Be prepared to collect the fluid with suitable containers before opening any compartment or disassembling any component containing fluids.

Dispose of all fluids according to local regulations and mandates.

- 
1. Drain the coolant into a suitable container.
  2. Dispose of the coolant according to local regulations.
  3. Fill the cooling system with a 33 percent solution of Perkins ELC and operate the engine, ensure that the thermostat opens. Stop the engine and allow the engine to cool. Drain the coolant.
- Note:** Use distilled or deionized water in the solution.
4. Again, fill the cooling system with a 33 percent solution of Perkins ELC and operate the engine ensure that the thermostat opens. Stop the engine and allow to cool.
  5. Drain the cooling system.

---

#### NOTICE

Incorrect or incomplete flushing of the cooling system can result in damage to copper and other metal components.

- 
6. Fill the cooling system with the Perkins Premixed ELC. Operate the engine. Ensure that all coolant valves open then stop the engine. When cool check the coolant level.

## ELC Cooling System Contamination

### NOTICE

Mixing ELC with other products reduces the effectiveness of the ELC and shortens the ELC service life. Use only Perkins Products for premixed or concentrate coolants. Failure to follow these recommendations can result in shortened cooling system component life.

ELC cooling systems can withstand contamination to a maximum of 10 percent of conventional heavy-duty antifreeze or SCA. If the contamination exceeds 10 percent of the total system capacity, perform ONE of the following procedures:

- Drain the cooling system into a suitable container. Dispose of the coolant according to local regulations. Flush the system with a 5 to 10 percent solution of Perkins ELC. Fill the system with the Perkins ELC.
- Drain a portion of the cooling system into a suitable container according to local regulations. Then, fill the cooling system with premixed ELC. This procedure should lower the contamination to less than 10 percent.
- Maintain the system as a conventional Heavy-Duty Coolant. Treat the system with an SCA. Change the coolant at the interval that is recommended for the conventional Heavy-Duty Coolant.

## Commercial Heavy-Duty Antifreeze and SCA

### NOTICE

Commercial Heavy-Duty Coolant which contains Amine as part of the corrosion protection system must not be used.

### NOTICE

Never operate an engine without water temperature regulators in the cooling system. Water temperature regulators help to maintain the engine coolant at the correct operating temperature. Cooling system problems can develop without water temperature regulators.

Check the antifreeze (glycol concentration) to ensure adequate protection against boiling or freezing. Perkins recommends the use of a refractometer for checking the glycol concentration. A hydrometer should not be used.

Perkins engine cooling systems should be tested at 500-hour intervals for the concentration of SCA.

Additions of SCA are based on the results of the test. An SCA that is liquid may be needed at 500-hour intervals.

## Adding the SCA to Heavy-Duty Coolant at the Initial Fill

Use the equation that is in Table 33 to determine the amount of SCA that is required when the cooling system is initially filled.

Table 33

Equation For Adding The SCA To The Heavy-Duty Coolant At The Initial Fill
$V \times 0.07 = X$
V is the total volume of the cooling system.
X is the amount of SCA that is required.

Table 34 is an example for using the equation that is in Table 33 .

Table 34

Example Of The Equation For Adding The SCA To The Heavy-Duty Coolant At The Initial Fill		
Total Volume of the Cooling System (V)	Multiplication Factor	Amount of SCA that is Required (X)
15 L (4 US gal)	× 0.07	1.05 L (35.5 oz)

## Adding The SCA to The Heavy-Duty Coolant For Maintenance

Heavy-duty antifreeze of all types REQUIRE periodic additions of an SCA.

Test the antifreeze periodically for the concentration of SCA. For the interval, refer to the Operation and Maintenance Manual, "Maintenance Interval Schedule" (Maintenance Section). Cooling System Supplemental Coolant Additive (SCA) Test/Add.

Additions of SCA are based on the results of the test. The size of the cooling system determines the amount of SCA that is needed.

Use the equation that is in Table 35 to determine the amount of SCA that is required, if necessary:

Table 35

Equation For Adding The SCA To The Heavy-Duty Coolant For Maintenance
$V \times 0.023 = X$
V is the total volume of the cooling system.
X is the amount of SCA that is required.

Table 36 is an example for using the equation that is in Table 35 .

Table 36

Example Of The Equation For Adding The SCA To The Heavy-Duty Coolant For Maintenance		
Total Volume of the Cooling System (V)	Multiplication Factor	Amount of SCA that is Required (X)
15 L (4 US gal)	× 0.023	0.35 L (11.7 oz)

### Cleaning the System of Heavy-Duty Antifreeze

- Clean the cooling system after used coolant is drained or before the cooling system is filled with new coolant.
- Clean the cooling system whenever the coolant is contaminated or whenever the coolant is foaming.

i06791749

## Fluid Recommendations

### General Lubricant Information

Because of government regulations regarding the certification of exhaust emissions from the engine, the lubricant recommendations must be followed.

#### API Oils

The Engine Oil Licensing and Certification System by the American Petroleum Institute (API) is recognized by Perkins. For detailed information about this system, see the latest edition of the “API publication No. 1509”. Engine oils that bear the API symbol are authorized by API.

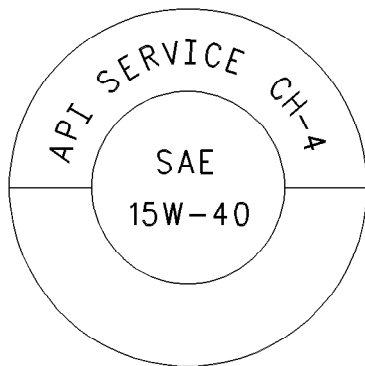

Illustration 34

g00546535

Typical API symbol

Table 37

API Classifications for the Industrial Engine
Oil Specification
CH-4 minimum specification CI-4

### Terminology

Certain abbreviations follow the nomenclature of “SAE J754”. Some classifications follow “SAE J183” abbreviations. In addition to Perkins definitions, there are other definitions that will be of assistance in purchasing lubricants. Recommended oil viscosities can be found in this publication, “Fluid Recommendations/Engine Oil” topic (Maintenance Section).

## Engine Oil

### Commercial Oils

The performance of commercial diesel engine oils is based on American Petroleum Institute (API) classifications. These API classifications are developed to provide commercial lubricants for a broad range of diesel engines that operate at various conditions.

Only use commercial oils that meet the following classifications:

- API CH-4 minimum multigrade oil
- API CI-4
- ACEAE3

To make the correct choice of a commercial oil, refer to the following explanations:

**API CH-4** – API CH-4 oils were developed to meet the requirements of the new high-performance diesel engines. Also, the oil was designed to meet the requirements of the low emissions diesel engines. API CH-4 oils are also acceptable for use in older diesel engines and in diesel engines that use high sulfur diesel fuel.

Three new engine tests were developed for the API CH-4 oil. The first test specifically evaluates deposits on pistons for engines with the two-piece steel piston. This test (piston deposit) also measures the control of oil consumption. A second test is conducted with moderate oil soot. The second test measures the following criteria: wear of piston rings, wear of cylinder liners and resistance to corrosion. A third new test measures the following characteristics with high levels of soot in the oil: wear of the valve train, resistance of the oil in plugging the oil filter and control of sludge.

In addition to the new tests, API CH-4 oils have tougher limits for viscosity control in applications that generate high soot. The oils also have improved oxidation resistance. API CH-4 oils must pass an additional test (piston deposit) for engines that use aluminum pistons (single piece). Oil performance is also established for engines that operate in areas with high sulfur diesel fuel.

All these improvements allow the API CH-4 oil to achieve optimum oil change intervals. API CH-4 oils are recommended for use in extended oil change intervals. API CH-4 oils are recommended for conditions that demand a premium oil. Your Perkins distributor has specific guidelines for optimizing oil change intervals.

Some commercial oils that meet the API classifications may require reduced oil change intervals. To determine the oil change interval, closely monitor the condition of the oil and perform a wear metal analysis.

An oil specification that is above CH-4 is acceptable for use in Perkins engines.

**NOTICE**

Failure to follow these oil recommendations can cause shortened engine service life due to deposits and/or excessive wear.

**Total Base Number (TBN) and Fuel Sulfur Levels for Diesel Engines**

The Total Base Number (TBN) for an oil depends on the fuel sulfur level. For engines that use distillate fuel, the minimum TBN of the new oil must be 10 times the fuel sulfur level. The TBN is defined by "ASTM D2896". The minimum TBN of the oil is 5 regardless of fuel sulfur level. Illustration 35 demonstrates the TBN.

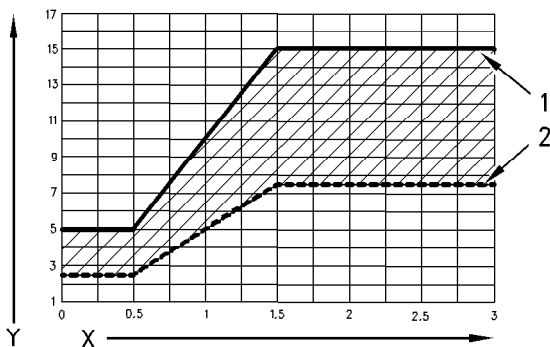

Illustration 35

g00799818

- (Y) TBN by "ASTM D2896"
- (X) Percentage of fuel sulfur by weight
- (1) TBN of new oil
- (2) Change the oil when the TBN deteriorates to 50 percent of the original TBN.

Use the following guidelines for fuel sulfur levels that exceed 1.5 percent:

- Choose an oil with the highest TBN that meets one of these classifications: API CH-4 and API CI-4.
- Reduce the oil change interval. Base the oil change interval on the oil analysis. Ensure that the oil analysis includes the condition of the oil and a wear metal analysis.

Excessive piston deposits can be produced by an oil with a high TBN. These deposits can lead to a loss of control of the oil consumption and to the polishing of the cylinder bore.

**NOTICE**

Operating diesel engines with fuel sulphur levels over 0.5 percent will require shortened oil change intervals in order to help maintain adequate wear protection.

Table 38

Percentage of Sulfur in the fuel	Oil change interval
Lower than 0.5	Normal
0.5 to 1.0	0.75 of normal
Greater than 1.0	0.50 of normal

**Lubricant Viscosity Recommendations for Direct Injection (DI) Diesel Engines**

The correct SAE viscosity grade of oil is determined by the minimum ambient temperature during cold engine start-up, and the maximum ambient temperature during engine operation.

Refer to illustration36 (minimum temperature) to determine the required oil viscosity for starting a cold engine.

Refer to illustration 36 (maximum temperature) to select the oil viscosity for engine operation at the highest ambient temperature that is anticipated.

Generally, use the highest oil viscosity that is available to meet the requirement for the temperature at start-up.



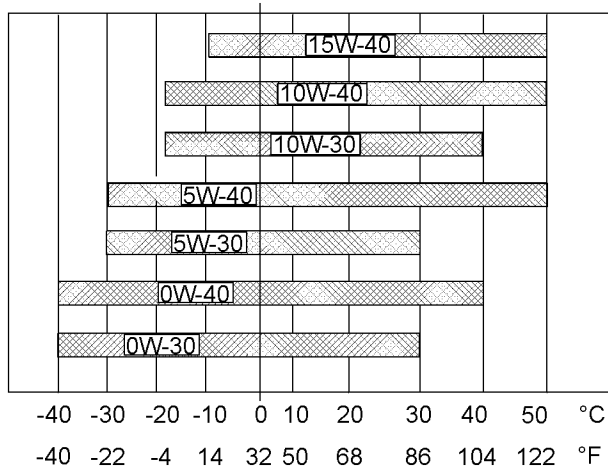

Illustration 36

g03329687

## Synthetic Base Stock Oils

Synthetic base oils are acceptable for use in these engines if these oils meet the performance requirements that are specified for the engine.

Synthetic base oils generally perform better than conventional oils in the following two areas:

- Synthetic base oils have improved flow at low temperatures especially in arctic conditions.
- Synthetic base oils have improved oxidation stability especially at high operating temperatures.

Some synthetic base oils have performance characteristics that enhance the service life of the oil. Perkins does not recommend the automatic extending of the oil change intervals for any type of oil.

## Re-refined Base Stock Oils

Re-refined base stock oils are acceptable for use in Perkins engines if these oils meet the performance requirements that are specified by Perkins. Re-refined base stock oils can be used exclusively in finished oil or in a combination with new base stock oils. The US military specifications and the specifications of other heavy equipment manufacturers also allow the use of re-refined base stock oils that meet the same criteria.

The process that is used to make re-refined base stock oil should adequately remove all wear metals that are in the used oil and all the additives that are in the used oil. The process that is used to make re-refined base stock oil generally involves the process of vacuum distillation and hydrotreating the used oil. Filtering is adequate for the production of high quality, re-refined base stock oil.

## Lubricants for Cold Weather

When an engine is started and an engine is operated in ambient temperatures below  $-20^{\circ}\text{C}$  ( $-4^{\circ}\text{F}$ ), use multigrade oils that are capable of flowing in low temperatures.

These oils have lubricant viscosity grades of SAE 0W or SAE 5W.

When an engine is started and operated in ambient temperatures below  $-30^{\circ}\text{C}$  ( $-22^{\circ}\text{F}$ ), use a synthetic base stock multigrade oil with an 0W viscosity grade or with a 5W viscosity grade. Use an oil with a pour point that is lower than  $-50^{\circ}\text{C}$  ( $-58^{\circ}\text{F}$ ).

The number of acceptable lubricants is limited in cold-weather conditions. Perkins recommends the following lubricants for use in cold-weather conditions:

**First Choice** – Use oil with an EMA DHD-1 Recommended Guideline. Use a CH-4 oil that has an API license. The oil should be either SAE 0W20, SAE 0W30, SAE 0W40, SAE 5W30, or SAE 5W40 lubricant viscosity grade.

**Second Choice** – Use an oil that has a CH-4 additive package. Although the oil has not been tested for the requirements of the API license, the oil must be either SAE 0W20, SAE 0W30, SAE 0W40, SAE 5W30, or SAE 5W40.

### NOTICE

Shortened engine service life could result if second choice oils are used.

## Aftermarket Oil Additives

Perkins does not recommend the use of aftermarket additives in oil. It is not necessary to use aftermarket additives to achieve the engines maximum service life or rated performance. Fully formulated, finished oils consist of base oils and of commercial additive packages. These additive packages are blended into the base oils at precise percentages to help provide finished oils with performance characteristics that meet industry standards.

There are no industry standard tests that evaluate the performance or the compatibility of aftermarket additives in finished oil. Aftermarket additives may not be compatible with the finished oils additive package, which could lower the performance of the finished oil. The aftermarket additive could fail to mix with the finished oil. This action could produce sludge in the crankcase. Perkins discourages the use of aftermarket additives in finished oils.

To achieve the best performance from a Perkins engine, conform to the following guidelines:

- Select the correct oil, or a commercial oil that meets the “EMA Recommended Guideline on Diesel Engine Oil” or the recommended API classification.
- See the appropriate “Lubricant Viscosities” table to find the correct oil viscosity grade for your engine.
- At the specified interval, service the engine. Use new oil and install a new oil filter.
- Perform maintenance at the intervals that are specified in the Operation and Maintenance Manual, “Maintenance Interval Schedule”.

## Oil analysis

Some engines may be equipped with an oil sampling valve. If oil analysis is required, the oil sampling valve is used to obtain samples of the engine oil. The oil analysis will complement the preventive maintenance program.

The oil analysis is a diagnostic tool that is used to determine oil performance and component wear rates. Contamination can be identified and measured by using the oil analysis. The oil analysis includes the following tests:

- The Wear Rate Analysis monitors the wear of the engines metals. The amount of wear metal and type of wear metal that is in the oil is analyzed. The increase in the rate of engine wear metal in the oil is as important as the quantity of engine wear metal in the oil.
- Tests are conducted to detect contamination of the oil by water, glycol, or fuel.
- The Oil Condition Analysis determines the loss of the oils lubricating properties. An infrared analysis is used to compare the properties of new oil to the properties of the used oil sample. This analysis allows technicians to determine the amount of deterioration of the oil during use. This analysis also allows technicians to verify the performance of the oil according to the specification during the entire oil change interval.

# Maintenance Recommendations

i03751181

## System Pressure Release

### Coolant System

#### WARNING

**Pressurized system: Hot coolant can cause serious burn. To open cap, stop engine, wait until radiator is cool. Then loosen cap slowly to relieve the pressure.**

To relieve the pressure from the coolant system, turn off the engine. Allow the cooling system pressure cap to cool. Remove the cooling system pressure cap slowly in order to relieve pressure.

### Fuel System

To relieve the pressure from the fuel system, turn off the engine.

#### High Pressure Fuel Lines (If Equipped)

#### WARNING

**Contact with high pressure fuel may cause fluid penetration and burn hazards. High pressure fuel spray may cause a fire hazard. Failure to follow these inspection, maintenance and service instructions may cause personal injury or death.**

The high pressure fuel lines are the fuel lines that are between the high pressure fuel pump and the high pressure fuel manifold and the fuel lines that are between the fuel manifold and cylinder head. These fuel lines are different from fuel lines on other fuel systems.

This is because of the following differences:

- The high pressure fuel lines are constantly charged with high pressure.
- The internal pressures of the high pressure fuel lines are higher than other types of fuel system.

Before any service or repair is performed on the engine fuel lines, perform the following tasks:

1. Stop the engine.
2. Wait for ten minutes.

Do not loosen the high pressure fuel lines in order to remove air pressure from the fuel system.

### Engine Oil

To relieve pressure from the lubricating system, turn off the engine.

i03751203

## Welding on Engines with Electronic Controls

#### NOTICE

Because the strength of the frame may decrease, some manufacturers do not recommend welding onto a chassis frame or rail. Consult the OEM of the equipment or your Perkins dealer regarding welding on a chassis frame or rail.

Correct welding procedures are necessary in order to avoid damage to the engine's ECM, sensors, and associated components. When possible, remove the component from the unit and then weld the component. If removal of the component is not possible, the following procedure must be followed when you weld on a unit that is equipped with a Perkins Electronic Engine. The following procedure is considered to be the safest procedure to weld on a component. This procedure should provide a minimum risk of damage to electronic components.

#### NOTICE

Do not ground the welder to electrical components such as the ECM or sensors. Improper grounding can cause damage to the drive train, the bearings, hydraulic components, electrical components, and other components.

Do not ground the welder across the centerline of the package. Improper grounding could cause damage to the bearings, the crankshaft, the rotor shaft, and other components.

Clamp the ground cable from the welder to the component that will be welded. Place the clamp as close as possible to the weld. This will help reduce the possibility of damage.

**Note:** Perform the welding in areas that are free from explosive hazards.

1. Stop the engine. Turn the switched power to the OFF position.
2. Disconnect the negative battery cable from the battery. If a battery disconnect switch is provided, open the switch.

Maintenance Section  
Welding on Engines with Electronic Controls

3. Disconnect the J1/P1 and J2/P2 connectors from the ECM. Move the harness to a position that will not allow the harness to accidentally move back and make contact with any of the ECM pins.

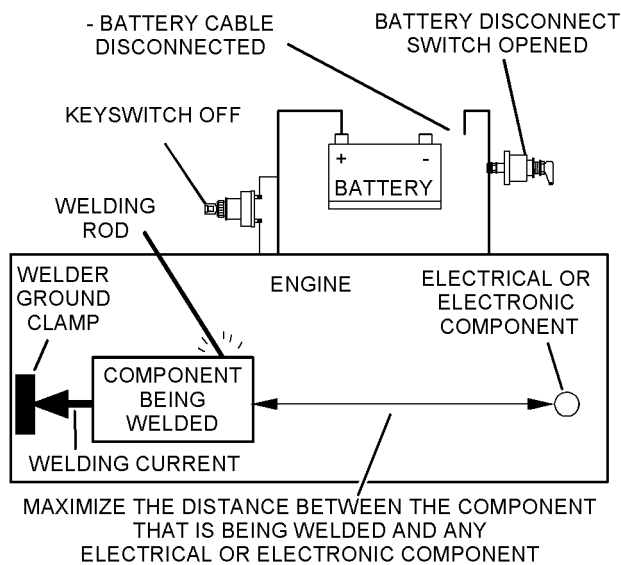

Illustration 37

g01143634

4. Connect the welding ground cable directly to the part that will be welded. Place the ground cable as close as possible to the weld in order to reduce the possibility of welding current damage to bearings, hydraulic components, electrical components, and ground straps.

**Note:** If electrical/electronic components are used as a ground for the welder, or electrical/electronic components are located between the welder ground and the weld, current flow from the welder could severely damage the component.

5. Protect the wiring harness from welding debris and spatter.
6. Use standard welding practices to weld the materials.

i08156304

## Maintenance Interval Schedule

### When Required

“ Battery - Replace“	65
“Battery or Battery Cable - Disconnect“	
“ Engine - Clean“	73
“ Engine Air Cleaner Element - Replace“	73
“ Fuel System - Prime“	80
“ Severe Service Application - Check“	92

### Daily

“ Cooling System Coolant Level - Check“	70
“ Driven Equipment - Check“	72
“ Engine Air Cleaner Service Indicator - Inspect“	74
“ Engine Air Precleaner - Check/Clean“	75
“ Engine Oil Level - Check“	76
“ Fuel System Primary Filter/Water Separator - Drain“	89
“ Walk-Around Inspection“	93

### Every 50 Service Hours or Weekly

“ Fuel Tank Water and Sediment - Drain“	90
---	----

### Every 250 Service Hours or 6 Months

“ Alternator and Fan Belts - Inspect/Adjust“	63
--	----

### Every 500 Service Hours or 1 Year

“ Battery Electrolyte Level - Check“	65
“ Cooling System Supplemental Coolant Additive (SCA) - Test/Add“	71
“ Engine Air Cleaner Element - Replace“	73
“ Engine Oil and Filter - Change“	76
“ Fuel System Filter - Replace“	85
“ Fuel System Primary Filter - Replace“	88
“ Hoses and Clamps - Inspect/Replace“	90

“ Radiator - Clean“	
---------------------	--

### Every 1000 Service Hours

“ Alternator and Fan Belts - Replace“	64
“ Engine Valve Lash - Inspect/Adjust“	79
“ Turbocharger - Inspect“	93

### Every 2000 Service Hours

“ Aftercooler Core - Inspect“	62
“ Alternator - Inspect“	63
“ Engine Crankcase Breather - Replace“	75
“ Engine Mounts - Inspect“	76
“ Starting Motor - Inspect“	92

### Every 3000 Service Hours

“ Cooling System Water Temperature Regulator - Replace“	72
“ Fuel Injector - Test/Change“	79
“ Water Pump - Inspect“	94

### Every 3000 Service Hours or 2 Years

“ Cooling System Coolant (Commercial Heavy-Duty) - Change“	66
--	----

### Every 4000 Service Hours

“ Aftercooler Core - Clean/Test“	62
----------------------------------	----

### Every 6000 Service Hours or 3 Years

“ Cooling System Coolant (ELC) - Change“	68
--	----

i03632383

## Aftercooler Core - Clean/Test (Air-To-Air Aftercooler)

1. Remove the core. Refer to the OEM information for the correct procedure.
2. Turn the aftercooler core upside-down in order to remove debris.

### **WARNING**

**Personal injury can result from air pressure.**

**Personal injury can result without following proper procedure. When using pressure air, wear a protective face shield and protective clothing.**

**Maximum air pressure at the nozzle must be less than 205 kPa (30 psi) for cleaning purposes.**

3. Pressurized air is the preferred method for removing loose debris. Direct the air in the opposite direction of the fan's air flow. Hold the nozzle approximately 6 mm (.25 inch) away from the fins. Slowly move the air nozzle in a direction that is parallel with the tubes. This will remove debris that is between the tubes.
4. Pressurized water may also be used for cleaning. The maximum water pressure for cleaning purposes must be less than 275 kPa (40 psi). Use pressurized water in order to soften mud. Clean the core from both sides.

### NOTICE

Do not use a high concentration of caustic cleaner to clean the core. A high concentration of caustic cleaner can attack the internal metals of the core and cause leakage. Only use the recommended concentration of cleaner.

5. Back flush the core with a suitable cleaner.
6. Steam clean the core in order to remove any residue. Flush the fins of the aftercooler core. Remove any other trapped debris.
7. Wash the core with hot, soapy water. Rinse the core thoroughly with clean water.
8. Dry the core with compressed air. Direct the air in the reverse direction of the normal flow.
9. Inspect the core in order to ensure cleanliness. Pressure test the core. If necessary, repair the core.

10. Install the core. Refer to the OEM information for the correct procedure.
11. After cleaning, start the engine and accelerate the engine to high idle rpm. This will help in the removal of debris and drying of the core. Stop the engine. Use a light bulb behind the core in order to inspect the core for cleanliness. Repeat the cleaning, if necessary.

i03632416

## Aftercooler Core - Inspect

**Note:** Adjust the frequency of cleaning according to the effects of the operating environment.

Inspect the aftercooler for these items: damaged fins, corrosion, dirt, grease, insects, leaves, oil and other debris. Clean the aftercooler, if necessary.

For air-to-air aftercoolers, use the same methods that are used for cleaning radiators.

### **WARNING**

**Personal injury can result from air pressure.**

**Personal injury can result without following proper procedure. When using pressure air, wear a protective face shield and protective clothing.**

**Maximum air pressure at the nozzle must be less than 205 kPa (30 psi) for cleaning purposes.**

After cleaning, start the engine and accelerate the engine to high idle rpm. This will help in the removal of debris and drying of the core. Stop the engine. Use a light bulb behind the core in order to inspect the core for cleanliness. Repeat the cleaning, if necessary.

Inspect the fins for damage. Bent fins may be opened with a "comb".

**Note:** If parts of the aftercooler system are repaired or replaced, a leak test is highly recommended.

Inspect these items for good condition: Welds, mounting brackets, air lines, connections, clamps and seals. Make repairs, if necessary.

i02322311

## Alternator - Inspect

Perkins recommends a scheduled inspection of the alternator. Inspect the alternator for loose connections and correct battery charging. Check the ammeter (if equipped) during engine operation in order to ensure correct battery performance and/or correct performance of the electrical system. Make repairs, as required.

Check the alternator and the battery charger for correct operation. If the batteries are correctly charged, the ammeter reading should be very near zero. All batteries should be kept charged. The batteries should be kept warm because temperature affects the cranking power. If the battery is too cold, the battery will not crank the engine. When the engine is not run for long periods of time or if the engine is run for short periods, the batteries may not fully charge. A battery with a low charge will freeze more easily than a battery with a full charge.

i02665597

## Alternator and Fan Belts - Inspect/Adjust

### Inspection

To maximize the engine performance, inspect the belts for wear and for cracking. Replace belts that are worn or damaged.

For applications that require multiple drive belts, replace the belts in matched sets. Replacing only one belt of a matched set will cause the new belt to carry more load because the older belt is stretched. The additional load on the new belt could cause the new belt to break.

If the belts are too loose, vibration causes unnecessary wear on the belts and pulleys. Loose belts may slip enough to cause overheating.

To accurately check the belt tension, a suitable gauge should be used.

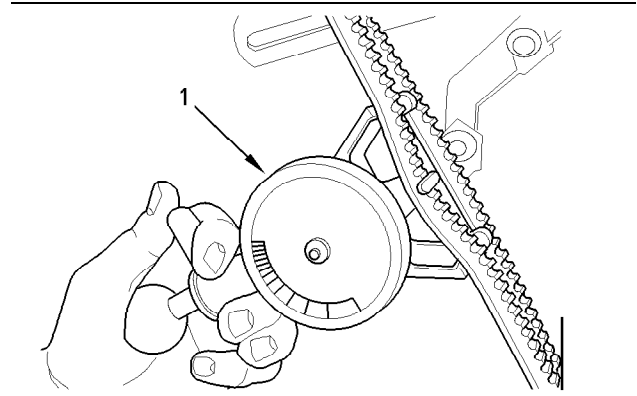

Illustration 38

g01003936

### Typical example

(1) Burroughs Gauge

Install the gauge (1) at the center of the belt between the alternator and the crankshaft pulley and check the belt tension. The correct tension for a new belt is 400 N (90 lb) to 489 N (110 lb). The correct tension for a used belt that has been in operation for 30 minutes or more at the rated speed is 267 N (60 lb) to 356 N (80 lb).

If twin belts are installed, check and adjust the tension on both belts.

### Adjustment

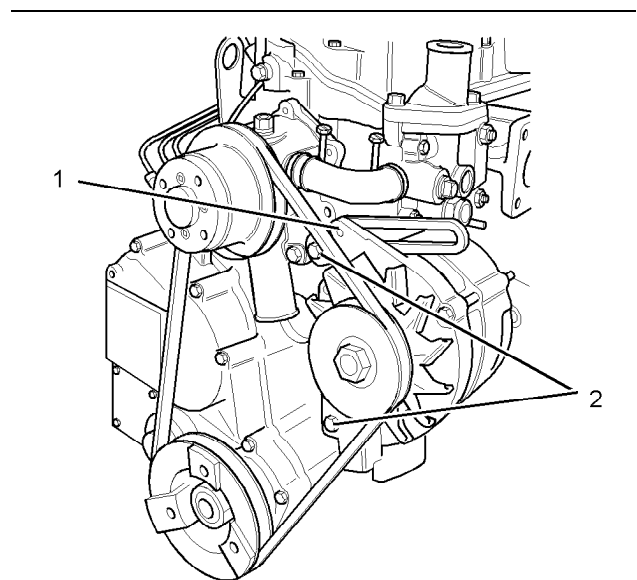

Illustration 39

g01091158

### Typical example

(1) Adjusting bolt  
(2) Mounting bolts

1. Loosen mounting bolts (2) and adjusting bolt (1).

2. Move the alternator in order to increase or decrease the belt tension.
3. Tighten adjusting bolt (1). Tighten mounting bolts (2). Refer to the Specifications Manual for the correct torque settings.

i08094157

## Alternator and Fan Belts - Replace

### Removal Procedure

#### NOTICE

Keep all parts clean from contaminants.

Contaminants may cause rapid wear and shortened component life.

1. If the engine is equipped with fan guards, remove the fan guards. Refer to the Original Equipment Manufacturer (OEM) for the correct removal procedure

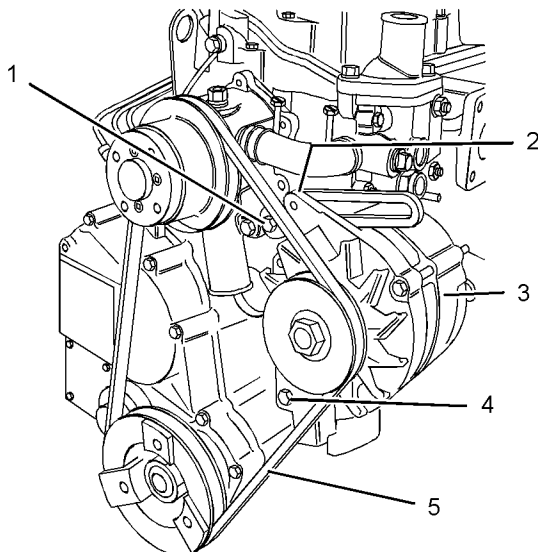

Illustration 40

g01325726

Typical example

2. Loosen bolt (1), bolt (2), and bolt (4).

3. Push alternator (3) toward the engine and remove V-belt (5) from the pulleys.

### Installation Procedure

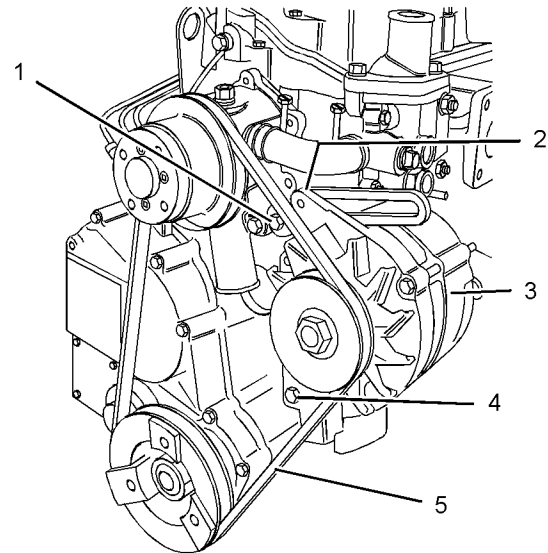

Illustration 41

g01325726

Typical example

1. Install V-belt (5) in position on the pulleys. Refer to illustration 40 for the correct belt routing.
2. Slide alternator (3) away from the engine. Refer to this Operation and Maintenance Manual, "Alternator and Fan Belts - Inspect/Adjust" for information on the correct belt tension. Tighten bolt (1), bolt (2), and (4) to a torque of 25 N·m (18 lb ft).
3. When new belts are installed, check the belt tension again after 20 hours of engine operation.

For applications that require multiple drive belts, replace the belts in matched sets. Replacing only one belt of a matched set will cause the new belt to carry more load because the older belt is stretched. The additional load on the new belt could cause the new belt to break.



- If the engine is equipped with fan guards, install the fan guards. Refer to the OEM for the correct installation procedure

i02322315

## Battery - Replace

### WARNING

Batteries give off combustible gases which can explode. A spark can cause the combustible gases to ignite. This can result in severe personal injury or death.

Ensure proper ventilation for batteries that are in an enclosure. Follow the proper procedures in order to help prevent electrical arcs and/or sparks near batteries. Do not smoke when batteries are serviced.

### WARNING

The battery cables or the batteries should not be removed with the battery cover in place. The battery cover should be removed before any servicing is attempted.

Removing the battery cables or the batteries with the cover in place may cause a battery explosion resulting in personal injury.

- Switch the engine to the OFF position. Remove all electrical loads.
- Turn off any battery chargers. Disconnect any battery chargers.
- The NEGATIVE “-” cable connects the NEGATIVE “-” battery terminal to the NEGATIVE “-” terminal on the starting motor. Disconnect the cable from the NEGATIVE “-” battery terminal.
- The POSITIVE “+” cable connects the POSITIVE “+” battery terminal to the POSITIVE “+” terminal on the starting motor. Disconnect the cable from the POSITIVE “+” battery terminal.

**Note:** Always recycle a battery. Never discard a battery. Dispose of used batteries to an appropriate recycling facility.

- Remove the used battery.
- Install the new battery.

**Note:** Before the cables are connected, ensure that the engine start switch is OFF.

- Connect the cable from the starting motor to the POSITIVE “+” battery terminal.
- Connect the NEGATIVE “-” cable to the NEGATIVE “-” battery terminal.

i02747977

## Battery Electrolyte Level - Check

When the engine is not run for long periods of time or when the engine is run for short periods, the batteries may not fully recharge. Ensure a full charge in order to help prevent the battery from freezing. If batteries are correctly charged, the ammeter reading should be very near zero, when the engine is in operation.

### WARNING

All lead-acid batteries contain sulfuric acid which can burn the skin and clothing. Always wear a face shield and protective clothing when working on or near batteries.

- Remove the filler caps. Maintain the electrolyte level to the “FULL” mark on the battery.  
If the addition of water is necessary, use distilled water. If distilled water is not available use clean water that is low in minerals. Do not use artificially softened water.
- Check the condition of the electrolyte with a suitable battery tester.
- Install the caps.
- Keep the batteries clean.  
Clean the battery case with one of the following cleaning solutions:
  - Use a solution of 0.1 kg (0.2 lb) baking soda and 1 L (1 qt) of clean water.
  - Use a solution of ammonium hydroxide.

Thoroughly rinse the battery case with clean water.

i09570426

i08056195

## Battery or Battery Cable - Disconnect

### WARNING

The battery cables or the batteries should not be removed with the battery cover in place. The battery cover should be removed before any servicing is attempted.

Removing the battery cables or the batteries with the cover in place may cause a battery explosion resulting in personal injury.

1. Turn the start switch to the OFF position. Turn the ignition switch (if equipped) to the OFF position and remove the key and all electrical loads.
2. Open the battery isolator. Disconnect the negative battery terminal. Ensure that the cable cannot contact the terminal. When four 12 volt batteries are involved, two negative connections must be disconnected.
3. Remove the positive connection.
4. Clean all disconnected connection and battery terminals.
5. Use a fine grade of sandpaper to clean the terminals and the cable clamps. Clean the items until the surfaces are bright or shiny. DO NOT remove material excessively. Excessive removal of material can cause the clamps to not fit correctly. Coat the clamps and the terminals with a suitable silicone lubricant or petroleum jelly.
6. Tape the cable connections to help prevent accidental starting.
7. Proceed with necessary system repairs.
8. To connect the battery, connect the positive connection before the negative connection.

## Cooling System Coolant (Commercial Heavy-Duty) - Change

### NOTICE

Care must be taken to ensure that fluids are contained during performance of inspection, maintenance, testing, adjusting and repair of the product. Be prepared to collect the fluid with suitable containers before opening any compartment or disassembling any component containing fluids.

Dispose of all fluids according to Local regulations and mandates.

### NOTICE

Keep all parts clean from contaminants.

Contaminants may cause rapid wear and shortened component life.

Clean the cooling system and flush the cooling system before the recommended maintenance interval if the following conditions exist:

- The engine overheats frequently.
- Foaming is observed.
- The oil has entered the cooling system and the coolant is contaminated.
- The fuel has entered the cooling system and the coolant is contaminated.

**Note:** When the cooling system is cleaned, only clean water is needed.

**Note:** Inspect the water pump and the water temperature regulator after the cooling system has been drained. During this maintenance procedure, consider replacing the water pump, the water temperature regulator, and the hoses, if necessary.

## Drain

### WARNING

**Pressurized System:** Hot coolant can cause serious burns. To open the cooling system filler cap, stop the engine and wait until the cooling system components are cool. Loosen the cooling system pressure cap slowly in order to relieve the pressure.

1. Stop the engine and allow the engine to cool. Loosen the cooling system filler cap slowly to relieve any pressure. Remove the cooling system filler cap.

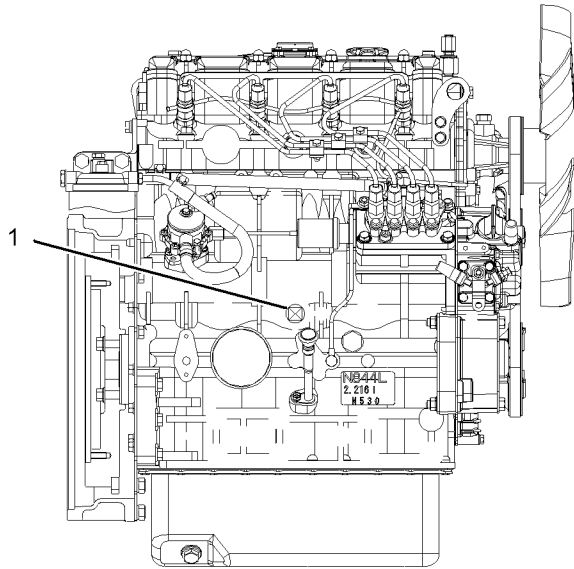

Illustration 42  
Drain plug option

g01301065

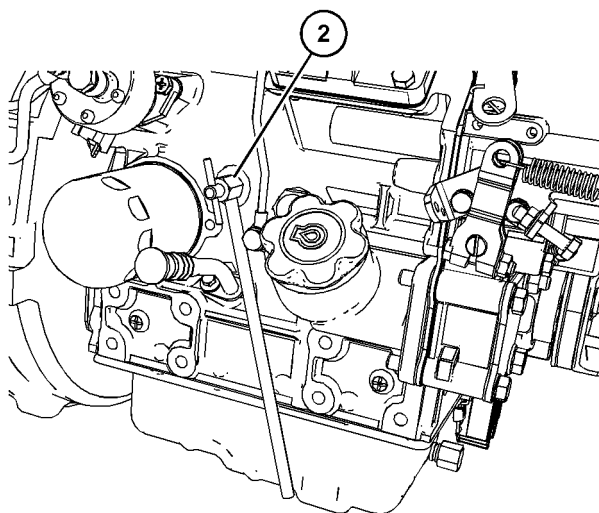

Illustration 43  
Drain tap option

g06518652

2. Remove drain plug (1) or open drain tap (2) for the engine.
3. Remove the drain plug or open the drain tap on the radiator.
4. Allow the coolant to drain.

#### NOTICE

Dispose of used engine coolant or recycle. Various methods have been proposed to reclaim used coolant for reuse in engine cooling systems. The full distillation procedure is the only method acceptable by Perkins to reclaim the coolant.

For information regarding the disposal and the recycling of used coolant, consult your Perkins dealer or your Perkins distributor.

### Flush

1. Flush the cooling system with clean water to remove any debris.
2. Close the drain tap or install the drain plug to the engine.
3. Close the drain tap or install the drain plug on the radiator.

#### NOTICE

Do not fill the cooling system faster than 5 L (1.3 US gal) per minute to avoid air locks.

Cooling system air locks may result in engine damage.

4. Fill the cooling system with clean water. Install the cooling system filler cap.
5. Start and run the engine at low idle until the temperature reaches 49 to 66 °C (120 to 150 °F).
6. Stop the engine and allow the engine to cool. Loosen the cooling system filler cap slowly to relieve any pressure. Remove the cooling system filler cap. Open the drain tap or remove the drain plug on the engine. Open the drain tap or remove the drain plug on the radiator. Allow the water to drain. Flush the cooling system with clean water.

### Fill

1. Close the drain tap or install the drain plug on the engine.
2. Close the drain tap or install the drain plug on the radiator.

#### NOTICE

Do not fill the cooling system faster than 5 L (1.3 US gal) per minute to avoid air locks.

Cooling system air locks may result in engine damage.

Maintenance Section  
Cooling System Coolant (ELC) - Change

---

3. Fill the cooling system with Commercial Heavy-Duty Coolant. Add Supplemental Coolant Additive to the coolant. For the correct amount, refer to the Operation and Maintenance Manual, "Fluid Recommendations" topic (Maintenance Section) for more information on cooling system specifications. Do not install the cooling system filler cap.
4. Start and run the engine at low idle. Increase the engine rpm to high idle. Run the engine at high idle for one minute to purge the air from the cavities of the engine block. Stop the engine.
5. Check the coolant level. Maintain the coolant level within 13 mm (0.5 inch) below the bottom of the pipe for filling. Maintain the coolant level in the expansion bottle (if equipped) at the correct level.
6. Clean the cooling system filler cap. Inspect the gasket that is on the cooling system filler cap. If the gasket that is on the cooling system filler cap is damaged, discard the old cooling system filler cap and install a new cooling system filler cap. If the gasket that is on the cooling system filler cap is not damaged, use a suitable pressurizing pump to pressure test the cooling system filler cap. The correct pressure for the cooling system filler cap is stamped on the face of the cooling system filler cap. If the cooling system filler cap does not retain the correct pressure, install a new cooling system filler cap.
7. Start the engine. Inspect the cooling system for leaks and for correct operating temperature.

i08056235

## Cooling System Coolant (ELC) - Change

---

### NOTICE

Care must be taken to ensure that fluids are contained during performance of inspection, maintenance, testing, adjusting and repair of the product. Be prepared to collect the fluid with suitable containers before opening any compartment or disassembling any component containing fluids.

Dispose of all fluids according to Local regulations and mandates.

---

### NOTICE

Keep all parts clean from contaminants.

Contaminants may cause rapid wear and shortened component life.

---

Clean the cooling system and flush the cooling system before the recommended maintenance interval if the following conditions exist:

- The engine overheats frequently.
- Foaming is observed.
- The oil has entered the cooling system and the coolant is contaminated.
- The fuel has entered the cooling system and the coolant is contaminated.

**Note:** When the cooling system is cleaned, only clean water is needed when the ELC is drained and replaced.

**Note:** Inspect the water pump and the water temperature regulator after the cooling system has been drained. During this maintenance procedure, consider replacing the water pump, the water temperature regulator, and the hoses, if necessary.

## Drain

### WARNING

**Pressurized System: Hot coolant can cause serious burns. To open the cooling system filler cap, stop the engine and wait until the cooling system components are cool. Loosen the cooling system pressure cap slowly in order to relieve the pressure.**

---

1. Stop the engine and allow the engine to cool. Loosen the cooling system filler cap slowly to relieve any pressure. Remove the cooling system filler cap.

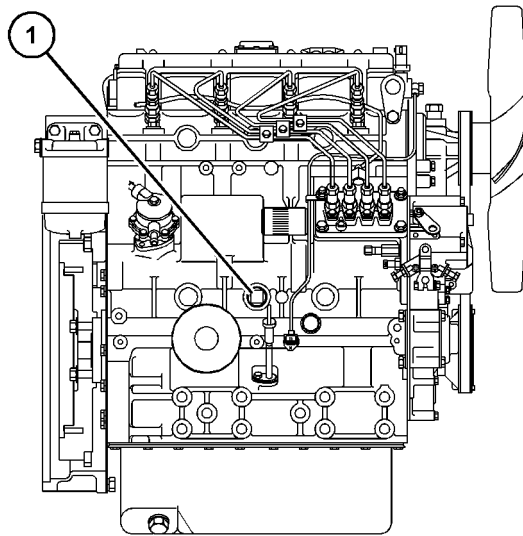

Illustration 44  
Drain plug option

g06518654

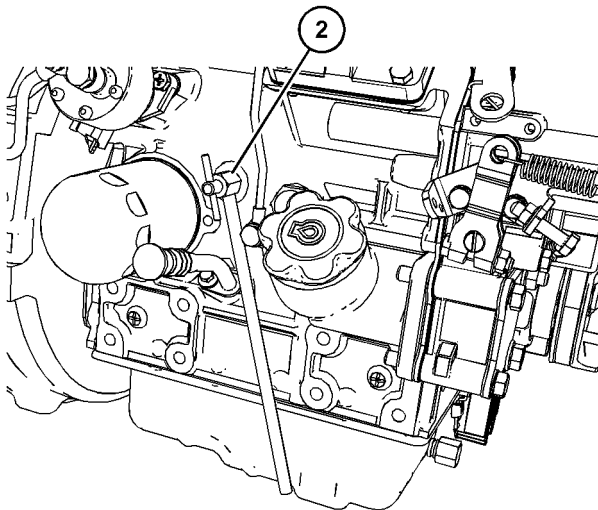

Illustration 45  
Drain tap option

g06518652

2. Remove drain plug (1) or open drain tap (2) for the engine.
3. Remove the drain plug or open the drain tap on the radiator.
4. Allow the coolant to drain.

#### NOTICE

Dispose of used engine coolant or recycle. Various methods have been proposed to reclaim used coolant for reuse in engine cooling systems. The full distillation procedure is the only method acceptable by Perkins to reclaim the coolant.

For information regarding the disposal and the recycling of used coolant, consult your Perkins dealer or your Perkins distributor.

### Flush

1. Flush the cooling system with clean water to remove any debris.
2. Close the drain cock or install the drain plug in the engine. Close the drain cock or install the drain plug on the radiator.

#### NOTICE

Do not fill the cooling system faster than 5 L (1.3 US gal) per minute to avoid air locks.

Cooling system air locks may result in engine damage.

3. Fill the cooling system with clean water. Install the cooling system filler cap.
4. Start and run the engine at low idle until the temperature reaches 49 to 66 °C (120 to 150 °F).
5. Stop the engine and allow the engine to cool. Loosen the cooling system filler cap slowly to relieve any pressure. Remove the cooling system filler cap. Open the drain cock or remove the drain plug on the engine. Open the drain cock or remove the drain plug on the radiator. Allow the water to drain. Flush the cooling system with clean water.

### Fill

1. Close the drain cock or install the drain plug on the engine. Close the drain cock or install the drain plug on the radiator.

#### NOTICE

Do not fill the cooling system faster than 5 L (1.3 US gal) per minute to avoid air locks.

Cooling system air locks may result in engine damage.

Maintenance Section  
Cooling System Coolant Level - Check

2. Fill the cooling system with Extended Life Coolant (ELC). Refer to the Operation and Maintenance Manual, "Fluid Recommendations" topic (Maintenance Section) for more information on cooling system specifications. Do not install the cooling system filler cap.
3. Start and run the engine at low idle. Increase the engine rpm to high idle. Run the engine at high idle for one minute to purge the air from the cavities of the engine block. Stop the engine.
4. Check the coolant level. Maintain the coolant level within 13 mm (0.5 inch) below the bottom of the pipe for filling. Maintain the coolant level in the expansion bottle (if equipped) at the correct level.
5. Clean the cooling system filler cap. Inspect the gasket that is on the cooling system filler cap. If the gasket that is on the cooling system filler cap is damaged, discard the old cooling system filler cap and install a new cooling system filler cap. If the gasket that is on the the cooling system filler cap is not damaged, use a suitable pressurizing pump to pressure test the cooling system filler cap. The correct pressure for the cooling system filler cap is stamped on the face of the cooling system filler cap. If the cooling system filler cap does not retain the correct pressure, install a new cooling system filler cap.
6. Start the engine. Inspect the cooling system for leaks and for correct operating temperature.

i04408743

## Cooling System Coolant Level - Check

### Engines With a Coolant Recovery Tank

**Note:** The cooling system may not have been provided by Perkins. The procedure that follows is for typical cooling systems. Refer to the OEM information for the correct procedures.

Check the coolant level when the engine is stopped and cool.

#### NOTICE

When any servicing or repair of the engine cooling system is performed, the procedure must be performed with the engine on level ground. This will allow you to accurately check the coolant level. This will also help in avoiding the risk of introducing an air lock into the coolant system.

1. Observe the coolant level in the coolant recovery tank. Maintain the coolant level to "COLD FULL" mark on the coolant recovery tank.

#### WARNING

**Pressurized System: Hot coolant can cause serious burns. To open the cooling system filler cap, stop the engine and wait until the cooling system components are cool. Loosen the cooling system pressure cap slowly in order to relieve the pressure.**

2. Loosen filler cap slowly in order to relieve any pressure. Remove the filler cap.
3. Pour the correct coolant mixture into the tank. Refer to the Operation and Maintenance Manual, "Refill Capacities and Recommendations" for information on the correct mixture and type of coolant. Refer to the Operation and Maintenance Manual, "Refill Capacities and Recommendations" for the cooling system capacity. Do not fill the coolant recovery tank above "COLD FULL" mark.

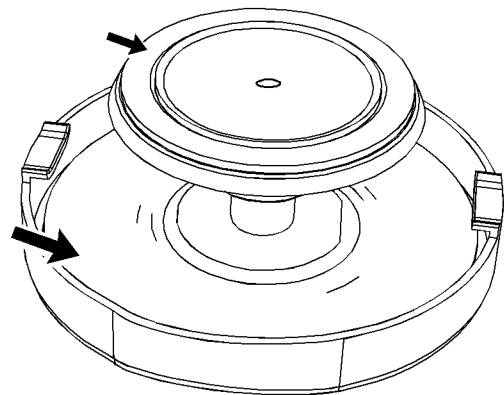

Illustration 46

g02590196

Filler cap

4. Clean filler cap and the receptacle. Reinstall the filler cap and inspect the cooling system for leaks.

**Note:** The coolant will expand as the coolant heats up during normal engine operation. The additional volume will be forced into the coolant recovery tank during engine operation. When the engine is stopped and cool, the coolant will return to the engine.

## Engines Without a Coolant Recovery Tank

Check the coolant level when the engine is stopped and cool.

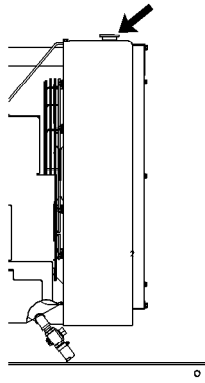

Illustration 47

g00285520

Cooling system filler cap

### **! WARNING**

**Pressurized System: Hot coolant can cause serious burns. To open the cooling system filler cap, stop the engine and wait until the cooling system components are cool. Loosen the cooling system pressure cap slowly in order to relieve the pressure.**

1. Remove the cooling system filler cap slowly in order to relieve pressure.
2. Maintain the coolant level at the maximum mark that is correct for your application. If the engine is equipped with a sight glass, maintain the coolant level to the correct level in the sight glass.
3. Clean the cooling system filler cap and inspect the gasket. If the gasket is damaged, discard the old filler cap and install a new filler cap. If the gasket is not damaged, use a suitable pressurizing pump in order to pressure test the filler cap. The correct pressure is stamped on the face of the filler cap. If the filler cap does not retain the correct pressure, install a new filler cap.

4. Inspect the cooling system for leaks.

i03644948

## Cooling System Supplemental Coolant Additive (SCA) - Test/Add

### **! WARNING**

**Cooling system coolant additive contains alkali. To help prevent personal injury, avoid contact with the skin and the eyes. Do not drink cooling system coolant additive.**

## Test for SCA Concentration

### Heavy-Duty Coolant/Antifreeze and SCA

#### NOTICE

Do not exceed the recommended six percent supplemental coolant additive concentration.

Use a Coolant Conditioner Test Kit in order to check the concentration of the SCA.

## Add the SCA, If Necessary

#### NOTICE

Do not exceed the recommended amount of supplemental coolant additive concentration. Excessive supplemental coolant additive concentration can form deposits on the higher temperature surfaces of the cooling system, reducing the engine's heat transfer characteristics. Reduced heat transfer could cause cracking of the cylinder head and other high temperature components. Excessive supplemental coolant additive concentration could also result in radiator tube blockage, overheating, and/or accelerated water pump seal wear. Never use both liquid supplemental coolant additive and the spin-on element (if equipped) at the same time. The use of those additives together could result in supplemental coolant additive concentration exceeding the recommended maximum.

### **! WARNING**

**Pressurized System: Hot coolant can cause serious burns. To open the cooling system filler cap, stop the engine and wait until the cooling system components are cool. Loosen the cooling system pressure cap slowly in order to relieve the pressure.**

Maintenance Section  
Cooling System Water Temperature Regulator - Replace

---



---

**NOTICE**

When any servicing or repair of the engine cooling system is performed the procedure must be performed with the engine on level ground. This will allow you to accurately check the coolant level. This will also help in avoiding the risk of introducing an air lock into the coolant system.

---

1. Slowly loosen the cooling system filler cap in order to relieve the pressure. Remove the cooling system filler cap.

**Note:** Always discard drained fluids according to local regulations.

2. If necessary, drain some coolant from the cooling system into a suitable container in order to allow space for the extra SCA.
3. Add the correct amount of SCA. Refer to the Operation and Maintenance Manual, "Refill Capacities and Recommendations" for more information on SCA requirements.
4. Clean the cooling system filler cap and inspect the gasket. If the gasket is damaged, discard the old filler cap and install a new filler cap. If the gasket is not damaged, use a suitable pressurizing pump in order to pressure test the filler cap. The correct pressure is stamped on the face of the filler cap. If the filler cap does not retain the correct pressure, install a new filler cap.

i03632420

## Cooling System Water Temperature Regulator - Replace

Replace the water temperature regulator before the water temperature regulator fails. This is a recommended preventive maintenance practice. Replacing the water temperature regulator reduces the chances for unscheduled downtime.

A water temperature regulator that fails in a partially opened position can cause overheating or overcooling of the engine.

A water temperature regulator that fails in the closed position can cause excessive overheating. Excessive overheating could result in cracking of the cylinder head or piston seizure problems.

A water temperature regulator that fails in the open position will cause the engine operating temperature to be too low during partial load operation. Low engine operating temperatures during partial loads could cause an excessive carbon buildup inside the cylinders. This excessive carbon buildup could result in an accelerated wear of the piston rings and wear of the cylinder liner.

---

**NOTICE**

Failure to replace your water temperature regulator on a regularly scheduled basis could cause severe engine damage.

Perkins engines incorporate a shunt design cooling system and require operating the engine with a water temperature regulator installed.

If the water temperature regulator is installed incorrectly, the engine may overheat, causing cylinder head damage. Ensure that the new water temperature regulator is installed in the original position. Ensure that the water temperature regulator vent hole is open.

Do not use liquid gasket material on the gasket or cylinder head surface.

---

Refer to the Disassembly and Assembly Manual, "Water Temperature Regulator - Remove and Install" for the replacement procedure of the water temperature regulator, or consult your Perkins dealer or your Perkins distributor.

**Note:** If only the water temperature regulators are replaced, drain the coolant from the cooling system to a level that is below the water temperature regulator housing.

i02151646

## Driven Equipment - Check

Refer to the OEM specifications for more information on the following maintenance recommendations for the driven equipment:

- Inspection
- Adjustment
- Lubrication
- Other maintenance recommendations

Perform any maintenance for the driven equipment which is recommended by the OEM.



i06791792

i08154921

## Engine - Clean

### WARNING

Personal injury or death can result from high voltage.

Moisture can create paths of electrical conductivity.

Make sure that the electrical system is OFF. Lock out the starting controls and tag the controls "DO NOT OPERATE" .

### NOTICE

Accumulated grease and oil on an engine is a fire hazard. Keep the engine clean. Remove debris and fluid spills whenever a significant quantity accumulates on the engine.

Periodic cleaning of the engine is recommended. Steam cleaning the engine will remove accumulated oil and grease. A clean engine provides the following benefits:

- Easy detection of fluid leaks
- Maximum heat transfer characteristics
- Ease of maintenance

**Note:** Caution must be used to prevent electrical components from being damaged by excessive water when the engine is cleaned. Do not be directed the nozzle of the cleaner at any electrical connectors or the junction of cables into the rear of the connectors. Avoid electrical components such as the alternator, and the starter. Protect the fuel injection pump from fluids to wash the engine.

Ensure that care is taken that the safety labels, emission label, and all other information labels are not removed during engine cleaning.

## Engine Air Cleaner Element - Replace

### NOTICE

Never run the engine without an air cleaner element installed. Never run the engine with a damaged air cleaner element. Do not use air cleaner elements with damaged pleats, gaskets or seals. Dirt entering the engine causes premature wear and damage to engine components. Air cleaner elements help to prevent airborne debris from entering the air inlet.

### NOTICE

Never service the air cleaner element with the engine running since this will allow dirt to enter the engine.

## Servicing the Air Cleaner Elements

**Note:** The air filter system may not have been provided by Perkins. The procedure that follows, is for a typical air filter system. Refer to the OEM information for the correct procedure.

If the air cleaner element becomes plugged, the air can split the material of the air cleaner element. Unfiltered air will drastically accelerate internal engine wear. Refer to the OEM information for the correct air cleaner elements for your application.

- Check the pre-cleaner (if equipped) and the dust bowl daily for accumulation of dirt and debris. Remove any dirt and debris, as needed.
- Operating in dirty conditions may require more frequent service of the air cleaner element.
- The air cleaner element should be replaced at least one time per year.

Replace the dirty air cleaner elements with clean air cleaner elements. Before installation, the new air cleaner elements should be thoroughly checked for tears and/or holes in the filter material. Inspect the gasket or the seal of the air cleaner element for damage. Maintain a supply of suitable air cleaner elements for replacement purposes.

### Air Cleaners

Some application can have dual elements. The dual air cleaner contains a primary air cleaner element and a secondary air cleaner element. Both element must be replaced at the same time.

Do not replace the air cleaner filter elements in a dirty environment, as dirt can enter the air system when the elements are removed.

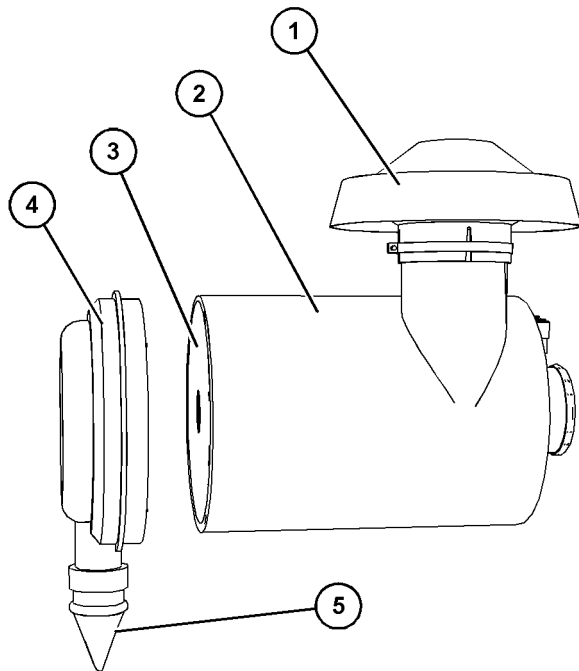

Illustration 48

g06217098

### Typical example

- (1) Top Cover
- (2) Air Cleaner Body
- (3) Primary Air Filter Element
- (4) End Cover
- (5) Vacuum Valve

1. Ensure that the outer body of the air cleaner to be serviced is clean and free from dirt.
2. Inspect the top cover (1) and if necessary remove top cover to clean cover. Ensure that dirt cannot enter the air cleaner system with top cover removed. If necessary, clean top cover and install.
3. Remove end cover (4) from air cleaner body (2). If necessary, clean end cover and ensure that the vacuum valve (5) is clean and free from dirt. Check the vacuum valve (5) for wear or damage, replace if necessary.
4. Remove primary air filter element (3) and if equipped, remove the secondary air filter element (Not Shown). Discard all old air filter elements.
5. If equipped, install new secondary air filter element (Not Shown) and install new primary air filter element (3).

6. Install end cover (4) to air cleaner body (2) and secure end cover. If necessary, reset the air service indicator, refer to this Operation and Maintenance Manual, Engine Air Cleaner Service Indicator - Inspect for more information.

i02335405

## Engine Air Cleaner Service Indicator - Inspect

Some engines may be equipped with a different service indicator.

Some engines are equipped with a differential gauge for inlet air pressure. The differential gauge for inlet air pressure displays the difference in the pressure that is measured before the air cleaner element and the pressure that is measured after the air cleaner element. As the air cleaner element becomes dirty, the pressure differential rises. If your engine is equipped with a different type of service indicator, follow the OEM recommendations in order to service the air cleaner service indicator.

The service indicator may be mounted on the air cleaner element or in a remote location.

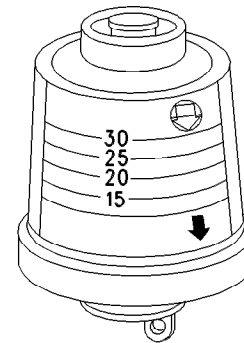

Illustration 49

g00103777

### Typical service indicator

Observe the service indicator. The air cleaner element should be cleaned or the air cleaner element should be replaced when one of the following conditions occur:

- The yellow diaphragm enters the red zone.
- The red piston locks in the visible position.

## Test the Service Indicator

Service indicators are important instruments.

- Check for ease of resetting. The service indicator should reset in less than three pushes.

- Check the movement of the yellow core when the engine is accelerated to the engine rated speed. The yellow core should latch at the greatest vacuum that is attained.

If the service indicator does not reset easily, or if the yellow core does not latch at the greatest vacuum, the service indicator should be replaced. If the new service indicator will not reset, the hole for the service indicator may be restricted.

The service indicator may need to be replaced frequently in environments that are severely dusty.

i07819526

## Engine Air Precleaner - Check/Clean

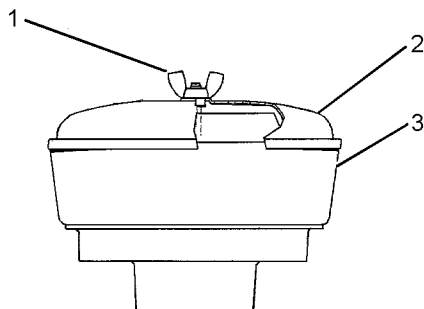

Illustration 50

g01453058

### Typical engine air precleaner

- (1) Wing nut
- (2) Cover
- (3) Body

Remove wing nut (1) and cover (2). Check for an accumulation of dirt and debris in body (3). Clean the body, if necessary.

After cleaning the precleaner, install cover (2) and wing nut (1).

**Note:** When the engine is operated in dusty conditions, more frequent cleaning is required.

Do not tap or strike the air cleaner element.

i02657627

## Engine Crankcase Breather - Replace

### NOTICE

Keep all parts clean from contaminants.

Contaminants may cause rapid wear and shortened component life.

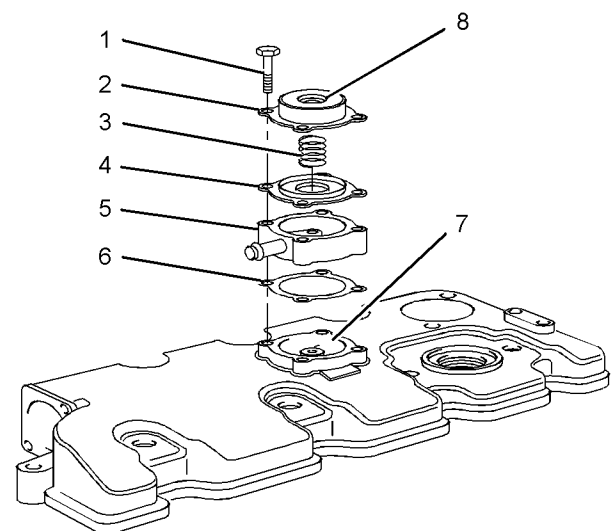

Illustration 51

g01335247

### Typical example

- (1) Screws for the breather cover
- (2) Breather cover
- (3) Spring
- (4) Diaphragm and plate
- (5) Spacer for turbocharged engines only
- (6) Joint for turbocharged engines only
- (7) Cavity
- (8) Vent hole

1. Loosen the screws (1) and remove the breather cover (2) from the valve mechanism cover.
2. Remove the spring (3). Remove the diaphragm and plate (4).
3. For turbocharged engines, remove the spacer (5) and the joint (6).

4. Clean the vent hole (8) and the cavity (7) in the valve mechanism cover.

**NOTICE**

Make sure that the components of the breather assembly are installed correctly. Engine damage may occur if the breather assembly is not working correctly.

5. For turbocharged engines, install a new joint (6) and the spacer (5).
6. Install a new diaphragm and plate (4) for the breather assembly into the cavity (7) of the valve mechanism cover or the spacer (5) for turbocharged engines.
7. Install a new spring (3).
8. Install the breather cover (2) and the four screws (1). Tighten the screws.

i07819538

## Engine Mounts - Inspect

**Note:** The engine mounts may not have been supplied by Perkins. Refer to the Original Equipment Manufacturer (OEM) information for further details on the engine mounts and the correct bolt torque.

Inspect the engine mounts for deterioration and for correct bolt torque. Excessive engine vibration can be caused by the following conditions:

- Incorrect mounting of the engine
- Deterioration of the engine mounts
- Loose engine mounts

Any engine mount that shows deterioration should be replaced. Refer to the OEM information for the recommended torques.

When the engine mounts are supplied by Perkins the maintenance procedure will be supplied in the Disassembly and Assembly manual for your engine.

i06812544

## Engine Oil Level - Check

**⚠ WARNING**

Hot oil and hot components can cause personal injury. Do not allow hot oil or hot components to contact the skin.

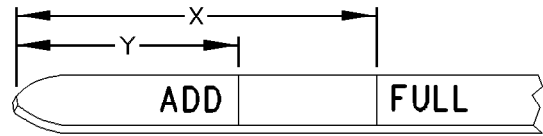

Illustration 52

g00110310

(Y) "ADD" mark. (X) "FULL" mark.

**NOTICE**

Perform this maintenance with the engine stopped.

1. Maintain the oil level between "ADD" mark (Y) and "FULL" mark (X) on oil level gauge (1). Do not fill the crankcase above "FULL" mark (X).

**NOTICE**

Operating your engine when the oil level is above the "FULL" mark could cause your crankshaft to dip into the oil. The air bubbles created from the crankshaft dipping into the oil reduces the oil's lubricating characteristics and could result in the loss of power or engine failure.

2. Remove the oil filler cap and add oil, if necessary. Clean the oil filler cap. Install the oil filler cap.

i08155318

## Engine Oil and Filter - Change

**⚠ WARNING**

Hot oil and hot components can cause personal injury. Do not allow hot oil or hot components to contact the skin.

**NOTICE**

Care must be taken to ensure that fluids are contained during performance of inspection, maintenance, testing, adjusting and repair of the product. Be prepared to collect the fluid with suitable containers before opening any compartment or disassembling any component containing fluids.

Dispose of all fluids according to local regulations and mandates.

**NOTICE**

Keep all parts clean from contaminants.

Contaminants may cause rapid wear and shortened component life.

Do not drain the oil when the engine is cold. As the oil cools, suspended waste particles settle on the bottom of the oil pan. The waste particles are not removed with the draining cold oil. Drain the crankcase with the engine stopped. Drain the crankcase with the oil warm. This draining method allows the waste particles that are suspended in the oil to be drained correctly.

Failure to follow this recommended procedure will cause the waste particles to be recirculated through the engine lubrication system with the new oil.

## Drain the Engine Oil

After the engine has been run at the normal operating temperature, stop the engine. Use one of the following methods to drain the engine crankcase oil:

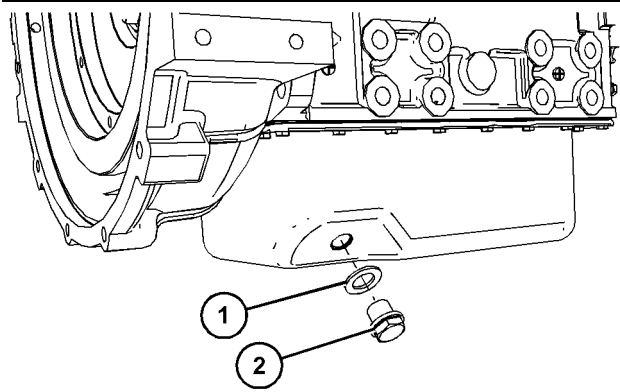

Illustration 53

g06518218

1. Remove drain plug (2) from the engine oil pan and drain the oil into a suitable container for storage or disposal.
2. Remove sealing washer (1) from the drain plug and clean the oil drain plug.
3. Install new sealing washer (1) to the drain plug.
4. Install drain plug (2) to the engine oil pan. Tighten the drain plug to a torque of 34 N·m (300.93 lb in)

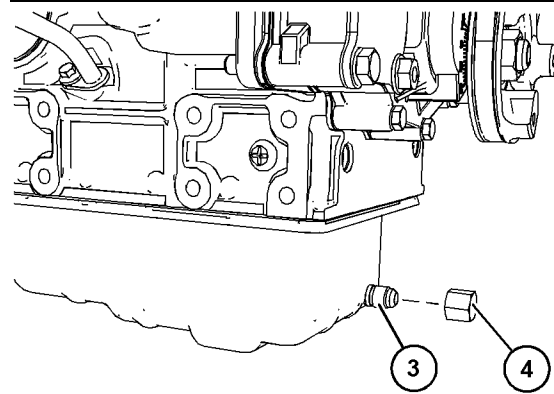

Illustration 54

g06518231

1. Remove drain cap (4) from engine oil pan outlet (3) and drain the oil into a suitable container for storage or disposal.
2. Clean the oil drain cap.
3. Install drain cap (4) to the engine oil pan outlet (3). Tighten the drain cap to a torque of 18 N·m (159.31 lb in).

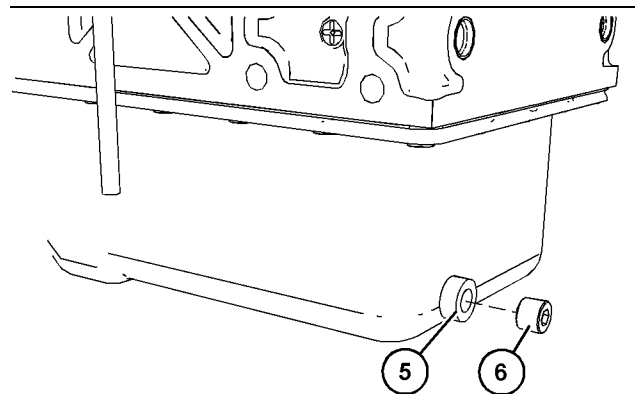

Illustration 55

g06523773

1. Remove drain plug (6) from engine oil pan outlet (5) and drain the oil into a suitable container for storage or disposal.
2. Clean oil drain plug (6).
3. Install drain plug (6) to engine oil pan outlet (5). Tighten the drain plug to a torque of 26 N·m (230.12 lb in).

- If the engine is equipped with a drain valve, turn the drain valve knob counterclockwise to drain the oil. After the oil has drained, turn the drain valve knob clockwise to close the drain valve.

## Replace the Oil Filter

### NOTICE

Perkins oil filters are built to Perkins specifications. Use of an oil filter not recommended by Perkins could result in severe engine damage to the engine bearings, crankshaft, etc., as a result of the larger waste particles from unfiltered oil entering the engine lubricating system. Only use oil filters recommended by Perkins.

1. Remove the oil filter with a suitable tool.

**Note:** The following actions can be carried out as part of the preventive maintenance program.

2. Cut the oil filter open with a suitable tool. Break apart the pleats and inspect the oil filter for metal debris. An excessive amount of metal debris in the oil filter may indicate early wear or a pending failure.

Use a magnet to differentiate between the ferrous metals and the non-ferrous metals that are found in the oil filter element. Ferrous metals may indicate wear on the steel and cast iron parts of the engine.

Non-ferrous metals may indicate wear on the aluminum parts, brass parts, or bronze parts of the engine. Parts that may be affected include the following items: main bearings, rod bearings, turbocharger bearings, and cylinder heads.

Due to normal wear and friction, it is not uncommon to find small amounts of debris in the oil filter. Consult your Perkins dealer or your Perkins distributor to arrange for a further analysis if an excessive amount of debris is found in the oil filter.

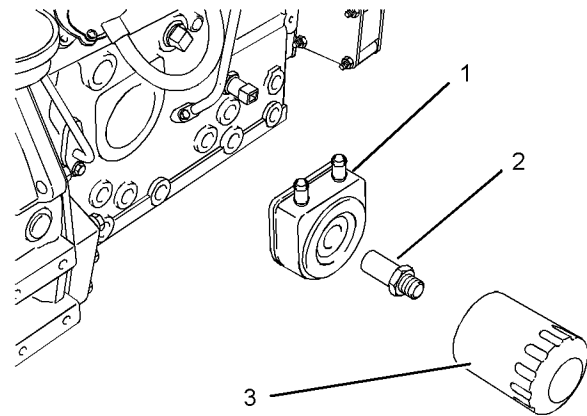

Illustration 56

g01334593

- (1) Oil cooler  
 (2) Adapter  
 (3) Oil filter

**Note:** The oil cooler (1) and the adapter (2) are installed on engines that have a turbocharger.

3. Clean the sealing surface of the cylinder block or the oil cooler (1).
4. Apply clean engine oil to the new oil filter seal (3).

### NOTICE

Do not fill the oil filters with oil before installing them. This oil would not be filtered and could be contaminated. Contaminated oil can cause accelerated wear to engine components or engine damage.

5. Install the oil filter. Tighten the oil filter by hand. Do not overtighten the oil filter.

## Fill the Engine Crankcase

1. Remove the oil filler cap. Refer to this Operation and Maintenance Manual, Fluid Recommendations for more information on lubricant specifications.

Fill the crankcase with the correct amount of oil. Refer to this Operation and Maintenance Manual, Refill Capacities for more information on refill capacities.

**NOTICE**

If equipped with an auxiliary oil filter system or a remote oil filter system, follow the OEM or filter manufacturer's recommendations. Under filling or overfilling the crankcase with oil can cause engine damage.

**NOTICE**

To prevent crankshaft bearing damage, crank the engine with the fuel OFF. This will fill the oil filters before starting the engine. Do not crank the engine for more than 30 seconds.

2. Start the engine and run the engine at "LOW IDLE" for two minutes. Perform this procedure to ensure that the lubrication system has oil and that the oil filters are filled. Inspect the oil filter for oil leaks.
3. Stop the engine and allow the oil to drain back to the sump for a minimum of ten minutes.

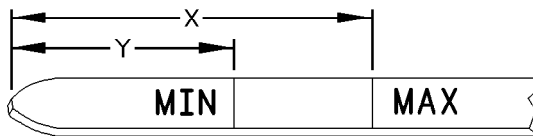

Illustration 57

g00986928

Typical example

4. Remove the oil level gauge to check the oil level. Maintain the oil level between the "MIN" and "MAX" marks on the oil level gauge.

i02676023

## Engine Valve Lash - Inspect/Adjust

This maintenance is recommended by Perkins as part of a lubrication and preventive maintenance schedule in order to help provide maximum engine life. The maintenance for the valve lash is important in order to keep the engine compliant.

**NOTICE**

Only qualified service personnel should perform this maintenance. Refer to the Service Manual or your authorized Perkins dealer or your Perkins distributor for the complete valve lash adjustment procedure.

Operation of Perkins engines with incorrect valve lash can reduce engine efficiency, and also reduce engine component life.

### **WARNING**

**Ensure that the engine can not be started while this maintenance is being performed. To help prevent possible injury, do not use the starting motor to turn the flywheel.**

**Hot engine components can cause burns. Allow additional time for the engine to cool before measuring/adjusting valve lash clearance.**

Ensure that the engine is stopped before measuring the valve lash. The engine valve lash can be inspected and adjusted when the temperature of the engine is hot or cold.

Refer to Systems Operation, Testing and Adjusting, "Engine Valve Lash - Inspect/Adjust" for more information.

i02154268

## Fuel Injector - Test/Change

### **WARNING**

**Fuel leaked or spilled onto hot surfaces or electrical components can cause a fire.**

### **WARNING**

**Make sure that you wear eye protection at all times during testing. When fuel injection nozzles are tested, test fluids travel through the orifices of the nozzle tip with high pressure. Under this amount of pressure, the test fluid can pierce the skin and cause serious injury to the operator. Always keep the tip of the fuel injection nozzle pointed away from the operator and into the fuel collector and extension.**

**NOTICE**

Do not allow dirt to enter the fuel system. Thoroughly clean the area around a fuel system component that will be disconnected. Fit a suitable cover over any disconnected fuel system components.

Regular maintenance of the fuel injectors is recommended by Perkins. The fuel injectors must be removed and tested by an authorized agent. The fuel injectors should not be cleaned as cleaning with incorrect tools can damage the nozzle. The fuel injectors should be renewed only if a fault with the fuel injectors occurs. Some of the problems that may indicate that new fuel injectors are needed are listed below:

- The engine will not start or the engine is difficult to start.

- Not enough power
- The engine misfires or the engine runs erratically.
- High fuel consumption
- Black exhaust smoke
- The engine knocks or there is vibration in the engine.
- Excessive engine temperature

For further information on the removal and the installation of the fuel injectors, refer to the Disassembly and Assembly manual.

For further information on the testing of fuel injectors, refer to the Testing and Adjusting manual.

## Identification of a suspect Fuel Injector

### **WARNING**

**Work carefully around an engine that is running. Engine parts that are hot, or parts that are moving, can cause personal injury.**

---

#### NOTICE

If your skin comes into contact with high pressure fuel, obtain medical assistance immediately.

---

#### NOTICE

If a fuel injector is suspected of operating outside of normal parameters it should be removed by a qualified technician. The suspect fuel injector should be taken to an authorised agent for inspection.

---

Operate the engine at a fast idle speed in order to identify the faulty fuel injector. Individually loosen and tighten the union nut for the high pressure pipe to each fuel injector. Do not loosen the union nut more than half a turn. There will be little effect on the engine speed when the union nut to the faulty fuel injector is loosened.

Consult your authorized Perkins dealer or your Perkins distributor for further assistance.

i08046563

## Fuel System - Prime

---

#### NOTICE

Care must be taken to ensure that fluids are contained during performance of inspection, maintenance, testing, adjusting and repair of the product. Be prepared to collect the fluid with suitable containers before opening any compartment or disassembling any component containing fluids.

Dispose of all fluids according to local regulations and mandates.

---

Use the following procedure to prime the fuel system:

If air enters the fuel system, the air must be purged from the fuel system before the engine can be started. Air can enter the fuel system when the following events occur:

- The fuel tank is empty or the fuel tank has been partially drained.
  - The low-pressure fuel lines are disconnected.
  - A leak exists in the low-pressure fuel system.
  - The fuel filter is replaced.
- 

#### NOTICE

Care must be taken to ensure that fluids are contained during performance of inspection, maintenance, testing, adjusting and repair of the product. Be prepared to collect the fluid with suitable containers before opening any compartment or disassembling any component containing fluids.

Dispose of all fluids according to local regulations and mandates.

---

## Primary filter

Ensure that the air is removed from the primary fuel filter before you prime the secondary fuel filters, refer to illustration 58 .



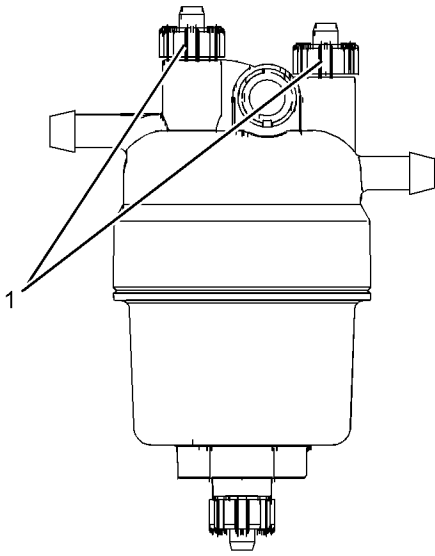

Illustration 58

g01316878

This filter may not be installed on the engine.

(1) Vent screws

## Fuel filters

There are three types of fuel filter that may be installed on the engine.

- Element
- Canister
- Spin-on filter with fuel priming pump

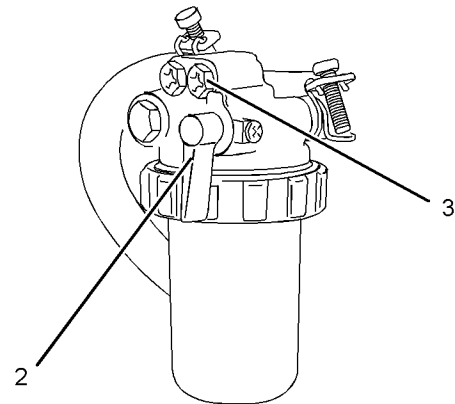

Illustration 59

g01327360

**Element**

(2) Fuel valve  
(3) Vent screw

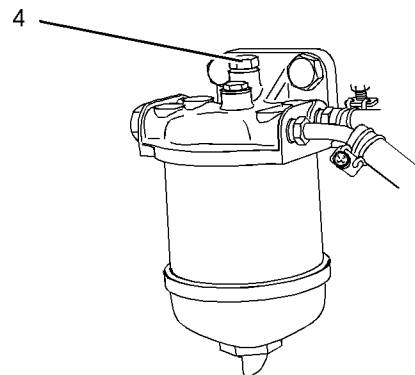

Illustration 60

g01327361

**Canister**

(4) Vent screw

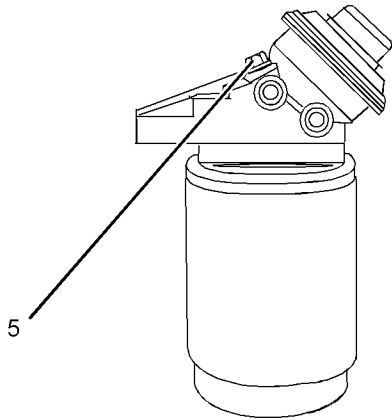

Illustration 61

g01327363

### Spin-on filter with fuel priming pump

(5) Vent screw

Vent screw (3) is installed on the filter that has an element. Vent screw (4) is installed on the fuel filter that has a canister. Vent screw (5) is installed on the spin-on filter.

## Priming the system

Ensure that the air is removed from the primary filter. Loosen vent screws (1). Refer to illustration 58 . Operate the priming pump. When fuel free from air flows from the vent screw tighten the vent screw.

**Note:** Some fuel system will use gravity to prime the primary fuel filter. If gravity is used ensure that the fuel tank is full and that all stop valves in the fuel line are open.

There are four different types of systems that can be installed on the engine to prime the fuel system. Refer to illustration 62 .

- Hand priming pump
- In-line hand priming pump
- Electrical priming pump
- Transfer pump that is operated by the starting motor

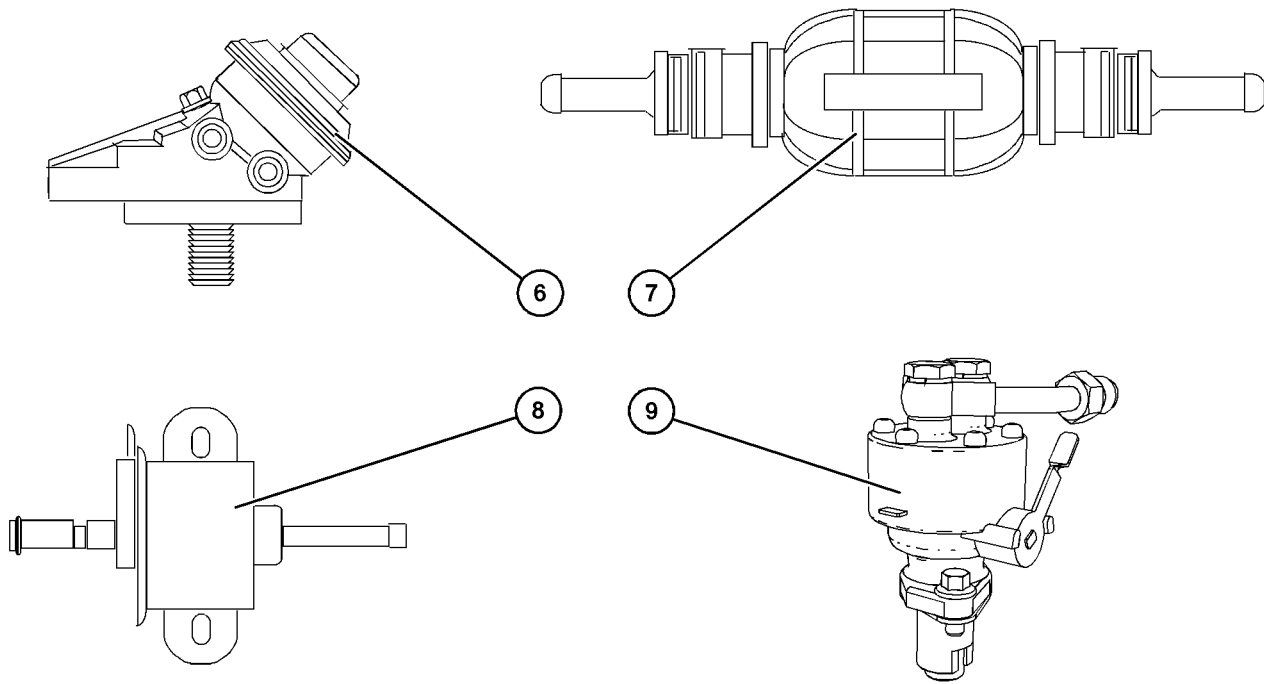

Illustration 62

g06523817

(6) Hand priming pump  
(7) In-line priming pump

(8) Electrical priming pump  
(9) Fuel transfer pump with hand priming

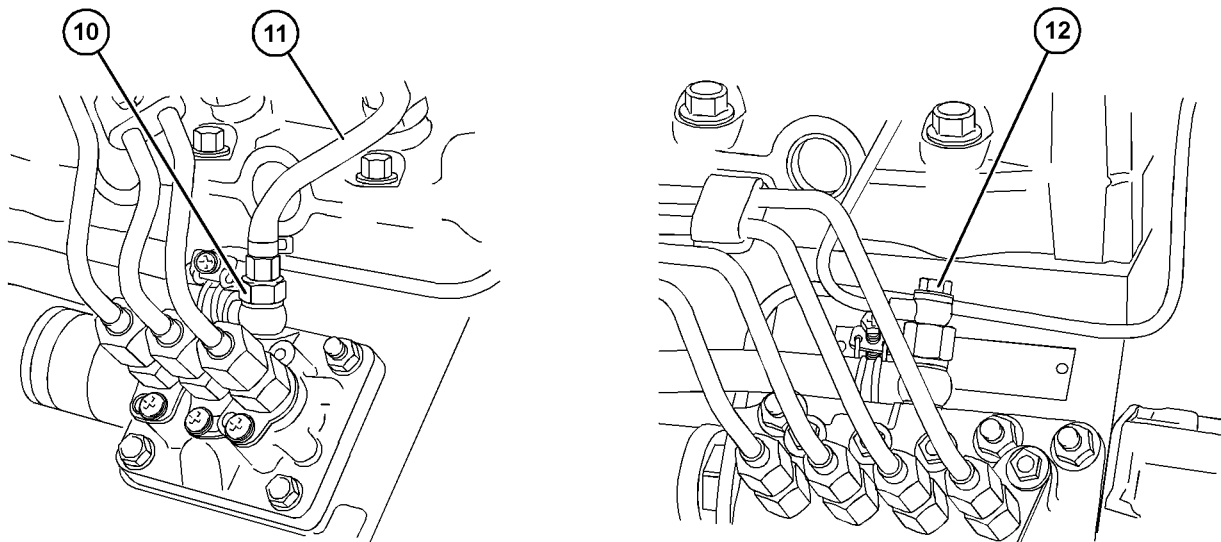

Illustration 63

g06523835

(10) Connector bolt

(11) Fuel return line

(12) Connector bolt

### Hand Priming Pump 6

To identify the hand priming pump, refer to illustration 62 .

1. Ensure that fuel valve (2) for the fuel filter that has an element is in the ON position. Refer to illustration 59 .

2. Loosen vent screw (3 4 or 5) on the fuel filter.
3. Operate hand priming pump (6). When fuel free from air flows from the vent screw tighten the vent screw.
4. Loosen connection (10 or 12) at the fuel injection pump. Refer to illustration 63 .

**Note:** Fuel return line (11) may need to be removed to prime the fuel system.

5. Operate the hand priming pump. When fuel free from air flows from the connections tighten the connecting bolt.
6. The engine should now be able to start. Operate the starting motor to start the engine.

**Note:** Do not operate the starting motor for more than 15 seconds. If the engine does not start after 15 seconds, stop and wait for 30 seconds before trying again.

### In-line Priming Pump 7

To identify the in-line priming pump, refer to illustration 62 .

1. Ensure that fuel valve (2) for the fuel filter that has an element is in the ON position. Refer to illustration 59 .
2. Loosen vent screw (3 4 or 5) on the fuel filter.
3. Operate in-line priming pump (7). When fuel free from air flows from the vent screw tighten the vent screw.
4. Loosen connection (10 or 12) at the fuel injection pump. Refer to illustration 63 .

**Note:** Fuel return line (11) may need to be removed to prime the fuel system.

5. Operate the in-line priming pump. When fuel free from air flows from the connections tighten the connecting bolt.
6. The engine should now be able to start. Operate the starting motor to start the engine.

**Note:** Do not operate the starting motor for more than 15 seconds. If the engine does not start after 15 seconds, stop and wait for 30 seconds before trying again.

### Electrical Priming Pump 8

To identify the electrical priming pump, refer to illustration 62 .

1. Ensure that fuel valve (2) for the fuel filter that has an element is in the ON position. Refer to illustration 59 .
2. Loosen vent screw (3 4 or 5) on the fuel filter.
3. Operate electrical priming pump (8). When fuel free from air flows from the vent screw tighten the vent screw. Switch off the electrical priming pump.
4. Loosen connection (10 or 12) at the fuel injection pump. Refer to illustration 63 .

**Note:** Fuel return line (11) may need to be removed to prime the fuel system.

5. Operate the in-line priming pump. When fuel free from air flows from the connections tighten the connecting bolt.
6. The engine should now be able to start. Operate the starting motor to start the engine.

**Note:** Do not operate the starting motor for more than 15 seconds. If the engine does not start after 15 seconds, stop and wait for 30 seconds before trying again.

### Fuel Transfer Pump 9

To identify the fuel transfer pump, refer to illustration 62 .

**Note:** If the transfer pump is not equipped with a manual priming lever and the engine is not equipped with any other priming option, you must operate the starting motor to prime the fuel system. Do not operate the starting motor for more than 15 seconds continuously. After 15 seconds, stop and wait for 30 seconds before operating the starting motor again.

1. Ensure that fuel valve (2) for the fuel filter that has an element is in the ON position. Refer to illustration 59 .
2. Loosen vent screw (3 4 or 5) on the fuel filter.
3. Operate fuel transfer pump (9). When fuel free from air flows from the vent screw tighten the vent screw. Stop the fuel transfer pump.
4. Loosen connection (10 or 12) at the fuel injection pump. Refer to illustration 63 .

**Note:** Fuel return line (11) may need to be removed to prime the fuel system.

5. Operate the fuel transfer pump. When fuel free from air flows from the connections tighten the connecting bolt. Stop the transfer pump.
6. The engine should now be able to start. Operate the starting motor to start the engine.

**Note:** Do not operate the starting motor for more than 15 seconds. If the engine does not start after 15 seconds, stop and wait for 30 seconds before trying again.

i08046690

## Fuel System Filter - Replace

### WARNING

Fuel leaked or spilled onto hot surfaces or electrical components can cause a fire. To help prevent possible injury, turn the start switch off when changing fuel filters or water separator elements. Clean up fuel spills immediately.

### NOTICE

Do not allow dirt to enter the fuel system. Thoroughly clean the area around a fuel system component that will be disconnected. Fit a suitable cover over any disconnected fuel system components.

### NOTICE

Care must be taken to ensure that fluids are contained during performance of inspection, maintenance, testing, adjusting and repair of the product. Be prepared to collect the fluid with suitable containers before opening any compartment or disassembling any component containing fluids.

Dispose of all fluids according to local regulations and mandates.

## Fuel Filter with Canister

1. Close the fuel supply valve.

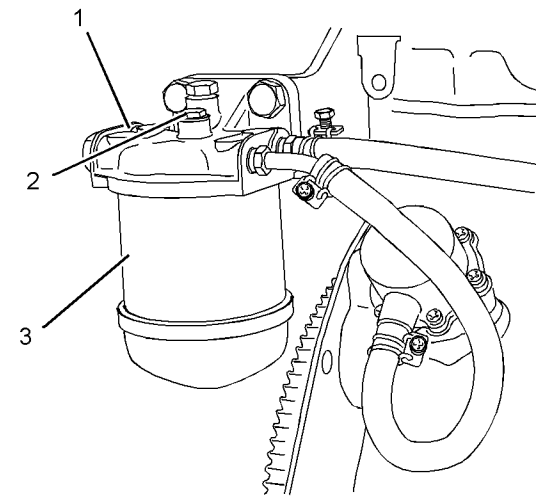

Illustration 64

g01307792

Typical example

2. Clean the outside of the fuel filter assembly (1).
3. Remove setscrew (2).
4. Remove the canister (3). Ensure that any fluid is drained into a suitable container.

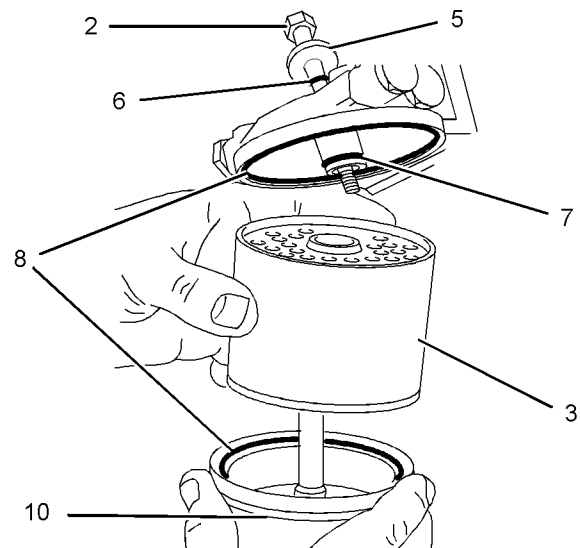

Illustration 65

g01334877

Typical example

5. Assemble the following items: seals (8), seal (7), canister (3), and bowl (10). Place washer (5) and seal (6) on setscrew (2).

Maintenance Section  
Fuel System Filter - Replace

6. Fasten the assembly to the fuel filter base with setscrew (2).
7. Open the fuel supply valve.

The fuel system will need to be primed after the new filter is installed. Refer to this Operation and Maintenance Manual, "Fuel System - Prime" for the correct procedure.

## Fuel Filter with Element

1. Close the fuel supply valve (1).

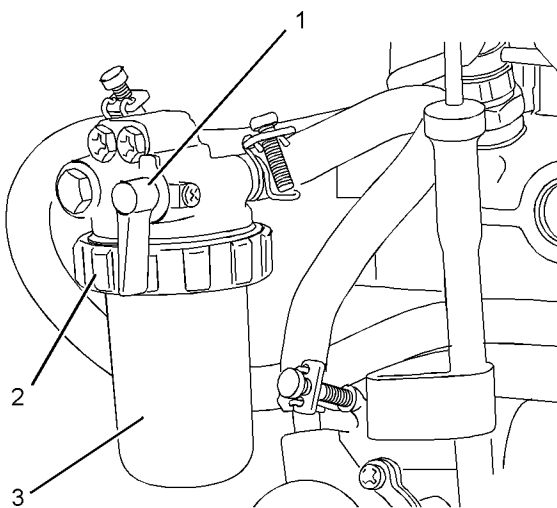

Illustration 66

g01334893

Typical example

2. Clean the outside of the fuel filter assembly.
3. Loosen the locking ring (2).
4. Remove the casing (3) for the filter and the element. Ensure that any fluid is drained into a suitable container.

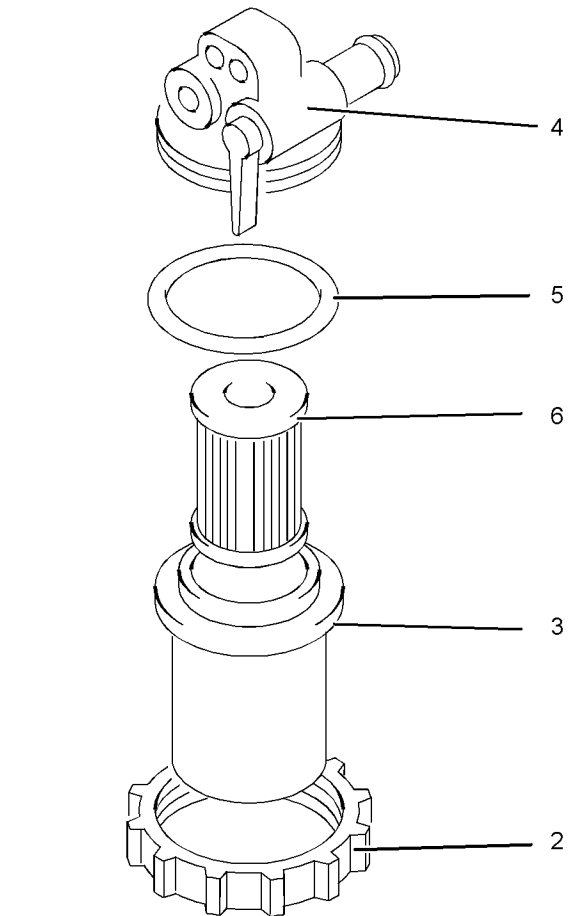

Illustration 67

g01334895

Typical example

- Note:** Do not fill the fuel filter with fuel. The fuel will not be filtered and the fuel could be contaminated. Contaminated fuel can damage your fuel system.
5. Assemble the following items: seal (5), filter element (6), and casing (3).
  6. Install the assembled items to the filter base (4).
  7. Install the locking ring (2) to the filter head. Rotate the locking ring to lock the assembly.
  8. Open the fuel supply valve.

The fuel system will need to be primed after the new filter is installed. Refer to this Operation and Maintenance Manual, "Fuel System - Prime" for the correct procedure.

## Fuel Filter with Priming Pump

1. Close the fuel supply valve.
2. Clean the outside of the fuel filter assembly.

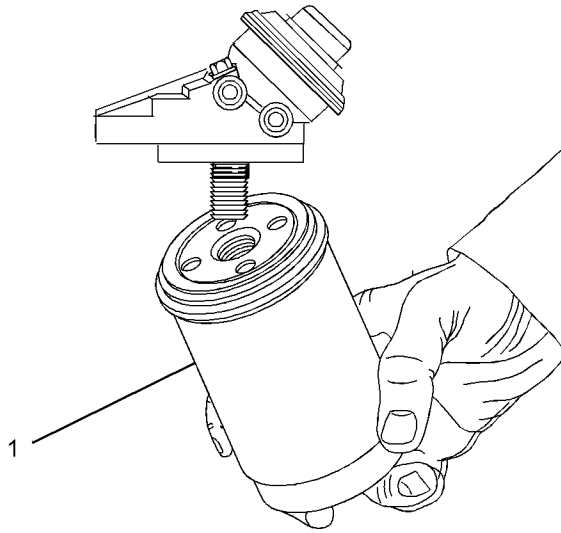

Illustration 68

g01306131

Typical example

3. By using a suitable tool, remove spin-on filter (1). Ensure that any fluid is drained into a suitable container.

**Note:** Do not fill the fuel filter with fuel. The fuel will not be filtered and the fuel could be contaminated. Contaminated fuel can damage your fuel system.

4. Install the new spin-on filter. Tighten the spin-on filter by hand.
5. Open the fuel supply valve.

The fuel system will need to be primed after the new filter is installed. Refer to this Operation and Maintenance Manual, "Fuel System - Prime" for the correct procedure.

## In Line Fuel Filter

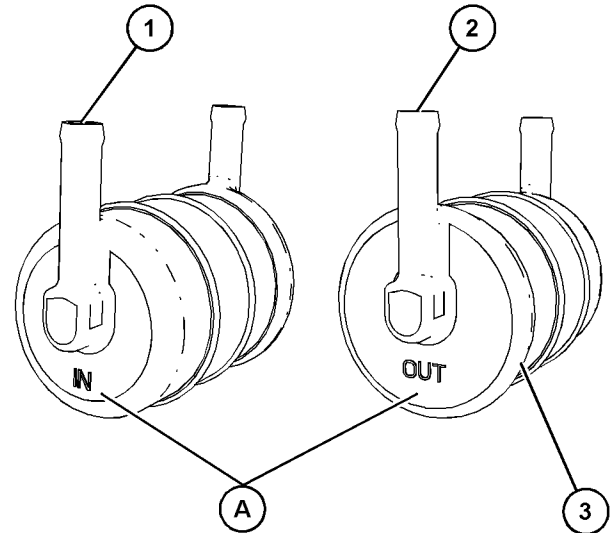

Illustration 69

g06524275

1. Close the fuel supply valve.
  2. Clean the outside of fuel filter (3) and the fuel hoses attached to the fuel filter.
  3. Make temporary identification marks on the fuel hoses to aid fuel filter installation. The direction of fuel flow through the fuel filter is identified in Position (A) on the fuel filter. Refer to illustration 69.
  4. Disconnect the fuel hoses from fuel inlet (1) and fuel outlet (2) of the fuel filter.
- Note:** Do not fill the fuel filter with fuel. The fuel will not be filtered and the fuel could be contaminated. Contaminated fuel can damage your fuel system.
5. Install the new fuel filter to the fuel hoses. Ensure that fuel inlet (1) and fuel outlet (2) are connected in the correct orientation.
  6. Secure the fuel hoses to fuel inlet (1) and fuel outlet (2) with hose clamps.
  7. Open the fuel supply valve.

The fuel system will need to be primed after the new filter is installed. Refer to this Operation and Maintenance Manual, "Fuel System - Prime" for the correct procedure.

i05337705

## Fuel System Primary Filter - Replace

### WARNING

Fuel leaked or spilled onto hot surfaces or electrical components can cause a fire. To help prevent possible injury, turn the start switch off when changing fuel filters or water separator elements. Clean up fuel spills immediately.

### NOTICE

Ensure that the engine is stopped before any servicing or repair is performed.

## Remove the Element

1. Turn the fuel supply valve (if equipped) to the OFF position before performing this maintenance.
2. Place a suitable container under the water separator in order to catch any fuel that might spill. Clean up any spilled fuel. Clean the outside body of the filter assembly.

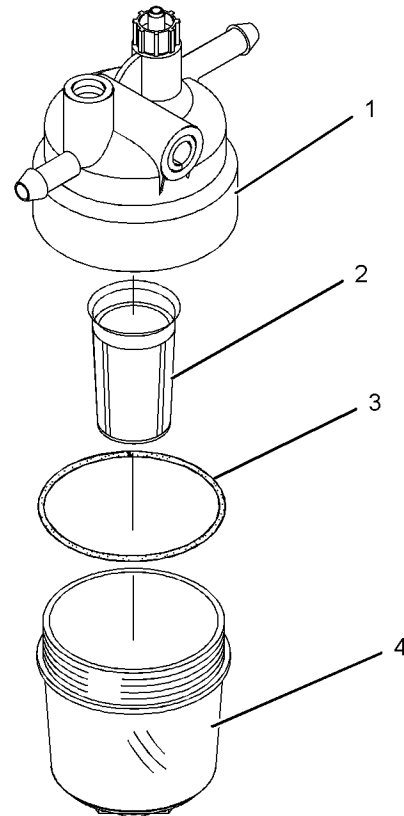

Illustration 70

g03381282

### Typical example

3. Remove the filter bowl (4) from the fuel filter base (1).
4. Remove the O-ring seal (3). Discard the O-ring seal.
5. Remove the filter element (2) from the fuel filter base (1). Discard the filter element (2).



6. Clean the filter bowl (4).

## Install the Element

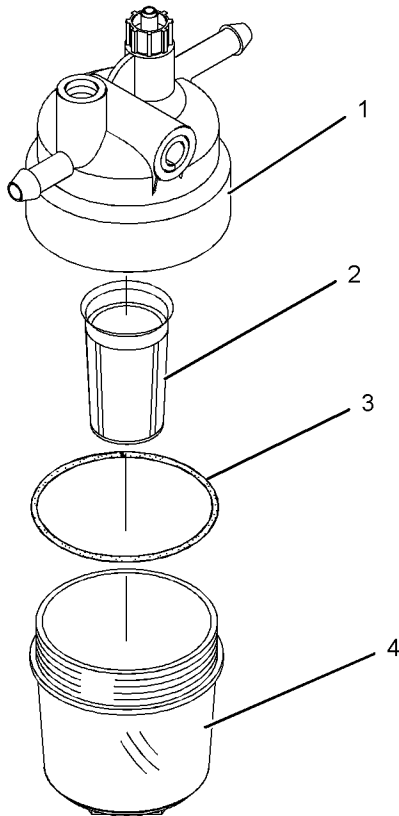

Illustration 71

g03381282

### Typical example

1. Install a new filter element (2) to the fuel filter base (1).
2. Lubricate the O ring seal (3) with clean engine oil. Do NOT fill the bowl with fuel before the assembly is installed.
3. Install the filter bowl (4) to the fuel filter base (1). Tighten the filter bowl (4) by hand.

4. The secondary fuel filter must be replaced at the same time as the primary fuel filter. Refer to the Operation and Maintenance Manual , “Fuel System Secondary Filter - Replace”.

i07023784

## Fuel System Primary Filter/ Water Separator - Drain

### **⚠ WARNING**

Fuel leaked or spilled onto hot surfaces or electrical components can cause a fire. To help prevent possible injury, turn the start switch off when changing fuel filters or water separator elements. Clean up fuel spills immediately.

### NOTICE

The water separator is under suction during normal engine operation. Ensure that the drain valve is tightened securely to help prevent air from entering the fuel system.

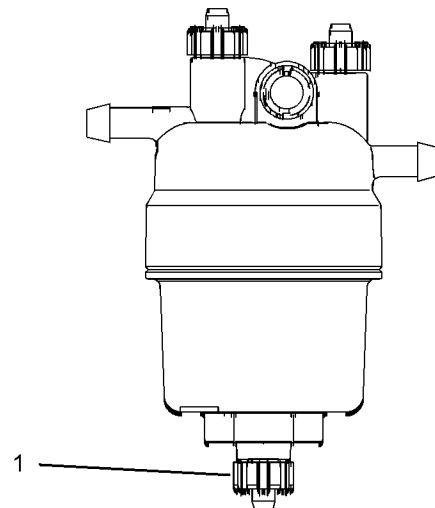

Illustration 72

g01316965

### Typical example

1. Open drain (1). Catch the draining fluid in a suitable container. Dispose of the drained fluid correctly.
2. Close drain (1).

i02335436

## Fuel Tank Water and Sediment - Drain

---

### NOTICE

Care must be taken to ensure that fluids are contained during performance of inspection, maintenance, testing, adjusting and repair of the product. Be prepared to collect the fluid with suitable containers before opening any compartment or disassembling any component containing fluids.

Dispose of all fluids according to local regulations and mandates.

---

### Fuel Tank

Fuel quality is critical to the performance and to the service life of the engine. Water in the fuel can cause excessive wear to the fuel system.

Water can be introduced into the fuel tank when the fuel tank is being filled.

Condensation occurs during the heating and cooling of fuel. The condensation occurs as the fuel passes through the fuel system and the fuel returns to the fuel tank. This causes water to accumulate in fuel tanks. Draining the fuel tank regularly and obtaining fuel from reliable sources can help to eliminate water in the fuel.

### Drain the Water and the Sediment

Fuel tanks should contain some provision for draining water and draining sediment from the bottom of the fuel tanks.

Open the drain valve on the bottom of the fuel tank in order to drain the water and the sediment. Close the drain valve.

Check the fuel daily. Allow five minutes after the fuel tank has been filled before draining water and sediment from the fuel tank.

Fill the fuel tank after operating the engine in order to drive out moist air. This will help prevent condensation. Do not fill the tank to the top. The fuel expands as the fuel gets warm. The tank may overflow.

Some fuel tanks use supply pipes that allow water and sediment to settle below the end of the fuel supply pipe. Some fuel tanks use supply lines that take fuel directly from the bottom of the tank. If the engine is equipped with this system, regular maintenance of the fuel system filter is important.

### Fuel Storage Tanks

Drain the water and the sediment from the fuel storage tank at the following intervals:

- Weekly
- Service intervals
- Refill of the tank

This will help prevent water or sediment from being pumped from the storage tank into the engine fuel tank.

If a bulk storage tank has been refilled or moved recently, allow adequate time for the sediment to settle before filling the engine fuel tank. Internal baffles in the bulk storage tank will also help trap sediment. Filtering fuel that is pumped from the storage tank helps to ensure the quality of the fuel. When possible, water separators should be used.

i02813964

### Hoses and Clamps - Inspect/Replace

Inspect all hoses for leaks that are caused by the following conditions:

- Cracking
- Softness
- Loose clamps

Replace hoses that are cracked or soft. Tighten any loose clamps.

---

### NOTICE

Do not bend or strike high pressure lines. Do not install bent or damaged lines, tubes or hoses. Repair any loose or damaged fuel and oil lines, tubes and hoses. Leaks can cause fires. Inspect all lines, tubes and hoses carefully. Tighten all connections to the recommended torque. Do not clip any other item to the high pressure lines.

---

Check for the following conditions:

- End fittings that are damaged or leaking
- Outer covering that is chafed or cut

- Exposed wire that is used for reinforcement
- Outer covering that is ballooning locally
- Flexible part of the hose that is kinked or crushed
- Armoring that is embedded in the outer covering

A constant torque hose clamp can be used in place of any standard hose clamp. Ensure that the constant torque hose clamp is the same size as the standard clamp.

Due to extreme temperature changes, the hose will harden. Hardening of the hoses will cause hose clamps to loosen. This can result in leaks. A constant torque hose clamp will help to prevent loose hose clamps.

Each installation application can be different. The differences depend on the following factors:

- Type of hose
- Type of fitting material
- Anticipated expansion and contraction of the hose
- Anticipated expansion and contraction of the fittings

## Replace the Hoses and the Clamps

Refer to the OEM information for further information on removing and replacing fuel hoses (if equipped).

The coolant system and the hoses for the coolant system are not usually supplied by Perkins. The following text describes a typical method of replacing coolant hoses. Refer to the OEM information for further information on the coolant system and the hoses for the coolant system.

### **WARNING**

**Pressurized System: Hot coolant can cause serious burns. To open the cooling system filler cap, stop the engine and wait until the cooling system components are cool. Loosen the cooling system pressure cap slowly in order to relieve the pressure.**

1. Stop the engine. Allow the engine to cool.
2. Loosen the cooling system filler cap slowly in order to relieve any pressure. Remove the cooling system filler cap.

**Note:** Drain the coolant into a suitable, clean container. The coolant can be reused.

3. Drain the coolant from the cooling system to a level that is below the hose that is being replaced.

4. Remove the hose clamps.
5. Disconnect the old hose.
6. Replace the old hose with a new hose.
7. Install the hose clamps with a torque wrench.

**Note:** For the correct coolant, see this Operation and Maintenance Manual, "Fluid Recommendations".

8. Refill the cooling system. Refer to the OEM information for further information on refilling the cooling system.
9. Clean the cooling system filler cap. Inspect the cooling system filler cap's seals. Replace the cooling system filler cap if the seals are damaged. Install the cooling system filler cap.
10. Start the engine. Inspect the cooling system for leaks.

i09650780

## Radiator - Clean

The radiator is not usually supplied by Perkins. The following text describes a typical cleaning procedure for the radiator. Refer to the OEM information for further information on cleaning the radiator.

**Note:** Adjust the frequency of cleaning according to the effects of the operating environment.

Inspect the radiator for these items: Damaged fins, corrosion, dirt, grease, insects, leaves, oil, and other debris. Clean the radiator, if necessary.

### **WARNING**

**Personal injury can result from air pressure.**

**Personal injury can result without following proper procedure. When using pressure air, wear a protective face shield and protective clothing.**

**Maximum air pressure at the nozzle must be less than 205 kPa (30 psi) for cleaning purposes.**

Pressurized air is the preferred method for removing loose debris. Direct the air in the opposite direction to the air flow of the fan. Hold the nozzle approximately 6 mm (0.25 inch) away from the radiator fins. Slowly move the air nozzle in a direction that is parallel with the radiator tube assembly, which will remove debris that is between the tubes.

Pressurized water may also be used for cleaning. The maximum water pressure for cleaning purposes must be less than 275 kPa (40 psi). Use pressurized water to soften mud. Clean the core from the front and rear.

Use a degreaser and steam for removal of oil and grease. Clean the core from the front and rear. Wash the core with detergent and hot water. Thoroughly rinse the core with clean water.

If the radiator is blocked internally, refer to the OEM Manual for information regarding flushing the cooling system.

After cleaning the radiator, start the engine. Allow the engine to operate at low idle speed for three to five minutes. Accelerate the engine to high idle. Accelerating the engine to high idle will help in the removal of debris and the drying of the core. Slowly reduce the engine speed to low idle and then stop the engine. Use a light bulb behind the core to inspect the core for cleanliness. Repeat the cleaning, if necessary.

Inspect the fins for damage. Bent fins may be opened with a "comb". Inspect these items for good condition: Welds, mounting brackets, air lines, connections, clamps, and seals. Make repairs, if necessary.

i02335775

## Severe Service Application - Check

Severe service is the application of an engine that exceeds the current published standards for that engine. Perkins maintains standards for the following engine parameters:

- Performance such as power range, speed range, and fuel consumption
- Fuel quality
- Operational Altitude
- Maintenance intervals
- Oil selection and maintenance
- Coolant type and maintenance
- Environmental qualities
- Installation
- The temperature of the fluid in the engine

Refer to the standards for the engine or consult your Perkins dealer or your Perkins distributor in order to determine if the engine is operating within the defined parameters.

Severe service operation can accelerate component wear. Engines that operate under severe conditions may need more frequent maintenance intervals in order to ensure maximum reliability and retention of full service life.

Due to individual applications, it is not possible to identify all of the factors which can contribute to severe service operation. Consult your Perkins dealer or your Perkins distributor for the unique maintenance that is necessary for the engine.

The operating environment, incorrect operating procedures and incorrect maintenance procedures can be factors which contribute to a severe service application.

## Environmental Factors

**Ambient temperatures** – The engine may be exposed to extended operation in extremely cold environments or hot environments. Valve components can be damaged by carbon buildup if the engine is frequently started and stopped in very cold temperatures. Extremely hot intake air reduces engine performance.

**Quality of the air** – The engine may be exposed to extended operation in an environment that is dirty or dusty, unless the equipment is cleaned regularly. Mud, dirt and dust can encase components. Maintenance can be very difficult. The buildup can contain corrosive chemicals.

**Buildup** – Compounds, elements, corrosive chemicals and salt can damage some components.

**Altitude** – Problems can arise when the engine is operated at altitudes that are higher than the intended settings for that application. Necessary adjustments should be made.

## Incorrect Operating Procedures

- Extended operation at low idle
- Frequent hot shutdowns
- Operating at excessive loads
- Operating at excessive speeds
- Operating outside the intended application

## Incorrect Maintenance Procedures

- Extending the maintenance intervals
- Failure to use recommended fuel, lubricants and coolant/antifreeze

i07888480

## Starting Motor - Inspect

Perkins recommends a scheduled inspection of the starting motor. If the starting motor fails, the engine may not start in an emergency situation.

Check the starting motor for correct operation. Check the electrical connections and clean the electrical connections. Refer to the Systems Operation, Testing and Adjusting Manual, "Electric Starting System - Test" for more information on the checking procedure and for specifications consult your Perkins dealer or your Perkins distributor for assistance.

i02184788

## Turbocharger - Inspect (If Equipped)

A regular visual inspection of the turbocharger is recommended. Any fumes from the crankcase are filtered through the air inlet system. Therefore, by-products from oil and from combustion can collect in the turbocharger compressor housing. Over time, this buildup can contribute to loss of engine power, increased black smoke and overall loss of engine efficiency.

If the turbocharger fails during engine operation, damage to the turbocharger compressor wheel and/or to the engine may occur. Damage to the turbocharger compressor wheel can cause additional damage to the pistons, the valves, and the cylinder head.

---

### NOTICE

Turbocharger bearing failures can cause large quantities of oil to enter the air intake and exhaust systems. Loss of engine lubricant can result in serious engine damage.

Minor leakage of oil into a turbocharger under extended low idle operation should not cause problems as long as a turbocharger bearing failure has not occurred.

When a turbocharger bearing failure is accompanied by a significant engine performance loss (exhaust smoke or engine rpm up at no load), do not continue engine operation until the turbocharger is renewed.

---

A visual inspection of the turbocharger can minimize unscheduled downtime. A visual inspection of the turbocharger can also reduce the chance for potential damage to other engine parts.

## Removal and Installation

**Note:** The turbochargers that are supplied are nonserviceable.

For options regarding the removal, installation, and replacement, consult your Perkins dealer or your Perkins distributor. Refer to the Disassembly and Assembly Manual, "Turbocharger - Remove and Turbocharger - Install" for further information.

## Inspecting

---

### NOTICE

The compressor housing for the turbocharger must not be removed from the turbocharger for cleaning.

The actuator linkage is connected to the compressor housing. If the actuator linkage is moved or disturbed the engine may not comply with emissions legislation.

---

1. Remove the pipe from the turbocharger exhaust outlet and remove the air intake pipe to the turbocharger. Visually inspect the piping for the presence of oil. Clean the interior of the pipes in order to prevent dirt from entering during reassembly.
2. Check for the presence of oil. If oil is leaking from the back side of the compressor wheel, there is a possibility of a failed turbocharger oil seal.  
  
The presence of oil may be the result of extended engine operation at low idle. The presence of oil may also be the result of a restriction of the line for the intake air (clogged air filters), which causes the turbocharger to slobber.
3. Inspect the bore of the housing of the turbine outlet for corrosion.
4. Fasten the air intake pipe and the exhaust outlet pipe to the turbocharger housing.

i02177973

## Walk-Around Inspection

### Inspect the Engine for Leaks and for Loose Connections

A walk-around inspection should only take a few minutes. When the time is taken to perform these checks, costly repairs and accidents can be avoided.

For maximum engine service life, make a thorough inspection of the engine compartment before starting the engine. Look for items such as oil leaks or coolant leaks, loose bolts, worn belts, loose connections and trash buildup. Make repairs, as needed:

Maintenance Section  
Water Pump - Inspect

---

- The guards must be in the correct place. Repair damaged guards or replace missing guards.
- Wipe all caps and plugs before the engine is serviced in order to reduce the chance of system contamination.

---

**NOTICE**

For any type of leak (coolant, lube, or fuel) clean up the fluid. If leaking is observed, find the source and correct the leak. If leaking is suspected, check the fluid levels more often than recommended until the leak is found or fixed, or until the suspicion of a leak is proved to be unwarranted.

---



---

**NOTICE**

Accumulated grease and/or oil on an engine is a fire hazard. Remove the accumulated grease and oil. Refer to this Operation and Maintenance Manual, "Engine - Clean" for more information.

---

- Ensure that the cooling system hoses are correctly clamped and that the cooling system hoses are tight. Check for leaks. Check the condition of all pipes.
- Inspect the water pump for coolant leaks.

**Note:** The water pump seal is lubricated by the coolant in the cooling system. It is normal for a small amount of leakage to occur as the engine cools down and the parts contract.

Excessive coolant leakage may indicate the need to replace the water pump seal. For the removal of the water pump and the installation of water pump and/or seal, refer to the Disassembly and Assembly Manual, "Water Pump - Remove and Install" for more information or consult your Perkins dealer or your Perkins distributor.

- Inspect the lubrication system for leaks at the front crankshaft seal, the rear crankshaft seal, the oil pan, the oil filters and the rocker cover.
- Inspect the fuel system for leaks. Look for loose fuel line clamps and/or tie-wraps.
- Inspect the piping for the air intake system and the elbows for cracks and for loose clamps. Ensure that hoses and tubes are not contacting other hoses, tubes, wiring harnesses, etc.
- Inspect the alternator belts and any accessory drive belts for cracks, breaks or other damage.

Belts for multiple groove pulleys must be replaced as matched sets. If only one belt is replaced, the belt will carry more load than the belts that are not replaced. The older belts are stretched. The additional load on the new belt could cause the belt to break.

- Drain the water and the sediment from the fuel tank on a daily basis in order to ensure that only clean fuel enters the fuel system.
- Inspect the wiring and the wiring harnesses for loose connections and for worn wires or frayed wires.
- Inspect the ground strap for a good connection and for good condition.
- Disconnect any battery chargers that are not protected against the current drain of the starting motor. Check the condition and the electrolyte level of the batteries, unless the engine is equipped with a maintenance free battery.
- Check the condition of the gauges. Replace any gauges that are cracked. Replace any gauge that can not be calibrated.

i01907756

## Water Pump - Inspect

A failed water pump may cause severe engine overheating problems that could result in the following conditions:

- Cracks in the cylinder head
- A piston seizure
- Other potential damage to the engine

**Note:** The water pump seal is lubricated by the coolant in the cooling system. It is normal for a small amount of leakage to occur as the engine cools down and parts contract.

Visually inspect the water pump for leaks. Renew the water pump seal or the water pump if there is an excessive leakage of coolant. Refer to the Disassembly and Assembly Manual, "Water Pump - Remove and Install" for the disassembly and assembly procedure.

## Warranty Section

## Warranty Information

i06590874

### Emissions Warranty Information

This engine may be certified to comply with exhaust emission and gaseous emission standards that are prescribed by the law at the time of manufacture. This engine may be covered by an Emissions Warranty. Consult your authorized Perkins dealer or distributor to determine if your engine is emissions certified and if your engine is subject to an Emissions Warranty.

# Index

## A

After Starting Engine .....	35
After Stopping Engine .....	37
Aftercooler Core - Clean/Test (Air-To-Air Aftercooler) .....	62
Aftercooler Core - Inspect .....	62
Alternator - Inspect .....	63
Alternator and Fan Belts - Inspect/Adjust .....	63
Adjustment .....	63
Inspection .....	63
Alternator and Fan Belts - Replace .....	64
Installation Procedure .....	64
Removal Procedure .....	64

## B

Battery - Replace .....	65
Battery Electrolyte Level - Check .....	65
Battery or Battery Cable - Disconnect .....	66
Before Starting Engine .....	13, 33
Burn Prevention .....	11
Batteries .....	11
Coolant .....	11
Diesel Fuel .....	11
Oils .....	11

## C

Cold Weather Operation .....	38
Hints for Cold Weather Operation .....	38
Idling the Engine .....	39
Recommendations for Coolant Warm Up .....	39
Recommendations for the Coolant .....	39
Viscosity of the Engine Lubrication Oil .....	39
Cooling System Coolant (Commercial Heavy-Duty) - Change .....	66
Drain .....	66
Fill .....	67
Flush .....	67
Cooling System Coolant (ELC) - Change .....	68
Drain .....	68
Fill .....	69
Flush .....	69
Cooling System Coolant Level - Check .....	70
Engines With a Coolant Recovery Tank .....	70
Engines Without a Coolant Recovery Tank .....	71
Cooling System Supplemental Coolant Additive (SCA) - Test/Add .....	71

Add the SCA, If Necessary .....	71
Test for SCA Concentration .....	71
Cooling System Water Temperature Regulator - Replace .....	72
Crushing Prevention and Cutting Prevention ..	13

## D

Driven Equipment - Check .....	72
--------------------------------	----

## E

Electrical System .....	14
Grounding Practices .....	15
Emergency Stopping .....	37
Emissions Certification Film .....	27
Emissions Warranty Information .....	95
Engine - Clean .....	73
Engine Air Cleaner Element - Replace .....	73
Servicing the Air Cleaner Elements .....	73
Engine Air Cleaner Service Indicator - Inspect .....	74
Test the Service Indicator .....	74
Engine Air Precleaner - Check/Clean .....	75
Engine Crankcase Breather - Replace .....	75
Engine Description .....	20
Aftermarket Products and Perkins Engines .....	25
Engine Specifications .....	20
Service Life .....	25
Engine Identification .....	26
Engine Lifting .....	28
Engine Only .....	29
Engines with Factory Installed Radiators .....	29
Engine Mounts - Inspect .....	76
Engine Oil and Filter - Change .....	76
Drain the Engine Oil .....	77
Fill the Engine Crankcase .....	78
Replace the Oil Filter .....	78
Engine Oil Level - Check .....	76
Engine Operation .....	36
Engine Starting .....	14, 33
Engine Stopping .....	14, 37
Engine Storage .....	29
Condition for Storage .....	29
Engine Valve Lash - Inspect/Adjust .....	79

## F

Features and Controls .....	32
-----------------------------	----



Fire Prevention and Explosion Prevention.....	11	<b>G</b>	
Ether .....	13	Gauges and Indicators .....	31
Fire Extinguisher.....	13	General Hazard Information.....	8
Lines, Tubes, and Hoses .....	13	Containing Fluid Spillage.....	9
Fluid Recommendations .....	55	Fluid Penetration .....	9
Engine Oil .....	55	Inhalation .....	9
General Lubricant Information.....	55	Pressure Air and Water .....	8
Fluid Recommendations (Coolant		Static Electricity Hazard when Fueling with	
Specifications).....	51	Ultra-low Sulfur Diesel Fuel .....	9
ELC Cooling System Maintenance.....	53		
General Coolant Information .....	51	<b>H</b>	
Fluid Recommendations (Fuel		Hoses and Clamps - Inspect/Replace.....	90
Specification).....	44	Replace the Hoses and the Clamps .....	91
Diesel Fuel Characteristics.....	46		
Diesel Fuel Requirements .....	45	<b>I</b>	
General Information.....	44	Important Safety Information.....	2
Foreword .....	4		
California Proposition 65 Warning.....	4	<b>L</b>	
Literature Information .....	4	Lifting and Storage .....	28
Maintenance .....	4		
Maintenance Intervals .....	5	<b>M</b>	
Operation .....	4	Maintenance Interval Schedule.....	61
Overhaul .....	5	Daily .....	61
Safety.....	4	Every 1000 Service Hours.....	61
Fuel and the Effect from Cold Weather.....	40	Every 2000 Service Hours.....	61
Fuel Conservation Practices .....	36	Every 250 Service Hours or 6 Months.....	61
Fuel Injector - Test/Change.....	79	Every 3000 Service Hours.....	61
Identification of a suspect Fuel Injector .....	80	Every 3000 Service Hours or 2 Years .....	61
Fuel Related Components in Cold Weather ...	41	Every 4000 Service Hours.....	61
Fuel Filters .....	41	Every 50 Service Hours or Weekly .....	61
Fuel Heaters .....	41	Every 500 Service Hours or 1 Year .....	61
Fuel Tanks .....	41	Every 6000 Service Hours or 3 Years .....	61
Fuel Shutoff .....	32	When Required.....	61
Fuel System - Prime .....	80	Maintenance Recommendations .....	59
Fuel filters .....	81	Maintenance Section.....	42
Primary filter.....	80	Model View Illustrations .....	16
Priming the system .....	82	Engines with Factory Installed Radiators ....	20
Fuel System Filter - Replace.....	85	Model Views .....	16
Fuel Filter with Canister.....	85		
Fuel Filter with Element .....	86	<b>O</b>	
Fuel Filter with Priming Pump.....	86	Operation Section.....	28
In Line Fuel Filter .....	87		
Fuel System Primary Filter - Replace .....	88	<b>P</b>	
Install the Element .....	89	Product Identification Information .....	26
Remove the Element .....	88	Product Information Section.....	16
Fuel System Primary Filter/Water			
Separator - Drain .....	89		
Fuel Tank Water and Sediment - Drain .....	90		
Drain the Water and the Sediment .....	90		
Fuel Storage Tanks.....	90		
Fuel Tank .....	90		

**R**

Radiator - Clean .....	91
Reference Numbers .....	26
Record for Reference .....	26
Refill Capacities .....	42
Cooling System.....	43
Lubrication System .....	42

**S**

Safety Messages .....	6
(A) Universal Warning.....	6
Safety Section .....	6
Serial Number Plate .....	26
Severe Service Application - Check.....	92
Environmental Factors.....	92
Incorrect Maintenance Procedures .....	92
Incorrect Operating Procedures .....	92
Starting Motor - Inspect.....	92
Starting the Engine.....	34
Starting with Jump Start Cables .....	35
Stopping the Engine .....	37
System Pressure Release.....	59
Coolant System .....	59
Engine Oil .....	59
Fuel System.....	59

**T**

Table of Contents .....	3
Turbocharger - Inspect (If Equipped) .....	93
Inspecting .....	93
Removal and Installation .....	93

**W**

Walk-Around Inspection .....	93
Inspect the Engine for Leaks and for Loose Connections .....	93
Warranty Information.....	95
Warranty Section.....	95
Water Pump - Inspect.....	94
Welding on Engines with Electronic Controls .....	59

# Product and Dealer Information

Note: For product identification plate locations, see the section "Product Identification Information" in the Operation and Maintenance Manual.

Delivery Date: \_\_\_\_\_

## Product Information

Model: \_\_\_\_\_

Product Identification Number: \_\_\_\_\_

Engine Serial Number: \_\_\_\_\_

Transmission Serial Number: \_\_\_\_\_

Generator Serial Number: \_\_\_\_\_

Attachment Serial Numbers: \_\_\_\_\_

Attachment Information: \_\_\_\_\_

Customer Equipment Number: \_\_\_\_\_

Dealer Equipment Number: \_\_\_\_\_

## Dealer Information

Name: \_\_\_\_\_ Branch: \_\_\_\_\_

Address: \_\_\_\_\_

\_\_\_\_\_

\_\_\_\_\_

Dealer Contact

Phone Number

Hours

Sales: \_\_\_\_\_

Parts: \_\_\_\_\_

Service: \_\_\_\_\_

SEBU8311  
©2023 Perkins Engines Company Limited  
All Rights Reserved