

# 140/150/160

## Motor Graders



	140/140 AWD		150/150 AWD		160/160 AWD	
Engine Model	Cat® C9.3		Cat C9.3		Cat C9.3	
Base Power (1st gear) – Net	133 kW	179 hp	149 kW	200 hp	165 kW	221 hp
Base Power (1st gear) – Net (Metric)		181 hp		202 hp		224 hp
VHP Plus Range – Net	133-172 kW	179-231 hp	149-188 kW	200-252 hp	165-203 kW	221-272 hp
VHP Plus Range – Net (Metric)		181-234 hp		202-255 hp		224-276 hp
AWD Range – Net	141-188 kW	189-252 hp	156-203 kW	210-272 hp	172-219 kW	231-293 hp
AWD Range – Net (Metric)		192-255 hp		213-276 hp		234-298 hp
Moldboard – Blade Width	3.7 m	12 ft	3.7 m	12 ft	4.2 m	14 ft
Operating Weight, Typically Equipped	19 344 kg	42,647 lb	19 935 kg	43,950 lb	20 660 kg	45,547 lb
Operating Weight, Typically Equipped AWD	20 236 kg	44,614 lb	20 827 kg	45,917 lb	21 552 kg	47,514 lb

## Features

### Emissions Reduction

*Cat emissions reduction technology is designed to be transparent to the operator and meets U.S. EPA Tier 4 Final/EU Stage V standards.*

### Operator Comfort

*Industry leading cab and intuitive joystick controls give you unmatched comfort and visibility. New seat offers you heated/ventilated options.*

### Ease of Service

*Drawbar-Circle-Moldboard features make it easy to maintain factory tightness for better grading results. New engine enclosure lights make service more convenient in low light.*

### Efficient Performance

*New Economy Mode helps you save fuel – up to 10 percent.*

### Integrated Technologies

*Cat technologies makes smart use of technology and services to help you monitor, manage and enhance job site operations.*

### Safety

*Features like Operator Not Present monitoring, hydraulic lockout and redundant steering and braking systems help you meet your safety goals.*

## Contents

Operator Station.....	4
Machine and Implement Controls.....	5
Engine .....	6
Emissions Technology.....	7
Powertrain.....	8
Structures and Drawbar-Circle-Moldboard....	9
Hydraulics .....	10
All Wheel Drive (AWD).....	11
Integrated Technologies.....	12
Safety .....	14
Work Tools and Attachments.....	16
Smart Machine Systems.....	17
Serviceability and Customer Support.....	17
Sustainability .....	18
Specifications.....	19
Standard Equipment.....	33
Optional Equipment.....	34
Environmental Declaration.....	35





**The 140/150/160 Motor Graders bring the latest emissions reduction technology to the most durable, productive and comfortable motor graders on the market. From building roads to maintaining them, motor graders are designed to help you get more work done in less time. Outstanding durability, unprecedented operator comfort and ease of service help to maximize your return on investment. The 140/150/160 Motor Graders meet U.S. EPA Tier 4 Final/EU Stage V standards.**

# Operator Station

Comfort, productivity, advanced technology



## Visibility

Good visibility is key to your safety and efficiency. Angled cab doors, tapered engine enclosure and a sloped rear window make it easy to see the moldboard and tires, as well as behind the machine. An optional rear vision camera further enhances lines of sight all around the machine.

## In-Dash Instrument Cluster

A redesigned message display shows machine performance and diagnostic information, including DEF tank levels. Now located in the center console, it also displays Cat Grade Control Cross Slope readings conveniently in front of the operator.

## Comfort and Control

Experience the most comfortable cab in the industry. Joystick controls replace levers, so hand and arm movement is reduced by 78%, helping reduce operator fatigue for better productivity. Rocker and control switches are in easy reach.

An updated seat with softer cushions and three-position cushion tilt adds to your overall comfort. You can even upgrade to a heated or heated/ventilated seat. An optional seat belt indicator feature is also available. Control pods can be adjusted electronically, making it easy to set your ideal operating position. Multiple isolation mounts significantly reduce sound and vibration for a more relaxed work environment.

The high capacity Heating, Ventilation and Air Conditioning (HVAC) system dehumidifies and pressurizes the cab, seals out dust and helps keep windows clear. Pop-out louvers circulate fresh air. An optional deluxe radio with CD features MP3 and Bluetooth technology.



# Machine and Implement Controls

Unprecedented precision and ease of operation



Two electro-hydraulic joysticks with electronically adjustable control pods help position operators for optimal comfort, visibility and productive operation.

## Joystick Functions

The left joystick controls machine direction, steering, articulation, return-to-center, wheel lean, gear selection, left moldboard lift cylinder and float.

The right joystick controls drawbar, circle and moldboard functions as well as electronic throttle control and manual differential lock/unlock.

The steer tire angle matches the joystick position. A brake tensioning system holds the joystick in position until the operator moves it. The steering control automatically reduces steering sensitivity at higher ground speeds for predictable control.

Infinitely variable roller switches control the rear ripper and/or front lift group (when equipped). Optional Programmable Auxiliary Hydraulic Pod controls up to six additional hydraulic circuits.

## Electronic Throttle Control

Electronic Throttle Control helps improve productivity by providing the best match of horsepower and torque for the demands of the application.

## Articulation Return-to-Center

Automatically returns the machine to a straight frame position from any angle with the touch of a button.

## Selectable Blade Lift Modes

Choose the blade lift modulation mode that best fits your application or operating style: Fine, Normal, or Coarse.



# Engine

Power and reliability



A Cat C9.3 engine gives you the performance you need to maintain consistent grading speeds for maximum productivity. Every U.S. EPA Tier 4 Final/EU Stage V engine is equipped with a combination of proven electronic, fuel, air and aftertreatment components. Applying proven technologies systematically and strategically helps meet your high expectations for productivity, fuel efficiency, reliability and service life.

## Hydraulic Demand Fan

The hydraulic demand fan automatically adjusts speed according to cooling requirements. When cooling demand is reduced, you benefit from more power to the ground and improved fuel efficiency.

## Engine Idle Shutdown Timer

This standard feature can be software-enabled by your Cat dealer to shut down the engine after a set period of time to save you fuel and help reduce emissions.



# Emissions Technology

Proven, integrated solutions



Emissions reduction technology on the 140/150/160 Motor Graders is designed to be transparent, with no action required from the operator. There is no need to stop. Regeneration runs automatically at cold start-up and, if needed, in the background while you work.

## Aftertreatment Technologies

Caterpillar designed Tier 4 Interim products with Tier 4 Final standards in mind. To meet the additional 80 percent reduction in NOx emissions required by EPA Tier 4 Final/EU Stage V emission standards, Caterpillar engineers only needed to add one new system to the already proven aftertreatment solution in use, Selective Catalytic Reduction (SCR).

## Diesel Exhaust Fluid

Selective Catalytic Reduction utilizes Diesel Exhaust Fluid (DEF), which can be conveniently filled from ground level. Simply refill the DEF tank when you refuel. A gauge on the dash shows your fluid level.

When you turn the machine off, a pump will automatically purge the DEF lines. A light located inside the rear engine compartment will turn off, telling you the purge is complete and that it is safe to turn off the electrical disconnect. If the engine/aftertreatment temperatures are high, a Delayed Engine Shutdown will activate automatically to cool the machine and then purge the lines.

For complete aftertreatment information, please refer to your machine's Operation and Maintenance Manual.



# Powertrain

## Maximum power to the ground

- Standard Automatic Differential Lock/Unlock monitors machine and application parameters to unlock/re-lock the differential during operation, improving production and enhancing comfort while protecting the powertrain.
- Full Electronic Clutch Pressure Control optimizes inching modulation for smooth shifts and directional changes.
- Programmable Autoshift option simplifies operation by allowing you to program the transmission to shift at optimal points to match your application.
- New standard Economy Mode can be turned on to help save fuel by reducing engine speed so the machine works in a more efficient range. The average fuel savings is up to 10 percent, depending on the application.
- Power Shift Countershaft Transmission maximizes power to the ground.
- Engine Over-Speed Protection prevents downshifting until an acceptable safe travel speed has been established.

### Front and Rear Axles

The sealed spindle keeps front axle bearings lubricated and protected from contaminants. The Cat “Live Spindle” design places the larger tapered roller bearing on the outside, where the load is greater, extending bearing life. A bolt-on modular rear axle improves serviceability and contamination control with easy access to differential components.

### Hydraulic Brakes

Oil-bathed multi-disc service brakes are hydraulically actuated for smooth, predictable braking and lower operating costs. Brakes are located at each tandem wheel and have a large total brake surface area to give you dependable stopping power and longer life.

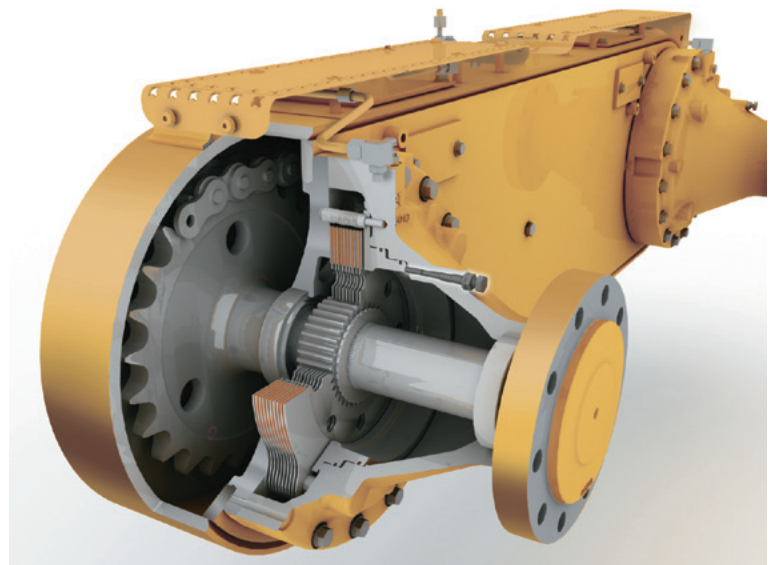
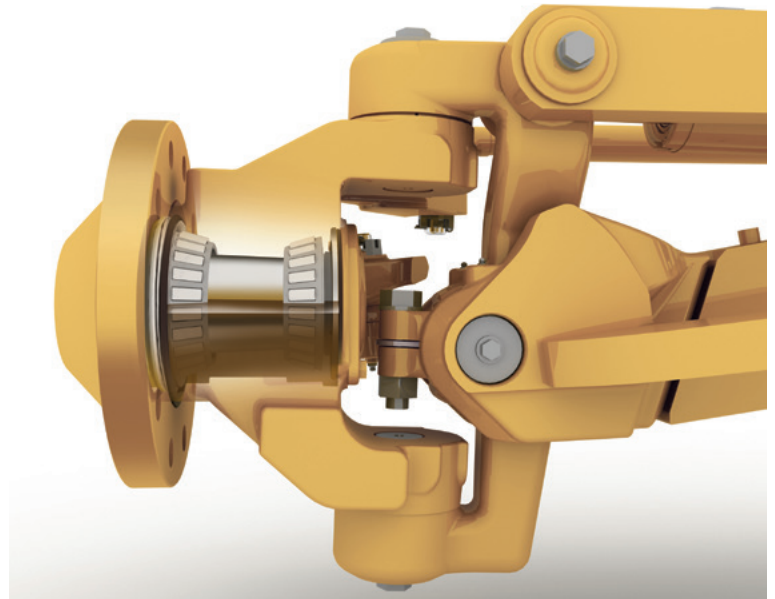
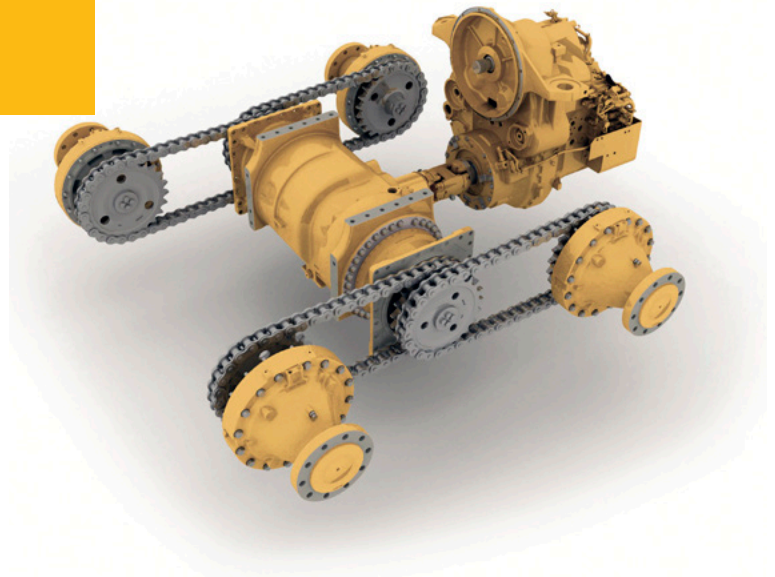



# Structures and Drawbar-Circle-Moldboard

## Service ease and precise blade control



Caterpillar designs motor grader frame and drawbar components to give you performance and durability. The one-piece forged steel circle stands up to high stress loads, and a sacrificial wear system helps keep your service time and costs down.

The articulation hitch features a large tapered roller bearing to carry loads evenly and smoothly. It is sealed to prevent contamination and a locking pin prevents articulation for safety during service or transport.

### Easy Maintenance for More Uptime

The drawbar, circle and moldboard are designed to make it easy to keep the components tight. One person can easily adjust or replace the patented top-adjust drawbar wear inserts from the top of the drawbar plate, reducing downtime to save you money. Durable nylon composite wear inserts maximize circle torque and component life. Sacrificial brass wears strips between the blade mounting group and moldboard can be easily adjusted and replaced. The Shimless Moldboard Retention System uses vertical and horizontal adjusting screws to keep moldboard wear strips aligned for reduced blade chatter and precise blade control.

### Blade Angle and Moldboard

An aggressive blade angle, optimized moldboard curvature and large throat clearance help you work more efficiently by allowing material to roll more freely along the blade.

Heat-treated rails, hardened cutting edges and end bits, and heavy duty bolts to give you greater moldboard reliability and long service life. The link bar allows extreme moldboard positioning for easier bank sloping and ditch cutting/cleaning.

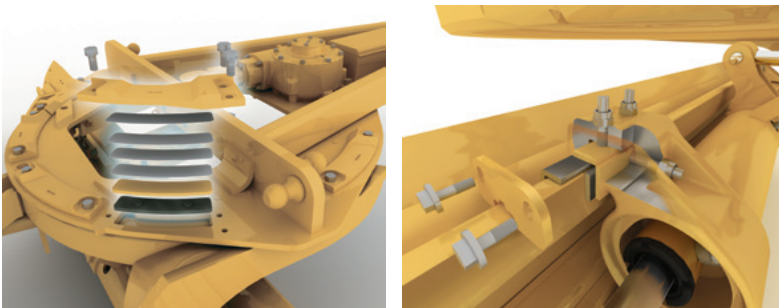

# Hydraulics

## Advanced machine control



### Responsive Hydraulics

A proven load-sensing system and advanced electro-hydraulics give you superior implement control and responsive hydraulic performance that helps make your operator's job easier. Continuously matching hydraulic flow/pressure to power demands creates less heat and reduces power consumption.

- Consistent, Predictable Movement – Proportional Priority Pressure-Compensating (PPP-C) valves have different flow rates for the head and rod ends of the cylinder, so you can count on consistent, predictable implement response.
- Balanced Flow – Hydraulic flow is proportioned to give you confidence that all implements will operate simultaneously without slowing the engine or speed of some implements.

### Blade Float

Allows the blade to move freely under its own weight. By floating both cylinders, the blade can follow the contours of the ground. Floating only one cylinder permits the toe of the blade to follow a hard surface while the operator controls the slope with the other lift cylinder.

### Independent Oil Supply

Large, separate hydraulic oil supplies prevent cross-contamination and provide proper oil cooling, which reduces heat build-up and extends component life. Cat XT™ hose allows high pressures for maximum power and reduced downtime.



# All Wheel Drive (AWD)

Expanded machine versatility



■ Without Steering Compensation   ■ With Steering Compensation

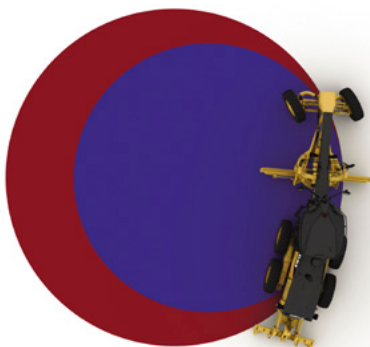

If you work in soft underfoot conditions where traction can be a challenge, optional All Wheel Drive (AWD) can give you the additional power to the ground you need to work more efficiently in mud, gravel, sand or snow. The added traction helps reduce sliding on side slopes.

- Dedicated left and right pumps give you more precise hydraulic control. The infinitely variable pumps and motors maximize torque in each gear.
- AWD automatically increases horsepower to maximize your power to the ground.
- Standard Hydrostatic Mode disengages the transmission and provides hydraulic power to the front wheels only. Infinitely variable ground speed between 0-8 km/h (0-5 mph) is ideal for precise finish work.
- Cat Steering Compensation System enables a “powered turn” by adjusting the outside front tire speed up to 50% faster than the inside tire. This gives you improved control, reduces surface damage and greatly reduces turning radius in poor underfoot conditions.

# Integrated Technologies

Monitor, manage, and enhance job site operations



Cat Equipment Management makes smart use of technology and services to improve your jobsite efficiency. Using the data from technology-equipped machines, you'll get more information and insight into your equipment and operations than ever before.

Cat technologies offer improvements in these key areas:



**Equipment Management** – increase uptime and reduce operating costs.



**Productivity** – monitor production and manage job site efficiency



**Safety** – enhance job site awareness to keep your people and equipment safe.

VisionLink® takes the guesswork out of managing your entire fleet –regardless of size or equipment manufacturer.\* Review equipment data from your desktop or mobile device to maximize uptime and optimize assets. With interactive dashboards, VisionLink makes it easier for operations of all sizes to make informed decisions that lower costs, simplify maintenance, and improve safety and security on your jobsite. With different subscription-level options, your Cat dealer can help you determine what you need to connect your fleet and manage your business.

*\*Data field availability can vary by equipment manufacturer.*

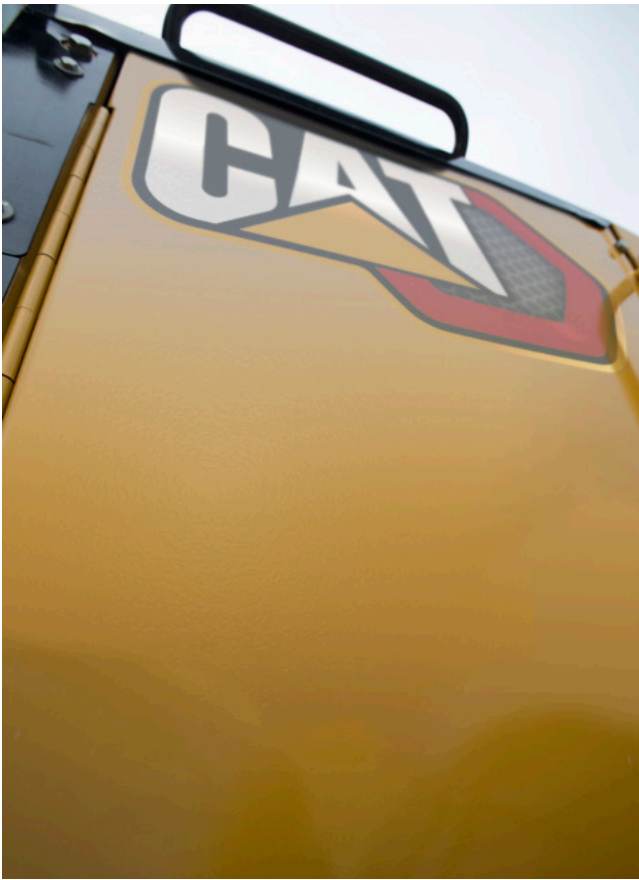

## Grade

Grade technologies combine digital design data, in-cab guidance, and automatic blade controls to enhance grading accuracy, reduce rework, and lower costs related to production earthmoving and rough, fine and finish grade applications.

## Cat Grade with Cross Slope

Cat Grade with Cross Slope is an optional fully integrated, factory installed system that helps your operator improve grading efficiency and more easily maintain accurate cross slopes. The system automatically controls one side of the blade, reducing manual operator inputs by as much as 50 percent. Experienced operators can maintain peak efficiency levels throughout more of the work day, while less experienced operators can be more productive faster. The system is job-ready from day one, and scalable for the future with upgrade kits that provide additional 2D and/or 3D control.

## Cat Grade with 3D

Cat Grade with 3D for motor graders is a machine integrated grade control system that helps you get to grade faster with more accuracy, efficiency and productivity. Automatic blade control reduces operator inputs and the number of passes to get the job done to save you time and money. All Cat Grade systems are compatible with radios and base stations from Trimble, Topcon, and Leica. Already invested in a grade infrastructure? You can install grade systems from Trimble, Topcon, and Leica onto the machine.

## Additional Options

Cat Grade Attachment Ready Option (ARO) integrates easily with Cat Grade and other grade control systems to help you get the most out of your motor grader. Stable Blade helps improve your finished surface quality by reducing machine bounce.

View blade slope on the integrated machine display with the Digital Blade Slope Meter.

Cat Grade with Cross Slope Indicate shows cross slope information on the integrated machine display. Cross Slope Indicate improves grading efficiency by providing real-time cross slope to you without the added expense of equipment to automate blade functions.



# Safety

Designed with protection in mind



## Safety Features

- Optional rearview camera with in-cab monitor
- New optional seat belt indicator light reminds operator to fasten safety belt
- Grouped, ground level service points
- Laminated front window glass
- Optional LED Lighting
- Ground-level electrical disconnect switch
- Ground-level engine shutoff switch
- Anti-glare paint eases night operation
- Optional front and rear fenders

### Operator Presence Monitoring System

Standard system keeps the parking brake engaged and hydraulic implements disabled until the operator is seated and the machine is ready for operation.

### Speed Sensitive Steering

Standard function makes steering less sensitive as ground speed increases for greater operator confidence and control.

### Secondary Steering System

Standard feature automatically engages an electric hydraulic pump in case of a drop in steering pressure so the operator can steer the machine to a stop.

### Hydraulic Lockout

Disables all implement functions while still providing machine steering control. This standard safety feature is especially useful while roading.

### Brake Systems

Brakes are located at each tandem wheel to eliminate braking loads on the powertrain. Redundant brake systems utilize accumulators to enable stopping in case of machine failure.

### Walkways and Grab Rails

Perforated steel tandem walkways and convenient grab rails give you a sturdy platform when moving on, off and around the machine.

### Circle Drive Slip Clutch

Protects the drawbar, circle and moldboard from shock loads when the blade encounters an immovable object. This standard feature also reduces the possibility of abrupt directional changes in poor traction conditions.

### Blade Lift Accumulators

Help absorb impact loads to the moldboard by allowing vertical blade travel. This optional feature helps reduce wear and aids operator safety.



# Work Tools and Attachments

Equip your machine for the job



## Moldboard Options

The 140, 150, and 160 motor graders come equipped with a 3.7 m (12 ft) moldboard. An optional 4.3 m (14 ft) blade is available for all models, as well as a 4.9 m (16 ft) moldboard for the 160.

## Ground Engaging Tools (GET)

A variety of tools are available from Cat Work Tools, including cutting edges, graderbits and end bits, all designed for maximum service life and productivity.

## Front Mounted Groups

A front mounted push plate or front lift group are available. The front lift group can be combined with a front dozer blade or front scarifier for added versatility.

## Rear Ripper/Scarifier

Made to penetrate tough material fast and rip thoroughly for easier movement with the moldboard. The ripper includes three shanks (with holders for five). Nine scarifier shanks can also be added for additional versatility.

## Snow Removal Work Tools

Snow plow, snow wing and mounting options increase machine versatility and utilization throughout the year.





# Smart Machine Systems

## Advanced Diagnostics

- Cat Messenger, combined with full systems integration, enhances diagnostic capability for quick analysis of critical data.
- Electronic Technician (Cat ET) lets service technicians access stored diagnostic data and configure machine parameters through the Cat Data Link.
- Low Battery Elevated Idle raises idle speed when low system voltage is detected, ensuring adequate system voltage and improving battery reliability.
- Automatic Engine Deration protects the engine by automatically lowering engine torque output and alerting the operator if critical conditions are detected.



## Serviceability and Customer Support

When uptime counts

Cat motor graders are designed to help you increase uptime and reduce costs. Grouped service points and extended service intervals save maintenance time. New optional LED lights in the left hand compartment makes it more convenient to service the machine in low light.

### Unparalleled Dealer Support

When it comes to supporting you, Cat dealers are second to none. From machine selection and purchase to maintenance support and rebuilds, Cat dealers have the experience and capabilities to help keep you up and running.



# Sustainability

Thinking generations ahead



## Fuel Efficiency

- Integrated machine systems and technologies improve productivity for greater accuracy, allowing the machine to do more work per gallon of fuel.
- New Economy Mode feature allows the machine to work in the most efficient engine speed range to help reduce fuel use.

## Green House Gas Emissions

- Reduced fuel consumption means reduced CO<sub>2</sub> emissions.

## Material Efficiency and Lifecycle Costs

- Replaceable wear parts save maintenance time and cost, and extend major component life.
- Major components are built to be rebuilt, eliminating waste and saving customers money by giving the machine and/or major components a second – and even third – life.
- Approximately 95% of machine materials can be recycled (ISO 16714) to conserve valuable natural resources and further enhance machine end-of-life value.

## Sound

- Reduced engine noise and quieter cabs mean lower operator and spectator sound levels.

## Safety

- Ecology drains help make draining fluids more convenient and help prevent spills.
- Cartridge style hydraulic fluid filters provide safe clean draining of filters prior to replacement, helping to prevent fluid spills.
- A variety of safety features help safeguard operators and others on the job site.

# 140/140 AWD Motor Graders Specifications

## Engine

Engine Model	Cat C9.3		
Emissions	U.S. EPA Tier 4 Final/ EU Stage V		
Base Power (1st gear) – Net	133 kW	179 hp	
Base Power (1st gear) – Net (Metric)	181 hp		
VHP Plus Range – Net	133-172 kW	179-231 hp	
VHP Plus Range – Net (Metric)	181-234 hp		
AWD Range – Net	141-188 kW	189-252 hp	
AWD Range – Net (Metric)	192-255 hp		
Displacement	9.3 L	567.5 in <sup>3</sup>	
Bore	115 mm	4.5 in	
Stroke	149 mm	5.9 in	
Torque Rise	38%		
Maximum Torque (VHP Plus)	1138 N·m	840 lb-ft	
Maximum Torque (AWD On)	1247 N·m	920 lb-ft	
Speed @ Rated Power	2,000 rpm		
Number of Cylinders	6		
Derating Altitude	3050 m	10,000 ft	
High Ambient – Fan Speed			
Standard	1,400 rpm		
Maximum	1,550 rpm		
Minimum	500 rpm		
Standard Capability	43° C	109° F	
High Ambient Capability	50° C	122° F	
	<b>VHP Plus</b>	<b>AWD Off</b>	<b>AWD On</b>
	<b>kW (hp)</b>	<b>kW (hp)</b>	<b>kW (hp)</b>
Gear – Net Power			
Forward			
1st	133 (179)	141 (189)	149 (200)
2nd	141 (189)	149 (200)	164 (220)
3rd	149 (200)	156 (210)	168 (225)
4th	156 (210)	160 (215)	172 (231)
5th	160 (215)	164 (220)	188 (252)
6th	164 (220)	168 (225)	188 (252)
7th	168 (225)	172 (231)	188 (252)
8th	172 (231)	172 (231)	188 (252)
Reverse			
1st	133 (179)	133 (179)	133 (179)
2nd	141 (189)	141 (189)	141 (189)
3rd–6th	149 (200)	149 (200)	149 (200)

## Engine (cont'd)

- Net power is tested per ISO 9249, SAE J1349, and EEC 80/1269 Standards in effect at the time of manufacture.
  - VHP Plus is standard for the 140 and 140 AWD.
  - Net power advertised is the power available at rated speed of 2,000 rpm, measured at the flywheel when engine is equipped with fan running at minimum speed, air cleaner, muffler and alternator.
  - No engine derating required up to 3050 m (10,000 ft).
  - Power as declared per ISO 14396  
Rated rpm 2,000  
VHP+ = 173 kW (232 hp)  
AWD = 189 kW (253 hp)
  - Cat engines equipped with a Selective Catalytic Reduction (SCR) system are required to use:
    - Diesel Exhaust Fluid (DEF) which meets the requirements outlined in the International Organization for Standardization (ISO) standard 22241-1.
  - Cat diesel engines are required to use ULSD (ultra-low sulfur diesel fuel with 15 ppm of sulfur or less) or ULSD blended with the following lower-carbon intensity fuels\*\* up to:
    - ✓ 20% biodiesel FAME (fatty acid methyl ester)\*
    - ✓ 100% renewable diesel, HVO (hydrotreated vegetable oil) and GTL (gas-to-liquid) fuels
- Refer to guidelines for successful application. Please consult your Cat dealer or “Caterpillar Machine Fluids Recommendations” (SEBU6250) for details.
- \*Engines with no aftertreatment devices can use higher blends, up to 100% biodiesel (for use of blends higher than 20% biodiesel, consult your Cat dealer).
- \*\*Tailpipe greenhouse gas emissions from lower-carbon intensity fuels are essentially the same as traditional fuels.

## Powertrain

Forward/Reverse Gears	8 Forward/6 Reverse
Transmission	APECS, Direct Drive, Powershift
Brakes	
Service	Multiple Oil Disc
Service, Surface Area	23 000 cm <sup>2</sup> 3,565 in <sup>2</sup>
Parking	Multiple Oil Disc
Secondary	Dual Circuit

## Hydraulic System

Circuit Type	Parallel
Pump Type	Variable Piston
Pump Output	210 L/min    55.7 gal/min
Maximum System Pressure	24 150 kPa    3,500 psi
Reservoir Tank Capacity	64.0 L    16.9 gal
Standby Pressure	6100 kPa    885 psi

- Pump output measured at 2,150 rpm.

# 140/140 AWD Motor Graders Specifications

## Operating Specifications

Top Speed		
Forward	46.6 km/h	29.0 mph
Reverse	36.8 km/h	23.0 mph
Turning Radius, Outside Front Tires		
	7.8 m	25 ft 7 in
Steering Range – Left/Right		
	50°	
Articulation Angle – Left/Right		
	20°	
Forward		
1st	4.1 km/h	2.5 mph
2nd	5.5 km/h	3.4 mph
3rd	8.0 km/h	5.0 mph
4th	11.0 km/h	6.9 mph
5th	17.1 km/h	10.6 mph
6th	23.3 km/h	14.5 mph
7th	32.0 km/h	19.9 mph
8th	46.6 km/h	29.0 mph
Reverse		
1st	3.2 km/h	2.0 mph
2nd	6.0 km/h	3.7 mph
3rd	8.7 km/h	5.4 mph
4th	13.5 km/h	8.4 mph
5th	25.3 km/h	15.7 mph
6th	36.8 km/h	23.0 mph

• Calculated with no slip and 14.0R24 tires.

## Service Refill

Fuel Capacity	394 L	104 gal
Cooling System	57.0 L	15.0 gal
Hydraulic System		
Total	100 L	26.4 gal
Tank	64.0 L	16.9 gal
Engine Oil	30.0 L	7.9 gal
Trans./Diff./Final Drives	70.0 L	18.5 gal
Tandem Housing (Each)	76.0 L	20.0 gal
Front Wheel Spindle Bearing Housing	0.5 L	0.13 gal
Circle Drive Housing	7.0 L	1.8 gal
Diesel Exhaust Fluid	22.0 L	5.8 gal

## Frame

Circle		
Diameter	1530 mm	60.2 in
Height	138 mm	5.4 in
Blade Beam Thickness	40.0 mm	1.6 in
Drawbar		
Height	152 mm	6.0 in
Width	76.2 mm	3.0 in
Thickness	12.7 mm	0.50 in
Front-Top/Bottom Plate		
Width	305 mm	12.0 in
Thickness	22.0 mm	0.87 in
Front Frame Structure		
Height	321 mm	12.6 in
Width	305 mm	12.0 in
Front Axle		
Height to Center	596 mm	23.5 in
Wheel Lean, Left/Right	18°	
Total Oscillation per Side	32°	

• Front-top/bottom plate – width tolerance  $\pm 2.5$  mm (0.098 in).

## Tandems

Height	506 mm	19.9 in
Width	201 mm	7.9 in
Sidewall Thickness		
Inner	16.0 mm	0.63 in
Outer	18.0 mm	0.71 in
Drive Chain Pitch	50.8 mm	2.0 in
Wheel Axle Spacing	1523 mm	60.0 in
Tandem Oscillation		
Front Up	15°	
Front Down	25°	

# 140/140 AWD Motor Graders Specifications

## Moldboard

Blade Width	3.7 m	12 ft
Moldboard		
Height	610 mm	24.0 in
Thickness	22.0 mm	0.87 in
Arc Radius	413 mm	16.3 in
Throat Clearance	166 mm	6.5 in
Cutting Edge		
Width	152 mm	6.0 in
Thickness	16.0 mm	0.60 in
End Bit		
Width	152 mm	6.0 in
Thickness	16.0 mm	0.60 in
Blade Pull		
Base GVW	11 462 kg	25,269 lb
Maximum GVW	15 541 kg	34,262 lb
Base GVW (AWD)	16 170 kg	35,649 lb
Maximum GVW (AWD)	22 512 kg	49,630 lb
Blade Down Pressure		
Base GVW	7275 kg	16,038 lb
Maximum GVW	13 294 kg	29,309 lb
Base GVW (AWD)	8151 kg	17,970 lb
Maximum GVW (AWD)	13 294 kg	29,309 lb

## Blade Range

Circle Centershift		
Right	728 mm	28.7 in
Left	695 mm	27.4 in
Moldboard Sideshift		
Right	660 mm	26.0 in
Left	510 mm	20.1 in
Maximum Blade Position Angle	90°	
Blade Tip Range		
Forward	40°	
Backward	5°	
Maximum Shoulder Reach Outside of Tires		
Right	1978 mm	77.9 in
Left	1790 mm	70.5 in
Maximum Lift Above Ground	480 mm	18.9 in
Maximum Depth of Cut	715 mm	28.1 in

## Ripper

Ripping Depth, Maximum	426 mm	16.8 in
Ripper Shank Holders	5	
Ripper Shank Holder Spacing	533 mm	21.0 in
Penetration Force	9440 kg	20,812 lb
Pryout Force	12 607 kg	27,794 lb
Machine Length Increase, Beam Raised	1031 mm	40.6 in

## Scarifier

Front, V-Type: Working Width	1205 mm	47.4 in
Front, V-Type, 5 or 11 Tooth		
Working Width	1031 mm	40.6 in
Scarifying Depth, Maximum	467 mm	18.4 in
Scarifier Shank Holders	5/11	
Scarifier Shank Holder Spacing	116 mm	4.6 in
Mid, V-Type		
Working Width	1184 mm	46.6 in
Scarifying Depth, Maximum	292 mm	11.5 in
Scarifier Shank Holders	11	
Scarifier Shank Holder Spacing	116 mm	4.6 in
Rear		
Working Width	2133 mm	84.0 in
Scarifying Depth, Maximum	426 mm	16.8 in
Scarifier Shank Holders	9	
Scarifier Shank Holder Spacing	267 mm	10.5 in

## Weights

Gross Vehicle Weight, Base		
Total	16 974 kg	37,420 lb
Front Axle	4238 kg	9,343 lb
Rear Axle	12 736 kg	28,077 lb
Gross Vehicle Weight, Maximum		
Total	25 013 kg	55,144 lb
Front Axle	7745 kg	17,075 lb
Rear Axle	17 268 kg	38,069 lb
Operating Weight, Typically Equipped		
Total	19 344 kg	42,647 lb
Front Axle	5468 kg	12,055 lb
Rear Axle	13 876 kg	30,592 lb

# 140/140 AWD Motor Graders Specifications

## Weights – AWD

Gross Vehicle Weight, Base		
Total	17 966 kg	39,609 lb
Front Axle	4749 kg	10,469 lb
Rear Axle	13 217 kg	29,140 lb
Gross Vehicle Weight, Maximum		
Total	25 013 kg	55,144 lb
Front Axle	7745 kg	17,075 lb
Rear Axle	17 268 kg	38,069 lb
Operating Weight, Typically Equipped		
Total	20 236 kg	44,614 lb
Front Axle	5945 kg	13,107 lb
Rear Axle	14 291 kg	31,507 lb

- Base operating weight on standard machine configuration is calculated with full fuel tank, coolant, lubricants, operator and 14.0R24 tires with single-piece (SP) rims.
- Typically equipped operating weight is calculated with push block, rear ripper/scarifier, 14.0R24 tires with single-piece (SP) rims, and other equipment.

## Standards

ROPS/FOPS	ISO 3471/ISO 3499
Steering	ISO 5010
Brakes	ISO 3450
Sound	ISO 6394; ISO 6395

- The declared dynamic operator sound pressure level is 71 dB(A) for the 140 and 140 AWD when “ISO 6396:2008” is used to measure the value for a European Union “CE” marked machine. The measurement was conducted at 70% of the maximum engine cooling fan speed. The sound level may vary at different engine cooling fan speeds.
- The declared exterior sound power level is 107 dB(A) for the 140 and 140 AWD when the value is measured according to the dynamic test procedures and the conditions that are specified in “ISO 6395:2008.” The measurement was conducted for a European Union “CE” marked machine at 70% of the maximum engine cooling fan speed. The sound level may vary at different engine cooling fan speeds and during diesel particulate filter regeneration.

## Air Conditioning System

The air conditioning system on this machine contains the fluorinated greenhouse gas refrigerant R134a (Global Warming Potential = 1430). The system contains 1.8 kg of refrigerant which has a CO<sub>2</sub> equivalent of 2.574 metric tonnes.

# 150/150 AWD Motor Graders Specifications

## Engine

Engine Model	Cat C9.3		
Emissions	U.S. EPA Tier 4 Final/ EU Stage V		
Base Power (1st gear) – Net	149 kW	200 hp	
Base Power (1st gear) – Net (Metric)	202 hp		
VHP Plus Range – Net	149-188 kW	200-252 hp	
VHP Plus Range – Net (Metric)	202-255 hp		
AWD Range – Net	156-203 kW	210-272 hp	
AWD Range – Net (Metric)	213-276 hp		
Displacement	9.3 L	567.5 in <sup>3</sup>	
Bore	115 mm	4.5 in	
Stroke	149 mm	5.9 in	
Torque Rise	39%		
Maximum Torque (VHP Plus)	1247 N·m	920 lb-ft	
Maximum Torque (AWD On)	1355 N·m	1,000 lb-ft	
Speed @ Rated Power	2,000 rpm		
Number of Cylinders	6		
Derating Altitude	3050 m	10,000 ft	
High Ambient – Fan Speed			
Standard	1,400 rpm		
Maximum	1,550 rpm		
Minimum	500 rpm		
Standard Capability	43° C	109° F	
High Ambient Capability	50° C	122° F	
	<b>VHP Plus</b>	<b>AWD Off</b>	<b>AWD On</b>
	<b>kW (hp)</b>	<b>kW (hp)</b>	<b>kW (hp)</b>
Gear – Net Power			
Forward			
1st	149 (200)	156 (210)	164 (220)
2nd	156 (210)	164 (220)	180 (241)
3rd	164 (220)	172 (231)	184 (247)
4th	172 (231)	176 (236)	188 (252)
5th	176 (236)	180 (241)	203 (272)
6th	180 (241)	184 (247)	203 (272)
7th	184 (247)	188 (252)	203 (272)
8th	188 (252)	188 (252)	203 (272)
Reverse			
1st	149 (200)	149 (200)	149 (200)
2nd	156 (210)	156 (210)	156 (210)
3rd–6th	164 (220)	164 (220)	164 (220)

## Engine (cont'd)

- Net power is tested per ISO 9249, SAE J1349, and EEC 80/1269 Standards in effect at the time of manufacture.
  - VHP Plus is standard for the 150/150 AWD.
  - Net power advertised is the power available at rated speed of 2,000 rpm, measured at the flywheel when engine is equipped with fan running at minimum speed, air cleaner, muffler and alternator.
  - No engine derating required up to 3050 m (10,000 ft).
  - Power as declared per ISO 14396  
Rated rpm 2,000  
VHP+ = 189 kW (253 hp)  
AWD = 204 kW (274 hp)
  - Cat engines equipped with a Selective Catalytic Reduction (SCR) system are required to use:
    - Diesel Exhaust Fluid (DEF) which meets the requirements outlined in the International Organization for Standardization (ISO) standard 22241-1.
  - Cat diesel engines are required to use ULSD (ultra-low sulfur diesel fuel with 15 ppm of sulfur or less) or ULSD blended with the following lower-carbon intensity fuels\*\* up to:
    - ✓ 20% biodiesel FAME (fatty acid methyl ester)\*
    - ✓ 100% renewable diesel, HVO (hydrotreated vegetable oil) and GTL (gas-to-liquid) fuels
- Refer to guidelines for successful application. Please consult your Cat dealer or “Caterpillar Machine Fluids Recommendations” (SEBU6250) for details.
- \*Engines with no aftertreatment devices can use higher blends, up to 100% biodiesel (for use of blends higher than 20% biodiesel, consult your Cat dealer).
- \*\*Tailpipe greenhouse gas emissions from lower-carbon intensity fuels are essentially the same as traditional fuels.

## Powertrain

Forward/Reverse Gears	8 Forward/6 Reverse
Transmission	APECS, Direct Drive, Powershift
Brakes	
Service	Multiple Oil Disc
Service, Surface Area	23 000 cm <sup>2</sup> 3,565 in <sup>2</sup>
Parking	Multiple Oil Disc
Secondary	Dual Circuit

## Hydraulic System

Circuit Type	Parallel
Pump Type	Variable Piston
Pump Output	210 L/min    55.7 gal/min
Maximum System Pressure	24 150 kPa    3,500 psi
Reservoir Tank Capacity	64.0 L    16.9 gal
Standby Pressure	6100 kPa    885 psi

- Pump output measured at 2,150 rpm.

# 150/150 AWD Motor Graders Specifications

## Operating Specifications

Top Speed		
Forward	46.6 km/h	29.0 mph
Reverse	36.8 km/h	23.0 mph
Turning Radius, Outside Front Tires		
	7.8 m	25 ft 7 in
Steering Range – Left/Right		
	50°	
Articulation Angle – Left/Right		
	20°	
Forward		
1st	4.1 km/h	2.5 mph
2nd	5.5 km/h	3.4 mph
3rd	8.0 km/h	5.0 mph
4th	11.0 km/h	6.9 mph
5th	17.1 km/h	10.6 mph
6th	23.3 km/h	14.5 mph
7th	32.0 km/h	19.9 mph
8th	46.6 km/h	29.0 mph
Reverse		
1st	3.2 km/h	2.0 mph
2nd	6.0 km/h	3.7 mph
3rd	8.7 km/h	5.4 mph
4th	13.5 km/h	8.4 mph
5th	25.3 km/h	15.7 mph
6th	36.8 km/h	23.0 mph

• Calculated with no slip and 14.0R24 tires.

## Service Refill

Fuel Capacity	394 L	104 gal
Cooling System	57.0 L	15.0 gal
Hydraulic System		
Total	100 L	26.4 gal
Tank	64.0 L	16.9 gal
Engine Oil	30.0 L	7.9 gal
Trans./Diff./Final Drives	70.0 L	18.5 gal
Tandem Housing (Each)	76.0 L	20.0 gal
Front Wheel Spindle Bearing Housing	0.5 L	0.13 gal
Circle Drive Housing	7.0 L	1.8 gal
Diesel Exhaust Fluid	22.0 L	5.8 gal

## Frame

Circle		
Diameter	1530 mm	60.2 in
Height	138 mm	5.4 in
Blade Beam Thickness	40.0 mm	1.6 in
Drawbar		
Height	152 mm	6.0 in
Width	76.2 mm	3.0 in
Thickness	12.7 mm	0.50 in
Front-Top/Bottom Plate		
Width	305 mm	12.0 in
Thickness	22.0 mm	0.87 in
Front Frame Structure		
Height	321 mm	12.6 in
Width	305 mm	12.0 in
Front Axle		
Height to Center	596 mm	23.5 in
Wheel Lean, Left/Right	18°	
Total Oscillation per Side	32°	

• Front-top/bottom plate – width tolerance  $\pm 2.5$  mm (0.098 in).

## Tandems

Height	506 mm	19.9 in
Width	201 mm	7.9 in
Sidewall Thickness		
Inner	16.0 mm	0.63 in
Outer	18.0 mm	0.71 in
Drive Chain Pitch	50.8 mm	2.0 in
Wheel Axle Spacing	1523 mm	60.0 in
Tandem Oscillation		
Front Up	15°	
Front Down	25°	



# 150/150 AWD Motor Graders Specifications

## Moldboard

Blade Width	3.7 m	12 ft
Moldboard		
Height	610 mm	24.0 in
Thickness	22.0 mm	0.87 in
Arc Radius	413 mm	16.3 in
Throat Clearance	166 mm	6.5 in
Cutting Edge		
Width	152 mm	6.0 in
Thickness	16.0 mm	0.60 in
End Bit		
Width	152 mm	6.0 in
Thickness	16.0 mm	0.60 in
Blade Pull		
Base GVW	11 672 kg	25,732 lb
Maximum GVW	15 541 kg	34,262 lb
Base GVW (AWD)	16 484 kg	36,341 lb
Maximum GVW (AWD)	22 512 kg	49,630 lb
Blade Down Pressure		
Base GVW	7475 kg	16,480 lb
Maximum GVW	13 294 kg	29,308 lb
Base GVW (AWD)	8351 kg	18,411 lb
Maximum GVW (AWD)	13 294 kg	29,308 lb

## Blade Range

Circle Centershift		
Right	728 mm	28.7 in
Left	695 mm	27.4 in
Moldboard Sideshift		
Right	660 mm	26.0 in
Left	510 mm	20.1 in
Maximum Blade Position Angle	90°	
Blade Tip Range		
Forward	40°	
Backward	5°	
Maximum Shoulder Reach Outside of Tires		
Right	1978 mm	77.9 in
Left	1790 mm	70.5 in
Maximum Lift Above Ground	480 mm	18.9 in
Maximum Depth of Cut	715 mm	28.1 in

## Ripper

Ripping Depth, Maximum	426 mm	16.8 in
Ripper Shank Holders	5	
Ripper Shank Holder Spacing	533 mm	21.0 in
Penetration Force	9440 kg	20,812 lb
Pryout Force	12 607 kg	27,794 lb
Machine Length Increase, Beam Raised	1031 mm	40.6 in

## Scarifier

Front, V-Type: Working Width	1205 mm	47.4 in
Front, V-Type, 5 or 11 Tooth		
Working Width	1031 mm	40.6 in
Scarifying Depth, Maximum	467 mm	18.4 in
Scarifier Shank Holders	5/11	
Scarifier Shank Holder Spacing	116 mm	4.6 in
Mid, V-Type		
Working Width	1184 mm	46.6 in
Scarifying Depth, Maximum	292 mm	11.5 in
Scarifier Shank Holders	11	
Scarifier Shank Holder Spacing	116 mm	4.6 in
Rear		
Working Width	2133 mm	84.0 in
Scarifying Depth, Maximum	426 mm	16.8 in
Scarifier Shank Holders	9	
Scarifier Shank Holder Spacing	267 mm	10.5 in

## Weights

Gross Vehicle Weight, Base		
Total	17 323 kg	38,191 lb
Front Axle	4355 kg	9,601 lb
Rear Axle	12 968 kg	28,590 lb
Gross Vehicle Weight, Maximum		
Total	25 013 kg	55,144 lb
Front Axle	7745 kg	17,075 lb
Rear Axle	17 268 kg	38,069 lb
Operating Weight, Typically Equipped		
Total	19 935 kg	43,950 lb
Front Axle	5692 kg	12,549 lb
Rear Axle	14 243 kg	31,401 lb

# 150/150 AWD Motor Graders Specifications

## Weights – AWD

Gross Vehicle Weight, Base		
Total	18 316 kg	40,380 lb
Front Axle	4865 kg	10,726 lb
Rear Axle	13 451 kg	29,654 lb
Gross Vehicle Weight, Maximum		
Total	25 013 kg	55,144 lb
Front Axle	7745 kg	17,075 lb
Rear Axle	17 268 kg	38,069 lb
Operating Weight, Typically Equipped		
Total	20 827 kg	45,917 lb
Front Axle	6169 kg	13,601 lb
Rear Axle	14 658 kg	32,316 lb

- Base operating weight on standard machine configuration is calculated with full fuel tank, coolant, lubricants, operator and 14.0R24 tires with multi-piece (MP) rims.
- Typically equipped operating weight is calculated with push block, transmission guard, rear ripper/scarifier, 14.0R24 tires with multi-piece (MP) rims, and other equipment.

## Standards

ROPS/FOPS	ISO 3471/ISO 3499
Steering	ISO 5010
Brakes	ISO 3450
Sound	ISO 6394; ISO 6395

- The declared dynamic operator sound pressure level is 71 dB(A) for the 150 and 150 AWD when “ISO 6396:2008” is used to measure the value for a European Union “CE” marked machine. The measurement was conducted at 70% of the maximum engine cooling fan speed. The sound level may vary at different engine cooling fan speeds.
- The declared exterior sound power level is 107 dB(A) for the 150 and 150 AWD when the value is measured according to the dynamic test procedures and the conditions that are specified in “ISO 6395:2008.” The measurement was conducted for a European Union “CE” marked machine at 70% of the maximum engine cooling fan speed. The sound level may vary at different engine cooling fan speeds and during diesel particulate filter regeneration.

## Air Conditioning System

The air conditioning system on this machine contains the fluorinated greenhouse gas refrigerant R134a (Global Warming Potential = 1430). The system contains 1.8 kg of refrigerant which has a CO<sub>2</sub> equivalent of 2.574 metric tonnes.

# 160/160 AWD Motor Graders Specifications

## Engine

Engine Model	Cat C9.3		
Emissions	U.S. EPA Tier 4 Final/ EU Stage V		
Base Power (1st gear) – Net	165 kW	221 hp	
Base Power (1st gear) – Net (Metric)	224 hp		
VHP Plus Range – Net	165-203 kW	221-272 hp	
VHP Plus Range – Net (Metric)	224-276 hp		
AWD Range – Net	172-219 kW	231-293 hp	
AWD Range – Net (Metric)	234-298 hp		
Displacement	9.3 L	567.5 in <sup>3</sup>	
Bore	115 mm	4.5 in	
Stroke	149 mm	5.9 in	
Torque Rise	39%		
Maximum Torque (VHP Plus)	1355 N·m	1,000 lb-ft	
Maximum Torque (AWD On)	1464 N·m	1,079 lb-ft	
Speed @ Rated Power	2,000 rpm		
Number of Cylinders	6		
Derating Altitude	3050 m	10,000 ft	
High Ambient – Fan Speed			
Standard	1,400 rpm		
Maximum	1,550 rpm		
Minimum	500 rpm		
Standard Capability	43° C	109° F	
High Ambient Capability	50° C	122° F	
Gear – Net Power	<b>VHP Plus kW (hp)</b>	<b>AWD Off kW (hp)</b>	<b>AWD On kW (hp)</b>
Forward			
1st	165 (221)	172 (231)	180 (241)
2nd	172 (231)	180 (241)	195 (262)
3rd	180 (241)	188 (252)	199 (267)
4th	188 (252)	191 (257)	203 (272)
5th	191 (257)	195 (262)	219 (293)
6th	195 (262)	199 (267)	219 (293)
7th	199 (267)	203 (272)	219 (293)
8th	203 (272)	203 (272)	219 (293)
Reverse			
1st	165 (221)	165 (221)	165 (221)
2nd	172 (231)	172 (231)	172 (231)
3rd–6th	180 (241)	180 (241)	180 (241)

## Engine (cont'd)

- Net power is tested per ISO 9249, SAE J1349, and EEC 80/1269 Standards in effect at the time of manufacture.
- VHP Plus is standard for the 160/160 AWD.
- Net power advertised is the power available at rated speed of 2,000 rpm, measured at the flywheel when engine is equipped with fan running at minimum speed, air cleaner, muffler and alternator.
- No engine derating required up to 3050 m (10,000 ft).
- Power as declared per ISO 14396  
Rated rpm 2,000  
VHP+ = 204 kW (274 hp)  
AWD = 220 kW (295 hp)
- All nonroad U.S. EPA Tier 4, European Union (EU) Stage V and Japan (MLIT) Step 4 diesel engines are required to use only Ultra Low Sulfur Diesel (ULSD) fuels containing 15 ppm (mg/kg) sulfur or less. Biodiesel blends up to B20 (20% blend by volume) are acceptable when blended with 15 ppm (mg/kg) sulfur or less ULSD. B20 should meet ASTM D7467 specification (biodiesel blend stock should meet Cat biodiesel spec, ASTM D6751 or EN 14214). Cat DEO-ULS or oils that meet the Cat ECF-3, API CJ-4, and ACEA E9 specification are required. Consult your OMM for further machine specific fuel recommendations.
- Cat engines equipped with a Selective Catalytic Reduction (SCR) system are required to use:
  - Diesel Exhaust Fluid (DEF) which meets the requirements outlined in the International Organization for Standardization (ISO) standard 22241-1.

## Powertrain

Forward/Reverse Gears	8 Forward/6 Reverse	
Transmission	APECS, Direct Drive, Powershift	
Brakes		
Service	Multiple Oil Disc	
Service, Surface Area	23 000 cm <sup>2</sup>	3,565 in <sup>2</sup>
Parking	Multiple Oil Disc	
Secondary	Dual Circuit Control	

## Hydraulic System

Circuit Type	Parallel	
Pump Type	Variable Piston	
Pump Output	210 L/min	55.5 gal/min
Maximum System Pressure	24 150 kPa	3,503 psi
Reservoir Tank Capacity	64.0 L	16.9 gal
Standby Pressure	6100 kPa	885 psi

- Pump output measured at 2,150 rpm.

# 160/160 AWD Motor Graders Specifications

## Operating Specifications

Top Speed		
Forward	47.4 km/h	29.5 mph
Reverse	37.4 km/h	23.3 mph
Turning Radius, Outside Front Tires		
	7.8 m	25 ft 7 in
Steering Range – Left/Right		
	50°	
Articulation Angle – Left/Right		
	20°	
Forward		
1st	4.1 km/h	2.6 mph
2nd	5.6 km/h	3.5 mph
3rd	8.1 km/h	5.1 mph
4th	11.2 km/h	7.0 mph
5th	17.4 km/h	10.8 mph
6th	23.7 km/h	14.7 mph
7th	32.6 km/h	20.3 mph
8th	47.4 km/h	29.5 mph
Reverse		
1st	3.3 km/h	2.0 mph
2nd	6.1 km/h	3.8 mph
3rd	8.8 km/h	5.5 mph
4th	13.7 km/h	8.5 mph
5th	25.7 km/h	16.0 mph
6th	37.4 km/h	23.3 mph

• Calculated with no slip and 14.0R24 tires.

## Service Refill

Fuel Capacity	394 L	104 gal
Cooling System	57.0 L	15.0 gal
Hydraulic System		
Total	100 L	26.4 gal
Tank	64.0 L	16.9 gal
Engine Oil	30.0 L	7.9 gal
Trans./Diff./Final Drives	70.0 L	18.5 gal
Tandem Housing (Each)	87.0 L	22.9 gal
Front Wheel Spindle Bearing Housing	0.5 L	0.13 gal
Circle Drive Housing	7.0 L	1.8 gal
Diesel Exhaust Fluid	22.0 L	5.8 gal

## Frame

Circle		
Diameter	1553 mm	61.1 in
Height	160 mm	6.3 in
Blade Beam Thickness	40.0 mm	1.6 in
Drawbar		
Height	152 mm	6.0 in
Width	76.2 mm	3.0 in
Thickness	12.7 mm	0.50 in
Front-Top/Bottom Plate		
Width	305 mm	12.0 in
Thickness	22.0 mm	0.87 in
Front Frame Structure		
Height	321 mm	12.6 in
Width	305 mm	12.0 in
Front Axle		
Height to Center	596 mm	23.5 in
Wheel Lean, Left/Right	18°	
Total Oscillation per Side	32°	

• Front-top/bottom plate – width tolerance  $\pm 2.5$  mm (0.098 in).

## Tandems

Height	572 mm	22.5 in
Width	204 mm	8.0 in
Sidewall Thickness		
Inner	17.5 mm	0.69 in
Outer	18.0 mm	0.71 in
Drive Chain Pitch	50.8 mm	2.0 in
Wheel Axle Spacing	1523 mm	60.0 in
Tandem Oscillation		
Front Up	15°	
Front Down	25°	

# 160/160 AWD Motor Graders Specifications

## Moldboard

Blade Width	4.2 m	14 ft
Moldboard		
Height	610 mm	24.0 in
Thickness	22.0 mm	0.87 in
Arc Radius	413 mm	16.3 in
Throat Clearance	166 mm	6.5 in
Cutting Edge		
Width	152 mm	6.0 in
Thickness	16.0 mm	0.60 in
End Bit		
Width	152 mm	6.0 in
Thickness	16.0 mm	0.60 in
Blade Pull		
Base GVW	11 762 kg	25,931 lb
Maximum GVW	15 541 kg	34,262 lb
Base GVW (AWD)	16 700 kg	36,817 lb
Maximum GVW (AWD)	22 512 kg	49,630 lb
Blade Down Pressure		
Base GVW	7713 kg	17,004 lb
Maximum GVW	13 294 kg	29,308 lb
Base GVW (AWD)	8589 kg	18,935 lb
Maximum GVW (AWD)	13 294 kg	29,308 lb

## Blade Range

Circle Centershift		
Right	728 mm	28.7 in
Left	695 mm	27.4 in
Moldboard Sideshift		
Right	660 mm	26.0 in
Left	510 mm	20.1 in
Maximum Blade Position Angle	90°	
Blade Tip Range		
Forward	40°	
Backward	5°	
Maximum Shoulder Reach Outside of Tires		
Right	2278 mm	89.7 in
Left	2090 mm	82.3 in
Maximum Lift Above Ground	452 mm	17.8 in
Maximum Depth of Cut	750 mm	29.5 in

## Ripper

Ripping Depth, Maximum	426 mm	16.8 in
Ripper Shank Holders	5	
Ripper Shank Holder Spacing	533 mm	21.0 in
Penetration Force	9440 kg	20,812 lb
Pryout Force	12 924 kg	28,493 lb
Machine Length Increase, Beam Raised	1031 mm	40.6 in

## Scarifier

Front, V-Type: Working Width	1205 mm	47.4 in
Front, V-Type, 5 or 11 Tooth		
Working Width	1031 mm	40.6 in
Scarifying Depth, Maximum	467 mm	18.4 in
Scarifier Shank Holders	5/11	
Scarifier Shank Holder Spacing	116 mm	4.6 in
Mid, V-Type		
Working Width	1184 mm	46.6 in
Scarifying Depth, Maximum	292 mm	11.5 in
Scarifier Shank Holders	11	
Scarifier Shank Holder Spacing	116 mm	4.6 in
Rear		
Working Width	2133 mm	84.0 in
Scarifying Depth, Maximum	426 mm	16.8 in
Scarifier Shank Holders	9	
Scarifier Shank Holder Spacing	267 mm	10.5 in

## Weights

Gross Vehicle Weight, Base		
Total	17 563 kg	38,719 lb
Front Axle	4494 kg	9,907 lb
Rear Axle	13 069 kg	28,812 lb
Gross Vehicle Weight, Maximum		
Total	25 013 kg	55,144 lb
Front Axle	7745 kg	17,075 lb
Rear Axle	17 268 kg	38,069 lb
Operating Weight, Typically Equipped		
Total	20 660 kg	45,547 lb
Front Axle	6004 kg	13,237 lb
Rear Axle	14 656 kg	32,310 lb

# 160/160 AWD Motor Graders Specifications

## Weights – AWD

Gross Vehicle Weight, Base		
Total	18 555 kg	40,908 lb
Front Axle	5004 kg	11,033 lb
Rear Axle	13 551 kg	29,875 lb
Gross Vehicle Weight, Maximum		
Total	25 013 kg	55,144 lb
Front Axle	7745 kg	17,075 lb
Rear Axle	17 268 kg	38,069 lb
Operating Weight, Typically Equipped		
Total	21 552 kg	47,514 lb
Front Axle	6481 kg	14,289 lb
Rear Axle	15 071 kg	33,225 lb

- Base operating weight on standard machine configuration is calculated with full fuel tank, coolant, lubricants, operator and 14.0R24 tires with multi-piece (MP) rims.
- Typically equipped operating weight is calculated with push block, transmission guard, rear ripper/scarifier, 17.5R25 tires with multi-piece (MP) rims, and other equipment.

## Standards

ROPS/FOPS	ISO 3471; ISO 3499
Steering	ISO 5010
Brakes	ISO 3450
Sound	ISO 6394; ISO 6395

- The declared dynamic operator sound pressure level is 71 dB(A) for the 160 and 160 AWD when “ISO 6396:2008” is used to measure the value for a European Union “CE” marked machine. The measurement was conducted at 70% of the maximum engine cooling fan speed. The sound level may vary at different engine cooling fan speeds.
- The declared exterior sound power level is 107 dB(A) for the 160 and 108 dB(A) for the 160 AWD when the value is measured according to the dynamic test procedures and the conditions that are specified in “ISO 6395:2008.” The measurement was conducted for a European Union “CE” marked machine at 70% of the maximum engine cooling fan speed. The sound level may vary at different engine cooling fan speeds and during diesel particulate filter regeneration.

## Air Conditioning System

The air conditioning system on this machine contains the fluorinated greenhouse gas refrigerant R134a (Global Warming Potential = 1430). The system contains 1.8 kg of refrigerant which has a CO<sub>2</sub> equivalent of 2.574 metric tonnes.

# Motor Graders Specifications

## Dimensions

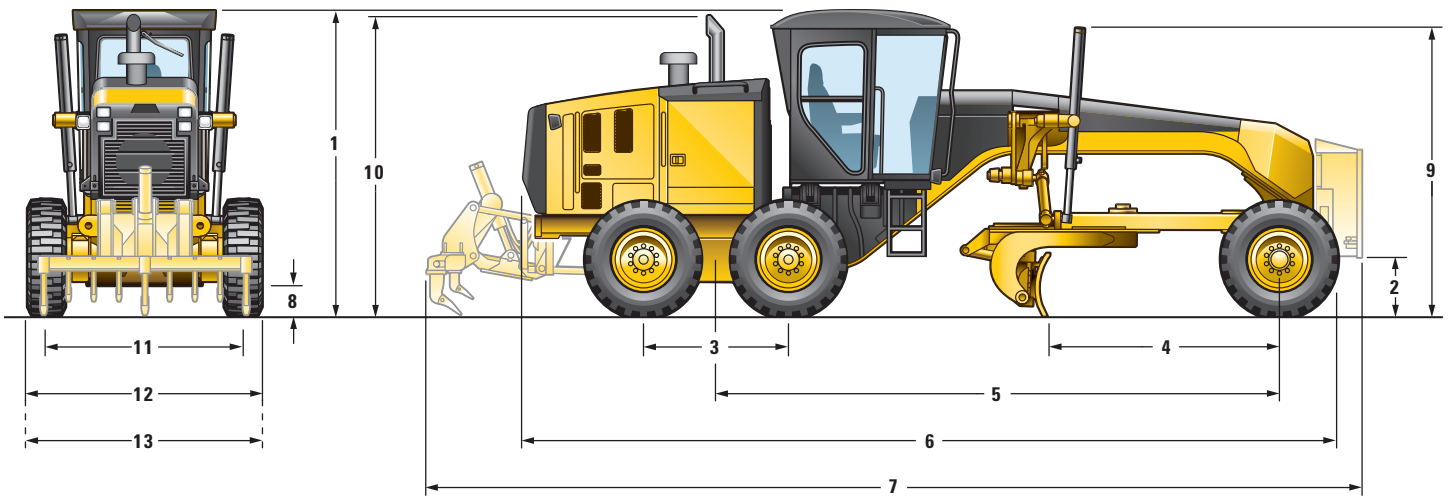

	140/140 AWD		150/150 AWD		160/160 AWD	
	mm	in	mm	in	mm	in
<b>1</b> Height – Top of Cab	3308	130	3308	130	3308	130
<b>2</b> Height – Front Axle Center	596	23.5	596	23.5	596	23.5
<b>3</b> Length – Between Tandem Axles	1523	60.0	1523	60.0	1523	60.0
<b>4</b> Length – Front Axle to Moldboard	2552	100	2552	100	2552	100
<b>5</b> Length – Front Axle to Mid Tandem	6123	241	6123	241	6123	241
<b>6</b> Length – Front Tire to Rear of Machine	8912	351	8912	351	8912	351
<b>7</b> Length – Counterweight to Ripper	10 136	399	10 136	399	10 136	399
<b>8</b> Ground Clearance at Rear Axle	339	13.3	339	13.3	339	13.3
<b>9</b> Height to Top of Cylinders	3040	120	3040	120	3040	120
<b>10</b> Height to Exhaust Stack	3256	128	3256	128	3256	128
<b>11</b> Width – Tire Center Lines	2140	84.3	2140	84.3	2140	84.3
<b>12</b> Width – Outside Rear Tires	2511	98.9	2511	98.9	2511	98.9
<b>13</b> Width – Outside Front Tires	2511	98.9	2511	98.9	2511	98.9

• Calculated with 14.0R24 Tires.

# Motor Graders Specifications

## Optional Tire Arrangements

### Common Tire Options

<b>140/140 AWD</b>			
<b>Rim Size</b>	<b>Wheel Group</b>	<b>Tires</b>	
9 × 24	Single-Piece	14.0R24	
13 × 25	Single-Piece	17.5R25	
10 × 24	Multi-Piece	14.0R24	
10 × 24	Multi-Piece	14.0-24	
14 × 25	Multi-Piece	17.5R25	
14 × 25	Multi-Piece	17.5-25	
<b>150/150 AWD</b>			
<b>Rim Size</b>	<b>Wheel Group</b>	<b>Tires</b>	
9 × 24	Single-Piece	14.0R24	
13 × 25	Single-Piece	17.5R25	
10 × 24	Multi-Piece	14.0R24	
10 × 24	Multi-Piece	14.0-24	
14 × 25	Multi-Piece	17.5R25	
14 × 25	Multi-Piece	17.5-25	
<b>160/160 AWD</b>			
<b>Rim Size</b>	<b>Wheel Group</b>	<b>Tires</b>	
9 × 24	Single-Piece	14.0R24	
13 × 25	Single-Piece	17.5R25	
10 × 24	Multi-Piece	14.0R24	
10 × 24	Multi-Piece	14.0-24	
14 × 25	Multi-Piece	17.5R25	
14 × 25	Multi-Piece	17.5-25	

**Note:** Consult your dealer for individual tire width, size and brand.



## Standard Equipment

Standard equipment may vary. Consult your Cat dealer for details.

### POWERTRAIN

- Air cleaner, dual stage, dry type, diesel, with automatic engine derate and automatic dust ejector, service indicator through Cat Messenger
- Air-to-air after cooler (ATAAC)
- Belt, serpentine, automatic tensioner
- Brakes, oil disc, four-wheel, hydraulic
- Demand fan, hydraulic, swing-out
- Diesel exhaust fluid tank, 22.0 L (5.8 gal) ground level access, and sediment drain
- Differential Lock/Unlock, Automatic
- Drain, engine oil, ecology
- Economy mode
- Electronic over speed protection
- Engine, C9.3, U.S. EPA Tier 4 Final/ EU Stage V emission standards
- Fuel tank, 394 L (104 gal), ground level access and sediment drain
- Parking brake – multi-disc, sealed, oil-cooled
- Priming pump, fuel
- Rear axle, modular
- Sediment drain, fuel tank
- Tandem drive
- Transmission, 8F/6R, powershift, direct drive, Advanced Productivity Electronic Control Strategy (APECS)

### ELECTRICAL

- Alarm, back up
- Alternator, 150 ampere, sealed
- Batteries, maintenance free, heavy duty, 1125 CCA
- Breaker panel, ground accessible
- Cab harness and electrical hydraulic valves
- Electrical system, 24V
- Grade Control Ready – Cab harness, software, electrical hydraulic valves, bosses and brackets
- Lights, roof-mounted roading, reversing, LED stop and tail
- Product Link
- Starter, electric

### OPERATOR ENVIRONMENT

- Accelerator
- Air conditioning with heater
- Arm and wrist rest, electronically adjustable
- Articulation, automatic Return-to-Center
- Cat Messenger operator information system
- Centershift pin indicator
- Coat hook
- Cup holder
- Display, digital speed and gear
- Doors, left and right side with wiper
- Gauge, machine level
- Gauge cluster (analog) – fuel, articulation, engine coolant temp, engine RPM, hydraulic oil temp, regen, DEF
- Hour meter, digital
- Joystick hydraulic controls right/left blade lift with float position, circle drive, blade sideshift and tip, centershift, front wheel lean, articulation and power steering
- Joystick, adjustable armrests
- Joystick gear selection
- Joystick hydraulic power steering
- Ladders, cab, left and right side
- Lights, night time cab
- Mirror, inside rearview, wide angle
- Power port, 12V
- Radio Ready, Entertainment
- ROPS cab, sound suppressed 70 dB(A)
- Seat, cloth-covered, comfort suspension
- Seat belt, retractable 76 mm (3 in)
- Storage area for cooler/lunchbox
- Throttle control, electronic
- Windows, laminated glass:
  - fixed front with intermittent wiper
  - door with intermittent wipers (3)
- Windows: tempered
  - left and right side wipers
  - rear and intermittent wiper

### FLUIDS

- Antifreeze
- Extended Life Coolant to  $-35^{\circ}\text{C}$  ( $-30^{\circ}\text{F}$ )

### TIRES, RIMS AND WHEELS

- Partial allowance for tires on  $254 \times 607$  mm ( $10 \times 24$  in) multi-piece rims is included in the base machine price and weight

### OTHER STANDARD EQUIPMENT

- Accumulators, brake, dual certified
- Anti-glare paint
- Bumper, rear, integrated with hitch
- CD ROM Parts Book
- Clutch, circle drive slip
- Cutting edges
  - $152 \times 16$  mm ( $6 \times 5/8$  in)
  - curved DH-2 steel
  - 19 mm ( $3/4$  in) mounting bolts
- Doors (3), engine compartment, locking
- Drawbar – 6 shoes, replaceable wear strips
- Electrical hydraulic valves, hydraulic lines for base 8 functions
- Endbits
  - 16 mm ( $5/8$  in) DH-2 steel
  - 19 mm ( $3/4$  in) mounting bolts
- Fluid check, ground level
- Frame, articulated, with safety lock
- Ground level engine shutdown
- Hammer (emergency exit)
- Horn, electric
- Hydraulic lines for base functions
- Lockout, hydraulic implement (for roading and servicing)
- Moldboard
- Mounting, cab roof accessories
- Pump, hydraulic, high capacity,  $98\text{ cm}^3$  ( $6\text{ in}^3$ )
- Radiator, cleanout access (both sides with swing doors)
- Secondary steering
- Serviceability, LH side
- S·O·S<sup>SM</sup> ports: engine, hydraulic, transmission, coolant, fuel
- Tandem walkway/guards
- Tool box

# Optional Equipment

## Optional Equipment

Optional equipment may vary. Consult your Cat dealer for details.

	kg*	lb*		kg*	lb*		kg*	lb*
<b>ELECTRICAL</b>			<b>POWERTRAIN</b>			<b>WORK TOOLS/G.E.T.</b>		
• Alternator, 280 ampere	2	5	• All Wheel Drive	892	1,967	• Blade extension, left hand, 610 mm (2 ft)	113	249
• Batteries:			• Precleaner, snow	2	5	• Blade extension, right hand, 610 mm (2 ft)	113	249
– extreme duty, 1,400 CCA	14	30	• Starter, extreme duty, 1,000 Amps	22	48	• Counterweight	427	939
• Lights:			• Transmission, autoshift	2	5	• Cutting edges, curved	43	95
– Headlights, high	38	84	<b>OTHER ATTACHMENTS</b>			• Endbits, overlay	24	52
– Headlights, low	35	77	• Auto Articulate			• Front lift group, mounting	5	11
– Working lights, basic	9	20	• Stable Blade			• Front lift group, mechanical	680	1,500
– Working lights, plus, LED	10	22	• Cat GRADE:			• Grader bit, narrow and super penetration	181	400
– Warning: beacon or strobe	2	5	– Digital Blade Slope Meter			• Mid-Mount Scarifier, Package	917	2,017
– Mounting for warning light	5	11	– Cross Slope Indicate			• Moldboard		
<b>GUARDS</b>			– Cross Slope			– 4267 mm × 610 mm × 22 mm (14 ft × 24 in × 7/8 in)	147	323
• Articulation guard	5	11	– Cat Production Measurement			– 4267 mm × 686 mm × 25 mm (14 ft × 27 in × 1 in)	284	625
• Fenders, front	121	266	• 3D ARO	46	101	<b>160/160 AWD only:</b>	472	1,040
• Fenders, front, AWD	56	124	• Integrated cross slope	47	103	– 4877 mm × 686 mm × 25 mm (16 ft × 27 in × 1 in)		
• Fenders, rear	156	344	• Accumulators, blade lift	55	121	• Push plate	1285	2,833
• Front axle guard	13	30	• Camera, rearview	9	20	• Ripper, rear	1042	2,292
• Sound suppression (bottom)	110	243	• Cat Product Link 321SR	13	29	• Ripper tooth	28	61
• Sound suppression (enclosure)	15	33	• Cat Product Link 522	13	29	• Scarifier, front	434	956
• Transmission	141	311	• Circle Saver	4.5	10	• Snow Arrangement	161	355
<b>OPERATOR ENVIRONMENT</b>			• Drain, ecology, engine Wiggins	2	5	• Snow Wing Ready Package	119	262
• Mirrors, outside:			• Heater, engine coolant:			• Tow hitch	53	116
– heated 24V	15	33	– 120V	1	3	<b>MACHINE ARRANGEMENTS</b>		
– mounted	15	33	– 240V	1	3	• Canadian Arrangement	2	4
• Comfort Plus Arrangement	2	4	• Hydraulic arrangements with one or more additional hydraulic valves are available for rear ripper, dozer, snow plow and snow wing.			• European Arrangement	289	637
• Comfort Premium Arrangement	3	7	• Snow wing mounting, frame ready	91	200	• TUV Rooding Arrangement	451	994
			• Starting aid, ether	0.5	1			
			• Reversing fan, automatic or manual	6	13			

\*Weights shown are to be added to the standard configuration when option is chosen.

The following information applies to the machine at the time of final manufacture as configured for sale in the regions covered in this document. The content of this declaration is valid as of the date issued; however, content related to machine features and specifications are subject to change without notice. For additional information, please see the machine's Operation and Maintenance Manual.

For more information on sustainability in action and our progress, please visit <https://www.caterpillar.com/en/company/sustainability>.

## Engine

- The Cat® C9.3 engine is available in configurations that meet U.S. EPA Tier 4 Final and EU Stage V emission standards.
- Cat diesel engines are required to use ULSD (ultra-low sulfur diesel fuel with 15 ppm of sulfur or less) or ULSD blended with the following lower-carbon intensity fuels\*\* up to:
  - ✓ 20% biodiesel FAME (fatty acid methyl ester)\*
  - ✓ 100% renewable diesel, HVO (hydrotreated vegetable oil) and GTL (gas-to-liquid) fuels

Refer to guidelines for successful application. Please consult your Cat dealer or “Caterpillar Machine Fluids Recommendations” (SEBU6250) for details.

*\*Engines with no aftertreatment devices can use higher blends, up to 100% biodiesel (for use of blends higher than 20% biodiesel, consult your Cat dealer).*

*\*\*Tailpipe greenhouse gas emissions from lower-carbon intensity fuels are essentially the same as traditional fuels.*

## Air Conditioning System

- The air conditioning system on this machine contains the fluorinated greenhouse gas refrigerant R134a (Global Warming Potential = 1430). The system contains 1.8 kg (3.9 lb) of refrigerant which has a CO<sub>2</sub> equivalent of 2.574 metric tonnes (2.837 tons).

## Paint

- Based on best available knowledge, the maximum allowable concentration, measured in parts per million (PPM), of the following heavy metals in paint are:
  - Barium < 0.01%
  - Cadmium < 0.01%
  - Chromium < 0.01%
  - Lead < 0.01%

## Sound Performance

- The declared dynamic operator sound pressure level is 71 dB(A) for the 140/140 AWD, 150/150 AWD and 160/160 AWD when “ISO 6396:2008” is used to measure the value for a European Union “CE” marked machine. The measurement was conducted at 70% of the maximum engine cooling fan speed. The sound level may vary at different engine cooling fan speeds.
- The declared exterior sound power level is 107 dB(A) for the 140/140 AWD, 150/150 AWD and 160 and is 108 dB(A) for the 160 AWD when the value is measured according to the dynamic test procedures and the conditions that are specified in “ISO 6395:2008.” The measurement was conducted for a European Union “CE” marked machine at 70% of the maximum engine cooling fan speed. The sound level may vary at different engine cooling fan speeds and during diesel particulate filter regeneration.

## Oils and Fluids

- Caterpillar factory fills with ethylene glycol coolants. Cat Diesel Engine Antifreeze/Coolant (DEAC) and Cat Extended Life Coolant (ELC) can be recycled. Consult your Cat dealer for more information.
- Cat Bio HYDO™ Advanced is an EU Ecolabel approved biodegradable hydraulic oil.

Additional fluids are likely to be present, please consult the Operations and Maintenance Manual or the Application and Installation guide for complete fluid recommendations and maintenance intervals.

## Features and Technology

- The following features and technology may contribute to fuel savings and/or carbon reduction. Features may vary. Consult your Cat dealer for details.
  - ECO mode minimizes fuel consumption for light applications
  - Engine Idle Shutdown Timer reduces fuel burn, greenhouse gas emissions and unnecessary idle time by shutting down the machine after a pre-set idling period
  - Cat Grade helps reduce fuel burn and greenhouse gas emissions by enabling you to achieve grade faster and more accurately by automating blade actions
  - Extended maintenance intervals not only reduce downtime but decrease the amount of fluid and filters that are replaced over the life of the machine
  - Automatic hydraulic demand fan reduces cooling demand allowing more power to the ground and improved fuel efficiency
  - Improve jobsite efficiency with lower operating costs with Product Link™ and VisionLink® insights

For more complete information on Cat products, dealer services, and industry solutions, visit us on the web at [www.cat.com](http://www.cat.com)

© 2023 Caterpillar  
All rights reserved

Materials and specifications are subject to change without notice. Featured machines in photos may include additional equipment. See your Cat dealer for available options.

CAT, CATERPILLAR, LET'S DO THE WORK, their respective logos, "Caterpillar Corporate Yellow," the "Power Edge" and Cat "Modern Hex" trade dress as well as corporate and product identity used herein, are trademarks of Caterpillar and may not be used without permission.

VisionLink is a trademark of Caterpillar Inc., registered in the United States and in other countries.

AEHQ7144-06 (11-2023)  
Replaces AEHQ7144-05  
(U.S. EPA Tier 4 Final,  
EU Stage V)  
Build Number: 15A

