



CS533E, CS533E XT, CP533E

VIBRATORY SOIL COMPACTORS



COMPACTORS YOU CAN COUNT ON

PROVEN PERFORMANCE, EXCEPTIONAL RELIABILITY

FIELD-TESTED PRODUCTIVITY

Contractors count on Cat® CS533E and CP533E Vibratory Soil Compactors to deliver outstanding compaction performance. What makes the compactors so productive? A combination of factors, including the pod-style vibratory system with proprietary eccentric weights, a propel system that handles gradeability with ease, and a powerful, reliable engine.

VIBRATORY SYSTEM

- Pod-style design incorporates proprietary eccentric weights for peak compaction performance
- System requires minimal service: 3 years/3000 hours oil change
- High dynamic forces help achieve compaction more quickly

ENGINE

- Cat 3054C turbocharged diesel
- 97 kW (130 hp)
- Built for performance, reliability and fuel economy

GRADEABILITY AND MACHINE CONTROL

- Exclusive dual-pump propel system provides balanced hydraulic flow to rear drive axle and front drum drive motor
- Outstanding grade climbing, machine control and tractive power
- System prevents spin-outs in low-traction conditions
- High working-speed capabilities increase productivity

COMFORT AND VISIBILITY

- Propel lever wrist rest, grouped control gauges and convenient control switches boost productivity, reduce operator fatigue
- Heavy-duty isolation mounts deliver a smooth ride
- Excellent visibility to rear tires and rear of machine
- Standard rearview mirrors and two front- and rear-facing working lights
- Open platform configurations feature handrails and angled footrests for work on grades



VERSATILITY

- Standard dual amplitude expands application range
- Large margin between high and low centrifugal force enables precise matching of compactive efforts and density specifications
- Works well on a wide variety of soil types and base materials

SERVICEABILITY

- Vibratory bearing has a lube service interval of 3 years/3,000 hours
- Engine lubrication change interval of 500 hours
- Articulation joint features maintenance-free bearings
- Easy access to engine, hydraulic components and daily check points

The durable, field-proven vibratory system enables your crews to achieve compaction in the fewest passes. Reliability and extended service intervals keep the compactors working.



COMPACTION PERFORMANCE

MEET SPECIFICATIONS IN FEWER PASSES

PROVEN SYSTEMS, PERFECT MATCHES

Cat vibratory systems are proven performers. The pod-style design and proprietary eccentric weights have been helping contractors meet or exceed compaction targets for years. Combine that performance with versatility—including padfoot shell kits that help you precisely match the machine to the jobsite—and you'll see bottom line results.

VIBRATORY SYSTEM

- Pod-style weight housings are assembled and sealed at the factory to ensure cleanliness, longer bearing life and easy service
- Dual amplitude works efficiently on a wide range of materials
- Eccentric weight shaft features large, heavy-duty bearings for high compactive forces
- 3 year/3,000 hour vibratory bearing lube service interval reduces maintenance requirements
- Heavy-duty isolation mounts enable transmission of more compactive force to the drum, and less vibration to the drum yoke

PROPRIETARY ECCENTRIC WEIGHTS

- Reliable dual amplitude selection and innovative design ensure precise performance
- Selection switch at operator's fingertips for simplified control
- Reliability is superior to swinging mechanical weights
- Quieter than mechanical weights during starts and stops
- Long service life because weights don't collide; no metal fragments to contaminate bearing lubrication system

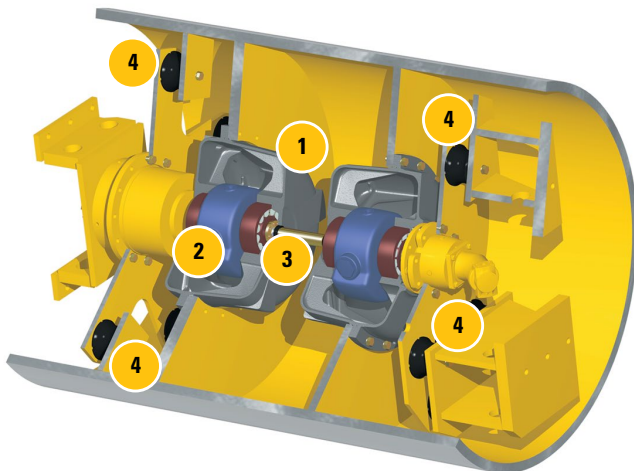

1. Pod-style Weight Housings
2. Proprietary Eccentric Weights
3. Heavy-duty Bearings
4. Isolation Mounts

High Amplitude

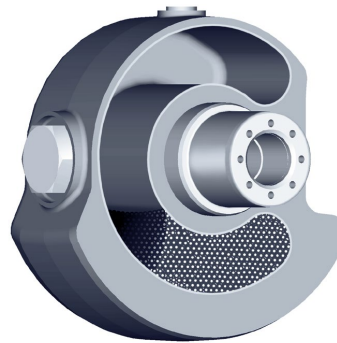

Low Amplitude

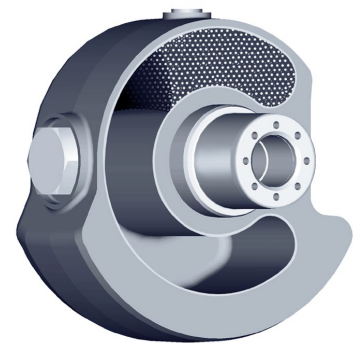

HOW AN ECCENTRIC WEIGHT WORKS ...

1. Hollow eccentric weight is filled with steel shot.
2. Spinning weight repositions shot leading to positive amplitude selection.
3. Direction of the weight shaft rotation determines amplitude level.

The dual-purpose bumper, included with the padfoot shell kit, is designed to remain on the compactor after installation. The bumper provides adjustable scrapers that can be utilized on the standard smooth drum or the shell kit.

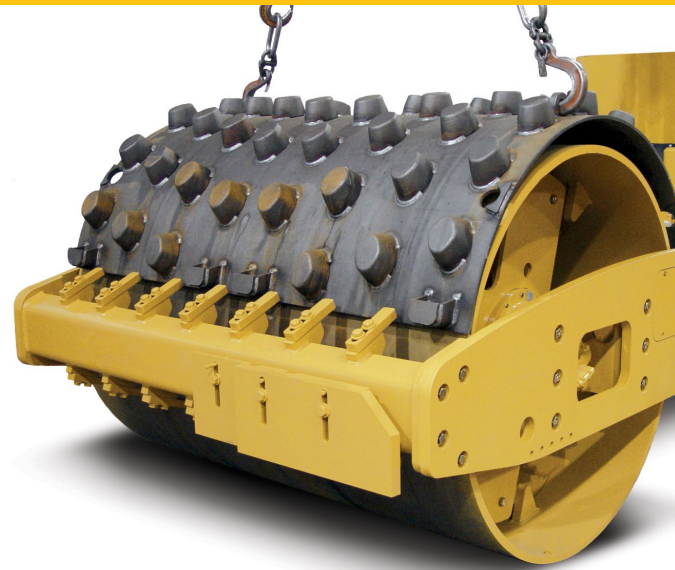

PADFOOT DRUM AND SCRAPERS

- Provides superior performance when compacting cohesive or semi-cohesive materials
- Heavy-duty scrapers on front and rear of drum yoke are individually adjustable and replaceable
- Padfoot drum has 140 welded pads in chevron arrangement
- Tapered design helps keep pads cleaner, even in sticky materials

PADFOOT SHELL KIT

- Padfoot shell halves can be installed or removed in about an hour with an approved lifting device
- Expands application of compactors to work in either cohesive or semi-cohesive materials
- Is a cost-effective solution for jobs that require both padfoot and smooth drum compaction

ROUND PAD DESIGN

- Good fit when compacting cohesive materials, particularly clay
- Each pad has a height of 127 mm (5 in) and a pad surface area of 89.4 cm² (13.9 in²)
- Tall pad height for deep penetration makes them ideal fits for thick lifts in the range of 25-45 cm (10-18 in)
- Smaller pad surface enables higher ground contact pressure to achieve density specifications more quickly

SQUARE PAD DESIGN

- Primarily used when compacting semi-cohesive materials such as sand, gravel or silt with a small amount of clay
- Pad height of 100 mm (3.9 in) and pad surface area of 140 cm² (21.7 in²)
- Shorter pad height, and large pad-face surface area, enable high ground contact pressure to achieve target density specifications
- Pad height and surface area provide a tight surface closure



OPERATOR COMFORT AND VISIBILITY

ENHANCES PRODUCTIVITY

LESS VIBRATION, ERGONOMIC DESIGN

Comfort and productivity go hand-in-hand. Reduced vibration and a comfortable seat helps operators focus on work, while ergonomic controls make operation smooth and easy. Good visibility promotes awareness of obstructions and other workers, particularly when maneuvering. The result: significant productivity gains.



OPEN PLATFORM WITH ROPS/FOPS CANOPY

- Enclosed by handrails with angled footrests for sure footing and support when working on a grade
- Spacious and comfortable working environment, with all controls, levers, switches and gauges positioned to maximize productivity
- Standard equipment includes two front-facing and two rear-facing working lights; a rear-view mirror; a lockable vandalism cover; and handrails with angled footrests



SLOPED HOOD DESIGN

- Exceptional visibility to the tire edges and rear of the machine
- Enables operators to see obstacles measuring 1 m (39 in) high that are located 1 m (39 in) to the rear
- Lockable hood opens easily to provide convenient access to engine, cooling system and service points
- Reduces sound levels for operator and crew
- Routes cooling air through the rear-mounted radiator

OPERATOR STATION

- Single-lever control for propel and vibratory “on/off” provides simple, low-effort operation
- Padded, adjustable wrist rest increases operator comfort
- Comfortable, durable seat is easily adjustable
- Flip-up arm rests on seat for easy access
- Four heavy-duty rubber isolation mounts limit transmission of machine vibration to the operator station
- Floor mat provides sure footing and greater insulation from vibration and noise



PROPERLY POWERED

BUILT TO HANDLE CHALLENGING WORK

ENGINE, DUAL-PUMP PROPEL SYSTEM DELIVER

The high-tech, four-cylinder Cat 3054C turbocharged diesel engine provides outstanding durability, performance, reliability and operating economy. The dual-pump propel system delivers high-tractive effort and gradeability for outstanding productivity in tough applications.

CAT 3054C TURBO ENGINE

- Air-to-air aftercooling packs cooler, denser air into cylinders for more complete combustion, enhanced fuel economy and lower emissions
- Direct injection of fuel enables maximum efficiency
- Cross-flow cylinder head improves cylinder air intake, increasing power while reducing fuel consumption, emissions and noise
- Low-mounted oil pump provides quick start-up lubrication
- Large oil cooler extends services intervals, reduces oil degradation and varnishing of internal components
- Engine meets EU Stage II and U.S. EPA Tier 2 standards

DUAL-PUMP PROPEL SYSTEM

- Provides separate, balanced hydraulic flow to the rear drive axle and the front drum drive motor
- Delivers plenty of power to compact on moderate slopes
- Consistent tractive effort in loose or poor underfoot conditions
- Limited-slip differential provides balanced tractive effort and smooth torque transfer to both rear wheels
- Two speed ranges enable versatility, from vibratory power on grades, or speed when moving quickly over longer distances
- Flushing valves in each propel circuit keep hydraulic oil cool and clean for maximum system efficiency

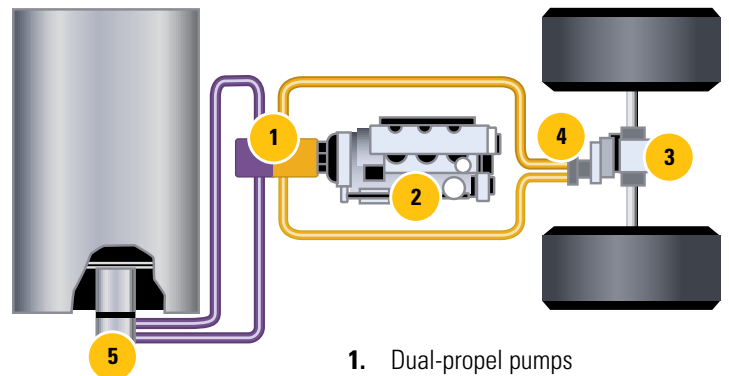
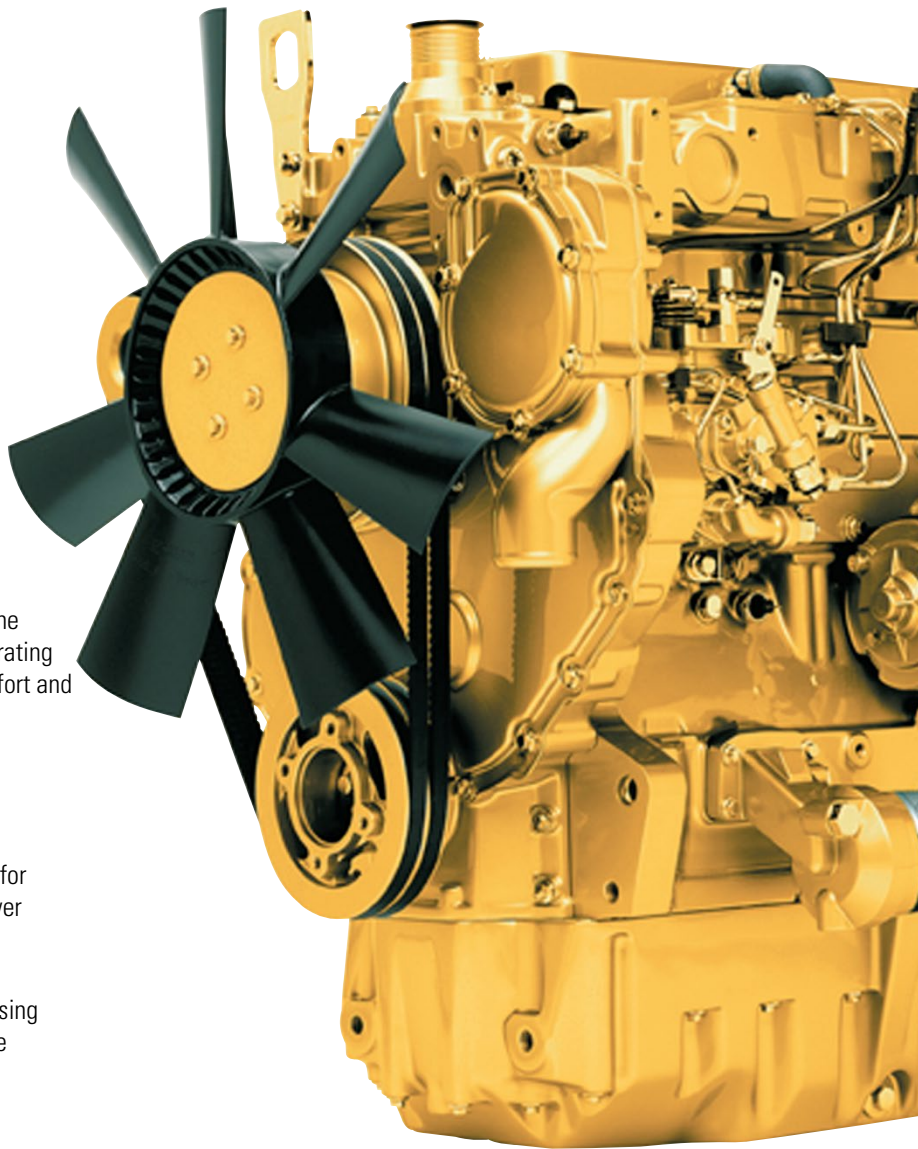

1. Dual-propel pumps
2. Cat 3054C engine
3. Limited-slip differential
4. Rear drive axle
5. Front drum drive motor

Built to exceed performance requirements, the robust system design contributes to the durability and reliability of Cat powertrains.

RELIABILITY AND SERVICEABILITY

KEEP MACHINES HARD AT WORK

DURABILITY BUILT IN

Reliability starts at the factory, where durable components and solid design are implemented with the knowledge they will work longer, even on demanding jobsites. Serviceability is another consideration in the design. Preventive maintenance is a necessity, so machines that are easy to service spend more time doing what they are supposed to be doing—working.

EASY MAINTENANCE

- Visual indicators facilitate quick monitoring of engine coolant, hydraulic fluid and air filter restriction
- Operator station tilts forward for easy access to hydraulic pumps
- Rear-mounted cooling system makes cleaning easy; hydraulic oil cooler tilts rearward for additional radiator access
- Sealed-for-life bearings in articulation joint eliminate need for greasing or other maintenance
- 500-hour engine oil change interval reduces service work
- 3-year/3,000-hour vibratory bearing lube service interval reduces maintenance needs
- Quick-connect hydraulic test ports simplify system diagnostics
- Ecology drains reduce the chance of spills that can occur when changing fluids and are included on radiator, engine oil pan, hydraulic tank and fuel tank
- S•O•SSM ports allow for simple fluid collection
- Secure hose routing with polythene mounting blocks reduces rubbing, increases service life
- Nylon-braided wrap and all-weather connectors ensure electrical system integrity
- Electrical wiring color-coded, numbered and labeled to simplify troubleshooting
- Maintenance-free Cat batteries mounted in the rear of the machine are protected by the engine hood
- Available Product Link[™] System ensures maximum uptime and minimum repair costs by simplifying tracking of equipment fleets, and providing automatic machine and hour updates



COMPACTION DEPTH FOR PRODUCTION CLASS VIBRATORY SOIL COMPACTORS (10-19 METRIC TONS)

Assumes density specification is 95% of Standard Proctor and can vary substantially due to different soil conditions.

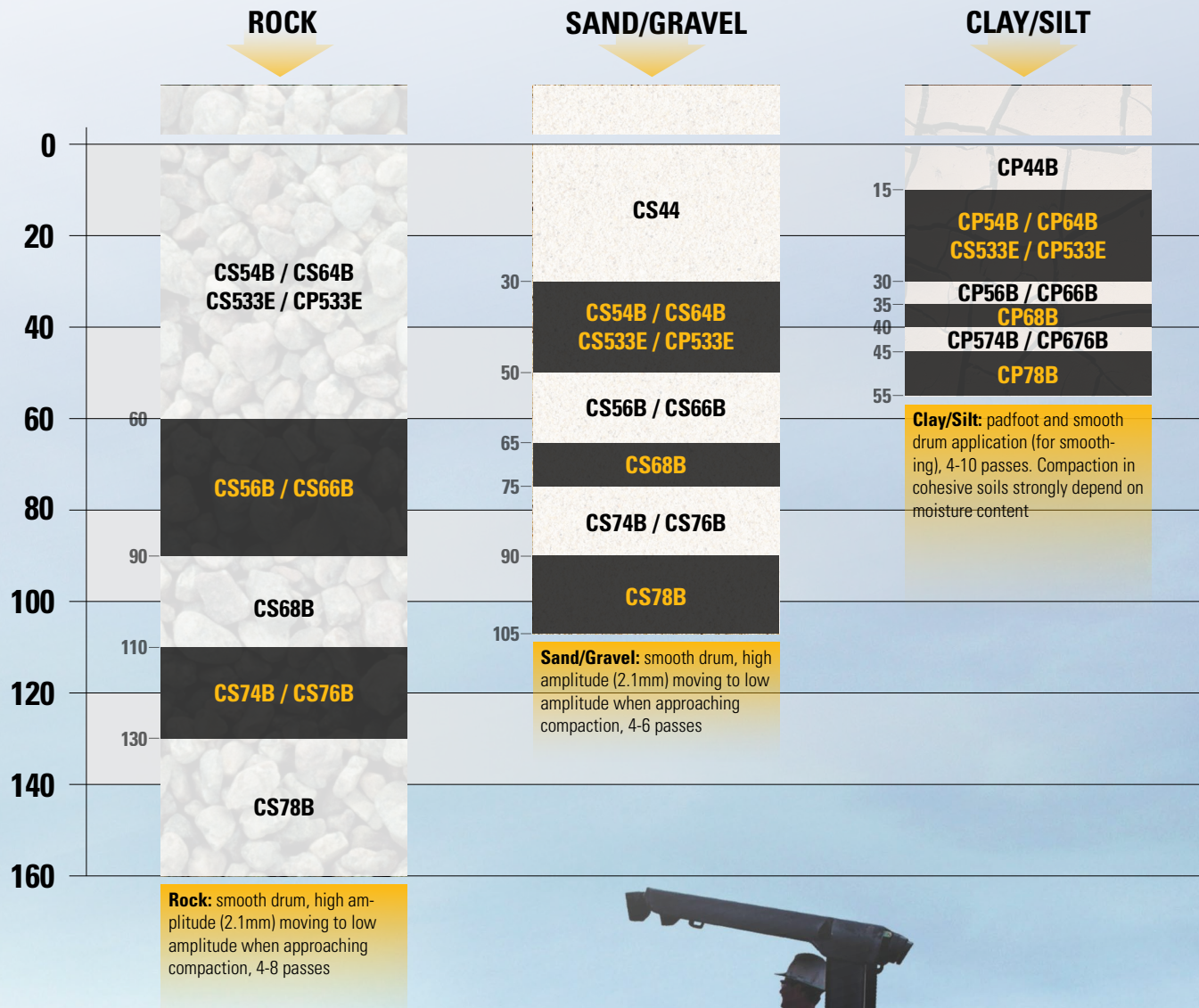

*CS64B, CS66B and CS76B are European Models Only

SPECIFICATIONS

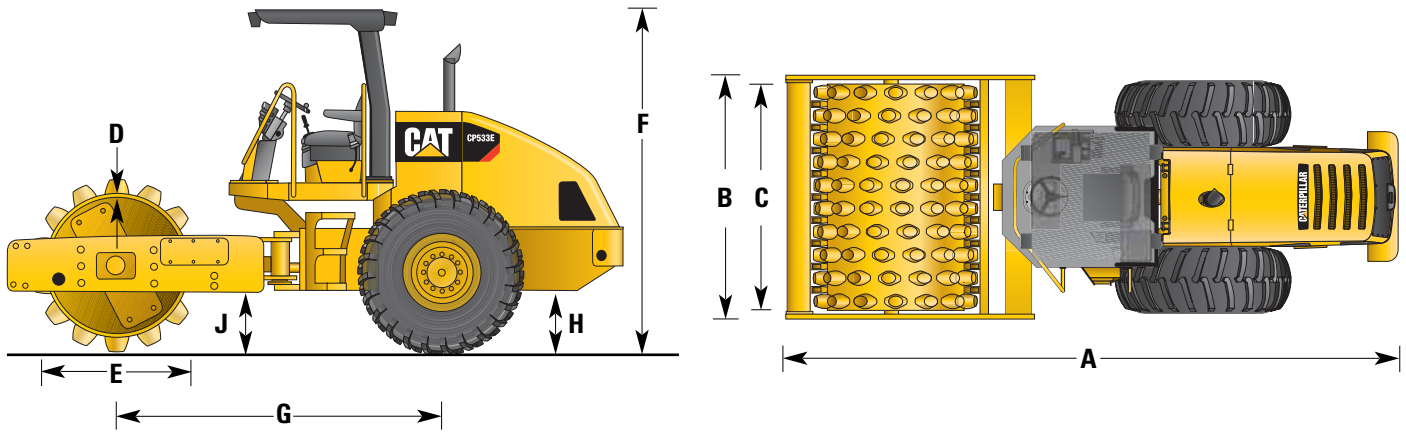

	CS533E	CS533E XT	CP533E*
Machine Dimensions			
A. Overall length - m (ft/in)	5.51 m (18' 1")	5.51 m (18' 1")	5.51 m (18' 1")
B. Overall width - m (ft/in)	2.29 m (7' 6")	2.36 m (7' 7")	2.29 m (7' 6")
C. Drum width - m (ft/in)	2.13 m (7')	2.13 m (7')	2.13 m (7')
D. Drum shell thickness - mm (in)	25 mm (1")	25 mm (1")	25 mm (1")
E. Drum diameter - mm (in)	1534 mm (60.4")	1534 mm (60.4")	1295 mm (51")
Drum diameter over std. pads - mm (in)	—	—	1549 mm (61")
F. Height at ROPS/FOPS canopy - m (ft/in)	3.06 m (10' 1")	3.06 m (10' 1")	3.07 m (10' 1")
Height at ROPS/FOPS cab - m (ft/in)	3.07 m (10' 1")	3.07 m (10' 1")	3.07 m (10' 1")
G. Wheelbase - m (ft/in)	2.90 m (9' 6")	2.90 m (9' 6")	2.90 m (9' 6")
H. Ground clearance - mm (in)	543 mm (21.4")	543 mm (21.4")	543 mm (21.4")
J. Curb clearance - mm (in)	521 mm (20.5")	521 mm (20.5")	521 mm (20.5")
Inside turning radius - m (ft/in)	3.68 m (12' 1")	3.68 m (12' 1")	3.68 m (12' 1")
Outside turning radius - m (ft/in)	5.81 m (19' 1")	5.81 m (19' 1")	5.81 m (19' 1")
Powertrain			
Engine	3054C	3054C	3054C
Gross power	97 kW (130 hp)	97 kW (130 hp)	97 kW (130 hp)
Maximum speeds			
High range	12.0 km/h (7.5 mph)	12.0 km/h (7.5 mph)	12.0 km/h (7.5 mph)
Low range	8.0 km/h (4.9 mph)	8.0 km/h (4.9 mph)	8.0 km/h (4.9 mph)
Axle (differential)	Limited Slip	Limited Slip	Limited Slip
Tire size	587 mm x 660 mm (23.1" x 26") 12-ply	587 mm x 660 mm (23.1" x 26") 12-ply	587 mm x 660 mm (23.1" x 26") 14-ply
Miscellaneous			
Electrical system	24 VDC	24 VDC	24 VDC
Articulation angle	± 34°	± 34°	± 34°
Oscillation angle	± 15°	± 15°	± 15°
Fuel capacity	200 liters (53 gal)	200 liters (53 gal)	200 liters (53 gal)

*Add 30 kg (66 lbs) to all CP533E weights shown above to reflect the optional square pad design padfoot drum

SPECIFICATIONS

	CS533E	CS533E XT	CP533E*
Operating Weight			
Machine Weights	10 265 kg (22,635 lb)	11 760 kg (25,926 lb)	11 100 kg (24,475 lb)
with open platform - kg (lb)			
with ROPS/FOPS canopy - kg (lb)	10 485 kg (23,120 lb)	12 000 kg (26,455)	11 320 kg (24,960 lb)
equipped with padfoot shell kit - kg (lb)	11 910 k (26,260 lb)	—	—
with ROPS/FOPS cab - kg (lb)	10 840 kg (23,900 lb)	12 360 kg (27,249)	11 530 kg (25,425 lb)
Weight at Drum			
with open platform - kg (lb)	5510 kg (12,150 lb)	6 780 kg (14,947)	6180 kg (13,630 lb)
with ROPS/FOPS canopy - kg (lb)	5570 kg (12,280 lb)	6 840 kg (15,079)	6240 kg (13,760 lb)
equipped with padfoot shell kit - kg (lb)	6990 kg (15,415 lb)	—	—
with ROPS/FOPS cab - kg (lb)	5760 kg (12,700 lb)	7 030 kg (15,498)	6300 kg (13,890 lb)
Operating Weights (with ROPS/FOPS)			
Machine - kg (lb)	10 485 kg (23,120 lb)	11 750 kg (25,904)	11 320 kg (24,960 lb)
at drum - kg (lb)	5570 kg (12,280 lb)	6 840 kg (15,079)	6240 kg (13,760 lb)
Static linear load (at drum)	26.1 kg/cm (146 lb/in)	32 kg/cm (179 lb/in)	—
Vibratory System			
Frequency			
High amplitude	31 Hz (1860 vpm)	31 Hz (1860 vpm)	31.9 Hz (1914 vpm)
Low amplitude	34 Hz (2040 vpm)	34 Hz (2040 vpm)	31.9 Hz (1914 vpm)
Nominal amplitude			
High	1.8 mm (0.071")	1.8 mm (0.071")	1.7 mm (0.067")
Low	0.85 mm (0.033")	0.85 mm (0.033")	0.85 mm (0.033")
High (with padfoot shell kit)	1.2 mm (0.047")	1.2 mm (0.047")	—
Low (with padfoot shell kit)	0.6 mm (0.024")	0.6 mm (0.024")	—
Centrifugal force			
Maximum	234 kN (52,600 lb)	234 kN (52,600 lb)	266 kN (60,000 lb)
Minimum	133 kN (30,000 lb)	133 kN (30,000 lb)	133 kN (30,000 lb)
Maximum (with padfoot shell kit)	234 kN (52,600 lb)	234 kN (52,600 lb)	—
Minimum (with padfoot shell kit)	133 kN (30,000 lb)	133 kN (30,000 lb)	—

	Shell Kit	Padfoot
Shell Kit / Padfoot Performance		
Number of Pads	120	140
Pad Height, oval pads	90 mm 3.5 in	127 mm 5 in
Pad Face Area, oval pads	63.5 cm ² 9.8 in ²	74.4 cm ² 11.5 in ²
Pad Height, optional square pads	90 mm 3.5 in	100 mm 3.9 in
Pad Face Area, optional square pads	123 cm ² 19.1 in ²	123 cm ² 19.1 in ²
Number of Chevrons	16	14

Cat CS533E, CS533E XT and CP533E Vibratory Soil Compactors

For more complete information on Cat products, dealer services, and industry solutions, visit us on the web at www.cat.com

© 2018 Caterpillar
All Rights Reserved

Materials and specifications are subject to change without notice.
Featured machines in photos may include additional equipment.
See your Cat Dealer for available options.

CAT, CATERPILLAR, BUILT FOR IT, their respective logos, "Caterpillar Yellow," the "Power Edge" trade dress as well as corporate and product identity used herein, are trademarks of Caterpillar and may not be used without permission.

QEHQ1791-03 (06/18)
Replaces QEHQ9995 and HEHQ9995-02

