



Cat[®] CP54B

Padfoot Drum Vibratory Soil Compactor

The Cat[®] CP54B features a padfoot drum and is ideally suited for cohesive and semi-cohesive soil applications.

Comfortable and Ergonomic Operator Station

- Features pivoting seat with integrated multifunction LCD display and control console.
- Outstanding visibility to the front and rear of machine.
- Low sound levels and vibration for greater operator comfort and productivity.

Rear Vision Camera

- The rear vision camera enhances visibility for more complete operator control and safety.

Exceptional Propel System

- Built around the exclusive Cat dual pump propel system, two pumps provide separate dedicated flow to drum drive motor and rear axle motor for exceptional gradeability and traction in forward and reverse.
- Electronic propel control provides more precise machine control.

Virtually Maintenance Free

- Maintenance-free hitch bearings.
- Extended maintenance intervals for vibratory system and hydraulic system, providing more uptime and lower maintenance costs.

Enhanced Compaction Performance

- More weight at the drum and greater amplitude.
- Auto-vibe function makes it easy to ensure consistent, high quality compaction.

Technologies that Enhance Quality and Productivity

- Measurement and documentation technologies help the operator determine when compaction has been completed to specification for greater productivity and uniform compaction quality.
- Machine Drive Power (MDP) measurement technology available.



Cat® CP54B Vibratory Soil Compactor

Standard and Optional Equipment

Standard and optional equipment may vary. Consult your Cat dealer for details.

	Standard	Optional		Standard	Optional
OPERATOR ENVIRONMENT			POWERTRAIN		
ROPS/FOPS Canopy with Handrails/ Guardrails, Floor Mat	✓		Cat® C4.4 Diesel Engine	✓	
Vinyl Adjustable Pivoting Seat with Integrated Console and LCD Display	✓		Air Cleaner, Dual Element	✓	
Adjustable Tilting Steering Column with Integrated Cup Holders	✓		Three-Speed Throttle Switch, Eco-mode, and Automatic Speed Control	✓	
Rear Vision Camera with Color Touchscreen Display	✓		Dual Propel Pumps; One for Drum Drive, One for Rear Axle	✓	
Seat Belt	✓		Fuel Filter, Water Separator, Priming Pump, Water Indicator	✓	
12-volt Power Outlet	✓		Tilting Radiator/Hydraulic Oil Cooler	✓	
Horn, Backup Alarm	✓		Dual Braking System	✓	
ROPS/FOPS Cab with Climate Control		✓	Two-speed Hydrostatic Transmission	✓	
Internal Rear View Mirror		✓	Transmission Guard		✓
External Rear View Mirrors		✓	CAT COMPACTION CONTROL TECHNOLOGY		
Sun Visor		✓	Measure - Machine Drive Power		✓
Cab Internal Roll-down Sun Screen		✓	Map - SBAS GNSS Mapping		✓
VIBRATORY SYSTEM			Connect - Cloud and Machine Connectivity		✓
Padfoot Drum	✓		ELECTRICAL		
Dual Amplitude, Single Frequency	✓		24 volt Electrical System	✓	
Dual Pod-Style Eccentric Weight Housings	✓		100 ampere Alternator	✓	
Auto-vibe Function	✓		750 Cold-cranking Amps Battery Capacity	✓	
Dual Adjustable Steel Scrapers	✓		OTHER		
Variable Frequency		✓	Product Link™	✓	
			Sight Gauges for Hydraulic Oil Level and Radiator Coolant Level	✓	
			S•O•S SM Sampling Valves: Engine Oil, Hydraulic Oil, and Coolant	✓	
			Upgraded Halogen Light Package		✓
			Rotating Amber Beacon		✓
			Fuel Fill Access Door		✓

Vibratory Soil Compactor Selection Guide

10 - 15 T

Assumes density specification is 95% of Standard Proctor and can vary substantially due to different soil conditions.

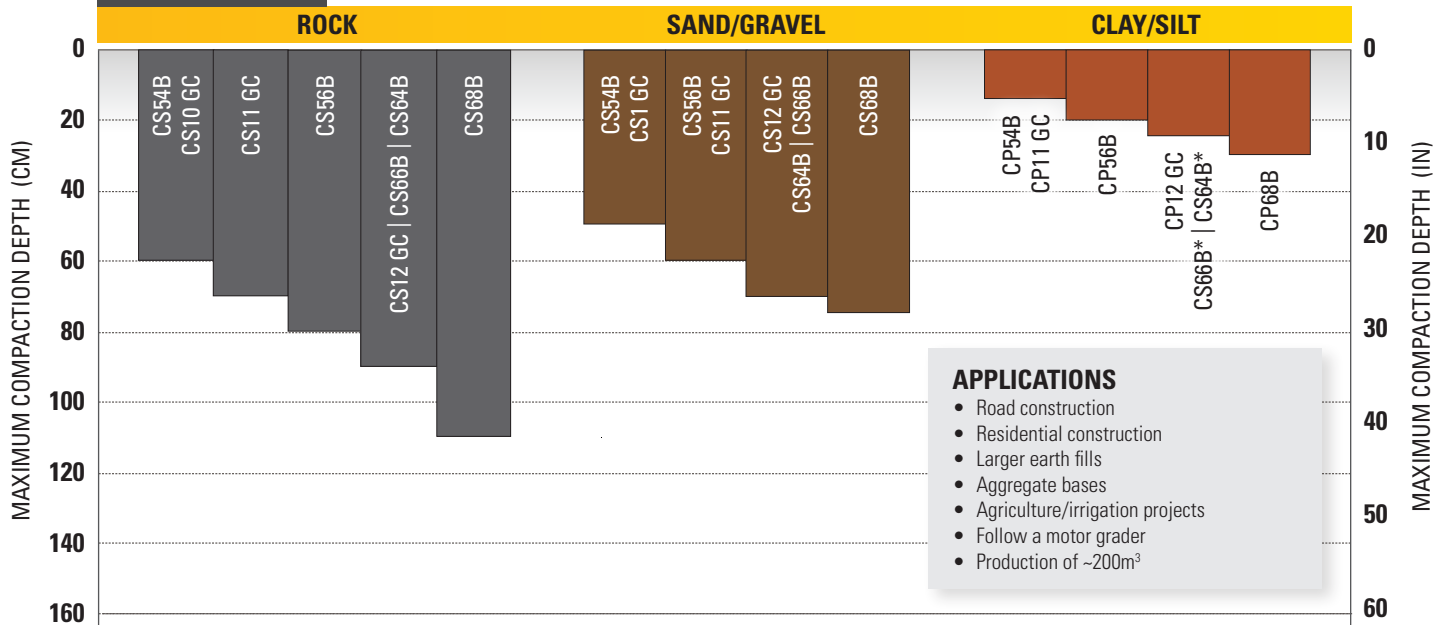

APPLICATIONS

- Road construction
- Residential construction
- Larger earth fills
- Aggregate bases
- Agriculture/irrigation projects
- Follow a motor grader
- Production of ~200m³

Rock

Smooth drum, high amplitude moving to low amplitude when approaching compaction, 4-8 passes

Size: Less than 50 mm (2 in) diameter

Sand/Gravel

Smooth drum, high amplitude moving to low amplitude when approaching compaction, 4-6 passes

Clay/Silt

Padfoot and smooth drum application (for smoothing), 4-10 passes. Compaction in cohesive soils strongly depends on moisture content.

* Smooth drum model equipped with padfoot shell kit

Cat® CP54B Vibratory Soil Compactor

Technical Specifications

Engine - Powertrain

Engine Model	Cat C4.4	
Emissions	U.S. EPA Tier 4 Final EU Stage IV	
Engine Power ISO 14396:2002	97.9 kW	131.3 hp
Gross Power SAE J1995:2014	99.0 kW	132.8 hp
Net Power ISO 9249:2007*	81.9 kW	109.8 hp
Net Power SAE J1349:2011*	80.2 kW	108.4 hp
Displacement	4.4 L	268.5 in ³
Stroke	127 mm	5 in
Bore	105 mm	4.1 in
Max. Travel Speed (Forward or Reverse)	11 km/h	6.8 mph
Theoretical Gradeability, with or without vibration**	54%	

Weights

Operating Weight w/ ROPS/FOPS canopy	10 935 kg	24,096 lb
Operating Weight w/ ROPS/FOPS cab	11 135 kg	24,539 lb
Weight at Drum w/ ROPS/FOPS canopy	6300 kg	13,887 lb
Weight at Drum w/ ROPS/FOPS cab	6395 kg	14,092 lb

* Net power advertised is the power available at the engine flywheel when equipped with a fan at maximum speed, air cleaner, and alternator.

** Actual gradeability may vary based on site conditions and machine configuration. Refer to the Operation and Maintenance Manual for more information.

Vibratory System Specifications

Frequency		
Standard	30.5 Hz	1830 vpm
During Eco-mode Operation	27.7 Hz	1664 vpm
Optional Variable Frequency	23.3-30.5 Hz	1400-1830 vpm
Nominal Amplitude @ 30.5 Hz (1830 vpm)		
High	1.8 mm	0.71 in
Low	0.88 mm	0.035 in
Centrifugal Force @ 30.5 Hz (1830 vpm)		
Maximum	266 kN	59,800 lb
Minimum	133 kN	29,900 lb

Service Refill Capacities

Fuel Tank, total capacity	242 L	64 gal
Diesel Exhaust Fluid refill capacity	19 L	5 gal
Cooling System	27.4 L	7.2 gal
Engine Oil w/ Filter	8.8 L	2.3 gal
Eccentric Weight Housings (Combined)	26 L	6.9 gal
Axle and Final Drives	18 L	4.8 gal
Hydraulic Tank (service refill)	50 L	13.2 gal

Technical Specifications

Dimensions

1	Overall Length	5.9 m	19.2 ft
2	Overall Width	2.3 m	7.5 ft
3	Drum Width	2134 mm	84 in
4	Drum Shell Thickness	25 mm	1 in
5	Drum Diameter (oval pads)	1549 mm	60.9 in
	Drum Diameter (optional square pads)	1496 mm	58.7 in
6	Maximum Overall Height	3.1 m	10.2 ft
7	Wheelbase	2.9 m	9.5 ft
8	Ground Clearance	450 mm	17.7 in
9	Curb Clearance	551 mm	21.7 in
	Inside Turning Radius	3.7 m	12.1 ft
	Hitch Articulation Angle	34°	
	Hitch Oscillation Angle	15°	

Padfoot Specifications

Number of Pads	140	
Pad Height, oval pads	127 mm	5 in
Pad Face Area, oval pads	74.4 cm ²	11.5 in ²
Pad Height, optional square pads	100 mm	3.9 in
Pad Face Area, optional square pads	123 cm ²	19.1 in ²
Number of Chevrons	14	

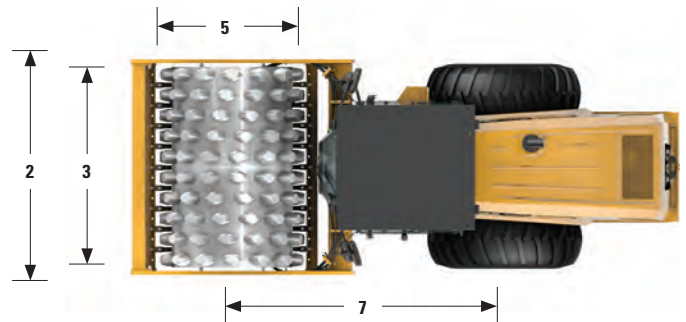
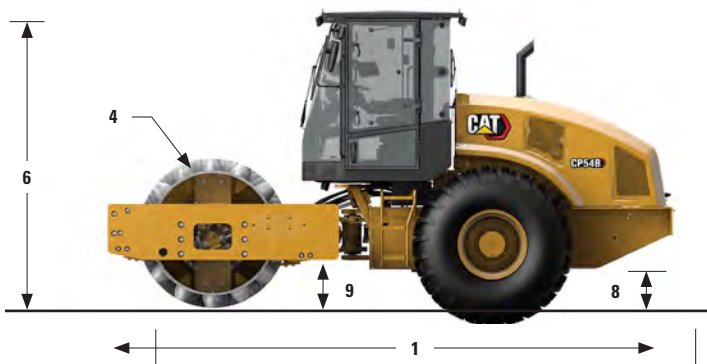

Cat® CP54B Vibratory Soil Compactor

Environmental Declaration

The following information applies to the machine at the time of final manufacture as configured for sale in the regions covered in this document. The content of this declaration is valid as of the date issued; however, content related to machine features and specifications are subject to change without notice. For additional information, please see the machine's Operation and Maintenance Manual.

For more information on sustainability in action and our progress, please visit www.caterpillar.com/en/company/sustainability.html.

ENGINE

- The Cat C4.4 is available in configurations that meet U.S. Tier 4 Final and EU Stage IV emissions standards.
- Cat diesel engines are required to use ULSD (ultra-low sulfur diesel fuel with 15 ppm of sulfur or less) or ULSD blended with the following lower-carbon intensity fuels up to:
 - ✓ 20% biodiesel FAME (fatty acid methyl ester)*
 - ✓ 100% renewable diesel, HVO (hydrogenated vegetable oil) and GTL (gas-to-liquid) fuels

Refer to guidelines for successful application. Please consult your Cat dealer or "Caterpillar Machine Fluids Recommendations" (SEBU6250) for details.

**Engines with no aftertreatment devices can use higher blends, up to 20% biodiesel.*

AIR CONDITIONING SYSTEM

The air conditioning system on this machine contains the fluorinated greenhouse gas refrigerant R134a (Global Warming Potential = 1430). The system contains 0.8 kg (1.8 lb) of refrigerant, which has a CO₂ equivalent of 1.144 metric tonnes (1.261 tons).

PAINT

- Based on best available knowledge, the maximum allowable concentration, measured in parts per million (PPM), of the following heavy metals in paint are:
 - Barium < 0.01%
 - Cadmium < 0.01%
 - Chromium < 0.01%
 - Lead < 0.01%

SOUND PERFORMANCE

With cooling fan speed at maximum value:

Exterior Sound Power Level (ISO 6395:2008) – 108 dB(A)

With cooling fan speed at 70% of maximum value:

Operator Sound Pressure Level (ISO 6396:2008) – 79 dB(A)

- When properly installed and maintained, the cab offered by Caterpillar, when tested with doors and windows closed according to ANSI/SAE J1166 OCT98, meets OSHA and MSHA requirements for operator sound exposure limits in effect at time of manufacture.
- Hearing protection may be needed when operating with an open operator station and cab (when not properly maintained or doors/windows open) for extended periods or in a noisy environment.

OILS AND FLUIDS

- Caterpillar factory fills with ethylene glycol coolants. Cat Diesel Engine Antifreeze/Coolant (DEAC) and Cat Extended Life Coolant (ELC) can be recycled. Consult your Cat dealer for more information.
- Cat BIO HYDO™ Advanced is an EU Ecolabel approved biodegradable hydraulic oil.
- Additional fluids are likely to be present, please consult the Operations and Maintenance Manual or the Application and Installation guide for complete fluid recommendations and maintenance intervals.

FEATURES AND TECHNOLOGY

- The following features and technology may contribute to fuel savings and/or carbon reduction. Features may vary. Consult your Cat dealer for details.
 - Standard eco-mode limits engine RPM, lowering overall fuel consumption compared to high idle
 - Optional compaction control reduces unnecessary passes, contributing to lower overall fuel consumption
 - Extended maintenance intervals reduce fluid and filter consumption
 - Auto idle shutdown reduces unproductive hours and fuel burned
 - Hydraulic on demand fan changes speed with temperature

Cat® CP54B Vibratory Soil Compactor

For more information on Cat products, dealer services, and industry solutions visit us on the web at www.cat.com.

© 2022 Caterpillar
All rights reserved.

Materials and specifications are subject to change without notice. Featured machines in photos may include additional equipment. See your Cat dealer for available options.

CAT, CATERPILLAR, LET'S DO THE WORK, their respective logos, "Caterpillar Corporate Yellow," the "Power Edge" and Cat "Modern Hex" trade dress as well as corporate and product identity used herein, are trademarks of Caterpillar and may not be used without permission.

QEHQ1557 (08-2022)
Build Number 01A

