



Cat[®] EL1000

LONGWALL SHEARER

Specifications

	Machine @ 50 Hz	Machine @ 60 Hz
Seam Range	1.6-3.9 m	63-156 in
Typical Machine Length (drum centers)	13 780 mm	45.25 ft
Installed Power	1230 kW	1,924 hp
Available Cutting Power	2 × 500 kW	2 × 805 hp
Cutting Drum Diameter	1500 to 2000 mm	61 to 79 in
Cutting Drum Speed	33.5, 38.8 and 43.8 rpm	40.2, 46.6 and 52.5 rpm
Haulage Control	AC inverter drive	AC inverter drive
Haulage Power	2 × 100 kW	2 × 134 hp
Haulage Speed (max.)	Up to 29.5 m/min	Up to 97 ft/min
Haulage Pull (max.)	Up to 622.3 kN	Up to 70 tons
Pump Motor	30 kW	48 hp
Body Height	550 mm	21.6 in
Machine Weight (approximate, depending on configuration)	60 tonnes	66 tons
Operating Voltage	3,300V	4,160V
Minimum Pan Width	832 mm	32.7 in

Ranging Arm – RA560

- Reconfigurable gear cassettes for adaptation of drum speeds
- Integral monitoring transducers
- Quillshaft transmission protection
- High-speed gears and idlers rated for 560 kW at 50Hz (900 hp at 60 Hz), hub rated for 750 kW at 50 Hz (1,200 hp at 60 Hz).
- Separate oil compartments for high speed and planetary section (optimal cooling and lubrication)
- Robust cowl drive mechanism (optional)
- Vibration monitoring (optional)

Haulage Unit – HU100

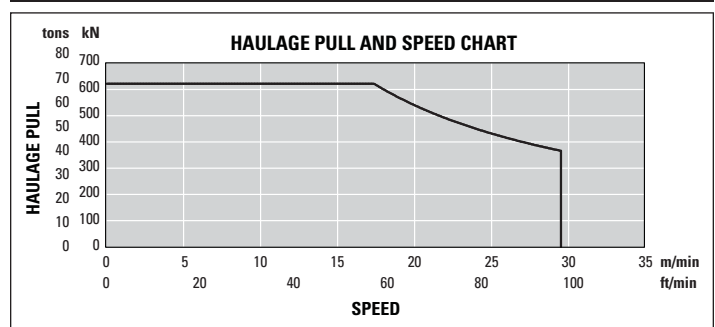

- Transmission reduction of 132.6:1
- Absolute encoder for accurate machine position detection (no reset devices at gate ends needed)
- Fast oil drain functionality
- Closed loop control for accurate load-sharing and increased service life of rackbar and sprocket
- Haulage unit accepts hydraulic motor for installation and face recovery
- Oil temperature monitoring
- Quill shaft transmission protection
- Machine parking brake (optional)
- Vibration monitoring (optional)

Downdrive – DD100

- Configurations for direct and indirect drives
- Fully removable, modular gearbox
- Removable modular top drive wheel assembly (top cover allows easy and quick inspections)
- Trapping shoe with replaceable wear inserts (for indirect drives)
- Suitable for all rack type systems
- Reconfigurable downdrive and shoe posts for different pan widths or seam heights

EL1000 Longwall Shearer

Powerpack – PP2

- Single powerpack with less parts to fail and less tasks for quick and easy maintenance
- Fixed displacement pump with two options:

	Capacity		Operating Pressure
	at 50 Hz	at 60 Hz	
Option 1	49 L/min (10.8 gal/min)	59 L/min (13 gal min)	280 bar (4,060 psi)
Option 2	62 L/min (13.6 gal/min)	74 L/min (16.3 gal/min)	225 bar (3,260 psi)

- Robust hydraulic reservoir of 140 L (37 gal) capacity
- Integral monitoring transducers (oil level and temperature)
- For use with ISO 68 hydraulic oils
- Available with 6 section valve bank
- Reliable low-voltage pump motor rating of 30 kW @ 50 Hz (48 hp @ 60 Hz)
- Optional boost valve for accelerated gate end operations (recommended for cowls)

Mainframe – MF1

- High structural integrity and absorption of all cutting and haulage forces, providing maximum protection for all major units
- Maximum protection of electrical boxes, providing the highest level of flameproof integrity, protects gearboxes against torsion
- Split mainframe available in case of transportation limitations
- Modular design enabling for selective overhauls
- Spray boom retrofittable
- Mainframe adds additional weight to cope with the most challenging cutting conditions

Electrical Control Box – ECB2

- Flameproof module containing the majority of the electrical control and power distribution components
- High current carrying capacity of 400 amps; accommodation of trailing cables up to 120 mm² (4/0 AWG)
- Internal chassis can be 'bench built,' tested and stored
- LV circuit breakers resettable through FLP cover (reduced downtime)
- Powerful PMC Evo-S control system with state-of-the-art Ethernet communication
- Containing cutter motor contactors, circuit breakers, control transformer, current monitoring, HV fuses, earth leakage and visible disconnect

Haulage Transformer Box – HTB2

- Flameproof module containing the main 253 kVA haulage transformer, power supplies, auxiliary transformer, drive system circuit breaker, hydraulic pump motor, and a 250 kW (335 hp) 600V AC inverter drive with integrated regenerative braking.

Electrical Material

- This model of shearer is available with headlights, cameras, methane monitoring, end displays and audible alarms.
- All electrical material is designed and certified to IEC standards and also complies with other regional and national standards, such as MSHA, GOST, MA, ATEX and DGMS, as well as Australia's New South Wales and Queensland regulations.

Hydraulic Material

- All Cat hose assemblies are designed according to ISO 6805 and proof tested according to EN ISO 1402.
- The hoses are assembled to Hose Assembly Standard DIN 20066.
- Hose selection and routing per industry standard best practices (including MDG41, ISO 17165-2 and SAE J1273)
- Cat hoses are aligned with the standards of MSHA, DGMS and MA

Water Circuit Material

- All Cat hose assemblies are designed according to ISO 6805 and proof tested according to EN ISO 1402.
- The hoses are assembled to Hose Assembly Standard DIN 20066.
- Hose selection and routing per industry standard best practices (including MDG41, ISO 17165-2 and SAE J1273).
- Cat hoses are aligned with the standards of MSHA, DGMS and MA
- Stainless steel fittings (optional)
- Onboard water filtration (optional)

Dust Suppression

- Wide range of dust suppression solutions available:
 - Body sprays
 - Spray booms
 - Sloughing plate sprays
 - Spray rings (in place of cowls)
 - Shearer clearers

Health Monitoring

- A comprehensive health monitoring system is available, including oil levels and temperatures, flows, pressures and vibration analysis.

Machine Automation and Communication

- Distributed, high-performance PMC-S control system for machine control, health monitoring, system protection and predictive maintenance
- Modular design allows individual configuration (from basic monitoring and protection to advanced automation) to meet customer requirements
- Fast Ethernet Broadband communication allows enhanced diagnostics and analysis
- Control system architecture with backup functionality
- Widespread use of intrinsically safe components for improved serviceability and maintenance
- Machine performance algorithm "advanced motor and speed control" for increased machine uptime, coal production and longer service life
- Shearer automation levels available:
 - Standard Machine Control
 - Basic Automation
 - Advanced Automation (including face alignment horizon control)
- Pan Angle Measurement System (PAMS) enabling fully automated gate end cutting sequences without machine operator interactions (optional)
- Horizon Control from PMC-R Controls to allow corrections to Floor and Roof drum cutting heights (optional)
- Shearer Remote Operation to allow machine control from a safe remote location outside the face (optional)

Remote Control

- Lightweight handheld device
- Color graphic display
- Tilt, drop and impact detection

EL1000 Longwall Shearer

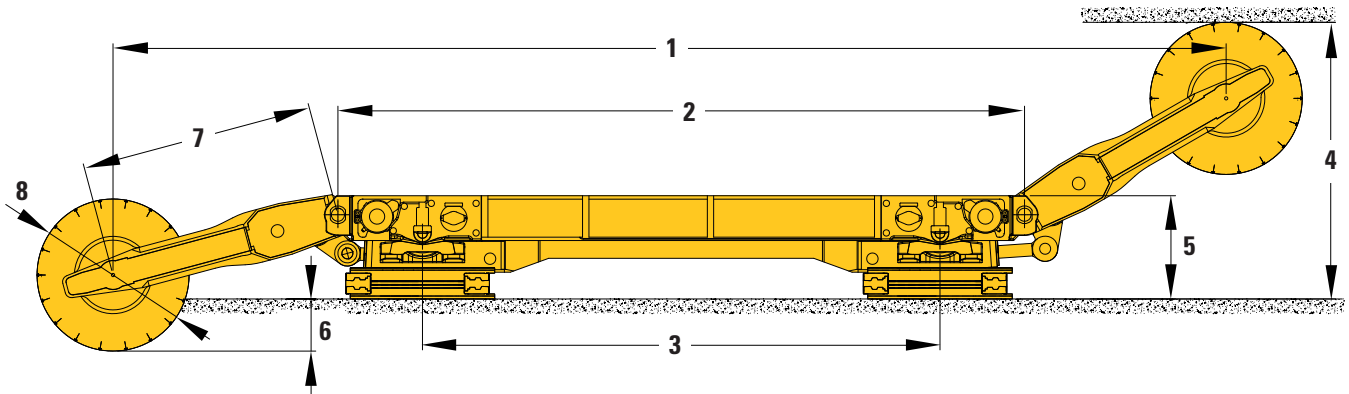

Dimensions (All dimensions are approximate)

	Low (DD)		Low (ID)		Mid-Low (ID)		High (DD)		High (ID)		
	mm	in	mm	in	mm	in	mm	in	mm	in	
1 Distance between Drums with Arms Horizontal	13 780	543	13 780	543	13 780	543	13 780	543	13 780	543	
2 Distance between Ranging Arm Hinge Points	8270	326	8270	326	8270	326	8270	326	8270	326	
3 Distance between Trapping Shoe Centers	6123	241	6199	244	6022	237	5530	218	5530	218	
4 Cutting Heights	Maximum	3580	141	3540	139	3785	149	3955	156	3965	156
	Minimum	1600	63	1600	63	2000	79	2200	87	2200	87
5 Height to Top of Machine Main Body	1220	48.0	1180	45.5	1300	51.2	1400	55.1	1410	55.5	
6 Shearer Drum Undercut of Floor	995	39	1035	41	1040	41	1030	41	1030	41	
7 Ranging Arm Length (hinge to drum)	2755	108	2755	108	2755	108	2755	108	2755	108	
8 Diameter of Shearer Cutting Drum	1550	61	1550	61	1800	71	2000	79	2000	79	

DD = Direct Drive

ID = Indirect Drive

NOTE: All illustrations and drawings are exemplary. Binding drawings are created for specific offers.

EL1000 Longwall Shearer

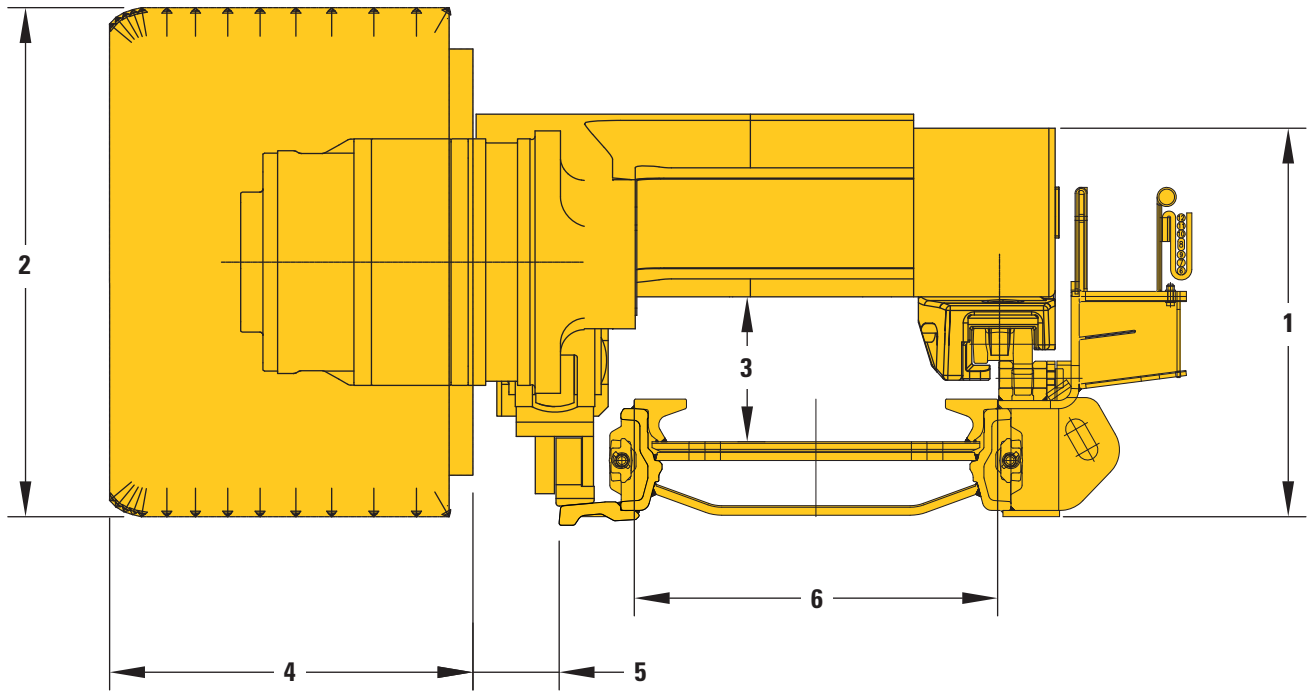

Dimensions (All dimensions are approximate)

Haulage Drive Type	Low (DD)		Low (ID)		Mid-Low (ID)		High (DD)		High (ID)		
	Direct Drive (DD)	In-Direct Drive (ID)	In-Direct Drive (ID)	In-Direct Drive (ID)	Direct Drive (DD)	In-Direct Drive (ID)	Direct Drive (DD)	In-Direct Drive (ID)	Direct Drive (DD)	In-Direct Drive (ID)	
1 Height to Top of Machine Main Body	1220 mm	48.0 in	1180 mm	45.5 in	1300 mm	51.2 in	1400 mm	55.1 in	1410 mm	55.5 in	
2 Diameter of Shearer Cutting Drum	1550 mm	61 in	1550 mm	61 in	1800 mm	71 in	2000 mm	79 in	2000 mm	79 in	
3 Vertical Tunnel Clearance	470 mm	18.5 in	430 mm	16.9 in	550 mm	21.7 in	650 mm	25.6 in	660 mm	26.0 in	
4 Maximum Cutting Drum Overall Width	1150 mm	45 in	1150 mm	45 in	1150 mm	45 in	1150 mm	45 in	1150 mm	45 in	
5 Clearance from Drum to AFC Toeplate	280 mm	11.0 in	280 mm	11.0 in	290 mm	11.4 in	290 mm	11.4 in	290 mm	11.4 in	
6 AFC Pan Width	Maximum	1342 mm	53 in	1342 mm	53 in	1342 mm	53 in	1342 mm	53 in	1342 mm	53 in
	Minimum	832 mm	33 in	1032 mm	41 in	1032 mm	41 in	832 mm	33 in	1032 mm	41 in

DD = Direct Drive

ID = Indirect Drive

NOTE: All illustrations and drawings are exemplary. Binding drawings are created for specific offers.

For more complete information on Cat products, dealer services, and industry solutions, visit us on the web at www.cat.com

© 2020 Caterpillar
All rights reserved

Materials and specifications are subject to change without notice. Featured machines in photos may include additional equipment. See your Cat dealer for available options.

CAT, CATERPILLAR, LET'S DO THE WORK, their respective logos, "Caterpillar Corporate Yellow," the "Power Edge" and Cat "Modern Hex" trade dress as well as corporate and product identity used herein, are trademarks of Caterpillar and may not be used without permission.

AEHQ6955-02 (05-2020)
Replaces AEHQ6955-01
(Global)

