

# 302.7D CR

Mini Hydraulic Excavator



#### Engine

Gross Power	17.9 kW	24.3 hp
Net Power*	15.2 kW	20.7 hp

#### Weight

Operating Weight with Cab	2830 kg	6,239 lb
---------------------------	---------	----------

\*Meets U.S. EPA Tier 4 Final/EU Stage V emission standards.



**Contents**

Compact Dimensions.....4

Performance and Durability.....5

User Friendly Operation.....6

Serviceability/Maintenance.....7

Customer Support.....8

Specifications.....9

302.7D CR Standard Equipment.....11

302.7D CR Optional Equipment.....11





## Compact Dimensions

Reduced damage – Operator confidence –  
Increased productivity



### Compact Radius

Configured without the additional counterweight the 302.7D CR is a true zero tail swing machine with the upper body staying within the width of the undercarriage during rotation. This enables the operator to work within confined areas and concentrate on the work being performed without having to worry about the back of the machine.



### Transport Weight

The 302.7D CR is designed with a transport weight below 2.7 tonnes (6,000 lb) with cab fitted.

This allows lower trailer transportation costs using a standard passenger vehicle (subject to national restrictions).



### Additional Counterweight

An optional additional weight increases the machines lifting capability with only a small addition to the overhang.

An optional additional counterweight increases the machines lifting capacity with only a small addition to the overhang.

(This counterweight is fitted as standard for North America and Australia)

# Performance and Durability

Powerful hydraulics – Robust construction –  
Work tool ready



## Auxiliary Hydraulics as Standard Fit

Machine is 'ready to work.' Hammer and two way lines complete with quick disconnect fittings are standard. Connections are located close to the tool to reduce hose lengths and any potential damage.

Additional lines options are available to further increase machine versatility.

Stick and bucket cylinder hoses are protected by routing them through the boom.

## 100% Pilot Controls

Delivers excellent machine control and lifetime 'as new' performance eliminating the need for linkage and cable maintenance.

## Automatic Swing Lock

Safe transportation of the machine is aided by the Cat automatic swing lock which locks the machines upper body in place when the control console is raised or the engine is stopped.

## Thumb Ready Stick (North American Builds)

Machine is configured with brackets and relief valves for simple and cost effective mounting of a hydraulic thumb.



## Dozer Float

Ground levelling and finishing applications are fast and easier with the dozer float function engaged making site clean-up much more efficient.

# User Friendly Operation

## Comfortable productivity

### Cab Comfort

The Cat® 302.7D CR gives the operator a large comfortable space in which to work. The ergonomic control layout, travel pedals and adjustable wrist rests are engineered to minimize operator fatigue and increase productivity.

### Simultaneous Operation

Both machine upper body swing and boom offset can be controlled simultaneously for faster machine positioning and object handling.

### Adjustable Flow Control

Machines configured with proportional auxiliary hydraulics include adjustable hydraulic flow control for even greater tool control. Especially useful with tools such as angling buckets.



### Split Front Window

The lower front window section slides into the upper section frame. Both sections are then raised and stored in the roof using a gas assisted mechanism.

This allows the operator to position the front window to suit their visibility and ventilation requirements with easy storage.



## Serviceability/Maintenance

Easy access for both maintenance and daily inspection

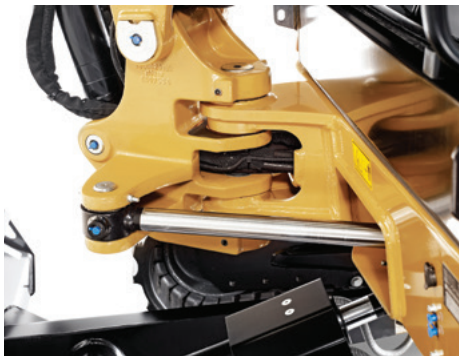

### Pivot Bushing

Steel bushings are fitted on all front linkage pivot points including the swing casting, boom, stick and bucket. Designed for long life and easy replacement.



### Maintenance Access

Removable covers in the cab and at the rear of the machine provide easy access to hydraulic system components.



### Side Mounted Engine

All daily service points are easily accessed through the large side cover. The engine position also reduces heat and noise transfer into the operator station (cab).

# Customer Support

Low operating costs with excellent services and options



## Customer Support

Product supported through the Cat dealer and worldwide parts network aimed at minimizing downtime.

- Finance options
- Warranty options
- Maintenance contracts

Help and advice in product and option selection to maximize efficiency and operating profitability

## Work Tools

A range of tools is available to take advantage of the machines versatility. All tools are matched to the machine to optimize performance and deliver excellent value through high productivity and long life.





# 302.7D CR Mini Hydraulic Excavator Specifications

## Engine

Engine Model	Yanmar 3TNV76	
Rated Net Power (ISO 9249)	15.2 kW	20.7 hp
Gross Power	17.9 kW	24.3 hp
Displacement	1115 cm <sup>3</sup>	68 in <sup>3</sup>

- Engine meets Tier 4 Final Stage V emission standards.

## Weight

Operating Weight with Cab	2830 kg	6,239 lb
Operating Weight with Canopy	2737 kg	6,034 lb

## Travel System

Travel Speed	2.1 km/h/	1.30 mph/
	3.8 km/h	2.36 mph
Gradeability	30°/58%	

## Service Refill Capacities

Fuel Tank Capacity	35.2 L	9.3 gal
Hydraulic Tank Capacity	26.5 L	7 gal

## Blade

Width	1570 mm	61.9 in
Height	290 mm	11.4 in
Dig Depth	419 mm	16.5 in
Lift Height	380 mm	15 in

## Hydraulic System

Pump Flow @ 2,500 rpm	89.4 L/min	23.6 gal
Operating Pressure – Equipment	225 bar	3,263 psi
Operating Pressure – Travel	225 bar	3,263 psi
Operating Pressure – Swing	206 bar	2,987 psi
Auxiliary Circuits		
Primary	52.2 L/min at 225 bar (13.8 gal/min at 3,263 psi)	
Secondary	30.8 L/min at 206 bar (8.1 gal/min at 2,988 psi)	
Maximum Bucket Force	22.5 kN	5,058 lbf
Maximum Stick Force Standard/Long	15.4 kN/ 13.6 kN	3,462 lbf/ 3,057 lbf

## Lift Capacity at Ground Level with Cab

Lift Point Radius	2.5 m (98.43 in)				3.0 m (118.11 in)				3.5 m (137.80 in)				Maximum			
	Blade Down								Blade Down							
	Front		Side		Front		Side		Front		Side		Front		Side	
	kg	lb	kg	lb	kg	lb	kg	lb	kg	lb	kg	lb	kg	lb	kg	lb
Standard Stick	992*	2,187	456	1,005	750*	1,654	351	774	597*	1,316	283	623	517*	1,141	252	556
Long Stick and Optional Counterweight	985*	2,172	521	1,149	739*	1,630	402	886	591*	1,303	322	711	478*	1,054	267	588

\* The above loads are in compliance with hydraulic excavator lift capacity rating standard ISO 10567:2007 and they do not exceed 87% of hydraulic lifting capacity or 75% of tipping capacity. The excavator bucket weight is not included on this chart.

# 302.7D CR Mini Hydraulic Excavator Specifications

## Dimensions

All dimensions are approximate.

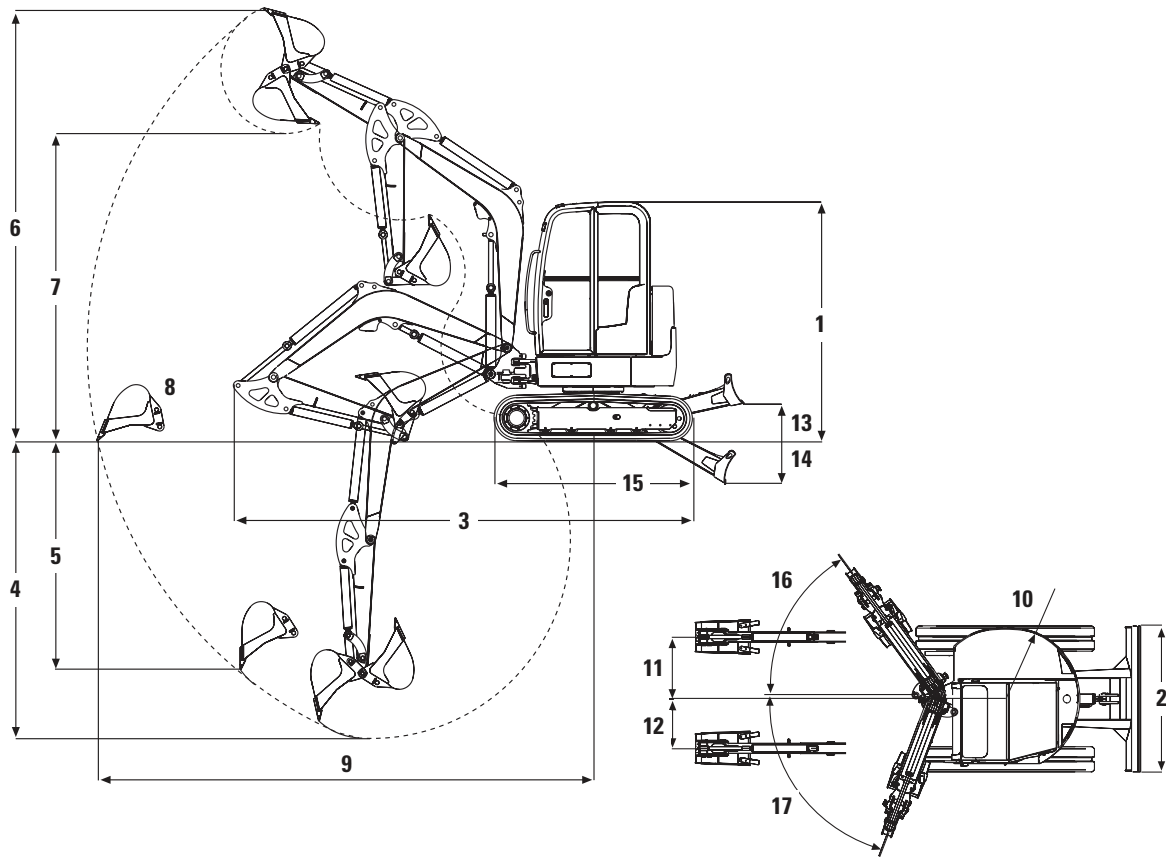

	Standard Stick		Long Stick	
<b>1</b> Height	2408 mm	7'11"	2408 mm	7'11"
<b>2</b> Width	1570 mm	5'2"	1570 mm	5'2"
<b>3</b> Transport Length (arm lowered)	4255 mm	14'0"	4255 mm	14'0"
<b>4</b> Maximum Digging Depth	2544 mm	8'4"	2744 mm	9'0"
<b>5</b> Maximum Vertical Dig Depth	1962 mm	6'5"	2152 mm	7'1"
<b>6</b> Maximum Dig Height	4170 mm	13'8"	4300 mm	14'1"
<b>7</b> Maximum Dump Height	2840 mm	9'4"	2970 mm	9'8"
<b>8</b> Maximum Reach	4613 mm	15'1"	4805 mm	15'10"
<b>9</b> Maximum Reach at Ground Level	4481 mm	14'8"	4681 mm	15'5"
<b>10</b> Tail Swing Radius	760 mm	30"	760 mm	30"
<b>11</b> Track Width	764 mm	30"	764 mm	30"
<b>12</b> Minimum Front Linkage Swing Radius	533 mm	21"	533 mm	21"
<b>13</b> Maximum Dozer Lift Height	380 mm	15"	380 mm	15"
<b>14</b> Maximum Dozer Dig Depth	419 mm	16"	419 mm	16"
<b>15</b> Length of Undercarriage	2006 mm	79"	2006 mm	79"
<b>16</b> Boom Swing Angle (right)	50°		50°	
<b>17</b> Boom Swing Angle (left)	75°		75°	

## 302.7D CR Standard Equipment

### Standard Equipment

Standard equipment may vary. Consult your Cat dealer for details.

- 1-way and 2-way (combined function) auxiliary hydraulic lines
- 300 mm rubber track
- Canopy with Tip Over Protection (TOPS) ISO 12117
- Dozer blade with float function
- Hydraulic oil cooler
- Maintenance free battery
- Retractable seat belt
- Suspension seat, vinyl covered
- Travel pedals
- Working light mounted to boom

## 302.7D CR Optional Equipment

### Optional Equipment

Optional equipment may vary. Consult your Cat dealer for details.

- Additional hydraulic circuit diverted from bucket cylinder
- Auto idle (Standard in North America)
- Bio oil
- Boom check valve
- Cab, radio ready with FOPS ISO 10262 (Level 1), Tip Over Protection (TOPS) ISO 12117, heater/defroster, interior light and windscreen wiper
- Custom color paint
- Ecology drain for engine oil
- Ecology drain for hydraulic tank
- Front screen guard for cab and canopy
- Joystick mounted proportional auxiliary control
- Mechanical quick coupler
- Mirror pack
- Rotating beacon
- Suspension seat, fabric covered
- Thumb ready stick (Standard in North America)

For more complete information on Cat products, dealer services, and industry solutions, visit us on the web at [www.cat.com](http://www.cat.com)

AEHQ6207-07 (05-2020)  
Replaces AEHQ6207-06

© 2020 Caterpillar  
All rights reserved

Materials and specifications are subject to change without notice. Featured machines in photos may include additional equipment. See your Cat dealer for available options.

CAT, CATERPILLAR, LET'S DO THE WORK, their respective logos, "Caterpillar Corporate Yellow," the "Power Edge" and Cat "Modern Hex" trade dress as well as corporate and product identity used herein, are trademarks of Caterpillar and may not be used without permission.

