



Cat[®] Pickup Brooms

WHEEL LOADERS
BACKHOE LOADERS

FEATURES:

Sweeping Versatility

- Cat Pickup Brooms sweep and deposit materials into an integrated hopper for easy removal and dumping of debris.
- Built for use on Wheel Loaders, Integrated Tool Carriers and Backhoe Loaders.

Integrated, Easy to Empty Hopper

- Pickup Brooms include a large hopper for greater productivity and easy removal and emptying.

Durable, Reliable Design

- Motors are protected from dust and debris—yet easily accessible.
- Caterpillar XT[™]-3 ES hoses, couplings and o-ring face seals provide superior leak free performance and reliability. All hoses are wrapped with nylon woven Codura sleeving for added operator protection.
- Broom bearings are maintenance-free for long life.

Unique Suspension System

- A unique suspension system eliminates the need for support wheels. Brush maintains constant ground pressure through a range of vertical motion from the initial setting.
- Parking supports provide stable and secure parking of the broom.

Practical, Convenient Brush Elements

- Brush bristles are made with polypropylene for durability and long brush life.
- When required, brush elements are quickly and easily replaced.

Pickup Broom/Wheel Loader and Backhoe Loader Compatibility

Recommended machine matches. Contact your local Cat Dealer for more detailed matching information.

Model	Machines
BP22	902, 906, 908
BP25	924, 928, 930, IT14, IT28, 416, 420, 430, 446, 450

Cat Pickup Brooms

Pickup Broom Specifications

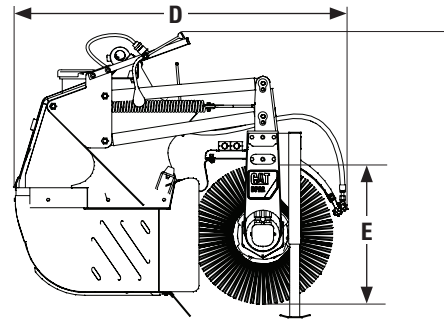
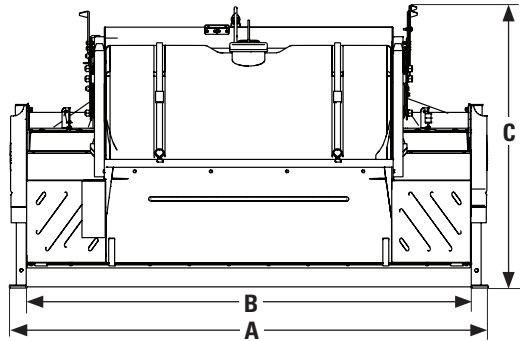

			BP22		BP25	
Weight (Hydraulic Angle)	kg	(lb)	560	(1235)	651	(1435)
A Overall Width	mm	(in)	2400	(94.5)	2700	(106.3)
B Sweeping Width	mm	(in)	2200	(86.6)	2500	(98.4)
C Height	mm	(in)	1300	(51.2)	1500	(59.1)
D Length	mm	(in)	1700	(67)	1800	(70.9)
E Brush Diameter	mm	(in)	700	(27.5)	700	(27.5)
Water Capacity (optional)	L	(gal)	400	(100)	400	(100)
Hopper Capacity (struck)	m ³	(yd ³)	0.36	(0.47)	0.68	(0.89)
Optimal Working Speed	kph	(mph)	4–19	(2.5–12)	4–19	(2.5–12)

For more complete information on Cat products, dealer services, and industry solutions, visit us on the web at www.cat.com

GEHQ0184-01 (07-11)

Replaces GEHQ0184

©2011 Caterpillar
All Rights Reserved
Printed in U.S.A.

Materials and specifications are subject to change without notice. Featured machines in photos may include additional equipment. See your Cat dealer for available options.

CAT, CATERPILLAR, their respective logos, "Caterpillar Yellow," and the POWER EDGE trade dress, as well as corporate and product identity used herein, are trademarks of Caterpillar and may not be used without permission.

