

572R2

Pipelayer



Engine

Engine Model	Cat® 3176C	
Net Power – ISO 9249	179 kW	240 hp
Net Power – ISO 9249 (Metric)		243 hp

Weights

Operating Weight	32 342 kg	71,302 lb
Lift Capacity		
Lift Capacity at Tipping Point	40 800 kg	90,000 lb

572R2 Pipelayer Features

Performance

Rugged, durable components that are integrated into the machine design give you smooth, responsive power and lasting reliability.

Lift Capacity

The 572R2 gives you a lifting capacity of 40 800 kg (90,000 lb) to help you handle the heavy jobs.

Operator Comfort

An ergonomically designed operator station and fingertip controls help your operators work more comfortably and efficiently. We designed the machine to offer excellent views to the work area for greater productivity and enhanced job site safety.

Safety

The standard Roll Over Protection Structure (ROPS) helps provide additional safety for your operators. Good sight lines, a counterweight control and a convenient access ladder also contribute to overall job site safety.

Serviceability

Modular component design, Product Link™ monitoring and a machine that is designed for easy maintenance help you spend more time working on the right-of-way and less time in the service bay.

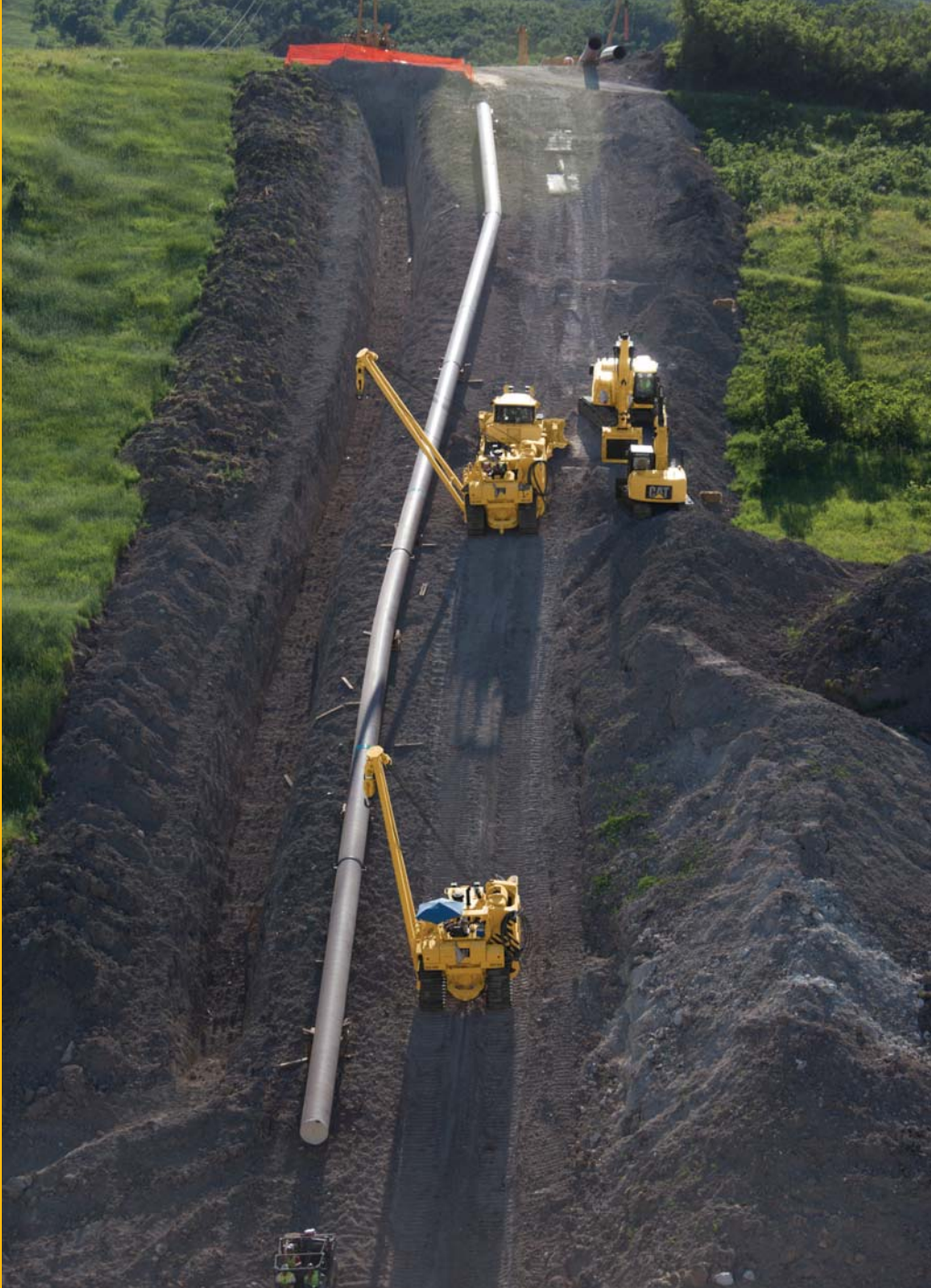

Contents

Pipelayer.....	3
Operator Station and Controls.....	4
Engine and Power Train.....	5
Structure.....	6
Undercarriage.....	6
Integrated Technologies.....	7
Sustainability.....	7
Serviceability.....	8
Safety.....	9
Renowned Cat Dealer Support.....	9
572R2 Specifications.....	10
572R2 Standard Equipment.....	13
572R2 Optional Equipment.....	14

Cat Pipelayers have been the standard of the pipeline industry for decades. A worldwide network of Cat dealers, in tune with the special high production needs of pipeliners, supports these durable and dependable machines. Cat Pipelayers are purpose-built to meet the unique demands of pipeline customers. And like every Cat machine, pipelayers are designed for long life, serviceability and rebuild capability to help keep owning and operating costs low.

Pipelayer

Integrated, robust components

Winches

Independent hydraulic winches drive boom and hook draw works. The oil-disc brakes give you smooth operation, as well as positive retention of the boom and hook positions. Infinitely variable speed controls give your operator precise control, and a free-fall function allows your operator to drop the load quickly in the event of an emergency.

Counterweight

A narrow profile of the counterweight design helps give your operators a better view around the machine. The box section frame, welded to a cast bevel gear case gives you a rugged mainframe design. The counterweight is extended hydraulically for better load balance and a service latch mechanically locks the counterweight in an extended position.

Boom

The tubular cast steel boom is rugged to give you better fatigue life. Replaceable boom-mount bearings aid serviceability and long life. Your choice of a standard 6.10 m (20 ft) boom, or an optional 7.3 m (24 ft) boom, means you can equip the machine to best suit the demands of your operation.

Blocks and Hook

The heavy-lifting, robust design is popular all around the pipeline industry. A counterweight latch gives you an added level of safety for servicing or inspection.

Drawbar

A robust drawbar tows a wide range of attachments for maximum versatility.





Operator Station and Controls

Designed for Productive Comfort

Caterpillar designs operator stations for maximum productivity. Easy-to-use controls and operator comfort features, along with excellent visibility all around the machine not only help operators work more efficiently, but also contribute to enhanced job site safety.

- The standard Roll Over Protection Structure (ROPS) provides increased operator protection.
- Ergonomically designed seat is fully adjustable for maximum comfort. It is designed to give your operator excellent support, while still allowing unrestricted arm and leg movement. The position of the seat is well matched to key operator control levers and pedals. Foot pads help provide added stability when working on slopes.
- Finger Tip Controls put steering, machine direction, and gear selection into one easy-to-use control. Low-effort pipelayer controls give your operator simultaneous, precise positioning of the load line and boom in one hand.
- The instrument panel is easy to read, even in direct sunlight.
- An in-dash monitoring system provides the operator with instant feedback on fluid levels and temperatures, as well as the condition of key machine operating systems. The system performs a self-test at every start and provides fault codes for easy troubleshooting.
- A standard 12-volt converter supplies power for devices like cell phones and laptop computers.
- A convenient access ladder gives your operator direct access/egress to the operator station.

Engine and Power Train

Powerful Efficiency

Engine

The Cat 3176C engine gives you the large displacement and good cold start capabilities needed on challenging jobs. Its durable design has been proven in some of the world's most challenging conditions and will provide years of dependable service.

Planetary Power Shift Transmission

The electronically controlled planetary power shift transmission offers smooth shifting and agile speed and directional changes for maximum productivity. With three speeds forward and three speeds reverse, the transmission utilizes large diameter, high capacity, oil-cooled clutches for long life. Forced oil flow lubricates and cools clutch packs for long life.

Electronic Clutch and Brake Steering System

Low-effort finger tip levers make steering easy and allow your operator to work more precisely in close areas and narrow right-of-ways.

Steering Clutch and Brakes

Oil cooled, hydraulically actuated, large diameter plates and clutch discs provide higher torque capacity and increased service life.

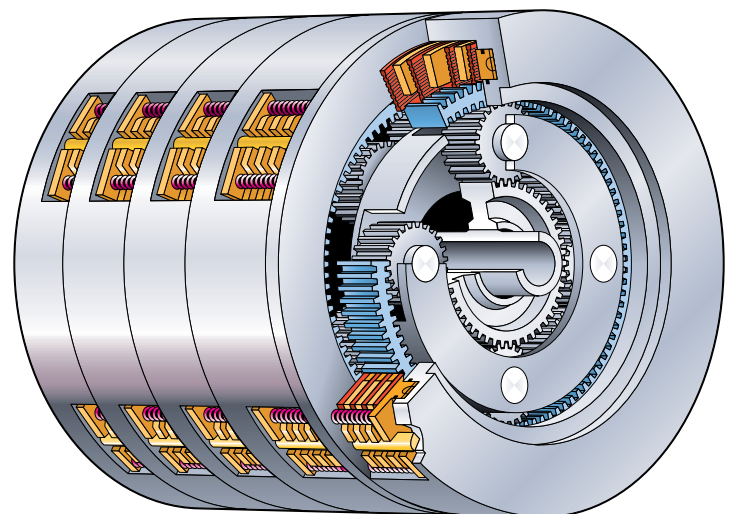
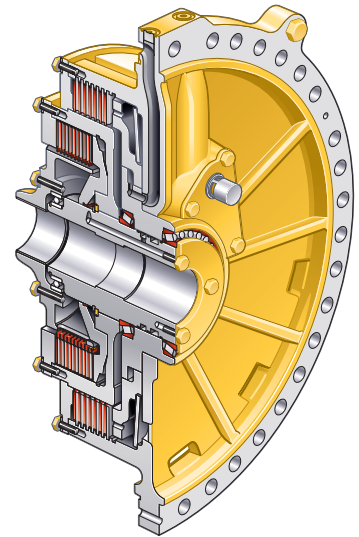
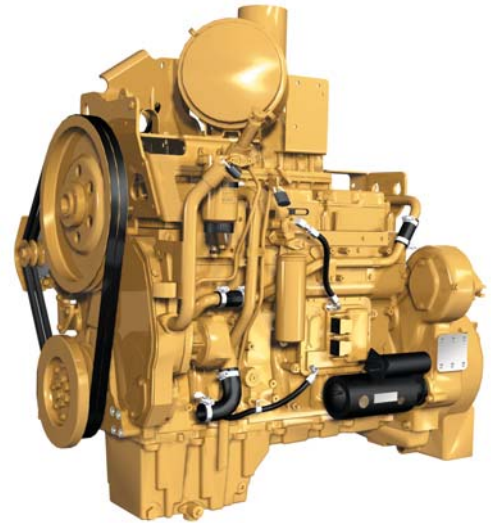

Structure

Underlying Strength

The Pipelayer main frame is engineered to handle the most demanding applications. The mainframe is built to absorb high impact shock loads and twisting forces. The one-piece all-welded chassis provides superior strength over bolted designs, as well as an optimum structure for pipelayer mounting. Heavy steel castings add strength to the main case, center saddle and front cross member for outstanding durability. The final drives are elevated well above the ground level work area to protect them from impact loads, abrasion and contaminants.

Caterpillar uses robotic welding techniques in the assembly of the case and frames. The deep penetration and consistency of robotic welding insures quality for long life and durability.



Undercarriage

Engineered for Performance

The 572R2 features a rigid Cat elevated sprocket undercarriage that isolates the final drives away from abrasive conditions. A long track roller frame and wide gauge give you more track contact area for a very stable working base.

Undercarriage components are built for long life and ease of serviceability. Rollers and idlers feature Duo-Cone™ seals to help prevent oil loss and dirt entry. Tubular roller frames resist bending and twisting, with added reinforcement where operating loads are highest. Cat sprocket segments are precision machined after heat treat for proper fit. Segments can be removed or replaced without breaking the track.

Pipelayer track is designed for high-impact and high load applications. The Heavy-Duty Sealed and Lubricated Track permanently coats the track pin with a sealed-in lubricant. This minimizes metal-to-metal contact and virtually eliminates internal pin and bushing wear.

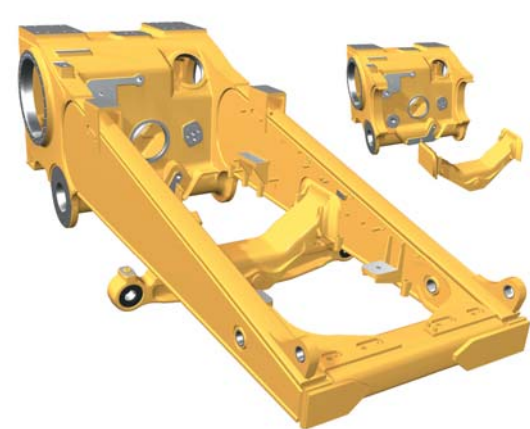

Integrated Technologies

Solutions to Make Work Easier and More Efficient



Cat Product Link™*

Remote monitoring with Product Link improves overall fleet management effectiveness. Product Link is deeply integrated into machine systems. Events and diagnostic codes, as well as hours, fuel, idle time and other detailed information are transmitted to a secure web based application, VisionLink®. VisionLink includes powerful tools to convey information to users and dealers, including mapping, working and idle time, fuel level and more.

**Product Link licensing not available in all areas.*

Sustainability

Thinking Generations Ahead

- Technologies like Product Link help improve overall efficiency, save fuel and fluids, and reduce equipment wear and tear.
- Convenient access ladder, excellent visibility and easy-to-use controls enhance job site safety.
- Ecology drains make draining fluids more convenient and help prevent spills.
- Major components are built to be rebuilt, eliminating waste and saving customers money by giving the machine and/or major components a second – and even third – life.



Serviceability

More Productivity, Less Cost



Modular Design

Major components are designed as modules and most can be removed without disturbing or removing other components. This means less service time and more working time for you.

Easy Diagnostics

The machine monitoring system provides instant feedback on the condition of operating systems, utilizing a three level warning system. The system can easily be upgraded by flashing software.

Service Access

Major service points are grouped to make your regular maintenance quicker and easier. Large service panel doors provide easier access to all maintenance locations.

Scheduled Oil Sampling (S-O-SSM) Analysis

Monitor machine health and identify key maintenance needs before they lead to downtime through Cat Scheduled Oil Sampling. Cat machines feature live sampling ports for the engine oil, power train hydraulics and coolant. Cat oil sampling offers accurate analysis using tests designed by Caterpillar for Cat products, as well as knowledgeable interpretation of the results.

Ecology Drains

Ecology drains provide a convenient method for draining fluids that saves time and helps prevent spills.



Safety

Designed with Protection in Mind

Job site safety is a key concern for pipeline customers, and Cat pipelayers are designed with features to help protect people in and around the machine.

- The standard Roll Over Protective Structure (ROPS) provides increased operator protection.
- The winch profile and overall machine design allow for excellent visibility around the machine.
- A long track roller frame and wide gauge give you more track contact area for a very stable working base.
- A left-side access ladder provides convenient access/egress to the operator station.
- A free-fall function allows your operator to drop the load quickly in the event of an emergency.



Renowned Cat Dealer Support

When Uptime Counts

Cat dealers excel at providing parts availability and equipment service to even the most remote areas. With more than 10,000 service technicians employed in over 3,000 Cat dealer locations around the world, Caterpillar parts and service resources and capabilities are beyond compare.

From helping you choose the right machine to knowledgeable ongoing support, Cat dealers provide the best in sales and service. Manage costs with preventive maintenance programs like Custom Track Service, Scheduled Oil Sampling (S·O·S) analysis, and guaranteed maintenance contracts. Stay productive with best-in-class parts availability. Cat dealers can even help you with operator training to help you boost your profits.

And when it's time for machine replacement, your Cat dealer can help you save even more with Genuine Cat Reman parts. Receive the same warranty and reliability as new products at cost savings of 40 to 70 percent for power train and hydraulic components.



572R2 Specifications

Engine

Engine Model	Cat 3176C	
Gross Power	192 kW	258 hp
Gross Power (Metric)	261 hp	
Gross Power – ISO 14396	189 kW	253 hp
Gross Power – ISO 14396 (Metric)	257 hp	
Rated Flywheel Power	179 kW	240 hp
Rated Flywheel Power (Metric)	243 hp	
Net Power – ISO 9249	179 kW	240 hp
Net Power – ISO 9249 (Metric)	243 hp	
Net Power – EEC 80/1269	179 kW	240 hp
Net Power – EEC 80/1269 (Metric)	243 hp	
Net Power – SAE J1349	177 kW	238 hp
Net Power – SAE J1349 (Metric)	241 hp	
Bore	125 mm	4.9 in
Stroke	140 mm	5.5 in
Displacement	10.3 L	629 in ³

- Engine Ratings at 2,100 rpm.
- Meets non-current U.S. EPA Tier 2 and EU Stage II emission standards.
- Net power advertised is the power available at the flywheel when the engine is equipped with fan, air cleaner, muffler, and alternator.
- No derating required up to 2286 m (7,500 ft) altitude, beyond 2286 m (7,500 ft) automatic derating occurs.

Transmission

1 Forward	3.52 km/h	2.19 mph
2 Forward	6.1 km/h	3.79 mph
3 Forward	10.54 km/h	6.55 mph
1 Reverse	4.54 km/h	2.82 mph
2 Reverse	7.85 km/h	4.88 mph
3 Reverse	13.58 km/h	8.44 mph

Undercarriage

Number of Shoes (each side)	43	
Track Rollers (each side)	7	
Track Gauge	2235 mm	88 in
Track on Ground	3176 mm	125 in
Track Shoe Width	660 mm	26 in
Ground Contact Area	4.19 m ²	6,500 in ²
Ground Pressure	74.46 kPa	10.8 psi

Weights

Operating Weight	32 342 kg	71,302 lb
Shipping Weight	31 347 kg	69,108 lb

- Operating Weight: Includes lubricants, coolant, 100% fuel, hydraulic controls and fluids, track, ROPS, drawbar, counterweight, boom and pulley blocks, and operator.
- Shipping Weight: Includes lubricants, coolant, 10% fuel, hydraulic controls and fluids, track, ROPS, drawbar, and counterweight.

Pipelaying Equipment

Lift Capacity at Tipping Point	40 800 kg	90,000 lb
Boom Length	6.1 m	20 ft
Hook Winch Drum Diameter	254 mm	10 in
Rope Minimum Breaking Strength	261.66 kN	58,800 lbf
Boom Winch Drum Diameter	224 mm	8.5 in
Hook Winch Flange Diameter	457 mm	18 in
Boom Winch Flange Diameter	406 mm	16 in
Hook Winch Drum Length	279 mm	11 in
Boom Winch Drum Length	254 mm	10 in
Diameter – Wire Rope	19 mm	0.75 in
Hook Winch Capacity – 19 mm (3/4 in) Diameter	80.16 m	263 ft
Boom Winch Capacity – 19 mm (3/4 in) Diameter	51.82 m	170 ft
Hook w/Wire Rope Installed – 19 mm (3/4 in) Diameter	50.29 m	165 ft
Boom w/Wire Rope Installed – 19 mm (3/4 in) Diameter	40.23 m	132 ft
Boom Line Speed	73 m/min	241 ft/min
4 Part Line Hook Speed (Lo)	11 m/min	36 ft/min
4 Part Line Hook Speed (Hi)	22 m/min	75 ft/min
Removable Counterweights		
Number of Segments	4	
2 at	370 kg	815 lb
1 at	1438 kg	3,170 lb
1 at	1918 kg	4,228 lb
Total 4 Segments	4096 kg	9,030 lb
Total Weight Extendible	5080 kg	11,200 lb

Hydraulic Controls

Type	Pressure compensating piston-type pump.	
Output – Maximum	281 L/min	74.2 gal/min
Relief Valve Setting – Counterweight	17 240 kPa 2,500 psi	
Relief Valve Setting – Hook and Boom Winch	33 000 kPa 4,786 psi	

- Pump output at 2,231 rpm (2,100 engine rpm) and maximum pressure at 7000 kPa (1,015 psi).

Service Capacities

Fuel Tank	479 L	126.5 gal
Crankcase (with Filter)	31 L	8.2 gal
Transmission, Bevel Gear, and Steering Clutch	183 L	48.3 gal
Final Drives (each)	13 L	3.4 gal
Cooling System	77.4 L	20.4 gal
Hydraulic Tank	54.1 L	14.3 gal
Recoil Spring Compartments (each)	57 L	15 gal

Standards

- Brakes meet the standard SAE J/ISO 10265:2008.
- ROPS (Rollover Protection Structure) offered by Caterpillar for the machine meets the criteria of ISO 3471:2008, ISO 3449:2005 Level II.

Lifting Capacity

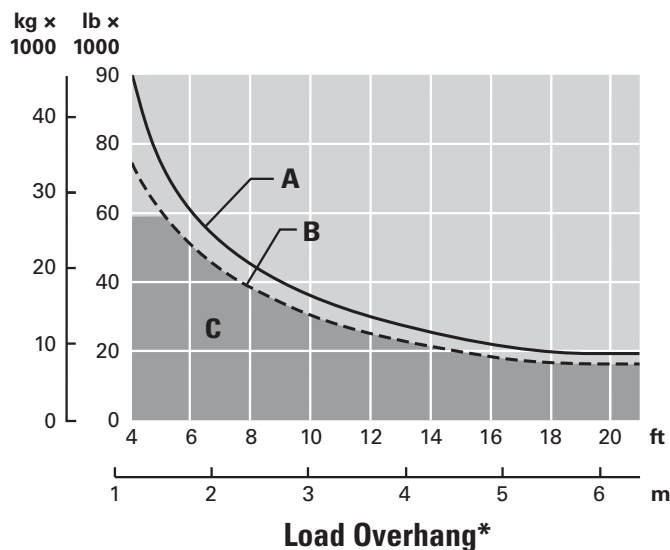

Specified Equipment

• Diameter wire rope	19 mm	0.75 in
• Rope minimum breaking strength	261.66 kN	58,800 lbf
• 4 part load line		
• 4 part boom line		
• Counterweight extended	5073 kg	11,184 lb
• Standard boom	6.10 m	20 ft
• Total operating weight	32 342 kg	71,302 lb

A Lift capacity at tipping point*

B Rated load capacity*

C Working range*

* Per ISO 8813:1992

572R2 Specifications

572R2 Dimensions

All dimensions are approximate.

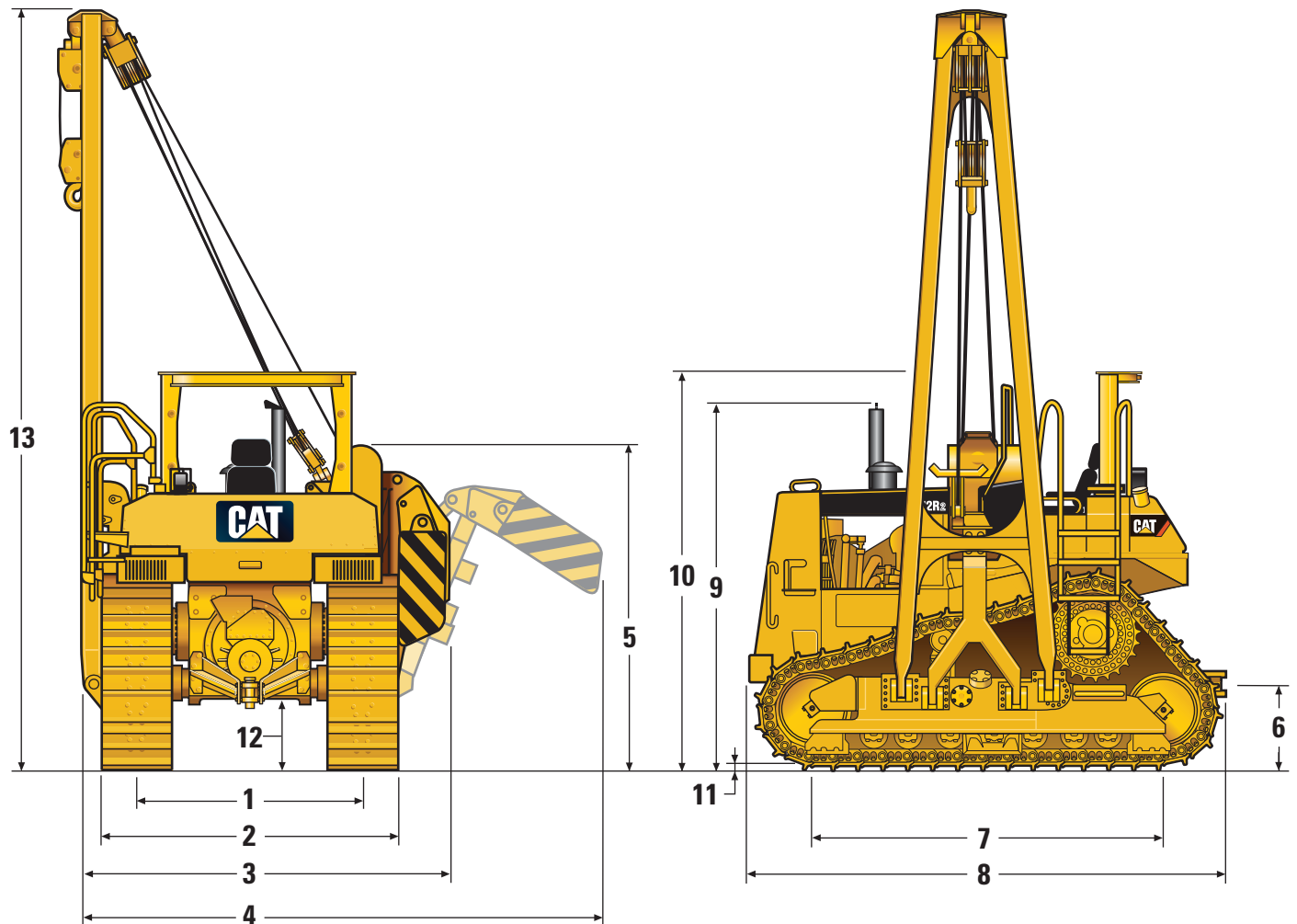

1	Track gauge	2235 mm	88 in
2	Width of tractor	2895 mm	114 in
3	Width of tractor (boom removed)	3659 mm	144 in
4	Width of tractor (counterweight extended)	5228 mm	206 in
5	Machine height (tip of grouser to top of winch)	2895 mm	114 in
6	Drawbar height (center of clevis)	634 mm	24.9 in
7	Length of track on ground	3176 mm	125 in
8	Operating length (with drawbar)	4736 mm	186 in
9	Height to top of stack	3387 mm	133 in
10	Machine height (tip of grouser to top of ROPS)	3450 mm	136 in
11	Grouser height	71 mm	2.8 in
12	Ground clearance (SAE J1234)	416 mm	16.4 in
13	Boom height (tip of grouser at SAE 1.22 m [4 ft] overhang)	6728 mm	265 in

Standard Equipment

Standard equipment may vary. Consult your Cat dealer for details.

ELECTRICAL

- Alarm, back-up
- Alternator, 70-amp
- Converter, 10-amp/12-volt
- Diagnostic connector (starting and charging)
- Horn, forward warning
- Hour meter
- Lights, 2 forward, 2 rear
- Starting receptacle, 24-volt direct

OPERATOR ENVIRONMENT

- Armrests, adjustable
- Brake pedal
- Decelerator pedal and switch
- Engine air cleaner service indicator
- Engine RPM display/gear display
- Foot pegs for slope work
- FTC control for Clutch and Brake steering
- Monitoring System, Electronic (EMS III) coolant temperature, power train oil, hydraulic and fuel gauge, tachometer, odometer, gear indicator diagnostic functions
- Power points, two 12-volt
- Pre-start coolant level monitoring system
- Product Link Ready
- ROPS, rollover protection system
- Seat, vinyl suspension
- Seat belt, retractable 76 mm (3 in)
- Storage and literature compartment
- Transmission shift points selection
- Travel speed and gear limiter, electronic

PIPELAYER

- Block and hook with latch
- Boom, 6.10 m (20 ft)
- Counterweight, extendible segmented 4096 kg (9,030 lb)
- Hydraulics, pipelayer system

UNDERCARRIAGE

- Adjuster, hydraulic track
- Carrier rollers
- Heavy-duty sealed and lubricated tracks
- Lifetime lubricated idlers and track rollers
- Master link, two-piece
- Sprockets, segmented
- Track frame, 7 rollers
- Track with single grouser track shoes
 - 43-section, 660 mm (26 in)

POWER TRAIN

- 3176C EUI Caterpillar diesel engine with:
 - Advanced Modular Cooling System (AMOCS)
 - Brake system, service, parking and emergency
 - Coolant, extended life
 - Drains, ecology (engine oil, coolant, hydraulic oil, fuel tank, power train case)
 - Fan, blower
 - Final drives, 3-planet double reduction planetary
 - Fuel priming pump
 - Fuel/Water separator
 - Grid, radiator core sand blast
 - Muffler
 - Precleaner with strata tube dust ejector
 - Prescreener
 - Starting aide, ether
 - Shifting, auto-shift (2F/2R, 2F/1R, 1F/2R)
 - Shifting, auto-kickdown (auto downshift)
 - Shifting, controlled throttle
 - Steering system, FTC Clutch and Brake
 - Torque divider
 - Transmission, power shift, three-speed planetary with torque converter

OTHER STANDARD EQUIPMENT

- Altitude operation capability, 2286 meter (7,500 ft) without derating
- Bumper, front with towing device
- Diagnostic pressure taps, centralized ecology drains
- Extended service intervals (500 hours)
- Guards:
 - Crankcase, normal service
 - End track-guide
 - Hinged bottom
 - Instrument panel
 - Radiator, hinged
 - Rear
- Hood, perforated
- Implement oil filter
- Keyed lockable enclosures
- Load sensing hydraulics
- Radiator doors, louvered, hinged
- Rigid drawbar
- S•O•S analysis taps for engine, transmission, and implement fluids
- Transmission remote pressure taps
- Vandalism protection

572R2 Optional Equipment

Optional Equipment

Optional equipment may vary. Consult your Cat dealer for details.

OPERATOR ENVIRONMENT

- Product Link PL321, none
- Product Link PL321, Satellite

PIPELAYER

- Boom, 7.3 m (24 ft)

POWER TRAIN

- Drain, ecology
(transmission, torque converter)

For more complete information on Cat products, dealer services, and industry solutions, visit us on the web at www.cat.com

AEHQ7092 (08-2013)
Replaces AEHQ5574-02

© 2013 Caterpillar Inc.
All rights reserved

Materials and specifications are subject to change without notice. Featured machines in photos may include additional equipment. See your Cat dealer for available options.

CAT, CATERPILLAR, SAFETY.CAT.COM, their respective logos, "Caterpillar Yellow" and the "Power Edge" trade dress, as well as corporate and product identity used herein, are trademarks of Caterpillar and may not be used without permission.

