

# 336E L/LN H

Hydraulic Excavator



## Engine

Engine Model	Cat® C9.3 (ATAAC)
Net Power – ISO 14396 (metric)	237 kW (322 hp)
Net Power – ISO 9249 (metric)	230 kW (313 hp)

## Drive

Maximum Travel Speed	4.9 km/h
Maximum Drawbar Pull	295 kN

## Weights

Minimum Operating Weight	36 200 kg
Maximum Operating Weight	36 800 kg

## Introduction

If you are looking for a large machine to do more work with less fuel, look no further than the new 336E L/LN H, the industry's first hydraulic hybrid excavator. This unique machine uses recovered energy from the swing to load your trucks all-day long using up to 33 percent less fuel\* than our powerful 336D L/LN machine doing the same amount of work.

More important than being first is being best at delivering the most production with the least amount of fuel to reduce your overall costs and make your business more profitable.

Bottom line is the new 336E L/LN H is designed to put more money in your pocket while making you more competitive, and that's good news for your business.

*\*90-degree truck loading in 90% compacted material.*

## Contents

Hydraulics .....	4
Engine .....	6
Operator Station.....	8
Structures & Undercarriage .....	9
Work Tools.....	10
Front Linkage .....	11
Integrated Technologies.....	12
Serviceability.....	13
Safety .....	14
Complete Customer Care.....	15
Sustainability .....	16
Specifications.....	17
Standard Equipment.....	27





# Hydraulics

The more it works, the more you save.

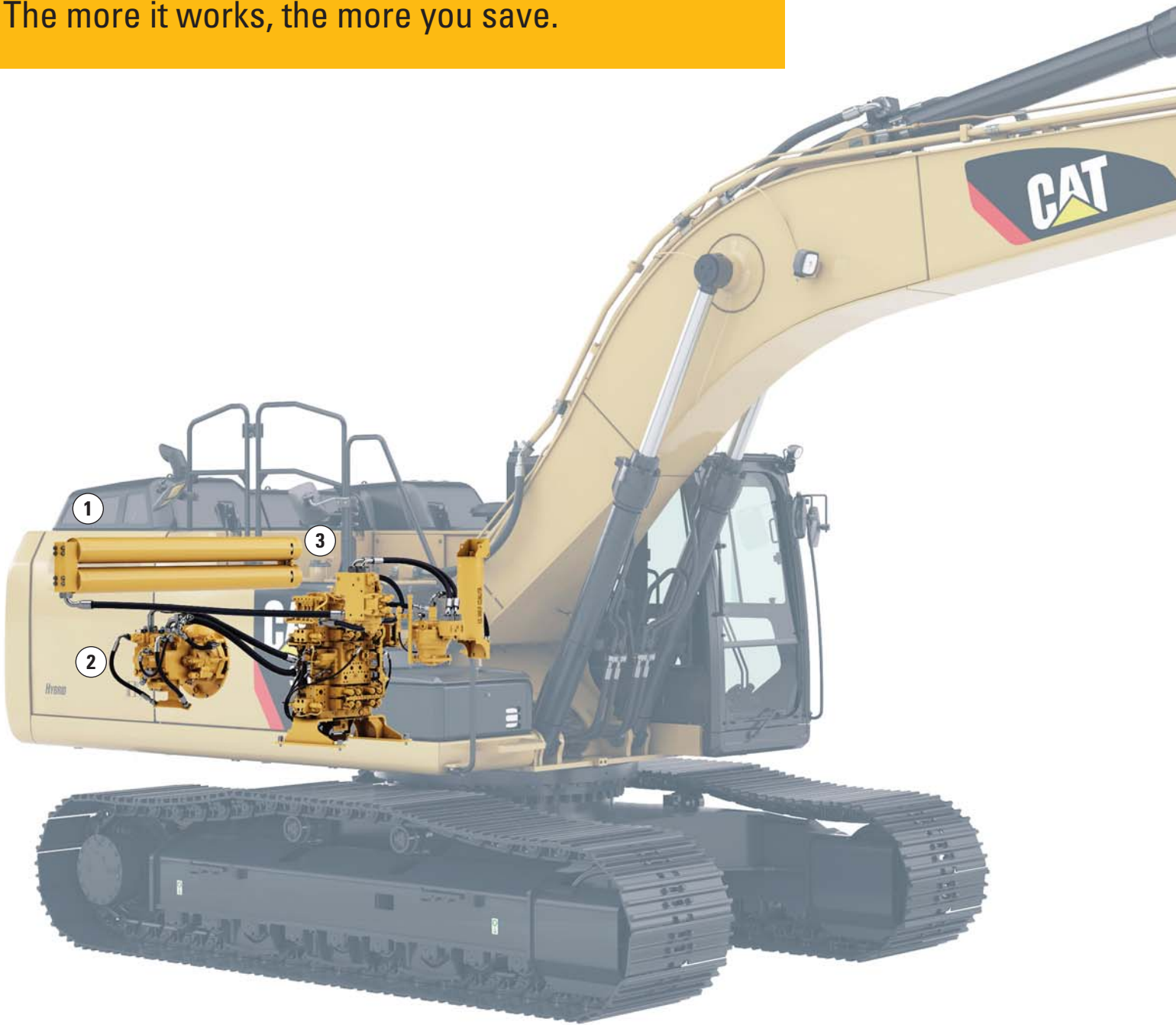

- 1 – Hydraulic Hybrid Swing System
- 2 – Electronic Standardized Programmable (ESP) Pump
- 3 – Adaptive Control System (ACS) Valve

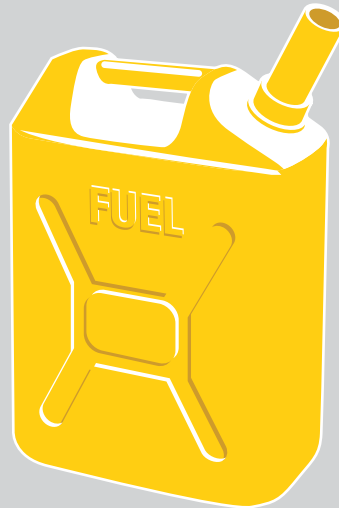

Up to  
**25%**  
less fuel consumption  
than 336E – the fuel  
economy and performance  
leader in its class

Up to  
**33%**  
less fuel consumption  
than 336D

The 336E L/LN H uses three building block technologies to deliver outstanding fuel savings and performance for you:

- The Cat Electronic Standardized Programmable (ESP) pump smoothly transitions between the hydraulic hybrid power sources, engine, and accumulator to conserve fuel.
- The Cat Adaptive Control System (ACS) valve optimizes performance by intelligently managing restrictions and flows to control machine motion, which means your operators will have the power and precision they need and expect.
- The Cat Hydraulic Hybrid Swing System captures the excavator's upper structure swing brake energy in accumulators and then reuses the energy during swing acceleration.

Bottom line is the hydraulic hybrid system is a simple, reliable, and cost-effective solution that will help you significantly reduce your cost per ton.

### **Hydraulic Horsepower, a Cat Advantage**

Hydraulic horsepower is the actual machine power available to do work through implements and work tools. It's much more than just the engine power under the hood – it's a core strength that differentiates Cat machines from other brands. In fact, pump and other system components put more power to the ground, which means moving more material in less time and keeping more money in your pocket at the end of the day.

# Engine

Reduced emissions, economical and reliable performance you can count on.





The Cat C9.3 ACERT™ Stage IIIB engine is built to meet your demanding needs all day long. There is no interruption to your job process because the Cat regeneration system works automatically with no operator intervention required. If your operators are working in heat-restricted areas, they can use a manual override button to move the machine before the regeneration process begins.

### **Power Modes**

The 336E L/LN H features three power modes to help manage fuel consumption: High power, standard power, and economy. Two additional fuel-saving features are on-demand engine power and engine idle shutdown. On-demand engine power keeps speed low during light loading and idling; it automatically adjusts speed up when it senses a heavier load. Engine idle shutdown automatically shuts the engine off when idling for more than a specified amount of time that you set, which can save significant amounts of fuel, reduce your emissions and even reduce your accumulated service hours, which will extend service intervals and improve re-sale value.

### **Biodiesel-Ready Fuel System**

The 336E H runs on ultra-low-sulfur diesel fuel, but you have added flexibility with the C9.3 ACERT engine because it's equipped to run on biodiesel fuel up to B20. Just fill it up and go.



### **Seats**

Not only is the cab as quiet as today's top pickup trucks, but several seat options help give your operators all the comfort they need for a long day of work. Air suspension and heated seats are available, and all include a reclining back, upper and lower seat slide adjustments, and height and tilt angle adjustments.

## **Operator Station**

Your operators will enjoy the incredibly quiet and comfortable cab.

### **Controls**

Your operators can adjust the right and left joysticks for individual preferences, helping the operator become more comfortable, more productive, and more alert. A heavy lift mode increases machine system pressure to improve lift – a nice benefit for your operators in certain situations. It also reduces engine speed and pump flow to improve controllability.

### **Monitor**

Your operators can focus on the job at hand with a high-resolution LCD monitor that is programmable in 42 languages to support today's diverse workforce. It also projects the image from the rearview camera, further increasing job site safety and productivity.

### **Power Supply**

The operator station includes two 12-volt power supply sockets located near the key storage areas for charging electronic devices such as MP3 players and cell phones.

### **Storage**

Your operators can store their gear in storage spaces located in the front, rear, and side consoles. A dedicated space near the auxiliary power supply will hold an MP3 player and cell phone. The drink holder accommodates large mugs with handles, and a shelf behind the seat stores large lunch or toolboxes.

### **Automatic Climate Control**

An automatic climate control system features five air outlets with filtered ventilation to make your operators comfortable in either hot or cold climates.





# Structures & Undercarriage

You can take on a variety of tough tasks with this built-to-last machine.



## Frame

You can expect excellent quality, reliability, and durability with the 336E L/LN H's reinforced lower and upper frames. Both are built to handle a hard day's work over and over again.

## Undercarriage

The 336E H is offered with a Long undercarriage (336E L H) or Long Narrow undercarriage (336E LN H). Heavy-duty track rollers, precision forged carrier rollers, press-fit pin master joints, and enhanced track shoe bolts enhance machine durability and reduce the risk of downtime and your need to replace components. A full-length track guiding guard helps maintain track alignment and protects undercarriage components in rocky applications.

## Counterweight

Whether you are truck loading or trenching, a 4.9 mt\* counterweight gives you plenty of weight and balance for the high-production work this machine is designed to take on. With integrated links, the counterweight can easily be removed for maintenance or shipping.

*\*Two accumulators and a bracket provide additional weight.*

# Work Tools

You can dig, hammer, rip, and cut with confidence.



You can extend the versatility and performance of your machine with the full lineup of Cat work tools. Each tool equips your machine to perform many different tasks found at a variety of job sites.

## **Couplers: Quick Tool Changes**

Imagine the productivity you'll achieve with a quick coupler. Combine a robust coupler with a common work tool inventory that can be shared between same size machines, and you'll get performance and flexibility on every job.

## **Work Tools: Cut, Crush, Pulverize, and Load**

No matter your specialty, Caterpillar provides tools that are perfectly matched to get the most out of your Cat machine – quickly and efficiently.

## **Buckets: Dig, Move, Load**

Cat buckets are designed to fill efficiently so you notice a fast, smooth cycle which means high productivity each time you dig. Wear characteristics of General Duty, Heavy Duty and Severe Duty buckets give you solid performance in a wide variety of material abrasions. Ditch cleaning and other specialty buckets are available when needed.



## Front Linkage

You'll experience a long service life even in the harshest of conditions.

Your uptime and service intervals are increased with high-quality, durable, and reliable booms, sticks, and linkage pins. Each boom and stick is built with internal baffle plates for additional durability, and each undergoes ultrasound inspection to ensure quality and reliability for the tough work you do.

The 336E L/LN H is offered with a 6.5 m heavy-duty reach boom and a 3.2 m heavy-duty stick.

The heavy-duty reach boom covers all the applications this size of machine was designed to take on such as digging dirt, moving rock, placing pipe, and the endless amount of tasks that can be done with Cat hydraulic work tools.

# Integrated Technologies

Make your team's work easier and more efficient.



## Cat Product Link™

You can monitor and improve your fleet management with Cat Product Link. The integrated system reports events, diagnostic codes, hours, fuel consumption, location, and other pieces of detailed machine information to the secured web-based application called Vision Link™. The powerful tools within Vision Link communicate with you and your authorized Cat dealer to help avoid downtime and better maintain your fleet.

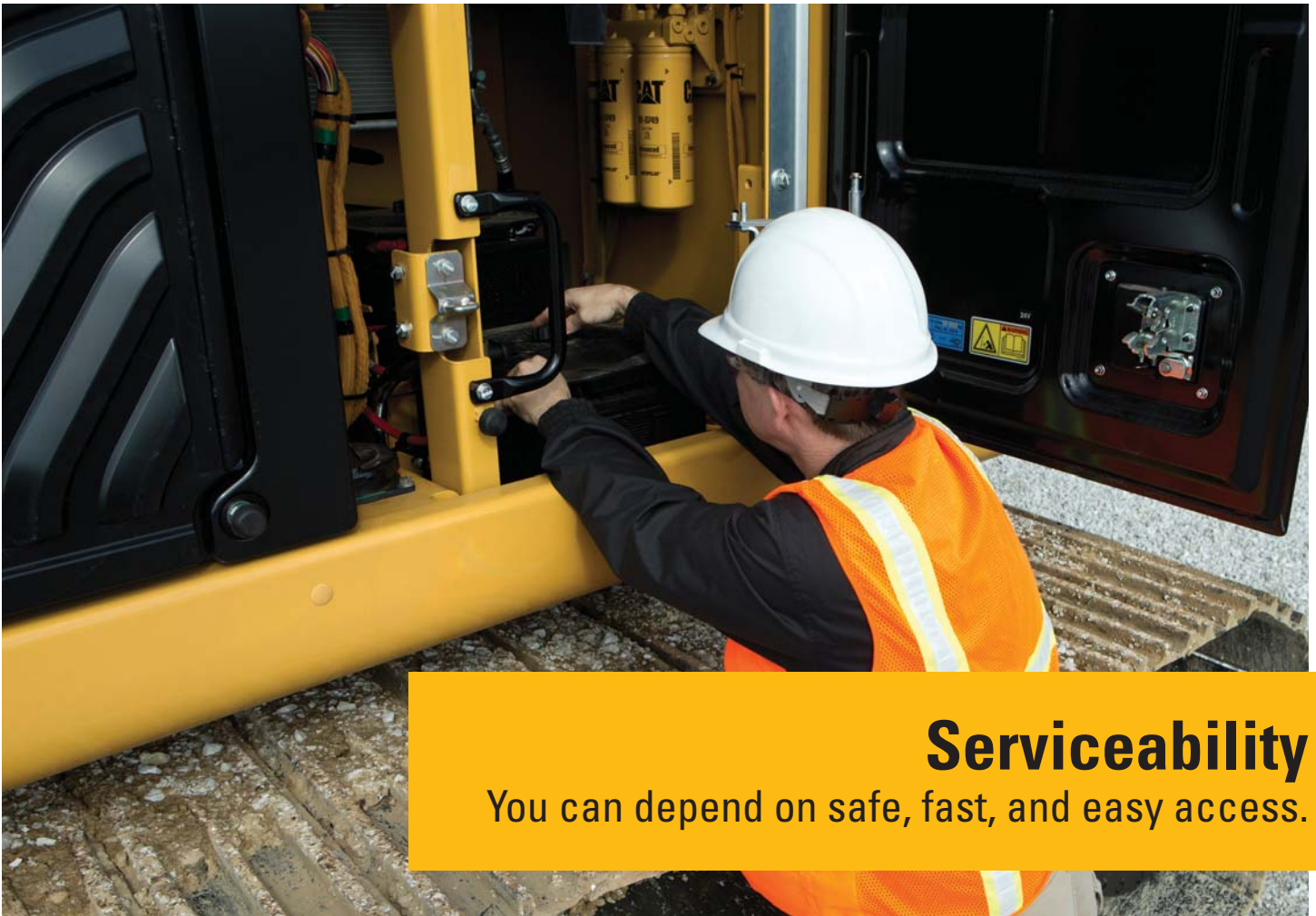

# Serviceability

You can depend on safe, fast, and easy access.



## Ground-Level Compartments

Your service technicians have ground-level access to the radiator, pump, and air cleaner compartments through wide service doors, making it easy for them to reach, check, and replace fluids and filters.

## Other Service Benefits

The water separator with water level sensor has a primary fuel filter element located in the pump compartment near ground level; the electric priming pump is mounted on the primary filter base and is easier to service than traditional hand-priming pumps.

The engine oil dipstick is conveniently located in the front of the engine compartment.

The fuel tank's remote drain cock makes it easy and simple to remove water and sediment during routine maintenance.

Overfilling the fuel tank is significantly reduced with an integrated fuel level indicator.



# Safety

Several built-in features will help protect your people.

## Roll-Over Protective Structure (ROPS) Cab

In the event of a roll-over, your operators will benefit from the enhanced protection of a ROPS-certified cab.

## Anti-Skid Plates

Slipping hazards are reduced with anti-skid plates on the surface of the upper structure and the top of the storage box area.

## Steps, Hand and Guard Rails

Your service technicians can work securely on the machine with extended hand and guard rails to the upper deck and steps on the track frame and storage box.

## Lights

Halogen lights provide plenty of illumination. They can be programmed to stay on for up to 90 seconds after the engine has been turned off to help your operators safely exit the machine.

## Visibility – Windows

The 70/30 split configuration features an upper window equipped with handles on the top and both sides so the operator can slide it to store in the ceiling. The lower window is removable and can be stored on the left wall of the cab shell.

A one-piece fixed front windshield provides operators an unobstructed forward view, and the large skylight provides great overhead visibility.

## Wiper System

The parallel wiper system covers most of the front window without leaving unwiped areas in the line of sight of the operator.

## Rearview Camera

Your operator has a clear view behind the machine through the monitor with the rearview camera. It is housed in the counterweight for increased protection.





## **Complete Customer Care**

Your Cat dealer will support you like no other.

### **Product Support**

You can maximize your machines' uptime with the Cat worldwide dealer network. You can also decrease your repair costs by utilizing Cat remanufactured components while contributing to sustainable development.

### **Machine Selection**

What are your job requirements and machine attachments? What production do you need? Your Cat dealer can provide recommendations to help you make the right machine configuration.

### **Purchase**

You can ensure lower owning and operating costs by utilizing unique Cat dealer services and financing options.

### **Customer Support Agreements**

Cat dealers offer a variety of customer support agreements and work with you to develop a plan to meet your specific needs. These plans can cover the entire machine, including attachments, to help protect your investment.

### **Operation**

You can boost your profits by improving your operators' techniques. Your Cat dealer has videos, literature, and other ideas to help increase productivity. Caterpillar also offers simulators and certified operator training to help maximize the return on your investment.

### **Replacement**

Repair, rebuild, or replace? Your Cat dealer can help evaluate the cost involved so you can make the best choice for your business.

- The 336E L/LN H moves as much material as a standard 336E L/LN yet burns up to 25% less fuel in truck loading applications. This means more efficiency and productivity for you with less resource consumption and fewer CO<sub>2</sub> emissions.
- In terms of CO<sub>2</sub> reduction, a 25% fuel advantage is equivalent to removing 12 passenger cars off the road annually.  
Source: EPA website.
- The 336E L/LN H has the flexibility of running on either ultra-low-sulfur diesel (ULSD) fuel with 15 ppm of sulfur or less or biodiesel fuel up to B20 blended with ULSD.
- An overfill indicator rises when the tank is full to help your service technicians avoid spilling.
- You can ensure fast, easy, and secure changing of engine and hydraulic oil with the Cat QuickEvac™ system.
- A unique engine oil filter eliminates the need for painted metal cans and aluminum top plates. The cartridge-style spin-on housing enables the internal filter to be separated and replaced; the used internal element can be incinerated to help reduce waste.

## Sustainability

Your machine is designed to benefit generations ahead.





# 336E L/LN H Hydraulic Excavator Specifications

## Engine

Engine Model	Cat C9.3 (ATAAC)
Net Power – ISO 9249	230 kW
Net Power – ISO 9249	313 hp (metric)
Net Power – ISO 9249	308 hp (imperial)
Power – ISO 14396	237 kW
Power – ISO 14396	322 hp (metric)
Power – ISO 14396	318 hp (imperial)
Bore	115 mm
Stroke	149 mm
Displacement	9.3 L

## Weights

336E LN H Operating Weight	36 200 kg
336E L H Operating Weight	36 800 kg

## Hydraulic System

Main System – Maximum Flow (Total)	570 L/min
Swing System – Maximum Flow	276 L/min
Maximum Pressure – Equipment	35 000 kPa
Maximum Pressure – Equipment (Heavy Lift)	37 000 kPa
Maximum Pressure – Travel	35 000 kPa
Maximum Pressure – Swing	28 000 kPa
Pilot System – Maximum Flow	28 L/min
Pilot System – Maximum Pressure	4100 kPa
Boom Cylinder – Bore	150 mm
Boom Cylinder – Stroke	1440 mm
Stick Cylinder – Bore	170 mm
Stick Cylinder – Stroke	1738 mm
DB Bucket Cylinder – Bore	150 mm
DB Bucket Cylinder – Stroke	1151 mm

## Drive

Maximum Travel Speed	4.9 km/h
Maximum Drawbar Pull	295 kN
Gradeability	35°/70%

## Swing Mechanism

Swing Speed	9.0 rpm
Swing Torque	109 kN·m

## Service Refill Capacities

Fuel Tank Capacity	620 L
Cooling System	56 L
Engine Oil (with filter)	30.5 L
Swing Drive (each)	19 L
Final Drive (each)	8 L
Hydraulic System (including tank)	380 L
Hydraulic Tank	175 L

## Sound Performance

Operator Noise – ISO 6396	72 dB(A)
---------------------------	----------

# 336E L/LN H Hydraulic Excavator Specifications

## Dimensions

All dimensions are approximate.

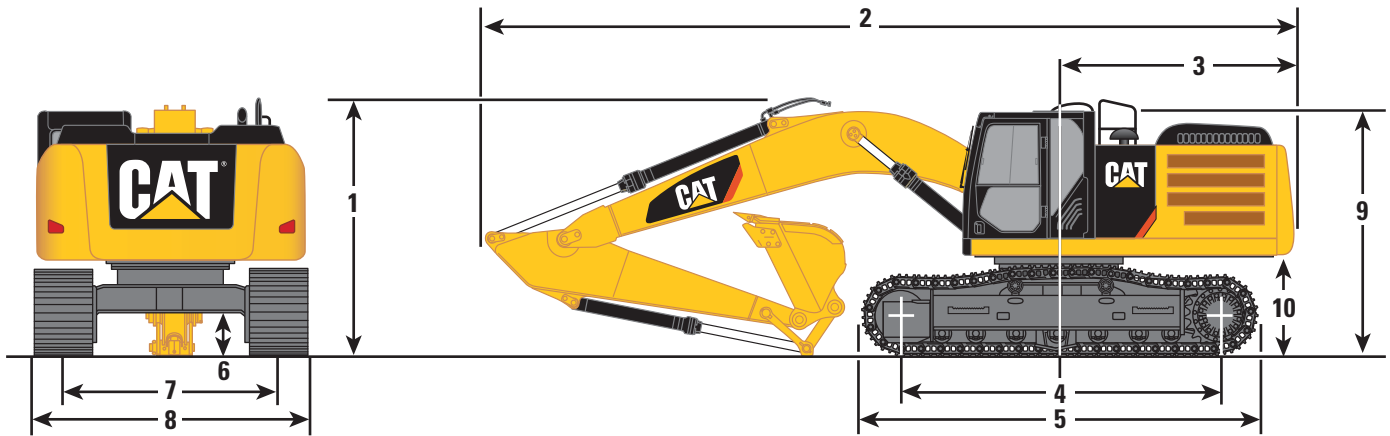

	<b>HD Reach Boom 6.50 m R3.2DB</b>
<b>Stick</b>	<b>R3.2DB</b>
<b>1</b> Shipping Height including Shoe Lug Height	3510 mm
Shipping Height with Top Guard	3510 mm
<b>2</b> Shipping Length	11 160 mm
<b>3</b> Tail Swing Radius	3490 mm
<b>4</b> Length to Center of Rollers	
Long Undercarriage	4040 mm
Long Narrow Undercarriage	4040 mm
<b>5</b> Track Length	
Long Undercarriage	5020 mm
Long Narrow Undercarriage	5020 mm
<b>6</b> Ground Clearance including Shoe Lug Height	510 mm
Ground Clearance without Shoe Lug Height	480 mm
<b>7</b> Track Gauge	
Long Undercarriage	2590 mm
Long Narrow Undercarriage	2390 mm
<b>8</b> Transport Width	
Long Undercarriage (600 mm double grouser track shoes)	3190 mm
Long Narrow Undercarriage (600 mm triple grouser track shoes)	2990 mm
<b>9</b> Cab Height	3150 mm
Cab Height with Top Guard	3360 mm
<b>10</b> Counterweight Clearance without Shoe Lug Height	1220 mm
Bucket Capacity	2.28 m <sup>3</sup>
Bucket Tip Radius	1760 mm

## Working Ranges

All dimensions are approximate.

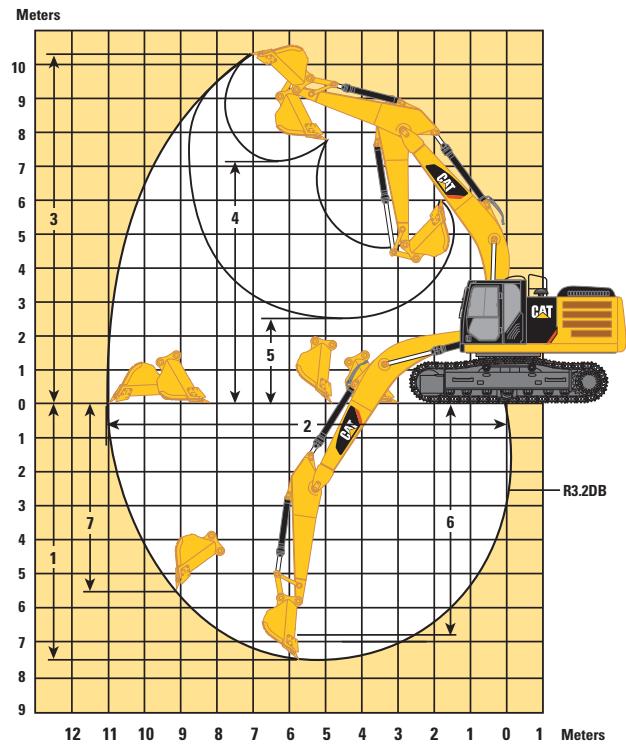

	<b>HD Reach Boom 6.50 m</b>
<b>Stick</b>	<b>R3.2DB</b>
<b>1</b> Maximum Digging Depth	7490 mm
<b>2</b> Maximum Reach at Ground Level	11 020 mm
<b>3</b> Maximum Cutting Height	10 320 mm
<b>4</b> Maximum Loading Height	7110 mm
<b>5</b> Minimum Loading Height	2610 mm
<b>6</b> Maximum Depth Cut for 2440 mm Level Bottom	6820 mm
<b>7</b> Maximum Vertical Wall Digging Depth	5500 mm
Bucket Capacity	2.28 m <sup>3</sup>
Bucket Tip Radius	1760 mm

# 336E L/LN H Hydraulic Excavator Specifications

## Major Component Weights\*

Lower Structure (without counterweight and track)	
Long Undercarriage	8700 kg
Long Narrow Undercarriage	8600 kg
Upper Structure (without front linkage)	10 000 kg
Counterweight 4.9 mt	4900 kg
Boom (includes lines, pins and stick cylinder)	
HD Reach Boom – 6.50 m	4100 kg
Stick (includes lines, pins and bucket cylinder)	
R3.2DB HD	1800 kg
Track Shoe	
Long Undercarriage (600 mm double grouser)	4900 kg
Long Narrow Undercarriage (600 mm triple grouser)	4700 kg
Bucket	
2.28 m <sup>3</sup>	1500 kg

\*Base machine includes 75 kg operator weight, 90% fuel weight and undercarriage.

## Operating Weight and Ground Pressure

	Operating Weight	Ground Pressure
HD Reach Boom and HD R3.2DB Stick		
Long Undercarriage (600 mm double grouser track shoes)	36 800 kg	68.6 kPa
Long Narrow Undercarriage (600 mm triple grouser track shoes)	36 200 kg	68.6 kPa

## Bucket and Stick Forces









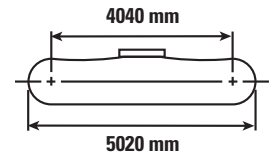
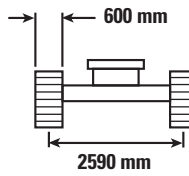
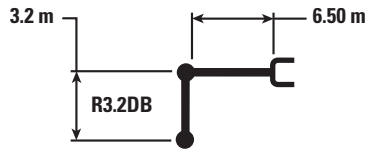

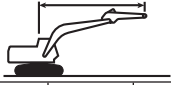



Stick	HD Reach Boom 6.50 m
	R3.2DB
General Duty	
Bucket Digging Force (ISO)	211.8 kN
Stick Digging Force (ISO)	166.7 kN
General Duty Capacity	
Bucket Digging Force (ISO)	209.7 kN
Stick Digging Force (ISO)	165.9 kN
Heavy Duty	
Bucket Digging Force (ISO)	209.9 kN
Stick Digging Force (ISO)	166.1 kN
Heavy Duty – Power	
Bucket Digging Force (ISO)	234.2 kN
Stick Digging Force (ISO)	169.0 kN
Severe Duty	
Bucket Digging Force (ISO)	209.9 kN
Stick Digging Force (ISO)	166.1 kN
Extreme Duty	
Bucket Digging Force (ISO)	209.9 kN
Stick Digging Force (ISO)	166.1 kN

Caterpillar recommends using appropriate work tools to maximize the value customers receive from our products. Use of work tools, including buckets, which are outside of Caterpillar's recommendations or specifications for weight, dimensions, flows, pressures, etc. may result in less-than-optimal performance, including but not limited to reductions in production, stability, reliability, and component durability. Improper use of a work tool resulting in sweeping, prying, twisting and/or catching of heavy loads will reduce the life of the boom and stick.

# 336E L/LN H Hydraulic Excavator Specifications

## 336E L H with HD Reach Boom Lift Capacities – Counterweight: 4.9 mt – Heavy Lift: On



		1.5 m		3.0 m		4.5 m		6.0 m		7.5 m		9.0 m				
																m
7.5 m	kg									*8500	7400			*7200	7050	7.70
6.0 m	kg									*8600	7300			*7000	5800	8.58
4.5 m	kg					*13 050	*13 050	*10 500	9950	*9200	7050	8250	5250	*7050	5150	9.13
3.0 m	kg					*16 500	14 150	*12 150	9350	*10 050	6800	8100	5150	*7300	4800	9.40
1.5 m	kg					*19 000	13 200	*13 600	8850	10 400	6500	7950	5000	7400	4650	9.43
0.0 m	kg					*19 850	12 800	14 250	8500	10 200	6300	7850	4900	7550	4750	9.22
-1.5 m	kg			*14 100	*14 100	*19 450	12 700	14 100	8400	10 100	6200			8150	5050	8.74
-3.0 m	kg			*22 200	*22 200	*18 050	12 800	*13 750	8400	10 150	6250			9350	5800	7.96
-4.5 m	kg			*20 250	*20 250	*15 300	13 150	*11 600	8650					*9800	7400	6.75



ISO 10567









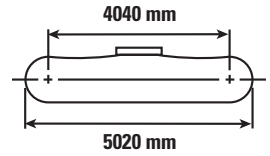
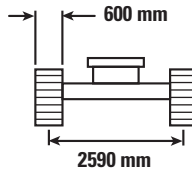
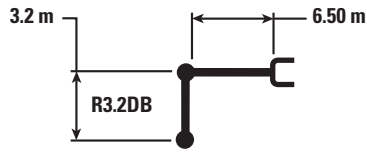

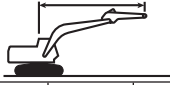





\*Indicates that the load is limited by hydraulic lifting capacity rather than tipping load. The above loads are in compliance with hydraulic excavator lift capacity standard ISO 10567:2007. They do not exceed 87% of hydraulic lifting capacity or 75% of tipping load. Weight of all lifting accessories must be deducted from the above lifting capacities. Lifting capacities are based on the machine standing on a firm, uniform supporting surface. The use of a work tool attachment point to handle/lift objects, could affect the machine lift performance.

Always refer to the appropriate Operation and Maintenance Manual for specific product information.

## 336E LN H with HD Reach Boom Lift Capacities – Counterweight: 4.9 mt – Heavy Lift: On



		1.5 m		3.0 m		4.5 m		6.0 m		7.5 m		9.0 m				
																m
7.5 m	kg									*8500	6750			*7200	6450	7.70
6.0 m	kg									*8600	6700			*7000	5300	8.58
4.5 m	kg					*13 050	*13 050	*10 500	9100	*9200	6450	8150	4800	*7050	4700	9.13
3.0 m	kg					*16 500	12 750	*12 150	8500	*10 050	6200	8000	4700	*7300	4350	9.40
1.5 m	kg					*19 000	11 850	*13 600	8000	10 300	5900	7850	4550	7350	4250	9.43
0.0 m	kg					*19 850	11 450	14 100	7700	10 100	5700	7750	4450	7500	4300	9.22
-1.5 m	kg			*14 100	*14 100	*19 450	11 350	13 950	7550	9950	5600			8050	4600	8.74
-3.0 m	kg			*22 200	*22 200	*18 050	11 450	*13 750	7600	10 000	5650			9250	5250	7.96
-4.5 m	kg			*20 250	*20 250	*15 300	11 800	*11 600	7800					*9800	6700	6.75



ISO 10567



\*Indicates that the load is limited by hydraulic lifting capacity rather than tipping load. The above loads are in compliance with hydraulic excavator lift capacity standard ISO 10567:2007. They do not exceed 87% of hydraulic lifting capacity or 75% of tipping load. Weight of all lifting accessories must be deducted from the above lifting capacities. Lifting capacities are based on the machine standing on a firm, uniform supporting surface. The use of a work tool attachment point to handle/lift objects, could affect the machine lift performance.

Always refer to the appropriate Operation and Maintenance Manual for specific product information.

# 336E L/LN H Hydraulic Excavator Specifications

## Work Tool Offering Guide\*

Boom Option	HD Reach Boom
<b>Stick Option</b>	<b>R3.2DB</b>
Hammer	H140Ds H160Ds
Multi-Processor	MP20 with all jaw options
Mobile Scrap and Demolition Shear	S325B S365C***
Pulverizer	P225 P235**
Compactor (Vibratory Plate)	CVP110
Orange Peel Grapple	
Clamshells	
Rippers	
Universal Quick Coupler	

These work tools are available for the 336E L/LN H.  
Consult your Cat dealer for proper match.

\*Matches are dependent on excavator configurations. Consult your Cat dealer for proper work tool match.

\*\*Pin-on only.

\*\*\*Boom Mount.



## 336E L H Bucket Specifications and Compatibility

	Linkage	Width	Capacity	Weight	Fill	HD Reach Boom
		mm	m <sup>3</sup>	kg	%	R3.2DB
<b>Without Quick Coupler</b>						
General Duty (GD)	DB	1350	1.64	1173	100%	●
	DB	1650	2.11	1352	100%	⊖
	DB	1800	2.35	1453	100%	X
	TB	1500	2.14	1872	100%	
	TB	1650	2.41	2027	100%	
Heavy Duty (HD)	DB	1350	1.64	1481	100%	●
	DB	1500	1.88	1600	100%	⊙
	DB	1650	2.12	1730	100%	⊖
	TB	1650	2.41	2210	100%	
Severe Duty (SD)	DB	1650	2.15	1827	90%	⊖
	TB	1350	1.87	2065	90%	
	TB	1650	2.41	2385	90%	
Maximum load pin-on (payload + bucket)					kg	4830
<b>With Quick Coupler, CW45/CW45s</b>						
General Duty (GD)	DB	1050	1.17	986	100%	●
	DB	1200	1.40	1064	100%	●
	DB	1350	1.64	1143	100%	⊙
	DB	1500	1.87	1245	100%	⊖
	DB	1650	2.11	1324	100%	⊖
Heavy Duty (HD)	DB	1350	1.64	1417	100%	⊙
	DB	1500	1.88	1514	100%	⊖
	DB	1650	2.12	1647	100%	○
	TB	1650	2.41	2117	100%	
Severe Duty (SD)	DB	1050	1.17	1272	90%	●
	DB	1650	2.15	1802	90%	○
	TB	1350	1.87	1974	90%	
	TB	1650	2.41	2295	90%	
Maximum load with coupler (payload + bucket)					kg	4340

The above loads are in compliance with hydraulic excavator standard EN474, they do not exceed 87% of hydraulic lifting capacity or 75% of tipping capacity with front linkage fully extended at ground line with bucket curled.

Capacity based on ISO 7451.

Bucket weight with General Duty tips.

### Maximum Material Density:

- 2100 kg/m<sup>3</sup>
- ⊙ 1800 kg/m<sup>3</sup>
- ⊖ 1500 kg/m<sup>3</sup>
- 1200 kg/m<sup>3</sup>
- X Not Recommended

Caterpillar recommends using appropriate work tools to maximize the value customers receive from our products. Use of work tools, including buckets, which are outside of Caterpillar's recommendations or specifications for weight, dimensions, flows, pressures, etc. may result in less-than-optimal performance, including but not limited to reductions in production, stability, reliability, and component durability. Improper use of a work tool resulting in sweeping, prying, twisting and/or catching of heavy loads will reduce the life of the boom and stick.

# 336E L/LN H Hydraulic Excavator Specifications

## 336E LN H Bucket Specifications and Compatibility

	Linkage	Width	Capacity	Weight	Fill	HD Reach Boom
		mm	m <sup>3</sup>	kg	%	R3.2DB
<b>Without Quick Coupler</b>						
General Duty (GD)	DB	1350	1.64	1173	100%	⊙
	DB	1650	2.11	1352	100%	⊖
	DB	1800	2.35	1453	100%	○
	TB	1500	2.14	1872	100%	
	TB	1650	2.41	2027	100%	
Heavy Duty (HD)	DB	1350	1.64	1481	100%	⊙
	DB	1500	1.88	1600	100%	⊖
	DB	1650	2.12	1730	100%	○
	TB	1650	2.41	2210	100%	
Severe Duty (SD)	DB	1650	2.15	1827	90%	○
	TB	1350	1.87	2065	90%	
	TB	1650	2.41	2385	90%	
Maximum load pin-on (payload + bucket)					kg	4370
<b>With Quick Coupler, CW45/CW45s</b>						
General Duty (GD)	DB	1050	1.17	986	100%	●
	DB	1200	1.40	1064	100%	●
	DB	1350	1.64	1143	100%	⊖
	DB	1500	1.87	1245	100%	○
	DB	1650	2.11	1324	100%	○
Heavy Duty (HD)	DB	1350	1.64	1417	100%	⊖
	DB	1500	1.88	1514	100%	○
	DB	1650	2.12	1647	100%	◇
	TB	1650	2.41	2117	100%	
Severe Duty (SD)	DB	1050	1.17	1272	90%	●
	DB	1650	2.15	1802	90%	◇
	TB	1350	1.87	1974	90%	
	TB	1650	2.41	2295	90%	
Maximum load with coupler (payload + bucket)					kg	3880

The above loads are in compliance with hydraulic excavator standard EN474, they do not exceed 87% of hydraulic lifting capacity or 75% of tipping capacity with front linkage fully extended at ground line with bucket curled.

Capacity based on ISO 7451.

Bucket weight with General Duty tips.

### Maximum Material Density:

- 2100 kg/m<sup>3</sup>
- ⊙ 1800 kg/m<sup>3</sup>
- ⊖ 1500 kg/m<sup>3</sup>
- 1200 kg/m<sup>3</sup>
- ◇ 900 kg/m<sup>3</sup>

Caterpillar recommends using appropriate work tools to maximize the value customers receive from our products. Use of work tools, including buckets, which are outside of Caterpillar's recommendations or specifications for weight, dimensions, flows, pressures, etc. may result in less-than-optimal performance, including but not limited to reductions in production, stability, reliability, and component durability. Improper use of a work tool resulting in sweeping, prying, twisting and/or catching of heavy loads will reduce the life of the boom and stick.

## Standard Equipment

Standard equipment may vary. Consult your Cat dealer for details.

### CAB

- ROPS cab
- Pressurized operator station with positive filtration
- Mirror package
- Sliding upper door window (left-hand cab door)
- Glass-breaking safety hammer
- Coat hook
- Beverage holder
- Literature holder
- Two stereo speakers
- Storage shelf for lunch or toolbox
- Color LCD monitor
- Adjustable armrest
- Height-adjustable joystick consoles
- Neutral lever (lock out) for all controls
- Travel control pedals with removable hand levers
- Capability of installing two additional pedals
- Two power outlets, 10 amp (total)
- Laminated glass front window and tempered other windows
- Cab hatch emergency exit
- Sunscreen
- Parallel wiper
- Air pre-filter
- Travel alarm
- Air seat with backrest and heater
- Seatbelt, retractable (50 cm width)
- Bi-level air conditioner (auto) with defroster (pressurized function)
- Joysticks with three on/off switches and one modulation switch
- 12-volt radio ready
- One piece front windshield (L)
- 70/30 split front windshield (LN)

### COUNTERWEIGHT

- 4.9 mt

### ELECTRICAL

- 80 amp alternator
- Circuit breaker
- Capability to electrically connect a beacon

### ENGINE

- C9.3 diesel engine
- Biodiesel capable
- Meets EU Stage IIIB emission standards
- 2300 m altitude capability
- Electric priming pump
- Automatic engine speed control
- Standard, economy and high power modes
- Two-speed travel
- Side-by-side cooling system
- Radial seal air filter
- Primary filter with water separator and water separator indicator switch
- Fuel differential indicator switch in fuel line
- 2×4 micron main filters and 1×10 micron primary filter in fuel line
- Water level indicator for water separator
- Starting kit, cold weather, -32° C
- Jump start receptacle
- Quick drains, engine and hydraulic oil

### FRONT LINKAGE

- Bucket linkage, DB family with lifting eye
- HD 6.5 m reach boom with left- and right-side light
- Reach 3.2 m stick

### HYDRAULIC SYSTEM

- Automatic swing parking brake
- High performance hydraulic return filter
- Capability of installing additional auxiliary pump and circuit
- Boom lowering control device and stick lowering check valve
- Boom and stick medium pressure lines
- Boom and stick high pressure lines
- Boom and stick QC lines
- Tool control system

### LIGHTS

- Working lights, cab mounted with time delay
- Halogen boom and cab lights with time delay
- Exterior lights integrated into storage box

### UNDERCARRIAGE

- 600 mm triple grouser shoes (LN)
- 600 mm double grouser shoes (L)
- Grease Lubricated Track (GLT2) with resin seal
- Towing eye on base frame
- Guard, heavy-duty bottom
- Swivel guard
- Full length track guiding guard
- Heavy-duty travel motor protection
- Heavy duty rollers

### SECURITY

- Cat one key security system
- Door locks
- Cap locks on fuel and hydraulic tanks
- Lockable external tool/storage box
- Signaling/warning horn
- Secondary engine shutoff switch
- Openable skylight for emergency exit
- Rearview camera

### TECHNOLOGY

- Product Link

For more complete information on Cat products, dealer services, and industry solutions, visit us on the web at [www.cat.com](http://www.cat.com)

© 2013 Caterpillar Inc.  
All rights reserved

Materials and specifications are subject to change without notice. Featured machines in photos may include additional equipment. See your Cat dealer for available options.

CAT, CATERPILLAR, SAFETY.CAT.COM, their respective logos, "Caterpillar Yellow" and the "Power Edge" trade dress, as well as corporate and product identity used herein, are trademarks of Caterpillar and may not be used without permission.

AEHQ6948-01 (03-2013)  
Replaces AEHQ6948  
(Europe)

