

# 430F/430F IT

Backhoe Loaders



## Engine

Engine Model	Cat® C4.4 ACERT™	
Rated Net Power – SAE J1349	80 kW	107 hp
Rated Net Power – ISO 9249	81 kW	109 hp

## Weights

Operating Weight – Nominal	7125 kg	15,708 lb
Operating Weight – Maximum	11 000 kg	24,251 lb

## Backhoe

Dig Depth – Standard	4698 mm	15'5"
Dig Depth – E-Stick Extended	5935 mm	19'6"

## Features

### Industry Leading Cab

*Standard air suspension seat, extra legroom and ergonomic joystick controls make you more comfortable for a more productive work day.*

### Superior Power

*Increased horsepower delivers greater pushing power, increased aggressiveness in hard bank loading and faster roading and hill climbing.*

### Load Sensing Hydraulics

*New electronic pump control provides better pump response for improved hoe and loader productivity, performance and power management.*

### Outstanding Performance

*New front loader arms deliver more reach, dump height and breakout.*

### Cat Durability

*New backhoe swing structures provide more durability in the toughest applications.*

## Contents

Operator Station.....	4
Power Train.....	6
Hydraulics .....	7
Backhoe Performance .....	8
Loader Performance.....	8
Work Tools.....	9
Serviceability.....	10
Customer Support.....	10
Specifications.....	11
Standard Equipment.....	22
Optional Equipment.....	23





**Experience the difference of a Cat Backhoe Loader. Spacious operator station features ergonomic joystick controls, ample legroom and an air suspension seat to keep you comfortable all day long. Built for greater reach, dump height, breakout force and pushing power, the Cat 430F/430F IT helps you get more done to improve your bottom line.**

# Operator Station

Spacious working environment for all day comfort.



## Joystick Controls

Ergonomic excavator-style joystick controls provide precise control with low effort. Thumb rollers provide convenient, fingertip control of auxiliary functions, eliminating floor mounted foot pedals.



### **Superior Comfort**

The ergonomic, automotive style operator station helps you work comfortably and productively all day long. Select the configuration that meets your needs – Canopy, Deluxe Cab or Deluxe Cab with air conditioning. Features include:

- Adjustable air suspension seat (standard)
- Excellent visibility over the hood
- Easy-to-read gauge cluster
- Ample legroom
- Automatic Engine Speed Control to conserve fuel
- Storage compartments for tools and belongings

### **Ride Control**

The optional Ride Control System smoothes the ride in all conditions, including load and carry, highway roading or simply moving around the job site. This results in increased operator comfort and improved material retention and facilitates a reduction in operator fatigue.

### **Pattern Selector**

The pattern selector switch, located in the cab, lets you change from an excavator to a backhoe control pattern simply by pressing a button. This lets you use the pattern you are most comfortable with so you can be more productive.



# Power Train

Built for performance, power and fuel efficiency.



## Cat Engine

The Cat C4.4 ACERT engine provides cleaner, quieter operation while delivering superior performance and durability. The engine meets U.S. EPA Tier 4 Interim and EU Stage IIIB emission requirements. The engine also features:

- Passive regeneration system requiring no operator interaction
- Long life diesel particulate filter
- Improved fuel efficiency
- Increased horsepower delivers greater pushing power, increased aggressiveness in hard bank loading and faster roading

## Transmission

The standard power shuttle transmission provides four speeds forward and reverse. Hydraulically shifted clutches allow on-the-go direction and travel speed shifts. The optional auto-shift transmission matches gear with grade and load conditions.

- Hydraulic proportional control valves deliver smooth speed and directional shifts.
- Standard Four Wheel Drive improves mobility and loader performance in poor underfoot conditions and can be activated on-the-go.
- Maximum roading speed of 40 km/h (25 mph) improves travel time between job sites.

## Brake Mode Selector

Brake mode selector switch is standard on the 430F and has three positions: two wheel drive, two wheel drive with all wheel braking and four wheel drive. Two wheel drive with all wheel braking provides better tire life while roading and engages the front axle when brakes are applied for improved braking performance.



## Hydraulics

Load-sensing system matches power to demand.

### Powerful Hydraulic System

The load-sensing, closed center hydraulic system matches pressure and flow to the job demands. Whether you're in full trenching mode or digging around delicate services, you are in control. In applications such as production trenching where speed is important, the system will provide the flow needed to get the job done quickly and efficiently. New electronic pump torque limiter delivers improved power management and hydraulic performance. The load-sensing hydraulic system also delivers:

- Better fuel efficiency
- Quieter operation
- Reduced wear on components
- Cooler hydraulic temperatures
- Full dig and lift forces at any engine speed



# Backhoe Performance

Superior digging forces.

## Boom

The excavator-style boom is built for optimum performance and durability. The curved design provides added clearance when digging over obstacles or loading trucks. The narrow boom enhances the viewing area to the bucket and the trench throughout the operating range. More robust swing casting and double clevis design improves durability and reliability.

## Stick

Serrated edges on the stick provide improved material clamping for clearing and demolition applications. The optional extendible stick (E-stick) increases reach and dig depth by approximately 1.2 m (4 ft).

## Thumbs

Thumb mounting provisions are standard on every Cat Backhoe Loader for added machine versatility. Cat hydraulic thumbs are available for increased versatility. Mechanical thumbs are also available through your Cat dealer.

# Loader Performance

## Powerful new front loader.

New front loader arms deliver more reach, dump height and breakout. Choose the loader linkage that suits your application:

- **Single Tilt** loader linkage (standard) features strong lift and breakout forces for solid performance in backfilling and truck loading applications with pin-on buckets.
- **Integrated Toolcarrier (IT)** loader linkage (optional) provides high breakout forces with parallel lift for efficient loading and material handling. The versatile integrated toolcarrier comes with a standard hydraulic quick coupler and can use a wide range of Cat Work Tools for a variety of applications. The single lever IT loader control provides fine modulation of hydraulic work tools. A thumb roller operates auxiliary hydraulic functions on work tools such as multi purpose buckets, brooms and other attachments.





# Work Tools

Do more jobs with one machine.

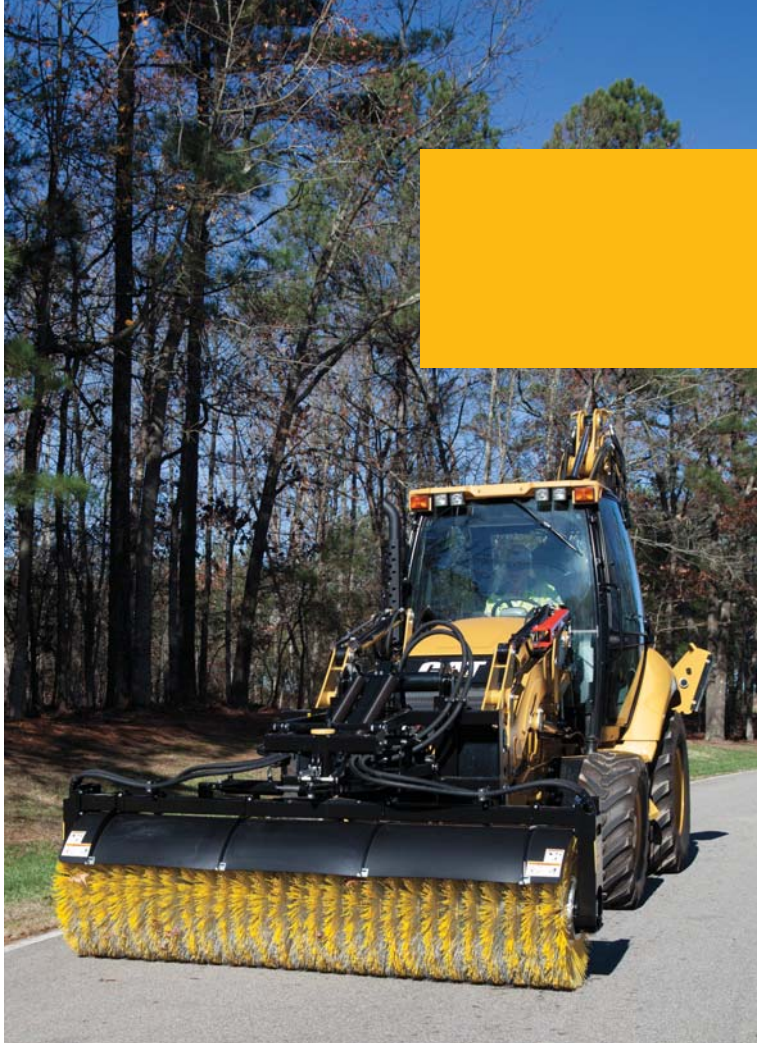

## Backhoe Work Tools

Increase the versatility of your machine with the large selection of backhoe attachments:

- Buckets – Standard Duty, Heavy Duty, Heavy Duty Rock, Soil Excavation, Coral and Ditch Cleaning
- Cold Planers
- Hammers
- Augers
- Rippers
- Thumbs (mechanical and hydraulic)
- Vibratory Plate Compactors
- Quick Couplers



## Loader Work Tools

A wide range of loader attachments is available including:

- Buckets – General Purpose, Multi Purpose, Side Dump and Light Material
- Angle Blades
- Brooms
- Rakes
- Forks
- Material Handling Arms
- Snow Plows

## IT Loader Quick Coupler

The quick coupler allows fast and easy connection to work tools. Mechanical work tools can be changed in less than 30 seconds from the comfort of the operator station.



## Backhoe Quick Coupler

Manual or hydraulic backhoe couplers make rear tool exchange quick and easy. New Cat dual lock coupler has a self-adjusting wedge design to ensure a tight fit. It also features a safety lock that automatically engages.

# Serviceability

Easy maintenance helps keep your machine working.



## Minimize Your Downtime

Convenient service features makes maintenance easy, reducing your downtime:

- Hinged cooling pack provides easy access
- Tilt up hood provides easy, convenient access to all engine check points
- Engine side panels remove easily without the use of tools
- Cat Product Link™ system (optional) provides remote reporting of machine location and operating system parameters

# Customer Support

Unmatched support makes the difference.

## Renowned Dealer Support

From helping you choose the right machine to knowledgeable ongoing support, Cat dealers provide the best in sales and service.

- Preventive maintenance programs and guaranteed maintenance contracts
- Best-in-class parts availability
- Operator training to help boost your profits
- Genuine Cat Remanufactured parts

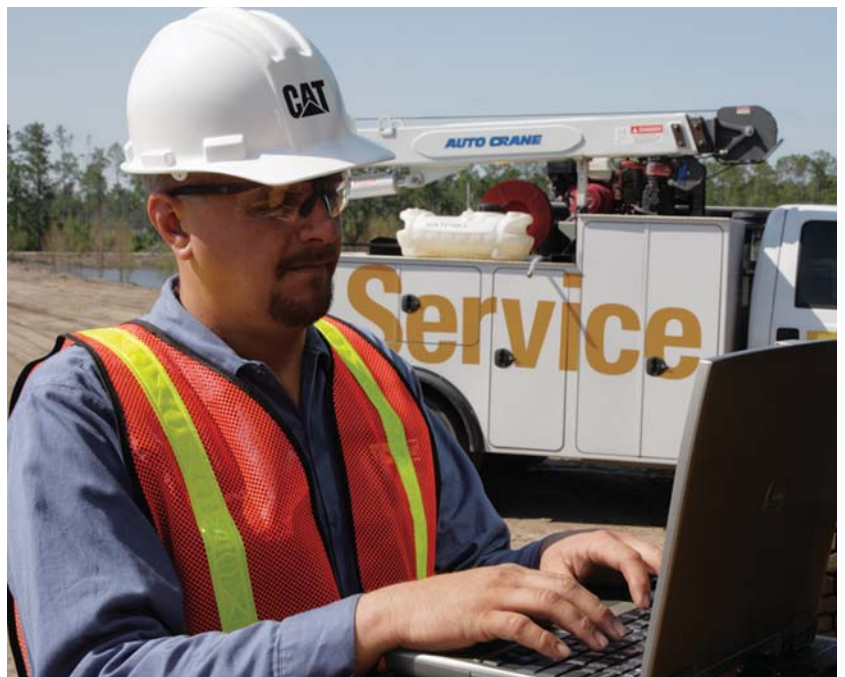

## Engine

Engine Model	Cat C4.4 ACERT	
Gross Power		
SAE J1995	87 kW	117 hp
ISO 14396	86 kW	115 hp
Rated Net Power @ 2,200 rpm		
SAE J1349	80 kW	107 hp
ISO 9249/EEC 80/1269	81 kW	109 hp
Net Peak Power @ 1,800 rpm		
SAE J1349	82 kW	110 hp
ISO 9249	83 kW	111 hp
EEC 80/1269	83 kW	111 hp
Bore	105 mm	4.13 in
Stroke	127 mm	5 in
Displacement	4.4 L	268 in <sup>3</sup>
Net Torque Rise @ 1,400 rpm – SAE J1349	40%	
Net Peak Torque @ 1,400 rpm	489 N·m	361 lb-ft

- Engine meets U.S. EPA Tier 4 Interim/EU Stage IIIB emission standards.

## Transmission

Power Shuttle Transmission – Standard		
Forward – 1st	6 km/h	3.7 mph
Forward – 2nd	9.6 km/h	5.9 mph
Forward – 3rd	20 km/h	12 mph
Forward – 4th	40 km/h	25 mph
Reverse – 1st	6 km/h	3.7 mph
Reverse – 2nd	9.6 km/h	5.9 mph
Reverse – 3rd	20 km/h	12 mph
Reverse – 4th	40 km/h	25 mph
AutoShift Transmission – Optional		
Forward – 1st	5.9 km/h	3.7 mph
Forward – 2nd	9.5 km/h	5.9 mph
Forward – 3rd	20 km/h	12 mph
Forward – 4th	27 km/h	17 mph
Forward – 5th	42 km/h	26 mph
Reverse – 1st	5.9 km/h	3.7 mph
Reverse – 2nd	13 km/h	7.8 mph
Reverse – 3rd	27 km/h	17 mph

## Weights\*

Operating Weight – Nominal	7125 kg	15,708 lb
Operating Weight – Maximum	11 000 kg	24,251 lb
Cab, ROPS/FOPS	184 kg	406 lb
AutoShift Transmission	216 kg	476 lb
Ride Control	14 kg	31 lb
Air Conditioning	26 kg	57 lb
Four Wheel Drive	N/A	N/A
MP Bucket (0.96 m <sup>3</sup> /1.25 yd <sup>3</sup> ) (no forks or teeth)	745 kg	1,642 lb
Loader, IT with Quick Coupler	197 kg	434 lb
Extendible Stick	321 kg	708 lb
Counterweights (Option 1)	115 kg	255 lb
Counterweights (Option 2)	240 kg	530 lb
Counterweights (Option 3)	460 kg	1,015 lb

- \* Specifications shown are for machine equipped with 1.0 m<sup>3</sup> (1.31 yd<sup>3</sup>) general purpose loader bucket, 610 mm (24 in) heavy duty backhoe bucket, 80 kg (176 lb) operator and full fuel tank.

## Steering

Type	Front Wheel	
Power Steering	Hydrostatic	
Bore	65 mm	2.6 in
Stroke	120 mm	4.7 in
Rod Diameter	36 mm	1.4 in
Axle Oscillation	11°	
Turning Circle – 4WD (inner wheel not braked)		
Outside, Front Wheels	8.18 m	26'10"
Outside, Widest Loading Bucket	10.97 m	36'0"

## Axle Ratings

Front Axle, 4WD		
Static	22 964 kg	50,582 lb
Dynamic	9186 kg	20,233 lb
Rear Axle		
Static	22 964 kg	50,582 lb
Dynamic	9186 kg	20,233 lb
Axle Oscillation	10 Degrees	

- 4WD axles are pendulum mounted and permanently sealed and lubricated, requiring no daily maintenance. Also features double-acting steering cylinder with 52° steering angle for increased maneuverability.

# 430F/430F IT Specifications

## Hydraulic System

Type	Closed Center	
Pump Type	Variable Flow, Axial Piston	
Pump Capacity @ 2,200 rpm	163 L/min	43 gal/min
System Pressure – Backhoe	25 000 kPa	3,600 psi
System Pressure – Loader	25 000 kPa	3,600 psi

## Service Refill Capacities

Cooling System with Air Conditioning	22 L	5.8 gal
Fuel Tank	170 L	45 gal
Engine Oil with Filter	7.6 L	2.0 gal
Transmission – Power Shuttle		
4WD	18.5 L	4.9 gal
Transmission – AutoShift		
4WD	19.0 L	5.0 gal
Rear Axle	16.5 L	4.4 gal
Planetaries	1.7 L	0.4 gal
Front Axle (4WD)	11.0 L	2.9 gal
Planetaries	0.7 L	0.2 gal
Hydraulic System	95.0 L	25.1 gal
Hydraulic Tank	42.0 L	11.1 gal

- Requires ultra-low sulfur fuel  $\leq$  15 ppm fuel sulfur.

## Tires

Choices listed as combination of front/rear tires:

- 12.5/80-18 (12 ply) 1-3/19.5L-24 (12 ply) ATU
- 12.5/80-18 NHS (12 ply) 1-3/21L-24 (16 ply) R4 ATU
- 340/80R 18/19.5L-24 (12 ply) R4 ATU
- 340/80R 18/500/70R 24 RT

## Operating Specifications – Backhoe

Turning Circle: Outside, Front Wheels	8.18 m	26'10"
Turning Circle: Outside, Widest	10.97 m	36'0"
Loading Bucket		

- ISO 5010.
- 4WD (inner wheel not braked).

## Engine Features

- Regeneration is passive and does not require any input from the operator or disrupt work.
- Three-ring pistons made of lightweight, silicon/aluminum alloy for strength and maximum thermal conductivity.
- Forged chrome/molybdenum-steel crankshaft with crankshaft with either induction hardened or nitrocarburized journals.
- Front and rear crankshaft oil seals are “lip” type Viton and PTFE designs featuring an integral dust lip.
- Heat resistant, silicone-chrome steel intake and STELLITE-faced exhaust valves provide long life.
- Cylinder block is high strength, cast iron alloy of deep skirt, monobloc design for increased strength and long life.
- Cylinder head is high strength, cast iron alloy construction with extra duty wall and deck thickness. Intake and exhaust ports are precision cast to promote optimum gas flow.
- Direct injection fuel system provides accurate fuel delivery; remote mounted electric lift pump improves serviceability.
- Dry-type axial seal air cleaner with integral precleaner, automatic dust ejection system, and filter condition indicator.
- Direct electric, 12-volt starting and charging system with 880 CCA Group 31 maintenance free battery.
- Standard glow plug starting aid system for efficient cold weather starting.
- High contact ratio/gear train, peripheral fixed isolation top cover and open deck block design reduce bare engine noise.
- Higher low end torque for better engine/machine performance.
- Engine is equipped with electric fuel priming pump.

## Brakes

Features:

- Brakes meet the following standards: SAE J1473 and ISO 3450 requirements.
- Self-adjusting, completely enclosed and sealed.
- Foot operated brake pedals can be interlocked for roading.
- Parking/secondary brakes are independent of the service brake system. Parking brake is mechanically applied through an adjustable hand lever located on the right console.

## Machine Dimensions

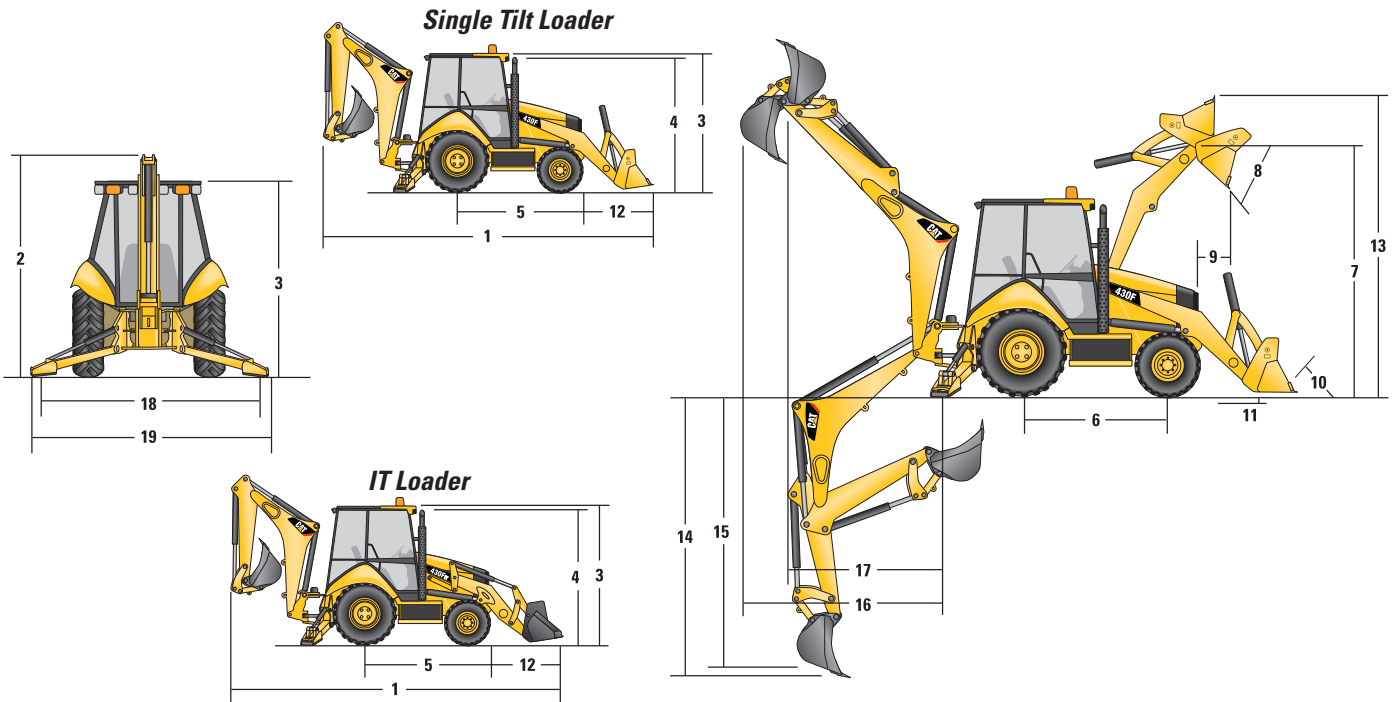

Single Tilt Loader

	General Purpose (0.96 m <sup>3</sup> /1.25 yd <sup>3</sup> )		General Purpose (1.1 m <sup>3</sup> /1.4 yd <sup>3</sup> )		General Purpose (1.15 m <sup>3</sup> /1.5 yd <sup>3</sup> )		Multi Purpose (1.0 m <sup>3</sup> /1.3 yd <sup>3</sup> )		Multi Purpose (1.1 m <sup>3</sup> /1.4 yd <sup>3</sup> )	
<b>1</b> Overall Transport Length	7282 mm	23'11"	7302 mm	23'11"	7302 mm	23'11"	7200 mm	23'7"	7200 mm	23'7"
Overall Length (loader on ground)	7310 mm	24'0"	7348 mm	24'1"	7348 mm	24'1"	7274 mm	23'10"	7274 mm	23'10"
<b>2</b> Overall Transport Height – Standard Stick	3577 mm	11'9"	3577 mm	11'9"	3577 mm	11'9"	3577 mm	11'9"	3577 mm	11'9"
Overall Transport Height – Extendible Stick	3631 mm	11'11"	3631 mm	11'11"	3631 mm	11'11"	3631 mm	11'11"	3631 mm	11'11"
Overall Width	2322 mm	7'7"	2322 mm	7'7"	2322 mm	7'7"	2322 mm	7'7"	2322 mm	7'7"
<b>3</b> Height to Top of Cab/Canopy	2819 mm	9'3"	2819 mm	9'3"	2819 mm	9'3"	2819 mm	9'3"	2819 mm	9'3"
<b>4</b> Height to Top of Exhaust Stack	2744 mm	9'0"	2744 mm	9'0"	2744 mm	9'0"	2744 mm	9'0"	2744 mm	9'0"
Height to Loader Hinge Pin (transport)	381 mm	1'3"	428 mm	1'5"	428 mm	1'5"	432 mm	1'5"	432 mm	1'5"
Ground Clearance (minimum)	320 mm	1'1"	320 mm	1'1"	320 mm	1'1"	320 mm	1'1"	320 mm	1'1"
<b>5</b> Rear Axle Centerline to Front Grill	2705 mm	8'10"	2705 mm	8'10"	2705 mm	8'10"	2705 mm	8'10"	2705 mm	8'10"
Front Wheel Tread Gauge	1895 mm	6'3"	1895 mm	6'3"	1895 mm	6'3"	1895 mm	6'3"	1895 mm	6'3"
Rear Wheel Tread Gauge	1714 mm	5'7"	1714 mm	5'7"	1714 mm	5'7"	1714 mm	5'7"	1714 mm	5'7"
<b>6</b> Wheelbase 2WD/AWD	2200 mm	7'3"	2200 mm	7'3"	2200 mm	7'3"	2200 mm	7'3"	2200 mm	7'3"

Dimensions and performance specifications shown are for machines equipped with 12.5/80-18 SGL front tires, 19.5L-24 IT525 rear tires, ROPS canopy, standard stick with 610 mm (24 in) standard duty bucket, 1.0 m<sup>3</sup> (1.31 yd<sup>3</sup>) loader bucket and standard equipment unless otherwise specified.

# 430F/430F IT Specifications

## Machine Dimensions

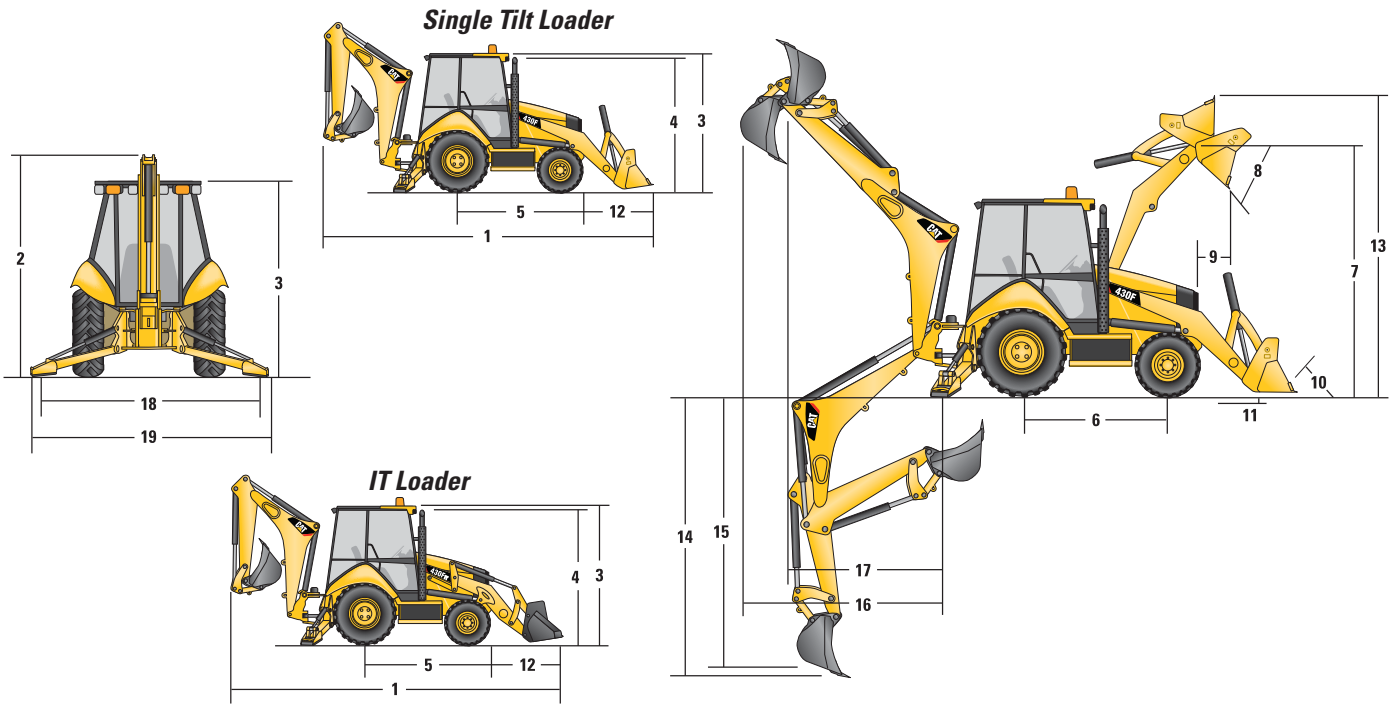

### IT Loader with Quick Coupler

	General Purpose (1.0 m <sup>3</sup> /1.3 yd <sup>3</sup> )		General Purpose (1.15 m <sup>3</sup> /1.5 yd <sup>3</sup> )		Multi Purpose (1.1 m <sup>3</sup> /1.4 yd <sup>3</sup> )	
	mm	ft/in	mm	ft/in	mm	ft/in
<b>1</b> Overall Transport Length	7385	24'3"	7428	24'4"	7338	24'1"
Overall Length (loader on ground)	7391	24'3"	7420	24'4"	7352	24'1"
<b>2</b> Overall Transport Height – Standard Stick	3577	11'9"	3577	11'9"	3577	11'9"
Overall Transport Height – Extendible Stick	3631	11'11"	3631	11'11"	3631	11'11"
Overall Width	2322	7'7"	2322	7'7"	2322	7'7"
<b>3</b> Height to Top of Cab/Canopy	2819	9'3"	2819	9'3"	2819	9'3"
<b>4</b> Height to Top of Exhaust Stack	2744	9'0"	2744	9'0"	2744	9'0"
Height to Loader Hinge Pin (transport)	396	1'4"	391	1'3"	386	1'3"
Ground Clearance (minimum)	320	1'1"	320	1'1"	320	1'1"
<b>5</b> Rear Axle Centerline to Front Grill	2705	8'10"	2705	8'10"	2705	8'10"
Front Wheel Tread Gauge	1895	6'3"	1895	6'3"	1895	6'3"
Rear Wheel Tread Gauge	1714	5'7"	1714	5'7"	1714	5'7"
<b>6</b> Wheelbase 2WD/AWD	2200	7'3"	2200	7'3"	2200	7'3"

Dimensions and performance specifications shown are for machines equipped with 12.5/80-18 SGL front tires, 19.5L-24 IT525 rear tires, ROPS canopy, standard stick with 610 mm (24 in) standard duty bucket, 1.0 m<sup>3</sup> (1.31 yd<sup>3</sup>) loader bucket and standard equipment unless otherwise specified.

## Loader Bucket Dimensions and Performance

	Single Tilt Loader									
	General Purpose (0.96 m <sup>3</sup> /1.25 yd <sup>3</sup> )		General Purpose (1.1 m <sup>3</sup> /1.4 yd <sup>3</sup> )		General Purpose (1.15 m <sup>3</sup> /1.5 yd <sup>3</sup> )		Multi Purpose (1.0 m <sup>3</sup> /1.3 yd <sup>3</sup> )		Multi Purpose (1.1 m <sup>3</sup> /1.4 yd <sup>3</sup> )	
Capacity (SAE rated)	0.96 m <sup>3</sup>	1.25 yd <sup>3</sup>	1.1 m <sup>3</sup>	1.4 yd <sup>3</sup>	1.15 m <sup>3</sup>	1.5 yd <sup>3</sup>	1.0 m <sup>3</sup>	1.3 yd <sup>3</sup>	1.1 m <sup>3</sup>	1.4 yd <sup>3</sup>
Overall Bucket Width	2262 mm	89"	2262 mm	89"	2406 mm	95"	2279 mm	90"	2425 mm	95"
Lift Capacity at Maximum Height	3282 kg	7,237 lb	3216 kg	7,090 lb	3196 kg	7,046 lb	3097 kg	6,828 lb	3068 kg	6,764 lb
Lift Breakout Force	49 809 N	11,197 lb	49 275 N	11,077 lb	49 099 N	11,037 lb	49 019 N	11,020 lb	48 771 N	10,964 lb
Tilt Breakout Force	50 190 N	11,283 lb	51 236 N	11,518 lb	51 128 N	11,494 lb	57 555 N	12,938 lb	57 408 N	12,905 lb
<b>7</b> Maximum Hinge Pin Height	3474 mm	11'5"	3474 mm	11'5"	3474 mm	11'5"	3474 mm	11'5"	3474 mm	11'5"
<b>8</b> Dump Angle at Full Height	44°		44°		44°		44°		44°	
Dump Height at Maximum Angle	2746 mm	9'0"	2723 mm	8'11"	2723 mm	8'11"	2798 mm	9'2"	2798 mm	9'2"
<b>9</b> Dump Reach at Maximum Angle	808 mm	2'8"	773 mm	2'6"	773 mm	2'6"	716 mm	2'4"	716 mm	2'4"
<b>10</b> Maximum Bucket Rollback at Ground Level	37°		38°		38°		38°		38°	
<b>11</b> Digging Depth	83 mm	3"	123 mm	5"	123 mm	5"	110 mm	4"	110 mm	4"
Maximum Grading Angle	112°		113°		113°		116°		116°	
Width of Dozer Cutting Edge	N/A		N/A		N/A		2262 mm	7'5"	2406 mm	7'11"
<b>12</b> Grill to Bucket Cutting Edge, Carry Position	1487 mm	4'11"	1525 mm	5'0"	1525 mm	5'0"	1451 mm	4'9"	1451 mm	4'9"
<b>13</b> Maximum Operating Height	4355 mm	14'3"	4395 mm	14'5"	4395 mm	14'5"	4404 mm	14'5"	4404 mm	14'5"
Jaw Opening Maximum	N/A		N/A		N/A		790 mm	2'7"	790 mm	2'7"
Bucket Jaw Clamping Force	N/A		N/A		N/A		55 700 N	12,521 lb	55 700 N	12,521 lb
Weight (does not include teeth or forks)	451 kg	994 lb	473 kg	1,043 lb	493 kg	1,087 lb	745 kg	1,642 lb	774 kg	1,706 lb

	IT Loader with Quick Coupler					
	General Purpose (1.0 m <sup>3</sup> /1.3 yd <sup>3</sup> )		General Purpose (1.15 m <sup>3</sup> /1.5 yd <sup>3</sup> )		Multi Purpose (1.1 m <sup>3</sup> /1.4 yd <sup>3</sup> )	
Capacity (SAE rated)	1.0 m <sup>3</sup>	1.3 yd <sup>3</sup>	1.15 m <sup>3</sup>	1.5 yd <sup>3</sup>	1.1 m <sup>3</sup>	1.4 yd <sup>3</sup>
Overall Bucket Width	2406 mm	95"	2406 mm	95"	2425 mm	95"
Lift Capacity at Maximum Height	3707 kg	8,173 lb	3682 kg	8,117 lb	3419 kg	7,537 lb
Lift Breakout Force	51 492 N	11,575 lb	50 778 N	11,415 lb	49 413 N	11,108 lb
Tilt Breakout Force	48 927 N	10,999 lb	46 134 N	10,371 lb	50 214 N	11,288 lb
<b>7</b> Maximum Hinge Pin Height	3490 mm	11'5"	3490 mm	11'5"	3490 mm	11'5"
<b>8</b> Dump Angle at Full Height	44°		44°		44°	
Dump Height at Maximum Angle	2710 mm	8'11"	2680 mm	8'10"	2745 mm	9'0"
<b>9</b> Dump Reach at Maximum Angle	836 mm	2'9"	868 mm	2'10"	814 mm	2'8"
<b>10</b> Maximum Bucket Rollback at Ground Level	40°		40°		40°	
<b>11</b> Digging Depth	105 mm	4"	105 mm	4"	95 mm	4"
Maximum Grading Angle	111°		110°		112°	
Width of Dozer Cutting Edge	N/A		N/A		2406 mm	7'11"
<b>12</b> Grill to Bucket Cutting Edge, Carry Position	1568 mm	5'2"	1597 mm	5'3"	1529 mm	5'0"
<b>13</b> Maximum Operating Height	4407 mm	14'6"	4477 mm	14'8"	4480 mm	14'8"
Jaw Opening Maximum	N/A		N/A		790 mm	2'7"
Bucket Jaw Clamping Force	N/A		N/A		55 700 N	12,521 lb
Weight (does not include teeth or forks)	457 kg	1,008 lb	481 kg	1,060 lb	753 kg	1,660 lb

Dimensions and performance specifications shown are for machines equipped with 12.5/80-18 SGL front tires, 19.5L-24 IT525 rear tires, ROPS canopy, standard stick with 610 mm (24 in) standard duty bucket, 1.0 m<sup>3</sup> (1.31 yd<sup>3</sup>) loader bucket and standard equipment unless otherwise specified.

# 430F/430F IT Specifications

## Backhoe Dimensions and Performance

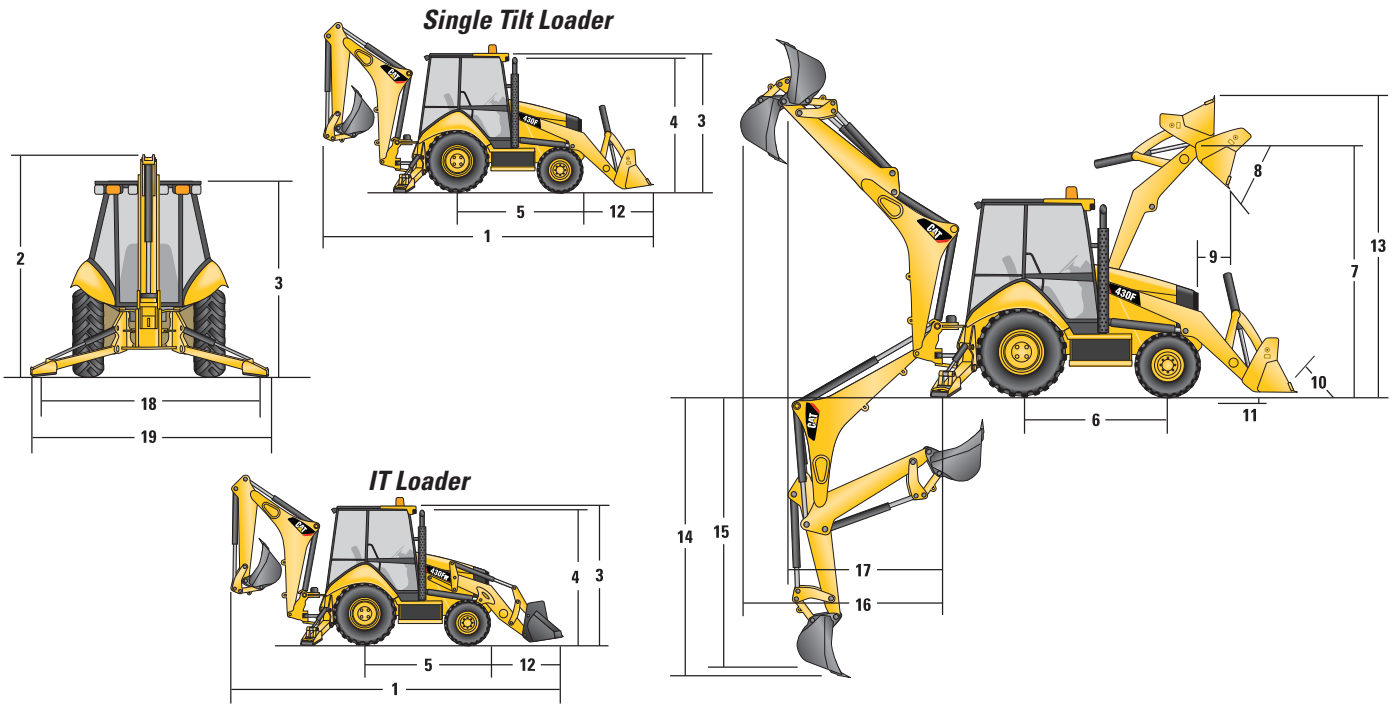

	Standard Stick		E-Stick Retracted		E-Stick Extended	
<b>14</b> Digging Depth, SAE (maximum)	4698 mm	15'5"	4795 mm	15'9"	5935 mm	19'6"
<b>15</b> Digging Depth, 610 mm (2 ft) Flat Bottom	4660 mm	15'4"	4766 mm	15'8"	5906 mm	19'5"
Reach from Rear Axle Centerline at Ground Line	7133 mm	23'6"	7227 mm	23'10"	8316 mm	27'5"
<b>16</b> Reach from Swing Pivot at Ground Line	6043 mm	19'10"	6137 mm	20'2"	7226 mm	23'9"
Maximum Operating Height	6007 mm	19'9"	6075 mm	20'0"	6958 mm	22'11"
Loading Height	3961 mm	13'0"	3921 mm	12'10"	4533 mm	14'10"
<b>17</b> Loading Reach	1855 mm	6'1"	2022 mm	6'8"	3003 mm	9'10"
Swing Arc	180°		180°		180°	
Bucket Rotation	205°		205°		205°	
<b>18</b> Stabilizer Spread, Operating Position (center)	3310 mm	10'10"	3310 mm	10'10"	3310 mm	10'10"
Stabilizer Spread, Operating Position (outside)	3770 mm	12'4"	3770 mm	12'4"	3770 mm	12'4"
Stabilizer Spread, Transport Position	2322 mm	7'7"	2322 mm	7'7"	2322 mm	7'7"
Bucket Dig Force	71 864 N	16,156 lb	70 870 N	15,932 lb	70 870 N	15,932 lb
Stick Dig Force	44 778 N	10,067 lb	43 841 N	9,856 lb	32 414 N	7,287 lb

Dimensions and performance specifications shown are for machines equipped with 12.5/80-18 SGL front tires, 19.5L-24 IT525 rear tires, ROPS canopy, standard stick with 610 mm (24 in) standard duty bucket, 1.0 m<sup>3</sup> (1.31 yd<sup>3</sup>) loader bucket and standard equipment unless otherwise specified.



## Dimensions with Forks

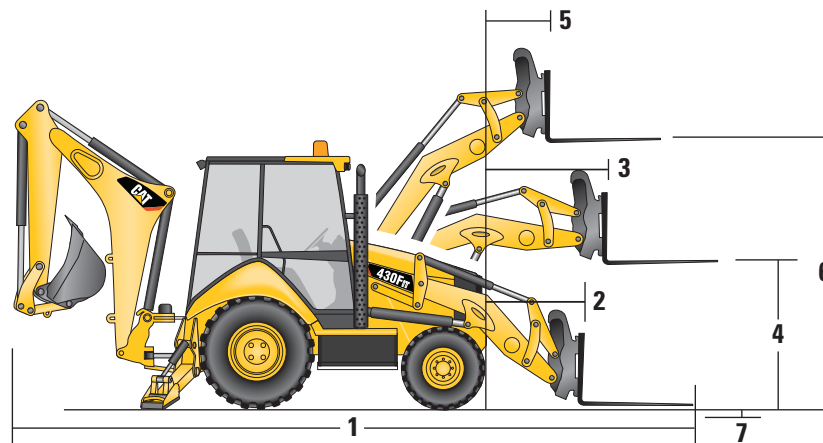

Fork Tine Length	1070 mm/3'6"		1220 mm/4'0"		1370 mm/4'10"	
Operating Load (SAE J1197)	2683 kg	5,916 lb	2583 kg	5,693 lb	2392 kg	5,273 lb
SAE Load Center	535 mm	1'9"	610 mm	2'0"	685 mm	2'3"
Operating Load (CEN 474-4)	2774 kg	6,116 lb	2752 kg	6,067 lb	2728 kg	6,014 lb
CEN Load Center	500 mm	1'8"	500 mm	1'8"	500 mm	1'8"
<b>1</b> Overall Length (forks on ground)	7822 mm	25'8"	7973 mm	26'2"	8121 mm	26'8"
<b>2</b> Reach at Ground (from grill to heel of fork)†	938 mm	3'1"	939 mm	3'1"	937 mm	3'1"
<b>3</b> Maximum Reach (from grill to heel of fork)†	1475 mm	4'10"	1475 mm	4'10"	1475 mm	4'10"
<b>4</b> Fork Height at Maximum Reach	1588 mm	5'3"	1588 mm	5'3"	1587 mm	5'2"
<b>5</b> Reach at Maximum Height (from grill to heel of fork)†	696 mm	2'3"	696 mm	2'3"	696 mm	2'3"
<b>6</b> Maximum Fork Height	3410 mm	11'2"	3410 mm	11'2"	3410 mm	11'2"
<b>7</b> Maximum Fork Depth (below ground level)	-6 mm	-0.24"	-5 mm	-0.20"	-8 mm	-0.31"

Dimensions and performance specifications shown are for machines equipped with 12.5/80-18 SGL front tires, 19.5L-24 IT525 rear tires, ROPS canopy, standard stick with 610 mm (24 inch) standard duty bucket, and 1.0 m<sup>3</sup> (1.31 yd<sup>3</sup>) loader bucket and standard equipment unless otherwise specified.

# 430F/430F IT Specifications

## Dimensions with Material Handling Arm

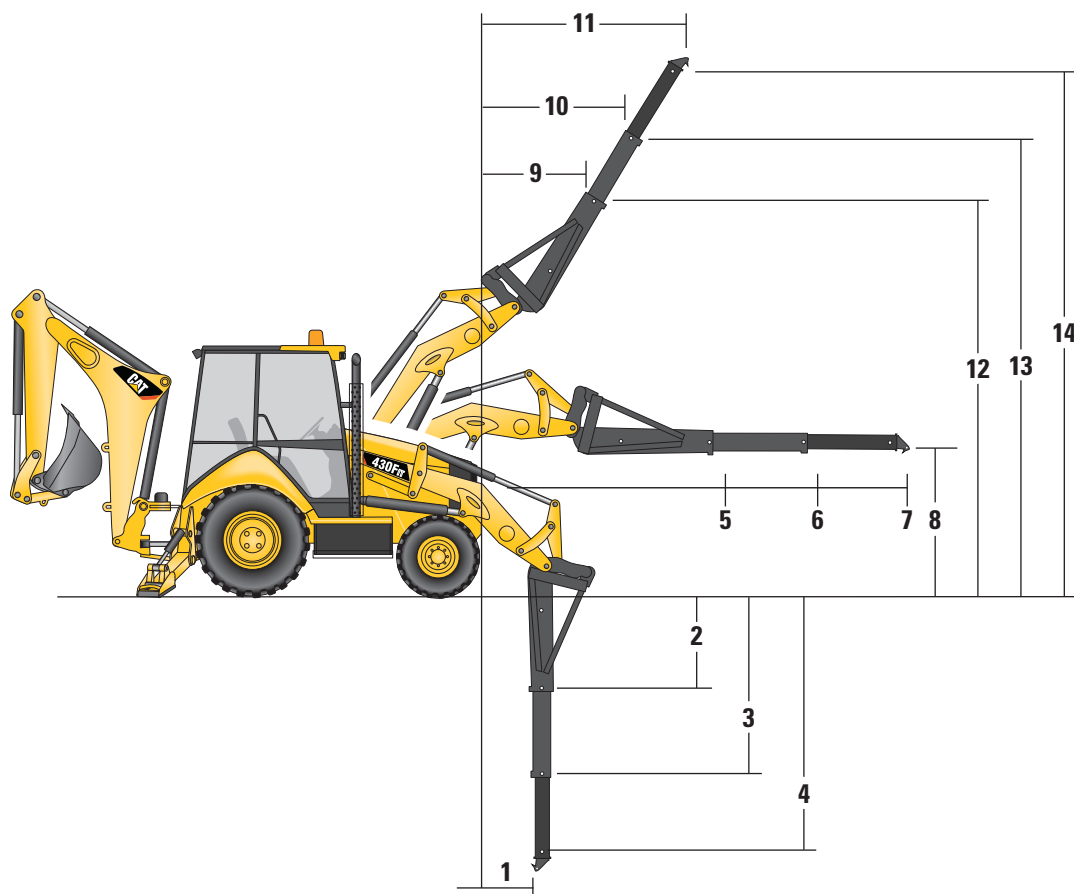

Material Handling Arm Position	Retracted		Mid-Position		Extended	
Operating Load (SAE J1197 and CEN 474-4)*	1058 kg	2,333 lb	674 kg	1,487 lb	495 kg	1,092 lb
Overall Length, Maximum	8867 mm	29'1"	9864 mm	32'4"	10 864 mm	35'8"
<b>1</b> Reach at Maximum Depth (from machine nose)	589 mm	1'11"	592 mm	1'11"	595 mm	1'11"
<b>2, 3, 4</b> Maximum Depth	2532 mm	8'4"	3530 mm	11'7"	4530 mm	14'10"
<b>5, 6, 7</b> Maximum Reach (from machine nose)	3184 mm	10'5"	4182 mm	13'9"	5182 mm	17'0"
<b>8</b> Height at Maximum Reach	1101 mm	3'7"	1103 mm	3'7"	1106 mm	3'8"
<b>9, 10, 11</b> Reach at Maximum Height (from machine nose)	1577 mm	5'2"	2164 mm	7'1"	2755 mm	9'0"
<b>12, 13, 14</b> Maximum Height	4570 mm	15'0"	5377 mm	17'8"	6183 mm	20'3"

\*Hydraulically limited.

Dimensions and performance specifications shown are for machines equipped with 12.5/80-18 SGL front tires, 19.5L-24 IT525 rear tires, ROPS canopy, standard stick with 610 mm (24 inch) standard duty bucket, and 1.0 m<sup>3</sup> (1.31 yd<sup>3</sup>) loader bucket and standard equipment unless otherwise specified.

## Backhoe Lift Capacity

### Cat 430F/430F IT Standard Stick

Boom Lifting		
	kg	lb
1	1508	3,318
2	1782	3,921
3	1936	4,258
4	1925	4,236
5	1878	4,131
6	1819	4,001
7	1757	3,866
8	1698	3,735
9	1641	3,610
10	1588	3,493
11	1539	3,387
12	1496	3,291
13	1459	3,211
14	1432	3,151
15	1425	3,136
16	1503	3,307
17	1573	3,461
Stick Lifting		
	kg	lb
18	2453	5,397
19	2636	5,800
20	2830	6,226
21	2773	6,100
22	2906	6,394
23	3317	7,297
24	5585	12,288
25	5665	12,463

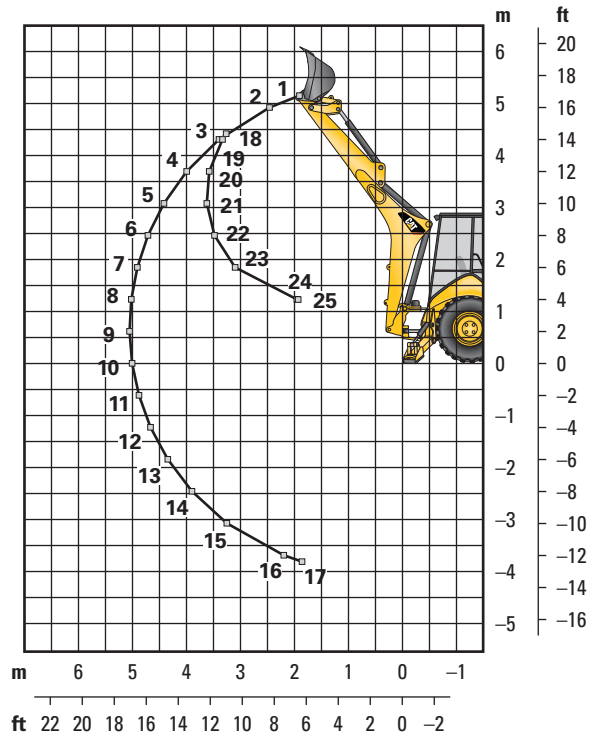

### Cat 430F/430F IT Extendible Stick – Retracted

Boom Lifting		
	kg	lb
1	1250	2,750
2	1543	3,395
3	1667	3,668
4	1658	3,648
5	1615	3,553
6	1561	3,433
7	1503	3,307
8	1447	3,183
9	1392	3,063
10	1341	2,951
11	1294	2,847
12	1252	2,754
13	1215	2,673
14	1187	2,611
15	1175	2,585
16	1223	2,690
17	1330	2,927
Stick Lifting		
	kg	lb
18	2158	4,747
19	2367	5,208
20	2541	5,589
21	2489	5,476
22	2603	5,726
23	2982	6,561
24	4521	9,946
25	6057	13,326

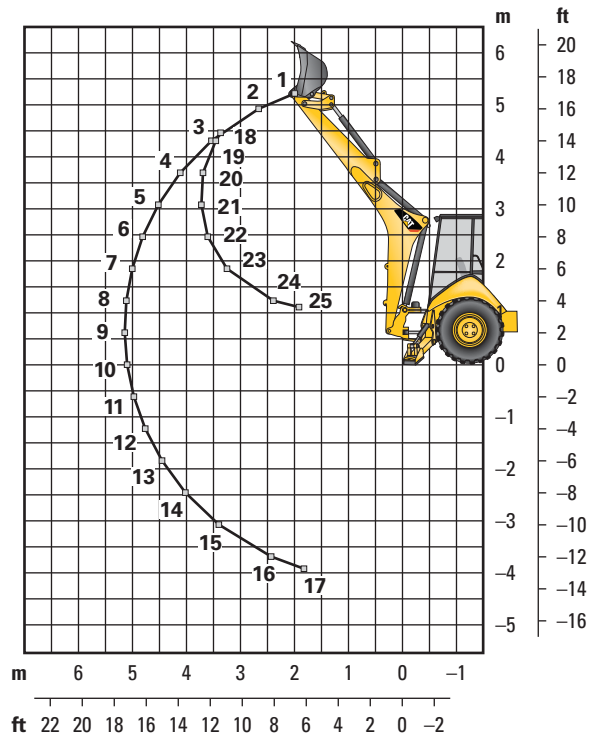

Lift Capacities are over-end values. Machine equipped with 4WD, OROPS, 1.0 m<sup>3</sup> (1.31 yd<sup>3</sup>) general purpose bucket, and 460 kg (1,015 lb) counterweight. Extendible stick includes 488 kg (1,075 lb) counterweight.

# 430F/430F IT Specifications

## Backhoe Lift Capacity

### Cat 430F/430F IT Extendible Stick – Extended

Boom Lifting	kg	lb
1	678	1,492
2	1019	2,241
3	1127	2,480
4	1161	2,554
5	1164	2,561
6	1153	2,536
7	1133	2,494
8	1110	2,443
9	1086	2,389
10	1061	2,335
11	1037	2,282
12	1015	2,233
13	995	2,188
14	978	2,151
15	966	2,125
16	961	2,115
17	970	2,135
18	1013	2,229
19	1222	2,689
Stick Lifting	kg	lb
20	1197	2,633
21	1277	2,810
22	1565	3,444
23	1737	3,822
24	1718	3,779
25	1755	3,861
26	1862	4,097
27	2082	4,581
28	2566	5,645
29	4916	10,814
30	5859	12,890

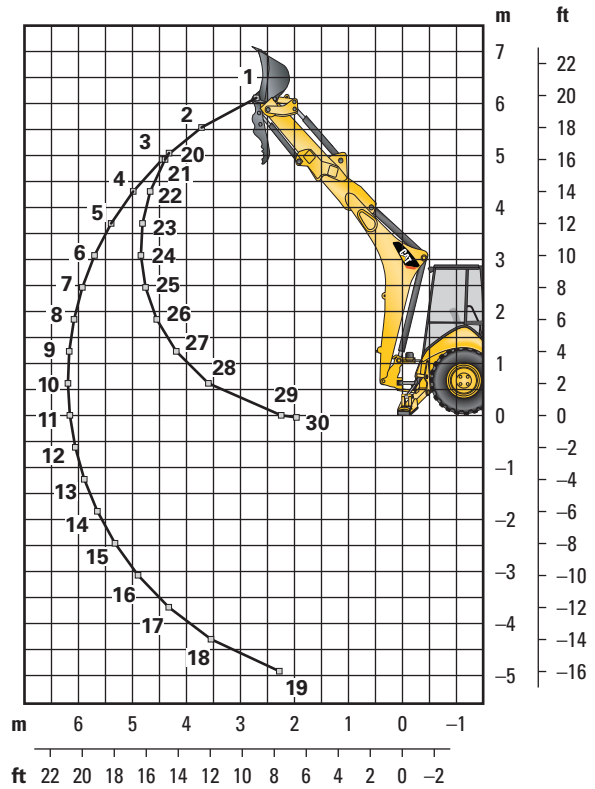

Lift Capacities are over-end values. Machine equipped with 4WD, OROPS, 1.0 m<sup>3</sup> (1.31 yd<sup>3</sup>) general purpose bucket, and 460 kg (1,015 lb) counterweight. Extendible stick includes 488 kg (1,075 lb) counterweight.

## Counterweights

### Minimum Counterweight Recommendations

#### Standard Stick

Loader Bucket	Power Train	Single-Tilt		IT Loader w/QC	
		kg	lb	kg	lb
GP	4WD	460	1,015	115	255
MP	4WD	no counterweight		no counterweight	
Forks	4WD	N/A	N/A	115	255
Material Handling Arm	4WD	N/A	N/A	115	255

#### Extendible Stick

Loader Bucket	Power Train	Single-Tilt		IT Loader w/QC	
		kg	lb	kg	lb
GP	4WD	460	1,015	460	1,015
MP	4WD	460	1,015	115	255
Forks	4WD	N/A	N/A	460	1,015
Material Handling Arm	4WD	N/A	N/A	460	1,015

## Backhoe Buckets

With weld on adapters and pin-on teeth

#### Standard Duty

Width		Rated Capacity		Weight		No. of Teeth
mm	in	L	ft <sup>3</sup>	kg	lb	
305	12	80	2.8	111	245	3
457	18	120	4.2	122	268	4
610	24	180	6.4	141	311	5
762	30	230	8.1	157	345	5
914	36	290	10.2	176	388	6

#### Heavy Duty

Width		Rated Capacity		Weight		No. of Teeth
mm	in	L	ft <sup>3</sup>	kg	lb	
305	12	80	2.8	121	266	3
406	16	110	3.9	128	282	3
457	18	120	4.2	135	299	4
610	24	180	6.4	151	333	5
762	30	230	8.1	177	391	5
914	36	290	10.2	201	443	6

#### Soil Excavation

Width		Rated Capacity		Weight		No. of Teeth
mm	in	L	ft <sup>3</sup>	kg	lb	
457	18	180	6.4	155	341	4
610	24	240	8.5	182	402	5
762	30	320	11.3	206	454	5
914	36	380	13.4	233	513	6

#### Heavy Duty Rock

Width		Rated Capacity		Weight		No. of Teeth
mm	in	L	ft <sup>3</sup>	kg	lb	
305	12	70	2.5	127	279	3
457	18	130	4.6	146	322	4
610	24	200	7.1	174	384	5
762	30	270	9.5	197	434	5
914	36	330	11.7	224	493	6

#### Coral

Width		Rated Capacity		Weight		No. of Teeth
mm	in	L	ft <sup>3</sup>	kg	lb	
305	12	60	2.1	134	295	4
457	18	100	3.5	155	341	6
610	24	140	4.9	182	402	8
762	30	190	6.7	210	463	10

#### Heavy Duty – Pin Lock

Width		Rated Capacity		Weight		No. of Teeth
mm	in	L	ft <sup>3</sup>	kg	lb	
305	12	96	3.4	113	249	3
406	16	123	4.3	131	288	3
457	18	139	4.9	139	307	4
610	24	207	7.3	168	370	5
762	30	275	9.7	194	428	5
914	36	345	12.2	224	494	6

#### High Capacity – Pin Lock

Width		Rated Capacity		Weight		No. of Teeth
mm	in	L	ft <sup>3</sup>	kg	lb	
305	12	96	4.6	113	287	3
406	16	123	5.6	131	327	3
457	18	139	6.5	139	346	4
610	24	207	9.6	168	414	5
762	30	275	12.9	194	475	5
914	36	345	16.2	224	543	6

## Standard Equipment

Standard equipment may vary. Consult your Cat dealer for details.

- Air cleaner
- Alarm, back-up
- Alternator, 150 amp
- Audible system fault alarm
- Automatic Engine Speed Control (AESC)
- Battery, maintenance-free, 880 CCA
- Battery disconnect switch
- Battery remote jumpstart
- Boom transport lock
- Brace, lift cylinder
- Brake, secondary parking
- Brakes, hydraulically boosted, oil disc, dual pedals, interlocking
- Bucket level indicator
- Canopy, ROPS/FOPS
- Cat cushion swing system
- Coat hook
- Coolant/antifreeze, extended life
- Counterweight, bumper
- Diesel particulate filter, long life
- Dome light (cab only)
- Diagnostic port for engine, machine and gauge cluster Electronic Control Modules
- Differential lock
- Engine, Cat C4.4 ACERT (Direct Injection Turbocharged), meets U.S. EPA Tier 4 Interim/EU Stage IIIB emission standards
- Engine enclosure
- Fan, suction and guard
- Fast reversing shuttle, all gears
- Fenders, rear
- Filters, spin-on: fuel, engine oil, transmission oil, water separator
- Filters, bowl and cartridge: hydraulic fluid
- Floor mat
- Flow-sharing hydraulic valves
- Four Wheel Drive/Brake Mode Selector
- Fuel priming pump, electric
- Fully hinged front grill for cooling package cleaning access
- Gauge Cluster:
  - Gauges: coolant temperature, fuel level, tachometer
  - LCD screen: hour meter, torque converter oil temperature, hydraulic oil temperature, operator settings, service mode diagnostics
- Ground level fuel fill
- Guard, fuel tank bottom
- Hazard flashers/turn signals
- High ambient cooling package
- Hood lock
- Hydraulic hose, XT™
- Hydraulic implement lockout
- Hydraulic oil cooler
- Hydraulic oil level sight gauge
- Hydraulic pump, electronic control
- Hydraulic valve, hydrostatic steering
- Hydraulic valves, loader 2 function
- Hydraulic valves, backhoe 5 function
- Hydraulics, load sensing with variable displacement piston pump
- Indicators: air cleaner service, water separator service, engine coolant, oil pressure, hydraulic temperature, hydraulic bypass, torque converter temperature high, remote throttle, AESC, fuel level, charging, engine warning #1, engine warning #2, action lamp, wait-to-start
- Instrument panel lights
- Joystick controls: pilot operated, excavator-style with pattern changer
- Key start/stop system
- Lights, working (4 front, 4 rear)
- Load sensing, variable flow system
- Loader, self-leveling, return-to-dig and transmission disconnect switch
- Loader, single tilt
- Lunch box and drink holder
- Mirror, rearview
- One-touch low idle
- Open circuit breather
- O-ring face seal hydraulic fittings
- Pattern changer, in cab
- Power receptacle, 12 volt, 2 internal, 1 external
- Power steering, hydrostatic
- Seat belt, retractable, 51 mm (2 in)
- Stabilizer shoes, street
- Steering knob
- Seat, air suspension, fabric or vinyl cover, with armrest
- Starting system, glow plugs
- Steering, hydrostatic
- Storage compartment, internal
- Stop and tail lights
- Swing transport lock
- Tilt steering wheel
- Tires
- Toolbox, external, lockable
- Torque converter
- Throttle, hand and foot, electronic
- Transmission, four speed, syncromesh
- Transmission neutralizer switch
- Transport tie-downs
- Vandalism locks
- Warning horn, electric

## Optional Equipment

Optional equipment may vary. Consult your Cat dealer for details.

- Battery, additional, 880 CCA
- Cab, deluxe
- Cab, deluxe with air conditioning
- Cold weather fuel (−30° C/−22° F)
- Cold weather package, including additional battery, engine block heater, radiator antifreeze, cold weather fuel (−30° C/−22° F) and mounting for an ether bottle
- Counterweights, 115 kg (255 lb), 240 kg (530 lb) or 460 kg (1,015 lb)
- Fenders, front with integral steps
- Fenders, rear extensions
- Guard, boom protection plate
- Guard, stabilizer, rock
- Guard, fuel tank front and rear
- Hydraulic valves, loader (3rd valve for GP, MP or Quick Coupler)
- Hydraulic valves, backhoe 6 function
- Hydraulic lines, combined function auxiliary
- Loader, IT with Quick Coupler and pilot loader control
- Machine Security System
- Product Link
- Quick Coupler, manual, dual lock
- Quick Coupler, pin lock
- Radio ready cab
- Ride Control
- Rotating beacon, magnetic mount
- Seat belt, 75 mm (3 in)
- Stabilizer pads, reversible
- Stick, extendible
- Storage box
- Transmission, AutoShift
- Vandalism protection, gauge cover
- Work Tool Attachments such as buckets, forks, material handling arms, augers, hammers, brooms, cold planers and vibratory plate compactors. See your Cat dealer for more information.

# 430F/430F IT Backhoe Loaders

For more complete information on Cat products, dealer services, and industry solutions, visit us on the web at [www.cat.com](http://www.cat.com)

© 2012 Caterpillar Inc.  
All rights reserved

AEHQ6869 (09-2012)

Materials and specifications are subject to change without notice. Featured machines in photos may include additional equipment. See your Cat dealer for available options.

CAT, CATERPILLAR, SAFETY.CAT.COM, their respective logos, "Caterpillar Yellow" and the "Power Edge" trade dress, as well as corporate and product identity used herein, are trademarks of Caterpillar and may not be used without permission.

