

# GH1600

Automated Plow System



## Mining Height

Seam Range	1.0 m-2.3 m	39.3 in-90.5 in
------------	-------------	-----------------

## Coal Hardness

Medium to extremely hard coal

## Power

Maximum Installed Power	2 × 800 kW	2 × 1,080 hp
Maximum Plow Speed	3.6 m/sec	720 fpm

## Cutting

Maximum Cutting Depth	210 mm	8.27 in
-----------------------	--------	---------



## Features

### **Most Advanced Low Seam Longwall System in the World**

*Combines high installed power with unique features like overload protection, horizon control and incremental plowing.*

### **Lowest Total Cost of Ownership**

*Setting the standard for mining coal seams below 1.8 meters (90 in).*

### **Industry's Most Advanced Remote Control System**

*No operator required in the face during operation.*

### **No Out-of-seam Dilution**

*Positive environmental impact by minimizing refuse requiring disposal.*

### **Technology that Delivers Sustainability**

*Opens new coal reserves that were previously classified as uneconomical to mine.*

## Contents

The Principle of Plowing.....	4
Plow Guide.....	6
Plow Body.....	6
Horizon Control.....	7
Drive System.....	8
Control System.....	9
Incremental Plowing.....	10
Plow Line Pans.....	11
Plow Roof Supports.....	12
Safety.....	13
Serviceability.....	13
Specifications.....	14
Notes.....	19

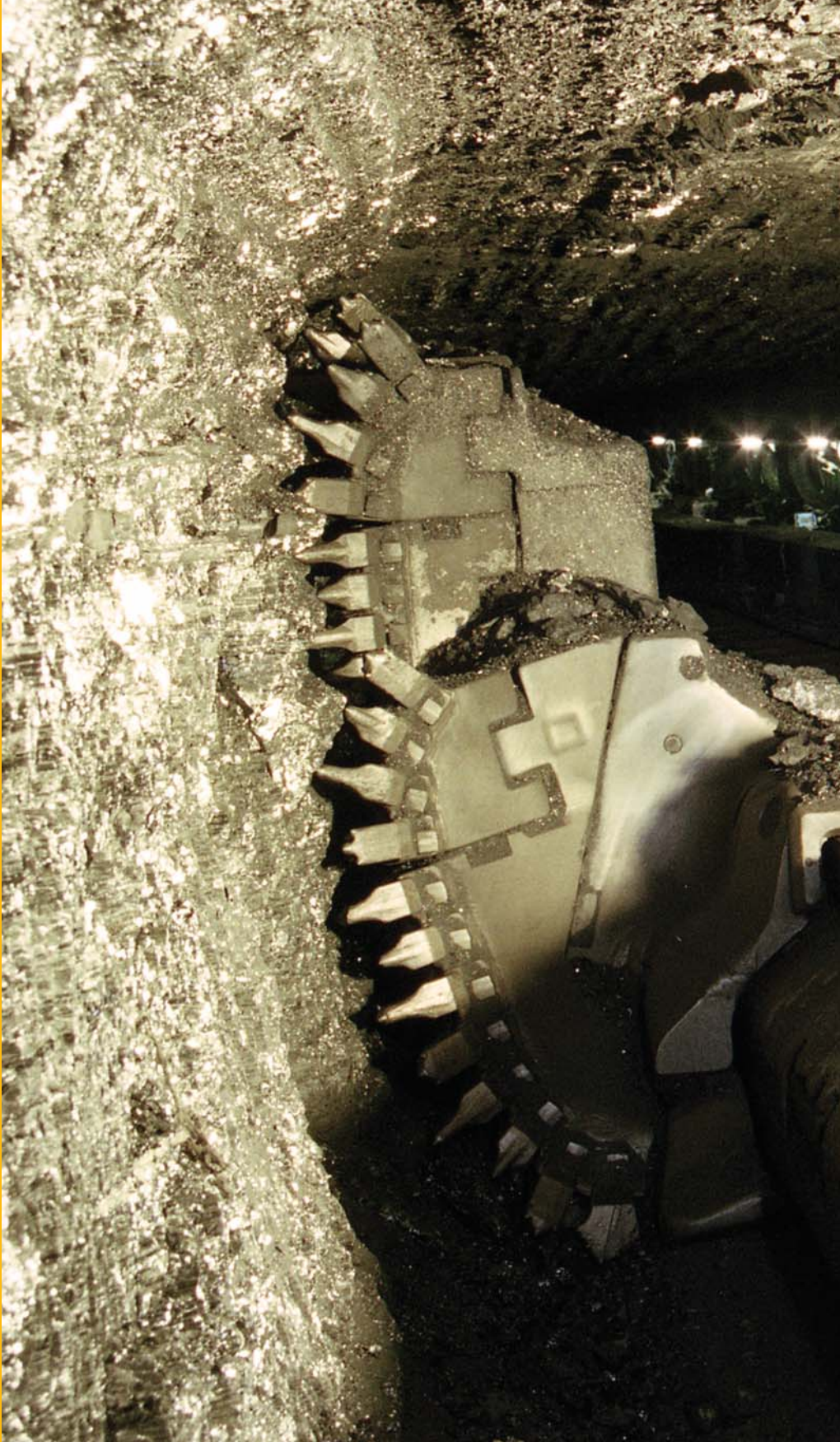





**The Gleithobel Plow System GH1600 was specifically developed for very hard coal and high productivity by doubling the installed power of the GH800 to 1600 kW (1,080 hp). It can be used in seams from approximately 1.0 m (39 in) up to 2.53 m (91 in) with a portal arm.**



# The Principle of Plowing

Highest performance in low coal

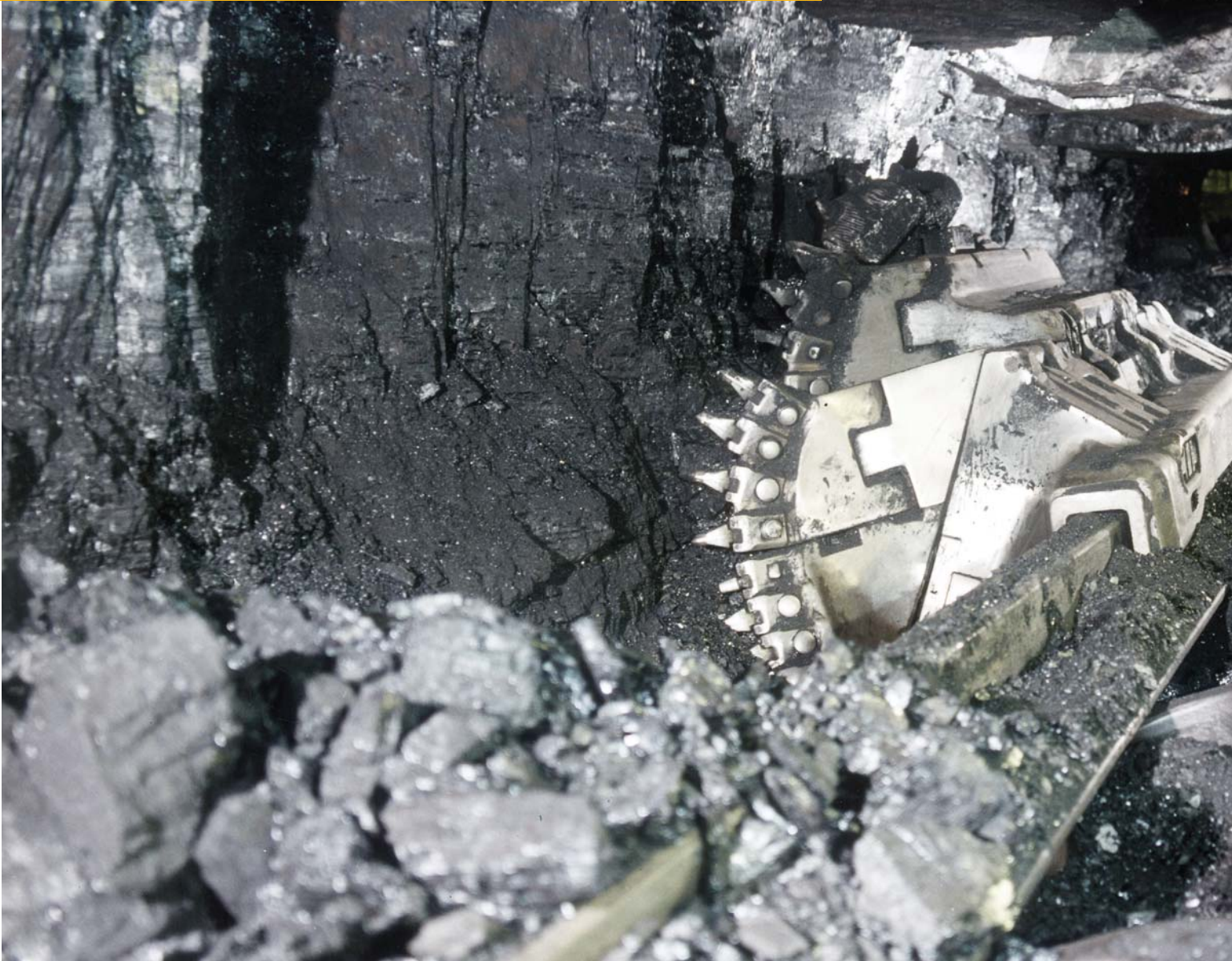

## System of Choice

The removal rate achieved by plows compared to shearers has continued to increase over the years.

For seams with an average height under 1.8 m (70 in), plows are now the system of choice for longwall mining. But the GH1600 can mine up to 2.5 m (98.4 in). In seams from 1.8 to 2.3 m (90.5 in), the choice of plow or shearer depends on the geological conditions.





We have been designing and building longwall plows since 1941 – and things have come a long way. Technical advances since 1990 have once again established plowing as the preferred longwall mining method for seams below 1.8 m (70 in). Cat® plows offer world-leading features that other manufacturers cannot and a cost of ownership that far outstrips the shearer when mining thin and medium seams. Their reliability, high-productivity and ability to mine in-seam make them the ideal choice for longwall mining medium and thin seams.

### **World-leading Features**

Cat plows offer world-leading features that other manufacturers cannot offer – and cost per tonne (ton) that far outstrips shearer performance in thin and medium seams, making them reliable, high-productivity longwall mining systems for medium and thin seams, like the Gliding Plow System GH1600.

### **How It Works**

The plowing principle is simple: A sculpted steel plow body equipped with strategically-placed cutting bits is pulled along the face conveyor from one end of the face to the other by a continuous loop chain powered by drives located at the face ends. Cutting depth is electronically controlled by pushing the AFC toward the coal ace in preselected increments after the plow has passed.

### **Height-adjustable**

The height of the plow body is easily and completely adjustable within a certain range, ensuring that only coal is cut. The plow body height can also be adjusted in larger increments by installing or removing additional bit blocks. Both adjustments can be performed quickly and easily from the gob-side.

### **Remote Control**

No operator is required at the longwall face itself. Operation can be controlled from a central control station either underground – for example, at the head gate entry – or on the surface, so operators can work remotely in a dirt- and dust-free area. The outrigger steering system provides vertical horizon control. Steering is normally controlled manually, but can be automated. Shields are positioned to suit the longwall's geology and normally advance automatically with the cutting action of the plow.





# Plow Body

## Reduction of wear and tear

Typically the single Gleithobel plow body is used, attached to the bottom chain. Every point of contact between plow body and plow guide is designed as a wear part.

### Height-adjustment

The modular design allows the height of the plow body to be adjusted by simply inserting or removing bit blocks with a height of 265 mm (10 in) each. The plow body can also be adapted to smaller variations in seam height through an infinite height adjustment by means of a bit turret built into the plow body. The turret carries the top bits of the plow and can be precisely raised or lowered up to 300 mm (12 in) by means of a worm gear accessible from the gob-side.

### Shock Absorber

Caterpillar has developed an innovative shock absorber to provide added protection for the plow and chain. The elastic coupling inserted into the plow pulling sledge contains elastomers with properties that reduce the peak forces applied to the chain. This results in smoother plow operation, minimizing loads on the plow chain, the plow connectors and the drives, thereby extending their effective service life.

### Benefits

- Reduces wear and tear on plow, drives and chain
- Smooth plow operation extends overall service life

# Plow Guide

The plow guide is cast to withstand the high reaction forces resulting from the powerful drives. The plow guide is designed to generate minimum friction between the plow guide and plow chain. Doors inside the plow guide (at every second pan) can be opened for quick and easy access to both top and bottom chain. Both gob-side and face-side pan connectors have a breaking strength of 3600 kN (400 tons) with the special PF 4 plow line pan modified for the use with this plow system.







## Horizon Control

### Controlling the coal seam



Effective plow horizon control is necessary to cope with undulations in the coal seam. Following the coal seam minimizes cutting of adjacent rock strata and the associated preparation costs, reduces cutting tool (bit) consumption and reduces power consumption while maximizing seam recovery. Caterpillar has developed an outrigger steering system for vertical horizon control with hydraulic cylinders between the gob-side of the AFC and the roof support's relay bar.

Extending the cylinder promotes a downward (digging) cutting direction of the plow, retracting promotes an upward (climbing) direction. The steering cylinders can be controlled either manually or automatically via the Cat PMC-R electro-hydraulic control system. A block anchorage system consisting of cylinders installed between face conveyor and roof support at the face ends controls conveyor creep and helps maintain the correct plow chain tension.



#### Benefits

- The plow advances in relatively small increments compared to a shearer. This allows the horizon control system to vertically steer the plow, keeping it in the seam even where seam undulations are severe. A shearer can only make gradual changes in vertical alignment, resulting in higher "out-of seam" dilution in severely undulating conditions.
- Easy height adjustment allows plows to work smoothly through faults or undulations, minimizing the cutting of adjacent strata.





# Drive System

Maximum power with total control



## Load Sharing

Variable Frequency Drive (VFD) motors allow speed to be varied between 0 and 120% of nominal while maintaining constant torque throughout a wide range of speeds. Power consumption on the motors is constantly monitored to allow load sharing between the individual drives.

## Benefits

- Full utilization of available power
- Prevention of motor overheating and resultant downtime
- Reduced motor current with optimum torque during startup
- Excellent power factor (~1)

## Overload Protection

Effective overload protection is essential for fast, high-power plowing. The Cat planetary UEL overload protection system has an integrated multi-disc clutch with the pressure set to allow the clutch to slip well below the torque required to reach the breaking strength of the chain. If “clutch slip” is sensed, the gearbox torque is immediately decreased, combined with a simultaneous shutdown of the plow motors to prevent damage to the chain.

## Benefits

- Eliminates shock loads from all drive components
- Minimizes chain failures and maximizes component life
- Allows for a quick system restart

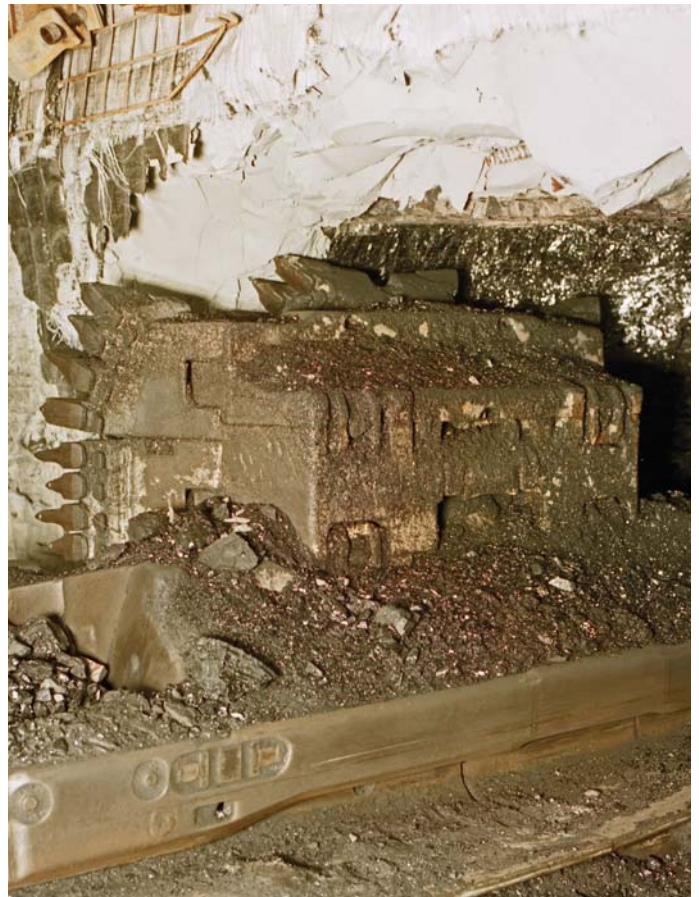



# Control System

## Intelligent control of plow performance

### Plow Control

As the plow has no moving parts, plow control is achieved using a separate PMC-D drive control. The PMC-D determines the plow position precisely and reliably by measuring drive chain travel. The PMC-D is typically used in conjunction with a PMC-V, which provides the human-machine interface (HMI) and visualization.

### PMC-D (Drive Control Unit)

The PMC-D Drive Control Unit is the core of the PMC-D system. Typically dedicated to a gearbox or drive, the unit is normally mounted close to the device or application it controls. The PMC-D unit has all the hardware required to effectively control the many functions of a typical drive system.



### PMC-V (Visualization and Control Unit)

The VCU not only controls the entire longwall, but also visualizes face operations on a graphic display, including position, actual coal load on the AFC (through AFC power consumption), shield position, leg pressure, stroke and plow position. The VCU provides a face-wide network and allows remote maintenance of shield components as well as data recording and transfer of data to the surface.

The PMC-V provides an operator interface to all installed PMC-D system units. It allows the operator to set parameters, and to store and view system data. The PMC-V has 24 keys for easy operation and includes a 4" VGA display for data visualization. Graphic trending and any warnings and error messages can also be clearly displayed.

With a choice of interface languages, the PMC-V display shows all data available from the gearboxes, including transducer values, status information, global and local parameters, and network status.

**VPlow** visualizes the plow system including all plow movements and progress as well as all parameter settings especially of the overload-protected drive control.

**VDrive** visualizes the conveyor gearbox controllers and allows parameter setting. Sensor values can be displayed graphically.



# Incremental Plowing

Highest safety and productivity in low coal

## Incremental Plowing

The key requirements for high-performance plowing are remote control, adjustable cutting depth and the ability to maintain a straight face line. These requirements are all achieved by the Cat incremental cutting system and the fully automated plow longwall system. With conventional plows, variations in coal hardness lead to variations in cutting depth that often result in overloading of the conveyor and downstream equipment or jamming of the plow. Incremental plowing prevents these problems by keeping the depth of cut constant regardless of coal hardness or presence of rock bands.

### Benefits

- Remote operation allows highest safety and maximum productivity in low coal.
- The AFC/plow system and roof supports can be positioned exactly where they are needed (snakes, roof condition, faults, etc.).
- System is self-correcting for over push and under push, keeping the face straight regardless of conditions.
- Optimum use of installed power for maximum cutting depth for every area of the face.
- Automated Cat plow systems allow access to extended reserves in low coal seams to achieve a higher percentage of reserve recovery.
- Significantly more coal can be mined with more efficient layouts, reducing overall costs.





# Plow Line Pans

## State-of-the-art conveyor technology

### Optimized Contact Surfaces

The use of the proven PF profile in the top race maximizes the contact surface between the flight bar and the profile. This minimizes the flight bar surface pressure in snakes and undulating seams. Special shaping of the bottom race – which almost doubles the contact surface – substantially reduces both friction and wear of the flight bar shoulder. Also, the curved transition at the pan ends greatly reduces noise during operation of the chain conveyor.

### Benefits

- Minimal friction
- Low wear of flight bar shoulder in the bottom race
- Minimized power losses
- Longer service life of flight bars and profiles
- Lower noise level during operation

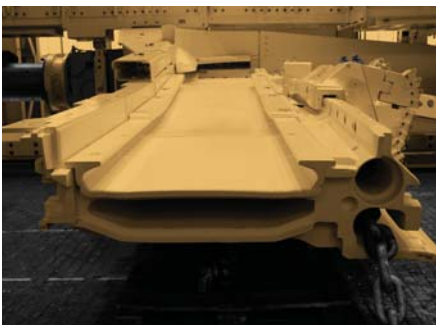

### Line Pans

The innovative Cat PF plow line pans define the state of the art for underground face conveyor technology. They are based on the tried-and-tested PF3 and PF4 generations, which meet all requirements regarding quality, wear resistance and conveying capacity. PF line pans form the powerful backbone of the conveyor system. The pioneering conveyor technology and extremely rugged pan design have been subjected to extensive testing.

### Separation of Wear Parts

The smart and totally new idea of splitting up the different functional areas in the PF allows the separation of wear parts from structural parts. Very hard, wear-resistant materials are used for parts subject to wear, while the structural parts are made of tough, high-strength steels. The pan design allows problem-free replacement of worn-out top troughs.

### Benefits

- Substantially longer service life
- Considerably lower overall pan wear
- Easy underground replacement of wear parts



# Plow Roof Supports

Maximum protection underground



## Roof Supports

Roof supports for plow systems working in thin seams have special requirements and restrictions:

- Direct-acting DA ram allows the use of shorter roof supports to cope with undulating seams.
- Only high-strength steel is used for structural components to ensure minimum thickness and maximum travelway height.
- A split base allows the vertical movement of the relay bar necessary for effective horizon control and access to the DA ram for maintenance.
- Elephant step is available to prevent dirt accumulation and overcome soft floor conditions.

## Electronic Roof Support Control System

The modern, reliable and easy-to-operate electro-hydraulic PMC-R shield control systems are designed, manufactured and programmed by Caterpillar. Their primary function is automation of the cutting process using incremental plowing. Two configurations are possible: A control in each shield (typically used) or one control shared by three shields in cases where fewer shield functions are required.





# Serviceability

Easy underground replacement of wear parts

## Maximum Uptime and Service Life

The plow body consists of mechanical components with all wear parts capable of being replaced underground.

The trough is designed for easy underground replacement of worn-out top troughs.

## Caterpillar Global Customer Service

At Caterpillar, our relationship does not end with the sale of new equipment – it is just the beginning of a long-term partnership. We offer full life-cycle customer service with every purchase. When you invest in Cat equipment, you invest in productivity.

The global Cat dealer network offers service and support packages include field service, repairs, overhauls and superior-quality OEM parts, ensuring the best long-term return on investment. Our goal is to constantly maximize customer productivity. We achieve this by remaining on the cutting edge of mining technology, providing customers with the best equipment with the lowest life-cycle costs.

Caterpillar Global Customer Service ensures that your mining equipment remains a highly productive asset.

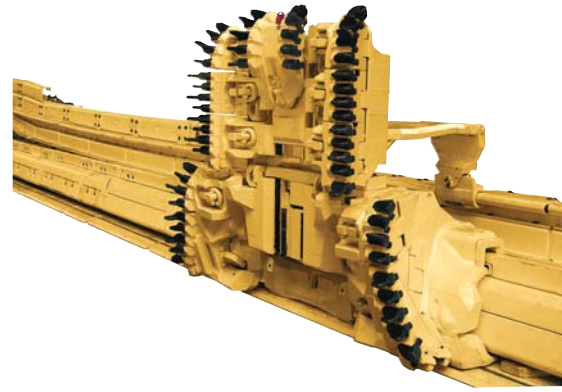

# Safety

Maximum protection of men and machine

## Safety and Productivity

- Remote operation with no operators at the face. Highest safety standards, maximum productivity in low coal (independent from operators traveling speed).
- Automated operation increases safety and face management as the result of constant monitoring and visualization, clear and consistent documentation and analysis, and constant process improvement.





# **GH1600 Automated Plow System Specifications**

<b>Technical Data</b>		
Plow Length	2969 mm	9.74 ft
Plow Heights	980-1230 mm	3.22-4.04 ft
	1180-1480 mm	3.87-4.86 ft
	1445-1745 mm	4.73-5.73 ft
Plow Heights (with gobside support)	1860-2160 mm	6.10-7.08 ft
Mechanical Height Adjustment	180-300 mm	0.59-0.98 ft
Cutting Depth	210 mm	0.69 ft
Weights	5600- 8600 kg	12,345- 18,960 lb
<b>Bottom Bit Positions</b>		
Position 1	+12 mm	+0.04 ft
Position 2	-10 mm	-0.03 ft
Position 3	-21 mm	-0.07 ft
Position 4	-35 mm	-0.11 ft
Maximum Drive Power	2 × 800 kW	2 × 1,080 hp



## Dimensions – Plow Body Setup Option 1

All dimensions are approximate.

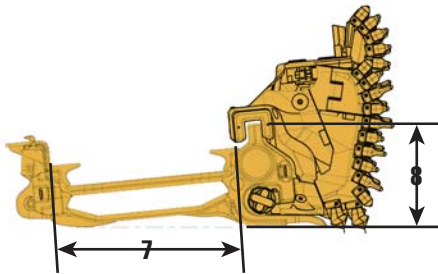
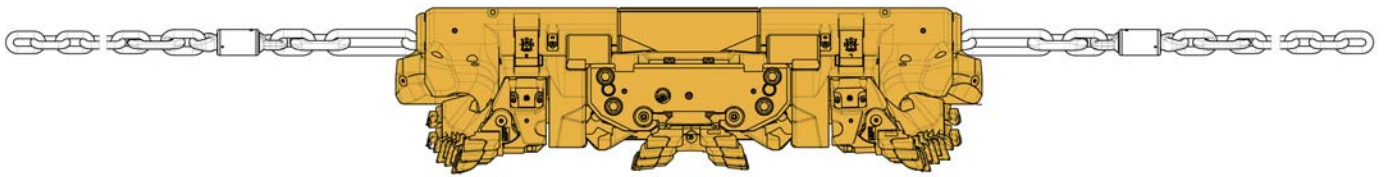
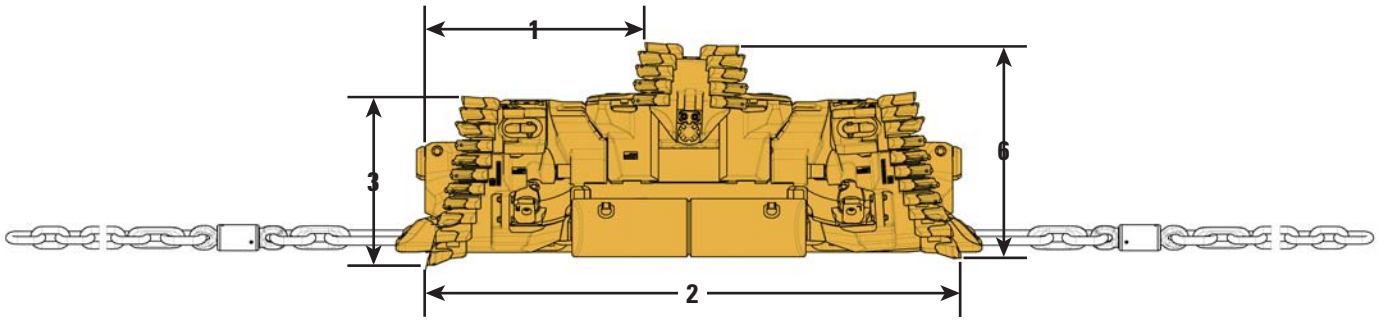

<b>1</b>	1211 mm	3.97 ft	<b>5</b>	–	–
<b>2</b>	2969 mm	9.74 ft	<b>6</b>	1230 mm	4.04 ft
<b>3</b>	931 mm	3.05 ft	<b>7</b>	1032 mm	3.38 ft
<b>4</b>	–	–	<b>8</b>	578 mm	1.89 ft



# GH1600 Automated Plow System Specifications

## Dimensions – Plow Body Setup Option 2

All dimensions are approximate.

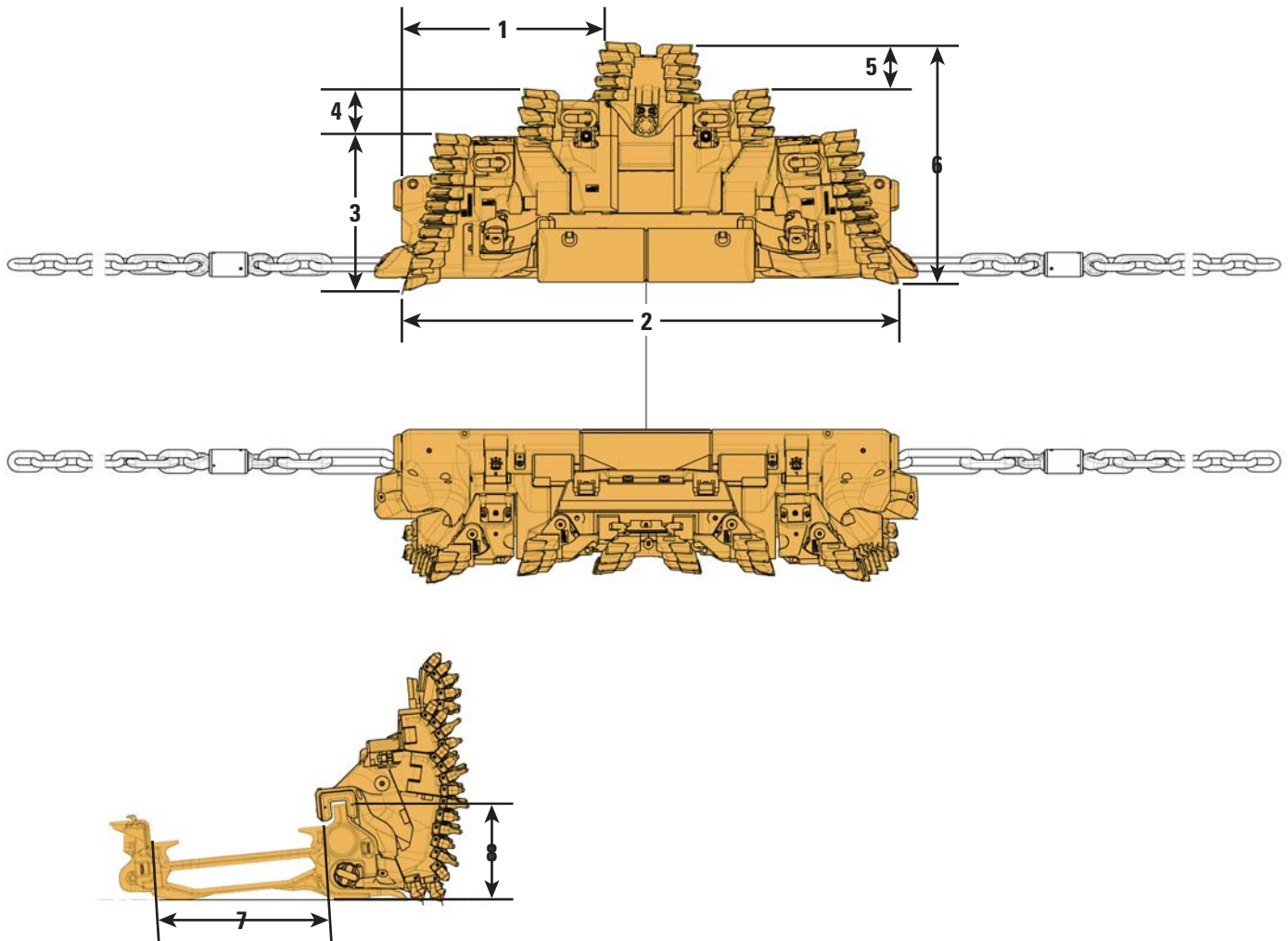

<b>1</b>	1211 mm	3.97 ft	<b>5</b>	285 mm	0.94 ft
<b>2</b>	2969 mm	9.74 ft	<b>6</b>	1480 mm	4.86 ft
<b>3</b>	931 mm	3.05 ft	<b>7</b>	1032 mm	3.38 ft
<b>4</b>	264 mm	0.87 ft	<b>8</b>	578 mm	1.89 ft



## Dimensions – Plow Body Setup Option 3

All dimensions are approximate.

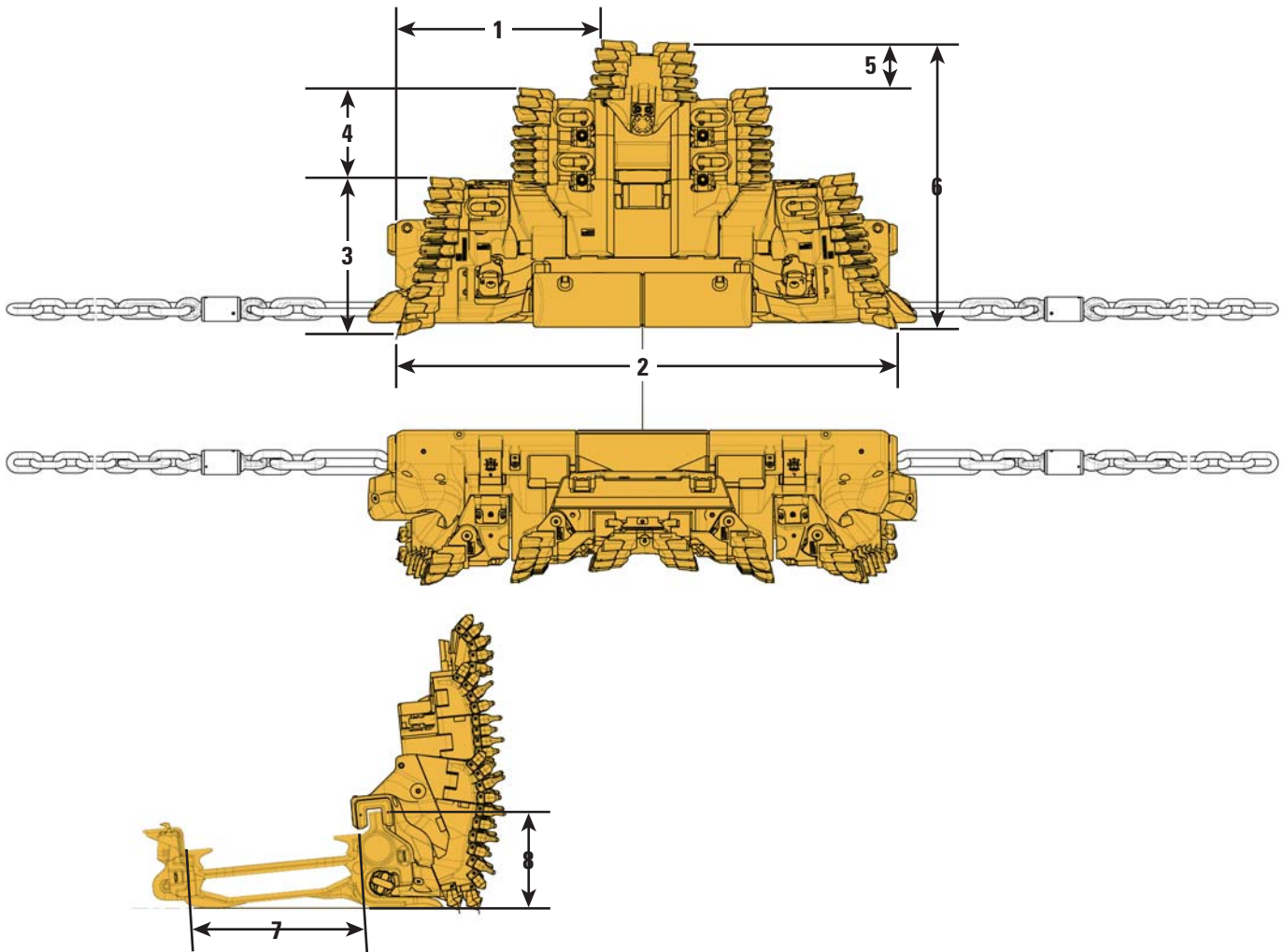

<b>1</b>	1211 mm	3.97 ft	<b>5</b>	285 mm	0.94 ft
<b>2</b>	2969 mm	9.74 ft	<b>6</b>	1745 mm	5.73 ft
<b>3</b>	931 mm	3.05 ft	<b>7</b>	1132 mm	3.71 ft
<b>4</b>	529 mm	1.74 ft	<b>8</b>	578 mm	1.89 ft

# GH1600 Automated Plow System Specifications

## Dimensions – Plow Body Setup Option 4

All dimensions are approximate.

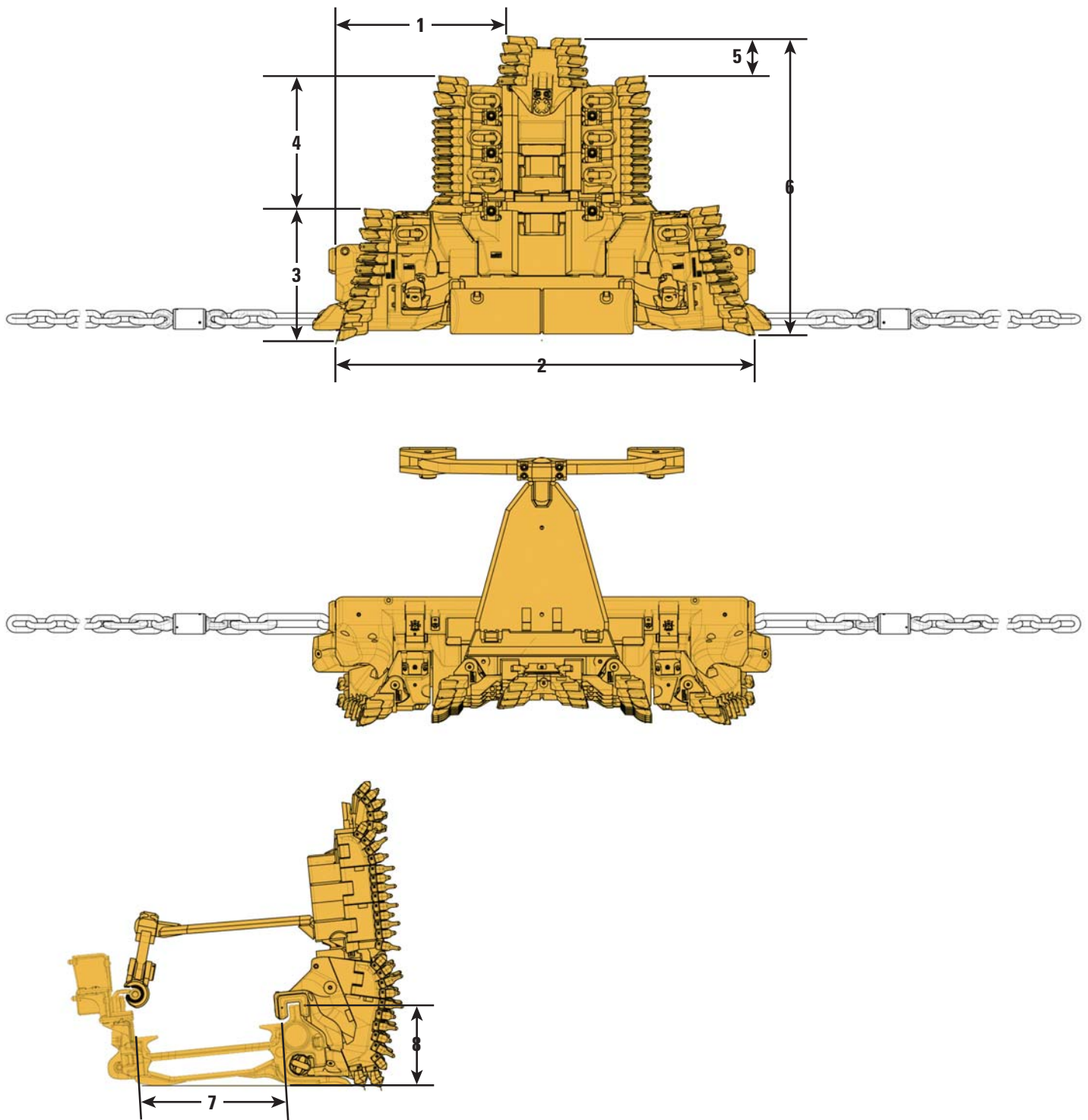

<b>1</b>	1211 mm	3.97 ft	<b>5</b>	285 mm	0.94 ft
<b>2</b>	2969 mm	9.74 ft	<b>6</b>	2160 mm	7.09 ft
<b>3</b>	931 mm	3.05 ft	<b>7</b>	1132 mm	3.71 ft
<b>4</b>	944 mm	3.10 ft	<b>8</b>	578 mm	1.89 ft





For more complete information on Cat products, dealer services, and industry solutions, visit us on the web at [www.cat.com](http://www.cat.com)

AEHQ6803-01 (01-2013)  
Replaces AEHQ6803

© 2013 Caterpillar Inc.  
All rights reserved

Materials and specifications are subject to change without notice. Featured machines in photos may include additional equipment. See your Cat dealer for available options.

CAT, CATERPILLAR, SAFETY.CAT.COM, their respective logos, "Caterpillar Yellow" and the "Power Edge" trade dress, as well as corporate and product identity used herein, are trademarks of Caterpillar and may not be used without permission.

