



Cat[®]

7495 HF

with Rope Crowd

ELECTRIC ROPE SHOVEL

Specifications

Dimensions

Dipper payload (Available dipper payloads up to 109 tonnes [120 tons] when specified)	100 tonnes	110 tons
Dipper capacity	30.6-61.2 m ³	40-80 yd ³
Length of boom	20.4 m	67 ft
Effective length of dipper handle	10.9 m	35 ft 10 in
Overall length of dipper handle	14.3 m	47 ft

Weights

Working weight, with dipper and standard links	1 429 120 kg	3,150,670 lb
Net weight, domestic, without ballast or dipper	1 045 902 kg	2,305,820 lb
General purpose dipper 56 m ³ (73 yd ³)	80 603 kg	177,700 lb
Ballast (furnished by customer)	302 614 kg	667,150 lb

- These weights will vary slightly depending upon dipper and optional equipment selection.

Main Structures

Crawler Mounting

Overall width 317.5 cm (125 in) treads, standard	12.73 m	41 ft 9 in
Overall length of mounting	11.43 m	37 ft 6 in
Overall width 355.6 cm (140 in) treads	13.5 m	44 ft 3 in
Total effective bearing area (317.5 cm/125 in treads)	57.13 m ²	615 ft ²
	245 kPa	35.6 psi
Total effective bearing area (355.6 cm/140 in treads)	64 m ²	689 ft ²
	219 kPa	31.8 psi
Number and diameter of rollers		
Lower (16)	79.4 cm	31.25 in
Lower rear (2)	106.7 cm	42 in
Upper	Slides	
Take-up tumblers diameter	162 cm	63.8 in
Number and pitch of treads (94)	50.8 cm	20 in

Planetary Propel

- Dual-motor independent drive.

Revolving Frame (Center Section)

Welded, impact-resistant steel		
Length	8.38 m	27 ft 6 in
Width	3.68 m	12 ft 1 in

Main Structures (cont'd)

Turntable

Forged rim, alloy steel swing rack pitch diameter	5.26 m	17 ft 3 in
Teeth external cut (face)	24.13 cm	9.5 in
Tapered, forged alloy steel roller rails diameter	4.52 m	14 ft 10 in
Number of tapered rollers	50	
Tapered rollers diameter	27.31 cm	10.75 in

Swing

- Two planetary gearboxes, each driven by a vertically mounted motor, are mounted on either side of the revolving frame. Dual-output pinion shafts from each gearbox engage the swing rack.

Hoist

- A planetary gearbox with dual-output pinions provides the hoist torque transfer from the electric motor to the hoist drum gear.

Lube System

- Single-line system applies lubricant and grease via the PLC.
- 6 pumps (4 for lubricant and 2 for grease) located in an insulated, double-walled lube room.

Electrical

Drive

- IGBT Acutrol drive system.

Power Requirements

Voltage	3 phase, 50/60 Hz, 7,200V
Average 15-minute demand	926-1297 kW
Peak power	3706 kW

- Other voltage options available to suit customer requirements.

Distribution System Requirements

Machine on separate system	4000 kVA
----------------------------	----------

Main Electrical Systems

System voltage (nominal)	50/60 Hz, 7,200V
Trail cable (furnished by customer)	SHD-3-#1/0 at 8,000V
Transformer, auxiliary	350 kVA, 7,200V primary
Lighting transformer	2 at 25 kVA, 120/240V secondary



7495 HF with Rope Crowd Electric Rope Shovel

Lights

- HPS lights on boom feet, top of A-frame, machinery house, lube room, control room, utility room and flood lights.
- Incandescent lights on ground lights, walkways and operator's cab.

Front End

Boom

Boom	welded, impact-resistant steel	
Boom point sheaves	twin-grooved, flame-hardened	
Boom point sheave diameters	243.84 cm	96 in
Handle diameter	86.36 cm	34 in
Wall thickness (nominal)	7.62 cm	3 in

Front End (cont'd)

Rope Data

	No.	Diameter	Type	Construction
Hoist	2	69.8 mm (2.75 in)	twin dual	8 × 37
Crowd	1	63.5 mm (2.5 in)	single dual	8 × 37
Retract	1	63.5 mm (2.5 in)	single dual	8 × 37
Boom susp.	4	82.6 mm (3.25 in)	equalized	struct. strand
Dipper trip	1	19.1 mm (0.75 in)	single	7 × 25

Crowd

- Rope Crowd with crowd machinery located at the front center of the revolving frame, consisting of motor, brake, drum and gearing. Plastic-coated crowd and retract ropes are used to move the dipper handle fore and aft.

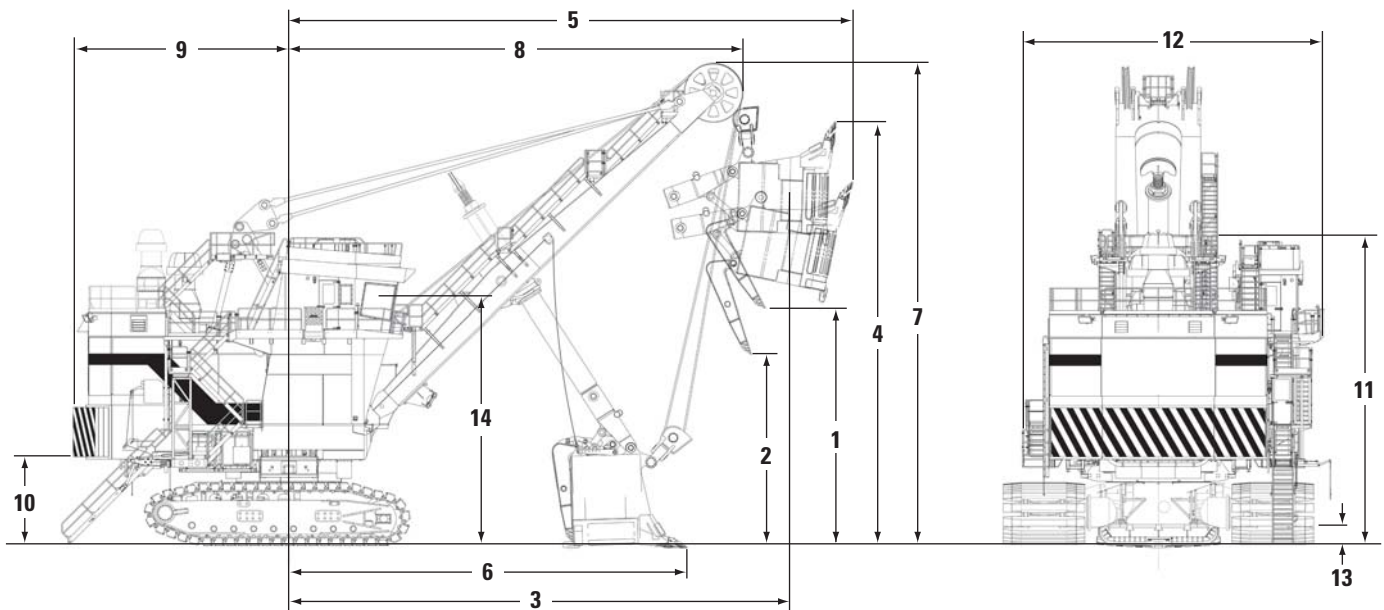

Optimal Working Ranges

1 Dumping height	10.06 m	33 ft 0 in	8 Clearance radius (boom point sheaves)	19.65 m	64 ft 5 in
2 Dumping height at maximum electric crowd limit	8.61 m	28 ft 3 in	9 Clearance radius (revolving frame) (max.)	9.34 m	30 ft 8 in
3 Dumping radius (maximum)	21.64 m	71 ft 0 in	10 Clearance under frame (to ground)	3.76 m	12 ft 4 in
4 Cutting height (maximum)	17.8 m	58 ft 5 in	11 Height of A-frame	14 m	46 ft 0 in
5 Cutting radius (maximum)	25.2 m	82 ft 8 in	12 Overall width	13.96 m	46 ft 1 in
6 Radius of level floor	17.47 m	57 ft 4 in	13 Clearance under lowest point in truck frame/propel gearcase	0.90 m	2 ft 11.5 in
7 Clearance height (boom point sheaves)	20.87 m	68 ft 6 in	14 Operator's eye level	10.61 m	34 ft 10 in

For more complete information on Cat products, dealer services, and industry solutions, visit us on the web at www.cat.com

© 2013 Caterpillar
All Rights Reserved
Printed in U.S.A.

Materials and specifications are subject to change without notice. Featured machines in photos may include additional equipment. See your Cat dealer for available options.

CAT, CATERPILLAR, SAFETY.CAT.COM, their respective logos, "Caterpillar Yellow" and the "Power Edge" trade dress, as well as corporate and product identity used herein, are trademarks of Caterpillar and may not be used without permission.

AEHQ6520-01 (02-13)
Replaces AEHQ6520

