

# CD54

Vibratory Asphalt Compactor

**CATERPILLAR**<sup>®</sup>



#### **Cat<sup>®</sup> 3054 DIT Engine**

Max. Gross Power	74.5 kW	99.5 hp
------------------	---------	---------

#### **Operating Weights w/ROPS/FOPS Cab**

Standard Operating Weight	9500 kg	20,944 lb
Maximum Operating Weight	10 900 kg	24,030 lb

#### **Compaction Width**

Drum Width	1700 mm	67 in
Max. Compaction Width	3000 mm	118 in

## CD54 Features

### Versatile Steering

*Multiple steering options and sensitive to the touch operation enhance operator control and reaction to obstructions.*

### Application Versatility

*The combination of the versatile Cat® vibratory system and wide offset drum lets you configure your machine to precisely match job requirements.*

### Smooth Working Powertrain

*The liquid cooled Cat® 3054C DIT engine offers more power, while responsive controls and smooth operation build operator confidence.*

### Comfortable Operation

*Low sound levels, cool operating environment and good visibility provide a high level of comfort.*

### Reliable Water Spray System

*Spray bar operation with continuous or intermittent mode gives the operator flexibility to conserve water, yet perform well in the most unfavorable operating conditions.*

### Simplified Service

*The Electronic Control Modules (ECMs) provide easy diagnostic capability.*



### Contents

Performance .....	3
Vibratory System .....	4
Water Spray System .....	4
Split Drums .....	5
Steering .....	5
Powertrain .....	6
Operating Environment .....	7
Service Features .....	8
Customer Support .....	8
Specifications .....	9,10
Optional Equipment .....	10
Dimensions and Weights .....	11

**The Cat® CD54 Drum Steer Asphalt Compactor offers a versatile vibratory system that produces results on all types of asphalt mix. From tender to harsh mixes, this Cat asphalt compactor delivers the right amount of force to achieve density without compromising smoothness or productivity. The front and rear split drums, wide offset feature, optimum maneuverability, power, and reliable water spray system deliver unmatched performance in adverse conditions. Excellent visibility to the drum edges ensures precise control when operating against obstacles and matching joints. The operating station provides the comforts and all-around visibility that you've come to expect from Caterpillar.**

# Performance

Compactor design delivers unmatched versatility.

Meeting density and smoothness specifications can often be challenging. Caterpillar understands this, and designs asphalt compactors that simplify operation, yet provide versatility to perform in all types of applications. Having the right equipment and understanding its capability will help you meet those performance requirements for every situation that you encounter.

## Superior Mat Finish

Maneuverability and dealing with tight corners is a common challenge for all asphalt compactors. Maneuvering on the mat to finish a pass or follow a radius can often result in tearing of the mat surface. The Cat CD54 with an exclusive split drum design, permits tight turns and significantly reduces tearing so the operator is free to concentrate on pattern accuracy and keeping up with the paver.

## Vibratory Selection

Selecting the amplitude that provides the correct force and selecting the frequency that matches paving speed are critical to successful asphalt compaction. Cat asphalt compactors offer vibratory systems with dual amplitudes and frequencies. Vibratory versatility and the knowledge to use it are fundamental and part of the Caterpillar solution.

## Keeping the Drum Surface Wet

Keeping the drum wet is critical to all asphalt compactors. The high capacity water spray system offers triple filtration and optimum flow for excellent performance.

## Power and Efficiency

Having enough power to perform on inclines and maintaining the desired impact spacing when changing directions is essential to asphalt compaction. The Cat 3054C DIT engine combines the power to excel in tough conditions with the fuel efficiency to continue operating throughout the day.

## Matching Paving Speed

Keeping pace with the paver ensures that compaction takes place in the desired temperature zone. Choosing the right drum width that effectively covers the mat, while matching the vibratory frequency with the speed of the paver, leads to consistent mat quality.



# Vibratory System

Effective performance on a variety of applications.

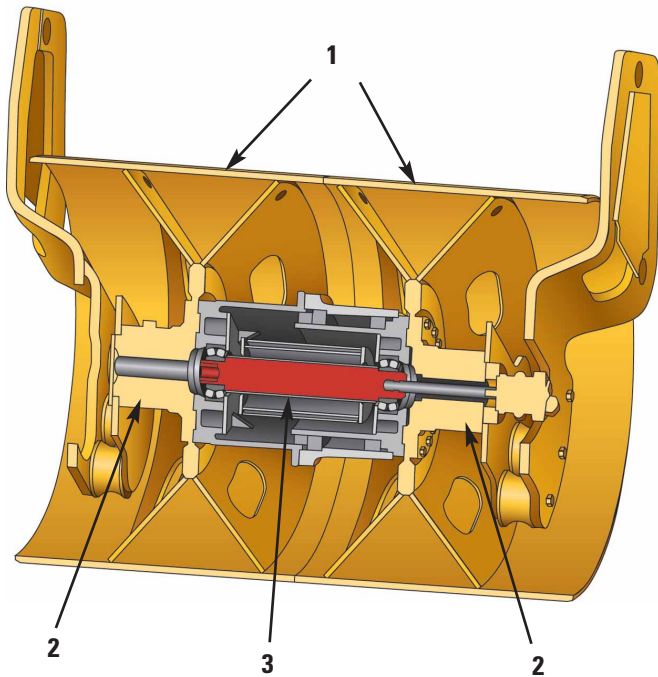

## Exclusive Pod Design

The exclusive axle-type pod design utilizes tapered roller bearings that support each drum half and eliminates any potential for contact between the two halves. Dual seals provide two layers of protection that prevent contamination and ensure long-term performance. Oil bath lubrication delivers continuous recirculation of oil inside the sealed housing, leading to longer service intervals and lower overall operating costs.

## Dual Amplitude/Dual Frequency

Dual amplitude settings work efficiently in a wider range of applications. A switch at the operator station changes amplitude and its corresponding frequency. This simple setup eliminates the guess-work associated with vibratory selection.

## Automated Vibratory Control

An auto-vibe function allows the operator to determine when the vibratory system should engage upon starting out or when changing direction. Automatic vibration start-up and shut-off helps produce smooth, high quality mats. This function also has a manual control for start-and-stop work.

## 1 Split Drum

## 2 Propel Hydraulic Motor

## 3 Vibratory System

# Water Spray System

The Cat spray system provides redundancy that ensures reliable performance and keeps the machine on the mat.

## Hours of Operation

The single, 750 L (198 gal) water tank provides hours of operation between refills. Spray can be set on continuous for maximum wetting action or intermittent for maximum duration between fill-ups. The sloping design provides excellent machine visibility to the drum while the single fill point can be accessed from the left side of the machine.

## Excellent Filtration

Keeping the spray nozzles free of foreign particles is essential to asphalt compaction. The Cat system provides triple filtration that minimizes clogs. The filters are highly accessible and can be quickly removed for cleaning without the use of special tools, limiting machine downtime.

## Long-Life Pumps

Dual water pumps provide the necessary flow to the spray nozzles. During operation the pump usage alternates with the direction of travel so that only one pump operates at a time. Alternating pump usage extends the operational life, while lowering replacement costs.



# Split Drums

Superior mat finish with Caterpillar exclusive split drums.



## Tight Turning Without Tearing

The exclusive split drum propel system provides a tight turning radius without damaging the hot mat. When turning, the outside drum half rotates faster than the inside drum, eliminating the potential for shoving that occurs on standard vibratory drum designs.

## Wide Drum Offset

The 1.3 m (51") drum offset provides more coverage for higher production on thin mats while minimizing heat loss prior to compaction. Ease of operation is provided through fingertip control at the propel lever, enabling one-handed operation. An audio alarm alerts the operator when the drums are aligned, allowing the operator to concentrate on mat conditions.

## Heavy-duty Design

Thick steel fabrication provides a strong, solid frame that resists flexing and holds up to the tough operating conditions of asphalt compaction. This heavy-duty design optimizes vibratory efficiency by directing vibration into the mat, not through the machine frame as wasted energy.

The frame features a unique center beam that provides easy access to the engine and other main components. The robust front and rear hitch designs include maintenance-free roller bearings that are sealed and greased for life, leading to reduced service requirements and lower life-time operating costs.

## Steering

Wide offset capability provides high production work.

### Four Steering Modes

The CD54 features four steering modes: front, rear, coordinated front and rear, and crab operation. When fully offset, coordinated steering produces a 2.8 m (110") inside turning radius for maximum job site maneuverability.

### Sensitive To The Touch Steering

The benefit of electronic steering is combined with the feel of hydraulic steering. When the drum encounters resistance, friction to the steering wheel increases, providing an intuitive feel that is extremely beneficial when operating adjacent to vertical barriers and curbs or when drum articulation reaches the end of travel during tight turns.

**1 Front Steering**

**2 Rear Steering**

**3 Coordinated Steering**

**4 Crab Operation (when in the maximum drum offset position the front drum still has a  $\pm 5\%$  steering angle).**

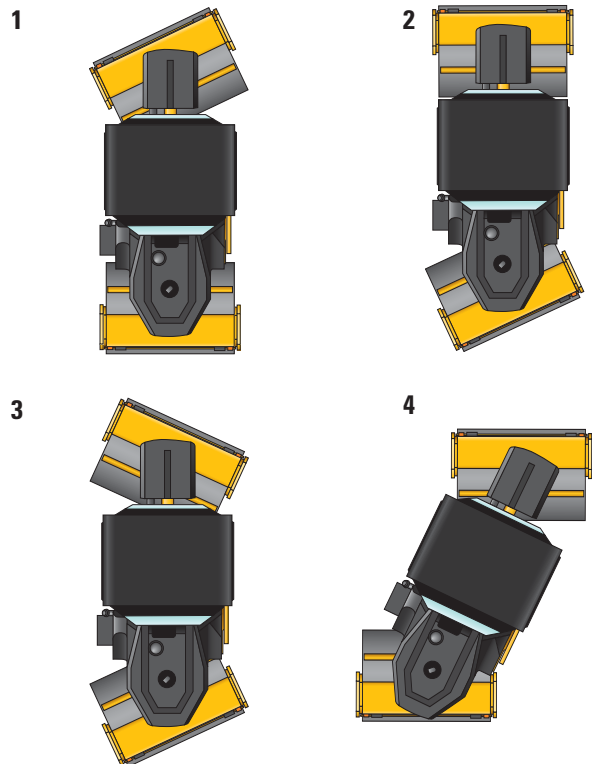



# Powertrain

Smooth control and quiet operation leads to higher productivity.

## Cat Engine

The 4-cylinder Cat 3054C Direct Injection Turbo (DIT) engine provides clean, quiet operation while delivering superior performance and durability. The 74.5 kW (99.5 hp) rated gross power engine meets U.S. EPA Tier 2 engine emission requirements.

## Balanced Torque and Proportional Speed Control

The split-drum drive system features an electronically actuated traction control feature that prevents unequal rotation of the drum halves and assures balanced torque when traveling straight. In order to avoid tearing the mat in tight turns, the drum halves rotate at different speeds. The system features speed sensing propel motors that allow additional flow to the outside drum drive, ensuring proportional speed between the drum halves. The proportional speed is controlled by the steering angle and the ECM controller to ensure balanced torque when turning. The split-drum drive system utilizes maintenance-free tapered roller bearings, for excellent reliability.

- 1 Four hydraulic motors with integrated parking brakes
- 2 Hydraulic flow divider valves providing balanced flow to front and rear motors

## Smooth Operation

Responsive controls generate operator confidence and improve productivity. When in control, operators are able to stay focused on mat conditions, allowing them to make the necessary adjustments throughout the day. To accomplish this, the machine uses an electronic control module (ECM) that monitors the propel system for optimal performance.

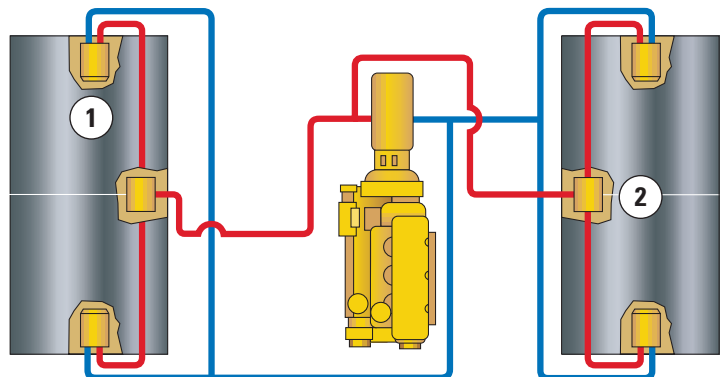

# Operating Environment

Superior comfort keeps you productive all day long.

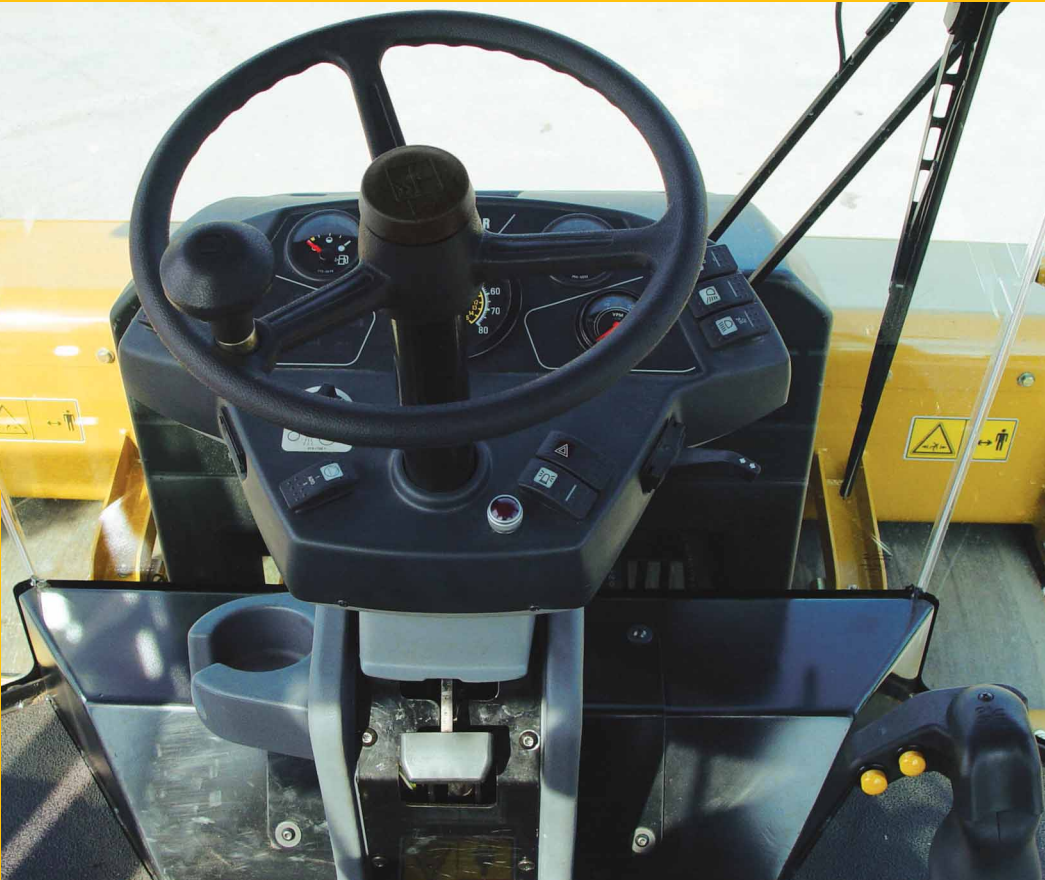

## All-Around Visibility

Keeping operators alert of their surroundings and aware of the machine and mat conditions is a focus of the operating station. The ROPS/FOPS cab with full floor-to-ceiling glass on the front and rear corners provides an unobstructed line of sight to the drum edges, drum surfaces, and both sides of the machine. The right hand window can be easily opened for additional side visibility when required. Good all-around visibility enables the operator to optimize water spray performance and compaction coverage when operating in the offset steering mode.

## Comfortable Seating

Keeping the job site in clear view is important when working close to the paver. The multi-position seating provides a variety of adjustments that help the operator stay focused and in control. A tilting steering column and multiple seat adjustments allow the operator to customize weight, height, armrests, and the backrest to suit their individual needs.

## Automatic Speed Control (ASC)

A speed control dial used in conjunction with the propel lever provides a cruise control type feature that allows the operator to meet the required speed to keep pace with the paver. By moving the propel lever to full forward or to full reverse allows the machine to travel at the speed determined by the adjustable dial.

## Convenient Controls

At Caterpillar, we strive to build machines that accommodate operators with all types of skill level. We understand that providing machines that perform well regardless of skill level can lead to greater productivity. Convenient layout and easy-to-understand controls build operator confidence. Being able to locate controls and understand their function allows operators to work more effectively, leading to better performance and higher productivity.

# Serviceability

Easy access and minimal maintenance requirements keep your machine on the job.



## Quick Resolution

The electronic control modules (ECM) on the new asphalt compactors are compatible with Cat Electronic Technician, making diagnostic efforts quick and easy. The machine is equipped with ECMs for the propel and vibratory systems, providing quick resolution to any issues that may arise.

## Accessibility is Fundamental

Having quick access to components and routine service points is fundamental to Cat equipment. The hydraulic system contains grouped pressure test ports and oil sampling ports — no need to break into the circuit and risk contamination. The filters for engine oil, hydraulic oil, fuel, and air are all easily accessible, while the drain ports utilize remote lines that simplify collection.

## Longer Service Intervals Save Money

Extended service intervals have a positive impact on the bottom line by maximizing uptime and minimizing oil and filter replacement costs. The standard 500 hour engine oil change interval keeps costs low.

## Minimal Service Required

Features such as tapered roller bearings in the split drum and the maintenance-free hitch design with sealed for life articulation joints continue to provide unmatched reliability and limit service requirements.

## Customer Support

Your Cat dealer is ready to assist you with your purchase decision and everything after.

- Make comparisons of machines with estimates of component life, preventative maintenance and cost of production.
- Financing packages are flexible to meet your needs.
- Your Cat dealer can evaluate the cost to repair, rebuild and replace your machine in order to help you make the right choice.
- For more information on Cat products, dealer services and industry solutions, visit us at [www.cat.com](http://www.cat.com).





# CD54 Vibratory Asphalt Compactor Specifications

## Engine

Model: Cat 3054C DIT, 4 cylinder liquid cooled engine rated at 2200 rpm

### Gross Power

ISO 14396	74.5 kW / 99.5 hp
-----------	-------------------

SAEJ1995	74.5 kW / 99.5 hp
----------	-------------------

### Net Power

ISO 9249	72 kW / 98 hp
----------	---------------

80/1269/EEC	72 kW / 98 hp
-------------	---------------

Bore	105 mm (4.13")
------	----------------

Stroke	127 mm ( 5.0")
--------	----------------

Displacement	4.4 L (269 in <sup>3</sup> )
--------------	------------------------------

- Net Power ratings are tested at the reference conditions for the specified standard.
- Net power shown is the power available at the flywheel when the engine is equipped with alternator, air cleaner, muffler and fan at minimum speed.
- No derating required up to an altitude of 3000 m (9843 ft). Auto-derate protects hydraulic and transmission systems.
- The Cat 3054C DIT engine meets Stage II off-highway emission regulations.

## ROPS/FOPS

- Cat cab with integrated Rollover Protective Structure (ROPS/FOPS) is standard.
- ROPS meets ISO 3471:1994.
- FOPS meets ISO 3449:1992 Level II.

## Instrumentation

The instrument panel is located in front of the operator and contains the speedometer, vibrate tachometer, vibration mode selector, water spray system controls, light switches, hour meter, alternator indicator light, fuel gauge, warning lights and horn. An audible alarm sounds and warning light illuminates if abnormal conditions occur in engine oil pressure, engine coolant temperature or charge pressure. Operational lights are also positioned on the instrument panel. They illuminate if the vibratory system, drum spray system, neutral or parking brake are engaged.

Machine controls are also located to the operator's right on the control console. These controls include the start switch with cold-start aid, electric throttle, propel lever, speed selector switch, automatic speed control (ASC) dial, drum steering selector switch, horn and secondary/parking brake switch. Drum spray switch and vibration switch are on propel handle. Offset steering controlled by thumb switch located on propel handle for simple operation.

## Transmission

Variable displacement piston pump supplies pressure flow to single speed hydraulic motors driving each of the four split-drums. A single propel lever located on the side console provides smooth hydrostatic control of the machine's infinitely variable speed in both forward and reverse.

The Automatic Speed Control (ASC) system is a hydraulic control device that allows precise operating speed to be preset and maintained without further adjustment. ASC system also makes machine starts and stops smoother.

Three propel modes can be selected from the operator console; work, roading and high.

## Steering

Electric over hydraulic with active steering feedback feature provides a unique operational sensitivity when at the end of stroke or when maneuvering close to vertical obstructions.

## Brakes

### Primary Brake Feature

Closed-loop hydrostatic drive system provides dynamic braking during operation.

### Secondary Brake Features

Spring-applied/hydraulically released brake on front and rear drums. Actuated by a switch on console or automatically when pressure is lost in brake circuit or when engine is shut off or in the event of a major fault detection by the machine ECM. A manual release pump is included.

# CD54 Vibratory Asphalt Compactor Specifications

## Drum Spray System

Entire drum spray system is corrosion resistant and includes a large water tank with a single fill port and drain valve.

Self-adjusting spring-loaded scrapers located on the front of each split drum and two scrapers fitted behind the split drums prevent material build-up and keep the drums clean. The heavy-duty springs and molded polyurethane design maintain consistent pressure across the entire drum width in order to maximize scraper wear.

Spray can be set on continuous for maximum wetting action or intermittent for maximum duration between fill-ups. The "Auto" selection pulls water from one pump traveling forward and from the other pump while traveling rearward. The water spray system automatically shuts off when the machine is in neutral.

## Service Refill Capacities

Fuel tank	160 L	42.3 gal
Water Spray Tank	750 L	198 gal
Cooling system	28 L	7.4 gal
Engine oil w/filter	9 L	2.4 gal
Hydraulic system (including hoses)	82 L	21.6 gal
Hydraulic tank	49 L	12.9 gal
Vibratory bearing lubrication (per drum)	8 L	2.1 gal

## Standard Equipment

- Front and Rear Split-drum
- Dual Amplitude and Dual Frequency Vibratory System
- Sealed Pod Style Vibratory System
- Drum Offset, 1300 mm (51")
- ROPS/FOPS Cab
- Two-speed Hydrostatic Transmission
- Automatic Traction Control
- Locking Engine Compartment and Cab
- Vandalism Guard on Lights
- Triple Filtered Water System
- 750 L (198 gal) Water Capacity
- 12V Electrical System
- 80 A Alternator

## Optional Equipment

- Air Conditioning
- Bio-Degradable Oil
- Freeze Protection Kit (Water Supply)
- Mirrors
- Sun Canopy
- Warning Beacon
- Water Distribution Mats (Cocoa)
- Water Distribution Mats (Rubber)
- Product Link
- Recording Module
- Edge Cutter
- Chip Spreader Ready
- Weight Kit

# CD54 Asphalt Vibratory Compactor Specifications

## Dimensions and Weights

Dimensions and weights are approximate.

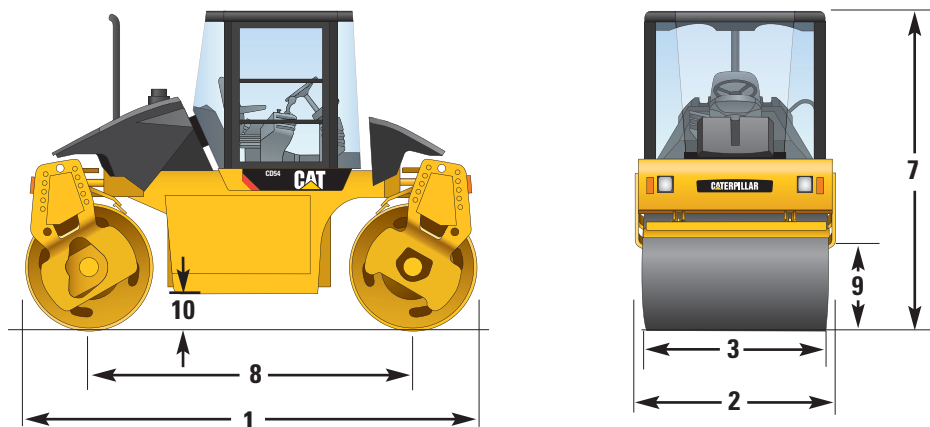

<b>1</b>	Overall length	4270 mm	168 in
<b>2</b>	Overall width	1873 mm	74 in
<b>3</b>	Drum width	1700 mm	67 in
	Drum offset	1300 mm	51 in
	Drum shell thickness	17 mm	0.67 in
	Drum diameter	1200 mm	47 in
<b>7</b>	Overall height at ROPS/FOPS	3042 mm	120 in
<b>8</b>	Wheelbase	3070 mm	121 in
<b>9</b>	Curb clearance	777 mm	30.5 in
<b>10</b>	Ground clearance	372 mm	14.5 in

## Operating Weights

Standard machine w/ROPS/FOPS Cab	9500 kg	20,944 lb
Maximum machine	10 900 kg	24,030 lb
Weight at front drum	4655 kg	10,263 lb
Weight at Rear drum	4845 kg	10,681 lb
Static linear load	28 kg/cm	153 lb/in
Maximum static linear load	32 kg/cm	159 lb/in

Standard operating weights include lubricants, coolant, 80 kg (175 lb) operator, full fuel tank, full hydraulic system and 1/2 full water tank.  
Maximum machine weight includes all attachments, full fluids and an 80 kg (175 lb) operator.

## Vibratory System

Frequency	53/42 Hz	3180/2520 vpm
Amplitude — High	0.62 mm	0.024 in
Low	0.34 mm	0.013 in
Centrifugal Force — High	84 kN	18,900 lb
Low	74.5 kN	16,762 lb

## Miscellaneous

Steering (inside drum edge)	2800 mm	110 in
(outside drum edge)	4500 mm	177 in
Speed: (low)	0 - 7 km/hr	0 - 4.5 mph
(high)	0 - 9 km/hr	0 - 5.5 mph
Articulation Angle		25°
Oscillation Angle		±8°

# CD54 Vibratory Asphalt Compactor

For more complete information on Cat products, dealer services, and industry solutions, visit us on the web at [www.cat.com](http://www.cat.com)

QEHQ1382 (8/09)

© 2009 Caterpillar  
All Rights Reserved  
Printed in U.S.A.

Materials and specifications are subject to change without notice. Featured machines in photos may include additional equipment. See your Cat dealer for available options.

CAT, CATERPILLAR, ACERT, their respective logos, and "Caterpillar Yellow," as well as corporate and product identity used herein, are trademarks of Caterpillar and may not be used without permission.

