

# 216B/226B/236B Series 3 242B/252B Series 3

## Skid Steer Loaders



	216B Series 3	226B Series 3	236B Series 3	242B Series 3	252B Series 3
<b>Engine</b>					
Engine Model	Cat C2.2	Cat C2.2 T	Cat C3.4 DIT	Cat C3.4 DIT	Cat C3.4 DIT
Net Power (SAE 1349/ISO 9249)	35 kW (47 hp)	42 kW (56 hp)	53 kW (71 hp)	53 kW (71 hp)	53 kW (71 hp)
<b>Weights</b>					
Operating Weight	2581 kg (5,690 lb)	2641 kg (5,822 lb)	3178 kg (7,007 lb)	3179 kg (7,008 lb)	3565 kg (7,861 lb)
<b>Operating Specifications</b>					
Rated Operating Capacity	635 kg (1,400 lb)	680 kg (1,500 lb)	884 kg (1,950 lb)	975 kg (2,150 lb)	1202 kg (2,650 lb)



## Features

### Comfortable Operator Station

*Spacious, comfortable cab and ergonomic, low effort joystick controls reduce operator fatigue.*

### High Performance Power Train

*High horsepower and torque deliver outstanding performance.*

### Advanced Hydraulic System

*Hydraulic system provides maximum power and reliability for demanding applications.*

### More Work Tools

*Caterpillar's broad range of performance matched work tools make the Cat Skid Steer Loader the most versatile machine on the job site.*



## Contents

Operator Station.....	3
Hydraulics .....	4
Power Train.....	5
Lift Linkages .....	5
Work Tools.....	6
Serviceability.....	7
Customer Support.....	7
Specifications.....	8
Standard Equipment.....	12
Optional Equipment.....	13
Notes.....	14

**The Cat B-Series 3 Skid Steer Loader, with its many work tool options, delivers outstanding performance to help you get more done and increase your bottom line. Spacious, ergonomic operator station and easy-to-use pilot operated joystick controls keep you comfortable throughout the work day. High performance power train, advanced hydraulic system and traditional Cat reliability improve your productivity in the toughest working conditions.**



# Operator Station

Superior comfort to keep you productive throughout the work day.

## All Day Comfort

Comfort and ease of operation have been designed into every aspect of the operator station. The wide, spacious interior and uncluttered floor provide a comfortable work environment with excellent head, shoulder and leg room to keep productivity high and fatigue low. The adjustable seat and low effort controls keep the operator comfortable throughout the work day.

## Low Effort Joystick Controls

Ergonomic, pilot hydraulic controls deliver precise control with minimal effort. The right joystick controls the loader raise, lower and tilt functions while the left joystick controls the forward and reverse travel speed plus direction. Optional deluxe joysticks provide additional auxiliary controls with fingertip control of many work tool functions, including proportional work tool hydraulics and work tool electrical. Basic and deluxe joystick functions include one-touch continuous auxiliary hydraulic flow and momentary auxiliary hydraulic flow.

## Excellent Visibility

The wide cab opening offers an exceptional view to the work tool. The sloped angle of the engine compartment allows excellent visibility to the rear of the machine. The standard rear view mirror gives the operator a panoramic view of the machine's rear and sides. The side windows remove easily for cleaning.

## Additional Features for Maximum Comfort

The B-Series 3 machines offer the following additional features to help you on the job:

- Suspension seat option for even greater operator comfort.
- Easy to read instrument panels.
- Optional air conditioner and heater for greater comfort in extreme conditions.
- Standard floor mat with footrest provides non-slip surface and can be removed for easy cleaning.
- Ergonomic, contoured and padded armbar provides comfortable operation.





# Hydraulics

Exceptional lift, breakout and power to meet your needs.

## High Performance Hydraulic System

Maximum power and reliability are built into the machine's hydraulic system. In addition to providing power to the wheels, this system also provides the loader lift and tilt functions, powers the auxiliary circuit to drive work tools and drives the engine cooling fan. The hydraulic pumps are driven directly off the engine for maximum hydraulic performance and reliability – no belts are used. The hydraulic system also features:

- Standard auxiliary hydraulics to power work tools that are available through quick connect hydraulic couplings rigidly mounted to the loader arm.
- Cat ToughGuard™ hoses for increased reliability and durability.

## High Flow Hydraulics

High flow hydraulic system is available on the 226B Series 3 and 242B Series 3 for greater machine versatility and increased work tool performance.

## High Efficiency Cooling System

Cooling capacity is maximized through the use of a side-by-side cooling package and hydraulically driven cooling fan.

- High-efficiency, hydraulic oil cooler lets the machine work longer and harder in higher ambient temperatures, even with continuous work tool usage.
- Efficient, hydraulically driven cooling fan provides cooling even when the machine is under load.
- Optional variable speed demand fan provides improved fuel efficiency, increased machine performance, reduced sound levels and improved cold weather performance.



# Power Train

Aggressive performance with fuel efficiency.

## Cat Engine

The high performance power train provides high engine horsepower and torque. The B-Series 3 machines feature rugged, reliable Cat engines that meet U.S. EPA Tier 4 Interim and EU Stage IIIA emissions requirements.

## Hand and Foot Throttles

Hand and foot throttles allow the operator to match engine speed to the task. The hand throttle is ideal for jobs requiring constant engine speed such as cold planing, trenching or snow blowing. The foot throttle lets the operator vary engine speed and minimize fuel consumption for other tasks such as load and carry, truck loading, grading and dozing.

## Anti-Stall Feature

The anti-stall system maximizes machine power at all times by matching the engine torque with the operational requirements of the hystat and implement systems. This load sensing feature prevents the engine from stalling even during part throttle operation, keeping productivity high and fuel consumption low.

## Two Speed Option

Two speed is available as an option on the 236B Series 3, 242B Series 3 and 252B Series 3 Skid Steer Loader to improve cycle times and get the job done faster.



# Lift Linkages

Built for tough jobs.

## Choice of Lift Designs

Two types of lifting arrangements are available – vertical lift (path #1 above) and radial lift (path #2) – to meet your specific application needs.

### Vertical Lift

The 242B Series 3 and 252B Series 3 feature the vertical lift design which provides extended reach and lift height for quick and easy truck loading and material placement. The lift height is 3086 mm (121 in) on the 242B Series 3 and 3210 mm (126 in) on the 252B Series 3.

### Radial Lift

The 216B Series 3, 226B Series 3 and 236B Series 3, with their radial lift design, deliver excellent digging performance with superior mid-lift reach.



# Work Tools

Do more jobs with one machine with Cat Work Tools.



## The Right Tool for the Job

Get the most out of your machine with the comprehensive line of Cat Work Tools. Designed and built for optimum performance and durability, these tools deliver high productivity in a variety of applications to maximize the versatility and flexibility of the Cat Skid Steer Loader:

- Augers
- Backhoes
- Blades (angle, dozer)
- Buckets (general purpose, high capacity, dirt, utility, light material, multi purpose, industrial grapple, utility grapple)
- Brooms (angle, pickup, utility)
- Brushcutters
- Cold Planers
- Forks (pallet, industrial grapple, utility grapple, utility)
- Hydraulic Hammers
- Landscape Tillers
- Landscape Rakes
- Material Handling Arm
- Power Box Rakes
- Shear
- Snow Blowers
- Stump Grinders
- Trenchers
- Vibratory Compactors
- Wheel Saws

## Quick Couplers

Work tools can be changed quickly and easily with the machine's quick coupler system. The standard quick coupler features manual engagement and disengagement of work tools using two high leverage handles. The optional hydraulic quick coupler allows the operator to quickly change tools without leaving the cab.



# Serviceability

Simplified service and maintenance save you time and money.



## Easy Service

Convenient service features make maintenance easy, reducing your downtime:

- Industry exclusive tilt-up cooling package provides superior access to service points and coolers.
- Rear door opens 90 degrees for easy access to both sides of the engine.
- Cab tilts rearward for easy access to all hydraulic pumps, motors, valves, lines and hydraulic tank.
- Daily maintenance points are easily accessible.
- Electrical wiring is color coded and numbered for easy identification.
- S-O-S<sup>SM</sup> oil sampling valve is standard to allow regular monitoring of the hydraulic oil quality.

## Customer Support

Support you can count on.

### Superior Dealer Services

Your Cat dealer is ready to assist you with your purchase decision and everything after.

- Make comparisons of machines, with estimates of component life, preventative maintenance and cost of production.
- Financing packages are flexible to meet your needs.
- Your Cat dealer can evaluate the cost to repair, rebuild and replace your machine, so you can make the right decision.
- For more information on Cat products, dealer services and industry solutions, visit us at [www.cat.com](http://www.cat.com).



# B-Series 3 Skid Steer Loaders Specifications

## Engine

Engine Model		
216B Series 3	Cat C2.2	
226B Series 3	Cat C2.2 T	
236B/242B/252B Series 3	Cat C3.4 DIT	
Net Power (SAE 1340/ISO 9249)		
216B Series 3	35 kW	47 hp
226B Series 3	42 kW	56 hp
236B/242B/252B Series 3	53 kW	71 hp
Gross Power (SAE J1995)		
216B Series 3	38 kW	51 hp
226B Series 3	45.5 kW	61 hp
236B/242B/252B Series 3	55 kW	74 hp
Displacement		
216B/226B Series 3	2.2 L	134 in <sup>3</sup>
236B/242B/252B Series 3	3.3 L	201 in <sup>3</sup>
Stroke		
216B/226B Series 3	100 mm	3.9 in
236B/242B/252B Series 3	120 mm	4.7 in
Bore		
216B/226B Series 3	84 mm	3.3 in
236B/242B/252B Series 3	94 mm	3.7 in

## Weights\*

Operating Weight		
216B Series 3	2581 kg	5,690 lb
226B Series 3	2641 kg	5,822 lb
236B Series 3	3178 kg	7,007 lb
242B Series 3	3179 kg	7,008 lb
252B Series 3	3565 kg	7,861 lb

## Operating Specifications\*

Rated Operating Capacity		
216B Series 3	635 kg	1,400 lb
226B Series 3	680 kg	1,500 lb
236B Series 3	884 kg	1,950 lb
242B Series 3	975 kg	2,150 lb
252B Series 3	1202 kg	2,650 lb
Rated Operating Capacity with Optional Counterweight		
216B Series 3	680 kg	1,500 lb
226B Series 3	726 kg	1,600 lb
236B Series 3	929 kg	2,050 lb
242B Series 3	1000 kg	2,200 lb
252B Series 3	1225 kg	2,700 lb
Tipping Load		
216B Series 3	1270 kg	2,800 lb
226B Series 3	1360 kg	3,000 lb
236B Series 3	1769 kg	3,900 lb
242B Series 3	1950 kg	4,300 lb
252B Series 3	2404 kg	5,300 lb
Breakout Force, Tilt Cylinder		
216B/226B Series 3	1852 kg	4,083 lb
236B Series 3	2487 kg	5,484 lb
242B Series 3	2044 kg	4,507 lb
252B Series 3	2498 kg	5,508 lb

\* Operating Weight, Operating Specifications and Dimensions all based on 75 kg (165 lb) operator, all fluids, 1 speed, OROPS, dirt bucket, tires, no optional counterweights and manual quick coupler (unless otherwise noted).

## Hydraulic System

Hydraulic Flow	Standard	
Loader Hydraulic Pressure	23 000 kPa	3,335 psi
Loader Hydraulic Flow – 216B/226B Series 3	61 L/min	16 gal/min
Loader Hydraulic Flow – 236B/242B/252B Series 3	83 L/min	22 gal/min
Hydraulic Power (calculated) – 216B/226B Series 3	23.2 kW	31.1 hp
Hydraulic Power (calculated) – 236B/242B/252B Series 3	31.9 kW	42.8 hp
Hydraulic Flow	High Flow – 226B Series 3	
Loader Hydraulic Pressure	23 000 kPa	3,335 psi
Loader Hydraulic Flow	104 L/min	27 gal/min
Hydraulic Power (calculated)	37.7 kW	50.6 hp
Hydraulic Flow	High Flow – 242B Series 3	
Loader Hydraulic Pressure	23 000 kPa	3,335 psi
Loader Hydraulic Flow	117 L/min	31 gal/min
Hydraulic Power (calculated)	45 kW	60.3 hp

Model availability may vary by region.



<b>Cab</b>	
ROPS	SAE J1040 MAY94, ISO 3471:1994
FOPS	SAE J/ISO 3449 APR98 Level I, ISO 3449:1992 Level I
FOPS Level II	SAE J/ISO 3449 APR98 Level II, ISO 3449:1992 Level II (optional)

<b>Power Train</b>		
Travel Speed (Forward or Reverse)		
216B/226B Series 3	12.7 km/h	7.9 mph
236B Series 3	12.1 km/h	7.5 mph
242B Series 3	12.4 km/h	7.7 mph
252B Series 3	11.9 km/h	7.4 mph
Travel Speed (Forward or Reverse) – 2 Speed Option		
236B Series 3	18.1 km/h	11.2 mph
242B Series 3	18.4 km/h	11.4 mph
252B Series 3	17.8 km/h	11.1 mph

<b>Service Refill Capacities</b>		
Chain Box, each side		
216B/226B/242B Series 3	6 L	1.6 gal
236B Series 3	7 L	1.8 gal
252B Series 3	8 L	2.1 gal
Cooling System	10 L	2.6 gal
Engine Crankcase		
216B/226B Series 3	10 L	2.6 gal
236B/242B/252B Series 3	9 L	2.4 gal
Fuel Tank		
216B/226B/242B Series 3	58 L	15.4 gal
236B/252B Series 3	90 L	23.8 gal
Hydraulic System		
216B/226B/242B Series 3	55 L	14.5 gal
236B Series 3	52 L	13.7 gal
252B Series 3	53 L	14 gal
Hydraulic Tank	35 L	9.2 gal

# B-Series 3 Skid Steer Loaders Specifications

## Dimensions

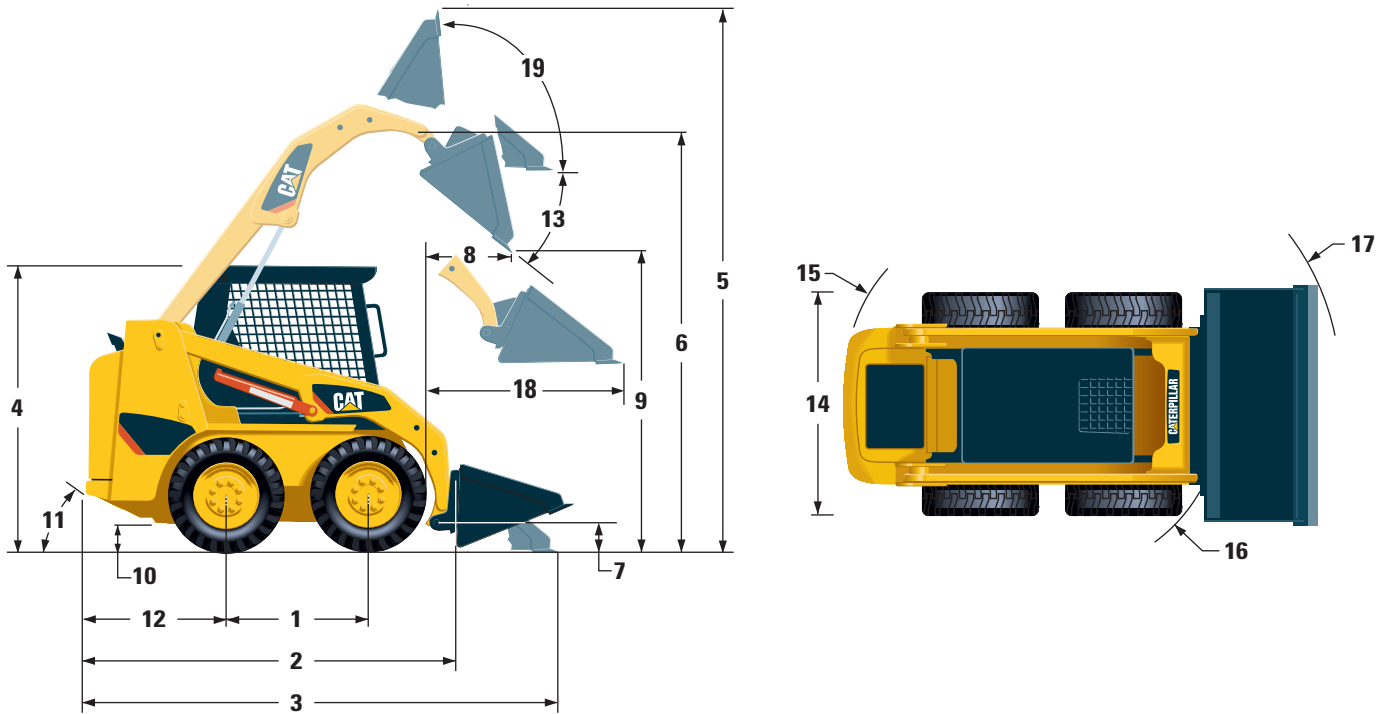

	216B/226B Series 3		236B Series 3	
	mm	in	mm	in
1 Wheelbase	986	39	1134	45
2 Length without Bucket	2519	99	2800	110
3 Length with Bucket on Ground	3233	127	3515	138
4 Height to Top of Cab	1950	77	2092	82
5 Maximum Overall Height	3709	146	3965	156
6 Bucket Pin Height at Maximum Lift	2854	112	3099	122
7 Bucket Pin Height at Carry Position	200	8	215	8.4
8 Reach at Maximum Lift and Dump	505	20	541	21
9 Clearance at Maximum Lift and Dump	2169	85.4	2398	94
10 Ground Clearance	195	8	235	9.3
11 Departure Angle	26°		28°	
12 Bumper Overhang Behind Rear Axle	967	38	1038	41
13 Maximum Dump Angle	40°		40°	
14 Vehicle Width over Tires	1525	60	1676	66
15 Turning Radius from Center – Machine Rear	1502	59	1623	64
16 Turning Radius from Center – Coupler	1195	47	1318	52
17 Turning Radius from Center – Bucket	1944	77	2092	82
18 Maximum Reach with Arms Parallel to Ground	1291	51	1353	53
19 Rack Back Angle at Maximum Height	81°		83°	



## Dimensions

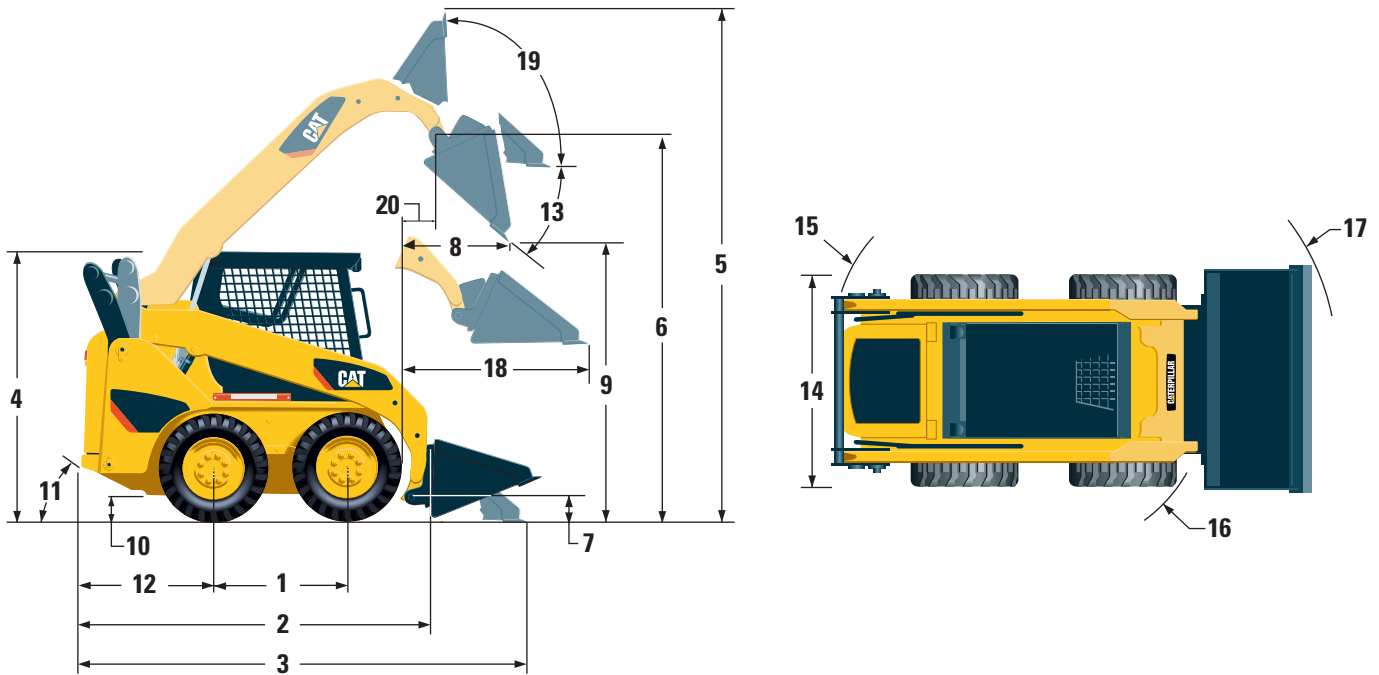

	242B Series 3		252B Series 3	
	mm	in	mm	in
<b>1</b> Wheelbase	1094	43.1	1228	48
<b>2</b> Length without Bucket	2760	108.7	2901	114
<b>3</b> Length with Bucket on Ground	3437	135.3	3616	142
<b>4</b> Height to Top of Cab	2019	79	2063	82.6
<b>5</b> Maximum Overall Height	3918	154	4062	160
<b>6</b> Bucket Pin Height at Maximum Lift	3086	121	3210	126
<b>7</b> Bucket Pin Height at Carry Position	228	9	213	8.4
<b>8</b> Reach at Maximum Lift and Dump	622	24	829	33
<b>9</b> Clearance at Maximum Lift and Dump	2333	92	2421	95
<b>10</b> Ground Clearance	178	7	196	7.7
<b>11</b> Departure Angle	28°		26.4°	
<b>12</b> Bumper Overhang Behind Rear Axle	989	39	1043	41
<b>13</b> Maximum Dump Angle	50°		51°	
<b>14</b> Vehicle Width over Tires	1676	66	1829	72
<b>15</b> Turning Radius from Center – Machine Rear	1556	61	1679	66
<b>16</b> Turning Radius from Center – Coupler	1311	52	1362	54
<b>17</b> Turning Radius from Center – Bucket	2092	82	2167	85
<b>18</b> Maximum Reach with Arms Parallel to Ground	1216	48	1257	50
<b>19</b> Rack Back Angle at Maximum Height	88°		88°	
<b>20</b> Bucket Pin Reach at Maximum Lift	254	10	348	13.7

# B-Series 3 Skid Steer Loaders Standard Equipment

Standard equipment may vary. Consult your Cat dealer for details

## ELECTRICAL

12 volt Electrical System  
65 ampere Alternator (216B Series 3)  
85 ampere Alternator (226B Series 3)  
90 ampere Alternator  
(236B/242B/252B Series 3)  
Automatic Glow Plug Activation  
Heavy Duty Battery, 880 CCA  
(standard on the 236B/242B/252B Series 3)  
Ignition Key Start/Stop Switch  
Lights: Gauge backlighting, two rear tail  
lights, two adjustable front and rear halogen  
lights, dome light.

## OPERATOR ENVIRONMENT

Gauges: Fuel level, hour meter  
Operator Warning System Indicators:  
Air filter restriction, alternator output,  
armrest raised/operator out of seat,  
engine coolant temperature, engine oil  
pressure, glow plug activation, hydraulic  
filter restriction, hydraulic oil temperature,  
parking brake engaged  
Vinyl seat  
Pull Down Ergonomic Contoured Armrest  
Control Interlock System, when operator  
leaves seat or armrest raised: Hydraulic  
system disables, hydrostatic transmission  
disables, parking brake engages  
ROPS Cab, Open, Tilt Up  
FOPS, Level I  
Top and Rear Windows  
Floor Mat  
Interior Rear View Mirror  
12 volt Electric Socket  
Horn  
Backup Alarm  
Hand and Foot Throttle

## POWER TRAIN

Cat C2.2 Diesel Engine (216B Series 3)  
Cat C2.2 T Diesel Engine (226B Series 3)  
Cat C3.4 DIT Diesel Engine  
(236B/242B/252B Series 3)  
Engines are Tier 4 Interim/Stage IIIA  
Compliant  
Air Cleaner, Dual Element, Radial Seal  
S·O·S<sup>SM</sup> Sampling Valve, Hydraulic Oil  
Filters, Spin-on, Hydraulic  
Filters, Bayonet-type, Fuel  
and Water Separator  
Tilt Up Radiator/Hydraulic Oil Cooler  
Spring Applied, Hydraulically Released  
Parking Brakes  
Hydrostatic Transmission  
Four Wheel Chain Drive

## OTHER

Engine Enclosure, Lockable  
Extended Life Antifreeze, -36° C (-33° F)  
Machine Tie Down Points (4)  
Support, Lift Arm  
Hydraulic Oil Level Sight Gauge  
Radiator Coolant Level Sight Gauge  
Radiator, Expansion Bottle  
Cat ToughGuard™ Hose  
Auxiliary, Hydraulics, Continuous Flow  
Heavy Duty, Flat Faced Quick Disconnects  
Split D-Ring to Route Work Tool Hoses  
Along Side of Left Lift Arm  
Electrical Outlet, Beacon  
Belly Pan Cleanout

## MANDATORY EQUIPMENT

Quick Coupler, Mechanical or Hydraulic  
Seat Belt, 50 mm (2 in) or 75 mm (3 in)  
EU Preparation Package  
(Europe only – includes Demand Fan  
on the 226B/242B Series 3)  
Cooling Fan, Demand or Standard  
(EU Preparation Package includes Demand  
Fan on the 226B/242B Series 3)

## Comfort Packages

(must select one of the following):

- Open ROPS (C0): Static Seat
- Open ROPS (C1): Suspension Seat,  
Deluxe Headliner
- Enclosed ROPS (C2): Features of  
C1 Package plus Heater, Cab Door, Side  
Windows, Cup Holder, Cab Debris Barrier
- Enclosed ROPS (C3): Features of  
C2 Package plus Air Conditioner  
(not available on the 216B Series 3)

Control Packages for the 216B/226B Series 3  
(must select one of the following):

- Control Package 1: On/Off Auxiliary  
Hydraulics Basic
- Control Package 2: Proportional Auxiliary  
Hydraulics Deluxe
- Control Package 3: Proportional Auxiliary  
Hydraulics Deluxe, Work Tool Harness
- Control Package 4: High Flow Hydraulics  
(226B Series 3 only)

Control Packages for the 236B/242B/252B  
Series 3 (must select one of the following):

- Control Package 1: On/Off Auxiliary  
Hydraulics Basic
- Control Package 2: Proportional  
Auxiliary Hydraulics Deluxe, 1 Speed
- Control Package 3: Proportional  
Auxiliary Hydraulics Deluxe, 1 Speed,  
Work Tool Harness
- Control Package 4: Proportional  
Auxiliary Hydraulics Deluxe, 2 Speed
- Control Package 5: Proportional  
Auxiliary Hydraulics Deluxe, 2 Speed,  
Work Tool Harness
- Control Package 6: High Flow Hydraulics,  
1 Speed (242B Series 3 only)
- Control Package 7: High Flow Hydraulics,  
2 Speed (242B Series 3 only)



# B-Series 3 Skid Steer Loaders Optional Equipment

Optional equipment may vary. Consult your Cat dealer for details

Variable Speed Demand Fan  
(not available in all regions)  
Counterweight  
Beacon, Rotating

Engine Block Heater, 120V or 240V  
Heavy Duty Battery, 880 CCA  
(optional on the 216B/226B Series 3)  
Oil, Hydraulic, Cold Operation

Door, Glass or Polycarbonate  
Self-Leveling  
Paint, Custom







# B-Series 3 Skid Steer Loaders

For more complete information on Cat products, dealer services, and industry solutions, visit us on the web at [www.cat.com](http://www.cat.com)

© 2011 Caterpillar Inc.  
All rights reserved

Materials and specifications are subject to change without notice. Featured machines in photos may include additional equipment. See your Cat dealer for available options.

CAT, CATERPILLAR, SAFETY.CAT.COM, their respective logos, "Caterpillar Yellow" and the "Power Edge" trade dress, as well as corporate and product identity used herein, are trademarks of Caterpillar and may not be used without permission.

AEHQ6131-02 (06-2011)  
Replaces AEHQ6131-01

